

Epistemology of Environmental Microbiology

EUGENE L. MADSEN

Section of Microbiology Division of Biological Sciences Cornell University,
Ithaca, New York 14853-8101

Despite critical geochemical roles of microorganisms in biosphere maintenance, knowledge of microorganisms as they function in soils, sediments, and waters is limited. Constraints on knowledge are caused largely by methodologies that do not contend well with the complexity of field sites, with the scale differential between microorganisms and humans, and with artifacts that may arise in characterizing microorganisms using laboratory-based physiological, biochemical, genetic, and molecular biological assays. A paradigm describing how knowledge is obtained in environmental microbiology suggests that the constraints on knowledge will yield to relationships developing between methodological innovations and their iterative application to naturally occurring microorganisms in field sites.

Introduction

Since its early foundation in the work of Beijerinck and Winogradsky (1–3), environmental microbiology has been concerned with the presence, abundance, interactions, and physiological activities of microorganisms in terrestrial and aquatic environments. [Note: *The term microbiology has traditionally included five groups of microscopically visualizable organisms: bacteria, viruses, fungi, protozoa, and algae* (4). *Based on phylogenetic analysis of the ribosomal RNA molecule* (5–8), *the first of these five groups corresponds to the domains Archaea plus Bacteria, and the latter three groups are distributed throughout various branches of the Eukarya* (8, 9). *The physiological, morphological, ecological, and phylogenetic span of these organisms is immense and resists most generalizations. Consequently, this paper will address primarily a major subset of the microbial world, heterotrophic microorganisms—especially bacteria, but also fungi and protozoa. Because algae and some types of bacteria and protozoa are photosynthetic, specific comments related to nutrition may not always apply to these organisms. Some comments also may not apply to viruses because of their unique noncellular and parasitic traits.*] Environmental microbiology is related to, but distinct from, medical (10) and industrial (11) microbiology. One reason for advancing environmental microbiology is that a mechanistic understanding of microorganisms and their activities improves human ability to manage natural systems and expands biotechnological products and services (12, 13) essential for industrial and medical microbiology.

The earth's habitats present complex gradients of environmental conditions that include extreme variations in temperature, light, pH, pressure, salinity, and both inorganic and organic compounds (materials ranging from elemental sulfur to ammonia, hydrogen gas, and methane and from

carbohydrates to fats, proteins, lipids, nucleic acids, and humic substances). Each geochemical setting (e.g., anaerobic peatlands, oceanic hydrothermal vents, the surfaces of soil humus, deep subsurface sediments) determines the instability of resources that can be physiologically exploited by microorganisms. The thermodynamically governed interactions between these resources, their settings, microorganisms themselves, and 3.5 billion years of evolution are probably the source of metabolic diversity (14–18) of the microbial world (Figure 1). Microorganisms are the primary agents of geochemical change. The small size, ubiquitous distribution, high specific surface area, potentially high rate of metabolic activity, physiological responsiveness, genetic malleability, potentially rapid growth rate, and unrivaled enzymatic and nutritional diversity cast microorganisms in the role of recycling agents for the biosphere (5, 19, 20). Enzymes, classified in six major groups (21), accelerate reaction rates between thermodynamically unstable substances. Perhaps the most ecologically important class of enzymes catalyzes oxidation/reduction reactions that allow the microorganisms to generate metabolic energy, survive, and grow. Microorganisms procreate by carrying out complex, genetically regulated sequences of biosynthetic and assimilative intracellular processes. Each daughter cell has essentially the same macromolecular and elemental composition as its parent. Thus, integrated metabolism of all nutrients (e.g., carbon, nitrogen, phosphorus, sulfur, oxygen, hydrogen, etc.) is implicit in microbial growth. This growth and survival of microorganisms drives the geochemical cycling of the elements, detoxifies many contaminant organic compounds, makes essential nutrients present in the biomass of one generation available to the next, and maintains the conditions required by other inhabitants of the biosphere (3, 5, 14, 19, 20, 22). Processes carried out by microorganisms in soils, sediments, oceans, lakes, and groundwaters have a major impact on environmental quality, agriculture, and global climate change (1, 3, 5, 17, 23, 24). Thus, knowledge of environmental microbiology contributes significantly to knowledge of biosphere function.

The Oxford Companion to Philosophy (25) defines epistemology as “that branch of philosophy concerned with the nature of knowledge, its possibility, scope, and general basis”. However, epistemology does not exist only in philosophical realms. Six decades earlier, Cunningham (26) defined epistemology as “the science which sets forth and establishes the existence of true and certain human knowledge, the means of acquiring such knowledge, and the norm by which we can distinguish such knowledge from falsity”. In forging even stronger bonds between scientific inquiry and epistemology, Bateson (27) stated that epistemology is “a branch of biology”, it is “the process of the acquisition of information and its storage”, it is “the science of how we can know anything”. Despite the clear impetus for pursuing knowledge of environmental microbiology, throughout its history,

* Phone: 607-255-3086; fax: 607-255-3904; e-mail: elm3@cornell.edu.

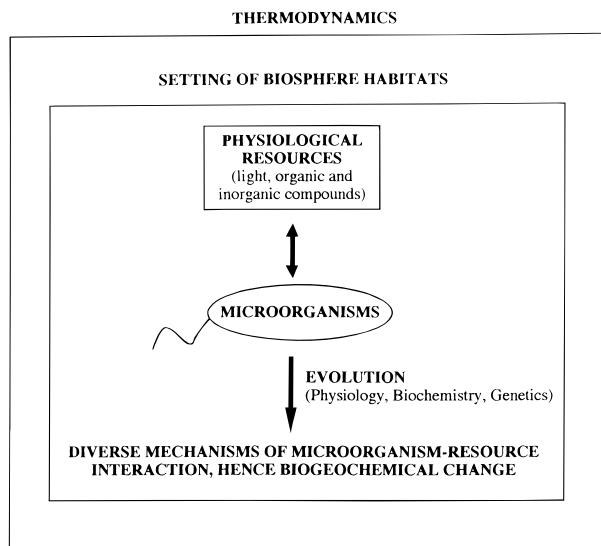

FIGURE 1. Conceptual basis for the development of microbial metabolic diversity. This diversity results from relationships between thermodynamics, the setting of biosphere habitats, physiological resources, microorganisms, and evolution. The largest box represents thermodynamics, governing all possible chemical reactions. The mid-sized box represents biosphere habitats where each specific context establishes the thermodynamic chemical instabilities of physiological resources used by microorganisms. The diversity of microorganisms and their biogeochemical capabilities continue to develop new ways to catalyze kinetically constrained reactions.

methodological limitations (16, 28–33) have impeded obtaining answers to fundamental questions such as “who, what, when, where, how, and why of microorganisms in the biosphere?”. The objectives of this paper are to examine constraints on knowledge of environmental microbiology and to describe how an integration and accrual of new methodologies into a continuum of field and molecular observations progressively advances the epistemological basis of environmental microbiology.

Constraints on Knowledge Imposed by Ecosystem Complexity

To know that microorganisms are the agents of geochemical change in soil, sediments, and waters, environmental microbiologists face the challenge of documenting both the change (e.g., conversion of plant biomass to CO_2 in sediments, nitrogen fixation in soil, or methane production in wetlands) and the role of microorganisms as causative agents. Microorganisms live and act in aquatic and terrestrial habitats whose complexities pose obstacles that impede directly measuring in situ activities of resident microorganisms. The soils, sediments, and waters where microorganisms dwell are poorly understood heterogeneous natural bodies, whose lateral and vertical boundaries occur as gradients between mixtures of materials of atmospheric, geologic, and/or biotic origin. These are continuous, open systems subject to fluxes of energy (e.g., sunlight, wind, tides) and materials (e.g., aqueous precipitation, erosion, deposition, infiltration, runoff) (Figure 2). Thus, accurate accounting of the masses of materials is difficult, if not impossible, in most habitats. Even if accounts of material fluxes through open system were accurate, another task remains—distinguishing microbial activities from the multiplicity of other processes (chemical, physical and physiological or other transformations carried out by higher organisms) that also influence field geochemical parameters. Except for photosynthesis by higher plants, most physiological reactions carried out by higher organisms are

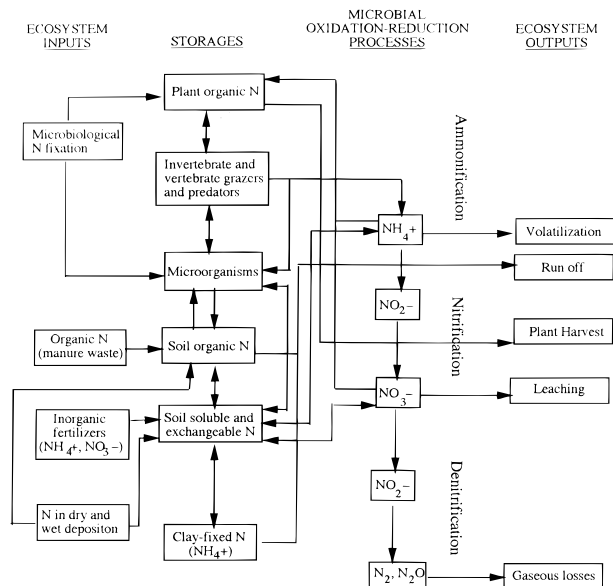

FIGURE 2. Flow model of nitrogen cycling in terrestrial ecosystems. Shown are basic inputs, storages, microbial processes, outputs, and both biotic and abiotic interactions. This diagram considerably simplifies the processes that actually occur in field sites because comparable reactions apply simultaneously and interactively to other nutrient elements (C, S, P, O, H, etc.). Thus, ecosystem complexity hinders obtaining knowledge of environmental microbiology (figure modified from Heal and Harrison; 35).

of little global significance. Yet in many localized habitats the contribution by plants and animals to the production, consumption, and transformation of geochemical materials cannot be ignored. Although interactions within food webs can be modeled (34; Figure 2), comprehensive documentation of the multiplicity of nutrient cycling, trophic, and biochemical interactions in field sites has yet to be achieved (35). Physical and chemical (abiotic) processes that must also be considered when measuring geochemical change in field settings include dilution, advection, dispersion, volatilization, sorption, photolysis, alteration by clay surfaces or other inorganic materials, and inorganic and organic equilibria (36–39; Figure 2). Furthermore, within each microbial habitat, complex synergistic geochemical changes are effected by consortia of microbial species (40, 41). Additional complexity of microbial activities in field sites stems from their dynamic changes in time and space. The physical, chemical, nutritional, and ecological conditions of microorganisms in field settings are heterogeneous and vary from the micrometer to beyond the kilometer scales (30, 31, 42, 43). Moreover, the biota and their respective physiological (e.g., growth rate, excretion, differentiation, death) and behavioral (e.g., migration, predation, competition, parasitism, symbiosis) activities respond to climate-induced and/or other environmental changes. Thus, if concentrations of ammonium (a key form of nitrogen) are found to fluctuate in lake sediments, interpreting such field measurements is very difficult: the ammonium pool at any given moment is controlled by processes of production (e.g., ammonification by microorganisms), consumption (e.g., nitrification by microorganisms, nutrient uptake by all organisms), and transport (e.g., entrainment in flowing water, diffusion, physical disturbances of sediment pore waters). Clearly, the many compounded intricacies of field habitats and microorganisms make their geochemical activities difficult to decipher.

Constraints on Knowledge Imposed by Methodologies

The methodological challenges of discerning microbial activities in soil, sediment, or water may perhaps best be

appreciated by considering how we know that higher plants carry out photosynthesis. In surveying a given landscape, humans can gather evidence for photosynthesis simply by noting the location of vegetation. Humans and the vegetation are roughly the same scale (\approx meter); therefore, detecting plants and their spatial relationships to one another and their habitats is facile. Photosynthesis is the major biogeochemical function of higher plants; without it there would be no plants nor food chains based thereupon. Thus, the presence of higher plants provides evidence for conversion of atmospheric CO₂ to biomass, and (because rooted plants are immobile) we simultaneously discern where the photosynthesis has occurred. At a mere glance then, humans gain plant-related biogeochemical knowledge addressing four key questions: who? (the plant), what? (photosynthesis), when? (recent history), and where? (the plant's location). To gain knowledge of the remaining two commonly asked key questions, "how?" and "why?", we rely on reductionistic biological disciplines that include physiology, biochemistry, genetics, and molecular biology—some of which can be applied to field-gathered plant samples or be manifest as chambers deployed to field sites. Now let us contrast how the six key questions pertinent to plant photosynthesis were answered with how the same questions are answered for metabolic activities of microorganisms in field habitats.

Limited Methods for Determining the Position and Composition of Microorganisms in Their Habitats. Microorganisms are small (on the order of micrometers). The million-fold discrepancy in size between humans and microorganisms ensures that gathering field samples for microscopic analysis will physically disturb both the microorganisms and their habitats. Microorganisms removed from their native environments have been characterized microscopically (44, 45). However, very little is known about the three-dimensional structure of microenvironments that surround microorganisms in field sites. New approaches such as transmission electron microscopy performed on thin sections of embedded samples and environmental scanning electron microscopy are developing for examining complex environments such as soil (46, 47). Yet, complete microscopic characterization of soil is a distant possibility because the soil biomass occupies only 0.001% of the soil volume (46). This means that a multitude of microscopic fields, each surveying a very small volume of soil, would need to be processed to obtain information accurately representing in situ spatial relationships of soil microorganisms. Thus, unlike plants in landscapes, detailed knowledge of where microorganisms dwell is very difficult to obtain because of scale-related and sampling-related physical characteristics of microhabitats and microorganisms therein.

To answer the question "Who is there?", environmental microbiologists have developed three general types of assays (24, 29, 32, 48–53): (i) viable plate counts of organisms able to grow on laboratory-incubated selective agar media; (ii) extraction and analysis of nucleic acids, phospholipids, or other cellular biomarkers; and (iii) microscopic examination of fixed, stained samples. Each of these methodologies has its own limitations. Common to all three is the high probability of overlooking members of microbial communities that may be functionally significant but may occur in low abundances and therefore be undetected. Results of viable plate count assays provide information about the small (\approx 1%) proportion of the initially diverse mixture of microorganisms that are able to grow under physiological conditions imposed by limited resources presented to the microorganisms in laboratory-incubated agar media (54, 55). Unmet challenges in designing the proper laboratory conditions for growing microorganisms are a major reason for such low cultivation efficiencies; but some microorganisms may also attain an unculturable physiological state (12).

Extraction of cell-specific biomarkers has proven to be effective for some cellular components (such as phospholipid fatty acids; 56–58) but susceptible to inefficiencies and biases for others (such as nucleic acids; 59–61). Nucleic acid extraction followed by cloning and sequencing of phylogenetically revealing 16S rRNA genes (8, 54, 55, 62–67; discussed further below) has recently provided evidence for novel residents of many habitats. When applied to a given field site, the results of this phenotype-free means of identifying microorganisms usually contrast strikingly with those of growth-based assays. However, physiological inferences from phenotype-free methodologies can be misleading because bacteria that are closely related by molecular criteria can display widely different biogeochemical capabilities (8).

The microscopic approach for characterizing naturally occurring microorganisms typically disperses an environmental sample (e.g., soil), preserves it with a chemical fixative, and smears a portion onto a glass slide where the key microbial components (especially nucleic acids, antigenic cell surfaces, or unique nucleic acid sequences) can be stained (with general nucleic acid-binding dyes, cell-specific antibodies, or with gene-specific oligonucleotide hybridization probes, respectively) to distinguish microbial cells from the inorganic and noncellular organic materials (29, 32, 48–52). General nucleic acid staining provides information on total microorganisms but usually falls short of providing information about the identity of individual cells because few types of microorganisms are morphologically distinctive. When microscopy is combined with cell-specific (antibody and nucleic acid) procedures designed to allow particular microorganisms to be recognized (8, 33, 54, 55, 62–70), it remains a challenge to verify the specificity and accuracy of results from cells that probe positively in complex naturally occurring communities.

Despite substantial sophistication in many of the above procedures assessing "Who is there?" in naturally occurring microbial communities, a complete census has yet to be successfully accomplished in any environment (32). Furthermore, of the 300 000–1 000 000 species of bacteria believed to exist globally (24), less than 5000 have been characterized in traditional culture collections (8), and approximately the same number of rRNA genes (from both cultured microorganisms and field-extracted nucleic acids) have been sequenced. Thus, there is much knowledge yet to be gained.

Limited Methods for Determining in Situ Biogeochemical Activities and When They Occur. Of the millions of microorganisms found in each cubic centimeter of soil, sediment, and water, there are thousands of species (24), each with complex genomes conferring the potential to carry out a variety of biogeochemical processes. Furthermore, many naturally occurring microorganisms exist as spores or other resting, completely dormant, or nonviable forms. Thus, unlike the clear link between the presence of higher plants and photosynthetic activity, the presence of microorganisms in environmental samples provides few clues about their specific physiological functions in situ.

The question "What are microorganisms doing?" can be subdivided into "What is the general physiological status of the cells?" and "What specific geochemical activities are the cells engaged in?". To assess the general physiological status of microorganisms in field sites, environmental microbiologists again rely on samples that are usually physically disturbed by removal from the field. And, similar to procedures inquiring about the composition of microbial communities (above), information about physiological status can be obtained from measurements conducted on laboratory-incubated samples, from biomarkers extracted from the samples, and/or via microscopic techniques (29, 32, 48–53). However, the physiological assays focus on key indicators

such as cellular contents of ribosomes (indicative of protein synthesis activity; 71); intracellular energy reserves (poly- β -hydroxyalkanoates, ATP; 57, 58, 72); membrane components reflecting nutritional status (proportions of *trans/cis* or cyclopropyl phospholipid fatty acids or electron transport carriers; 56–58); and time-course measurements of cell elongation, uptake of physiological substrates, or the reduction of dyes indicative of respiratory activity (the latter three assays are performed on laboratory-incubated environmental samples; 29, 32, 53). These kinds of assays are insightful, but each is limited in the information provided and carries artifactual risks (16, 29, 32; see below).

Methods for inquiring into the specific *in situ* geochemical activities catalyzed by microorganisms seek to document the impact of microbial activities on the chemical composition of soils, sediments, waters, and the atmosphere. For some microbial activities, the geochemical materials of interest or related microbial metabolites are volatile gases; hence, the underlying net microbial processes are measurable using field chambers placed over the surface of habitats being studied (73, 74). However, when neither the geochemical materials nor their metabolic products are volatile, documenting field metabolic processes requires more elaborate strategies that include physiologically guided chemical analysis of field samples, seeking stable isotopic fractionation patterns in field samples (75), field release of stable isotopically labeled materials, isolating a portion of the habitat for hypothesis-driven manipulations, *in situ* microelectrode measurements of chemical gradients (76, 77), probing for mRNAs and/or enzymes indicative of gene expression (78–81), and conducting physiological assays indicative of the metabolic activity of interest on laboratory-incubated field samples (16, 29, 32, 48–53). The credibility of such biogeochemical activity measures varies on a case-by-case basis with the habitat studied, the means of procedural implementation, and the microbiological process of interest. Most are influenced by uncertainties discussed below.

Accurate knowledge of temporal aspects of microbial activity in field sites, addressing the question, “When are the microorganisms active?”, is difficult to obtain. If field samples are fixed the moment they are gathered, then information subsequently gleaned after analysis completion can be considered indicative of the status of the microbial community at the time of sampling (32). This real time-type characterization of microorganisms in field sites is implicit in most field-chamber (73) and microelectrode (76) investigations and has recently been applied to biodegradation of environmental contaminants (82). But knowledge of when microorganisms carry out key biogeochemical reactions is often uncertain—inferred after the fact. Just as net photosynthesis in higher plants is inferred by the presence of plant biomass, microbial decay processes in steady-state ecosystems (e.g., salt marshes, forests, grasslands) can be inferred from the steady-state itself (35). Many ecosystems display productive seasons of plant growth that lead to the transfer of deceased biomass to soil and sediments. Yet, litter layers on the surface of soils and sediments do not constantly accrue. Thus, environmental microbiologists infer (after testing alternative hypotheses) that *in situ* microbially mediated decay processes counterbalance carbon inputs from photosynthesis. This large-scale mass-balance approach to ecosystem biogeochemistry has revealed essential insights into watershed processes (83), but the scale of resolution does not address the mechanistic biochemical intricacies sought by microbiologists.

Insights and Uncertainties from Model Systems Designed To Determine “What, Why, and How” of Microbial Biogeochemical Reactions. Assembling mass balances for geochemical components in field sites, distinguishing microbiological from other processes, and tracing circuitous

routes of geochemical materials through food chains and oxidation/reduction reactions are formidable tasks (see above; Figure 2). Many environmental microbiologists have confronted this situation and concluded that such adversities are nearly insurmountable in efforts aimed at discerning what microorganisms are doing in field sites (30–32, 84). The common way to contend with uncertainties of microbial activities is to initiate flask assays in the laboratory that monitor the chemical transformation(s) of interest in samples gathered from field sites. These laboratory assays provide definitive qualitative evidence for potential microbial metabolic reactions because sterilized or poisoned treatments can be examined as abiotic controls and mass balances are made possible by performing the assays in sealed vessels. For example, in the 1870s while examining microbial transformations of nitrogen, Schloesing and Müntz [cited in Waksman (3)] described a key link in the nitrogen cycle, nitrification, by reporting that nitrate was formed from ammonia in nonsterile but not in poisoned columns of sand infiltrated by sewage effluent. However, it is critical to acknowledge that measurements performed on laboratory-incubated environmental samples reveal what may be, but not necessarily what is, actually occurring in field sites.

A Heisenberg uncertainty-type principle is inescapable in environmental microbiology (32, 85) and must be confronted both in the examination of field site samples and in exploiting the spectrum of disciplines that contribute to our mechanistic understanding of microbiological processes. When one begins in a field site or with site-derived samples, the closer microorganisms are examined, the more likely the resultant information is to suffer from artifacts imposed by the measurement procedures. The basis for such artifacts is habitat disturbance (discussed above) and the responsiveness of both individual microorganisms and entire microbial communities to environmental change implicit in habitat disturbance (30–32). Environmental microbiologists generally agree that, given sufficient time, the microbial community present in every environmental sample will change according to selective pressures (resources and environmental conditions) imposed by removal of samples from their original location in field sites and by all intentional and unintentional laboratory incubation conditions (temperature, oxygen tension, physical disturbance, addition of nutrients or growth substrates, etc.). Of considerable controversy, however, is the amount of time required for microorganisms in environmental samples to respond to sampling and experimentally induced environmental changes. Implicit in many published investigations is the hypothesis that accurate qualitative and quantitative microbial activity determinations of *in situ* processes can be performed in the laboratory within a safe period before artifacts develop (32). This hypothesis has not been adequately tested. Yet, its validity is essential for the extrapolation of results from laboratory incubations to field sites (16, 32, 48–53, 86, 87). The alternative conservative methodological approach views laboratory incubations of environmental samples, at best, as a means toward estimating field processes. From the conservative viewpoint, quantitative extrapolation from laboratory results to actual field processes is taboo (16, 32) because the instant an environmental sample is removed from a field study site, intricate and tightly regulated genetic-, biochemical-, cellular-, and population-level changes may be triggered (32). It is the investigator's inability to obtain disturbance-free samples and to fully characterize, understand, and duplicate field conditions in the laboratory that undermine the acceptance of laboratory measurements performed on field samples as valid surrogates for true *in situ* field processes.

Controlled model laboratory experiments allow a logical reductionistic progression to proceed from field sample, to laboratory incubation, to enrichment cultures, to the isolation

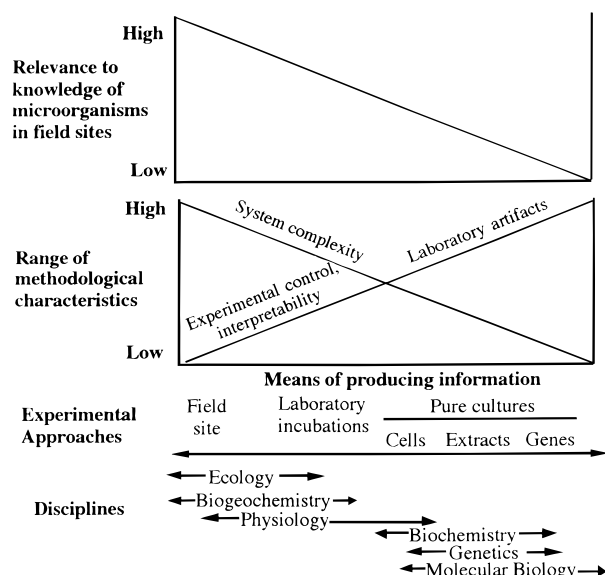

FIGURE 3. Relationships between means of producing information in environmental microbiology, their methodological characteristics, and their relevance to knowledge of microorganisms in field sites. As experimental approaches and corresponding disciplines become increasingly reductionistic (move from left to right), the relevance of the resultant information to microorganisms in field sites has traditionally diminished.

of pure cultures, and to elucidation of cellular and subcellular processes (Figure 3). This progression is the source of information presently available on ecological, physiological, biochemical, genetic, and molecular aspects of microbially mediated geochemical reactions. These model-system approaches are powerful because of the control attained in the laboratory and the use of experimental designs that can address specific hypotheses. Ironically, this reductionism is another basis for environmental microbiology's Heisenberg uncertainty principle. As each layer of reductionism unfolds, the complexity of the experimental system under scrutiny diminishes (Figure 3). But with each simplification step, the likelihood of the resultant information being ecologically relevant also diminishes. Perhaps the riskiest step in attempting to gain a mechanistic understanding of biogeochemical processes is the selection of pure cultures for study. With only a few exceptions (such as disease-causing agents or endosymbionts (88) whose ecological niche often allows them to act almost as pure cultures in nature), imperfect methodologies and the complexity of field sites (see above) have hampered environmental microbiologists' attempts to know which members of microbial communities are responsible for biogeochemical field processes (30–32). The environmental relevance of data from pure-culture studies conducted in the laboratory is suspect for at least two reasons: (i) The in situ geochemical change of interest is likely effected by intact naturally occurring microbial communities composed of complex mixtures of cells that often constitute intricate biochemical food webs (40, 41). Thus, the single organisms examined in pure-culture investigations are unlikely to be active or numerically dominant in nature and, therefore, may not be the correct objects of study. (ii) Even if the pure cultured organism being studied were responsible for the metabolic process in situ, the laboratory conditions used to grow and characterize the behavior of the organism may depart radically from the variety of influential in situ environmental factors (surfaces, colloids, gradients in substrate concentration, pH, final electron acceptors, etc.). The luxurious growth conditions sometimes provided in the laboratory may cause the metabolic process being studied to differ, quantitatively and perhaps qualita-

tively, from the process in situ where physical, chemical, and ecological constraints are likely to modify the organism's expression and regulation of genes (89).

In moving from left to right in the experimental approaches and scientific disciplines depicted in Figure 3, environmental microbiologists traverse from highly relevant but uncontrolled and sometimes uninterpretable field site measurements (Figure 2) to sophisticated, yet simplified, experimental systems increasingly likely to induce artifacts and hence be of uncertain relevance to microbiological processes in nature. The nucleic acid-based surveys of microorganisms described above usually fail to detect microorganisms obtained via culture-based procedures (8, 55); thus, the free-living noninfectious, nonendosymbiotic microbial model systems studied in pure culture that supply virtually all of our knowledge of biochemistry, genetics, and molecular biology may not be ecologically significant. This does not mean that the fundamental biochemical and genetic processes revealed by laboratory-grown pure cultures have no bearing on ecological matters; indeed, many cellular processes, such as nucleic acid replication, ribosome structure, and ATP generation are universal among virtually all life forms (90, 91). Furthermore, laboratory experiments conducted on environmental samples, mixed cultures, and pure cultures have been invaluable in elucidating basic physiological principles of methanogenesis, nitrification, denitrification, and photosynthesis (among others) that control nutrient cycling in field sites (see below). However, biochemical divergence between field and laboratory metabolic processes should not be unexpected for many ecologically significant biogeochemical processes.

State-of-the-Art Investigations and Major Environmental Microbiological Frontiers

The structure of knowledge in environmental microbiology emerges as an effort at balancing between real world significance of field sites and their puzzling complexity, between molecular insights from reductionism and the possible inapplicability of resultant information, and between fascinating intricacies and inescapable methodological simplifications. For each given field geochemical process, the activity (hence significance) of microorganisms as causative agents is inferred from multiple convergent lines of independent evidence (32, 85, 92–94). The lines of evidence rely on as many experimental approaches and scientific disciplines as are available (Figure 3). These are used to test alternative hypotheses, to consider all competing mechanisms, and to build compelling cases based on insights from field geochemistry, physiology, biochemistry, and molecular biology.

To illustrate environmental microbiology's current status and its dynamic character, details of five recent clusters of investigations have been compiled (Table 1). The broad objectives of all five investigations were to document biogeochemical processes catalyzed by microorganisms and how these both influenced and responded to geochemical characteristics of microbial habitats. The processes described in Table 1 include anaerobic respiratory reduction of sulfate to sulfide, biodegradation of organic contaminants, conversion of atmospheric to fixed nitrogen, the coupling of the oxidation of reduced sulfur compounds to autotrophic growth (CO₂ fixation), and photosynthesis. The microbial habitats examined range from coastal microbial mats, to submarine hydrothermal vents, to groundwater and adjacent soil, to tropical oceans. All of the investigations shown in Table 1 examined specific field sites where microorganisms clearly influenced site geochemistry by creating in situ gradients of metabolites (e.g., oxygen, sulfate, sulfide). Thus, determining key in situ geochemical parameters that both reflect and

TABLE 1. Selected Recent Investigations That Have Gained Knowledge of Microbiological Processes by Applying both Traditional and Innovative Biochemical or Molecular Methodologies to Field Sites^a

biogeochemical process	microbial habitat	methods		ref
		traditional ←	→ innovative	
sulfate reduction	coastal microbial mats	conduct field flux measurements of oxygen and carbon dioxide by sampling and analyzing changing concentrations of headspace gases in chambers placed over small-scale, stratified habitat; use micro-electrodes to measure oxygen profiles within mat pieces incubated with and without shading from ambient sunlight; inject radioactive sulfate into mat cores, incubate in laboratory, and analyze for appearance of radioactive sulfide	extract total RNA from 2-mm mat sections; blot the RNA onto nylon membranes; hybridize to five ³² P-labeled 16S rRNA-based oligonucleotide probes, each designed to distinguish between distinctive phylogenetic groups of the sulfate reducing bacteria; hybridize with universal probes for Archaea and all microorganisms; quantify the probe hybridization signals; compute relative abundances of each phylogenetic group at different depths in the mat	95, 96
biodegradation of organic contaminants	contaminated ground-water and adjacent soil	select coal tar waste-contaminated microbial habitat that is relatively simple geologically and hydrologically; assay ¹⁴ C ₂ production from ¹⁴ C-labeled contaminants added to laboratory-incubated soil and sediment samples; document in situ biodegradation by demonstrating community metabolic adaptation and detecting enhanced numbers of protozoan predators inside but not outside contaminant plume; measure oxygen depletion profiles in adjacent groundwater	extract nucleic acids from sediment; use pure culture-derived naphthalene biodegradation gene sequences to design PCR primers and amplify genes from extracted DNA and mRNA; use restriction enzymes to assess variability in gene sequences; use reverse transcriptase PCR to assess catabolic gene expression and diversity; extract organic compounds from site waters, use gas chromatography/mass spectrometry to identify a unique transient intermediary metabolite indicative of biodegradation	82, 97–100
nitrogen fixation	coastal microbial mats	remove mat cores, analyze for microorganism-specific photosynthetic pigments; enclose core samples, add acetylene, incubate in the laboratory, measure production of ethylene (this is a surrogate assay for nitrogen fixation activity); correlate nitrogen fixation activity with photosynthetic pigment abundances	extract DNA from two vertical zones in mat; use pure culture-derived nucleotide sequences for nitrogen fixation genes to design degenerate PCR primers; amplify portion of the <i>nifA</i> nitrogen fixation gene; explore genetic diversity by comparing found nucleotide and inferred amino acid sequences with those of pure cultures	86, 101
sulfur oxidation, CO ₂ fixation	submarine hydrothermal vents ^b	incubate field samples from sea floor sites amended with radiolabeled sulfur and CO ₂ ; measure conversion of the radiolabeled substrates to oxidized sulfur and biomass, respectively; extract and analyze microorganism-specific phospholipid cell membrane components; measure ratios of ¹³ C and ¹² C in organic and inorganic carbon compounds, seek evidence for isotopic fractionation caused by CO ₂ fixation	extract DNA; use PCR and 16S rRNA-based primers to prepare a library of 48 previously uncultured microorganism clones; use restriction enzymes to create characteristic RFLP patterns for each clone; identify 12 diverse RFLP patterns and determine the relative in situ abundance of each	16, 102–106
nitrogen and carbon fixation by the marine cyanobacterium, <i>Trichodesmium</i>	oligotrophic tropical oceans	gather and microscopically examine water samples during ocean cruises; measure the biomass of microorganisms and other associated organisms; conduct ship-based laboratory physiological assays of chlorophyll, growth, buoyancy, and CO ₂ and N ₂ fixation in water samples	extract DNA; use PCR to amplify <i>nifH</i> nitrogen fixation and 16S rDNA genes; conduct molecular phylogenetic analyses of <i>Trichodesmium's</i> evolutionary relationships to other N ₂ -fixing microorganisms; complete stable isotopic analyses suggesting that N ₂ fixation in ocean waters is the source of particulate organic nitrogen	107

^a The arrow connecting the two methods columns indicates that innovative procedures are assimilated into traditional environmental microbiological procedures. ^b Compiled from a variety of hydrothermal vent sites (16).

govern microbial physiological processes was critical for all five investigations. Also essential for these studies was the use of model systems—portions of the habitat of interest

were taken into the laboratory and amended (based on information provided by microbial physiologists) with a chemically distinguishable (radiotracer or other) substrate

whose alteration by site microorganisms was indicative of the geochemical metabolic processes of interest. Another common trait in the five investigations shown in Table 1 was the rapid processing of field samples using biochemical procedures to analyze cellular components. The methodologies described in Table 1 are divided into two columns, labeled "traditional" and "innovative". The arrow that connects these two categories of methods is designed to illustrate the dynamic state of methodologies, hence information and knowledge in environmental microbiology. All methods presently viewed as traditional were once innovative. For instance, the early 1970s marked the introduction of epifluorescent microscopic procedures, which provided new knowledge of the abundance and distribution of aquatic microorganisms (30, 31, 33). These epifluorescent procedures have since become broadly accepted and are considered traditional today. This pattern in which innovative methodologies are assimilated into traditional ones is the ongoing mechanism that ensures that hypotheses will be tested in new ways so that the knowledge of environmental microbiology will constantly grow, be refined, and asymptotically approach truth.

One of the most striking current innovations in environmental microbiology (well represented in column 4 of Table 1) is the nucleic acid-based approach for inquiring into microbial diversity (described above). Proposed in the mid 1980s (62), these procedures are founded on an understanding of the molecular phylogeny of ribosomal RNA and other genes that has revolutionized the evolutionary and taxonomic basis of biology (6–8). Other key developments essential for this type of inquiry were innovations in molecular biology and other disciplines that include microscopy, flow cytometry, nucleic acid sequencing procedures, the polymerase chain reaction, nucleic acid hybridization procedures, instrumentation for nucleotide sequence analyses, and electronic storage and retrieval of nucleotide sequences (54, 55, 62–67).

Another recent set of innovations elegantly uses gaseous metabolites found in field sites to infer the *in situ* physiological activities of native microbial populations. The partial pressure of hydrogen gas (a key transient intermediary metabolite in anaerobic food chains) has been shown to occur in anaerobic habitats at discrete nanomolar concentrations that are diagnostic for methanogenesis, sulfate reduction, iron reduction, and denitrification (108, 109). In addition, knowledge of isotopic fractionation processes can reveal how microorganisms control the geochemistry of their habitats (75). For instance, the carbon dioxide found in field sites has different $^{13}\text{C}/^{12}\text{C}$ ratios depending on the $^{13}\text{C}/^{12}\text{C}$ signature of the substrates respired and the ^{13}C -enriching process of methanogenesis. When site-specific signatures of both inorganic and organic carbon reservoirs have been characterized, the relative contribution of each to the pool of CO_2 can be discerned (110). The radioactive (^{14}C) component of CO_2 is also revealing because the different carbon pools may have distinctive ages (111).

The information compiled in Table 2 extends the investigation-specific details presented in Table 1 in a manner that addresses the six key questions (raised above) about geochemical reactions catalyzed by microorganisms in their habitats. Included in Table 2 are partial compilations of the significance of the key questions and associated enduring issues for environmental microbiology. To emphasize the dynamic status of environmental microbiological knowledge, Table 2 also partially compiles traditional methods for answering the questions, innovative methodological improvements and their bases, and examples of recent knowledge stemming from the innovations.

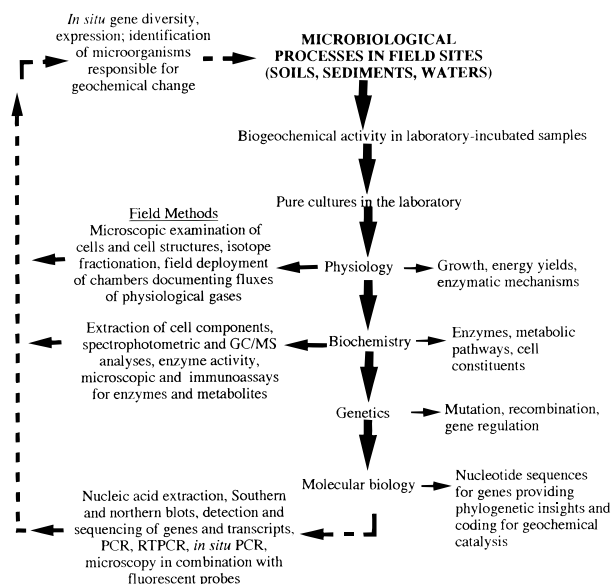

FIGURE 4. Paradigm for the development of new methodologies capable of extending knowledge of environmental microbiology. Relationships between microorganisms responsible for field biogeochemical processes, reductionistic disciplines, and their application to microorganisms in field sites are depicted. The three different types of arrows indicate sequential refinements in biological disciplines (large downward-pointing solid arrows), resultant information (small arrows pointing to the right), and recent innovative methodological applications to naturally occurring microbial communities (dotted arrows). Abbreviations: GC/MS, gas chromatography/mass spectrometry; PCR, polymerase chain reactions; RT, reverse transcriptase.

Overcoming Constraints on Knowledge: Accrual and Integration of New Methods Applied to Field Sites

Constraints on obtaining answers to the fundamental questions in environmental microbiology (see above) are fixed, static, and have lingered since the nineteenth century (3, 30–32). Field sites will always be complex, and the two manifestations of the Heisenberg uncertainty principle (microbial populations change when disturbed and reductionistic model systems may not be ecologically relevant) are enduring conundrums. However, advances continue in the disciplines that deliver to environmental microbiology new technologies, new methods, and new insights (Figure 3, Tables 1 and 2). The path to knowledge of field microbiological processes has always involved multidisciplinary approaches, assembling convergent lines of independent evidence, and testing alternative hypotheses (16, 32, 85, 92–94, 107). Ongoing integration of new methodologies into environmental microbiology ensures that the number of lines and the robustness of both their convergence and their tests will increase. A conceptual paradigm that graphically depicts the synergistic relationship between microbiological processes in field sites, reductionistic biological disciplines, and iterative methodological linkages between these disciplines is presented in Figure 4. Observations of microorganisms in natural settings instigate a series of procedures progressing through mixed cultures; pure cultures; and physiological, biochemical, genetic, and molecular biological inquiries that each stand alone scientifically. But appreciable new knowledge of naturally occurring microorganisms is gained when advancements from the pure biological sciences are directed back to microorganisms in their field habitats. These methodological advancements (shown as dotted arrows in Figure 4) and the knowledge they generate accrue with each new cycle from field observations to molecular biology and back. One particularly promising

TABLE 2. Major Questions in Environmental Microbiology, Their Significance, Enduring Issues, and the Means by Which Traditional Approaches to Answers Have Recently Been Innovatively Improved To Produce Recent Knowledge

question	significance	enduring issues	traditional methods	scientific basis for methodological innovations	applications of methodological innovations to field processes	recent knowledge	ref
who is there?	bacteria, fungi, algae, protozoa, and viruses are ubiquitously distributed throughout the biosphere	the majority of microorganisms in the multitude of environments comprising the biosphere have not been cultivated or characterized; because so much is unknown, microbial diversity is a rapidly expanding area in environmental microbiology	viable counts of microorganisms on enrichment media; microscopy using a variety of cellular and subcellular visualization procedures	gene sequencing and molecular phylogeny of 16S rRNA and other taxonomically significant genes; polymerase chain reaction; sequencing of entire genomes; characterization of other key biomarkers (phospholipids, cell walls, photosynthetic pigments, electron carriers, etc.); advances in microscopy, flow cytometry, immunodiagnosics	efficient culturing procedures based on dilution of microorganisms in waters from aquatic habitats; assessment of growth using flow cytometry; extract rDNA or rRNA from microbial communities; clone, sequence, and analyze 16S rRNA genes to identify novel organisms; microscopically probe communities for cells that hybridize with fluorescently labeled oligonucleotides; separate with laser tweezers; cultivate, characterize	extended knowledge of phylogeny and taxonomy of extant microorganisms; assessment of ecological prevalence of specific microorganisms	8, 24, 54, 55, 62–68, 70, 112–119
what are they doing?	microorganisms catalyze a variety of nutrient cycling-related biogeochemical processes	mechanisms of microbiological processes have been only partially explored; existing knowledge is based on a limited set of pure culture laboratory systems	laboratory experiments using samples of soil, sediments, and water to examine potential environmental, ecological, and biogeochemical reactions catalyzed by naturally occurring microbial communities	continued elective enrichment procedures; isolation and characterization of diverse microorganisms capable of novel biogeochemical processes; description of biochemical and molecular mechanisms underlying biogeochemical processes	examine DNA, mRNA, enzymes, other macromolecules, and intermediary metabolites in environmental samples; a variety of microscopic and molecular analytical procedures for exploring biochemical diversity and function may be implemented	diversity of functional genes in naturally occurring microbial communities	16, 32, 56–58, 68, 69, 81, 93–95, 97–99, 120–129
how and why are they active?	the significance of these processes raises additional ecological concerns that include growth, dormancy, and genetic exchange	robust means for extrapolating laboratory data to field sites are needed; agents of biogeochemical change in field sites need to be identified; mechanisms of genetic change and exchange are poorly understood in natural systems				extended knowledge of distribution and variation of genes coding for biogeochemical reactions	

when and where are they active? spatial and temporal controls of microbial activity are poorly understood in virtually all field sites

physical, chemical, and biological heterogeneities that contribute to field site complexity and gradients of resources utilized by microorganisms in their habitats are poorly understood; factors that control microbial field processes need to be understood; controls include molecular signals, physical, chemical, and environmental characteristics, and cell-cell interactions (including symbiosis, predator-prey, parasitism, competition, and antagonism)

a variety of aseptic sampling, fixation, and microscopic examination assays; install chambers, piezometers for monitoring changes in volatile or soluble analytes; whole-watershed studies that compare mass balance and flux measurements

sensors and field characterization and sampling procedures that can be combined with physiological, biochemical, genetic, and molecular assays

deploy sensors, chemicals and/or microorganisms in field sites; extract key enzymes or intermediate metabolites; measure and interpret stable isotope fractionation patterns; use microsensors to document concentration gradients in situ

inquiries into specific in situ biogeochemical activities catalyzed by microorganisms in real time

29, 32, 73-80, 82, 86, 87, 93, 94, 100, 104, 108-111, 127

strategy for inquiry into the genetic diversity of microbial metabolic capabilities is to bypass the "pure cultures" step in Figure 4 by creating genomic libraries directly from environmental samples (130-132). These can then be screened for a variety of previously undiscovered genes and gene products. The static constraints on knowledge in environmental microbiology have been yielding and will continue to yield at an accelerating rate to the dynamic accruing advancements that arise when new methodologies are applied to field sites. This bodes well for the future of environmental microbiology and its impacts on biosphere management and biotechnological products and services.

Acknowledgments

Support from the Air Force Office of Scientific Research (Grants AFOSR-91-436, F49620-93-1-0414, and F49620-95-1-0346); by the Cornell Biotechnology Program, which is sponsored by the New York State Science and Technology Foundation, a consortium of industries, and the National Science Foundation; and the NIEHS/Superfund Basic Research and Education Program (Grant ES-05950-03) is gratefully acknowledged. I thank W. C. Ghiorse, J. B. Yavitt, and S. H. Zinder for discussions assisting in the development of ideas presented here and four anonymous reviewers and the editor (J. M. Suflita), who contributed many key refinements.

Literature Cited

- (1) Atlas, R. M.; Bartha, R. *Microbial Ecology: Fundamentals and Applications*, 4th ed.; Benjamin/Cummings Publishing Co.: Menlo Park, CA, 1997.
- (2) Winogradsky, S. *Microbiologie du sol, problèmes et méthodes; cinquante ans de recherches. Oeuvres complètes*; Masson: Paris, 1949.
- (3) Waksman, S. A. *Principles of Soil Microbiology*; Williams & Wilkins, Co.: Baltimore, MD, 1927.
- (4) Hurst, C. J. In *Manual of Environmental Microbiology*; Hurst, C. J., Knudsen, G. R., McInerney, M. J., Stetzenbach, L. D., Walter M. V., Eds.; ASM Press: Washington, DC, 1997; pp 3-4.
- (5) Madigan, M. T.; Martinko, J. M.; Parker, J. *Biology of Microorganisms*, 8th ed.; Prentice Hall: Englewood Cliffs, NJ, 1997.
- (6) Woese, C. R. *Microbiol. Rev.* **1987**, *51*, 221-271.
- (7) Stackebrandt, E. In *The Prokaryotes*, 2nd ed.; Balows, A., Trüper, H. G., Dworkin, M., Harder, W., Schleifer, K.-H., Eds.; Springer-Verlag: New York, 1992; pp 19-47.
- (8) Pace, N. *Science* **1997**, *276*, 734-740.
- (9) Strickberger, M. W. *Evolution*, 2nd ed.; Jones and Bartlett Publishers: Sudbury, MA, 1996.
- (10) Ryan, K. J., Ed. *Sherris Medical Microbiology: An Introduction to Infectious Diseases*, 3rd ed.; Appleton and Lange: Norwalk, CT, 1994.
- (11) Demain, A. L., Soloman, N. A., Eds. *Biology of Industrial Microorganisms*; Benjamin-Cummings Publishing Co.: Menlo Park, CA, 1985.
- (12) Colwell, R. R.; Clayton, R. A.; Ortiz-Conde, B. A.; Jacobs, D.; Russek-Cohen, E. In *Microbial Diversity and Ecosystem Function*; Allsopp, D., Colwell, R. R., Hawksworth, D. L., Eds.; CAB International: Wallingford, U.K., 1992; pp 3-15.
- (13) Bull, A. T.; Goodfellow, M.; Slater, J. H. *Annu. Rev. Microbiol.* **1992**, *46*, 219-252.
- (14) Dworkin, M. In *The Prokaryotes*, 2nd ed.; Balows, A., Trüper, H. G., Dworkin, M., Harder, W., Schleifer, K.-H., Eds.; Springer-Verlag: New York, 1992; pp 48-74.
- (15) Ehrlich, H. L. *Geomicrobiology*, 3rd ed.; Marcel Dekker, Inc.: New York, 1995.
- (16) Karl, D. M. In *The Microbiology of Deep Sea Hydrothermal Vents*; Karl, D. M., Ed.; CRC Press: New York, 1995; pp 35-124.
- (17) Schlegel, H. G.; Jannasch, H. W. In *The Prokaryotes*, 2nd ed.; Balows, A., Trüper, H. G., Dworkin, M., Harder, W., Schleifer, K.-H., Eds.; Springer-Verlag: New York, 1992; pp 75-125.
- (18) Leadbetter, E. R. In *Manual of Environmental Microbiology*; Hurst, C. J., Knudsen, G. R., McInerney, M. J., Stetzenbach, L. D., Walter, M. V., Eds.; ASM Press: Washington, DC, 1997; pp 14-24.
- (19) Rayner, A. D. M. In *Microbial Diversity and Ecosystem Function*; Allsopp, D., Colwell, R. R., Hawksworth, D. L., Eds.; CAB International: Wallingford, U.K., 1995; pp 231-251.

- (20) Zehnder, A. J. B.; Stumm, W. In *Biology of Anaerobic Microorganisms*; Zehnder, A. J. B., Ed.; John Wiley & Sons, Inc.: New York, 1988; pp 1–38.
- (21) Devlin, T. M., Ed. *Textbook of Biochemistry with Clinical Correlations*; Wiley-Liss: New York, 1997.
- (22) Waksman, S. A. *Science* **1945**, *102*, 339–344.
- (23) Schlesinger, W. H. *Biogeochemistry: An analysis of Global Change*; Academic Press: San Diego, CA, 1991.
- (24) Tiedje, J. M. In *Microbial Diversity and Ecosystem Function*; Allsopp, D., Colwell, R. R., Hawksworth, D. L., Eds.; CAB International: Wallingford, U.K., 1995; pp 73–97.
- (25) Honderich, T., Ed. *The Oxford Companion to Philosophy*; Oxford University Press: Oxford, 1995.
- (26) Cunningham, W. F. *Notes on Epistemology*; Declan X. McMullen Co., Inc.: New York, 1930.
- (27) Bateson, G. In *A Sacred Unity*; Donaldson, R. E., Ed.; Harper Collins Publishers: New York, 1991.
- (28) Brock, T. D. In *Ecology of Microbial Communities*, Forty-first Symposium of the Society for General Microbiology; Cambridge University Press: New York, 1987; pp 1–17.
- (29) Karl, D. M. In *Bacteria in Nature*; Poindexter, J. S., Leadbetter, E. R., Eds.; Plenum Press: New York, 1986; Vol. 2, pp 85–176.
- (30) Hobbie, J. E. In *Handbook of Methods in Aquatic Microbial Ecology*; Kemp, P. F., Sherr, B. F., Sherr, E. B., Cole, J. J., Eds.; Lewis Publishers: Boca Raton, FL, 1993; pp 1–5.
- (31) Hobbie, J. E.; Ford, T. E. In *Aquatic Microbiology*; Ford, T. E., Ed.; Blackwell Scientific Publishers: Boston, MA, 1993; pp 1–14.
- (32) Madsen, E. L. In *Soil Biochemistry*, Vol. 9; Stotzky, G., Bollag, J.-M., Eds.; Marcel Dekker, Inc.: New York, 1996; pp 287–370.
- (33) Paul, J. H. In *Aquatic Microbiology*; Ford, T. E., Ed.; Blackwell Scientific Publishers: Boston, MA, 1993; pp 15–46.
- (34) Parton, W. J.; Stewart, J. W. B.; Cole, C. V. *Biogeochemistry* **1988**, *5*, 109–131.
- (35) Heal, O. W.; Harrison, A. F. In *Nutrient Cycling in Terrestrial Ecosystems: Field Methods, Application and Interpretation*; Harrison, A. F., Ineson, P., Heal, O. W., Eds.; Elsevier Applied Science: London, 1990; pp 170–178.
- (36) Mansour, M.; Feicht, E. A. *Chemosphere* **1994**, *28*, 323–332.
- (37) Wolfe, N. L. *Abiotic Transformations of Pesticides in Natural Waters and Sediments*; John Wiley & Sons, Inc.: New York, 1992.
- (38) Thibodeaux, L. J. *Environmental Chemodynamics*, 2nd ed.; John Wiley & Sons: New York, 1995.
- (39) Stumm, W.; Morgan, J. J. *Aquatic Chemistry*, 3rd ed.; John Wiley & Sons: New York, 1996.
- (40) Gottschal, J. C.; Harder, W.; Prins, R. A. In *The Prokaryotes*, 2nd ed.; Balows, A., Trüper, H. G., Dworkin, M., Harder, W., Schleifer, K.-H., Eds.; Springer-Verlag: New York, 1992; pp 149–196.
- (41) Zinder, S. H. In *Methanogenesis: Ecology, Physiology, Biochemistry, and Genetics*; Ferry, J. G., Ed.; Chapman and Hall: New York, 1993; pp 128–206.
- (42) Groffman, P. M. *Agriculture Research in the Northeastern United States: Critical Review and Future Perspectives*; ASA: Madison, WI, 1993; pp 19–26.
- (43) Parkin, T. B. *J. Environ. Qual.* **1993**, *22*, 409–417.
- (44) Caldwell, D. E.; Korber, D. R.; Lawrence, J. R. *Adv. Microb. Ecol.* **1993**, *12*, 1–67.
- (45) Sieburth, J. M. *Microbial Seascapes: A Pictorial Essay on Marine Microorganisms and Their Environment*; University Park Press: Baltimore, MD, 1975.
- (46) Foster, R. C. In *Soil Micromorphology: Studies in Management and Genesis*; Ringrose-Voase, A. J., Humphreys, G. S., Eds.; Elsevier: New York, 1993; pp 381–393.
- (47) Ladd, J. N.; Foster, R. C.; Nannipieri, P.; Oades, J. M. In *Soil Biochemistry*, Vol. 9; Stotzky, G., Bollag, J.-M., Eds.; Marcel Dekker, Inc.: New York, 1996; pp 23–78.
- (48) Hurst, C. J.; Knudsen, G. R.; McInerney, M. J.; Stetzenbach, L. D.; Walter M. V., Eds. *Manual of Environmental Microbiology*; American Society for Microbiology: Washington, DC, 1997.
- (49) Kemp, P. F.; Sherr, B. F.; Sherr, E. B.; Cole, J. J., Eds. *Handbook of Methods in Aquatic Microbial Ecology*; Lewis Publishers: Boca Raton, FL, 1993.
- (50) Levin, M. A.; Seidler, R. J.; Rogul, M., Eds. *Microbial Ecology: Principles, Methods, and Applications*; McGraw-Hill, Inc.: New York, 1992.
- (51) Weaver, R. W. et al., Eds. *Methods of Soil Analysis Part 2. Microbiological and Biochemical Properties*; Soil Science Society of America: Madison, WI, 1994.
- (52) Burlage, R., Ed. *Techniques in Microbial Ecology*; Oxford University Press: New York, 1997.
- (53) Staley, J. T.; Konopka, A. *Annu. Rev. Microbiol.* **1985**, *39*, 321–346.
- (54) Amann, R. I.; Ludwig, W.; Schleifer, K.-H. *Microbiol. Rev.* **1995**, *59*, 143–169.
- (55) Ward, D. M.; Bateson, M. M.; Weller, R.; Ruff-Roberts, A. L. *Adv. Microb. Ecol.* **1993**, *12*, 219–286.
- (56) Findlay, R. H.; Dobbs, F. C. In *Handbook of Methods in Aquatic Microbial Ecology*; Kemp, P. F., Sherr, B. F., Sherr, E. B., Cole, J. J., Eds.; Lewis Publishers: Chelsea, MI, 1993; pp 271–284.
- (57) Tunlid, A.; White, D. C. In *Soil Biochemistry*, Vol. 7; Stotzky, G., Bollag, J.-M., Eds.; Marcel Dekker: Inc.: New York, 1992; pp 229–262.
- (58) White, D. C.; Pinkart, H. C.; Ringelberg, D. B. In *Manual of Environmental Microbiology*; Hurst, C. J., Knudsen, G. R., McInerney, M. J., Stetzenbach, L. D., Walter M. V., Eds.; ASM Press: Washington, DC, 1997; pp 91–101.
- (59) Farrelly, V.; Rainey, F. A.; Stackebrandt, E. *Appl. Environ. Microbiol.* **1995**, *61*, 2798–2801.
- (60) Moré, M. I.; Herrick, J. B.; Silva, M. C.; Ghiorse, W. C.; Madsen, E. L. *Appl. Environ. Microbiol.* **1994**, *60*, 1572–1580.
- (61) Suzuki, M. T.; Giovannoni, S. J. *Appl. Environ. Microbiol.* **1996**, *62*, 625–630.
- (62) Pace, N. R.; Stahl, D. A.; Lane, D. J.; Olsen, G. J. *Adv. Microb. Ecol.* **1986**, *9*, 1–55.
- (63) Barns, S. M.; Fundyga, R. E.; Jeffries, M. W.; Pace, N. R. *Proc. Natl. Acad. Sci. U.S.A.* **1994**, *91*, 1609–1613.
- (64) Giovannoni, S. J.; Britschgi, T. B.; Moyer, C. L.; Field, K. G. *Nature* **1990**, *345*, 60–63.
- (65) Stahl, D. A. In *Manual of Environmental Microbiology*; Hurst, C. J., Knudsen, G. R., McInerney, M. J., Stetzenbach, L. D., Walter M. V., Eds.; ASM Press: Washington, DC, 1997; pp 102–114.
- (66) Ward, N.; Rainey, F. A.; Goebel, B.; Stackebrandt, E. In *Microbial Diversity and Ecosystem Function*; Allsopp, D., Colwell, R. R., Hawksworth, D. L., Eds.; CAB International: Wallingford, U.K., 1995; pp 89–110.
- (67) Barns, S. M.; Delwiche, C. F.; Palmer, J. C.; Pace, N. R. *Proc. Natl. Acad. Sci. U.S.A.* **1996**, *93*, 9188–9193.
- (68) Ward, B. B. *Limnol. Oceanogr.* **1984**, *29*, 402–410.
- (69) Currin, C. A.; Paerl, H. W.; Suba, G. K.; Alberte, R. S. *Limnol. Oceanogr.* **1990**, *35*, 59–71.
- (70) Siering, P. L.; Ghiorse, W. C. *Appl. Environ. Microbiol.* **1996**, *63*, 644–651.
- (71) Kemp, P. F.; Lee, S.; LaRoche, J. In *Handbook of Methods in Aquatic Microbial Ecology*; Kemp, P. F., Sherr, B. F., Sherr, E. B., Cole, J. J., Eds.; Lewis Publishers: Boca Raton, FL, 1993; pp 415–422.
- (72) Karl, D. M. In *Handbook of Methods in Aquatic Microbial Ecology*; Kemp, P. F., Sherr, B. F., Sherr, E. B., Cole, J. J., Eds.; Lewis Publishers: Chelsea, MI, 1993; pp 483–494.
- (73) Conrad, R. *Microbiol. Rev.* **1996**, *60*, 609–640.
- (74) Yavitt, J. B.; Lang, G. E.; Sexstone, A. J. *J. Geophys. Res.* **1990**, *95*, 22463–22474.
- (75) Grossman, E. L. In *Manual of Environmental Microbiology*; Hurst, C. J., Knudsen, G. R., McInerney, M. J., Stetzenbach, L. D., Walter M. V., Eds.; ASM Press: Washington, DC, 1997; pp 565–576.
- (76) Glud, R. N.; Gundersen, J. K.; Revsbech, N. P.; Jørgensen, B. B. *Limnol. Oceanogr.* **1994**, *39*, 462–467.
- (77) Revsbech, N. P.; Jørgensen, B. B. *Adv. Microb. Ecol.* **1986**, *9*, 293–352.
- (78) Pichard, S. L.; Paul, J. H. *Appl. Environ. Microbiol.* **1993**, *59*, 451–457.
- (79) Ogram, A.; Sun, W.; Brockman, F. J.; Fredrickson, J. K. *Appl. Environ. Microbiol.* **1995**, *61*, 763–768.
- (80) Ogunseitan, O. A. *J. Microbiol. Methods* **1997**, *28*, 55–63.
- (81) Hodson, R. E.; Dustman, W. A.; Garg, R. P.; Moran, M. A. *Appl. Environ. Microbiol.* **1995**, *61*, 4074–4082.
- (82) Wilson, M. S.; Madsen, E. L. *Environ. Sci. Technol.* **1996**, *30*, 2099–2103.
- (83) Likens, G. E.; Bormann, F. H. *Biogeochemistry of a Forested Ecosystem*; Springer-Verlag: New York, 1995.
- (84) Bull, A. T. In *Contemporary Microbial Ecology*; Ellwood, D. C., Hedger, J. N., Latham, M. J., Lynch, J. M., Slater, J. H., Eds.; Academic Press: New York, 1980; pp 107–136.
- (85) Madsen, E. L. *Environ. Sci. Technol.* **1991**, *25*, 1662–1673.
- (86) Pinckney, J.; Paerl, H. W.; Fitzpatrick, M. *Mar. Ecol. Prog. Ser.* **1995**, *123*, 207–216.
- (87) Tiedje, J. M.; Simkins, S.; Groffman, P. M. *Plant Soil* **1989**, *115*, 261–284.
- (88) Ruby, E. G. *Annu. Rev. Microbiol.* **1996**, *50*, 591–624.
- (89) Lindow, S. E. *Mol. Ecol.* **1995**, *4*, 555–566.
- (90) Klyuyver, A. J.; van Niel, C. B. *The Microbe's Contribution to Biology*; Harvard University Press: Cambridge, MA, 1954.
- (91) Neidhardt, F. C.; Ingraham, J. I.; Schaechter, M. *Physiology of the Bacterial Cell*; Sinauer Assoc., Inc.: Sunderland, MA, 1990.

- (92) McKay, D. S.; et al. *Science* **1996**, *273*, 924–930.
- (93) Stevens, T. O.; McKinley, J. P. *Science* **1995**, *270*, 450–454.
- (94) Krumholz, L. R.; McKinley, J. P.; Ulrich, G. A.; Sufliata, J. M. *Nature* **1997**, *386*, 64–66.
- (95) Canfield, D. E.; Des Marais, D. J. *Geochim. Cosmochim. Acta* **1993**, *57*, 3971–3984.
- (96) Risatti, J. B.; Chapman, W. C.; Stahl, D. A. *Proc. Natl. Acad. Sci. U.S.A.* **1994**, *91*, 10173–10177.
- (97) Herrick, J. B.; Madsen, E. L.; Batt, C. A.; Ghiorse, W. C. *Appl. Environ. Microbiol.* **1993**, *59*, 687–694.
- (98) Madsen, E. L.; Sinclair, J. L.; Ghiorse, W. C. *Science* **1991**, *252*, 830–833.
- (99) Murarka, I.; Neuhauser, E.; Sherman, M.; Taylor, B. B.; Mauro, D. M.; Ripp, J.; Taylor, T. *J. Hazard. Mater.* **1992**, *32*, 245–261.
- (100) Wilson, M. S.; Madsen, E. L. *Abstract*, American Society for Microbiology Annual Meeting, Miami, FL, 1997; N-142; p 404.
- (101) Zehr, J. P.; Mellon, M.; Braun, S.; Litaker, W.; Steppe, T.; Paerl, H. W. *Appl. Environ. Microbiol.* **1995**, *61*, 2527–2532.
- (102) Hedrick, D. B.; Pledger, R. D.; White, D. C.; Baross, J. A. *FEMS Microbiol. Ecol.* **1992**, *101*, 1–10.
- (103) Jannasch, H. W. In *Autotrophic Bacteria*; Schlegel, H. G., Bowien, B., Eds.; Science Tech Publishers: Madison, WI, 1989; pp 147–166.
- (104) Kennicutt, M. C., II; Burke, R. A., Jr. In *The Microbiology of Deep Sea Hydrothermal Vents*; Karl, D. M., Ed.; CRC Press: New York, 1995; pp 275–287.
- (105) Moyer, C. L.; Dobbs, F. C.; Karl, D. M. *Appl. Environ. Microbiol.* **1994**, *60*, 871–879.
- (106) Tuttle, J. H. *Biol. Soc. Wash. Bull.* **1985**, *6*, 335–343.
- (107) Capone, D. B.; Zehr, J. P.; Paerl, H. W.; Bergman, B.; Carpenter, E. J. *Science* **1997**, *226*, 1221–1229.
- (108) Lovley, D. R.; Chapelle, F. H.; Woodward, J. C. *Environ. Sci. Technol.* **1994**, *28*, 1205–1210.
- (109) Chapelle, F. H.; Vroblesky, D. A.; Woodward, J. C.; Lovley, D. R. *Environ. Sci. Technol.* **1997**, *31*, 2873–2877.
- (110) Landemeyer, J. E.; Vroblesky, D. A.; Chapelle, F. H. *Environ. Sci. Technol.* **1996**, *30*, 1120–1128.
- (111) Conrad, M. E.; Daley, P. F.; Fischer, M. L.; Buchanan, B. B.; Leighton, T.; Kashgarian, M. *Environ. Sci. Technol.* **1997**, *31*, 1463–1469.
- (112) Button, D. K.; Schut, F.; Quang, P.; Martin, R.; Robertson, B. R. *Appl. Environ. Microbiol.* **1993**, *59*, 881–891.
- (113) Ferris, M. J.; Muyzer, G.; Ward, D. M. *Appl. Environ. Microbiol.* **1996**, *62*, 340–346.
- (114) Huber, R.; Burggraf, S.; Mayer, T.; Barns, S. M.; Rossmagel, P.; Stetter, K. O. *Nature* **1995**, *376*, 57–58.
- (115) Holben, W. E.; Harris, D. *Mol. Ecol.* **1995**, *4*, 627–631.
- (116) Holben, W. E. In *Manual of Environmental Microbiology*; Hurst, C. J., Knudsen, G. R., McInerney, M. J., Stetzenbach, L. D., Walter M. V., Eds.; ASM Press: Washington, DC, 1997; pp 431–436.
- (117) Ogram, A.; Feng, X. In *Manual of Environmental Microbiology*; Hurst, C. J., Knudsen, G. R., McInerney, M. J., Stetzenbach, L. D., Walter M. V., Eds.; ASM Press: Washington, DC, 1997; pp 422–430.
- (118) Wawer, C.; Muyzer, G. *Appl. Environ. Microbiol.* **1995**, *61*, 2203–2210.
- (119) Liu, W.-T.; Marsh, T. L.; Cheng, H.; Forney, L. J. *Appl. Environ. Microbiol.* **1997**, *63*, 4516–4522.
- (120) Fleming, J. T.; Sanseverino, J.; Sayler, G. S. *Environ. Sci. Technol.* **1993**, *27*, 1068–1074.
- (121) Sayler, G. S.; Layton, A.; Lajoie, C.; Bowman, J.; Tschantz, M.; Fleming, J. T. *Appl. Biochem. Biotechnol.* **1995**, *54*, 277–290.
- (122) van der Meer, J. R. *Antonie van Leeuwenhoek* **1997**, *71*, 159–178.
- (123) Williams, P. A.; Sayers, J. R. *Biodegradation* **1994**, *5*, 195–217.
- (124) Zylstra, G. J. In *Molecular Environmental Biology*; Garte, S. J., Ed.; Lewis Publishers Inc.: Boca Raton, FL, 1983; pp 83–115.
- (125) Brockman, F. J. *Mol. Ecol.* **1995**, *4*, 567–578.
- (126) Byrne, A. M.; Kukor, J. J.; Olsen, R. H. *Gene* **1995**, *154*, 65–70.
- (127) Harkness, M. R.; et al. *Science* **1993**, *259*, 503–507.
- (128) De Souza, M. L.; Sadowsky, M. J.; Wackett, L. P. *J. Bacteriol.* **1996**, *178*, 4894–4900.
- (129) Herrick, J. B.; Stuart-Keil, K. G.; Ghiorse, W. C.; Madsen, E. L. *Appl. Environ. Microbiol.* **1997**, *63*, 2330–2337.
- (130) Healy, F. G.; Ray, R. M.; Aldrich, H. C.; Wilkie, A. C.; Ingram, L. O.; Shanmugam, K. T. *Appl. Microbiol. Biotechnol.* **1995**, *43*, 667–674.
- (131) Bakermans, C.; Madsen, E. L. *Abstract*, American Society for Microbiology, Annual Meeting, Miami, FL, 1997; N-120; p 401.
- (132) Stein, J. L.; Marsh, T. L.; Wu, K. Y.; Shizuya, H.; DeLong, E. F. *J. Bacteriol.* **1996**, *178*, 591–599.

Received for review June 23, 1997. Revised manuscript received November 4, 1997. Accepted November 19, 1997.

ES970551Y