

C.S.L.
F.C.K. RECEIVED
J.O.H. 6 SEP 1951
ANSWERED

JOURNAL

OF THE

ASSOCIATION OF OFFICIAL AGRICULTURAL CHEMISTS

VOL. 34

AUGUST 15, 1951

No. 3

EDITORIAL BOARD

HENRY A. LEPPER, *General Chairman*

EDITORIAL COMMITTEE OF THE JOURNAL

PAUL A. CLIFFORD, *Chairman and Editor*

E. L. GRIFFIN

J. B. SMITH

F. H. WILEY

A. H. ROBERTSON

KATHARINE RONSAVILLE, *Assistant Editor*

Referee Reports

Contributed Papers

PUBLISHED QUARTERLY BY
THE ASSOCIATION OF OFFICIAL AGRICULTURAL CHEMISTS, INC.

Editorial and Advertising Office: Box 540, Benjamin Franklin Station, Washington 4, D.C.

Copyright, 1951, by the Association of Official Agricultural Chemists

Entered as second class matter at the post office at Menasha, Wisconsin, under the Act of August 24, 1912. Acceptance for mailing at special rate of postage provided for in the Act of February 28, 1915, embodied in paragraph 4, section 412 P. L. & R. authorized March 25, 1931. Issued quarterly in February, May, August, and November.

You will want this book

DIAGNOSTIC TECHNIQUES for SOILS and CROPS

Since the beginning of agricultural chemistry, one of the chief problems has been the determination of the nutrient needs of soils and crops. Tremendous progress has been made, and during recent decades of research by agricultural scientists working in the diagnostic field, many new methods have been devised to aid farmers in fertilizing their crops more effectively. In this book are to be found discussions of these diagnostic approaches with appraisals of their value and use.

The size?—7¼" x 10¼"—The binding?—durable green cloth—The contents?—332 pages of text and illustrations (8 chapters and historical introduction by eminent scientists, and the illustrations include 5 color plates, 36 halftones, and 26 drawings).

Specially priced at \$2.00 per copy, postpaid, this book may be purchased through

THE AMERICAN POTASH INSTITUTE

1155 16th St., N.W.

Washington 6, D.C.

WANTED

Back Numbers of This Journal

Volume X-No.1 (February, 1927)
Volume XI-No.2 (May, 1928)
Volume XIII-No.1 (February, 1930)
Volume XVII-No.1 (February, 1934)
Volume XVIII-No.2 (May, 1935)
Volume XIX-all four numbers
Volume XX-No.1 (February, 1937)
Volume XXI-No.4 (November, 1938)
Volume XXIV-all four numbers
Volume XXV-all four numbers
Volume XXVII-No.4 (November, 1944)
Volume 28-Nos. 1, 2 (February, May, 1945)
Volume 29-Nos. 1, 2 (February, May, 1946)

The Association desires to obtain as many copies as possible of these numbers, and for such as are in good condition the full subscription price will be paid.

We have the specified Journals, A.G.A.C., for sale.
(Circle number. you have available for sale.)

Name
Address
City Zone State

ACCURATE MOISTURE METHODS

*require properly designed
equipment*

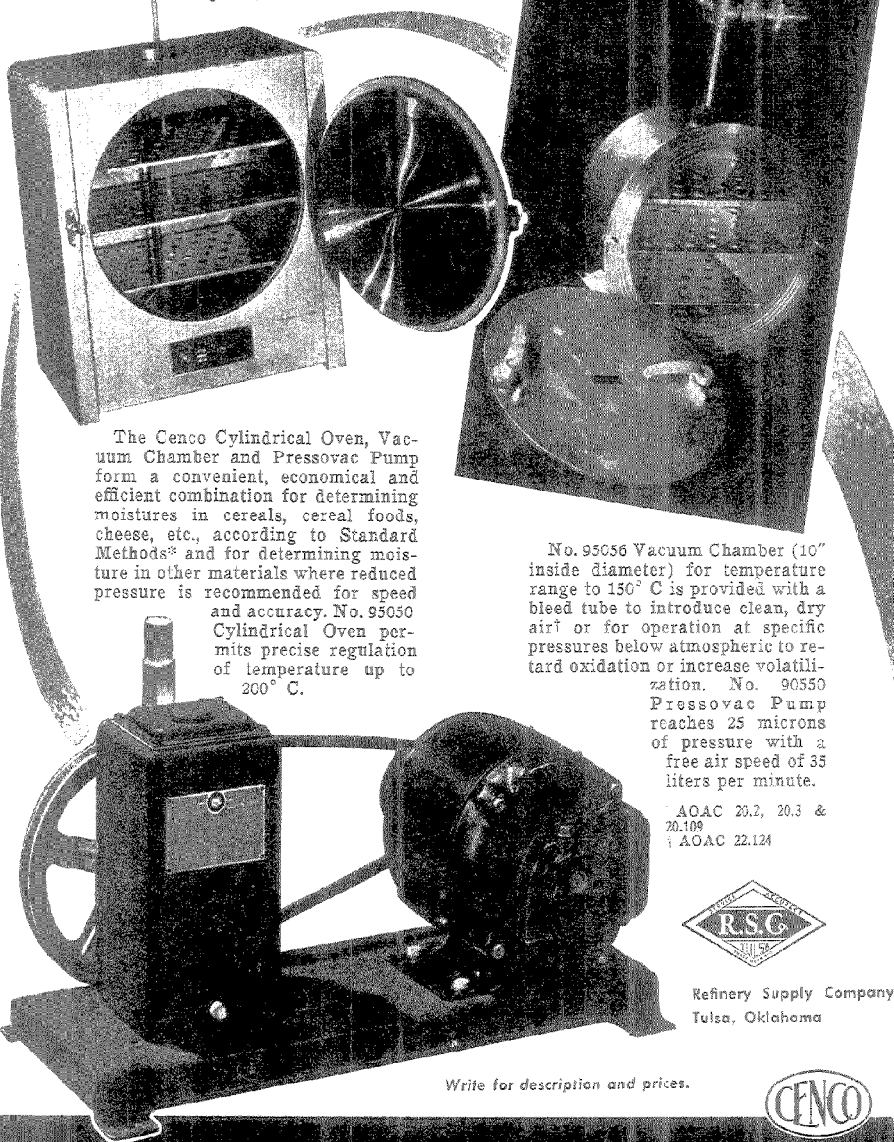

The Cenco Cylindrical Oven, Vacuum Chamber and Pressovac Pump form a convenient, economical and efficient combination for determining moistures in cereals, cereal foods, cheese, etc., according to Standard Methods* and for determining moisture in other materials where reduced pressure is recommended for speed and accuracy. No. 95050 Cylindrical Oven permits precise regulation of temperature up to 200° C.

No. 95056 Vacuum Chamber (10" inside diameter) for temperature range to 150° C is provided with a bleed tube to introduce clean, dry air† or for operation at specific pressures below atmospheric to retard oxidation or increase volatilization. No. 90550 Pressovac Pump reaches 25 microns of pressure with a free air speed of 35 liters per minute.

AOAC 20.2, 20.3 &
20.109
AOAC 22.124



Refinery Supply Company
Tulsa, Oklahoma

Write for description and prices.



CENTRAL SCIENTIFIC COMPANY

Scientific Apparatus • Instruments • Chemicals

1700 IRVING PARK ROAD, CHICAGO 13

NEW YORK BOSTON SAN FRANCISCO NEWARK LOS ANGELES TORONTO MONTREAL

VON CZOERNIG-ALBER

SEMIMICRO COMBUSTION FURNACE

Electric heating, for temperatures up to 750°C

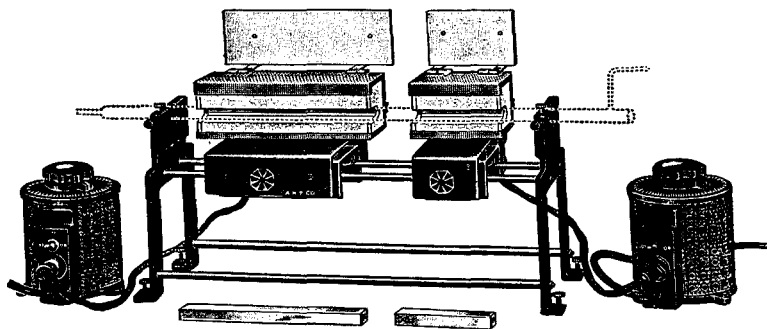

5682-L.

SEMIMICRO COMBUSTION FURNACE, Electric, von Czoernig-Alber, A.H.T. Co. Specification, complete with Sample Heater, for temperatures up to 750°C. For use with combustion tubes up to 16 mm outside diameter. For elementary quantitative organic semimicro analysis, including determinations for carbon and hydrogen, nitrogen by the Dumas method, halogens and sulfur by the catalytic procedure.

Provides uniform and constant temperatures within the ranges required for many types of semimicro tests simply by changing the position of the tube in the furnace, but the use of transformer or rheostat is suggested for critical work or when the temperature must be changed gradually.

The outside dimensions of the furnace body are 8 inches long X 3 inches deep X $2\frac{1}{16}$ inches high, with chamber 8 inches long X $1\frac{1}{4}$ inches deep X $\frac{3}{4}$ inch high. The hinged front is of transite and can be raised with unprotected fingers by wire handle. Mounted on an adjustable stand with leveling screws and adjustment for centering and clamping combustion tubes. Furnace body can be moved laterally, either to right or left, on tracks 18 inches long; also moved forward or backward [or approximately 2 inches.

Sample Heater is of the hinged front type. Heating chamber is $4\frac{1}{4}$ inches long X $1\frac{1}{4}$ inches deep X $\frac{3}{4}$ inch high. Furnished with heat deflector and Type 116 Variable Transformer to maintain the input at maximum safe operating voltage of 80 volts; power consumption 300 watts.

5682-L. Furnace, Semimicro Combustion, von Czoernig-Alber, Electric, with Hinged Front Sample Heater, A.H.T. Co. Specification, on adjustable stand, as above described. For use with semimicro tubes up to 16 mm outside diameter. Complete with two Variable Transformers, Type 116, two heat deflectors, two connecting cords with plugs and snap switch, and directions for use. For 115 volts, 50 or 60 cycles, a.c., only; total power consumption 645 watts 232.9-5

5682-N. Ditto, Furnace only, without Sample Heater or Transformers. Complete with heat deflector, 5 ft. of cord with snap switch, plugs and directions for use. For 115 volts, a.c. or d.c. Power consumption 345 watts 115.75

NOTE—Two types of Furnace Drive are available for use with above Furnaces. *Information sent upon request.*

ARTHUR H. THOMAS COMPANY

RETA/L-WHOLESALE-EXPORT

LABORATORY APPARATUS AND REAGENTS

WEST WASHINGTON SQUARE

PHILADELPHIA 5, PA., U.S.A.

CABLE ADDRESS, "BALANCE" PHILADELPHIA

JOURNAL

OF THE

ASSOCIATION OF OFFICIAL AGRICULTURAL CHEMISTS

Vol. 34

AUGUST, 1951

No. 3

CONTENTS

TUESDAY-MORNING SESSION

	Page
Report on Decomposition and Filth in Foods (Chemical Indices). By W. I. Patterson	497
Report on Uric Acid in Fruit Products. By Doris H. Tilden	498
Report on Decomposition of Fruits and Fruit Products. By W. O. Winkler	506
Report on Galacturonic Acid in Strawberry Juice. By Paul A. Mills	513
Report on Uric Acid in Cereal Products. By Helen C. Barry	520
Report on Succinic Acid in Tomato Products. By Halver C. Van Dame	522
Report on Metals, Other Elements, and Residues in Foods. By H. J. Wichmann	524
Report on Mercury. By A. K. Klein	529
Report on Parathion. By P. A. Clifford	533
Report on Sodium Fluoroacetate (1080). By L. L. Ramsey	536
Report on Methoxychlor. By Frieda Kunz and E. Laug	537
Report on Enzymes. By J. W. Cook	539
Report on Hydrocyanic Glucosides. By W. O. Winkler	541
Report on Feeding Stuffs. By M. P. Etheredge	548
Report on Iodine in Mineral Mixed Feeds. By A. T. Perkins	549
Report on Fat in Fish Meal. By M. E. Stansby	549
Report on Microscopic Analysis. By J. A. Shrader	554
Report on Crude Fiber. By William L. Hunter	557
Report on Crude Fat or Ether Extract. By Harold H. Hoffman	558
Report on Sulfa Drugs in Feeds. By Richard T. Merwin	559
Report on Mineral Constituents of Mineral Feeds. By J. L. St. John	563
Report on Tankage (Hide, Hoof, Horn, and Hair Content). By A. T. Perkins	564
Report on Vegetable Drugs and Their Derivatives. By Paul S. Jorgensen	564
Report on Rutin in Tablets. By Arthur Turner, Jr	565
Report on Theobromine and Phenobarbital. By Daniel Banas	566
Report on Synthetic Drugs. By F. C. Sinton	567
Report on Synthetic Estrogens. By Daniel Banas	569
Report on Carbromal in Mixtures. By Rupert Hyatt	570
Report on Spectrophotometric Methods. By Jonas Carol	572
Report on Propylthiouracil. By Gordon Smith	576
Report on Butacaine Sulfate. By Llewellyn H. Welsh	577
Report on Sulfanilamide Derivatives. By H. W. Conroy	578
Report on Miscellaneous Drugs. By I. Schurman	581
Report on Estrone and Estradiol. By Edward O. Haenni	581
Report on Preservatives and Bacteriostatic Agents in Ampul Solutions. By Charles N. Jones	585
Report on Glycols and Related Products. By Harry Isacoff	586
Report on Soils and Liming Materials. By W. H. MacIntire	586
Report on Hydrogen-Ion Concentration of Soils. By Lannes E. Davis	588
Report on Exchangeable Potassium in Soils. By A. Mehlich, R. F. Reitemeier, and D. D. Mason	589
Report on Liming Materials and Exchangeable Hydrogen in Soils. (By W. M. Shaw	595
Report on Fluorine. By W. H. MacIntire, L. J. Hardin, and L. S. Jones	597
Report on Spectrographic Methods. By W. T. Mathis	604

TUESDAY-AFTERNOON SESSION

Report on Standardization of Microchemical Methods. By C. O. Willits and C. L. Ogg	607
Report on Fertilizers. By F. W. Quackenbush	620
Report on Sampling Fertilizers. By H. R. Allen	620
Report on Phosphoric Acid. By K. D. Jacob <i>et al.</i>	624
Report on Free Water in Fertilizers. By W. H. Hill, J. H. Caro, and R. Kumagai	641
Report on Nitrogen in Fertilizers. By H. A. Davis	653
Report on Potash. By O. W. Ford	660
Report on Sulfur in Mixed Fertilizers. By Gordon Hart and N. J. Halbrook	666
Report on Economic Poisons. By J. J. T. Graham	667
Report on Rodenticides. By J. B. LaClair	670
Report on Chlordane and Toxaphene. By Thomas H. Harris	672
Report on Herbicides. By A. B. Heagy	674
Report on Quaternary Ammonium Compounds. By R. L. Caswell	675
Report on Organic Thiocyanates. By Herbert A. Rooney	677
Report on Phenolic Disinfectants. By W. A. Affens	681
Report on Parathion. By Fred I. Edwards, Jr	686
Report on Benzene Hexachloride. By C. V. Bowen	689
Report on Disinfectants. By L. S. Stuart	690
Report on Plants. By E. J. Miller	691
Report on Zinc in Plants. By Eunice J. Heinen and Erwin J. Benne	692
Report on Starch in Plants. By Carroll L. Hoffpauir	698
Report on Sugars in Plants. By Kenneth T. Williams and Arthur Bevenue	700
Report on Cobalt and Copper in Plants. By Kenneth C. Beeson	702
Announcements	702

CONTRIBUTED PAPERS

The Spectrophotometric Assay of Complex Antihistimic Preparations. By Daniel Banes	703
Some Modifications in the Ortho-Nitroresol Method for the Determination of Cobalt. By Richard L. Gregory, Clayton J. Morris, and Gordon H. Ellis	710
Rapid Assay for Nitroglycerine Tablets. By James H. Cannon and Richard F. Heuermann	716
Effect of Neutralization of Cream in the Manufacture of Butter on Water-Insoluble Fatty Acids and Butyric Acid. By Fred Hillig, S. W. Ahlmann, and R. C. Jordan	720
Micro-Method for the Determination of Vanillin and Ethyl Vanillin in Vanilla Extracts. By R. M. Way and W. R. Gailey	726
Population Studies of <i>Micrococcus Pyogenes</i> Variety <i>Aureas</i> 209. By B. Wesley Catlin and A. J. Salle	731
Spectrophotometric Quantitative Determination of Methanol in Distilled Spirits. By George F. Beyer	745
Technique for Infrared Analysis of Solids Insoluble in Nonpolar Solvents. By M. Dolinsky	748

NOTES

Chromatographic Separation and Determination of Some Organic Thyocyanates in Insecticide Products. By Boyd L. Samuel	764
Determination of Nitrogen in Calcium Ammonium Nitrate by Formaldehyde Titration. By Frances L. Bonner and Ernest A. Epps, Jr	766

BOOK REVIEWS

Leaf Analysis. By Erwin J. Benne	767
Wines of the World. By Peter Valaer	767
Check List on Grapes and Wine, 1938-1948. By J. W. Sale	768
Soybeans and Soybean Products. By V. E. Munsey	768
Bibliography of Standard, Tentative and Recommended or Recognized Methods of Analysis. By A. H. Robertson	769
Industrial Oil and Fat Products. By J. Fitelson	770

ASSOCIATION OF OFFICIAL AGRICULTURAL CHEMISTS- OFFICERS 1951

President, H. A. HALVORSON, Department of Agriculture, Dairy and Food, St. Paul, Minn.

Secretary-Treasurer Emeritus, W. W. SKINNER, Kensington, Md.

Secretary-Treasurer, HENRY A. LEPPER, U. S. Food and Drug Administration, Washington 25, D. C.

Additional Members of Executive Committee, WM. F. REINDOLLAR, Baltimore, Md.; H. J. FISHER, New Haven, Conn.; E. L. GRIFFIN, Washington, D. C.; and W. A. QUEEN, Washington, D. C.

Committee on Recommendations of Referees, W. F. REINDOLLAR (Bureau of Chemistry, State Department of Health, Baltimore 18, Md.), *Chairman*.

Subcommittee A: E. L. GRIFFIN (1952), (Production and Marketing Administration, Washington, D. C.), *Chairman*; J. B. SMITH (1954); and C. W. MARSHALL (1956).

Subcommittee B: F. H. WILEY (1952), (Food and Drug Administration, Washington 25, D. C.), *Chairman*; HARRY J. FISHER (1954); and G. R. CLARK (1956).

Subcommittee C: P. A. CLIFFORD (1952), (Food and Drug Administration, Washington 25, D. C.), *Chairman*; A. H. ROBERTSON (1954); and S. ALFEND (1956).

Subcommittee D: J. WALTER SALE (1952), (Food and Drug Administration, Washington, D. C.), *Chairman*; FLOYD ROBERTS (1954); and KENNETH L. MILSTEAD (1956).

INFORMATION FOR SUBSCRIBERS AND CONTRIBUTORS

The Journal of the Association of Official Agricultural Chemists is issued quarterly in February, May, August, and November, the four numbers comprising the annual volume. Each volume will contain approximately 600 pages. Subscriptions are taken by the volume, at \$7.50 prepaid in North America and U. S. possessions, and \$8.00 to all foreign countries.

Reprints will be furnished at cost to contributors of articles printed in *The Journal*. A table showing cost, with an order slip, is sent by the printer with proof.

Manuscripts should be typewritten, double-spaced, carefully revised before submission, and the original and one carbon submitted to the Association of Official Agricultural Chemists, Box 540, Benjamin Franklin Station, Washington 4, D. C.

Claim for copies lost in the mails will not be allowed unless received within thirty days of the date of issue. Claimants must state that the publication was not delivered at their recorded address. Notice of change of address must be forwarded at least one week in advance of issue; otherwise publishers will not be responsible for loss. To foreign subscribers, replacement of copies of *The Journal* lost in transit cannot be made without charge, on account of uncertain mailing conditions abroad.

ANNOUNCEMENTS

SIXTY-FIFTH ANNUAL MEETING

The 65th Annual Meeting of the Association of Official Agricultural Chemists will be held October 1 to 3, 1951, at the Shoreham Hotel, 2500 Calvert St., N.W., Washington 8, D. C.

TUESDAY-MORNING SESSION

REPORT ON DECOMPOSITION AND FILTH IN FOODS (CHEMICAL INDICES)

By W. I. PATTERSON (Food and Drug Administration, Federal Security Agency, Washington 25, D. C.), *Referee*

The relative lack of new and startling discoveries in this field is a poor measure of the quantity of work which was done during the past year. In this difficult chemical field, for every successful attempt to find a useful test, there will be many unsuccessful tries; and most of these failures are not deemed worthy of presentation. Again, most of the recommendations for further study of a method were carried out; but in some cases the accumulated data did not seem to merit presentation at this meeting.

Water-insoluble acids (WIA) and butyric acid are now in regulatory use to detect the use of rotten cream in butter manufacture. Indole is tentatively accepted for the detection of decomposed shrimp. When analysis of additional authentic packs of fish is completed the regulatory use of volatile acids, succinic acid, and water insoluble acids (WIA) will likely be possible on one or more fishery products.

RECOMMENDATIONS

The Referee concurs in the recommendations of the Associate Referees for Decomposition and Filth in Foods (Chemical Indices), as follows:

A. Fruit and Fruit Products.

(1) That the study of galacturonic acid as a possible measure of decomposition in apples and strawberries be continued.

(2) That the proposed methods for galacturonic acid be studied collaboratively.

(3) That search be made for other criteria of decomposition.

(4) That the proposed method for catecholase activity in pineapple be studied collaboratively.

B. Tomatoes.

(1) That the study of succinic and other acids as possible criteria of rot be continued.

C. Filth in Foods-Chemicals Indices.

(1) That the study of uric acid as a possible criterion of filth in cereal products and nuts be continued.

(2) That the search for indicators of animal fecal matter in foods be pursued.

* For report of Subcommittee C and action of the Association, see *This Journal*, 34, 49 (1951).

REPORT ON URIC ACID IN FRUIT PRODUCTS

By DORIS H. TILDEN (U. S. Food and Drug Administration,
Federal Security Agency, San Francisco, Calif.),
Associate Referee

The search for an adequate, reliable, and consistent method of separating and estimating minute amounts of uric acid occurring in fruit products as a result of the use of insect contaminated raw stock, has extended almost fruitlessly over many years. However, the abundant reports, in recent scientific literature, of instances in which effective use is made of paper partition chromatography in separating, identifying, and quantitatively estimating various biological substances, gave rise to the hope of adapting such a technique successfully to the separation and determination of small amounts of uric acid in fruit products.

The work of Vischer and Chargaff (6) on purines and pyrimidines, using paper partition chromatography, indicated a possible line of approach to the problem, but following their procedure it became evident that uric acid (2, 6, 8 trioxypurine) would not respond chromatographically to the same partitioning reactions as even its closest chemical relative in the purine family. Most of the solvent systems used by Vischer and Chargaff, as well as several other systems, were tried with pure uric acid in acid and in alkaline solutions, but no migration occurred. Finally a system comprised of phenol, acetic acid and water,¹ with an atmosphere of acetic acid, was used. This was found to be effective in moving uric acid up a paper strip, from a spot of solution made alkaline with lithium carbonate. The location of the material after partitioning was made visible by producing a mercury complex and developing it with ammonium sulfide. As described in Vischer and Chargaff's work, the developed chromatogram became a control and guide in locating the area of deposited uric acid on an undeveloped, completed chromatogram. The portion of paper bearing the separated uric acid was then cut away, and the uric acid removed with a suitable solvent, for verification and quantitative estimation by means of readings obtained on the solution, using the Beckman spectrophotometer in the ultra violet range.

EXPERIMENTAL

A study was made of the extinction values in the ultra violet range of standard quantities of pure uric acid in 0.1 *N* sulfuric acid. A standard curve was developed by plotting transmission against concentration. Uric acid was partitioned on paper and treated in the same manner. Similarly, uric acid was added to a fruit syrup, partitioned and the absorption curve developed. Curves were found to be identical.

¹ The use of this solvent system was suggested by Dr. McCready and associates, of the Western Regional Research Laboratory, Albany, California.

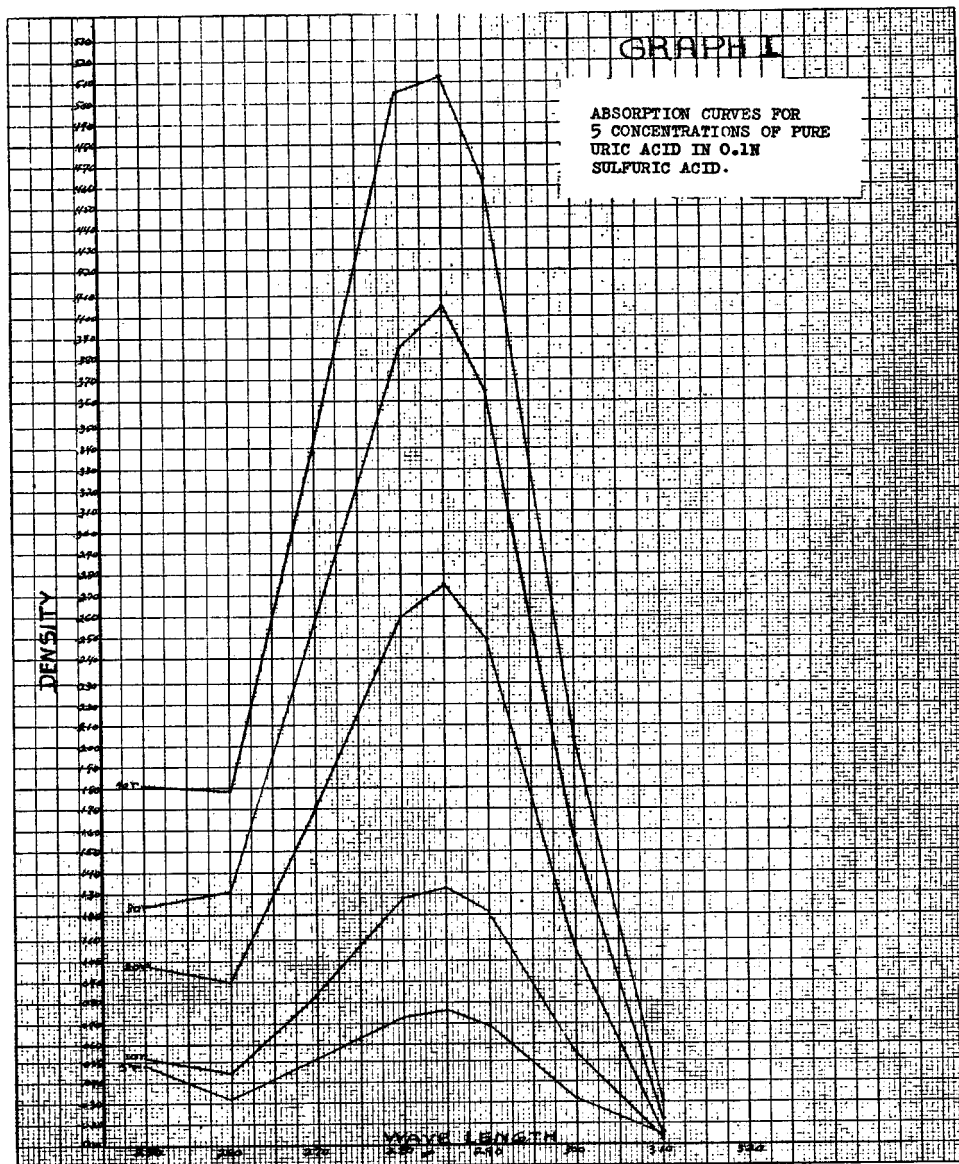

GRAPH I.—Absorption curves for 5 concentrations of pure uric acid in 0.1 N sulfuric acid.

Uric Acid in 0.1 N Sulfuric Acid.

A solution of pure crystalline uric acid was prepared (Folin (3)) of such strength that 0.01 ml contained 10 gamma (micrograms) of uric acid. Aliquots of this solution were measured into small beakers, using 0.005 ml; 0.01; 0.02; 0.03; and 0.04 ml portions, to which exactly 5 ml of 0.1 N sulfuric acid were added. The transmission and density points of these solutions were determined by means of the Beckman spectrophotometer, using 1 cm. quartz cells and ultra violet light, at wave lengths of 250 to

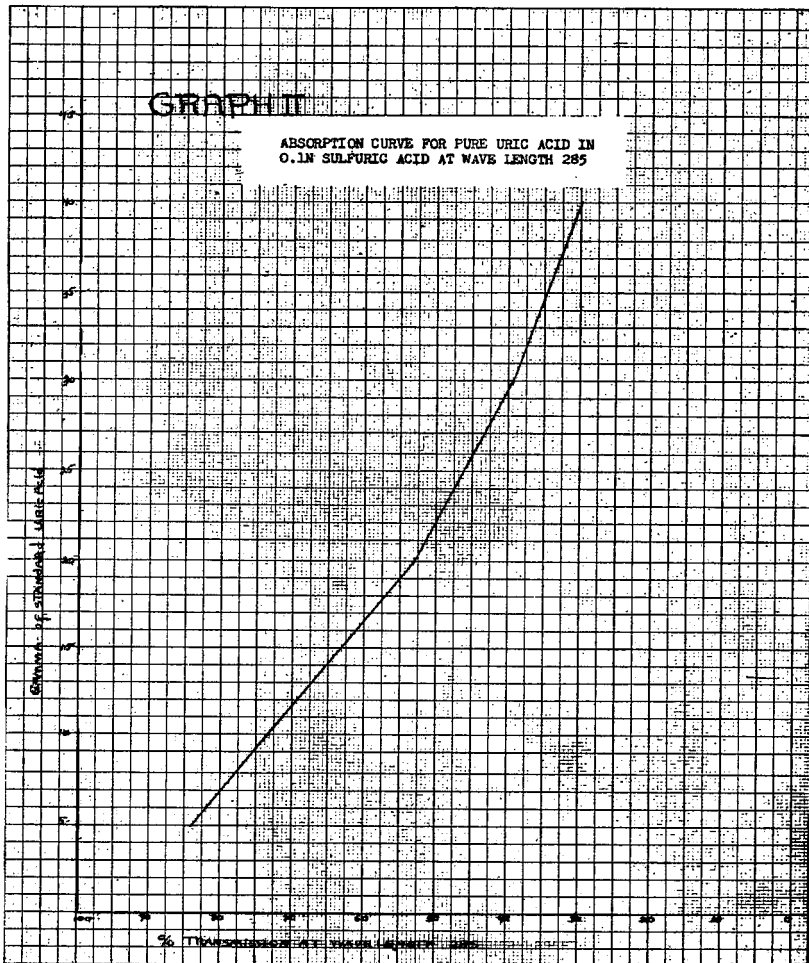

GRAPH 2.—Standard curve for pure uric acid in 0.1 N sulfuric acid at wave length 285.

310, at 5 to 10 $m\mu$ intervals. Curves obtained for five quantities of standard uric acid in 0.1 *N* sulfuric acid are shown on Graph 1, where wave length is plotted against density. The absorption points of these quantities, at wave length 285, are shown on Graph 2 where transmittance is plotted against gamma of uric acid.

Uric Acid Partitioned on Paper.

On a sheet of Whatman #1 filter paper about fifteen inches high lanes one and one-half inches wide were ruled off and a light line was drawn across the lower edge of the paper to designate the starting point. In a marked circular space on this line (in the center of each lane) was deposited an aliquot of the standard solution of uric acid corresponding to 5, 10, 20, 30, and 40 gamma of uric acid. Triplicate spots were made for each concentration. One lane was left blank. The paper sheet was suspended in a developing tank which contained the partitioning solvent of phenol, acetic acid, and water, to a depth of about one-half inch, together with a small beaker of glacial acetic acid. The latter provides an atmosphere of acetic acid. The paper dipped into the solvent about one-eighth of an inch. Partitioning was continued for 16 hours. At the end of this time the chromatogram was removed, aired, and dried until most of the phenol and acetic acid were gone. One lane of each quantity of uric acid deposited was cut from the sheet and sprayed with a mercuric nitrate-nitric acid reagent. The mercury complex was made visible by washing the sprayed paper strip in a water bath through which a slow stream of water circulated. Small paper strips also sprayed with mercuric nitrate and put into the same bath, served as controls for adequacy of washing. When the strips failed to darken on treatment with ammonium sulfide solution, washing was considered complete. The washed chromatograms were treated with ammonium sulfide solution. Well-defined black spots indicated the location of uric acid.

Completed chromatograms, upon which the uric acid-mercury complex was not developed, were dried in circulating warm air until all traces of phenol and acetic acid were removed.

By use of the developed mercury complex spots on the guide strip the position of uric acid was located on the untreated strips. This area was marked with a pencil, allowing ample space on all sides of the spot. The portion was then cut from the paper and placed in a small beaker. A similar portion was cut from the blank lane and treated in the same manner as the standards. The uric acid was dissolved from the paper in exactly 5 ml. of 0.1 *N* sulfuric acid, filtered through a small, dry, rapid filter paper and the absorption in the ultra violet was determined as described above. Results of the recovery of uric acid from a chromatogram of 0.02 ml. (20 gamma) of the standard solution are shown in Graph 3.

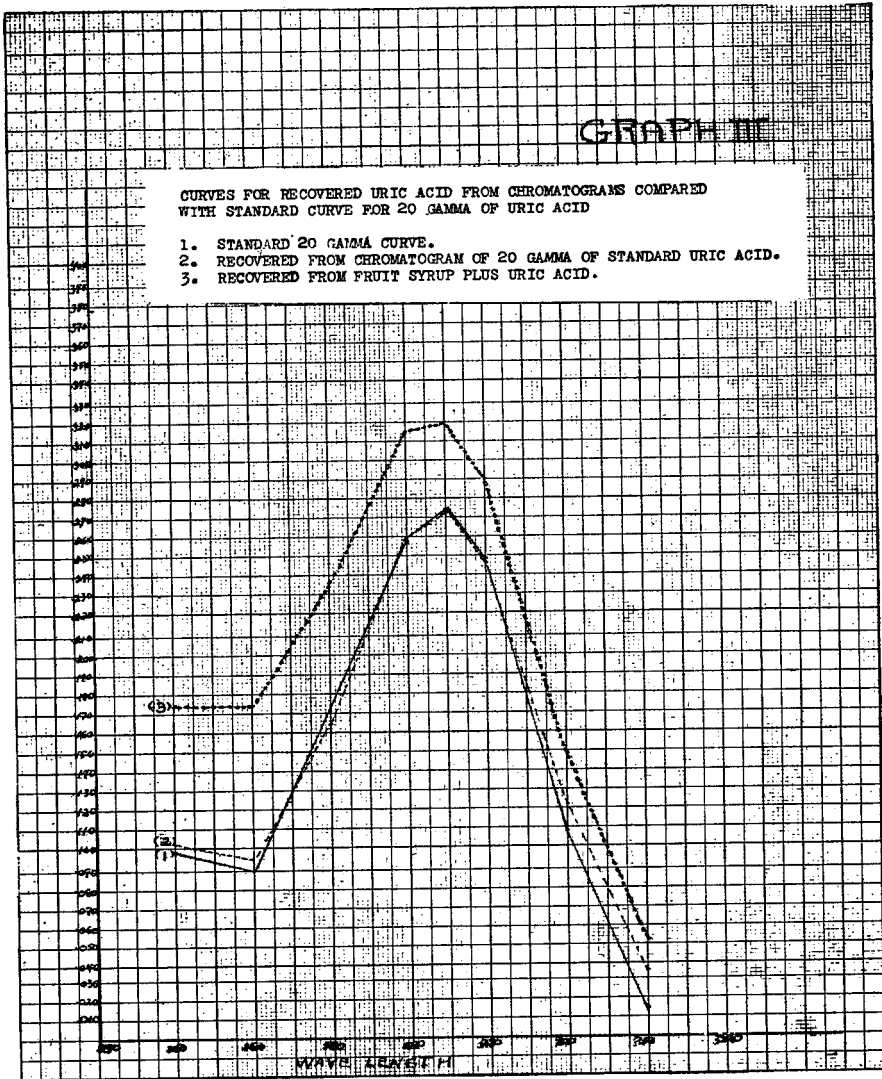

GRAPH 3.—Curves for recovered uric acid from chromatograms compared with standard curve for 20 gamma of uric acid. 1. Standard 20 gamma curve. 2. Recovered from chromatogram of 20 gamma of standard uric acid. 3. Recovered from fruit syrup plus uric acid.

Uric Acid Recovered from Fruit Syrup.

To a fruit syrup with a soluble solids content of 25 per cent, a quantity of pure uric acid was added, such that 0.01 ml contained 10 gamma of uric acid. Pectinous material was precipitated with alcohol from 100 ml. of this solution and, after standing about two hours, was filtered off. Alcohol was completely removed from the filtrate by repeatedly adding water and evaporating. The final solution was made back to 100 ml volume, thus adjusting the soluble solids content to approximately the same as the original material. A portion of this solution was made distinctly alkaline with dry lithium carbonate and filtered. Aliquots were spotted directly on paper, partitioned and treated in the manner described above.

Well-formed and reproducible spots were obtained. These were in the same position on the paper strips as those produced by standard solutions of uric acid. The mercury complex produced by aliquots containing as little as five gamma of added uric acid could be detected. Partitioned material which shows all the characteristic spectrophotometric points of a standard uric acid curve, has been removed from chromatograms of larger amounts of such a sample solution.

For concentrating small amounts of uric acid added to a fruit syrup, a procedure based on that of Geren *et al.* (2) has been tried, using charcoal to adsorb the uric acid, and a hot lithium carbonate solution for eluting it. This method shows possibilities, but many details need to be improved. For one, filtration is extremely slow. Preliminary runs showed, however, that uric acid added in the proportion of 10 gamma per 0.01 ml can be recovered from a 22 per cent prune syrup, and that 0.10 ml or more of the final solution can be built up satisfactorily on a paper strip. Recovery points obtained on a fruit syrup using this procedure are shown on Graph 3. The quantitative aspect of this method has not been investigated as yet.

DISCUSSION

In establishing the absorption points of standard uric acid, for the curve represented on Graph 1, it was found that identical readings for transmission and density were not obtained on duplicate aliquots. This might be accounted for by the difficulty in reading the micro pipette precisely, and this factor must be taken into account when evaluating the results of recovery experiments.

At present, calculation of the R_f figure for the uric acid-mercury complex has not seemed of particular interest, although it shows a consistent tendency to be between 0.45 and 0.50 depending on length of time of "run." Unless other substances in the sample produce a mercury complex which might be confused with that of uric acid, the figure is of little value in these experiments.

Work with insect excreta pellets and with chicken excrement indicates that protein degradation products which show a tendency to migrate on paper, from acid solutions, apparently do not do so from solutions made alkaline with lithium carbonate under the conditions of the above described experiments. Only one mercury complex spot, and that in the position for uric acid, has been evident on chromatograms developed from lithium carbonate extracts of insect excreta pellets and of chicken manure.

The presence of pectins and the concentration of soluble solids in fruit syrups are two of the chief factors adversely affecting partition on a paper strip. The pectins may be removed by precipitation with alcohol but building up a spot of such a filtrate is of course accompanied by a corresponding buildup of soluble solids which, if nothing else, mechanically prevents separation of the desired constituent from the original material.

The quantities of uric acid used in experimental work have been in the neighborhood of 10 gamma per 0.01 ml, which in itself seems to be a very small amount. If, however, this were calculated back to the original syrup, it would mean there is present in 100 ml about 100 milligrams of uric acid as such. This, again calculated back to ingoing raw stock, would amount to a far greater degree of insect contamination than could be expected even in very filthy material. Beck (1) points out that for a method to be effective in detecting the use of raw stock containing as many as 400 insect excreta pellets on each 70 prunes in the manufacture of a prune syrup, it must be capable of detecting differences of 0.2 gamma of uric acid per ml, in the range of 0 to 2 gamma per ml.

In using paper partition chromatography, from the nature of the technique itself, we are limited to the deposition of small volumes of solution. Thus, uric acid which might be present in minute amounts must necessarily be concentrated in some manner. Concentration of the filtrate after an alcohol precipitation, whether accomplished by building up a spot on the paper strip or by removing water otherwise, results in blocking the action of the separating solvent. It may be possible to combine the two procedures already mentioned, that is, remove the pectins with alcohol and then concentrate the uric acid in the alcohol-free filtrate by adsorbing it on charcoal, and eluting it with a small volume of hot lithium carbonate solution. This material, with sugars removed, can be spotted directly on paper and the spot built up to contain a relatively significant amount of uric acid.

Early in the course of experimental work, an attempt was made to adapt Duggan's (2) extraction procedure for uric acid in eggs to fruit concentrates, but it was unsuccessful largely because of a carry-over of substances by or with the quinoline, which interfered with formation of the mercury-uric acid complex.

The presence of any trace of phenol remaining on completed chromatograms of uric acid has caused erroneous and erratic results when reading the strip solution in ultra violet light. The present procedure of air drying is time consuming and often unsatisfactory because of the tenaciousness with which the separating solvent adheres to the filter paper. Better and quicker means of obtaining a phenol-free solution for spectrophotometric examination are being studied.

In routine work, it may not always be necessary to make spectrophotometric determinations to evaluate uric acid, since production of the mercury complex indicates its presence, and the relative quantity of uric acid may be estimated by the size and intensity of the black spot.

SUMMARY

A procedure based on the use of paper partition chromatography is described, by which uric acid in minute amounts has been recovered from known standard solutions and, in somewhat larger amounts, has been recovered from fruit syrups to which it was added. Development of a mercury complex of uric acid, after chromatographing, can be used as a sort-out procedure for uric acid and in locating the position of the acid on a paper strip following partition in a phenol-acetic acid-water solvent system. It seems possible to develop the procedure into a fairly satisfactory method for isolating and determining uric acid as it may occur in fruit syrups made from insect infested raw stock.

RECOMMENDATIONS*

It is recommended-

That the study of means for concentrating and separating minute amounts of uric acid in the presence of interfering fruit constituents be continued.

That the use of paper partition chromatography be further studied in connection with the isolation and determination of small amounts of uric acid in fruit products.

REFERENCES

- (1) BECK, J. V., Unpublished reports on "Uric Acid in Dried Fruit Products," 1942 and 1943.
- (2) DUGGAN, R. E., "The Estimation of Chicken Manure in Egg Products from Their Uric Acid Content," *This Journal*, 29, 76 (1946).
- (3) FOLIN OTTO, "An Improved Method for the Determination of Uric Acid in Blood," *J. Biol. Chem.*, 86, 179 (1930).
- (4) GEREN, WM., BENDICH, A., BODANSKY, O., and BROWN, G. B., "The Fate of Uric Acid in Man," *Ibid.*, 183, 21 (1950).
- (5) VISCHER, ERNST, and CHARGAFF, ERWIN, "The Separations and Characteristics of Purines in Minute Amounts of Nucleic Acid Hydrolysates," *Ibid.*, 168, 781 (1947).
- (6) — — —, "The Separation and Quantitative Estimation of Purines and Pyrimidines in Minute Amounts," *Ibid.*, 176, 703 (1948).

* For report of Subcommittee C and action of the Association. see *This Journal*, 34, 49 (1951).

REPORT ON DECOMPOSITION OF FRUITS AND FRUIT PRODUCTS

GALACTURONIC ACID

By W. O. WINKLER (U. S. Food and Drug Administration, Federal Security Agency, Washington, D. C.), *Associate Referee*

The work in 1948 and 1949 was directed mainly toward the detection of deterioration (particularly blackheart) in samples of fresh frozen pineapple. This year's work was of broader application and consisted of a study of methods for determination of galacturonic acid in fruit and fruit juices. This acid was found by Harris (1) to be a valuable criterion of decomposition. A number of procedures have been tried for the quantitative determination of this acid in fruit products. These included (1) chromatographic separation followed by titration or oxidation, (2) separation of acids by lead precipitation and determination by oxidation or with naphthoresorcinol, and (3) separation of acids by ion exchange resins and determination by oxidation or with naphthoresorcinol.

A fairly extensive study was made of chromatographic techniques on silica gel columns using various organic solvents, particularly chloroform and butanol as the mobile phase. Dilute sulfuric acid and glycerol-water mixtures were used as the immobile phase. The polybasic acids found in fruit are only slightly soluble in many organic solvents. Butanol, isobutanol, and tertiary amyl alcohol are among the best solvents not miscible with water. Mixtures of butanol and chloroform containing up to 50 and even 60 per cent of butanol were necessary to move the acids at a sufficient rate down the column with a sample of sufficient size for the determination. This high percentage of butanol was found to carry along small amounts of sulfuric acid in the eluate so that the "endpoint" at which the principal organic acids have been removed was imperceptible. The use of a 50 or 60 per cent glycerol solution on the column was tried with fair success in some cases but considerable "tailing out" of the acids was experienced in a large portion of the samples. The galacturonic acid remains on the column in the chromatographic separation and therefore any other acid residue affects the value obtained by titration. There are two drawbacks to the method; the first is its insufficient sensitivity; the second is the occurrence of some high erratic blank values obtained on solutions of pure malic or citric acids, which could not be explained. For these reasons, sufficient credence could not be placed on results with unknown samples.

The oxidation methods employing basic iodine solution (procedure as given in *Journal of Research, N. B. S.*, **24,246** (1940)) was found to be unduly influenced by natural coloring matters and traces of sugars. The lead precipitation methods permitted the loss of considerable quantities of the acids in the filtrate, including galacturonic, and the precipitate was contaminated with sizable amounts of sugars.

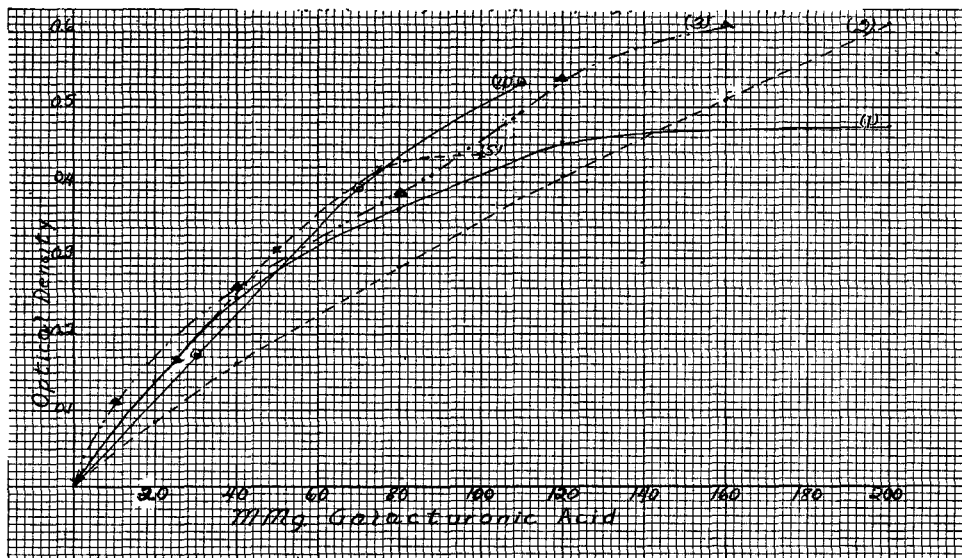

FIG. I.-Experimental curves, showing effect of different grades of naphthoresorcinol

- (1) Curve on Impure Naphthoresorcinol Batch I 50 mg Heating 90 minutes 0.75 ml alcohol.
 (2) ----- Curve using 50 mg Purified Naphthoresorcinol Heating 70 minutes, 1 ml. 75% alcohol.
 (3) $\triangle-\triangle-\triangle$ Curve Using 50 mg Impure Naphthoresorcinol Batch (2) 2 ml. 50% Alcohol.
 (4) $\circ-\circ-\circ$ Curve Using 25 mg Impure Naphthoresorcinol Batch (3) Heating 120 min. 2 ml $37\frac{1}{2}\%$ Alcohol.
 (5) $\times-\times-\times$ Curve Using 25 mg Impure Naphthoresorcinol Batch (3) Heating 180 min. 2 ml $37\frac{1}{2}\%$ Alcohol.

The most satisfactory procedure found for isolating the acids was by the use of ion exchange resins. By passing the partially clarified solutions first through a good cation exchange resin (Duolite C-3) and then through a good anion exchange resin, the acids were completely absorbed. Amberlite IRA 400 was the most satisfactory anion exchange resin tried in that it adsorbed less plant color and gave the lowest blank of the resins tried. The organic acids were replaced on the column by hydrochloric acid.

The most satisfactory method for the determination of the galacturonic acid in the mixed acids still seems to be by use of naphthoresorcinol in hydrochloric acid solution. If the reaction is carried out at 50°C ., the reagent is quite specific for the uronic acids and is very sensitive. There are, however, a number of disadvantages connected with the use of the reagent. Two of these are its high cost and the difficulty of obtaining and

keeping the reagent in a high state of purity. The reagent is easily oxidized or otherwise decomposed and most commercial samples are found to be quite impure. While the reagent can be purified, this always entails a rather heavy loss of material.

Some study of the various conditions affecting the reaction has been made; these included differences in time of reaction, composition of solution, and the purity of the reagent. The curves from some of these experiments are shown in Figure 1.

A study of the curves tends to show that the impurities in the reagent react with the derivative (probably a furfural derivative) of the galacturonic acid formed in the reaction more rapidly than the naphthoresorcinol in pure form. This is indicated by the higher slope of the curve from the more impure forms of reagent in the lower regions of the curve. The curves using the unpurified reagent tend to break or drop in the region of the larger quantities of the acid, especially when larger amounts (50 mg) of reagent are used.

The curve using the purified reagent, while not as steep in slope at the lower end as the unpurified ones, still does not break even up to 200 micrograms of the acid. The effective limit of the curve has generally been thought to be about 100 micrograms. A two hour reaction time using the purified naphthoresorcinol will be tried and should give a somewhat steeper curve. Based on the work so far, the accompanying method is proposed for use in the determination of galacturonic acid in fruits or juices.

GALACTURONIC ACID IN FRUITS AND FRUIT JUICES

APPARATUS

(a) Two glass tubes 22-25 mm *a.D.* X200 mm long containing columns of ion exchange resins with S shaped outlet tube. The ion exchange tubes are shown graphically in Fig. 2.

(b) A spectrophotometer with cells for reading in visible range (580 $m\mu$). A neutral wedge photometer with a filter isolating a narrow band of the spectrum centered at 580 $m\mu$ can be used instead of the spectrophotometer.

REAGENTS

(a) *Anion exchange resin.*-Amberlite IRA-400 or Duolite A-4 (preferably the first).

(b) *Cation exchange resin.*-Duolite C-3.

(c) *Naphthoresorcinol.*-Prepare a soln of the purified solid (see Note 1) containing 50 mg per ml in 75% alcohol.

(d) *Malic or citric acid.*-Prepare a 0.5% soln of malic or citric acid in water (depending on which is principal acid in the fruit being examined).

(e) *Standard galacturonic acid.*-A soln containing 20 mg of pure galacturonic acid (Note 2) and 1 g of malic acid (or citric) in 200 ml of soln.

(f) *Ethyl ether.*-A. C. S. grade, peroxide-free (Note 3).

NOTE I-To purify the reagent dissolve 3.5 g in 100 ml of hot water, add just enough sodium hydrosulfite to remove reddish coloration (few crystals), and 0.3 g of norite. Filter on a rapid filter into Erlenmeyer, add 7 g of solid sodium chloride to filtrate and dissolve. If more reddish color has developed, add sufficient solid

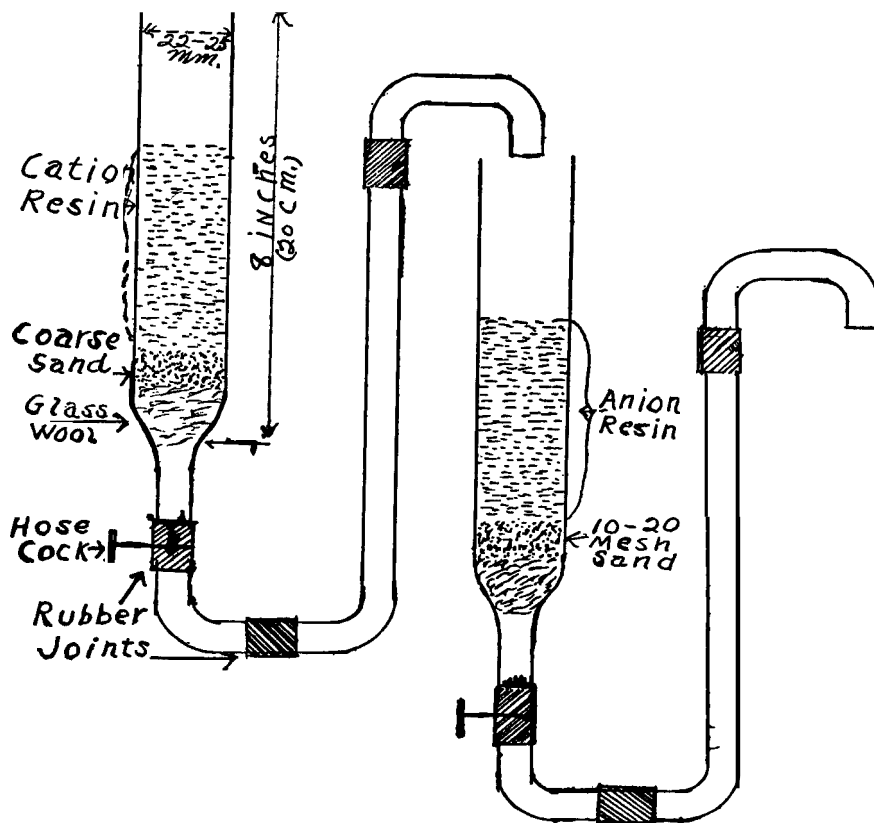

FIG. 2.-Ion exchange tubes

sodium hydrosulfite to remove it, stopper flask tightly, and let stand 24 hours in refrigerator at 5°C. Filter off crystalline precipitate on Buchner funnel, using portion of filtrate to transfer precipitate to funnel. Wash once with a little cold 7% NaCl soln. Dry crystals in vacuum desiccator over cone. H₂SO₄.

NOTE 2-If pure galacturonic acid is not available, the crude acid or its salts can be purified by precipitating the acid as the calcium salt, removing the calcium on a cation exchange column, concentrating the filtrate under vacuum to a syrup, dissolving the syrup in hot methyl alcohol, and cooling to 5-10°C.

NOTE 3-Test the ether with a fresh 10% soln of KI by shaking 2 ml of the soln with 20 ml of the ether. No color should develop in the aqueous layer in 1 min.

PREPARATION AND "CONDITIONING" OF ION EXCHANGE COLUMN

Place the two tubes in an upright position, attach a piece of rubber tubing carrying a hose cock (Hoffman type) to the bottom of the tubes, and stratify in each tube a layer of packed glass wool and coarse white sand (10-20 mesh), as shown in Figure 2. Stir about 25 ml of cation exchange resin into a 250 ml beaker containing ca 100 ml H₂O. Treat a portion of anion exchange resin similarly in another beaker. Allow the resins to stand for 10-15 min. to expand. Measure 30 ml of each type of wet resin in graduate, allowing to settle well. Transfer the cation

resin to one tube and the anion to the other, keeping sufficient H_2O in tubes to cover resin by closing hose cock. Attach a series of bent glass tubes, joined with rubber connections to form an S to the bottom of each tube. The height of the open end (X) of the S tube should be adjusted so that when liquid is added to the column and the hose cock is opened, the liquid will flow out until the meniscus is just at the top surface of the resin.

It is advisable to condition new, previously unused portions of resins before use by putting them thru a cycle of appropriate chemical reactions of regeneration (activation) and exhaustion. For the cation resin this is done as follows: Place a fine metal screen in the tube mouth before inserting a stopper with a carry-off tube. Then back wash the column with about 300 ml of H_2O at ca 40 ml per min. to classify the particles. The counterflow is accomplished by attaching the outlet tube from a large carboy of water (which is in an elevated position) to the S-tube at X and regulating the flow with the hose cock. Disconnect carboy tube and allow excess liquid to drain off to $\frac{1}{2}$ inch above resin.

Activate (regenerate) the column by passing 120 ml HCl (1 plus 9) thru it by down flow at the rate of about 8-10 ml per min., introduced from a separatory funnel in the mouth of the tube. Follow this with water until the effluent shows no acidity (ca 200 ml). Then pass 50 ml of 6% NaOH thru the resin to exhaust it and follow with water until effluent *pH* drops to 5 or 6 (universal indicator paper). Repeat the cycle once, then regenerate with HCl (1 plus 9), wash with H_2O until free of acid, and the column is ready for use.

Condition the anion exchange resin in a similar manner by washing (counter-flow) with H_2O , regenerating with 120 ml of 6% NaOH, washing with water until effluent *pH* drops to 7 or 7.5, and then exhausting with 75 ml of HCl (1 plus 9) and washing again with water. Repeat cycle once and regenerate the resin with 120 ml of the 6% NaOH, wash with water, and the column is ready for use.

PREPARATION OF SAMPLE

Fruits.-Juice fruits by grinding and crushing in food chopper or grinder, and strain thru cheesecloth. Citrus fruits are juiced by bisecting and reaming. Immediately heat the juice from fresh fruits in covered Erlenmeyer on hot plate or steam bath to near $85^\circ C$. (10 min. on steam bath), to kill enzymes. Place 100 ml of the prepared juice (or juice sample) in a 200 ml volumetric flask, add acetone gradually with constant shaking to the 200 ml mark. Stopper and mix well and allow to stand several min. Add acetone to mark again and re-mix. Let stand for the precipitate to separate. Add several g of filter aid (Celite), mix again and filter on an 18.5 cm rapid fluted filter (E & D No. 195 has been found satisfactory). Cover filter during filtration. The filtrate should be clear; if it is not, pour back until clear. Treat 100 ml of the filtrate as in A or B depending upon the type of fruit juice. Treat juices containing little or no oils or coloring matter (as apples, pears, etc.) as in A. Treat juices containing oils and ether-soluble coloring matter (such as citrus juices) as in B.

(A) Measure 100 ml of the filtrate directly into a 250 ml separatory funnel. The stem of the funnel is provided with a stopper (No.5) which will fit into the upper tube containing the cation exchange resin, Duolite C-3. Add 25-35 ml of water to the funnel and mix; the liquid should remain clear and is now ready to pass thru the column.

(B) Measure 100 ml of the (50%) acetone filtrate into a 400 ml beaker. Add a boiling tube or beads to the beaker and place on the steam bath, allowing it to remain only long enough to evaporate most of the acetone. (Volume is reduced to about one-half and liquid ceases to boil when agitated, 20-30 min.) Remove promptly and transfer liquid quantitatively to a separatory funnel (125-250 ml)

cool, and extract with a half volume of ethyl ether, shaking moderately. After separation, draw off lower aqueous layer into a beaker and wash ether layer once with 10-15 ml of H₂O. Add a gram or two of filter aid to beaker, stir well, and filter on a Buchner funnel (7 cm) with suction. Wash beaker and funnel once with 15-20 ml of water. Filtration should be rapid and filtrate clear. Transfer filtrate to a separatory funnel as in A, and proceed with the passage of the soln thru the resin columns.

Place the tubes containing the resins (previously regenerated as described under "Preparation of Column") in series as in Figure 2 so that the effluent liquid emerging from the cation exchange resin will flow into the anion exchange resin tube. The tubes should contain sufficient liquid to keep the liquid level at $\frac{1}{2}$ inch above the resin. If the sample soln contains acetone (Procedure A), pass 50-60 ml of 35% acetone thru the resin columns to replace the water in the columns, before passage of the sample soln thru them.

If procedure B was followed, use the column as it was without replacing the water by 35% acetone. Insert the funnel stem into the cation resin tube until the stopper fits tightly. Open the stopcock of the funnel and adjust hose cock so that the liquid flows thru the tubes at ca 7-8 ml per min. Keep the liquid level during passage of the sample soln above the resin column by adjusting the hose cock; otherwise, air may get into the column, causing channeling.

As soon as the soln has passed out of the funnel, add about 25 ml H₂O to the funnel and allow it to pass into the tube. Add 100 ml more H₂O to the funnel and allow it to flow thru the columns. Separate the two tubes and place a small fine screen in the mouth of the lower tube (anion exchange resin) and a stopper carrying a drain-off tube. Back wash the resin with about 300 ml of H₂O at about 50-75 ml per min to remove traces of sugars and other substances. The fine wire cloth screen used can be held in the tube by the stopper holding the tube which carries off the wash water. Drain off excess water to $\frac{1}{4}$ inch above resin.

Place in clean separatory funnel 75 ml of HCl (1 plus 9). Attach it to the mouth of the tube containing the anion exchange resin in which the acids have been absorbed. Elute the organic acids from the resin by passing the HCl (1 plus 9) thru it at a moderate rate of about 8-10 ml per min., rejecting the first 10 ml of effluent. Collect the following eluate in a 100 ml volumetric flask. As soon as all of the acid has passed out of the funnel into the tube, add about 30 ml of H₂O to the funnel and let this percolate thru the tube in the same manner. Stop flow when last of the H₂O reaches surface of resin, unless the receiving flask is full before this time. Make to a volume of 100 ml in the vol. flask and mix. Run a blank on the columns by diluting 50 ml of a soln containing 0.8% malic acid and 0.5% potassium malate (1.1 g malic acid and 45 ml 0.1 N KOH or equivalent, may be used), with 50 ml acetone and 25 ml water, passing the soln thru the column, washing and eluting with HCl (1 plus 9) as above, and making to 100 ml, etc.

Place 0.0, 0.2, 0.04, 0.8, and 1.2 ml of reagent (e) in 5-25 ml glass stoppered cylinders. Make to 2 ml volume with reagent (d). Place 2 ml of the final sample effluent soln in another 25 ml cylinder and in an additional cylinder place 2 ml of the effluent from the blank run on the column in which malic acid and potassium malate were used. Add to each cylinder exactly 1 ml of reagent (c); add 1.9 ml HCl to the cylinder containing sample and column blank and 2 ml HCl to each cylinder containing standards. Add 0.1 ml of H₂O to the cylinders containing sample and column blank. Stopper, shake to mix, and place the cylinders in a stirred bath maintained at 50°C. ± 1.0°C. for 70 min. Remove and cool quickly to about 25°C. in a bath. Make each cylinder to 25 ml mark with ethyl ether (peroxide free), stopper and shake vigorously for 3 min. Allow to stand 4-5 min and transfer most of the ether extract from each cylinder into an 18 X 150 mm test tube by means of glass transfer

tube with rubber bulb attached. The transfer tubes are made by drawing out the end of an 8-10 mm OD glass tube to about 1-2 mm. Add a small quantity (ca 500 mg) of anhydrous Na_2SO_4 to each tube. Stopper and shake or swirl to clear the solution.

Determine the optical density of the extracts at 580 $\text{m}\mu$, using the tube having 0 ml of reagent (e) as the (reagent) blank reading 100% transmission (density 0). Construct a curve from the standard readings, plotting optical density against mmg of galacturonic acid. From the curve obtain the quantity of the acid in the 2 ml of sample effluent shown in mmg. Subtract the blank determination on the columns from the amount found. This is equal to the mmg of galacturonic acid per ml of the original juice, or gives mg per liter directly (p.p.m. w/v).

The method has been applied to several varieties of fruit juices (apple juice, orange juice) and mixed acid solutions; and results of some of these determinations are given in Table 1.

TABLE 1.-Galacturonic acid found and recovered from fruit juices

NUMBER	SAMPLE	GALACTURONIC ACID		
		ADDED PER ML	FOUND	RECOVERED
		<i>mmg</i>	<i>mmg</i>	<i>mmg</i>
1	Apple juice	0	120	-
1	Apple juice	100	222	102
2	Apple juice	0	175	-
2	Apple juice	200	370	195
3	Apple juice	0	101	-
3	Apple juice	100	197	96
4	Orange juice	0	0	-
4	Orange juice	120	121	121
5	Simulated juice	60	63	63
6	Apples	0	48	-
6	Apples	80	126	78

The recoveries appear to be quite satisfactory.

RECOMMENDATIONS.

It is recommended-

(1) That the method for galacturonic acid be subjected to collaborative study after testing the color reaction at 2 hours heating with purified naphthoresorcinol.

(2) That the authentic data be accumulated on samples of fruit juices from sound fruits and that some data also be obtained on juices from decomposed fruits of the same kinds.

(3) That other criteria of decomposition in fruits be studied.

(4) That work on polyphenolase activity as an index of blackheart or decomposition (with darkening of tissues) in pineapple be continued.

• For report of Subcommittee C and action of the Association, see *This Journal*, 34, 49 (1951).

REPORT ON GALACTURONIC ACID IN STRAWBERRY JUICE

By PAUL A. MILLS (U. S. Food and Drug Administration, Federal Security Agency, San Francisco 2, California), *Associate Referee*

Galacturonic acid in apple juice was found by Harris (1) to be a measure of the rot present in the raw material. Attempts were made to apply his method to the analysis of strawberry juice. The method, a modification of that of Deickman and Dierker (2) entailed concentration of the juice, precipitation of pectin, isolation of galacturonic acid together with the fruit acids as their lead salts, and the colorimetric estimation of galacturonic acid with naphthoresorcinol by Tollens' reaction (3).

The naphthoresorcinol reaction is not specific for galacturonic acid. Various writers report positive results with the general class of uronic acids and with pectic acid, but galacturonic acid, or its poly combinations as pectin decomposition products, are all that would be expected to be present in fruit juices (6). Results by this method expressed as galacturonic acid, therefore, are a measure of decomposition.

In this investigation the sample size was reduced from 100 g to 25 g in order to eliminate the time consuming concentration step. This so curtailed the occlusion effect of the citric acid present that only 50 per cent recoveries were obtained. Precipitation with other compounds such as calcium, barium, and strontium, used by Isbell and Frush (5), did not solve the difficulty and attention was directed to the newer ion exchange resins for separation of the acids from interfering substances.

Preliminary experiments with the naphthoresorcinol method as described by Harris indicated that it did not give sufficiently precise results for the quantities of galacturonic acid encountered in the aliquots of strawberry juice used. B. Tollens (3) reported a qualitative test for uronic acids based on the ether-soluble blue color produced by boiling naphthoresorcinol and uronic acids with hydrochloric acid for a few minutes. Later (4) he reported that the presence of a miscible organic solvent aided in the reaction although it did not modify the end product. Deickman and Dierker used alcohol as a solvent for the naphthoresorcinol. Harris apparently considered use of alcohol an advantage. Deickman and Dierker stated that temperatures of reaction higher than 50°C. led to losses and used a reaction time of 90 minutes at 50°C.

Experiments were conducted to determine the controlling factors in the color development and to discover optimum concentrations of reagents and conditions necessary to "sharpening" the reaction. It was found that the ether solution of the blue color absorbed most strongly at 570 $m\mu$. Optical densities were measured throughout at this wave length with a Beckman Model DU spectrophotometer. The blue naphthoresorcinol-galacturonic acid compound was developed in an arbitrarily selected

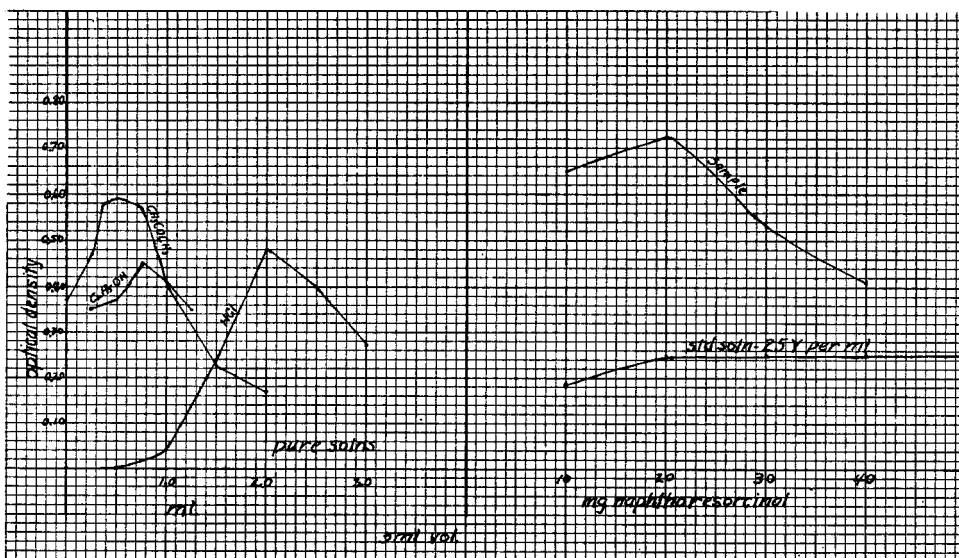

Fig. 1.—Relative effect on color density of varying concentrations of HCl, acetone, alcohol, and naphthoresorcinol.

volume of 5 ml. It was found that the color intensities were influenced by the amounts of hydrochloric acid, acetone, alcohol, and naphthoresorcinol present in the reaction mixture. Figure 1 shows graphically the relative effect when each reagent was varied separately. A distinctly optimum quantity was shown for each reagent. Substitution of acetone for alcohol markedly increased the color intensity. Figure 2 shows standard curves at three different levels of naphthoresorcinol and illustrates the effect of excessive naphthoresorcinol in the higher range of galacturonic acid.

The time of reaction at 50°C. was also investigated and it was found that the presence of an organic solvent materially influenced the speed of the reaction. It required three hours with acetone or alcohol present and four hours where water alone was used to obtain maximum colors. Figure 3 shows graphically the relation between color intensity and time of reaction in the presence of acetone, water alone, and alcohol. This experiment illustrates further the marked increase of color developed in the presence of acetone over that developed in the presence of alcohol. Colors developed in the presence of water alone proved practically as strong as with acetone but required considerably more time.

Color developed at 35°C. did not reach maximum intensity even after six hours. Figure 3 shows this also. At 90°C., color reached a maximum in three minutes, but its intensity was only about one-fourth of that at 50°C.

These experiments showed the optimum conditions for color develop-

ment in 5 ml volume to be as follows: 2.0 ml hydrochloric acid (conc.), 2.0 ml acetone solution (1+3), 20 mg naphthoresorcinol and 1.0 ml of water solution of sample. The reaction was carried out in a glass-stoppered test tube of ca 50 ml capacity, heated in a controlled water bath at 50°C. for three hours. It proved advisable to prepare a solution of 10 mg naphthoresorcinol per ml in 1+3 acetone solution and to add 2.0 ml of this solution to the test tube, rather than weigh 20 mg portions of dry reagent. Naphthoresorcinol was found to be stable in this solution for 24 hours, but preferably only enough was prepared for each series. The color in ether solution, dried with anhydrous sodium sulfate, was found to be stable for one hour at room temperature.

Using these conditions color standards were duplicable within 5 per cent.

Separation of acid from the juice by ion exchange resins.—Duolite C3 (cation resin) and A4 (anion resin) produced by Chemical Products Company, Redwood City, California, were used. Other resins of similar properties should be equally satisfactory.

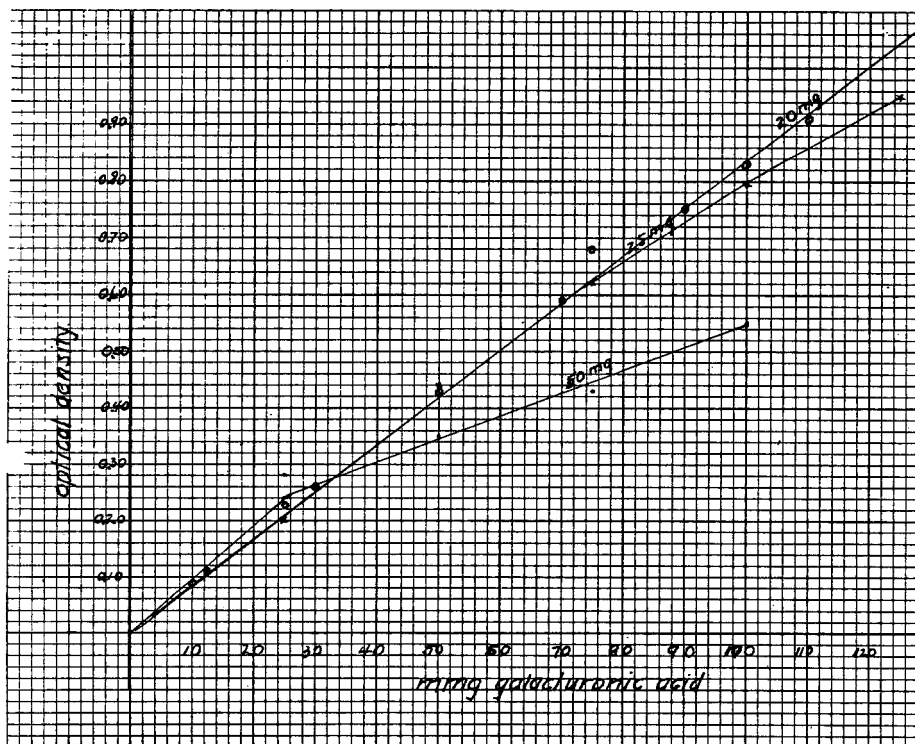

FIG. 2.—Standard curves showing effect of naphthoresorcinol concentration.

It was found that these resins would not adsorb from the 80% alcohol solution used for pectin precipitation. However, pectin is not adsorbed by the resins, so this alcohol precipitation was found unnecessary. The prepared juice was passed first through the cation resin and then through the anion adsorber. All of the acids were retained on the anion resin while the sugars and pectin passed through. The acids were removed from the resin with hydrochloric acid. Complete recoveries were obtained with

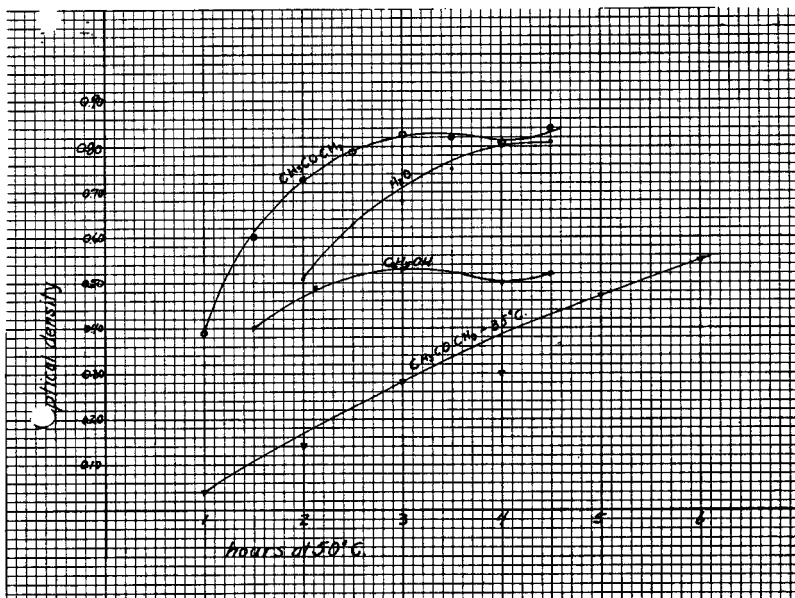

FIG. 3.—Effect of reaction time at 50°C. on color density with water only, acetone or alcohol present in the reaction mixture, and also the effect at 35°C. using acetone.

1 to 5 mg of galacturonic acid in 25 g of either water, citric acid solution, or strawberry juice. The eluted fruit acid solutions contained some fruit color and some substance that interfered with the naphthoresorcinol reaction. These were removed by treatment with activated carbon (Nu-char W). No detectable quantity of galacturonic acid was adsorbed by the amount of carbon used.

Adsorption tubes.—Tubes as pictured in Figure 4 were used. These are patterned after apparatus used by the resin manufacturers for testing their products. Tubes of this design have the advantage of always keeping the resin covered with water and also of reducing the over-all height of the equipment. The tubes are 17 mm in diameter and 300 mm in length. They are charged with ca 30 ml of expanded resin. This volume of A4

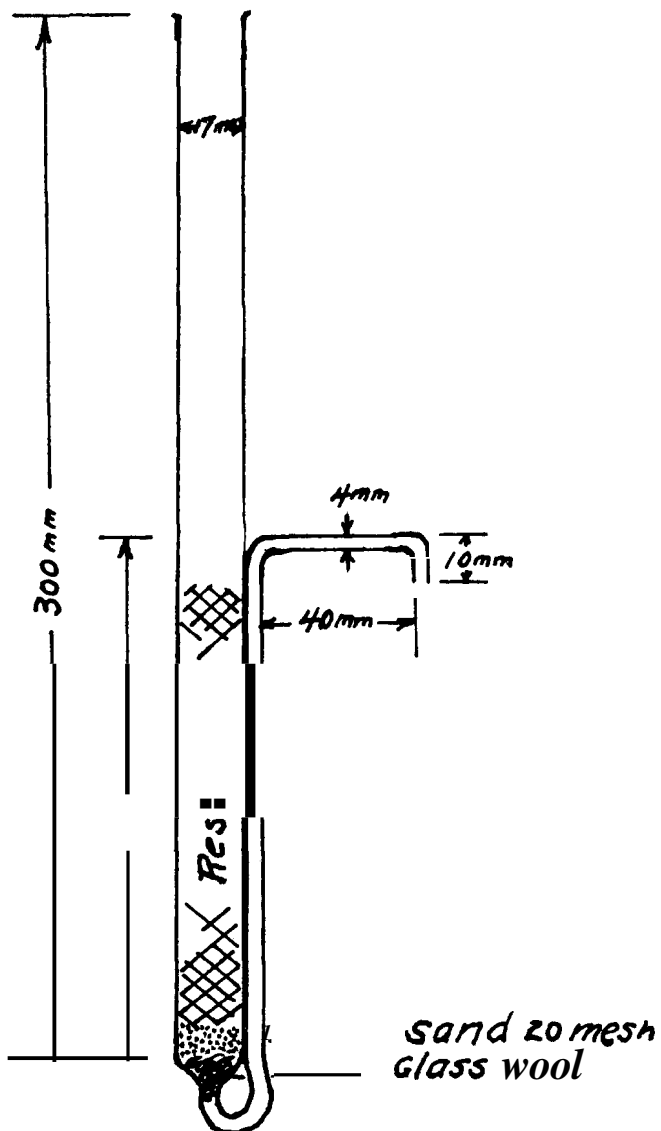

FIG. 4.-Adsorption tube.

(anion) resin has an adsorption capacity of ca 500 mg of citric acid, so that the sample size is limited to a maximum of 50 g of strawberry juice.

A gravity source of distilled water was set up with screw clamp connections to each tube.

Particle size of the resins as received was 12 mesh and smaller. This was screened through a 20 mesh sieve and that retained on the screen discarded.

PROPOSED METHOD

PREPARATION OF SAMPLE

Whole strawberries.-Heat berries, preferably 200-500 g, in a boiling water bath until the temperature of the fruit reaches 00°C. Cool and pulp for a $\frac{1}{2}$ min. in a Waring Blendor with 1%-2% of Supercel or Filtercel. Transfer to centrifuge tubes and centrifuge for 5 min. at ca 1500 r.p.m. Filter the supernatant juice thru Pyrex glass wool or cotton. Samples of entirely rotten berries produce an extremely slimy juice which is difficult to filter. Dilute such fruit with an equal quantity of water before pulping.

Strawberry juice.-Use as received.

Preparation of adsorption columns.-Place a quantity of the screened dry resin in a beaker and cover with water for one hour or longer to expand (do not expand the resin in the adsorption tubes or breakage may result). Fill the adsorption tube ca half full of the expanded wet resin. Completely exhaust the cation resin (C3) with 4% NaOH and backwash the column with water from the bottom, allowing the water to overflow the top of the tube at such a rate that the resin is thoroly agitated but none is lost except very fine particles. Allow the tube to drain until the resin is just covered, and then wash from the top at a rate of ca 5 ml per min. until most of the NaOH is removed. Regenerate the resin with 1+3 HCl and wash with water from the top at a rate of 5 ml per min. until the excess acid is removed (pH of effluent of 5-6, using pH paper).

Exhaust the anion resin (A4) with 1+3 HCl, backwash, wash with water, and then regenerate with 4% NaOH. Wash until free from alkali. This constitutes a cycle. Repeat twice more before putting columns into use for the first time.

Backwashing reclassifies the resin particles so that the larger particles are at the bottom, breaks up channels that may have formed, and removes any entrapped air bubbles which interfere with adsorption.

To prepare the columns for re-use.-After a sample has been adsorbed and the anion resin stripped, it is prepared for re-use by exhausting the cation column with 4% NaOH, backwashing, draining, and washing from the top to remove excess NaOH, fruit color, etc., then regenerating with 1+3 HCl, and washing free of excess acid.

The anion column is already exhausted. Simply backwash, regenerate with 4% NaOH, and wash free of alkali.

Adsorption of acids from strawberry juice.-Mount the cation column so that its outlet tube delivers into the anion column and place a dropping funnel of ca 75 ml capacity in the top of the cation column by means of a rubber stopper. Transfer 25 g of juice to the dropping funnel with ca 25 ml of water. Allow the soln of juice to drop into the cation column at a rate of ca 5 ml per min., with the cation column discharging into the anion tube. After the sample has passed into the resin, rinse the dropping funnel, remove, attach the gravity source of distilled water, and wash at a rate of 5 ml per min. with ca 150 ml. Remove the cation column, place a 100 ml volumetric flask under the discharge from the anion column, and add 10 ml 1+3 HCl to the top of the anion column. Attach the water supply and wash at a

rate of 5 ml per min. until ca 90 ml have been collected. Add ca 0.5 g of activated carbon (Nuchar W is satisfactory) to the flask. Shake and immerse in boiling water for 30 min. Cool, make to volume, and filter thru quantitative paper, pouring back until bright. Add a drop of chloroform for preservative.

DETERMINATION OF GALACTURONIC ACID

APPARATUS

Glass stoppered test tubes.-ca 23 X 150 mm.

Water bath.-Controlled at 50°C. +0.5°.

Photometer.-Capable of determining optical densities at 570 m μ .

Absorption cells with stopper.-ca 15 mm diameter.

NOTE: Druggist's vials 15 X45 mm with cork stoppers can be used after careful matching. These are very cheap, remarkably uniform and will fit the small carrier in a Beckman DU spectrophotometer.

REAGENTS

a,d-Galacturonic acid.-H. O. Eastman is satisfactory.

Standard soln.-Dissolve 1.000 g of a,d-galacturonic acid in water and dilute to 1 liter. Add a drop of chloroform for preservative.

Naphthoresorcinol.-Highest purity. That used in these studies was obtained from A. D. MacKay, Inc., 198 Broadway, N. Y. City.

Citric acid.-C.P. crystals.

Hydrochloric acid.-(Conc.)

Acetone soln.-1+3.

Chloroform.-C.P.

Ethyl ether.-U.S.P.

Anhydrous sodium sulfate.-C.P. powdered.

PREPARATION OF STANDARD CURVE

Into each of seven 100 ml vol. flasks weigh ca 250 mg of citric acid (to simulate a sample) and add 0, 1,3,5,7,9, and 11 ml of the standard soln. Dilute with water to 100 ml and add a drop of chloroform to each. These represent 0, 10, 30, 50, 70, 90, and 110 mmg per ml.

Pipette accurately 1 ml of each of the diluted standard solns into g.s. test tubes and to each test tube add from a burette 2.0 ml HCl (cone.). Prepare a soln of 150 mg naphthoresorcinol in 15.0 ml 1+3 acetone soln and add 2 ml accurately measured to each test tube. Mix and place in water bath at 50°C. for 3 hours. Cool tubes under the water tap and add 20.0 ml ethyl ether to each, stopper; shake vigorously at least 2 min., and allow to settle.

Place 0.25 g of anhydrous sodium sulfate in each of 7 absorption cells and fill one cell with the ether layer from each test tube. Stopper, shake thoroly, tap gently to settle the sulfate, and measure optical densities at 570 m μ , using the 0 standard cell to set the instrument at 0.

Plot optical densities against mmg of galacturonic acid. This should yield an essentially straight line.

DETERMINATION OF GALACTURONIC ACID IN SAMPLE SOLUTIONS

Proceed as directed under Standards, substituting 1 ml of the decolorized solns of fruit acids for the standard solns. Always include a zero standard to adjust the spectrophotometer to zero reading.

RECOVERY EXPERIMENTS

Table 1 shows analyses of strawberry juices prepared in the laboratory, and recoveries of added galacturonic acid.

TABLE I.-*Recovery of galacturonic acid from strawberry juice*

	PRESENT IN JUICE	GALACTURONIC ACID		
		ADDED	TOTAL	RECOVERED
	mg	mg	mg	mg
1	1.0	3.0	4.0	3.0
2	1.2	2.0	3.2	2.0
3	0.6	4.0	5.8	4.2
4	0.9	2.0	3.0	2.1
5	0.5	3.0	3.4	2.9
5	0.4	1.0	1.4	1.0
6	2.3	2.0	4.3	2.0
7	1.2	2.0	3.3	2.1
7	1.2	2.0	3.3	2.1

It is recommended that some further study of the color reaction be made and authentic data on strawberry juice be accumulated.

ACKNOWLEDGMENT

Anthony W. Daly, San Francisco District, Food and Drug Administration, contributed valuable assistance in translating foreign language literature.

BIBLIOGRAPHY

- (1) *This Journal* 31,501 (1948).
- (2) *J. Biol. Chem.*, 163, 753 (1946).
- (3) *Ber.*, 41, 1783 (1908).
- (4) *Ibid.*, 1788 (1908).
- (5) *J. Research, Nat. Bur. Standards*, 32, 77 (1944).
- (6) *Wallerstein Lab. Com.*, 10, 41 (1947).

REPORT ON URIC ACID IN CEREAL PRODUCTS

By HELEN C. BARRY (Food and Drug Administration, Federal Security Agency, New Orleans, La.), *A880ciate Referee*

The occurrence of uric acid as an end product in the nitrogen metabolism of insects, birds, and reptiles makes it a significant compound to be considered in the search for chemical indices of filth in food. Since Beck (1) proposed its use as an index of the soluble filth of insect excreta in fruit juices, uric acid has assumed importance in collaborative studies on filth in various types of foods.

In investigating the determination of uric acid in cereal products, a method combining the quinoline extraction of Duggan (2) and the colori-

metric method of Fearon (3) using 2:6 dichloroquinone was tried. It was possible to carry standard aliquots through the extraction and development of color and to obtain a satisfactory curve on the Beckman spectrophotometer at 440 μ .

Samples were extracted directly with quinoline by shaking for 2 hours on a shaking machine. The uric acid was stripped from the quinoline with 2% dibasic sodium phosphate. The sodium phosphate solution was washed with benzene to remove traces of quinoline and then diluted to volume. To an aliquot diluted to 25 ml, color reagent was added and the solution read at 440 μ . In this preliminary report no further details will be given, because additional work must be done to overcome the drawback of the Fearon method: rapid fading of the color necessitating rigid adherence to time limits.

Time permitted running only four samples, in duplicate, by the procedure described. Results are reported in Table 1.

TABLE 1.-Apparent uric acid content of four cereals

PRODUCT	APPARENT URIC ACID	INSECT FRAGMENTS
	<i>mmg POT 50 g</i>	<i>POT 50 g</i>
Retail packaged flour, self-rising	58 56	17
Retail packaged flour	58 53	8
Storage flour	18,650 18,650	Grossly contaminated
Retail packaged corn meal, yellow, degerminated	172 178	7

Solutions of the flours were practically colorless and, when compared to a reagent blank before the addition of color reagent, gave 99.4-100% transmission. This was not so in the case of the corn meal, where the transmission fell to 97.6-97.8% because of color extracted.

Preliminary experiments indicate that the quinoline extraction-2:6 dichloroquinone colorimetric method of determining uric acid has promise when applied to cereals. Results on the four cereals tested indicate that there may be a significant spread in the uric acid content of products considered clean and those containing excessive insect filth. This would be particularly true of cereals which were infested in storage and bolted to remove insects and large fragments.

It is recommended* that the study of uric acid in cereal products as an index of filth be continued.

*For report of Subcommittee C and action of the Association, see *Thio Journal*, 34,49 (1951)

REFERENCES

- (1) BECK, J. W., U. S. Food and Drug Administration, San Francisco Station, unpublished report, June 1942.
- (2) DUGGAN, R. E., *This Journal*, 29, 76 (1946).
- (3) FEARON, W. R., *Biochem. J.*, 38, 399 (1944).

REPORT ON SUCCINIC ACID IN TOMATO PRODUCTS

By HALVER C. Van Dame (Food and Drug Administration, Federal Security Agency, Cincinnati, Ohio), *Associate Referee*

Succinic acid has been found among the products of mold metabolism and is present in decomposed eggs and fish. This year a preliminary investigation was made to determine whether succinic acid might be used as a chemical index of decomposition in tomato products.

The following method was devised to separate succinic acid from tomato products such as juice, puree, and catsup. It is essentially the method used by Hillig (1) on eggs.

METHOD

To 100 g of purée, juice, or catsup, in a 250 ml centrifuge bottle, add 25 ml of INH_2SO_4 and add sufficient H_2O to make a total weight of 200 g. Mix well with shaking and centrifuge at ca 1200r.p.m. for 10 min. Decant the supernatant liquid and filter it thru fluted filter paper. To 100 ml of the filtrate add 50 g of ammonium sulfate, mix well, and put into a 150 ml continuous ether extractor. Extract with ether for 5-6 hours. Add 10 ml H_2O to the ether in the flask and evaporate off the ether. Proceed as in the method for "Separation for Succinic Acid."¹

EXPERIMENTAL

A purée of fresh ripe sound tomatoes was made in a small cyclone. A 100 gram portion of this purée was analyzed by the above method, together with a 100 gram portion to which 20 milligrams of succinic acid had been added. Several other commercial purees with mold counts from 12 to 88 and duplicates of these same purees to which succinic acid was added, were also analyzed by the above method. The following table gives the results of these analyses.

The tabulated results show that more succinic acid is present in purée made from tomatoes containing rot than from purée made from sound tomatoes. Other acids which gave insoluble barium salts in 80% alcohol, and which gave bands on the silicic acid column, were found both in purée made from sound tomatoes and from purée made from tomatoes containing rot. These acids were not separated and identified or measured, but appeared to be present in greater quantities in the purée made from tomatoes containing rot.

¹ *This Journal*, 33, 722 (1950).

PRODUCT	MOLD COUNT	SUCCINIC ACID ADDED/1011 GRAMS	SUCCINIC ACID FOUND/100 GRAMS	RECOVERY
		<i>mg</i>	<i>mg</i>	<i>per cent</i>
Fresh Tomato Purée made in Lab.	0	0	2.6	-
Fresh Tomato Purée made in Lab.		20.0	19.5	84.7
Purée No.1	12	0	1.0	-
Purée No.1	12	10.0	9.4	84.0
Purée No.2	88	0	8.4	-
Purée No.2	88	20.0	25.6	86.0
Purée No.3	86	0	10.6	-
Purée No.3	86	20.0	25.6	78.0
Purée No.4	32	0	5.0	-
Purée No.5	64	0	6.7	-

CONCLUSIONS

(1) A method has been formulated which can be used to separate succinic acid from tomato products.

(2) This method gives a fair recovery of known amounts of succinic acid.

(3) Purée made from fresh sound tomatoes contains small amounts of succinic acid.

(4) Greater amounts of succinic acid are obtained from purées containing rot than from purées of sound tomatoes.

(5) Other acids forming insoluble barium salts in 80% alcohol are present in varying degrees in tomatoes.

It is recommended* that this problem be subjected to further study.

No reports were given on fish products; shell-fish; animal fecal matter (chemical indices); pineapple (decomposition, carbohydrate); pineapple (blackheart); strawberries (decomposition); uric acid in nuts; or fish (indole).

No reports were made on gelatines, dessert preparations, and mixes.

* For report of Subcommittee C and action of the Association, see *This Journal*, 34, 49 (1951).

REPORT ON METALS, OTHER ELEMENTS, AND RESIDUES IN FOODS

By H. J. WICHMANN (Food and Drug Administration, Federal Security Agency, Washington 25, D.C.), *Referee*

The efforts of those interested in methods for the determination of deleterious or toxic substances in foods, up to 1949, have crystallized in chapter 24 of the Seventh Edition of the *Book of Methods*. This year's report is concerned with loose ends and such items as the Referee feels need special attention. It can be divided into observations on inorganic elements and on those organic compounds that constitute the majority of the residues on or in foods or agricultural products at the present time.

COPPER AND ZINC

There are no Associate Referee reports this year on the determination of either copper or zinc. Associate Referees on copper have been endeavoring to perfect an all-dithizone method, with indifferent success so far. No reports have appeared on zinc for a number of years. The toxicity of either of these metals is of a rather low order and therefore their determination is not of prime importance in the residue field. This may be the reason for part of the lack of interest and scarcity of collaborators. However, copper and zinc are important in the biochemical field and they do have economic importance, as for example, in the beverage field, for beer. Therefore the Referee believes that investigations should not be dropped, but perhaps they can be integrated with investigations in other sections of this Association. In former years the Referee has recommended that all-dithizone methods for the determination of copper be investigated, and that the present zinc method be recast in line with the majority of other dithizone methods, so as to avoid the extraction of zinc from glassware by alkaline reagents. The Hellmut Fischer method¹ for extraction of zinc from slightly acid acetate solutions might be investigated in line with the above suggestion. A recommendation for the continuation of the work on copper and zinc appears to be justified.

MERCURY

Mercury methods were removed from the *Book of Methods* last year, for reasons given by the Referee. An attempt was made then to replace the deleted method but the new one did not stand up under collaborative test. The Associate Referee investigated some probable reasons for the discordant results and submitted a revised method this year. Most of the collaborative results are satisfactory, but low results were reported by two collaborators. There may be a logical reason for the low results of one of them, and this should be checked by the Associate Referee, the method

¹ *Z. Anal. Chem.*, 107,241 (1936).

rewritten with adequate warnings if necessary, and the revision resubmitted to collaborators. The special apparatus needed in the sample preparation of certain kinds of samples (samples containing sugars or other carbohydrates, apples for example) has never been described in any publication. The Referee therefore recommends that the Associate Referee include in this year's report a proper illustration and description of the apparatus and method of sample preparation, so that it will be on record. Enough doubt has probably been created by certain of the collaborative results, so that a recommendation for adoption is not justified until further work can be carried out.

FLUORINE

Two noteworthy publications on fluorine determinations appeared after the 1950 meeting of the Association. Willard and Horton² investigated a long list of compounds for their suitability as indicators in the titration of fluorides with thorium nitrate solutions. The two best two-color indicators were found to be Purpurin-sulfonate and Alizarin Red S, in the order given. The A.O.A.C. methods use both of these indicators—the former in the rapid method with zirconium titration, and the latter in the official method with thorium titration. The above authors also found the two flavinoids, quercetin and morin, were excellent as one-color visual and fluorescent indicators.³ Quercetin and morin were said to have some points of superiority even over the purpurin or alizarin indicators. **It** seems here is an opportunity for somebody to check these results and advise the A.O.A.C. whether it would be worth while to take the necessary steps to change the indicators used in the fluorine methods.

CHLORINATED HYDROCARBONS

No report has been received on the determination of DDT this year. The new *Book of Methods* devotes considerable space to the determination of DDT; the first one of the newer pesticides to reach the adoption stage. Possibly by the next meeting, an estimate can be made of its value as well as of its shortcomings.

A recent development in the determination of chlorinated hydrocarbons is the publication⁴ of a method for DDT and methoxychlor based on the nitration of the dehydrochloride to benzophenones and production of red (instead of blue or purple color as with nitrated DDT) color with sodium methylate. This appears feasible in cases where the two insecticides are not mixed. **If** they are mixed the colors are additive. Attention is now invited to this year's report on the differentiation of DDT and methoxychlor, mostly in animal products. **It** seems that methoxychlor is sensitive to strong sulfuric acid and DDT is not. Both fats and methoxychlor are

² Analytical Chemistry, 22, 1190 (1950).

³ *Ibid.*, 22, 1194 (1950).

⁴ PRICKETT, KUNZE, and LAUG. *This Journal*, 33, 880 (1950).

held on the Davidow⁵ chromatographic column (celite and fuming sulfuric acid) and the DDT comes through with very little interfering organic matter and can then be determined by either the Schechter-Haller or the benzophenone procedure of Prickett, Kunze, and Laug. The Davidow chromatograph removes the coloring matter but not all of the waxes from plant extracts. This small amount of residual organic matter will probably not interfere in the Schechter-Haller method for DDT, but it may in the benzophenone method. There seems then to be no great obstacle to the determination of DDT in the presence of methoxychlor as found in spray residue, fats, or other biological material. We then come to the determination of methoxychlor either alone or in mixtures.

The Fairing⁶ method for methoxychlor is specific; DDT does not interfere. It is based on the formation of a red color on treating the dehydrochloride with 85 per cent sulfuric acid. The critical point in the method is the separation of the methoxychlor or its dehydrochloride from other organic matter which can produce chars or a variety of colors with the strong sulfuric acid. The Fairing method prescribes an acetone separation of fats or waxes. The Associate Referee applied this method successfully to methoxychlor in lard but he had certain unexplained difficulties when the compound was dissolved in butter or extractives from liver. It seems therefore, that the problem of the determination of DDT in mixtures of DDT and methoxychlor is well in hand, but the determination of methoxychlor is not, even though the presence of DDT offers no difficulties. A recommendation for continuation of this work is logical.

The Referee calls attention to the publication⁷ of a spectrophotometric method for the determination of technical chlordane. The commercial product is a variable mixture of isomers and related compounds of various degree of toxicity. The colors produced by a diethanolamine-potassium hydroxide reagent with some of the isolated components vary from no color to red or blue-red. Fortunately, these colored reaction products have overlapping absorption bands and an estimate of technical chlordane can be made without resolution of the individual color components by using certain technical products as standards and adapting an optimum compromise wave length in the spectrophotometric reading of the colors. This makes the method empirical but usable if the standards and the commercial product found in residues or other materials do not vary too widely in composition from batch to batch. The Referee believes that this method requires a certain amount of "shaking down" before the appointment of an Associate Referee and collaboration become advisable.

A reliable method for the determination of benzenehexachloride is urgently needed at the present time. Bitter experience has shown that benzenehexachloride has an unfortunate affect on the flavor of many agri-

⁵ DAVIDOW, BERNARD, *This Journal*, 33, 130 (1950).

⁶ FAIRING, J. D., *Advances in Chemistry*, No. 1, 260 (1950).

⁷ DAVIDOW, BERNARD, *This Journal*, 33, 886 (1950).

cultural root crops sprayed directly or which have been grown on soils treated with the insecticide to control wire worms or other soil pests. The flavor of other products sprayed with it are said to be unfavorably affected by the canning process. Peanuts, often rotated with cotton usually heavily sprayed with BRC, is the latest addition to the list of crops unfavorably affected in flavor by this insecticide. Benzenehexachloride has actually been found in the oil of peanuts grown on soils treated with technical BRC or lindane. The method used in this investigation was the Davidow method⁸ based on the ultra-violet absorption of the tri-chlorobenzene with a "base line" technic to compensate for the effect of the ultra-violet absorption of interfering organic compounds. The method is not too sensitive and 80 gram samples (approximately 40 grams of peanut oil) had to be worked up in order to get reliable results. The question of interference has not been settled in the case of a number of other commodities and a check method is therefore badly needed. The Referee knows of present intensive work on two colorimetric methods. One colorimetric method has been abandoned because the interference of plant extractives could not be circumvented. There is plenty of activity on the BRC front, but only time will tell what the net result will be.

No method other than the non-specific chlorine method is known for the determination of toxaphene. The determination of aldrin and dieldrin are under investigation.

PARATHION

The determination of parathion is still complicated by the problem of the "natural blanks" produced by some agricultural products. The Associate Referee did not make material progress in the elimination of these natural colors. The practice of subtracting a blank produced by unsprayed material may be useful in experiments with adequate controls, but regulatory officials rarely possess unsprayed materials, and even if they did they could not be sure that the blanks would not fluctuate widely according to different growing conditions. There is therefore a doubt in their minds about the accuracy of parathion results, especially in the case of leafy vegetables, members of the cabbage family, and notably in tobacco. This uncertainty is the weak point of the method. The Referee notes an article by Blinn and Gunther⁹ on the interference of methyl anthranilate in estimations of parathion in grapes and citrus fruits. They found that repeated extractions of the benzene extract with 10 per cent hydrochloric acid before reduction, diazotization and coupling of the parathion removed the interference of the methylanthranilate. It is suspected that the problem may not be so simple in the case of the other products mentioned above. This all points to the need of a check method for parathion and continuation of work on this project.

⁸ DAVIDOW and WOODWARD, *This Journal*, **22**, 751 (1949).
⁹ BLINN and GUNTHER, *Analytical Chem.*, **22**, 1219 (1950).

EFFECT OF PROCESSING ON THE DECOMPOSITION OF PESTICIDES AND EFFECT ON METHODS OF ANALYSIS

Last year the Association had an excellent report on the decomposition of certain insecticides by the canning process and the affects on flavor. Decomposition was measured by decreases in the insecticide by the usual analytical methods. Because the nature of the decomposition products were not known it could not be determined if the results were accurate or had been influenced by the breakdown products. No report on this topic has been received this year. The Referee regrets this very much and hopes that this very important subject will not be dropped.

An interesting example of the possible effect of the processing of an agricultural crop on the decomposition of pesticides came to the Referee's attention this year. When peppermint plants sprayed with fermate, one of a series of important thiocarbamate fungicides, were steam-distilled for the peppermint oil, carbon disulfide and other volatile decomposition products were found in the oil. The oil contained no fermate, only its decomposition products. The determination of the thiocarbamates depends upon their complete conversion into carbon disulfide by heating with acids, separating it out of the oil with air and absorbing it in a copper solution with the formation of the yellow color of the copper thiocarbamate. In this case the carbon disulfide in the oil could be calculated back to the fermate on the green plants only if the batch weight of the oil and peppermint plants were known. Peppermint oil containing carbon disulfide in parts per million may not be a serious health hazard, but it certainly will have a most serious deleterious effect on the quality of oil.

SODIUM FLUOROACETATE (1080)

A method for the determination of the rodenticide 1080 in foods was adopted as first action last year. Careless handling of the product in warehouses or food manufacturing plants in rat eradication campaigns may dangerously adulterate foods. The method has been used in several important investigations during the year, but no improvements in the quantitative recovery of 1080 from foods have been made. The analysis is based on a chromatographic separation of organic and inorganic fluorine and a fluorine determination of the former fraction. The Associate Referee can now differentiate the monofluoroacetic acid from acetic acid and the di- and tri-fluoroacetic acids which have a much lower toxicity. A qualitative check determination, especially when very small quantities of organic fluorine are found in foods or in autopsies of suspected poisoning cases, is very desirable. Monofluoroacetates can be converted into indigo (as can the monochloroacetates) provided about 5 milligrams are available for the test. Monofluoroacetic acid is so very toxic, that it may not always be possible to isolate 5 milligrams from a poisoned animal. If 1080 is spilled on foods, the dilution factor may also be so great that it may not be easy

to isolate 5 milligrams. A qualitative test sensitive to one milligram, or preferably less, of monofluoroacetic acid extracted from foods or animal tissues (extracts may contain interfering substances) is highly desirable. It is to be hoped that the thioindigo test mentioned by the Associate Referee will fulfill its early promise. Continued work on quantitative phases of the 1080 determination is recommended.

RECOMMENDATIONS*

It is recommended-

(1) That work on the methods for the determination of copper and zinc be continued.

(2) That the method for the determination of mercury be revised and then evaluated by further collaboration.

(3) That the studies on the methods for the determination of parathion be continued.

(4) That the studies on the determination of methoxychlor and the differentiation between DDT and methoxychlor in plant and animal products be continued.

(5) That the effect of canning and other processes on the decomposition of the newer pesticides be further studied with respect to the nature of the possible decomposition products and their effects on methods of analysis.

(6) That the work on the determination of 1080 and a qualitative test for 1080 be continued.

REPORT ON MERCURY

By A. K. KLEIN (Food and Drug Administration, Federal Security Agency, Washington, D. C.), *Associate Referee*

The purpose of the present collaborative study was to determine the relative merits of two methods of evaluating micro amounts of mercury. The two methods under study were the one devised by Laug and Nelson, *This Journal*, 25, 399 (1942), and the one proposed by the Associate Referee. The latter, a modification of the one employed by Cholak and Hubbard, *Anal. Chem.*, 18, 149 (1946), was outlined briefly in last year's report. Both are colorimetric procedures, employing the reagent, dithizone. In the former, mercury is finally extracted and evaluated as the dithizonate from an aqueous solution buffered at a *pH* of 6.0. In the latter method, the dithizone extraction is carried out in a dilute sulfuric acid solution.

As stated previously, *This Journal*, 32,351 (1949), Laug's method of sample preparation, a digestion of sample with nitric and sulfuric acids under reflux, is satisfactory for biological materials, but not for fruits or vegetables, or similar waxy products. The addition of potassium perman-

* For report of Subcommittee C and action of the Association, see *This Journal*, 34, 49 (1951).

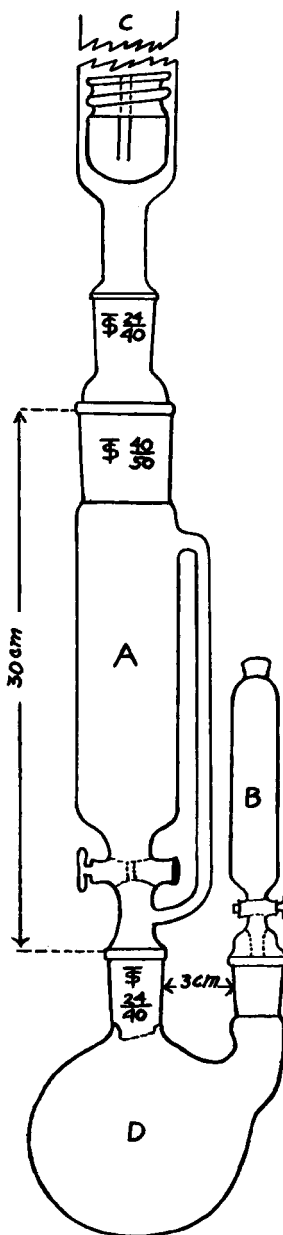

FIG. 1.—Special Digestion Apparatus

Unit A, modified Soxhlet, 5 cm O.D., 200 ml capacity before overflow. Unit B, dropping funnel, $\text{F } 24/40$, capacity 75 ml. C, Friedrichs condenser, 35 cm total length. D, 500 ml digestion flask with two $\text{F } 24/40$ holes, 3 cm apart, for clearance of A and B.

ganate during the reflux period makes possible the quantitative evaluation of mercury in these refractory materials, but a variable mercury blank is then introduced. The alternative is to effect an almost complete destruction of organic matter by wet digestion. Consequently a special apparatus is used, one which traps the water in the sample and also permits the addition of nitric acid as needed, so that an effective wet oxidation is obtained without loss of mercury. This apparatus was described in previous reports. For the reader's convenience, however, a drawing is supplied in Figure 1.

As part of the collaborative study, each chemist was supplied with the digestion apparatus, an "unknown" in duplicate, a practice sample, and a set of detailed directions. The practice sample, weighing about 100 g, was made from a batch of finely comminuted fresh tomatoes, tested and found to be free of mercury. The "unknown," weighing about 25 g, part of the same batch, contained 18.0 micrograms of added mercury as the dichloride. To both unknown and practice samples the following metals were added: Cu, Pb, Bi, Zn, Co, Ni, and Cd, in the respective amounts of 2000, 500, 100, 1000, 100, 100 and 100 micrograms per 25 g of sample.

In order to rule out variables, collaborators were requested to divide the final diluted digests of the unknown into two equal aliquots, and to test the aliquots by the two procedures. Obviously, the amount of mercury which should be present in each aliquot was 9.0 micrograms. Collaborators were encouraged to comment on each procedure and to state their preference. Their results are as follows:

Mercury Results in Micrograms per Aliquot

<i>Collaborator</i>	<i>Laug Procedure</i>	<i>Klein Procedure</i>
A		5.7, 6.2
B	8.8, 9.7	8.7, 8.7
C	9.7, 9.7	8.4, 8.8
D	8.7, 8.7	9.2, 9.3
E		9.5, 8.5
F	9.3	9.0, 11.0
G	3.7, 1.2	2.0, 1.0

When the values submitted by collaborator G are excluded from the calculations, the average result by the Laug procedure is 9.2, and 8.6 by the Associate Referee's method. Due to the urgency of regulatory work collaborator A was not able to submit more than a hasty report. His reason for not submitting results by the Laug procedure was that he was unable to remove from the reagents metals which combine with dithizone. Collaborator E, likewise, was not able to remove these interferences. In a private communication to the author Laug stated that only the very best analytical grades of reagents should be used in his method. This is particularly true of the potassium bromide and the disodium phosphate-potassium carbonate buffer, reagents 5 and 6, of his published procedure.

When reagents of initial poor quality are used, the removal of metal impurities by dithizone extraction is very difficult. In order to facilitate this removal of metals from the buffer, reagent 6, he now prepares the solution in exactly one-half the concentration previously described in the original method. Subsequently, of course, 20 ml of the diluted buffer, instead of 10 ml of the more concentrated solution, is added to effect a pH of 6.0 in the final solution evaluated for mercury.

The very low values submitted by collaborator G caused much concern, especially as he had obtained satisfactory results in practice runs. He observed that the repeated use of Silicone grease on the connections of the apparatus had caused an accumulation of the lubricant in the flasks during the digestion of the unknowns. He was fearful, therefore, that the grease deposit had somehow prevented the subsequent recovery of mercury, probably by co-precipitation.

Consequently, the Associate Referee made a short study of the effect of Silicone grease. He observed that the judicious use of the lubricant on the connections caused no lowering of the mercury recoveries. When, however, Silicone was added to the digestion flask, very low recoveries invariably resulted, in spite of prolonged digestion with the mixed acids. Thus, in a recovery run with 25 micrograms of mercury, added to 50 g of ground potatoes to which 25 mg of Silicone had been added, a final value of 9.5 micrograms of mercury was obtained, representing a loss of 62%. Obviously this lubricant should not be used. The Associate Referee uses colorless petrolatum.

In the instructions to the collaborators, the chemists were advised to perform the initial dithizone extraction of digest aliquots after they had been adjusted to 1.0 *N* by dilution with water. Collaborator C, however, made this adjustment by adding a calculated amount of concentrated ammonium hydroxide. In spite of the satisfactory results submitted by this collaborator, the Associate Referee studied the effect of ammonium salts on the dithizone extraction of mercury. The following experiments were performed. To a solution of 100 ml of 2.0 *N* sulfuric acid and 100 ml of 2.0 *N* nitric acid, 50 ml of 20% ammonium nitrate and 50 ml of 20% ammonium sulfate were added. After the addition of 10 mg of mercury, the solution was diluted to 400 ml with water. The final acidity, established by titration, corresponded to 1.0 *N*. Mercury was then evaluated by the conventional extraction procedure. The recovery was quantitative. In a second experiment, 50 g of comminuted tomatoes, containing 25 mg of added mercury, was digested with 20 ml of a mixture of nitric and sulfuric acids (1 + 1) and nitric acid as needed. At completion of digestion, the volume measured 310 ml and the acidity 2.26 *N*. Twenty-five ml. of concentrated ammonium hydroxide was added to reduce the acidity to 1.0 *N*. A final recovery of exactly 25 mg of mercury was obtained. In a third trial, 100 g of comminuted tomatoes containing 25 mg of

added mercury was digested with mixed acids in the usual manner. After digestion, the volume was again 310 ml and the acidity equivalent to 2.25 *N*. A volume of 25 ml of concentrated ammonium hydroxide was therefore added to reduce the acidity to 1.0 *N*. Again, the eventual recovery of mercury by dithizone extraction was quantitative. Since ammonium salts have no repressive or complexing action on the extraction of mercury, this means of reducing the acidity of the digest, prior to evaluating the metal, will be incorporated in the new set of directions which will be distributed to collaborators during the forthcoming study.

It is recommended* that a study of the two procedures be continued.

REPORT ON PARATHION

By P. A. CLIFFORD (Food and Drug Administration, Federal Security Agency, Washington, D. C.), *Associate Referee*

The colorimetric method of Averell and Norris (1) has become standard procedure for the determination of parathion spray residues. Most analysts follow the original details of the method; however, certain observations and refinements are worthy of mention.

Preparation of standard curves.-As standard material, these authors first used the crystalline parathion-amine hydrochloride as prepared from the technical product by a stannous chloride reduction. Because isolation of the pure amine hydrochloride proved difficult, and because its solutions were unstable, later directions called for use of purified parathion itself. Benzene solutions were evaporated down, reduced in covered beakers, and carried through the procedure as with actual determinations. The Associate Referee noted that standard curves prepared in this way were less steep (less color density at 555-560 $m\mu$ by about 6-8 per cent) than curves prepared directly from equivalent amounts of the pure amine hydrochloride. Apparently most of this loss is in the initial stages of the reduction and does not occur during the evaporation of the benzene; when 5 ml portions of benzene containing 100 micrograms of parathion were evaporated down at room temperature, the residue taken up with 20 ml 1+1 water-EtOH, and reduced by boiling for 5 minutes *under reflux*, close to theoretical color values (as against equivalent amounts of the pure amine) were obtained.

The Associate Referee now uses the following procedure for the preparation of standard colors as well as for the actual determination of parathion in benzene "strips": The benzene aliquot, usually not less than 25 ml, is placed in a 250 ml, standard taper ground-neck Erlenmeyer. Twenty ml of 0.5 *N* hydrochloric acid and about 0.2 g of zinc dust is added, and the flask is connected to a condenser by means of an all-glass adapter

* For report of Subcommittee C and action of the Association, see *This Journal*, 34, 49 (1951).

fitted with a thermometer. The flask is placed upon a bot-plate and the benzene is rapidly distilled (T of vapor = 69-70°C.). Reduction proceeds concurrently with the distillation and no parathion is lost. Ebullition stops after elimination of the benzene, and vapor temperature first falls, then begins to rise. The aqueous solution is not allowed to boil; at this point the flask is removed, 10 ml of 95 per cent alcohol is added and the flask is re-connected to a simple reflux condenser. After a 5 minute reflux, the flask is removed, cooled, and its contents filtered into a 50 ml volumetric flask as usual. If appreciable waxes and/or coloring matters are present in the acid solution it may be decanted into a small separatory funnel and washed, before filtration, with about 10 ml of petroleum ether.

The alcohol appears to stabilize the color, possibly by simply lowering the boiling-point of the reduction mixture, **I**t was noted that prolonged boiling of all-aqueous reduction media or prolonged exposure to steam-bath temperatures of 90-95° caused loss of color strength.

Distillation of the benzene carries off some azeotropic water. For a 25 ml aliquot of the benzene strip the quantity can be ignored, but for 50, 100, and 200 ml aliquots, 4, 8, and 16 ml of water are added to the flask along with the 20 ml of 0.5 N hydrochloric acid.

J. C. Gage (2) uses toluene instead of benzene as a solvent medium and reduces extracted parathion directly by refluxing the toluene with a little acetic acid and zinc dust. The reduced parathion is then extracted from the mixture with dilute hydrochloric acid. Most interferences and extraneous coloring matters are eliminated by this procedure.

Averell and Norris' method is very sensitive. The color produced by only one microgram of parathion is readily apparent when developed in a 50 ml Nessler tube and compared against a reagent blank. The Nessler tube technic has been used by the Associate Referee in the detection of very minute quantities of parathion. However, many analysts employ a Beckman spectrophotometer or similar instrument with cells or test tube cuvettes of only about 1 cm. length. Sensitivity is hereby lost; with the prescribed standard colorimetric volume of 50 ml, color density for 100 micrograms of parathion through a 1 cm cell is only about .33 (about 46 per cent transmittance). For more precise results with smaller amounts of parathion the use of longer cells and more restricted standard ranges is urged.

Purification of Benzene.-Benzene is commonly used in the solvent method of sample preparation. The resulting "strip solutions" are then clarified with certain combinations of adsorbents. Impure benzene may contribute an interfering color similar to that produced by parathion. Edwards (3) removes such interference from solvent benzene by distillation, Gunther and Blinn (4) by means of an acid wash. Whichever procedure is used, possibility of trouble from this source must be kept in mind.

Natural "Blanks."-Theoretically, any aromatic amine or nitro compound will give an azo color approximating, or identical with, the parathion color. Hence the procedure is by no means specific for parathion. It has been noted that many plant materials, especially certain leafy vegetables, give a positive final color even when parathion is known to be absent. Tobacco, especially, yields a high "blank"; the Associate Referee has obtained interfering color equivalent to 1.5-2.0 p.p.m. parathion on leaf from the 1937 crop. Fortunately, many food materials, especially fruits such as apples, pears, and peaches, can be handled without trouble. These fruits can be given a surface wash with benzene in the conventional churn-type washer and small aliquots of the wash solution represent substantial weights of sample without in themselves being unduly contaminated with waxes and coloring matter. The problem is not so simple when green leafy material is minced or "blended" with benzene; here, much more extraneous material is included in the strip.

Failing means to eliminate these natural interferences, most analysts prepare a "blank" color by carrying a similar quantity of untreated material through the entire procedure. Then, with suspect samples, any pink color in excess of that which develops in the "blank" is taken to be parathion. Such practice points up the greatest weakness of the procedure. Comparable blank material may be unavailable or may give variable blank colors; the analyst may report traces of parathion when it is entirely absent or, conversely, may not detect actual small residues. Specificity is the prime requirement of a good method and it is feared that the Averell and Norris procedure will not be wholly acceptable to regulatory chemists until means are found of eliminating, or minimizing, these natural color interferences.

During the past year, the writer has made but scant progress in this direction. He was unable to eliminate the color interference from tobacco strips by the use of various combinations of adsorbents. Acid washing of decolorized strips did not help and this may indicate that some interfering materials are not aminic in character. An effort to isolate parathion from interfering residues by an evaporation technic may be worthy of description: a retort (a 250 ml ground-neck Erlenmeyer flask) was placed inside a small hot-air oven. By means of all-glass connections, dried air at a pressure of about 2 mm mercury was drawn through the retort and into a collecting tube immersed in a dry ice-acetone mixture. Pure parathion volatilized readily at temperatures below 100°C. and could be collected quantitatively, but its evaporation was greatly repressed by the natural plant waxes. When known quantities of parathion were added to the residues of strip solutions of parathion-free plant material, prolonged aspiration (4-5 hrs; retort temps. up to 120°C.) gave variable returns, usually in the neighborhood of 50 per cent, and this method of isolation was abandoned.

Because feasible means of minimizing these natural blanks were not found, collaborative samples were not distributed during the past year. The Associate Referee intends next to try a chromatographic purification of either the benzene strips or of the reduced parathion. Possible refinements will be evaluated and it is hoped that these can be incorporated into a procedure worthy of collaborative trial during the coming year.

It is recommended* that work on parathion be continued.

REFERENCES

- (1) *Anal. Chem.*, 20, 753 (1948).
- (2) *Analyst*, 75, 189 (1950).
- (3) *Anal. Chem.*, 21, 1415 (1949).
- (4) *Advances in Chemistry Series*, No. 1, 72 (1950).

REPORT ON SODIUM FLUOROACETATE (1080)

By L. L. RAMSEY (Division of Food, Food and Drug Administration, Federal Security Agency, Washington, D. C.), *Associate Referee*

No improvements have been made in the quantitative method for 1080 which was studied collaboratively last year.¹ However, this method has been used recently in a study of the absorption, distribution, and excretion of 1080 in rats.² Also, during the current year a method employing a buffered chromatographic column has been developed to separate mono-fluoroacetic acid from acetic, di-, and tri-fluoroacetic acids, as well as from other fluorine-containing acids. A description of this technic was given in a contributed paper last year (*This Journal*, 33, 1010 (1950)).

A qualitative test for 1080, which would be more sensitive and less subject to interferences in the extracts of foods and biological materials than the indigo test of Wilson, is badly needed. It was suggested by W. I. Patterson of this Division that thioindigo be used as a basis for such a test. Some work has been done along this line. On the basis of preliminary experiments it appears that this approach to the problem does hold some promise.

RECOMMENDATIONS†

(1) It is recommended that study of the quantitative method for 1080 be continued for the purpose of improving its accuracy.

(2) It is further recommended that work be continued on a qualitative test for 1080.

* For report of Subcommittee C and action of the Association, see *This Journal*, 34, 49 (1951).

¹ RAMSEY, L. L., and CLIFFORD, P. A., *This Journal*, 33, 608 (1950).

² HAGAN, E. C., RAMSEY, L. L., and WOODWARD, GEOFFREY, *J. Pharmacol. and Exptl. Therap.*, 99, 432 (1950).

† For report of Subcommittee C and action of the Association, see *This Journal*, 34, 49 (1951).

REPORT ON METHOXYCHLOR

THE SEPARATION OF DDT AND METHOXYCHLOR AND THE
ANALYTICAL DETERMINATION OF EACH COMPONENT

By FRIEDA M. KUNZE and EDWIN P. LAUG, *Associate Referee* (Division of Pharmacology, Food and Drug Administration, Federal Security Agency, Washington, D. C.)

The separation of DDT and methoxychlor and the determination of each component, particularly when fatty residues are involved, presents an analytical problem. There are a number of methods based on the Schechter procedure (1) for determining DDT. These differ chiefly in the manner by which removal of interfering fat is effected. Clifford (2) removes fat by enzymatic hydrolysis; Davidow (3) by chromatography; Prickett *et al.* (4) by mineral hydrolysis. No one of the methods listed is applicable to both the separation and individual determination of each component of a DDT-methoxychlor mixture. Davidow's method (3) quantitatively separates DDT and methoxychlor. Methoxychlor and fat are held on the sulfuric acid-celite column, while DDT percolates through. Efforts to elute the methoxychlor portion, however, have been unsuccessful. By all other methods, the effect of a DDT and methoxychlor mixture would be additive. Since the color intensities of nitrated DDT and methoxychlor differ, and since the absorption maxima of DDT is 520 $m\mu$ and methoxychlor is 530 $m\mu$, differentiation by equation is not feasible. Fortunately, the Fairing and Warrington method (5) for determining methoxychlor is specific for methoxychlor. The red color complex produced by the addition of 85% sulfuric acid to dehydrohalogenated methoxychlor is unaffected by the presence of DDT; however, if the sample contains unsaponifiable residues or carotenoid material, sulfuric acid treatment results in char and brown discoloration. The method suggested by Fairing for avoiding such interference has not been successful in our hands. Consequently, we have introduced a chromatographic step to avoid char.

The method proposed effects quantitative separation of DDT and methoxychlor mixtures. If both DDT and methoxychlor are present in the sample, and the determination of each component is desired, analyses must be made on separate aliquots.

PROPOSED METHOD

APPARATUS

- (1) *Chromatographic tubes.*-10 mm O.D. X 130 mm long.
- (2) (All other apparatus is specified in the method selected).

REAGENTS

- (1) *Celite 545.*-Johns Manville.
- (2) *Absorptive powdered magnesia.*-fine.
- (3) *Commercial normal hexane.*-redistilled.
- (4) All other reagents are specified in the method selected.

DETERMINATION OF DDT IN THE PRESENCE OF METHOXYCHLOR

Proceed with the separation of DDT and methoxychlor by Davidow's chromatographic method for the isolation of DDT from fat (3). Collect the CCl₄ eluate; evaporate to dryness at room temp. with an air current. Nitrate and develop color by the standard Schechter procedure.

Chromatograph on the celite-H₂SO₄ column a series of 0-5-10-15-25-30 and 50 mmg of DDT in the presence of 1000 mmg of methoxychlor and 5 g of lard, (DDT recovery averages 100%. The range of error is 2%).

DETERMINATION OF METHOXYCHLOR IN THE PRESENCE OF DDT

Since neither DDT nor its dehydrochloride yields a red color when treated with sulfuric acid, no separation of the mixture is necessary if the determination of methoxychlor only is desired. Follow the hydrolysis and extraction procedure as outlined by Prickett *et al.* (4). One petroleum ether extraction and one alcoholic wash is adequate. Evaporate the hydrolysate to dryness at room temp. with an air current and chromatograph as follows:

CHROMATOGRAPHY

Place a small plug of glass wool in the bottom of the chromatographic tube. Add 1.5 g of a 1:1 celite 545 and absorptive powdered magnesia mixture to the tube and pack by gentle air suction. Moisten the column with 5-10 ml hexane. Discard the rinsings. Dissolve the hydrolysate residue and the dehydrohalogenated methoxychlor in 25 ml hexane by successive additions of small portions of hexane, and chromatograph. (Gentle air suction is required.) Evaporate the hexane to dryness at room temp. with an air current and proceed with color development.

COLOR DEVELOPMENT

Develop the color with 10 ml of 85% sulfuric acid as outlined by Fairing (5). Stopper the flasks with a glass stopper, shake frequently, and allow a minimum of 30 min. before measuring color density on a suitable instrument. The colors are stable. Readings checked after a three-hour interval were identical.

PREPARATION OF STANDARDS

(In the 0-50 mmg range)

Hydrolyze and process the standards in the manner described above. Chromatography is not necessary. Read at 550 m μ against 85% sulfuric acid. Plot the relationship between concentration and density. (Daily checks of standards are not necessary. The standard slopes obtained with 85% sulfuric acid stored in a pyrex bottle stoppered with an automatic burette varied less than 1% after a month.)

LIMITATIONS OF THE METHOD

Methoxychlor analyses have been made on only a limited number of materials: rat fat, rat liver, lard, butter, and apple wax. Methoxychlor recovery from rat fat and lard is quantitative; the range of error is 2 to 3 per cent. The slopes obtained by plotting density against concentration for methoxychlor added to liver, butter, and apple wax, however, are not identical with the standard slope. There is a straight line relationship between points and the range of error is small, but referred to the standard slope, methoxychlor recoveries from liver averaged 104 per cent recoveries from butter, when chromatographed once, averaged 69 per cent; when

chromatographed twice, 84 per cent. Apple wax is not held on the magnesium oxide-celite column, and recoveries of methoxychlor were poor. Preliminary work shows that variation of slopes for different materials necessitates the addition of control background strippings to the standards and the calculation of the unknown by difference. Obviously, this is an undesirable step, and further investigation on the construction of more efficient chromatograph columns is indicated.

BIBLIOGRAPHY

- (1) SCHECHTER, M. Š., POGORELSKIN, M. A., and HALLER, H. L., *Ind. Eng. Chem., Anal. Ed.*, 19,51 (1947).
- (2) CLIFFORD, P. A., *This Journal*, 30, 339 (1947).
- (3) DAVIDOW, B., *Ibid.*, 33, 130 (1950).
- (4) PRICKETT, C. S., KUNZE, F. M., and LAUG, E. P., *Ibid.*, 33, 880 (1950).
- (5) FAIRING, J. D., WARRINGTON, JR., H. P., *Advances in Chemistry Series*, No.1, 260, A.C.S. (1950).

The contributed paper by L. L. Ramsey, entitled Separation of Acetic, Monofluoroacetic, Difluoroacetic, and Trifluoroacetic Acids, by Partition Chromatography," was published in *This Journal*, 33, 1010 (1950).

No reports were given for copper and zinc; DDT as spray residue on foods; or insecticides in canned foods.

REPORT ON ENZYMES

By J. W. COOK (Food and Drug Administration, Federal Security Agency, San Francisco, California), *Referee*

The chapter on Enzymes in the 7th edition of *Methods of Analysis, A.a.A.C.* contains four enzyme methods. It differs from the earlier editions in that the methods employing enzymes were placed in the chapter for the product on which the method was used. These methods, as well as some others, involve a quantitative determination of enzyme activity, whereas some methods in the book employ enzymes only as reagents. All procedures involving enzymes are grouped in Table 1, and those which are to be in the enzyme chapter in the 7th edition are marked with an asterisk.

The marked interest in the enzyme field, as demonstrated by the large number of papers on enzymes appearing in current journals, suggests that we may be using this analytical tool to much greater extent in the future. It will be my purpose to keep informed on this literature and to recommend studies to the Association for potential procedures. I shall appreciate information and suggestions from anyone interested in the development of new methods.

Some procedures which may hold promise for our development include the use of a catalase test for mold. A qualitative test was originally used by Chace and Church (U.S.D.A. Technical Bulletin No. 1, Oct., 1927) to test for moldy raisins and was later adapted by Doris H. Tilden of this laboratory to test for moldy salt and brine-cured ripe olives. It has also been used for detection of moldy black pepper berries. The test is based on the disproportionate amount of catalase produced in moldy fruit as

TABLE I.-A.O.A.C. Methods Involving Enzymes

	<i>6th Edition</i>
A. Quantitative assay of enzyme activity.	
(1) Measure of quality of product.	
*(a) Proteolytic Activity of Papain	(5.1)
*(b) Diastase Activity of Flour	(20.61)
(c) Diastase Power of Malt	(14.61)
(d) Diastase Power of Malt Syrups	(14.94)
(e) Diastase in Honey	(34.106)
*(0) Proteolytic Value of Flour (1949 Changes in Methods)	
(2) Residual enzyme as a test of a processing step.	
*(a) Catalase in Frozen Foods (1947 Changes in Methods)	
(b) Phosphatase Tests for Pasteurization	
B. Enzyme as reagent in analytical procedure.	
(a) Diastase method for starch in:	
(1) Coffee	(18.17)
(2) Cocoa Bean and Its Products	(19.46)
(3) Grain and Stock Feed	(27.34)
(4) Spices	(33.14)
(5) Confectionery	(34.78)
(b) Urease Test for Urea	
(1) Grain and Stock Feeds	(27.22)
(2) Urine Stains in Cloth	(42.98)
(c) Invertase for Sucrose	(34.22)
(d) Invertase-melebiase for Sucrose and Raffinose	(34.25)
(e) Cocarboxylase for Thiamine	(36.24)
(0) Pancreatin for Filth	(42.2)

* Asterisks indicate the sections which appear in the Enzyme chapter of the 7th Edition.

compared to normal fruit. It has served well as a sorting procedure and could possibly be developed into a general method.

Balls¹ reported that the enzyme content of frozen eggs was dependent upon the time held in cold storage. This may be a clue to a procedure for the detection of decomposition in frozen eggs, frozen fish, berries, etc. which have not been heat treated.

For some time the Referee has been interested in the development of a method for the detection of rodent feces in food products based on the

¹ *Ind. Eng. Chem.*, 26, 570 (1943).

a second sample for 4 hours, a third sample for 8 hours, etc. There seemed to be a continuous increase in extracted oil up to 16 hours after which there was an apparent decline in the quantity of oil. The 32 hour extraction was repeated and the decline of oil found was confirmed. It is assumed that the long heating of the oil-acetone solution caused sufficient hydrolysis of the oil to result in this decreased value. Accordingly, in subsequent series the same sample of fish meal was subjected to a series of extractions with acetone, removing the acetone-oil solution from the meal after each period and continuing the refluxing with fresh acetone. Following this procedure the results shown in Table 2 were obtained. In this case no

TABLE 1.-Unpurified acetone extractives⁸ obtained by refluxing herring meal with 80 solvent

REFLUX TIME	Gft088 EXTRACT
hours	per cent
2	13.51
4	14.13
8	15.04
16	16.29
32	14.97
32	14.83

decline in extracted oil takes place; rather, there is a slow increase as the extraction period is extended.

Table 3 shows results when acetone containing hydrochloric acid (99 volumes acetone and 1 volume 12*N* hydrochloric acid) was employed. A much more rapid extraction of crude oil is obtained when hydrochloric acid is present, but not all the extractives obtained are soluble in ethyl ether as the data in the right hand side of the table under purified extraction shows.

Another series of tests similar to that shown in Table 3 was carried out but using shorter initial refluxing periods (Table 4). These data show that well over half the oil is extracted within the first minute of refluxing.

Trials are being continued to test this method more thoroughly with regard to a number of points. The best ratio of sample to solvent is being investigated. Since hydrochloric acid when present in the acetone solvent causes extraction of considerable material other than ethyl ether soluble fat, the possibility of using weaker acids such as acetic is being looked into. After a method is developed which can be adopted, it will be necessary to compare results obtained by it with the A.O.A.C. acetone extraction procedure.

It is, therefore, recommended* that work on fat in fish meal be continued.

* For report of Subcommittee A and action of the Association, see *This Journal*, 34, 40 (1951).

TABLE 2.—Extraction of oil from herring fish meal by refluxing with acetone

NO.	TIME FOR PARTICULAR REFLUX PERIOD	GROSS ACETONE EXTRACT						PURIFIED EXTRACT					
		QUANTITY OIL EXTRACTED			ACCUMULATED TOTALS			QUANTITY OIL EXTRACTED			ACCUMULATED TOTALS		
		SAMPLE NUMBER			TIME	AVERAGE OIL EXTRACTED	hours	SAMPLE NUMBER			TIME	AVERAGE OIL EXTRACTED	hours
		1	2	3	per cent	per cent		per cent	per cent	per cent	per cent		
1	1	12.75	12.35	12.70	12.60	1	12.60	12.71	12.37	12.72	12.60	1	12.60
2	3	0.84	1.05	1.18	1.02	4	13.62	0.61	0.94	1.07	0.87	4	13.47
3	3	0.47	0.83	0.42	0.57	7	14.19	0.32	0.67	0.41	0.47	7	13.94
4	16	0.79	0.73	1.06	0.86	23	15.05	0.45	0.45	0.51	0.47	23	14.41
Totals	23	14.85	14.96	15.36	15.05	23	—	14.09	14.43	14.71	14.41	23	—

TABLE 3.—Extraction of oil from herring fish meal by refluxing with acetone containing 1% concentrated hydrochloric acid by volume

NO.	TIME FOR PARTICULAR REFLUX PERIOD	GROSS ACETONE EXTRACT						PURIFIED EXTRACT					
		QUANTITY OIL EXTRACTED			ACCUMULATED TOTALS			QUANTITY OIL EXTRACTED			ACCUMULATED TOTALS		
		SAMPLE NUMBER			TIME	AVERAGE OIL EXTRACTED	hours	SAMPLE NUMBER			TIME	AVERAGE OIL EXTRACTED	hours
		1	2	3	per cent	per cent		per cent	per cent	per cent	per cent		
1	1	17.54	17.70	18.26	17.83	1	17.83	14.78	14.94	14.91	14.88	1	14.88
2	3	4.55	4.27	5.46	4.76	4	22.59	1.34	1.17	1.68	1.40	4	16.28
3	3	3.20	3.40	4.00	3.50	7	26.09	0.94	1.13	1.61	1.23	7	17.51
4	16	4.40	4.60	5.14	4.71	23	30.80	1.80	1.57	1.65	1.67	23	19.18
Totals	23	29.69	29.97	32.86	30.80	23	—	18.86	18.81	19.85	19.18	23	—

TABLE 4.—Extraction of oil from herring fish meal by refluxing with acetone containing 1% concentrated hydrochloric acid by volume

NO.	TIME FOR PARTICULAR REFUX PERIOD	GROSS ACETONE EXTRACT						PURIFIED EXTRACT				
		QUANTITY OIL EXTRACTED			ACCUMULATIVE TOTALS			QUANTITY OIL EXTRACTED			ACCUMULATIVE TOTALS	
		SAMPLE NUMBER			AVERAGE			SAMPLE NUMBER			AVERAGE	
		1	2	3	per cent	per cent	per cent	min.	per cent	per cent	per cent	min.
1	1	15.08	15.14	15.35	15.19	1	13.00	12.90	12.70	12.87	1	12.87
2	1	3.17	2.87	3.03	3.03	2	1.56	1.32	1.40	1.43	2	14.30
3	3	1.59	1.42	1.57	1.53	5	0.39	0.31	0.35	0.35	5	14.65
4	5	1.18	0.93	1.22	1.11	10	0.27	0.26	0.38	0.30	10	14.95
5	10	0.91	0.95	1.09	0.98	20	0.25	0.25	0.31	0.27	20	15.22
6	40	1.28	1.36	1.18	1.27	60	0.36	0.37	0.33	0.35	60	15.57
7	960	2.69	3.74	4.36	3.60	1020	1.25	2.02	2.19	1.82	1020	17.39
Totals	—	25.90	26.41	27.80	26.71	1020	17.08	17.43	17.66	17.39	1020	—

Acknowledgement is made to Mr. William Clegg, Chemist, Fish and Wildlife Service, Seattle, who carried out many of the analyses in this report.

REPORT ON MICROSCOPIC ANALYSIS

By J. A. SHRADER (Kentucky Agricultural Experiment Station, Lexington, Ky.), *Associate Referee*

It was brought out last year in my report¹ that several things needed to be done in the field of microscopic analysis.

It can be reported that considerable progress has been made on point 6 (*loc. cit.*), which had to do with improvement in the method of reporting the results of our analysis to the manufacturer. It was stated last year that when a feed is found to be out of line with the guaranteed list of ingredients, especially as regards unground weed seeds, etc., the manufacturer not only is told what is wrong, the fact is demonstrated by an enlarged picture of the feed in question. This method, using direct positive photographic paper, was simple and quick—a 5X7 enlargement (20X) could be made directly from the sample. The time required was approximately 15 minutes from the time the sample was placed under the camera until the picture was finished and ready to go. The finished picture in this case was in black and white.

It was also reported that experiments were being made with a process whereby the pictures could be made in color at a cost which would not be prohibitive.

During the past year the black and white pictures have been practically discarded in favor of the colored ones. Color is so far superior to black and white for this type of work that there is no comparison. The fact that all of the particles of feed are shown in their natural color makes it very simple to point out all of the factors of the feed ingredients that are not as guaranteed. One sample of cracked corn was contaminated with a green mold. It would have been hard to show this with the black and white photographic paper. On the color print it appeared just as we saw it under the microscope. The cost of each 5X7 color picture is approximately 35 cents.

PROCEDURE

There are three phases of color-picture development that must be constant in order to obtain uniform pictures.

First, source of light: color film is balanced for light of 3200° Kelvin. An ordinary house lamp of 100W is 3000° Kelvin. This is too low and will cause the red layer in the film to predominate so the picture will have an over-all red color. Direct sunlight is rated at 4500° Kelvin and will cause the resulting picture to be blue. Special photo flood lamps may

¹ *This Journal*, 33, 149 (1950).

be obtained which radiate 3200° Kelvin for about \$1.60 each. We are using at present two 500 watt Tungsten (T-20) projection bulbs which also are rated at 3200° Kelvin.

It must also be remembered at this point that the voltage which operates the light must be fairly constant. There had been considerable trouble, until we discovered the cause, with an uneven source of current. Sometimes the pictures would be blue and sometimes red. It was found that our electric line varied from 115 volts up to 127 volts. Installation of a voltmeter and a rheostat, made it possible to regulate the voltage at 115 volts before each picture, eliminating this trouble. A constant voltage transformer would be desirable, but not absolutely necessary. A variation of only 2 or 3 volts will not affect the picture enough to be noticed.

The second phase that must be constant in developing the picture is the temperature of the developing baths. The formulas are set up for 68°F. or 20°C. Adjustments in developing time may be made for higher or lower temperatures but it is very desirable, for uniform results, that the development be carried out at 68°F. Especially, the first developer and the color developer solutions should be held at 68°F. This can be done by using a constant temperature water cooler such as was used by the army in the Pacific for photographic work. If an air-conditioned room is available all the developing can be carried on without the water bath. The use of ice is not too satisfactory because of the difficulty in maintaining a constant temperature.

The third phase which was found to be important is constant agitation of the films in the solutions. The pictures should be lowered into the developing solutions and raised out of the solutions 20 to 30 times per minute. Whatever figure is determined upon (20-24-27, etc.) it should be used for each development. When the films were raised and lowered manually, it was very difficult to maintain this operation at a constant rate. On days when the analyst was tired operations were slow; on other days, faster. The faster speed gave a little more development and tended to throw off the color balance. This trouble was eliminated by use of an electric motor with reduction gear attached to a rack for raising and lowering the film into the solutions at a uniform rate.

The combination of constant source of illuminating light, constant temperature of the developing baths, and constant agitation will enable any worker to obtain satisfactory color prints almost without fail.

The medium used for making the color pictures is Ansco "Printon." This may be obtained in a variety of sizes from 4"X5" up and is essentially similar in principle to Ansco color film which is used in ordinary cameras for color transparencies. The difference is that the three color emulsion layers are thinner and they are coated on a white opaque cellulose acetate base. The picture is viewed by reflected light from this white base.

Ordinarily, Printon is used to make prints or enlargements from color transparencies. In our work, however, no transparency is made. The Printon is placed in the camera film holders and the exposure made directly on it as in the case of the black and white direct positive process. The fact that the image is reversed does not detract from the finished picture.

The camera used is the same as that shown in last year's report (*This Journal*, 33, 149 (1950)). The only change has been in the illuminating light and the addition of a filter cap over the lens of the camera. Each package of Printon comes with a recommended filter compensating combination. A set of gelatin filters is obtainable to correct for minor variations in the color balance of the particular Printon emulsion in use. Once the variations are corrected with the compensating filters, it becomes practically a constant requiring very little attention. The slight differences in the color temperature of the illuminating systems used by other laboratories can also be corrected by the use of these gelatin compensating filters. One or more of the filter combinations may have to be added or subtracted to secure the optimum balance of color. If it is found, for instance, that it requires not only the recommended filters but an additional yellow 24 to secure correct color rendition, then the yellow 24 gelatin filter may be considered a necessary part of the filter set-up and used from then on until the box of Printon is used up. Printon may be purchased a gross at a time, so that the adjustments that have to be made for different Printon emulsions are greatly minimized. Recent improvements in the manufacture of Printon have practically eliminated the variations in emulsions which previously caused some trouble in development.

The exposure time for this laboratory is 4 seconds with the iris closed to F22.

DEVELOPMENT

Six different solutions are required in the development of the color pictures. These may be obtained in the form of a kit from the Ansco Company. The Ansco Company will also provide the formula for each solution so that the worker can compound them. The latter is the most satisfactory and the least costly method. Also, by varying the amounts of some of the ingredients in the formula it is possible to obtain a more satisfactory balance of color.

The time required for complete development is 90 minutes. The first 14 minutes is the only time requiring complete darkness. The rest of the procedure is carried on with the lights on. Four or more pictures can be developed at one time, which makes the time for individual pictures about the same as for the black and white pictures.

Morgan and Lester's "Leica Manual" contains a chapter on Ansco Color film and Printon which was very helpful in developing this process.

The Ansco Corporation also published a booklet "Color Photography Made Easy," which contains many suggestions.

This method of reporting findings to the manufacturer has been used in Kentucky long enough to know that it obtains good results. Any control official who wishes to adopt this system of reporting samples can depend on our assistance in every way possible.

REPORT ON CRUDE FIBER

By WILLIAM L. HUNTER (State Department of Agriculture, Sacramento 14, California), *Associate Referee*

This report is a continuation of the study of methods for determination of Crude Fiber, which was undertaken with the purpose of either improving, supplementing, or replacing the present official method. On successive years studies have been made of the procedures followed in laboratories making this analysis; the effect of differences in technique upon the results obtained; a review of the literature for methods possessing advantages over the present, and a collaborative study of a method employing stronger reagents for a shorter period of time. The 1949 study indicated a definite interest in the time saving possibilities of the short method and demonstrated its ability to produce results comparable to the official method.

The 1950 project has consisted of an enlarged collaborative study including all subscribers to Collaborative Check Sample, Series A of the Association of American Feed Control Officials. A sample of dairy feed was tested by both official and short methods. Collaborators were polled on their experiences with the method.

The data obtained are too voluminous for inclusion in this report, but study of it indicates confirmation of the favorable findings in last year's work. The short method will apparently produce results not significantly different from those obtained with the official method. The method under trial did not fare well in acceptancy by those using it. A minority of those reporting found a definite time saving under the condition in their laboratories. Those who once had problems of time and volume requirements have apparently solved them satisfactorily by use of mechanical conveniences.

ACKNOWLEDGMENTS

The Associate Referee is very appreciative of the cooperation extended by the Collaborative Check Sample Committee of the Association of American Feed Control Officials and the several subscribing laboratories.

It is recommended* that study of the Crude Fiber method be discontinued.

* For report of Subcommittee A and action of the Association, see *This Journal*, 34, 40 (1951).

REPORT ON CRUDE FAT OR ETHER EXTRACT

By HAROLD H. HOFFMAN (Florida Department of Agriculture, Tallahassee, Florida), *Associate Referee*

During 1949 this Associate Referee indirectly received correspondence from some feed control officials suggesting that the official method for crude fat might be editorially changed to permit an alternate method. Essentially this alternate embodied a faster solvent flow to compensate for a time reduction to four hours.

Previous collaborative work on comparing these methods has been reported as follows: In 1933,¹ L. S. Walker stated that the three hour high-heat method gave identical results with those obtained by the official method. In 1934² he reported that from 200 tests run on 27 different feeding stuffs an average of only 0.04% more ether extract was obtained by the official method than by the four hour high-heat method. In 1941, J. J. Taylor³ recommended that the four hour high-heat method should not be given any official status. Thirteen collaborators analyzing six samples each found an average of 0.14% less ether extract than they obtained on the same samples by the official method.

This year's work was planned with the hope that comparative results on the two methods might be obtained on a large number of samples with a minimum of interference to the laboratories participating.

No samples were sent out but each collaborator was asked to make four hour extractions on as many as possible of the routine feed samples on which he would be determining the crude fat by the official method. More porous thimbles were to be used, if necessary, for the four-hour extraction to accommodate the greater solvent flow rate. For each method the preliminary removal of moisture and the ethyl ether used were to be similar. Of the six collaborators only three found it possible to participate. A summary of these three reports follows:

TABLE I.-Average ether extract

COLL.	TYPE FEED	NUMBER SAMPLES	OFFICIAL METHOD	4-HOUR METHOD	DIFFERENCE
			<i>per cent</i>	<i>per cent</i>	<i>per cent</i>
A	Prepared cereals	5	3.26	3.18	0.08
B	Mixed	12	3.64	3.64	0.00
C	Dairy and cattle	125	3.76	3.52	0.24
	Poultry and turkey	138	3.91	3.68	0.23
	Swine	19	4.33	4.12	0.21
	Horse and mule	27	3.53	3.37	0.16
	Oil seed meals	19	5.46	5.20	0.26
	Citrus by-products	30	6.25	6.03	0.22
	Dog foods (dry basis)	14	7.59	7.37	0.22
	Miscellaneous	49	3.76	3.51	0.25

¹ *This Journal*, 16, 190 (1933).

² *Ibid.*, 17, 185 (1934).

³ *Ibid.*, 25, 867 (1942).

Collaborator A made at least quadruplicate determinations by each method on each of five samples. He used the old pickle type extractor and doubled the solvent flow for the four-hour method by increasing the heat. He found the RA 360 alundum crucible inadequate for the rapid method and resorted to the RA 98.

Collaborator B used a homemade Soxhlet type extractor for eight hours as an official method. For the rapid method a Goldfish Extractor was used.

Collaborator C used the Goldfish Extractor at low heat for the official method and the same apparatus at high heat for the four-hour method. RA 98 alundum crucibles were used for both methods. For the most part only single determinations were made by each method. When two or more determinations were made a figure representing the average was used.

The Associate Referee is disappointed not to have received a larger volume of comparative data upon which to base his conclusion. Collaborator C reported on 421 samples and found a small but definite difference-0.23 per cent on the average-in results by the two methods. Collaborators A and B found little and no difference, respectively, but only 17 samples were represented.

It is believed that the four hour high-heat method may be of considerable value in many laboratories for unofficial use. However, until more collaborative data are presented to establish that values by this method will be identical with those of the official method it is recommended that this rapid method should not be made first action.*

The following is a list of collaborators (The order has no bearing on the letter designations used above):

- M. P. Etheredge, State College, Mississippi
- M. H. Neustadt, U. S. Department of Agriculture, Beltsville, Maryland
- Marvin Van Wormer, Farm Bureau Cooperative Assn, Columbus, Ohio
- John B. Smith, R. I. Experiment Station, Kingston, Rhode Island
- Deland H. Davis, General Foods Corporation, Battle Creek, Michigan
- J. C. Edwards and M. M. Trowbridge, Florida Dept. of Agriculture, Tallahassee, Fla.

REPORT ON SULFA DRUGS IN FEEDS

By RICHARD T. MERWIN (Agricultural Experiment Station, New Haven, Conn.), *Associate Referee*

Last year's collaborative study, reported in *This Journal*, **33**, 156 (1950), resulted in the adoption, first action, of a method for sulfaquinoxaline. The Association then approved a recommendation that a method be developed for sulfaguanidine; and this report presents the results of the collaborative work on such a method.

* For report of Subcommittee A and action of the Association. see *This Journal* **34**, 40 (1951).

Although sulfaguanidine predates sulfaquinoxaline as an anticoccidial, it is not so generally used as the latter. Moreover, it is prescribed in greater concentration, from 0.50 to 1.00 per cent, against sudden outbreaks of cecal and intestinal coccidiosis in poultry, instead of being used as a prophylactic, as is sulfaquinoxaline.

Because the sulfonamide drugs may readily be diazotized and coupled with N-(1-naphthyl)-ethylenediamine dihydrochloride to produce colors which can be measured by a spectrophotometer, the method for sulfaquinoxaline, which depends on color formation, was adapted to the assay of sulfaguanidine for this year's study. No changes were made in the method except for sample weight and dilution, because the Associate Referee believes that a general method is desirable for all the sulfa drugs likely to be encountered in feeds.

In fact, use of such a general method for assaying sulfamethazine, sulfamerazine, and sulfathiazole has proved satisfactory in preliminary trials by the Associate Referee. But no collaborative work has been undertaken on these three sulfonamides because they have been used mostly for experimental therapeutics only, and they have been largely supplanted by later types of anticoccidials.

These later types include nitrophenide® (dinitrodiphenyldisulfide) and enheptin® (2-amino-5-nitrothiazole), for which methods have not been collaboratively studied. It is planned to make them the subject of next year's Referee report, as well as to shorten the general method for the two sulfonamides studied thus far.

Experimental work by the Associate Referee has shown that the present general method may be shortened by carrying out the extraction of the drug and the precipitation of the feed protein in the same flask and using only one filtration. This obviously saves time in the routine determination of poultry feeds. However, a few early difficulties were encountered in shortening the method and they were not resolved in time for collaborative study this year. Therefore, the method presented for sulfaguanidine is the same as that for sulfaquinoxaline, without changes except for those mentioned heretofore.

COLLABORATIVE METHOD FOR SULFAGUANIDINE

REAGENTS

- 0.50 *N* NaOH
- 0.50 *N* HCl
- 1.00 per cent soln of ZnSO₄·7H₂O.
- 0.10 per cent soln of NaNO₂. (Prepared fresh each day).
- 0.50 per cent soln of ammonium sulfamate.
- 0.10 per cent soln of N-(1-naphthyl)-ethylenediamine dihydrochloride. (Store in amber-colored bottle.)

DETERMINATION

Weigh 1 g of ground sample into 250 ml flask and add 100 ml of H₂O and 2.5 ml of 0.50 *N* NaOH. Heat in a water bath 15 min. with occasional swirling, cool,

make to volume, and mix well. Let material settle and pipet 25 ml into 100 ml flask, add 10 ml of the $ZnSO_4$ soln, dilute to mark, mix well, and let stand one min. before filtering thru 18.5 cm. Whatman No. 2 paper. Discard first 10 ml of filtrate. (Filtrate *must* be free of turbidity.)

Pipet 2 ml of clear filtrate into 25 ml volumetric flask, add 2.5 ml of the 0.50 *N* HCl and 2 ml of the $NaNO_2$ soln. Let stand 3 min. Add 2 ml of the ammonium sulfamate soln and wait an additional 2 min. Finally add 2 ml of the coupling reagent and dilute to mark. Swirl contents of flask after each addition of reagent. Prepare blank using H_2O and same quantities of reagents made to volume of 25 ml. Shake vigorously.

Measure optical density of colored soln in spectrophotometer at wave length of 545 $m\mu$ against the reagent blank, and determine quantity of sulfaguanidine present by reference to standard curve.

PREPARATION OF STANDARD CURVE

Dissolve 0.010 g of pure sulfaguanidine in 2.5 ml of 0.50 *N* NaOH and 100 ml of H_2O in a 250 ml volumetric flask, by heating in boiling water bath 15 min. Cool and make to volume with H_2O . Transfer 25 ml of this soln to 100 ml volumetric flask, add 10 ml of the $ZnSO_4$ soln, dilute to volume, and filter. Each ml of filtrate contains 10 micrograms of sulfaguanidine. Dilute 1, 2, 3, and 4 ml portions of this filtrate (corresponding to respectively 10, 20, 30, and 40 micrograms of sulfaguanidine), separately to 10 ml with H_2O and treat each soln with 0.50 *N* HCl, 0.10 per cent $NaNO_2$ soln, etc., as directed under the method. Measure optical densities of final solns against reagent blank, and plot density readings against micrograms of sulfaguanidine.

One sample of ground poultry feed containing 1.00 per cent sulfaguani-

TABLE 1.—Analyses of feeds containing Sulfaguanidine

COLLABORATOR	SULFAGUANIDINE, PER CENT			COLLABORATOR	SULFAGUANIDINE, PER CENT		
	PRESENT	FOUND	AVERAGES		PRESENT	FOUND	AVERAGES
1	1.00	1.02	1.02	5	0.96	0.97	
		1.02			0.96		
		1.02			0.98		
		1.02			0.98		
2		0.95	0.96	6	0.97	0.98	
		0.95			0.97		
		0.95			0.98		
		0.97			1.00		
3		0.86	0.86	7	1.00	1.00	
		0.86			0.99		
		0.85			1.01		
		0.86			1.01		
4		0.93	0.96	Average of all			
		0.99		(omitting No. 3)			
		0.94		0.98			
		0.98					

dine was sent to each collaborator with a copy of the method. Each collaborator also received a few grams of pure recrystallized sulfaguandine for preparing standards. Collaborators were asked to submit four results, and these are presented in Table 1.

COMMENTS OF COLLABORATORS

None of the collaborators experienced difficulty in using the method and the lack of any unfavorable comment can be considered as unreserved approval of its precision. This is evidenced by the excellent agreement between quadruplicate determinations of individual collaborators and the average results of different collaborators. Omitting one obviously low result, the over-all average for all collaborators is 98 per cent of the theoretical 1.00 per cent. This relative accuracy is approximately the same as that attained in the sulfaquinoxaline collaborative study last year.

ACKNOWLEDGMENTS

The Associate Referee feels deeply grateful to the following collaborators for their very considerable and efficient help: (1) Frederick A. Bacher, Research and Development Division, Merck & Co., Rahway, N. J.; (2) Roland W. Gilbert, Agricultural Experiment Station, Rhode Island State College, Kingston, R. I.; (3) L. D. Matterson, Poultry Department, the University of Connecticut, Storrs, Conn.; (4) Stanley W. Tyler, Wirthmore Research Laboratory, Malden, Mass.; (5) W. R. Flach, Eastern States Farmers' Exchange, Buffalo, N. Y.; (6) L. E. Bopst, State Inspection and Regulatory Service, College Park, Md.; (7) J. N. Turner, The Park & Pollard Co., Buffalo, N. Y.; and (8) William L. Hunter, Feed Laboratory, State Department of Agriculture, Sacramento, Calif.

RECOMMENDATIONS

It is recommended-

- (1) That the method be adopted as outlined (first action).
- (2) That studies be continued with the object of shortening the general method for sulfa drugs.
- (3) That collaborative studies of methods for nitrophenide and enheptin be undertaken.

• For report of Subcommittee A and action of the Association, see *This Journal*, 34, 41 (1951).

REPORT ON MINERAL CONSTITUENTS OF MINERAL FEEDS

SAMPLE PREPARATION FOR CALCIUM AND PHOSPHORUS IN
MINERAL FEEDS USING NITRIC-PERCHLORIC ACID

By J. L. ST. JOHN (Department of Agricultural Chemistry, Agricultural Experiment Stations and State Chemist's Laboratory, Pullman, Washington), *A880ciate Referee*

The work which has been in progress on mineral constituents in mixed feeds has resulted in the method 22.48--22.51, as published in the Seventh Edition of the *Book of Method8*. It is recommended* that this year these methods be made official.

The work completed was done on mineral constituents of *mixed feed8*. This year work has been continued on the use of the nitric-perchloric method of sample preparation for *mineral feed8*. Reports have been received from seven collaborators. It was requested that collaborators select two or three mineral feeds in common use in their own State, and

TABLE I.-Collaborative re8u8

	CALCIUM IN MINERAL FEEDS			PHOSPHORUS IN MINERAL FEEDS	
		LEVEL	DIFFERENCE	LEVEL	DIFFERENCE
Hunter	1.	<i>per cent</i> 37	<i>per cent</i> .10+	<i>per cent</i> 2.0	<i>per cent</i> .03-
Trinca	2.	23	.10+	8.0	.07-
	3.	4	.00	0.2	.05-
Fritz	1.	25	.54-	11.0	.15-
Takashima	2.	6	.06-	10.0	.02+
Geagley	1.	23	.08+	4.0	.06-
O'Meara	2.	27	.04-	5.0	.07-
Thorpe	3.	28	.12+	6.0	.20+
Randall	1.	13	.15-	1.5	.00
	2.	24	.01-	9.0	.30-
	3.	1	.21-	12.0	.43-
Baird	1.	3	.07	1.0	.11
Hammond	2.	17	.05	6.0	.01
	3.	33	.10	6.0	.08
Ingram	1.	32	.03-	15.0	.01+
	2.	21	.17-	4.0	.05-
	3.	28	.07+	6.0	.01-
Flach	1.	34	.14+		
	2.	20	.00		

* For report of Subcommittee A and action of the Association, see *This Journal*, 34, 41 (1951).

varying in the level of calcium and phosphorus, and varying somewhat in other constituents.

Based on results from the seven collaborators, Table 1 presents the difference between the results obtained by the present A.O.A.C. method, 27.47, where a sample is prepared by ashing, from the results obtained by nitric-perchloric acid digestion as above.

The differences between the results on both calcium and phosphorus are comparatively small in practically all cases. Further, these differences are sometimes positive and sometimes negative. Based on the results to date, it may be concluded that the two methods of sample preparation give essentially the same results.

REPORT ON TANKAGE (HIDE, HOOF, HORN, AND HAIR CONTENT)

By A. T. PERKINS (Kansas State College, Manhattan, Kansas),
Associate Referee

No further work has been done to find a satisfactory method for the separation of hide, hoof, horn, and hair content in meat scraps and tankages. It is recommended* that the method proposed by B. L. Smith and R. Colborn, as published in *This Journal*, 33, 474 (1950), be further studied.

No reports were given on lactose in mixed feeds; adulteration of condensed milk products, fluorine; protein evaluation in fish and animal products; or sampling and analysis of condensed buttermilk.

REPORT ON VEGETABLE DRUGS AND THEIR DERIVATIVES

By PAUL S. JORGENSEN (Food and Drug Administration, Federal
Security Agency, San Francisco 2, Calif.), *Referee*

RECOMMENDATIONS†

(1) *Theobromine and Phenobarbital*

A spectrophotometric method for the determination of theobromine and phenobarbital was developed. It includes the gravimetric method of separation of the two substances with the measurement of the quantity of each by means of spectrophotometer readings. A procedure is given for the chromatographic separation of salicylates. By this method the presence of iodides does not interfere with the determination of theobromine. Five collaborators obtained an average recovery for each in-

* For report of Subcommittee A and action of the Association, see *This Journal*, 34, 40 (1951).
† For report of Subcommittee B and action of the Association, see *This Journal*, 34, 45 (1951).

redient in excess of 99%. The Associate Referee recommends that the proposed spectrophotometric and gravimetric methods be adopted as first action. The Referee concurs.

(2) *Quinine and Strychnine*

No report was received. The Referee recommends that the subject be continued.

(3) *Rutin in Tablets*

A progress report was received from the Associate Referee. This report points out some of the probable interferences to the application of the usual technics employed in measuring rutin. The investigation is well under way and the Referee recommends that the subject be continued.

(4) *Aminopyrine, Ephedrine, and Phenobarbital*

No report was received. The Referee recommends that the subject be continued.

REPORT ON RUTIN IN TABLETS

By ARTHUR TURNER, JR. (Eastern Regional Research Laboratory, Philadelphia 18, Pennsylvania*), *Associate Referee*

In an effort to evaluate the complexity of the samples involved in this study, a letter was sent to each of approximately eighty rutin tablet manufacturers. This letter requested that they supply the Associate Referee with one thousand rutin tablets and a list of the ingredients. The letter also invited the manufacturers to participate in the collaborative study. To date there have been approximately forty replies. Nineteen manufacturers have submitted samples and thirteen have agreed to collaborate. This survey disclosed that, while the majority of the tablets are compounded of rutin and the usual excipients, there are many manufacturers marketing rutin in combination with other active ingredients. Some manufacturers prepare colored sugar-coated tablets containing rutin.

In view of probable interferences, as indicated by the survey, it was not feasible to submit the method of Porter *et al.*¹ for collaborative study. It is expected that the Associate Referee will investigate these interferences, submit a method to the collaborators, and have a report on the results of the study in time for the 1951 report.

* One of the laboratories of the Bureau of Agricultural and Industrial Chemistry, Agricultural Research Administration, U. S. Department of Agriculture.
¹ Porter, W. L., Brice, B. A., Copley, M. J. and Couch, J. F. • U. S. Department of Agriculture Publication, AIC-159, July 1947.

REPORT ON THEOBROMINE AND PHENOBARBITAL

By DANIEL BANES (Food and Drug Administration, Federal Security Agency, Washington, D. C.), *Associate Referee*

A gravimetric method for the determination of theobromine and phenobarbital was presented in a previous report on this subject.¹ Collaborative results indicated the reliability of the method for simple pharmaceutical preparations; but it proved inapplicable in the presence of potassium iodide or salicylates. This year's study was directed toward devising a spectrophotometric method which would permit the assay of complex preparations containing these interfering substances. A powdered sample was prepared to consist of theobromine (32.92%), phenobarbital (3.56%), salicylic acid (33.22%), cornstarch (27.16%), and smaller quantities of stearic acid, calcium carbonate, sucrose, lactose, and talc. It was requested that collaborators add 200-300 mg of reagent grade potassium iodide to each sample of the mixture assayed according to the instructions provided:

Details of the method are given in *This Journal*, 34, 80 (1951).

INSTRUCTIONS TO COLLABORATORS

- (1) Determine the theobromine and phenobarbital content of the sample in duplicate, using 0.7-1.0 g portions of the powder, and express as per cent.
- (2) Add to the first separatory funnel, before the alkali-chloroform extraction, about 200-300 mg of reagent grade potassium iodide.
- (3) The collaborative sample contains salicylates.

RESULTS OF ANALYSIS AND DISCUSSION

Results of analysis are presented in Table 1. Recoveries of both theobromine and phenobarbital are considered satisfactory, and the spectrophotometric assay augmented by the chromatographic partition technique appears to be applicable to the most complex mixtures in commercial use. The collaborators encountered no difficulty during the course of the analysis. Associate Referee Gordon Smith suggested that the final ammoniacal solutions of the phenobarbital standard and sample be filtered to ensure complete clarity for spectrophotometric measurements.

The present procedure employs the same separation technique as that in use for the gravimetric method, and spectrophotometry may be applied as a check analysis on the fractions obtained. The gravimetric recovery of theobromine may be improved by cooling the precipitating mixture to room temperature, and using as a wash solution HCl (1+9) saturated with crystalline theobromine phosphotungstate. Employing these modifications, the gravimetric procedure yields results commensurate with those obtained by the use of the spectrophotometric procedure. The latter is the more convenient.

¹ *This Journal*, 32, 533 (1949).

RECOMMENDATIONS.

It is recommended that the proposed spectrophotometric and gravimetric methods for theobromine and phenobarbital be adopted, first action, after modification in accordance with the suggestions mentioned, and that the subject be closed.

TABLE I.-Spectrophotometric recoveries of theobromine and phenobarbital

COLLABORATOR ¹	THEOBROMINE		PHENOBARBITAL	
	FOUND, GM/100 GM SAMPLE	RECOVERY	FOUND, GM/100 GM SAMPLE	RECOVERY
1	32.25	<i>per cent</i> 98.0	3.52	<i>per cent</i> 98.9
	32.17	97.7	3.50	98.3
2	32.22	97.9	3.46	97.2
	32.16	97.7	3.53	99.2
3	32.45	98.6	3.51	98.6
	32.59	99.0	3.55	99.5
4	34.2	103.9	3.50	98.3
	33.5	101.8	3.51	98.6
5	32.15	97.7	3.58	100.6
	32.15	97.7	3.69	103.7
	32.74	99.5		
Average	32.62	99.1	3.54	99.3
Maximum	34.2	103.9	3.69	103.7
Minimum	32.15	97.7	3.46	97.2

¹ The cooperation of the following collaborators, all of the Food and Drug Administration, is gratefully acknowledged: Robert D. Stanley, Chicago District; Rupert Hyatt, Cincinnati District; Gordon Smith, New York District; Matthew L. Dow, St. Louis District.

No reports were given on aminopyrine, ephedrine, and phenobarbital; or on quinine and strychnine.

REPORT ON SYNTHETIC DRUGS

By F. C. SINTON (Food and Drug Administration, Federal Security Agency, New York, N. Y.), *Referee*

RECOMMENDATIONS[†]

Carbromal.-The Associate Referee has submitted a report in which two methods for the determination of Carbromal were studied col-

* For report of Subcommittee B and action of the Association, see *This Journal*, 34, 45 (1951).

† For report of Subcommittee B and action of the Association, see *This Journal*, 34, 45 (1951).

laboratively on a mixture containing sodium pentobarbital in addition to carbromal. Method I showed somewhat more concordant results for carbromal than Method II; however, both methods appear satisfactory. Method II provided for determination of sodium pentobarbital in addition to the carbromal and the results on the collaborative sample were in close agreement.

The Associate Referee has recommended that the methods of assay for carbromal in mixtures be adopted as first action, and the topic closed. The Referee concurs, but recommends additionally Method II for both carbromal and barbiturates.

Methylene Blue.-No report. The Referee recommends that the subject be continued.

Diphenhydramine Hydrochloride (Benadryl®) and *Tripelennamine Hydrochloride* (Pyribenzamine®).-No report. The Referee recommends that the subject be continued.

Propylthiouracil.-A spectrophotometric method was tried out collaboratively. In view of the relatively wide variations in some of the results the Associate Referee has recommended that the subject be continued. The Referee concurs in this recommendation.

Propadrine Hydrochloride.-No report. The Referee recommends that the subject be continued.

Synthetic Estrogens.-The Associate Referee has submitted a report which includes a collaborative study of the determination of diethylstilbestrol in oil solution and in tablet mixture. He has recommended that the proposed method be adopted first action for diethylstilbestrol in oil, and that the subject be continued for the purpose of studying its adaptation for the assay of other preparations containing synthetic estrogens and their esters. The Referee concurs.

Spectrophotometric Methods.-Spectrophotometric methods were studied for the determination of methyl testosterone in tablets. The Associate Referee has recommended that the topic be continued and submitted to collaborative study. The Referee concurs.

Sulfanilamide Derivatives.-The Associate Referee has reported on investigational work to determine if a suitable internal indicator could be found for the titration of sulfonamides with standard sodium nitrite solution. The search for a suitable indicator was unsuccessful, and the Associate Referee recommends no further investigation of this problem.

Good results were obtained in the separation of sulfathiazole and sulfanilamide by absorption on alumina. The Associate Referee has recommended collaborative study on this problem, and that the separation of sulfamerazine, sulfadiazine, and sulfathiazole be studied. The Referee concurs in the recommendations of the Associate Referee.

Butacaine Sulfate.-The Referee recommends that the subject be continued.

REPORT ON SYNTHETIC ESTROGENS
DIETHYLSTILBESTROL

By D. BANES (Food and Drug Administration, Federal Security Agency,
Washington, D. C.), *A880ciate Referee*

Synthetic estrogens, employed as free phenols, or in the esterified form, have appeared commercially in tablets, in oil injections, and in creams. Gottlieb¹ studied various reactions for the determination of synthetic estrogens, and concluded that the nitrosation procedure of Lykken, Treseder, and Zahn² provided the best general method for this group of substances. In the present study, the reliability of the nitrosation procedure when employed in the assay of oil solutions and tablet mixtures containing diethylstilbestrol was tested collaboratively. Since prepara-

TABLE I.—*Recoveries of diethylstilbestrol*

COLLABORATOR	TABLET MIXTURE		OIL SOLUTION	
	FOUND	RECOVERY	FOUND	RECOVERY
1	<i>mg/gm</i>	<i>per cent</i>	<i>mg/ml</i>	<i>per cent</i>
	3.59	101.6	1.069	99.4
	3.62	102.5	1.056	98.1
2	3.50	99.1	1.070	99.4
	3.55	100.5	1.082	100.6
3	3.64	103.1	1.07	99.4
	3.72	105.4	1.07	99.4
4	3.48	98.6	1.067	99.2
	3.52	99.7	1.066	99.1
5	3.4	96.3	1.10	102.2
	4.0	113.3	1.08	100.4
6	3.58	101.4	1.063	98.8
	3.57	101.1	1.069	99.4
7	3.54	100.3	1.06	98.5
	3.66	103.7	1.06	98.5
Average	3.60	101.9	1.070	99.4
Maximum	4.0	113.3	1.10	102.2
Minimum	3.4	96.3	1.056	98.1

* The co-operation of the following collaborators is gratefully acknowledged:
Norman Stephenson, Food and Drug Divisions, Department of National Health and Welfare, Ottawa, Canada; and of Harold F. O'Keefe, Chicago District, Harry Shuman, Philadelphia District, A. Kramer, New York District, Halver C. Van Dame, Cincinnati District, and Jonas Carol, Division of Pharmaceutical Chemistry, of the U. S. Food and Drug Administration.

¹ GOTTLIEB, S., *J. Am. Pharm. Assn.*, 36, 379 (1947); *ibid.*, 37, 147 (1948).

² LYKKEN, L., TRESSEDER, R. S., and ZAHN, V., *Ind. Eng. Chem., Anal. Ed.*, 18, 103 (1946).

tions of synthetic estrogens for oral application often contain relatively large quantities of barbiturates, a powdered mixture was prepared to consist of diethylstilbestrol (0.353%), phenobarbital (17.34%), barbital sodium (27.26%), cornstarch (49.52%), and smaller quantities of stearic acid, calcium carbonate, sucrose, lactose, and talc. The oil solution contained 1.076 mg. of diethylstilbestrol per ml. of sesame oil. Collaborators were asked to analyze these samples in duplicate according to the instructions provided.

Details of the method are given in *This Journal*, 34, 79 (1951).

RESULTS OF ANALYSIS AND DISCUSSION

Results of analysis, shown in Table 1, indicate that the nitrosation procedure is reliable for the assay of oil solutions containing diethylstilbestrol. The presence of large quantities of barbiturates in tablet mixtures constitutes a slight interference in the direct method. Salicylates, which are also compounded with synthetic estrogen preparations, would also lead to high results. Both of these groups of acidic substances must be removed before color development. The method would also require a hydrolysis technique to render it applicable to esterified synthetic estrogens.

RECOMMENDATIONS.

It is recommended that the proposed method be adopted, first action, for diethylstilbestrol in oil, and that the subject be continued for the purpose of studying its adaptation for the assay of other preparations containing synthetic estrogens and their esters.

REPORT ON CARBROMAL IN MIXTURES

By RUPERT HYATT (U. S. Food and Drug Administration, Federal Security Agency, Cincinnati, Ohio), *Associate Referee*

Work done on this subject last year involved the application of two official methods to its examination. These two methods, 34.90 and 32.137 (modified), were found to give sufficiently precise results in the hands of several collaborators. However, any other organic ingredients that were present would be destroyed, and carbromal alone would be calculated from the amount of bromine found.

Carbromal is often dispensed in combination with other sedatives, particularly the barbiturates. Since an examination of such a mixture would require the determination of barbiturates also, an extraction method was studied so that both ingredients could be reported. The work done this year involved sending two methods to collaborators,

• For report of Subcommittee Band action of the Association, see *This Journal*, 34, 45 (1951).

the first being **34.90** and the second being an extraction method. The details of the methods are given in *This Journal*, **34**, 78 (1951).

A sample was prepared in the laboratory using N.F. carbromal, C.P. sodium pentobarbital, and starch. The mixture contained 49.0% of carbromal and 19.5% of sodium pentobarbital. The mixture was sent to collaborators along with the following instructions and procedures:

INSTRUCTIONS TO COLLABORATORS

Please examine sample in duplicate by both methods. If smaller bulbs than those described in **34.90** are used, care must be observed to prevent absorbing solution from spurting out the open end. Include any comments you desire to make.

The results of the examination of the collaborative sample are shown in the table below.

COLLABORATOR	CARBROMAL, METHOD 1	CARBROMAL, METHOD 2	Na PENTOBARBITAL	AVERAGE RECOVERY, METHOD 1	AVERAGE RECOVERY, METHOD 2
	<i>per cent</i>	<i>per cent</i>	<i>per cent</i>	<i>per cent</i>	<i>per cent</i>
1	49.3-48.9	49.0 -47.9	19.6 -20.3	100.2	98.9
2	49.1-49.1	46.2 -47.1	20.3 -20.5	100.2	95.2
3		48.90-48.45	18.96-18.72		99.3
4	48.0-48.3	47.67-48.30	18.85-18.70	98.3	97.9
5	48.4-48.3	47.4 -47.8	20.1 -20.0	98.7	97.1
6	48.1-47.9	46.9 -47.2	20.4 -20.2	98.0	96.0
Average	48.5	47.7	19.7		
Average Recovery %	99.0	97.4	101.0	99.1	97.4

The proper melting points were obtained in all cases.

COMMENTS OF COLLABORATORS

R. L. Herd. - "I prefer the A.O.A.C. method 34.90 for carbromal due to the probability of loss of carbromal due to the heating of the CHCl_3 extract."

Charles Graichen and Keith S. Heine. - "We have analyzed the collaborative samples with the above results. We found the method to be clean-cut and simple."

COLLABORATORS

Grateful appreciation is expressed for work done by Charles Graichen, Keith S. Heine, R. L. Herd, Harold F. O'Keefe, and Harry Rogavitz of the U. S. Food and Drug Administration.

DISCUSSION OF RESULTS

The results on the collaborative sample were generally satisfactory.

The method appears to give good results on the types of carbromal preparations encountered on the market.

It is recommended* that the methods of assay for carbromal in mixtures be adopted as first action, and the topic closed.

REPORT ON SPECTROPHOTOMETRIC METHODS

THE DETERMINATION OF METHYLTESTOSTERONE IN TABLETS BY ABSORPTION SPECTROPHOTOMETRY

By JONAS CAROL (Food and Drug Administration, Federal Security Agency, Washington, D. C.), *Associate Referee*

Methyltestosterone is used extensively as an androgenic agent because of its effectiveness when administered orally. It is official in the U.S.P. XIV in crystalline form and as tablets. The assay method for tablets, based on optical rotation, is nonspecific: many organic compounds, extractable by benzene, possess optical activity. The method is also undesirable because of the large sample (100 mg. methyltestosterone) and the six-hour extraction period required.

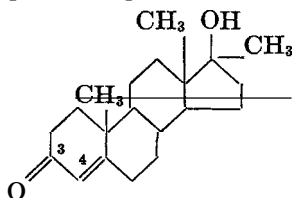

Methods of analysis based on absorption spectrophotometry are widely used for the determination of other steroid hormones (1, 2, 3, 4) and should be suitable for the estimation of methyltestosterone in tablets. Compounds having an α, β unsaturated ketone group, as found in methyltestosterone at carbons 3 and 4 in ring A, exhibit strong ultraviolet absorption (5). A procedure for methyltestosterone, using optical density measurements made at the absorption band due to this configuration, would not be entirely specific, but would be much more selective than one depending on optical rotation. The adrenal cortex hormones, progesterone, and testosterone are the only steroid hormones commonly encountered that have this type of unsaturation.

The optical density of an alcoholic solution containing 2.50 mg methyltestosterone (m.p., 164° [α]_D²⁰ +75°) per 100 ml was determined relative to alcohol from 210-300 m μ using a Carey Recording ultraviolet spectrophotometer equipped with 1 cm matched quartz cells. The absorption curve had a single sharp maximum at 241 m μ ($E_{1\%}^{1\text{cm}} = 576$). A series of solutions containing 0.20-1.00 mg methyltestosterone per 100 ml of

* For report of Subcommittee B and action of the Association, see *This Journal*, 34,45 (1951).

alcohol were prepared, and their optical densities relative to alcohol were determined at $241\text{ m}\mu$. The data obtained, tabulated in Table 1, show that a straight line relationship exists between concentration and optical density.

TABLE I.-Variation of optical density with concentration of solutions of methyltestosterone at $241\text{ m}\mu$

MG PER ML 100 ALCOHOL	$E_{1\text{cm}} 241\text{ m}\mu$
0.20	.114
0.40	.226
0.60	.340
0.80	.449
1.00	.568

Analytical procedures using infrared absorption spectrophotometry are in general highly specific, as no two compounds, with the exception of enantiomorphs, have identical infrared absorption spectra. Infrared spectra are usually composed of many maxima and it is almost always possible to make absorption measurements at wave lengths where commonly occurring contaminants have little or no absorption. A limiting factor in infrared spectrophotometry is scarcity of relatively transparent solvents. Methyltestosterone is easily soluble in carbon disulfide, the best general solvent for infrared spectrophotometry. The infrared absorption spectrum of a solution containing 10 mg methyltestosterone per ml. of carbon disulfide was traced from $5\text{--}14\mu$ using a Perkin-Elmer Model B Recording Spectrophotometer equipped with sodium chloride windows and prism and 1.0 mm cells (3). The spectrum reproduced in Figure 1 shows a strong band at 6μ due to the carbonyl group at C_3

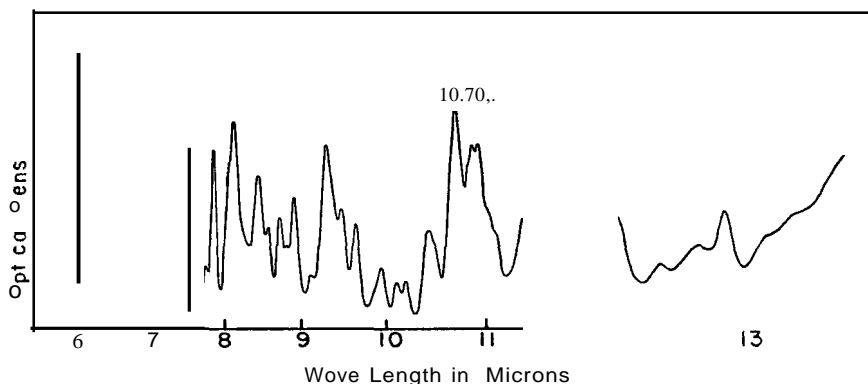

FIG. I.-The infrared absorption spectrum of methyltestosterone 10 mg/ml OS. 1.0 mm cell.

conjugated to the double bond at C₄. A number of well defined bands are present in the "finger-print" region from 8-14 μ . The strong band at 10.70 μ was selected as a suitable wavelength for quantitative measurements. A series of solutions containing 2.5-12.5 mg methyltestosterone per ml of carbon disulfide was prepared and their optical densities, relative to a carbon disulfide blank, were determined at 10.70 μ using 1.0 mm cells. The data, recorded in Table 2, show that a straight line relationship exists between concentration and optical density.

TABLE 2.-Variation of optical density with concentration of solutions for methyltestosterone at 10.70 $m\mu$

MG PER ML CS ₂	El. $m\mu$
2.5	0.095
5.0	0.189
7.5	0.286
10.0	0.370
12.5	0.465

Based on the above spectrophotometric data, two methods are presented for the determination of methyltestosterone in tablets. The infrared procedure, because of its specificity, is preferred and should be used if the apparatus is available. The ultraviolet method is much more sensitive and can be employed to determine very small amounts.

METHOD I.-ULTRAVIOLET

APPARATUS

A spectrophotometer suitable for measuring absorption at 241 $m\mu$.
Two matched 1 cm. quartz absorption cells.

REAGENTS

Ether.-U.S.P. grade.
Sodium Bicarbonate Soln.-A saturated aqueous soln.
Methyltestosterone.-U.S.P. Reference Standard.
Alcohol.-95%.

STANDARD SOLUTION

Dissolve 50 mg methyltestosterone, accurately weighed, in alcohol; transfer to a 100 ml volumetric flask, and dilute to mark with alcohol. Mix and pipette a 10 ml aliquot into a 500 ml volumetric flask. Make to mark with alcohol.

DETERMINATION

Weigh a portion of the powdered tablet material containing the equivalent of 5-10 mg of methyltestosterone and transfer to a 125 ml separator containing 25 ml of water. Add 25 ml of ether and shake carefully for 1 min. Allow the layers to separate and transfer the aqueous fraction to a second 125 ml separator. Extract as before and transfer the aqueous layer to a third 125 ml separator, add another 25 ml of ether and extract again. Discard the aqueous layer. Wash the ether fractions in succession with 5 ml of saturated sodium bicarbonate soln of two 5 ml

portions of water. Discard the aqueous washes and transfer the ether solns to a 150 ml beaker. Evaporate to dryness on a steam bath with the aid of a current of air. Dissolve the residue in alcohol, transfer quantitatively to a 100 ml volumetric flask and make to the mark with alcohol. Pipette a 10 ml aliquot to a second 100 ml volumetric flask, and make to the mark with alcohol. Determine the optical density of the sample and standard solns, relative to alcohol, at 241 μ .

$$\text{mg. methyltestosterone per av. tablet} = \frac{E_{\text{sample}} \times \text{av. wt. per tablet}}{E_{\text{standard}} \times \text{wt. sample}}$$

METHOD 2.—INFRARED

APPARATUS

An infrared spectrophotometer equipped with a sodium chloride prism and two 1.0 mm liquid absorption cells.

REAGENT

Carbon Disulfide.—A.C.S. reagent grade.

STANDARD SOLUTION

Transfer 50 mg methyltestosterone, accurately weighed, to a 5 ml volumetric flask, and make to volume with carbon disulfide. As the solvent is highly volatile this standard should be prepared just before use.

DETERMINATION

Extract the ground tablet material as directed under the ultraviolet procedure. Dissolve the methyltestosterone residue in a small amount of chloroform and transfer quantitatively to a 15×50 mm glass-stoppered weighing bottle. Carefully evaporate the soln to dryness on a steam bath using a current of air. Using a 1-ml pipette, or a graduated hypodermic syringe, add 1 cm of carbon disulfide, stopper the bottle immediately, and dissolve the residue by gentle mixing. Determine the optical densities of the sample and standard soln, relative to a blank of carbon disulfide, at 10.70 μ .

$$\text{mg. methyltestosterone per av. tablet} = \frac{E_{\text{sample}} \times 10 \times \text{av. wt. per tablet}}{E_{\text{standard}} \times \text{wt. sample}}$$

A series of mixtures were prepared to simulate the composition of commercial methyltestosterone tablets and each sample was analyzed by the above two methods. Results of analysis are shown in Table 3.

TABLE 3.—Analysis of methyltestosterone in tablet mixtures

ADDED	RECOVERED BY	
	U.V.	I.R.
per cent	per cent	per cent
10.5	10.5	11.0
25.0	24.2	25.7
48.8	49.4	48.6
56.3	56.9	55.7

A number of commercial tablets were also determined by the above two methods with satisfactory results.

CONCLUSIONS AND RECOMMENDATIONS*

Two spectrophotometric methods are proposed for the determination of methyltestosterone in tablets. Both are more specific than the present official USP method.

Good results have been obtained by both procedures on synthetic mixtures and commercial samples.

It is recommended that the topic be continued and submitted to collaborative study.

REFERENCES

- (1) ELVIDGE, W. F., *Quart. J. Pharm. Pharmacol.*, 12, 347 (1939).
- (2) VENNING, E. H., EVELYN, K. A., HARKNESS, E. V., and BROWNE, J. S. L., *J. Biol. Chem.*, 120, 225 (1937).
- (3) CAROL, J., MOLITOR, J. C., and HAENNI, E. O., *J. Am. Pharm. Assoc., Sc. Ed.*, 37, 173 (1948).
- (4) BANES, D., *Ibid.*, 39, 37 (1950).
- (5) FIESER, L. F., and FIESER, M., "Natural products related to phenanthrene," New York, 3rd edition, 190 (1949).

REPORT ON PROPYLTHIOURACIL

By GORDON SMITH (Food and Drug Administration, Federal Security Agency, New York), *Associate Referee*

A spectrophotometric method has been tried out collaboratively. A quantity of propylthiouracil powder was first obtained through the courtesy of the manufacturer. This was further purified by crystallization from alcohol, grinding, and drying. Part of the resultant powder was used as a standard, and part was used to make a tablet mixture. The latter was made of 50.00% propylthiouracil, the other ingredients being starch, talc, lactose, and magnesium stearate.

Plotting the light absorption of an ammoniacal solution of propylthiouracil against wave length, over the ultraviolet range, showed a maximum in the vicinity of 233 $m\mu$. A plot of absorption versus concentration, at this wave length, showed a linear relationship. Details of the method, which makes use of the foregoing facts, are given below. The Beckmann instrument was used.

The results obtained by five collaborators, including the Associate Referee, in assaying the tablet mixture, were as follows: 46.09 per cent; 49.3 per cent; 52.60 per cent; 48.15 per cent; and 49.5 per cent.

These indicate that the method needs further study to eliminate the cause of the variation. It is recommended† that the subject be continued.

METHOD

Weigh out and transfer to a 200 ml volumetric flask a quantity of sample con-

* For report of Subcommittee B and action of the Association, see *This Journal*, 34, 45 (1951).

† For report of Subcommittee B and action of the Association, see *This Journal*, 34, 45 (1951).

taining 50 mg of propylthiouracil. To another 200 ml volumetric flask transfer exactly 50 mg of pure propylthiouracil standard. To each add 150 ml of ca 2% NH.OH. Shake sample flask continuously for 1 min. Shake standard flask until propylthiouracil is completely dissolved. Fill both flasks to mark with ca 2% NH.OH and mix completely. Filter sample soln, rejecting first 30 ml of filtrate.

Using three 500 ml volumetric flasks, pipet into one of them 10 ml of sample filtrate, into second 10 ml of standard soln, and into third 10 ml of ca 2% NH.OH. (The same batch of 2% NH.OH must be used thruout.) Fill all 3 flasks to mark with H₂O and mix completely. The soln in third flask is for use as a blank.

Determine the optical density of the dilute sample soln and of the dilute standard soln, relative to the blank, at 233 m μ , applying cell corrections if necessary. Calculate propylthiouracil content of sample. (Report per cent.)

ACKNOWLEDGMENT

Thanks are expressed to the following members of the Food and Drug Administration, who collaborated: L. G. Ensminger, Cincinnati; A. Kramer, New York; J. C. Molitor, Washington; and H. F. O'Keefe, Chicago.

REPORT ON BUTACAINE SULFATE

By LLEWELLYN H. WELSH (Food and Drug Administration, Federal Security Agency, Washington, D. C.), *Associate Referee*

Collaborative study conducted in 1949 was related to the analysis of various dosage forms of butacaine sulfate including ointments containing 2 per cent or more of the drug.¹ It seemed probable that the method found suitable for such ointments would be applicable also to 1 per cent ointments, but the possibility remained that the necessarily larger sample required by the latter product might lead to mechanical difficulties (emulsion formation, etc.). For this reason it was recommended that the subject be continued with respect to ointments containing less than 2 per cent of the drug. The present report concerns the analysis of 1 per cent ointments.

The ointment sent to collaborators contained 1.00% butacaine sulfate in a base consisting of lanolin, 1 part, and petroleum jelly, 19 parts. Instructions accompanying the collaborative samples were identical with those sent to collaborators in the 1949 study. Of the three prospective collaborators, only one reported. His results and those of the Associate Referee are shown in Table 1.

Although the ointment was analyzed in only two laboratories, it is believed that the analytical data are sufficient to justify the conclusion that the method is suitable for 1 per cent ointments. This belief is based on the considerations (1) the method has been adopted, first action, for 2 per cent ointments, and (2) the larger sample size required in the assay

¹ Welsh, L. H., *Thi. Journal*, 33, 206 (1950).

TABLE 1.—*Results of collaborator*⁸

COLLABORATOR	BUTACAINE SULFATE	
	FOUND	RECOVERED
Rupert Hyatt, U. S. Food and Drug Administration, Cincinnati, Ohio	<i>per cent</i>	<i>per cent</i>
	1.00	100
L. H. Welsh, U. S. Food and Drug Administration, Washington, D. C.	1.01	101
	1.01	101

of the 1 per cent product presented no mechanical difficulties in the hands of the two collaborators.

RECOMMENDATIONS*

It is recommended that the first action status of the analytical method for butacaine sulfate ointments be extended to include those containing 1 per cent of the drug. It is also recommended that the subject be closed.

REPORT ON SULFANILAMIDE DERIVATIVES

By H. W. CONROY (U. S. Food and Drug Administration, Federal Security Agency, Kansas City, Mo.), *Associate Referee*

This subject has been assigned for the past seven years and no report has been made by the Associate Referees to whom the topic was given. This report deals with investigational work done to determine if a suitable internal indicator could be found for the titration of sulfonamides with standard sodium nitrite solution; it also deals with a study of methods which might be used for the separation of mixtures of sulfonamides.

In the experimental work done on internal indicators, such reagents as have been reported in the literature to have properties which make them suitable for this purpose, were used. In addition, a number of indicators and dyes were tested to determine their usefulness for the purpose.

Acridine in dilute solution has been reported¹ to be suitable as an internal indicator, to indicate the approach of the end point and with practice, the end point itself. Just before the end point, the color is somewhat purple instead of yellow, but it is violet at the true end point. The color change from yellow to violet is irreversible and if the indicator is added too soon, more must be added later.

Azo dyes with biphenyl radical have been reported¹ as indicators for nitrous acid. The procedure directs the addition of an excess of nitrite

* For report of Subcommittee B and Action of the Association, see *This Journal*, 34, 45 (1951).

¹ *The Analyst*, 68, 51 (1943).

² *C. A.* Vol. 28, 3684 (1934).

solution and the titration of the excess with a standard sulfanilic acid solution. Metanil Yellow, the dye used, is pink in the titrating medium, goes to colorless at or near the end point, and becomes pink upon titration of the excess nitrous acid with the standard sulfanilic acid. The indicator change was found more sensitive when the acidity of the titrating medium was low; however, the titration of the sulfonamides is carried out in varying concentrations of hydrochloric acid and the indicator sensitivity is decreased at stronger concentrations.

Quantitative results obtained by use of these indicators were less than theoretical and not as satisfactory as outside starch indicator. Acriflavine changes before the end point and the addition of more indicator did not produce a sharp, readily recognizable end point. Metanil Yellow, at the acid concentrations used in the titration of sulfonamides, has a slow transition from pink to colorless. The addition of an excess of standard nitrite solution with subsequent back titration with standard sulfanilic acid introduces the possibility of loss of nitrous acid.

Approximately fifty indicators and dyes were tested to determine their suitability as internal indicators and none was found useful for the purpose. The Associate Referee recommends that no further investigation be made of this problem.

No methods were found in the literature for actual separation of mixtures of sulfonamides; however, the work of W. A. Schroeder and associates³ reports the separation and quantitative determination of a number of organic compounds by adsorption on silicic acid, and it was considered that the technique might be applicable to the separation of sulfonamides. For experimental purposes a mixture of equal parts of sulfanilamide and sulfathiazole was prepared. The amount of the mixture used (0.2 gm) in a determination was larger than would be used where subsequent estimation of the constituents is made by spectrophotometric methods. The amount of silicic acid (30 gm) and size of chromatographic tube (4.5"X1") are also larger than usual. The silicic acid on the column was prewashed with 2 volumes of ether and the mixture of sulfanilamide and sulfathiazole in 140 ml of 1+6 acetone ether solvent put through the column. The sulfanilamide was completely eluted by washing with additional 240 ml of the acetone ether solvent mixture, and the sulfathiazole, which is more strongly adsorbed, was removed by 3-30 ml portions of acetone.

Separation of the above prepared mixture was also accomplished by adsorption on alumina (80-200 mesh) prepared for chromatographic adsorption. Ten grams of alumina in a 16 mmX240 mm tube was prewashed with 2 volumes of acetone, 0.2 gm of the mixture in 20 ml of acetone was put through the column, and washing with acetone was continued until a test for complete extraction of sulfanilamide showed a negligible residue (ca 80 ml). The acetone extract was evaporated in a tared con-

tainer and when the residue was nearly dry, several 5-10 ml portions of alcohol were added to the residue and evaporated, to aid in the removal of diacetone alcohol apparently formed by the passage of acetone thru the alumina. The residue was then dried at 100°. to constant weight. The sulfathiazole remaining on the column was then eluted with a mixture of 5 ml ammonium hydroxide and 95 ml alcohol and a test for complete extraction was made. After evaporation of the solvent, the sulfathiazole was dried at 100°. for short intervals to constant weight.

RESULTS

The adsorption on alumina was more satisfactory than on silicic acid, in reproducibility of results and ease of manipulation. The following recoveries were obtained, using for each determination 0.2 gm of the mixture prepared from equal weights of sulfanilamide and sulfathiazole.

ABSORBENT	ALUMINA		SILICIC ACID		MELTING POINT
	GM	RECOVERY	GM	RECOVERY	
Sulfanilamide	.1000	<i>per cent</i> 100.0	.1025	<i>per cent</i> 102.5	165-6°C.
	.1030	103.0	-	-	
Sulfathiazole	.1005	100.5	.1030	103.0	• 200-204°C.
	.0975	97.5	.1004	100.4	

* Recrystallized from water.

RECOMMENDATIONS.

It is recommended that collaborative study be made of the separation of sulfathiazole and sulfanilamide by adsorption on alumina and that the separation of sulfamerazine, sulfadiazine, and sulfathiazole be studied, since this combination is common.

No reports were given on methylene blue; propadrine hydrochloride; or diphenhydramine hydrochloride (Benadryl®) and tripeleminamine hydrochloride (Pyribenzamine®)

* For report of Subcommittee Band action of the Association, see *This Journal*, 34, 45 (1951).

REPORT ON MISCELLANEOUS DRUGS

By I. SCHURMAN (Food and Drug Administration, Federal Security Agency, Chicago 7, Illinois), *Referee*

RECOMMENDATIONS.

Estrone and Estradiol.-The Associate Referee has submitted a very comprehensive and thorough report. The collaborative results are in very good agreement with theoretical. The Associate Referee recommends (1) that the method for the determination of ketosteroids (gravimetric) be adopted, first action; (2) that the method for the determination of ketosteroids (colorimetric) be adopted, first action; (3) that the method for the determination of alpha-estradiol be adopted, first action. The Referee concurs and recommends that the topic be closed.

Microscopic Tests for Alkaloids and Synthetics.-No report received. Referee recommends that subject be continued.

Mercury Compounds.-No report. Referee recommends that subject be continued.

Organic Iodides.-No report. Referee recommends that subject be continued.

Alkali Metals.-Associate Referee states that work is in progress but that a written report cannot be submitted at this time. The Referee recommends that the subject be continued.

Glycols and Related Compounds.-Referee recommends that the subject be continued.

Preservatives and Bacteriostatic Agents in Ampul Solutions.-Referee recommends that the subject be continued.

Methyl Alcohol.-Report to be made by Referee on Alcoholic Beverages.

REPORT ON ESTRONE AND ESTRADIOL

By EDWARD O. HAENNI (Food and Drug Administration, Federal Security Agency, Washington, D. C.), *Associate Referee*

There has been no prior A.O.A.C. report on chemical methods for the determination of the steroid estrogens. This complex problem has been studied for several years in the Division of Pharmaceutical Chemistry of the Food and Drug Administration. The methods developed from this work for the assay of estrone in oil solutions, estradiol in tablets, and estradiol benzoate in oil solutions have been incorporated in U. S. P. XIV. In addition to such preparations of pure estrogens the regulatory chemist finds products described as mixed estrogens from equine pregnancy urine presenting much more complex analytical problems. Because background material and the methods studied have already been published or sub-

* For the report of Subcommittee B and action of the Association, see *This Journal*, 34, 46 (1951).

TABLE I.-Collaborative results (concentrations in mg/ml)

SAMPLE	TESTONE		EQUILIN		EQUILININ		EPIOSTERONS (GRAVIMETRIC)		ALPHA- ESTRADIOL		BETA- ESTRADIOL	
	I	n	I	II	I	II	I	II	I	II	I	II
Analyst A	0.75	0.47	0.25	0.09	0.24	0.04	1.26	0.62	0.023	0.030	0.060	0.006
B	0.84	0.50	0.35	0.10	0.20	0.05	1.34	0.68	0.023	0.024	0.067	0.009
C	0.78	0.48	0.23	0.08	0.26	0.05	1.40	0.67	0.0225	0.0285	0.059	0.0065
	0.78	0.47	0.22	0.08	0.28	0.06	1.44	0.67	0.0225	0.027	0.0595	0.006
D	0.79	0.47	0.29	0.10	0.23	0.05	1.38	0.65	0.021	0.031	0.060	0.006
E	0.80	0.47	0.26	0.09	0.20	0.04	1.42	0.70	0.018	0.030	0.059	0.006
Average	0.79	0.48	0.27	0.09	0.235	0.05	1.37	0.665	0.022	0.028	0.061	0.007
Present ¹	0.79	0.50	0.31	0.10	0.25	0.05	1.35	0.65	0.020	0.030	0.061	0.006

¹ Sample I contained in addition: alpha-dihydroequilin 0.030 mg/ml, alpha-dihydroequilenin 0.050 mg/ml, and beta-dihydroequilenin 0.050 mg/ml.

mitted for publication (1-9) detailed discussion is not necessary here. Sophistication in the case of such products usually involves increasing the content of the highly potent alpha-estradiol (present in insignificant proportions in equine pregnancy urine) either by addition as such or by chemical reduction of the estrone present. Such reduction would potentially yield alpha- and beta-estradiols (from estrone), alpha- and beta-dihydroequilenins (from equilenin), and alpha- and beta-dihydroequilins (from equilin). The instability of beta-dihydroequilin to acid makes its presence in such mixtures most improbable. The potency of the dihydro compounds other than alpha-estradiol is quite low compared to that of the latter in the bio-assay. Accordingly, the potent ketosteroids estrone and equilin, together with the alpha-estradiol, constitute the important indices of sophistication.

Two samples of mixed estrogens in sesame oil were prepared for collaborative study. The equilin was added by the collaborators at the time of analysis to avoid deterioration of the equilin in the oil (9). The instructions to the collaborators follow:

NOTES TO COLLABORATORS

Two samples (I and II) of estrogens in oil, together with a solution of equilin, are submitted.

For the assay of Sample I transfer 5.0 ml of the oil to a 125 ml separatory funnel as described in the method under "Oil Solutions." Carefully evaporate 2.50 ml of the equilin solution just to dryness in a small beaker. Dissolve the residue in a few ml of CHCl_3 and transfer to the solution in the funnel with a small volume of CHCl_3 and Skellysolve C, limiting the total volume of CHCl_3 used to about 5 ml. Proceed with the alkali extraction described in method.

For the assay of Sample II use 10.0 ml of the oil and add the residue from 2.00 ml of the equilin solution as described for Sample 1.

Those collaborators who are accustomed to following the procedures issued on November 22, 1949, are requested to note the changes in the directions provided for the collaborative work, particularly in the ketosteroid colorimetric methods and in the partition of the diols.

Please complete the assays as promptly as possible (3 days are usually required) and report the following results: ketosteroids (gravimetric), estrone, equilin, and equilenin, in terms of milligrams per ml of sample, and alpha- and beta-estradiols in terms of micrograms per ml of sample.

Details of the methods are given in *This Journal*, **34**, 82-89 (1951).

DISCUSSION

The composition of the samples and the collaborative results are shown in Table 1. One collaborator did not submit a report.

In considering the results it must be borne in mind that we have to deal with the determination of micro quantities of very closely related compounds admixed with relatively huge proportions of extraneous material. The results for estrone, the most important component of the ketosteroids, are quite good. The equilin and equilenin determinations yielded some-

what greater variation in results, but are nevertheless entirely adequate. In the case of Sample I it was discovered that some of the estrone used in the preparation contained an appreciable quantity of equilin. It is to be expected that some of this equilin decomposed in the oil before analysis of the sample. The one high result for equilin in this sample is associated with a low result for equilenin, suggesting that incomplete esterification occurred in the equilin determination. The results for total ketosteroids determined gravimetrically agree closely with the ketosteroid content and show a narrow range of variation with both samples. This is significant, because the method includes a screening test for the presence of equilin and equilenin which obviates the necessity for further colorimetric analysis of the ketosteroid residue in their absence. The residue is then assumed to be entirely estrone.

The determination of alpha-estradiol is particularly difficult because it is normally present only in microgram quantities and there is no specific test for it in such quantities. Sample I provided a severe test of the method in that it contained alpha-dihydroequilin and three times as much beta-estradiol as alpha-estradiol. Both of these react in the color test for alpha-estradiol and the latter must be determined by difference. The results are in good agreement but tend to be slightly high in this sample. In the case of Sample II all but one of the results check well with the alpha-estradiol content. This result is associated with an unusually high beta-estradiol result, which would be expected to yield a low value for alpha-estradiol.

Although the method provides for the determination of alpha-dihydroequilin when present in the eluate fraction containing the estradiols, the collaborators were not requested to report their results for alpha-dihydroequilin because the partition chromatographic procedure used was not designed to completely recover that substance under all conditions.

The Associate Referee considers that the results of the collaborative study justify his recommendation that the methods be adopted, first action.

ACKNOWLEDGMENT

The Associate Referee appreciates the great amount of work required of the collaborators in this study and thanks the following (all of the Food and Drug Administration) for their reports: Harry Isacoff, New York, N. Y.; Harold O'Keefe, Chicago, Illinois; Halver Van Dame, Cincinnati, Ohio; Arthur W. Steers, Los Angeles, California.

RECOMMENDATIONS.

It is recommended-

- (1) That the method for the determination of ketosteroids (gravimetric) be adopted, first action.
- (2) That the method for the determination of ketosteroids (colorimetric) be adopted, first action.

* For report of Subcommittee B and action of the Association, see *This Journal*, 34, 46 (1951).

(3) That the method for the determination of alpha-estradiol be adopted, first action.

REFERENCES

- (1) CAROL, J., and ROTONDARO, F. A., *J. Am. Pharm. A88oc.*, **35**, 176 (1946).
- (2) CAROL, J., and MOLITOR, J. C., *Ibid.*, 36, 208 (1947).
- (3) CAROL, J., MOLITOR, J. C., and HAENNI, E. O., *Ibid.*, 37,173 (1948).
- (4) BANES, D., *Ibid.*, 39, 37 (1950).
- (5) CAROL, J., HAENNI, E. O., and BANES, D., *J. Biol. Chem.*, 185, 267 (1950).
- (6) CAROL, J., *J. Am. Pharm. A88oc.*, 39, 425 (1950).
- (7) BANES, D., CAROL, J., and HAENNI, E. O., *J. Biol. Chem.*, 187, 557 (1950).
- (8) HAENNI, E. O., *J. Am. Pharm. A88oc.*, 39, 544 (1950).
- (9) BANES, D., CAROL, J., and HAENNI, E. O., *Ibid.*, 39, 541 (1950).

REPORT ON PRESERVATIVES AND BACTERIOSTATIC AGENTS IN AMPUL SOLUTIONS

By CHARLES N. JONES (Food and Drug Administration, Federal Security Agency, New York, N. Y.), *Associate Referee*

Investigations continued during the past year on the determination of cresol, and were expanded to include the esters of para hydroxy benzoic acid. As shown in the previous report¹ the three isomers of cresol reacted differently towards the same reagents, which eliminated the use of these single reactions as a means of the accurate determination of total cresol. In order to anticipate the effect of a variable concentration on anyone reaction, the following information was obtained from a local producer of cresol as an average cresol. This composition was not verified, and is in itself subject to wide variations between lots.

	<i>Per cent</i>
Meta cresol	49
Para cresol	26
Ortho cresol	13
Phenol	4
Xylenols, and higher phenols	8

On the basis of such a composition as above, any method that determines only the three isomers of cresol would inherently introduce an error of 12 per cent of the total cresol added. It is felt that this would be beyond the limits of accuracy desired for a method.

It is now proposed to re-evaluate all of the methods available for cresol to select that method which would give the least possible error for the major components, thereby holding the over-all error to a minimum value.

A colorimetric method for para hydroxy benzoic acid and its esters was studied. This method gave good recoveries on controls, but further work is necessary before submitting it for collaborative study.

The Associate Referee recommends* that the work be continued.

¹ *This Journal*, **33**, 219 (1950).

* For report of Subcommittee B and action of the Association, see *This Journal*, 34, 46 (1951).

REPORT ON GLYCOLS AND RELATED PRODUCTS

By HARRY ISACOFF (Food and Drug Administration, Federal Security Agency, New York, N. Y.), *Associate Referee*

The method¹ submitted by the Associate Referee, last year, for the separation of glycols from drug mixtures by a codistillation procedure, has been applied to a mixture containing propylene glycol.

It was noted that a contributed paper² on the determination of propylene glycol in vanilla extracts used essentially the same method with heptane as an entraining solvent. To study the application of the method to drug products an Elixir of Terpin Hydrate, N. F., was prepared and a known amount of propylene glycol substituted for the glycerin normally present. Cyclohexane was used as the entraining solvent, and the recovered propylene glycol was determined in the aqueous distillate by the periodate method.³

A preliminary separation of volatile constituents such as essential oils had been considered and was incorporated in the procedure. The amount of sample taken for analysis in a preparation of the type studied is small, the volatile oils would be present in very small amounts and these would be held in the cyclohexane layer. The preliminary separation procedure was therefore discarded.

Satisfactory recoveries of the propylene glycol were obtained in the codistillation method. It is recommended* that the method be submitted for collaborative study.

No reports were given for microscopic tests for alkaloids and synthetics; mercury compounds; organic iodides and separation of halogens; alkali metals; or methyl alcohol.

REPORT ON SOILS AND LIMING MATERIALS

By W. H. MACINTIRE (The University of Tennessee Agricultural Experiment Station, Knoxville, Tenn.), *Referee*

The extent of the work accomplished by the Associate Referees is recorded in the accompanying reports submitted by them. The Referee has acted also as *ad interim* Associate Referee on the determination of the fluorine content of soils. The work done in his laboratory and in the Bureau of Plant Industry, Soils, and Liming Materials, USDA, is presented in a separate report, *This Journal*, page 597.

¹ *This Journal*, 33, 218 (1949).

² *Ibid.*, 33, 103 (1949).

³ *Ibid.*, 26, 249 (1943).

* For report of Subcommittee B and action of the Association, see *Thi. Journal*, 34, 46 (1951).

Because of the findings embodied therein, and because of the citations as to preceding Referee findings, recommendation No.6 is made.

Concurrence in Associate Referee recommendations and suggestions for incompletd assignments follow.

RECOMMENDATIONS*

It is recommended-

(1) That studies on the "combination dithizone-spectrographic method" and on the polarographic procedure for the determination of zinc in soils be continued.

(2) That the study of the determination of copper in soils be continued.

(3) That the utilization of carmin as an indicator in the determination of boron content of soils be studied further and that p-nitro benzenazo-1, 8-dihydroxy naphthalene-3, 6-disulphonic acid, or "chromotrope-B," be studied as a suitable reagent for the determination of boron in soils.

(4) That studies on the *pH* in soils of arid and semi-arid regions, based upon soil systems of moisture content representative of air-dried soil, be discontinued.

(5) That further studies on the *pH* of soils at a moisture content approximating the field capacity be carried out.

(6) That the double distillation procedure for fluorine, as set forth in the paper by MacIntire, *et al.*, be made first action.

(7) That the Ca-acetate replacement method of exchangeable hydrogen determination in soil be studied collaboratively in comparison with the ammonium acetate method and with the paranitrophenol method on a number of soils, to be selected as representative of the several types of soil colloids.

(8) That the exchangeable hydrogen indications by these methods be checked through the incorporation of finely divided calcite, and against determined *pH* values of the treated soils after allowing a sufficient period of contact for complete decomposition of the added calcite.

(9) That the survey and comparison of methods for the determination of phosphorus (a), that fraction in "available" state and (b) the proportion of organic-inorganic forms therein, be continued (*This Journal*, 30, 43, (1947)).

(10) That the survey and comparisons of methods for the determination of exchangeable K in soils be continued. (*This Journol*, 30, 44 (1947)).

(11) That the Associate Refereeship on Exchangeable Calcium and Magnesium be maintained.

* For report of Subcommittee A and action of the Association, see *This Journal*, 34, 43 (1951).

REPORT ON HYDROGEN-ION CONCENTRATION OF SOILS

By LANNES E. DAVIS (Division of Soils, California Agricultural Experiment Station, Davis, Calif.), *Associate Referee*

This report consists of two parts: (1) Studies of the *pH* in Soils of Arid and Semi-arid Regions. (2) Report of recent investigations in California.

Special attention was paid to the *pH* of soils with low moisture contents. Soil-water ratios of 1:2, 1:5, etc. were utilized for comparison. Most of the soils were California valley-fill soils of approximately neutral reaction, as shown by a 1:1 soil-water ratio. A Leeds and Northrup potentiometric set-up and a Beckman *pH* meter, Model H, were used with the glass electrodes.

The results confirm those reported by the writer in 1943 (1) and similar results obtained by McGeorge (2) and Chapman (3).

The following trend was noted in the more recent studies.

(a) High moisture contents (soil-water ratios in a range from 1:10 to somewhat above the field capacity).

The *pH* readings were generally higher than at the field capacity and increased as the dilution increased up to soil-water ratios of 1:10. When the glass electrode was left undisturbed in a given mixture for several hours, a series of readings showed fluctuations of 0.1-0.2 *pH* units but no definite trend.

(b) Soil moisture contents in a range close to the field capacity.

In many of the soils the *pH* readings were not appreciably affected by the moisture content. There was no drift in the values recorded when the electrode was retained in the soil.

(c) Soil moisture contents appreciably below the field capacity.

When the glass electrode was pressed into the soil the *pH* value, recorded immediately, was generally lower than at higher moisture contents. This initial reading varied greatly, especially in the drier soils. The glass electrode was retained in the soil, undisturbed. The apparent *pH* values increased with time over a range of 1-3 *pH* units in a 24 hour period.

The evidence described here suggests that probably one can safely measure *pH* values with a glass electrode assembly when the soil moisture content approximates the field capacity, but not in a range appreciably below the field capacity. It is suggested that studies of soils in the air-dry range be discontinued. If the members of the A.O.A.C. so desire, more intensive studies of methods involving soils with moisture contents near the field capacity should be inaugurated. It is particularly desirable to find some means of readily deciding in each case when the soil moisture content is adequate for routine readings of soil *pH* values.

It is necessary to call the attention of those A.O.A.C. members who are concerned with *pH* measurements to recent work done by Hans Jenny and

his group at Berkeley. The Associate Referee has been associated with this group in an advisory capacity for several months and is well acquainted with their investigations. Recently a preliminary report has appeared in *Science*. (4) The results need not be restated here.

These authors regard their results as conclusive and their interpretations as reasonably conclusive; in my opinion the conclusions to be derived must be considered as tentatively suggestive of the following possibilities:

(a) Electromotive force values in soils, and many suspensions, gels, and other colloidal systems *may be* influenced to a *large degree* by the potential at the salt bridge.

(b) The "true" *pH* of many colloidal materials of industrial importance possibly may not be properly determined by existing methods.

(c) The entire problem of *pH* determinations in colloidal materials may have to be examined very carefully.

I recognize that these suggestions are revolutionary and should be accepted only tentatively if at all.

RECOMMENDATIONS*

It is recommended-

(1) That studies on the *pH* in soils of arid and semi-arid regions, based upon soil systems of moisture content representative of air-dried soil, be discontinued.

(2) That further studies on the *pH* of soils at a moisture content approximating the field capacity be carried out.

REFERENCES

- (1) DAVIS, L. E., *Soil Sci.*, 56, 405 (1943).
- (2) MCGEORGE, W. T., *J. Amer. Soc. Agron.*, 29, 841 (1937).
- (3) CHAPMAN, H. D., *et al.*, *Soil Sci. Soc. Amer. Proc.*, 51, 191 (1939).
- (4) JENNY, H., *et al.*, *Science*, 112, 164 (1950).

REPORT ON EXCHANGEABLE POTASSIUM IN SOILS

By A. MEHLIEH (North Carolina Agricultural Experiment Station, Raleigh, N. C.), (*Associate Referee*), and R. F. REITEMEIER and D. D. MASON (Division of Soil Management and Irrigation and Biometrical Services, respectively, U. S. Department of Agriculture, Beltsville, Maryland).

Efforts of the collaborative studies during 1949-50 were concentrated on the influence of extraction techniques with ammonium acetate on the exchangeable potassium, measured by means of the flame photometer.

* For report of Subcommittee A and action of the Association, see *This Journal*, 34, 43 (1951).
 † Associate Referee.

The collaborators were supplied with samples of 15 soils and sufficient glass vials for the shipment of duplicate extracts to Beltsville. Extracts were stored in refrigerators until all of them had arrived, and potassium was then determined by means of a Perkin-Elmer Flame Photometer Model 52-A, using 100 p.p.m. of lithium as lithium chloride for the internal standard. The determinations were made by Reitemeier and R. S. Holmes

TABLE 1.—Effect of NH_4OAc extraction procedures on exchangeable K values, measured by one instrument (m.e. per 100 g of soil)

SOIL NO.	EXTRACTION PROCEDURE										MEAN
	A		A-1	B			C		D		
	COLLABORATOR										
	1	2	2	3	4	5	6	7	8	9	
1	.030	.033	.033	.035	.031	.030	.033	.038	.030	.034	.033
1a	.031	.031	.033	.030	.037	.028	.033	.038	.031	.030	
2	.190	.213	.213	.196	.208	.224	.190	.202	.205	.202	.204
2a	.190	.216	.213	.193	.216	.222	.190	.193	.202	.207	
3	.301	.296	.307	.341	.307	.335	.335	.335	.273	.324	.316
3a	.307	.284	.301	.341	.313	.347	.335	.330	.284	.318	
4	.162	.165	.168	.165	.159	.162	.151	.165	.176	.168	.164
4a	.159	.165	.182	.165	.159	.162	.148	.151	.176	.165	
5	.273	.250	.244	.267	.261	.239	.239	.250	.239	.250	.254
5a	.267	.244	.250	.250	.261	.239	.244	.267	.284	.256	
6	.213	.207	.207	.219	.210	.213	.176	.182	.193	.216	.204
6a	.213	.207	.205	.210	.210	.213	.176	.202	.193	.208	
7	.088	.118	.116	.115	.112	.112	.087	.101	.115	.109	.107
7a	.084	.112	.107	.115	.111	.114	.081	.102	.121	.111	
8	1.45	1.42	1.48	1.54	1.480	1.480	1.340	1.420	1.390	1.360	1.43
8a	1.45	1.39	1.48	1.54	1.450	1.450	1.340	1.450	1.360	1.360	
9	1.12	1.17	1.21	1.15	1.150	1.160	1.110	1.140	1.110	1.120	1.15
9a	1.15	1.18	1.22	1.15	1.140	1.160	1.070	1.150	1.090	1.140	
10	1.31	1.32	1.36	1.340	1.350	1.340	1.290	1.280	1.270	1.280	1.30
10a	1.31	1.27	1.36	1.350	1.340	1.320	1.280	1.070	1.270	1.290	
11	.125	.159	.173	.136	.125	.142	.105	.136	.165	.159	.143
11a	.119	.159	.171	.139	.134	.142	.111	.136	.165	.159	
12	.318	.324	.324	.318	.313	.313	.318	.318	.301	.318	.317
12a	.313	.324	.324	.307	.318	.324	.313	.324	.307	.313	
13	.060	.070	.064	.065	.064	.063	.058	.064	.064	—	.064
13a	.060	.067	.071	.065	.064	.063	.054	.063	.065	—	
14	.142	.145	.151	.119	.148	.159	.134	.165	.145	.128	.144
14a	.136	.153	.162	.125	.148	.159	.136	.154	.142	.131	
15	.041	.040	.043	.041	.040	.040	.041	.043	.044	.044	.042
15a	.037	.043	.045	.038	.045	.038	.040	.041	.045	.040	

TABLE 2.—Effect of *NH₄OAc* extraction procedures on exchangeable K values, measured by different instruments (m.e. per 100 g soil)

SOIL NO.	EXTRACTION PROCEDURE								
	A		B	C		D			
	COLLABORATOR								
	1	7	5	6	7	6	7	7*	8
1	.064	.040	.026	.051	.035	.051	.032	.040	.036
1a	.064	.040	-	.051	.030	.063	.030	.036	.037
2	.225	.240	.282	.230	.210	.230	.227	.229	.288
2a	.225	.235	-	.230	.205	.230	.227	.235	.275
3	.272	.325	.410	.338	.345	.320	.345	.351	.340
3a	.287	.325	-	.339	.345	.318	.338	.351	.340
4	.192	.185	.243	.173	.190	.179	.206	.210	.207
4a	.192	.185	-	.186	.170	.186	.206	.210	.210
5	.240	.254	.282	.249	.250	.256	.257	.250	.288
5a	.240	.238	-	.230	.240	.243	.252	.250	.269
6	.225	.230	.320	.205	.205	.202	.246	.250	.247
6a	.225	.225	-	.205	.210	.192	.242	.235	.246
7	.128	.113	.166	.115	.100	.102	.115	.135	.150
7a	.128	.113	-	.102	.090	.102	.115	.135	.150
8	1.22	1.46	1.51	1.15	1.33	1.09	1.42	1.43	1.47
8a	1.22	1.48	-	1.15	1.33	1.09	1.42	1.43	1.48
9	.896	1.18	1.25	.88	1.02	.83	1.17	1.23	1.18
9a	.910	1.14	-	.86	1.03	.83	1.17	1.25	1.20
10	1.06	1.34	1.37	1.02	1.15	.98	1.29	1.36	1.29
10a	1.06	1.33	-	1.02	1.00	.98	1.29	1.36	1.31
11	.143	.168	.192	.147	.145	.147	.180	.197	.251
11a	.143	.168	-	.153	.152	.147	.180	.195	.256
12	.272	.330	.358	.332	.330	.294	.327	.330	.365
12a	.272	.330	-	.315	.315	.294	.327	.330	.371
13	.079	.066	.077	.068	.060	.063	.073	.080	.095
13a	.079	.066	-	.069	.075	.063	.075	.080	.096
14	.128	.172	.205	.160	.175	.160	.191	.200	.189
14a	.128	.170	-	.160	.165	.160	.180	.192	.189
15	.064	.047	.038	.064	.045	.063	.053	.060	.060
15a	.064	.047	-	.064	.035	.063	.057	.060	.061

* Aliquot from D-7 following oxidation of organic matter.

between January 27 and February 2, 1950. The results of these analyses are shown in Table 1.

The collaborators were also asked to determine potassium on portions of their extracts using their own instruments. Not all of the collaborators were in a position to do this. The results submitted are shown in Table 2. In all cases, duplicate 20 gram portions of soil were used and a single value reported for each extract.

The extraction procedures used were as follows:

A. 20 g of soil was placed in a suitable funnel and leached with 200 ml of *N* NH.OAc, the rate adjusted so as to require at least 4 hours for passage of the solution, and then made up to 200 ml with NH.OAc.

A-I. Like A, except that 100 ml of 1 *N* NH.OAc was pipetted onto the soil contained in a leaching funnel with no rate control. The following day a second 100 ml portion was added in a similar manner.

B. 20 g of soil was placed in an Erlenmeyer flask, 50 ml of *N* NH.OAc was added, shaken for 30 minutes, allowed to stand overnight, transferred to a 7 em Buchner funnel, filtered with gentle suction, the flask rinsed, and the soil leached with 150 ml of NH.OAc in small portions, and made up to 200 ml with NH.OAc.

C. 20 g of soil was placed in an Erlenmeyer flask, 50 ml of *N* NH.OAc was added, shaken for 30 minutes, transferred to a 7 em Buchner funnel, the flask rinsed, and the soil leached with 40 ml of NH.OAc in small portions, and made up to 200 ml with NH.OAc.

D. Extraction procedure the same as C, except that 2 *N* NH.OAc was used and the volume made up first to 100 ml with 2 *N* NH.OAc and finally to 200 ml with H₂O.

The values of Table 1, all determined on the same photometer, were subjected to analysis of variance. This indicated significant differences among the five extraction procedures. The means for the procedures, in alphabetical order, are 0.390, 0.407, 0.400, 0.378, and 0.383 m.e. potassium per 100 grams. Significant differences exist between A and B procedures on one hand, and C and D procedures on the other. In addition, the soils-by-procedure interaction was highly significant, which indicates a differential effect of procedures on different soils. Separate analyses were then made on the group of three soils having the highest levels of potassium, namely, 8, 9, 10, and of the 12 remaining soils, whose values are considerably lower. Analysis of the high level group indicated significant differences between procedures. The mean values were 1.295, 1.352, 1.327, 1.245, and 1.253. These means are in the same order as those for the entire group of 15 soils, and the indicated grouping with respect to significant differences is identical with that given for the complete analysis. The analysis of the group of remaining 12 soils, with means of 0.164, 0.171, 0.168, 0.161, and 0.166, indicated no significant difference due to procedure.

Conclusions based on these three analyses include the following: (a) different operators extract substantially equal quantities of K when using the same extraction procedure; (b) for soils of low to medium exchangeable

K level, the five different procedures remove substantially equal amounts of K; and (c) for soils containing 1-1.5 m.e. of exchangeable K per 100 grams of soil, the difference in quantity of K removed by the different procedures may range up to 8%. The explanation for differences between procedures on soils of high K level may involve two factors; namely, (a) in the two most effective procedures, A-I and B, the soil was in contact with a portion of the extractant for at least an overnight period and (b) in the two least effective procedures, C and D, the soils were leached with the smallest volume of extractant and presumably for the shortest periods of time. These three soil samples originated from the Great Plains region, and a portion of the extracted K possibly was removed from unweathered K-bearing minerals by the solvent action of ammonium acetate solutions. Extraction by 2 N ammonium acetate appears to extract no more K than a 1 N solution under the same conditions.

The effect of extraction procedure on values of K measured by different analysts using different instruments is shown by the results in Table 2. The data under procedure A-I, B-5, and C-7 were obtained on portions of the same extracts reported in the corresponding columns of Table 1. All of the other results reported in Table 2 were obtained from separate extracts. The results in Table 2 show in general more variation between procedures and collaborators than those in Table 1. Low results are reported by collaborators 1 and 6 for soil numbers 8, 9, and 10. High results are reported by collaborator 5 with a large number of soils and by No. 8 with a few soils.

The analyses by collaborators 5 and 8 were made with a Perkin-Elmer Model 18 flame photometer with no provision for the use of an internal standard. Calcium and magnesium in soils are known to influence the measurement of potassium. To reduce these effects, the addition of magnesium acetate to both the standards and extracting solution has been suggested (*Soil Science Soc. Amer. Proceedings*, 11, 221-226, 1947). Hence, the collaborators using this instrument added magnesium acetate to ammonium acetate *after* extraction as well as to the standards. The results seem to indicate that with some of the soils used in the study, the addition of magnesium did not fully eliminate the effect of the other associated cations. This assumption is supported by the results obtained by collaborator 6. In his D extractions he added magnesium acetate to the ammonium acetate before extraction but employed lithium chloride as the internal standard (compare C-6 and D-6, the latter with Mg).

The effect of removing organic matter from extracts prior to photometric determination was examined by analysis of variance of the D-7 and D-7* values of Table 2. Two analyses were made, one for all 15 soils, the other for the 12 low level soils. Both analyses indicated that removal of organic matter effected a significant increase in K values. However, the mean values, 0.408 and 0.423, indicate an average difference of only

about 4%. The lack of appreciable effect of the treatment is in agreement with previously reported results (*This Journal*, 32, 371 (1949); readers should compare the results of collaborator 6, procedure B, organic matter not removed, with procedure F, organic matter removed.)

The following conclusions appear warranted by the collaborative study: (a) for soils of low to medium exchangeable K level, variable factors in extraction with ammonium acetate, such as concentration, period of contact, volume of extractant, and shaking provide only minor effects on the quantity of K extracted; (b) for soils of high exchangeable K level, increases in period of contact and volume of extractant effect measurable increases in the amount of K extracted; (c) removal of organic matter from the extract prior to photometric determination of K is not justified; (d) the addition of magnesium to the extract prior to or following the extraction in general is unnecessary; (e) different operators using the same extraction procedure extract substantially equal amounts of K from a soil; and (f) the variation in results by different analysts and analytical procedures on extracts which have been shown to be quite uniform is so great that the reasons for the lack of agreement should be investigated. In the employment of a procedure similar to C or D a 10 gram sample is preferable, particularly with soils of high clay content. It is further recommended that these studies be extended to involve the use of other extracting solutions as well as the determination of K with cobaltinitrite.

Grateful acknowledgement is made of the following for their active

TABLE 3.-Soils used in the collaborative study of potassium

SOIL NO.	SOIL TYPE	pH*	CONTRIBUTOR
1	Leon fine sand, Florida	4.2	N. Gammon, Jr.
2	Sassafras silt loam, New Jersey	4.2	E. R. Purvis
3	Agawam fine sandy loam, Massachusetts	5.1	D. H. Sieling
4	Miami silt loam, Wisconsin	6.0	O. J. Attoe
5	Orangeburg fine sandy loam, Mississippi	5.3	C. L. Blount
6	Putnam silt loam, Missouri	6.0	E. R. Graham
7	Harpster clay loam, Iowa	7.6	W. H. Allaway
8	Holdredge silt loam, Nebraska	6.2	H. F. Rhoades
9	Amsterdam silt loam, Montana	7.4	A. H. Post
10	Colby silt loam, Kansas	7.7	R. V. Olson
11	Brookston silty clay, Indiana	5.5	J. L. White
12	Kirkland silty loam, Oklahoma	4.8	H. J. Harper
13	Georgeville silty clay loam, N. Carolina	4.5	A. Mehlich
14	Craven very fine sandy loam, N. Carolina	6.3	A. Mehlich
15	Norfolk sand, North Carolina	5.0	A. Mehlich

* Determined by Dr. E. R. Graham with the glass electrode, using a 1:1 soil:H₂O ratio.

participation in this study: O. J. Attoe and C. Wong, University of Wisconsin; N. Gammon, Jr., University of Florida; E. R. Graham, University of Missouri; R. S. Holmes, U. S. Department of Agriculture; R. R. Hunziker, Iowa State College; U. S. Jones, Mississippi Agricultural Experiment Station; E. H. Tyner, University of Illinois; M. E. Weeks, University of Kentucky.

The names of the contributors of the soils used in this study, the soil type, and pH are presented in Table 3.

REPORT ON LIMING MATERIALS AND EXCHANGEABLE HYDROGEN IN SOILS

By W. M. SHAW (The University of Tennessee Agricultural Experiment Station), *Associate Referee*

Following the recommendation adopted at the 1949 meeting of the Association: "That the 2-point barium hydroxide-barium acetate titration procedure for the determination of exchangeable hydrogen in soils be studied further in relation to calcite equilibria in a variety of soils," the Associate Referee carried out investigations on a number of soils with the barium hydroxide titration of soil suspensions in 0.5 M barium-acetate, and with calcite decompositions through direct contact with soils. The soils were selected to represent the distinct groups of soil colloids, namely the organic, kaolinitic, and montmorillintic clays,

The Associate Referee also cooperated with the committee on chemical analyses of the Soil Science Society of America, at request of its chairman, A. Mehlich, and under the general supervision of the Referee on Soils and Liming Materials, W. H. MacIntire. The methods of exchangeable hydrogen determination suggested to the Associate Referee for investigation were:

1. Ammonium acetate, pH 7 (3).
2. Paranitrophenol-Ca-acetate buffer, pH 7 (5).
3. Titration with Ba(OH). to pH 7 of soil suspensions in 0.5 MBa-acetate, pH 7, (4).
4. Triethanolamine BaCl. buffer, pH 8.1 (2).
5. Ca(OH).-air equilibration, a modification of original Bradfield and Allison method (2, 1).

The Associate Referee has completed exchangeable hydrogen determinations on the 8 soils submitted by Dr. Mehlich and bearing the number 1-6, 13, and 14, using methods 2, 3, 4, and 5.

It is regretted that the prospective collaborators, with the exception of Dr. Mehlich, either made no report or in some instances made inadequate reports on the methods under study. Mehlich reported on Methods 4 and 5. The Associate Referee deemed the present data insufficient for presentation as a report on collaborative results. It is hoped that greater progress

will be achieved the following year, and that a joint report of the cooperating organizations can be made.

In the meantime the work of the Associate Referee was extended into a comparative study of other methods of effecting hydrogen replacement and determination of the replaced hydrogen, the objective being to find a simple and precise procedure that could be adopted as a routine method for determinations in large numbers. The results of such a study, along with some extensive investigations of the soil-calcite reaction, are being presented separately¹ as a contributed paper at the 1950 meeting of the Association.

In the opinion of the Associate Referee, none of the methods investigated, with the exception of the paranitrophenol buffer method, is adapted to use in routine determinations. The paranitrophenol buffer method, although very rapid, does not possess sufficient precision and gives results not in accord with those obtained by other methods of the same class. The Associate Referee has found the method of replacement with 0.5 *M* calcium-acetate at *pH* 7 to be equally as accurate and more expeditious than the barium hydroxide-2-point titration procedure that was described in earlier reports. A description of this procedure is given herewith and is proposed as a substitute for the previously recommended method.

THE CALCIUM ACETATE METHOD REAGENTS

(1) 0.5 *M* *Ca-acetate*.—Prepare 0.5 *M* calcium acetate by dissolving 176.1 g $\text{Ca}(\text{C}_2\text{H}_3\text{O}_2)_2 \cdot \text{H}_2\text{O}$ in 2 liters of H_2O ; adjust to *pH* 7 by titration with 1 *N* acetic acid, using the glass electrode as indicator. Approximately 4 ml of the acid will be required per 2 liter. Make supply necessary for a week at a time, store in bottle provided with syphon and soda-lime tube.

(2) 0.1 *N* *Ba(OH)*.—Dissolve 1/20 molar wt. of $\text{Ba}(\text{OH})_2 \cdot 8\text{H}_2\text{O}$, C.P. per liter, allowing a 2% excess for impurities and CO_2 contamination. Let stand 24 hours. Prepare a storage bottle connected with syphon and soda-lime guard tube and freed of CO_2 . Draw $\text{Ba}(\text{OH})_2$ soln into the prepared bottle by applying suction at the soda-lime tube and drawing the soln thru a sintered glass filter. Connect the $\text{Ba}(\text{OH})_2$ soln with a 25-ml pinch cock burette, provided with side tube, for gravity feed, and a soda-lime tube at the top.

DETERMINATIONS

Weigh soil charges calculated to contain 1 to 2 m.e. of exchangeable hydrogen; place in 250 ml Erlenmeyer flasks; introduce ca 100 ml of the replacing soln; stopper and shake several times during first hour. Let stand overnight. Filter soil suspension thru 12.5 cm filter papers, placed on 3-inch funnels that lead into 250-ml volumetric flasks. Transfer soil onto filter by the aid of stream of the replacing solution; wash the soil with small quantities of the solution until the volume is just below the 250 ml mark. Remove funnel, discard soil and make filtrate to volume by means of the replacing solution. Transfer to 400-ml beaker; rinse flask with H_2O and titrate potentiometrically with $\text{Ba}(\text{OH})_2$ to *pH* 8.8. Obtain also the titration value of

¹ Shaw, W. M., and MacIntire, W. H., *This Journal*, 34,471 (1951).

250 ml of the replacing soln. Calculate the exchangeable hydrogen in m.e. per 100 g of soil from the formula: $[(Tu-Tb)/Wt.]10$, in which

Tb = titration value of replacing soln

Tu = titration value of soil extract, both expressed in ml of 0.1 N Ba(OH).

Wt. = weight of soil charge.

RECOMMENDATIONS

It is recommended-

(1) That the Ca-acetate replacement method for the determination of exchangeable hydrogen in soil be studied collaboratively, in comparison with the ammonium acetate method and with the paranitrophenol method on a number of soils that will represent the several types of soil colloids.

(2) That the exchangeable hydrogen indications by these methods be tested by the incorporation of finely divided calcite, and the determination of the *pH* values of the treated soils be made, after allowing a sufficient period of contact for complete decomposition of the added calcite.

REFERENCES

- (1) BRADFIELD, R., and ALLISON, W. B., "Criteria of Base Saturation of Soils." *Trans. Second Commission Intern. Soc. Soil Science*, pp. 63-79, 70 (1933).
- (2) MEHLICH, A., "Determination of Cation and Anion-Exchange Properties of Soils." *Soil Science*, 66, 429-445 (1948).
- (3) PEECH, M., ALEXANDER, L. T., DEAN, L. A., and REED, J. F., "Methods of Soil Analysis for Soil Fertility Investigations," U.S.D.A. Cir. 757 (1947).
- (4) SHAW, W. M., "Determination of Exchangeable Hydrogen and Lime Requirement of Soils" *This Journal*, 32, 437 (1949).
- (5) WOODRUFF, C. M., "Testing Soils for Lime Requirement by Means of a Buffered Solution and Glass Electrode." *Soil Science*, 66, 53 (1948).

REPORT ON FLUORINE

THE DIRECT DOUBLE DISTILLATION PROCEDURE* FOR THE DETERMINATION OF THE FLUORINE CONTENT OF SOILS

By W. H. MACINTIRE (*Associate Referee*), L. J. HARDIN, and L. S. JONES
(The University of Tennessee Agricultural Experiment Station),
Knoxville, Tenn.

Until recent years, the fluorine content of soils was not deemed important enough to warrant the prescribing of an analytical procedure for its determination. Although, since 1933, it has been feasible to determine the fluorine contents of distillates by means of the Willard-Winter titration procedure (11) and of its modification (2) and in microproportions by means of the Sanchis procedure (9), there was no certainty that the stipulated perchloric acid distillation would effect complete expulsion of the fluorine content of soils. The present requirement is to determine

* As detailed in the accompanying directions. "Direct" is used to connote and emphasize that the distillation is from untreated soil.

whether the fluorine of native soil minerals and the fluorine of incorporated materials will be dispelled completely when analytical charges of "raw" soil, and those limed and calcined briefly at 500°C., are subjected to distillation from sulfuric acid solution-suspension at 165°C.

In the procedure for the determination of the fluorine content of soils, as in the *Book of Methods* (1) and elsewhere (3,8), it is prescribed that an analytical charge of soil be fortified through an inmixing of a calcium caustic as prefatory to the step of incineration and calcination (a) to preclude loss of fluorine during that step and (b) to assure that the fluorine content of the resultant calcine will be in form readily distillable from perchloric acid at ca. 135°C. In the cited references, 900°C. is prescribed as ultimate temperature of calcination.

In previous A.O.A.C. studies, full recovery of the fluorine of incorporated fluorine materials was obtained by means of perchloric acid distillations from soils that were fortified with adequate proportions of calcium peroxide and calcined at 500°C. and then at 900°C. In contrast, only partial recoveries of fluorine were obtained from like calcines of soils into which magnesium had been mixed as either peroxide or nitrate, although full recoveries were obtained in the distillates from incinerates from fluoride-fortified organics plus magnesium peroxide (4). It should be noted also that complete recoveries of fluorine were not obtained through distillations from a fused mixture of soils and carbonates of potassium and sodium. In those studies, and in the subsequent work, the perchloric acid distillations were expedited through the use of a current of steam as suggested by related work (4, 7), in lieu of the original drop-wise technique of Willard and Winter (11).

After workers in foreign countries had reported difficulties in obtaining calcium oxide having low content of fluorine, calcium hydroxide was substituted for the peroxide in further studies. Those studies also related the effects that variations in temperature and duration of calcination exerted upon recoveries of fluorine from soils into which different fluorine carriers had been incorporated annually during a 10-year lysimeter experiment (6). The present authors found that 900°C. calcination of limed charges of soil caused fluorine losses up to complete dissipation of known content (6).

These several studies resulted in findings that necessitated certain modifications as to the calcination of the soil charges for their subsequent distillation from perchloric acid and prompted three Referee recommendations in 1949:

"That the analytical technique previously proposed for ignition of charge and distillation of fluorine therefrom be studied collaboratively."

"That a study be made as to the adequacy of Ca(OH)₂ as a fixative for fluorine in soil charges of 1 to 1 proportion with calcination at 500°C. in 5 to 60-minute periods."

"That the direct distillation of unignited soil with H_2SO_4 at $165^\circ C.$ with sequential $HClO_4$ distillation of the concentrated collection at $135^\circ C.$ be studied collaboratively."

The present contribution deals further with the utility of direct distillation from sulphuric acid on both "raw" soils and their lime-fortified calcines, in lieu of the two presently prescribed steps, i.e., calcination of calcium-fortified mixtures and perchloric acid distillation therefrom.

EXPERIMENTAL FINDINGS

In compliance with the quoted 1949 recommendation as to collaboration, the samples and analytical findings given in Table 1 were exchanged with Robinson and Edgington of the Bureau of Plant Industry, Soils, and Agricultural Engineering of the U. S. Department of Agriculture. Half-gram charges of soils and corresponding calcines of lime-slurried and dried charges were used for the sulfuric acid distillations at $165^\circ C.$ that were collected in alkaline solution and then concentrated for perchloric acid distillation at $135^\circ C.$ The sulphuric acid and perchloric acid distillations were compared with single perchloric acid distillations from like charges of soil plus 4 grams of calcium peroxide that had been calcined 2 hours at $800^\circ C.$, as in footnote (b) of Table 1. Thus, on one hand, the fluorine recoveries from 0.5-gram charges of soils by double distillation are compared to the recoveries by means of such distillation from like charges that had been slurried with milk of lime and dried prior to their calcination at $500^\circ C.$, and, secondly, the recoveries obtained by means of those two techniques are compared to the recoveries obtained by Edgington by means of perchloric acid distillation from like charges that had been mixed with 4 grams of calcium peroxide and then calcined 2 hours at $800^\circ C.$

The 26 soils designated in Table 1 were from many areas and were selected to represent diversity of type and composition, with resultant range of 37 p.p.m. to 2172 p.p.m. in fluorine content. In 23 cases the recoveries of fluorine by means of the direct sulfuric acid distillation of the 0.5-gram charges of raw soils were greater than the recoveries from the corresponding calcines that were resultant from the 5-minute $500^\circ C.$ heating of 0.5-gram charges of soil plus calcium oxide in equal quantity. In some cases, the disparities in recovery were not appreciable; in other cases, however, the differences were as much as 100 per cent. Higher recoveries were registered by the direct distillations from sulfuric acid in 14 of the 18 comparisons between the recoveries obtained through the sulfuric acid distillations of the raw soils and recoveries obtained by Edgington through perchloric acid distillations from the soil-calcium oxide calcines. In the 18 comparisons between recoveries by means of the double distillation of the 1+1 soil-calcium oxide calcine and recoveries by means of the single perchloric acid distillation of the soil-calcium

TABLE 1.—Fluorine content of soils

SOILS USED		DIRECT DOUBLE DISTILLA- TION ^a	DOUBLE DISTILLA- TION FROM SOIL+CaO ^b	A.O.A.C. PRO- CEDURE ^{c,e}
SOURCE	ORGANIC MATTER CONTENT			
	<i>per cent</i>	<i>p.p.m.</i>	<i>p.p.m.</i>	<i>p.p.m.</i>
Hartsells Silt Loam (S-1410)		169	121	—
Clarksville Silt Loam (S-1411)		160	78	—
Colbert Clay subsoil, Knox County (S-1412)		1276 ^d	1103	—
Clarksville Soil, Ca ₂ (PO ₄) ₂ 10-yr. addition, Tenn. #7162 (S-1431)		155	134	—
Clarksville Soil, Ca ₂ (PO ₄) ₂ +CaF ₂ 10-yr. addition, Tenn. #7163 (S-1432)		1361 ^d	1377	—
Maury Silt Loam, Ky. Exp. Sta. Lexing- ton, Ky. 1949 (S-1420)		1460 ^d	1084	—
Maury Silt Loam, MTES, Tenn. 1949 (S-1421)		377	348	—
Talladega Macaceous Clay (?) (S-1422)		440	374	—
Chester Loam, 26"-38", Rockville, Md. USDA 3319 (S-1423)		395	368	371
DeKalb Silt Loam, 0"-8" 7.6 mi. S. of Hay- field, Va., USDA 491248 (S-1424)		441	393	420
Caribou Loam, 0"-2" Aroostook Co. Me., USDA 49418 (S-1425)	16.3	237	240	265
Frostburg 0"-2½" Maryland USDA C1605 (S-1426)	10.1	72	37	36
Amelia, Va. 0"-1" USDA C2577 (S-1427)	29.2	257	239	300
Nacagdoches, A horizon, Tyler, Tex. USDA C3907 (S-1428)	0.2	75	67	75
Carrington Loam, 0"-3" Winthrop, Iowa USDA C2916 (S-1429)	6.1	230	199	201
"El Peladero," Province of Boyaca, Columbia, S.A. E1381 (S-1430)		458	455	384
Muck, 0"-36" Jones Co., N.C. USDA C311 (S-1413)	21.1	70	62	22
Muck, 40"-60" Jones Co., N.C. USDA C312 (S-1414)	0.8	132	102	113
Muck, 0"-36" Jones Co., N.C. USDA C313 (S-1415)	12.3	115	37	65
Houston Black Clay, Texas USDA 6096 (S-1416)	1.0	375	352	352
Muskingum Silt Loam, 0"-7" Zanesville, Ohio USDA B407 (S-1417)	1.9	363	349	348
Hagerstown Silt Loam, 0"-6" Bland Co., Va. USDA 461156 (S-1418)		657	589	644
Hagerstown Silt Loam, 13"-34" Bland Co., Va. USDA 461148 (S-1419)		2172 ^d	1970	2125
"Superstition" sand, surface, Yuma, Ariz. USDA 50135 (S-1433)		139	120	137
Conowing Soil, 0"-4" Cherry Hill, Md. USDA 6178 (S-1434)	1.6	168	126	178
Arredonda Fine Sand, 0"-36" Gainesville, Fla. USDA C6331 (S-1435)		37	40	21

^a Direct double distillation of 0.5-g charge of untreated soil; 500 ml collection from H₂SO₄ at 165°C.; distillate concentrated and subjected to HClO₄ distillation at 135°C.

^b Double distillation of 0.5-g charge mixed with 0.5 g CaO and 5 min. incineration at 500°C.; 500 ml. collection of distillate from H₂SO₄ at 165°C. and second distillation as in (a).

^c Single HClO₄ distillation of 0.5-g charge of soil at 135°C. after addition of 5 g of CaO₂ and 2-hour incineration at 800°C. 500 ml distillate collected.

^d Charge of 0.2 g used.

^e Analyses by G. Edgington at Soil Laboratory, Bur. of Plant Ind., Tennessee Agricultural Experiment Station.

oxide calcine, only 5 values were higher by the double distillation of the soil-calcium oxide calcine.

In the sulfuric acid distillations from the several soils whose contents of phosphate and fluorine were attributable to apatite, the recoveries of fluorine from the charges of raw soil were greater than the recoveries from the corresponding charges that had been limed with equal charges of calcium oxide and calcined at 500°C. Since complete evolution of the fluorine content of analytical charges of apatite has been found to be effected by distillations from perchloric acid, it appears that the prior calcination of limed soil of high phosphoric acid and fluorine content is not necessary or advisable in sulfuric acid distillations, whereas mere incinerations of limed charges of soil would be sufficient when distillations are from perchloric acid.

Little is known as to whether occurrences of fluorine in the soil are attributable entirely to minerals of known identity or partly to organic combinations in soils of high content of organic matter. Upon assumption that, at times, the fluorine content of soils occurs in organic combinations, the expectancy would be that such contained fluorine would be converted into inorganic precipitates through biochemical processes of oxidation and disintegration. It is probable that the fluorine of such recently generated fluorides probably would undergo distillation more readily than the fluorine content of minerals native to the soil.

When separates of the soil minerals that contain fluorine are subjected to direct distillation from sulfuric acid, the minerals differ in the readiness with which they release their fluorine content. Hence, it may be that traces of the fluorine of nugatory occurrences of residual minerals may be resistant to distillations from sulfuric acid and from perchloric acid. But, the inertia of such possible minute residua would preclude their being of any determinable effect in the soil system. Because of the factors of meagerness and inertia of such possible recalcitrant residua, the prescribed technique can be rated as effecting virtually absolute expulsion of the fluorine content of soil charges.

As noted, the recoveries of fluorine from the charges of raw soils of high phosphate content by means of sulfuric acid distillation were higher than those obtained from the calcines of the lime-fortified charges, whereas complete recoveries of the fluorine content of rock phosphate have been effected through direct distillations from either sulfuric acid or perchloric acid. Therefore, the partial recoveries of the fluorine from the calcines of the lime-fortified charges of the highly phosphatic soils appear attributable to loss of fluorine during their calcination.

Besides assuring a high degree of accuracy for the determination of fluorine content of soils, the prescribed direct sulfuric acid distillation of untreated charges and complementary perchloric acid distillation from the initial distillates (collected in sodium hydroxide solution and then

concentrated) possesses certain advantages over the 2-step procedure of incineration-calcination of the limed charges of soil and the perchloric acid distillation from the resultant calcines. Because of the necessity that soil calcines be stabilized through high proportions of a calcium caustic, the dissolving of those calcines by the distillation acids results in systems that contain excessive concentrations of solutes. The sulfuric acid procedure also eliminates the problem of obtaining pure calcium oxide or calcium peroxide, through purchase or through laboratory preparation. The sulfuric acid procedure also fits better into operations conducted in laboratories devoid of an electric furnace and attendant temperature controls, and where fluorine determinations are made daily on many samples of soils.

Because of the cited findings to the effect that soil charges will undergo losses of fluorine during calcination, unless adequate excess of inmixed lime be provided and limitation of temperature and duration are assured, it seems advisable to eliminate the conventional prefatory step of calcination when the double distillation procedure is used for the determination of the fluorine content of soils. The present findings serve to substantiate the conclusions reached through previous Referee studies, to the effect that "full recovery of fluorine content of rock-derived soils is effected by direct sulfuric acid distillation of the charge of unignited soil" and "since it assures (a) full recovery of fluorine, (b) obviates the use of a fixative, (c) eliminates incineration and calcination, and (d) is more expeditious than the peroxide procedure, the direct distillation technique is deemed as meritorious and even preferable to the presently accepted procedure, which prescribes that a mixture of soil and calcium oxide be calcined at 500°C., and further at 900°C., as prefatory to the distillation with perchloric acid."

It is now being recommended* that the direct double distillation procedure be prescribed as the "first action," procedure, in lieu of the present paragraphs 3.31 and 3.32 under "Soils," p. 40, Seventh Edition.

PROPOSED METHOD

REAGENTS

- (a) *Buffer Soln.-Dissolve* 9.448 g monochloroacetic acid in 50 ml water and add 2 g NaOH dissolved in 50 ml water.
- (b) *Sodium alizarin sulfonate indicator.--0.05%* aqueous solution.
- (c) *Thorium nitrate soln.--0.02 N* aqueous soln; titrate against standard NaF soln and prepare a standard curve. (Titration solns of 0.01 N and 0.05 N are desirable for low and high fluorine values, respectively.)

DETERMINATION

For soils of high F content, use 0.5-g charge; for those low in F, use 1 g. Transfer soil charge into 125-ml Claisen flask fitted with thermometer and steam inlet tube. Connect flask to condenser provided with delivery tube which dips below surface

* For report of Subcommittee A and action of the Association, see *This Journal*, 34,44 (1951).

of a few ml of dilute NaOH in 600 ml beaker. Moisten charge with 5 ml of water and add 50 ml of 1+1 H₂SO₄. Close flask; apply heat and raise temperature to 165°C. Introduce steam current and collect 500 ml of distillate, which should be kept slightly alkaline to phenolphthalein by addition of dilute NaOH soln. Concentrate distillate to 10-15 ml and transfer to Claisen distillation flask. Add 25 ml 70% HClO₄ containing 0.2% Ag₂SO₄ and steam distill at 130°C.-135°C. Collect ca 200 ml of distillate in a wide-mouth Erlenmeyer flask and make to volume in volumetric flask.

Introduce 25 ml aliquot into 150 ml beaker; dilute 100 ml with distilled H₂O. Add 2 ml of sodium alizarin sulfonate soln; neutralize with .05 N NaOH until pink color appears and then add 1 ml of the buffer soln. Titrate with .02 N Th(NO₃)₄ to faint salmon-pink color. Calculate the results by means of the curve and express as p.p.m. fluorine.

REFERENCES

- (1) A.O.A.C., *Methods of Analysis*.
- (2) HAMMOND, J. W., and MACINTIRE, W. H., *This Journal*, 23, 398 (1940).
- (3) MACINTIRE, W. H., *Soil Science*, 59, 105 (1945).
- (4) — — — and HAMMOND, J. W., *This Journal*, 22, 231 (1939).
- (5) — — — and PALMER, G., *Ibid.*, 31, 419 (1948).
- (6) — — —, JONES, L. S., and HARDIN, L. J., *Ibid.*, 33, 653 (1950).
- (7) REYNOLDS, D. S., KERSHAW, J. B., and JACOB, K. D., *Ibid.*, 19, 156 (1936).
- (8) ROBINSON, W. O., and EDGINGTON, G., *Soil Science*, 61, 341 (1946).
- (9) SANCHIS, J. M., *Ind. Eng. Chem., Anal. Ed.*, 6, 134 (1934).
- (10) WICHMANN, H. J., and DAHLE, D., *This Journal*, 16, 620 (1933).
- (11) WILLARD, H. H., and WINTER, O. B., *Ind. Eng. Chem., Anal. Ed.*, 5, 7 (1933).

No reports were given on boron; zinc and copper; exchangeable calcium and magnesium; or phosphorous.

No reports were given on standard solutions.

No report was given on radioactivity.

TUESDAY-AFTERNOON SESSION

REPORT ON SPECTROGRAPHIC METHODS

By W. T. MATHEIS (Agricultural Experiment Station, New Haven, Conn.),
Referee

In line with Recommendation 1 in my report for last year,¹ a study of reproducibility of results by different laboratories has been made.

Properly prepared sub-samples of two plant materials (alfalfa and tobacco) were analyzed spectrographically by six reporting collaborators, including two in our own laboratory, using their usual techniques and equipment.

Methods of sample preparation and excitation used by the collaborators are shown in Table 1.

TABLE 1.—*Methods of sample preparation and excitation used by collaborators*

Laboratory 1. Acid solution of ash—no buffer-Spark
Laboratory 2. Material ashed in electrode&-salt buffer-DC Arc
Laboratory 3. Acid solution of ash—salt buffers—DC Arc-Flame
Laboratory 4. Ash with salt+carbon buffer added to electrode&-DC Arc
Laboratory 5. Ash with salt buffer added to electrodes-DC Arc

Because of the great number of individual results involved only the averages have been used in this report. The average percentage error in duplication for each collaborator, as reported for ten of the elements determined in the two samples, is shown in Tables 2 and 3.

TABLE 2.—*Average percentage error in duplication-alfalfa*

LABORATORY	1A	1B	2	3	3	4	5
SAMPLE PREP.	SOL.	BOL.	ASH	BOL.	BOL.	ASH	ASH
EXCITATION	SPARK	SPARK	DC ARC	FLAME	DC ARC	DC ARC	DC ARC
K	1.7	6.6	x	4.7	x	x	x
Ca	2.1	1.3	9.7	1.8	x	x	x
Mg	2.1	3.3	10.4	x	18.9	x	x
P	2.7	2.8	6.1	x	x	x	x
Mn	3.6	2.6	9.9	x	7.0	4.8	14.9
Fe	8.0	5.8	12.0	x	4.5	5.7	26.2
Al	4.1	2.8	14.2	x	x	9.7	15.7
Na	6.1	4.6	8.9	4.4	x	x	x
Cu	6.1	6.7	10.5	x	5.1	4.8	8.0
B	15.6	10.2	3.2	x	x	8.2	10.0
Average	5.2	4.7	9.4	3.6	8.9	6.6	15.0

¹ *This Journal*, 33, 830 (1950).

TABLE 3.—Average percentage error in duplication—Tobacco

LABORATORY	IA	IB	2	3	3	4	5
SAMPLE PREP.	SOL.	SOL.	ASH	SOL.	SOL.	ASH	ASH
EXCITATION	SPARK	SPARK	DC ARC	FLAME	DC ARC	DC ARC	DC ARC
K	2.7	3.1	x	1.6	x	x	x
Ca	3.8	2.4	5.0	0.3	x	x	x
Mg	2.4	1.4	3.4	x	17.9	x	x
P	2.0	3.2	8.4	x	x	x	x
Mn	1.9	3.0	6.9	x	4.9	4.8	29.3
Fe	2.7	3.2	10.2	x	7.4	3.8	11.9
Al	3.0	2.1	13.2	x	x	2.5	19.0
Na	3.3	7.6	7.3	4.0	x	x	x
Cu	8.3	2.9	5.9	x	15.7	3.0	20.0
B	4.5	6.2	5.0	x	x	3.9	14.5
Average	3.5	3.5	7.3	2.0 ¹	11.5	3.6	18.9

Over-all averages for the two materials, shown in Table 4, indicate to some extent, at least, the comparative merits of the various techniques.

TABLE 4.—Over-all Average Percentage Error in Duplication

LABORATORY	IA	IB	2	3	3	4	5
SAMPLE PREP.	SOL.	SOL.	ASH	SOL.	SOL.	ASH	ASH
EXCITATION	SPARK	SPARK	DC ARC	FLAME	DC ARC	DC ARC	DC ARC
Alfalfa	5.2	4.7	9.4	3.6	8.9	6.6	15.0
Tobacco	3.5	3.5	7.3	2.0	11.5	3.6	18.9
Average	4.4	4.1	8.4	2.8	10.2	5.1	17.0

The relation between the average percentage error and the average maximum percentage deviation is shown for each collaborator in Table 5.

TABLE 5.—Relation of average error to maximum deviation

LABORATORY	IA	IB	2	3	3	4	5
SAMPLE PREP.	SOL.	SOL.	ASH	SOL.	SOL.	ASH	ASH
EXCITATION	SPARK	SPARK	DC ARC	FLAME	DC ARC	DC ARC	DC ARC
Average error	4.4	4.1	8.4	2.8	10.2	5.1	17.4
Av. max. dev.	10.0	10.9	19.4	3.5	23.0	12.6	32.5
$\frac{R'}{atO}$ Dev. Error	x2.28	x2.65	x2.31	x1.25	x2.26	x2.47	x1.87

It is interesting to note that the ratio of average error to maximum deviation is practically the same for five out of the six collaborators using electrical excitation. This would indicate that the maximum deviation results used in this compilation are not erratic in the ordinary sense but represent a pretty true picture of the possible variation inherent in the various techniques.

It is obvious from reference to Tables 1 and 2 that this study has been considerably handicapped by having so few collaborators report on major elements. Also, the number of portions analyzed varied in some cases. I believe, however, that the indications are reasonably valid.

It must be understood that this study has been concerned purely with accuracy of duplication of results. The collaborators were not requested to standardize specifically for these materials. The actual percentages of the various elements reported were quite interesting in this light and the necessity for a proper and uniform means of standardization is glaringly apparent.

In considering the potential accuracy of these techniques from the standpoint of being satisfactory in comparison with chemical analysis it is well to remember that in spectrographic analysis the error usually represents a fixed percentage of the amount of an element being determined. Unless fractional burning or contamination enters into the picture this percentage error for a given technique should be generally the same for all elements.

In the average chemical determination the error is usually more of a constant than a percentage of the amount involved. On this basis it is apparent that a spectrographic technique reproducible within 10% might compare quite favorably, and in some cases be far superior, to chemical procedure on amounts below 0.3%. On the other hand, where amounts up to 5 or 6% are involved a 10% variation would represent extremely poor manipulation by chemical means.

It is recommended* that an attempt be made to unify the percentage results of the present collaborators through the use of common standards.

No reports were made on microbiological methods.

* For report of Subcommittee B and action of the Association, see *This Journal*, 34, 45 (1951).

REPORT ON STANDARDIZATION OF MICROCHEMICAL METHODS

By C. O. WILLITS, *Referee*, and C. L. OGG, *Associate Referee* (Eastern Regional Research Laboratory,¹ Philadelphia 18, Pennsylvania)

COLLABORATIVE STUDIES ON CARBON AND HYDROGEN

In 1948, two samples were analyzed for carbon and hydrogen at 20 different laboratories. A statistical study of the results was reported at the annual A.O.A.C. meeting in 1948 (8), and a further study of the data was presented at the American Chemical Society, Atlantic City meeting, in 1949. In this study, each collaborator analyzed the two samples, following the procedure currently used by him. The methods were all similar in principle, but no two employed the same combination of techniques for the different steps involved. To determine which techniques produced the best results, statistical studies of the results were made. These indicated that larger weight samples, not wiping the absorption tubes, and not replacing the oxygen in the absorption tubes with air produced more accurate results. The statistical studies also showed that the other common variations in the procedures had little if any effect on the results, for example, values obtained by using mechanically operated, electrically heated sample burners did not differ statistically from those obtained by manually operated gas burners.

A method for carbon and hydrogen analysis based on the results of these studies was submitted to the 1950 collaborators. The method employed the techniques which appeared to produce the best results for the three steps found critical in 1948, plus the techniques for the other operations which resulted in the simplest, most easily performed procedure.

The method, described below, and samples of the same two materials analyzed in 1948, nicotinic acid and benzyl-iso-thiourea hydrochloride, were sent to the 1950 collaborators.

CARBON AND HYDROGEN DETERMINATION

REAGENTS

Copper oxide.-Wire form, about 1 mm in diam. and 3-4 mm long; discard material finer than 20 mesh. Ignite at 800-900°C. for 1 hr before placing in combustion tube.

Platinum gauze, 52 mesh.-From three 3X5-cm sections, make 3 rolls, 30 mm long X 7 mm O.D. Boil in 1-1 nitric acid for 15 min and ignite in nonluminous Bunsen burner flame.

Asbestos.-Gooch crucible asbestos; ignite at 800-900°C. for 30 min and store in wide mouth bottles.

Silver.-Fine wire or ribbon; if tarnished reduce in stream of hydrogen at 350-450°C.

¹One of the laboratories of the Bureau of Agricultural and Industrial Chemistry, Agricultural Research Administration, U. S. Department of Agriculture.

Lead dioxide.-Pellets, 1-2-mm diam., special grade for micro analysis; or prepare by digesting commercial grade powder in concentrated nitric acid for 2 hrs, let stand for 1 hr, decant nitric acid, wash with distilled water until free of nitric acid, evaporate to dryness, and cut into 2-mm cubes. Roll cubes in jar to round corners and sieve out powder.

Glass wool.-Pyrex, pliable.

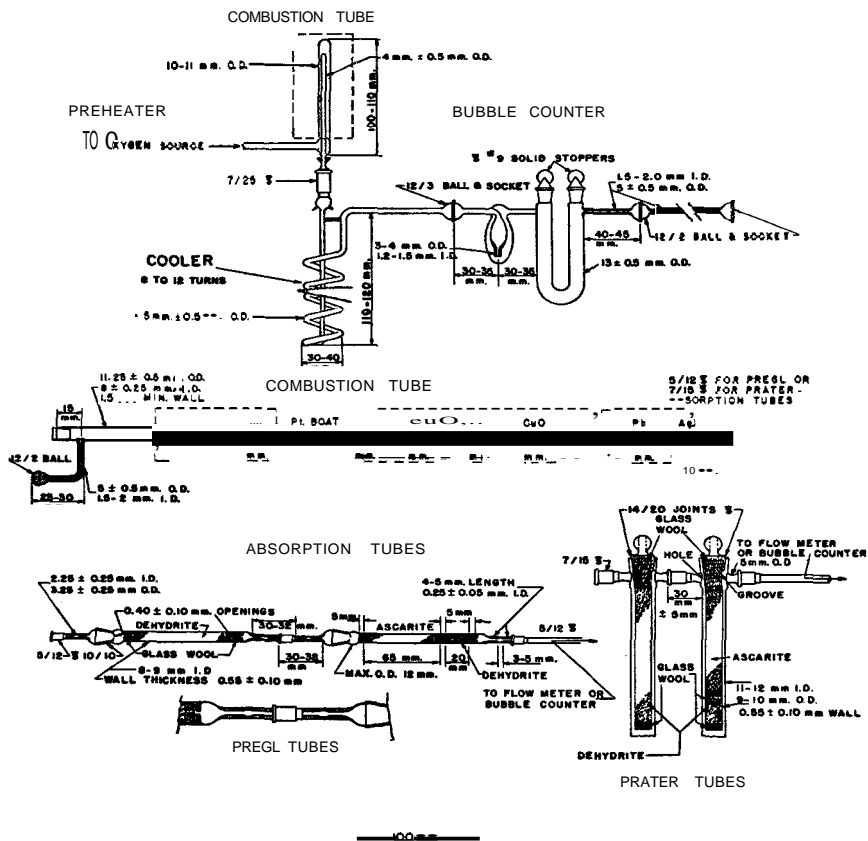

CARBON & HYDROGEN APPARATUS

FIG. 1

Dehydrite or Anhydron.-(Magnesium perchlorate, anhydrous.) Break pieces to less than 3 mm long; discard portion passing 40-mesh sieve.

Ascarite.-(Sodium hydroxide on asbestos.) Use commercial preparation of 8--20 mesh.

Oxygen.-Cylinder with pressure regulator adjustable from 0-10 lb pressure on the low-pressure side and with needle-valve control.

Preheater.-As specified by American Chemical Society Committee on Stand-

ardization of Microchemical Apparatus² except with 12/2 ball joint.'

Bubble counter and U-tube.-According to a A.C.S. specification except with ball joints.'

Combustion tube.-Fused quartz (or Vycor) glass,⁴ dimensions as per A.C.S. specifications⁶ but with 12/2 ball joint' on side arm and 5/12 or 7/15 inner joint³ on exit end.

Absorption tubes.-Pregl type, as per A.C.S. specification, but with 5/12 joints' (alternative, Prater type, semimicro size with 7/15 joints').

Bubble counter or flowmeter.-Any convenient arrangement which will measure 10-30 ml /min flow of gas from exit end of second absorption tube.

Preheater furnace.-Electric^{8,7} 12-14 mm LD. by 5 in. long; maintain at temp. of $600 \pm 25^\circ\text{C}$.

Burning furnace.-Electric^{8,7} 13-14 mm LD. by 4 in. long. Furnace should reach a temp. of 600-700°C. in 5 min, about 800°C. in 15 min, with max of 850°C. in 30 min.

Long furnace.-Electric^{6,7} 13-14 mm I.D. by 8 in. long; maintained at a temp. of 775-800°C.

Constant temperature mortar.-Electric⁸ 13-14 mm LD. by 3 in. long, thermostatically controlled to maintain a temp. of $177 \pm 2^\circ\text{C}$.

Boat.-Platinum, micro.

Finger cots.-Chamois.

*Tweezer.*⁸-Platinum tipped.

PREPARATION OF APPARATUS

Preheater.-Place copper oxide in preheater tube, connect spiral cooling coil, immerse coil in beaker of water, and support assembly by suitable clamps and stand. Place electric furnace over preheater tube and maintain at ca 600°C. Connect side arm of combustion unit to needle valve of oxygen pressure regulator by suitable tubing rubber or tygon.

Bubble counter-U-tube.-Fill bubble counter and U-tube by placing glass wool plug at bottom of U, fill side next to bubble counter with Dehydrite to within $\frac{1}{2}$ in. of side arm and cap with another glass wool plug. Place Ascarite layer in other side to within $1\frac{1}{2}$ in. of side arm, then insert a glass wool plug, ca 1 in. of Dehydrite, and finally a second plug. Cement in stoppers with glass cement or paraffin, then with medicine dropper introduce concentrated sulfuric acid into bubbler until level is 3-4 mm above bubbler tip. Connect to preheater with pressure clamp.

Combustion tube.-Clean and dry combustion tube (Fig. 1). Place 10-mm roll of silver in exit end with one or two strands reaching to open end of ground joint. Insert a loose asbestos plug (not choking plug), 40 mm of lead dioxide, asbestos plug, and a second silver roll 25 mm long; which should extend into long furnace about $\frac{1}{2}$ inch. Introduce asbestos plug, 60 mm of copper oxide, asbestos plug, 30-mm platinum gauze roll, asbestos plug, 60-mm copper oxide, asbestos plug, and finally 30-mm platinum gauze, which should extend about 10 mm beyond end of long furnace. Place prepared tube in furnaces with exit end protruding beyond constant-temp. mortar sufficient to permit connecting absorption tubes. Connect side arm to bubble counter-U-tube.

Absorption tube.-Place glass wool plug in end of water absorption tube, fill tube to within $\frac{1}{2}$ in. of other end with Dehydrite or Anhydrone, and cap with second glass

² *Analytical Chemistry*, 21, 1555 (1949).

³ Rubber connectors may be used.

⁴ If Pyrex tubes are used, furnace temperatures should not exceed 725°C.

⁵ 10 or even 12 mm I.D. tubes may be used, but oxygen flow rate must be increased proportionately.

⁶ Gas heaters may be used but specified temperatures should be maintained.

⁷ Temperature of furnaces measured at center of furnace inside empty combustion tube having one end stoppered.

wool plug. If Pregl tubes are used, seal ground-glass joint with enough glass cement to give clear seal and remove any excess on outer surface of tube with cotton dipped in benzene or other solvent. If Prater tubes are used, lubricate lower $\frac{3}{4}$ of inner joint with minimum of light stopcock grease and insert in outer tube. Prepare carbon dioxide absorption tube by placing glass-wool plug in end, and fill tube to about $1\frac{1}{2}$ in. of other end with Ascarite. Insert $\frac{1}{4}$ inch glass-wool plug, add $\frac{3}{8}$ -inch layer of Dehydrite, and cap filling with another glass-wool plug. Complete assembly of absorption tube as directed for water absorption tube. Connect absorption tubes to combustion tube with ground joints (use no lubricant) or with special impregnated rubber tubing.

Attach bubble counter or flowmeter to exit end of carbon dioxide absorption tube. Counter or meter must be calibrated so that flow rate can be set at 15 to 20 ml per min.

DETERMINATION

Conditioning apparatus.-After various parts of apparatus have been prepared and assembled, condition combustion tube for 3-4 hr with long furnace at 775-800°C. and with oxygen flowing thru apparatus at rate of 15-20 ml per min.⁵ At the same time, make two simulated sample burnings, without sample, with burning furnace at 825-850°C. (Temp. must be ca 100°C. lower if Pyrex combustion tubes are used.)

Burn an unweighed 10-15-mg sample to condition combustion and absorption tubes. With absorption tubes connected, adjust needle valve on pressure regulator so that oxygen flow is 15-20 ml per min., and place burning furnace about 3 in. from long furnace. Place platinum boat containing sample in combustion tube ca 2 in. from long furnace. Insert platinum flashback roll (Fig. 1) so that end of gauze is even with face of furnace next to sample, and stopper tube. Turn on burning furnace and allow it to reach temp. of ca 600°C. before starting sample combustion by moving furnace over sample at rate of 1 in. in 6-8 min. Move the burning furnace across sample only once, taking 18-24 min for full travel of furnace. Turn off burning furnace 5 min after it reaches long furnace but continue to sweep oxygen thru tube for an additional 15 min. before disconnecting absorption tubes. Remove absorption tubes and place by balance to equilibrate. Handle tubes only with clean, chamois finger cots. If Prater tubes are used, turn joints i-turn to seal. If rubber connections are used, wipe only tips of tubes with moist, then dry, chamois before placing them by balance. Wait 10 min. if ground joints were used or 15 min if rubber connections were made, then weigh carbon dioxide-absorption tube first and water-absorption tube second. A glass tare with a volume (surface) ca equal to that of absorption tubes should be used when weighing tubes. Record weights of tubes and then reconnect tubes to combustion tube for subsequent analysis.

Proving the apparatus.-Replace boat with one containing 10-15-mg sample of your own standard compound weighed to nearest 0.01 mg. Repeat combustion and weighing procedure described above. Calculate percentage of carbon and hydrogen in standard sample from increase in weight of carbon-dioxide and water-absorption tubes. Repeat analysis until results from two consecutive runs are within 0.30 per cent of theoretical values and means of carbon and hydrogen results are within 0.20 per cent of theoretical value for the standard compound.

When apparatus has met this test, proceed with analysis of sample, using procedure described above. (Humidity conditions of room may make it necessary to correct apparent weight of water by subtracting a blank value.)

⁵ Use 3-4 lb. oxygen pressure head on low pressure side of pressure regulator.

TABLE 1.-Statistical summary of carbon values

COLLABORATOR NO.	NICOTINIC ACID				BENZYL-BG-THIOURBA HYDROCHLORIDE			
	1148		1950		1948		1950	
	n	\bar{x} %C	n	\bar{x} %C	n	\bar{x} %C	n	\bar{x} %C
0	8	58.47	9	58.59	8	47.38	11	47.42
2	4	58.44			8	47.32		
8	8	58.75	2	58.62	3	47.43	3	47.49
10	2	58.75			8	47.72		
12	2	58.99			2	47.72		
13	3	58.99			3	47.68		
17	8	58.64	5	58.49	2	47.44	6	47.48
23	3	58.53	3	58.85	4	47.42	3	47.72
24	6	58.64			6	47.51		
27	3	58.57			3	47.48		
28	3	58.61			3	47.39		
31	2	58.40			3	47.55		
35	8	59.14	4	58.47	5	47.51	4	47.43
37	4	58.70	4	58.68	4	47.42	4	47.44
39	4	58.62	6	58.53	4	47.42	8	47.32
40	4	58.62	3	58.54	4	47.58	3	47.34
41	5	58.92			4	47.66		
44	4	58.73	4	58.75	3	47.14	3	47.28
45	8	58.64	5	58.66	10	47.59	5	47.52
46	6	58.66	3	58.75	3	47.55	2	47.82
49	21	58.73			17	47.55		
50	8	58.67	8	58.72	3	47.53	7	47.69
Mean		58.68		58.64		47.49		47.50
Mean*		58.68		58.64		47.46		47.50
Theoretical value		58.53		58.53		47.40		47.40
t, calculated		0.69		0.69		0.19		0.19

* Values for data obtained by the 10 collaborators who participated in both studies.

Twelve laboratories reported 55 carbon and hydrogen values for sample 1 (nicotinic acid) and 59 values for sample 2 (benzyl-iso-thiourea hydrochloride). Table 1 shows the number of carbon values reported, n , the mean, \bar{X} , and standard deviation, S , for each analyst's data. Similar data for the 1948 results are also included.

This method of presenting the data was chosen instead of the histograms used in previous reports because it summarizes the data in a condensed but complete form. The data so presented make it easy to compare the relative accuracy and precision of the results for each sample by each analyst and by all the analysts. Further, since all the essential data are presented, the work of any succeeding collaborative study can be readily compared.

Although inspection showed generally close agreement between the two sets of data, a statistical comparison was made to test the relative accuracy. The mean of the \bar{X} 's for each year was determined for each sample and Student's t test (5) applied to determine whether or not the two means were significantly different.

$$t = \frac{\bar{x}}{\sqrt{\frac{n_a n_b (n_a + n_b - 2)}{(n_a + n_b) S_x^2}}}$$

(\bar{x} is the difference between the two means, n_a and n_b the number of \bar{X} 's for 1948 and 1950, respectively, and S_x^2 is the pooled sum of squares.)

The t values obtained, 0.69 for carbon on sample 1 and 0.19 for sample 2, show little indication of any actual difference between the means. The greatest difference between the two sets of data is the lower and more uniform standard deviations obtained in 1950. The means of the \bar{X} 's and S 's obtained by the 10 collaborators who participated in both the 1948 and 1950 studies differed only slightly from those for the total data.

Table 2 shows a summary of the hydrogen data obtained in 1948 and 1950, presented in a manner similar to that used for carbon in Table 1. Comparison of the means of the individual \bar{X} values shows that the 1950 values are nearer the theoretical values of 4.09 and 5.47 per cent H for samples 1 and 2, respectively, than those obtained in 1948. The t test was again applied to determine the significance of the difference between the mean values. The t value for sample 1 was 0.99, which indicates a probability of 0.67 (67 chances in 100) that the difference between the 1948 and 1950 means was not due to chance alone. For sample 2, t was 1.62, and the probability 0.88 that the difference between the means was real. In 1948, the average standard deviations for the two samples were 0.095 and 0.119, whereas in 1950, slightly lower values--0.087 and 0.092--were obtained.

When the mean values for the ten analysts who participated both years were compared, the only difference of any significance was between the

TABLE 2.—Statistical summary of hydrogen values

COLLABORATOR NO.	NICOTINIC ACID				BENZYL-ISO-THIOUREA HYDROCHLORIDE				
	1948		1950		1948		1950		
	n	\bar{x} % H	s	S	n	\bar{x} % H	s	S	
0	8	4.10	0.152	9	4.10	0.052	8	5.44	0.161
2	4	4.21	.098	2	4.07	.022	3	5.57	.107
8	8	4.68	.123				8	5.90	.140
10	2	4.10	.010				2	5.48	.036
12	3	3.98	.052				3	5.35	.173
13									
17	8	4.27	.089	5	4.01	.158	2	5.69	.240
23	3	3.97	.110	3	4.05	.091	4	5.41	.180
24	6	4.16	.078				6	5.56	.045
27	3	4.09	.062				3	5.44	.041
28	3	4.04	.121				3	5.46	.160
31	2	4.06	.099				3	5.37	.156
35	8	4.22	.143	4	4.20	.062	5	5.51	.136
37	4	3.95	.090	4	4.09	.050	4	5.41	.042
39	4	4.09	.085	6	4.17	.056	4	5.35	.096
40	4	4.09	.085	3	4.08	.056	4	5.48	.107
41	5	4.37	.099				4	5.77	.085
44	4	4.20	.052	4	4.02	.101	3	5.53	.052
45	8	4.17	.065	5	4.23	.035	10	5.56	.092
46	6	4.32	.075	3	4.17	.274	3	5.68	.115
49	21	4.12	.186				17	5.42	.205
50	8	4.11	.111	8	4.17	.090	3	5.61	.048
Mean*		4.16	.095		4.11	.087		5.53	.119
Mean*		4.14	.097		4.12	.098		5.53	.123
Theoretical value t, calculated		4.09		0.99	4.09			5.47	
									1.62

* Values for data obtained by 10 collaborators who participated in both studies.

TABLE 3.—*Statistical comparison of carbon and hydrogen ValU68*

YEAR	NICOTINIC ACID				BENZYL-ISOTHIOURBA HYDROCHLORIDE			
	CARBON		HYDROGEN		CARBON		HYDROGEN	
	n	\bar{X} %C	n	\bar{X} %H	n	\bar{X} %C	n	\bar{X} %H
1948	101	58.66	101	4.18	92	47.51	92	5.53
1950	55	58.63	55	4.12	59	47.48	59	5.46
$2S^2_{\bar{X}}$		0.057		0.052		0.059		0.054
$\bar{X}(1948) - \bar{X}(1950)$		0.03		0.06		0.03		0.07
F, calculated		2.59		3.27		1.12		2.31
F, critical (98%)		1.78		1.78		1.75		1.75
Theoretical value		58.53		4.09		47.40		5.47

mean of the \bar{X}'_s for sample 2. The t value for these two sets of data was 1.58, and the probability of the difference being real was 0.88.

A second type of comparison was made in which the total data for each element for each compound were considered as a representative population sample. Table 3 shows the mean and standard deviation for each set of data for 1948 and 1950.

The relative accuracy of the 1948 and 1950 data was determined (1) by calculating the standard deviation of the difference between means.

$$S_{\bar{x}} = \sqrt{\frac{S_a^2}{n_a} + \frac{S_b^2}{n_b}}$$

and comparing 2 times this value ($2S_{\bar{x}}$) with the numerical difference between means ($X_a - X_b$). If the latter value was the greater, as was true for hydrogen for both samples, the difference between means was significant at the 95 per cent level.

Snedecor's F test (6) was used to compare the precisions obtained in the two studies. In three of the four cases, the precision obtained in 1950 was significantly better at the 98 per cent level than that in 1948; only for carbon in sample 2 was there no definite improvement in precision.

Even though the analysts were unfamiliar with the new method, the results obtained were superior to or as good as those obtained when each analyst used his own, with which he was completely familiar. This indicated that the method has excellent possibilities of being suitable for adoption by the A.O.A.C. The Referees therefore recommend that the 1950 test method for carbon and hydrogen be adopted, first action, and that further work be done to prove the method through the analysis of a greater variety of materials and to look for possible improvements in the procedure.

MICROKJELDAHL DETERMINATION OF NITROGEN

The 1949 collaborative studies on determination of nitrogen by the Kjeldahl procedure resulted in the adoption as first action of the method employed in those studies. In keeping with the recommendation that further studies be made both on the regular method and on a method for determining N-O and N-N bonded nitrogen, investigation of the method was continued this year.

A. *Effect of Potassium Sulfate Concentration.*-It had been suggested that better results would be obtained by changing the high potassium sulfate concentration of the digestion mixture from the recommended 1.30 g per 2 ml of sulfuric acid to a lower value. Consequently, the 1950 collaborators were asked to analyze a sample of the same nicotinic acid used in the 1949 studies by the same method (9), with the one exception that only 0.85 g of potassium sulfate be used per 2 ml of sulfuric acid.

Table 4 shows the 77 results obtained by the 14 analysts reporting. The number of determinations, n , the mean, \bar{X} , and the standard deviation, S , are given for each analyst. For ease of comparison, the same data for each collaborator participating in 1949 are presented. Although inspection of the data shows conclusively that better results were obtained with the

TABLE 4.—*Statistical summary of Kjeldahl nitrogen values for nicotinic acid*

COLLABORATOR NO.	1949			1950		
	(1.20 g K_2SO_4)			(0.85 g K_2SO_4)		
	n	\bar{X} (%N)	S	n	\bar{X} (%N)	S
0	13	11.37	0.043	4	11.14	0.085
6				2	11.02	.106
9	8	11.35	.045	8	11.33	.059
15	5	11.60	.190	6	10.48	1.01
19				9	6.32	2.00
21				8	11.24	.076
22	2	11.34	.056	2	11.31	.028
23	3	11.35	.280	3	6.14	1.30
24	3	11.30	.020			
25	3	11.33	.125			
29	3	11.34	.044	3	11.33	.030
30	8	11.44	.073	8	11.39	.124
36	3	11.31	.010			
37	8	11.20	.167	2	8.44	2.23
49	5	11.23	.187			
51	9	11.15	.303	8	11.42	.125
57	3	11.41	.050	8	11.24	.092
59				6	11.03	.103
Mean		11.34	.114		10.27	.526
Mean*		11.36	.125		10.42	.508
Theoretical value		11.38			11.38	
t , calculated			2.13			
t , calculated			1.60			

* Values for data obtained by the 10 collaborators who participated in both studies.

larger amount of potassium sulfate, a statistical comparison was made. As with carbon and hydrogen, Student's t test (5) was used to test the significance of the difference between means. Two separate comparisons were made, one utilizing all the data for both years, and the other with only the data obtained from those collaborators who participated in both studies. The t value obtained for the first comparison was 2.13, with a resulting probability of 0.96 that the difference was not due to chance; for the second comparison, the t value was 1.60, with a probability of 0.87.

The values reported in 1950 were considered as a single population sample and compared with those for 1949. Table 5 shows the results. Critical differences in precision (F value), and accuracy (difference between means) were obtained, the 1949 values being better in both instances. In both types of statistical comparison, therefore, there was strong evidence that the method employing 1.30 g of potassium sulfate gave results superior to those obtained with 0.85 g.

TABLE 5.—*Statistical comparison of nitrogen values*

YEAR	NICOTINIC ACID		
	n	\bar{X} (% N)	S
1949	76	11.17	0.59
1950	78	10.35	1.95
$2 S_p$		0.46	
$\bar{X}(1949) - \bar{X}(1950)$		0.82	
F, calculated			10.94
F, critical (98%)			1.71
Theoretical value		11.38	

The means of results obtained by 7 of the 14 analysts who reported in 1950 were within 0.20 per cent of the theoretical value (11.38 per cent), whereas the remaining 7 means were all low by 3 per cent or more. The reason that half the analysts in 1950 failed to obtain satisfactory results while the other half were successful is apparently tied up with the difference in the amount of heat applied to the digestion flasks. Variation in the amount of heat were expected because even similar digestion racks will produce different amounts of heat, depending upon the B.T.U. of the gas or the voltage applied. The temperature of the boiling digestion mixtures was presumably the same in all cases, since each analyst used the same digestion mixture and was instructed to "digest 4 hours at vigorous boil with the acid condensing well up into the neck of the flask." These directions did not specify the amount of heat to be applied because there was no satisfactory way of stating or measuring this. Consequently, the amount of superheating that took place at the glass-liquid interface varied according to the amount of heat applied and is believed to be the cause of the variation in the results obtained. Data published previously (2) have indicated this to be the case. Refractory materials, such as nicotinic acid, fortunately can be quantitatively decomposed if a higher concentration of potassium sulfate (1.3 g per 2 ml sulfuric acid) is used. This eliminates the necessity for extensive superheating, an amount not possible with some digestion rack heaters.

B. *Analyses of Compounds Containing N—O Linkages.*—The failure of the Friedrich-hydriodic acid method for determining N—O and N—N bonded nitrogen to stand up under collaborative test in 1949 led to a search for another method for reducing N—O groups prior to Kjeldahl digestion. The sodium hyposulfite, Na₂S₂O₄ (also called sodium hydrosulfite) reduction method of Shaefer and Becker (4) had been slightly modified and used successfully in the Referee's laboratory to analyze compounds not reduced by the salicylic acid or by the carbon methods. As a result, it was decided to test the use of Na₂S₂O₄ collaboratively this year. The following directions and two samples, nicotine picrate and p-nitrochlorobenzene, were sent to each collaborator.

Dissolve 10- to 30-mg sample in 3 ml of water, ethanol, or acetone in a 30-ml Kjeldahl flask. Heat if necessary, but cool solution before continuing. Add 0.4 g of sodium hyposulfite (Na₂SO₃), 3 ml of water, and boil gently for 5 minutes. Cool, add 1 ml of 50 per cent H₂SO₄, place on digestion rack and boil until volume of solution is reduced to approximately 2 ml. Cool, add 1.0 g K₂SO₄, 40 mg HgO, and 1.5 ml H₂SO₄, and continue analysis as directed in the regular microkjeldahl procedure, "First action," beginning with "and digest 4 hours . . ."

Table 6 shows the results obtained for the two samples containing nitro groups. The mean of the means obtained by the different analysts was 17.18 per cent nitrogen for nicotine picrate (theoretical for N, 18.06 per cent). Application of the *t* test (7) gave a value of 1.87, with a proba-

TABLE 6.—Statistical summary of nitrogen values by hyposulfite reduction method

COLLABORATOR NO.	NICOTINE PICRATE			p-NITROCHLOROBENZENE		
	"	\bar{X} %N	s	"	\bar{X} %N	s
0	9	18.07	0.067	10	8.88	0.037
6	2	17.92	.028	2	8.59	.022
9	8	17.78	.330	7	5.40	.888
15	6	17.99	.099	3	8.87	.036
19	8	17.52	.189	8	8.14	.274
21	4	17.33	.182	8	7.81	.313
22	2	17.95	.014	2	8.81	.071
23	3	18.13	.257	3	2.52	.472
29	3	13.22	.218	3	6.12	1.24
30	9	18.09	.078	7	8.81	.107
37	4	17.93	.126	6	6.94	1.67
51	8	17.84	.098	8	7.29	1.20
57	3	17.83	.110	3	8.76	.010
59	6	12.90	.603	-	-	-
Mean		17.18	.171		7.46	.488
Theoretical value		18.06			8.89	
<i>t</i> , calculated		1.87			2.76	

bility of 0.91 that the difference between the mean and theoretical values was not due to chance. This apparently low t value was due to the exceptionally high standard error of the determination. Inspection of the mean values of the 14 analysts showed that two means (collab. No. 29 and 59) were much lower than the others. When these two values were discarded, the mean became 17.87 per cent—only 0.19 per cent—low, but the t value was 2.79 and the probability 0.98 that there was an inherent error in the method.

The mean of the means for p-nitroWorobenzene was 7.46 per cent N, as compared with the theoretical for N of 8.89 per cent. The t value of 2.76 again indicates a probability of 0.98 that the deviation from theory was not due to chance.

The fact that twelve analysts obtained values with a mean of 17.87 per cent N gives promise that, by further study, the method can be made satisfactory for some nitro compounds. The choice of p-nitrochlorobenzene was in a sense unfortunate, because in some cases the low results were apparently due to distillation of the sample from solution during reduction. This demonstrated, however, one of the faults of the method. Another and more important objection is that the sample must be soluble in water, alcohol, or acetone.

Since this study was begun, work has been reported by Secor *et al.* (3) on the analyses of N-O and N-N groups by the Friedrich's method. Their data show that the larger amount of potassium sulfate used (1.30 g per 2 ml acid) was a probable source of error in the 1949 study of this method. Therefore, a further collaborative study of a revised method should be made.

RECOMMENDATIONS

As a result of the data obtained in this year's study, it is recommended that the microkjeldaw method, first action, remain as adopted (1.30 g potassium sulfate per 2 ml sulfuric acid) and that the method be further proved by collaborative analyses of a greater variety of nitrogenous compounds. Also, it is recommended that work on the sodium hyposulfite ($\text{Na}_2\text{S}_2\text{O}_4$) method for reduction of nitro groups be suspended until a further study of the Friedrich's hydriodic acid reduction method has been made.

The appointment of an Associate Referee on methods for micro group analysis is recommended, and also that work be conducted on methods for the halogens, sulfur, and phosphorus.

LITERATURE CITED

- (1) HOEL, PAUL G., "Introduction to Mathematical Statistics," p. 71, New York, John Wiley & Sons, Inc. (1947).
- (2) OGG, C. L., and WILLITS, C. O., *This Journal*, 33, 100 (1950).

* For report of Subcommittee C and action of the Association, see *This Journal*, 34, 50 (1951).

- (3) SEOR, GERALDINE E., LONG, MARION C., DUGAN, MARY T., and WHITE, LAWRENCE M., *Ibid.*, 33, 872 (1950).
- (4) SHAEFER, W. E., and BEOKER, W. W., *Anal. Chem.*, 19,307 (1947).
- (5) SNEDEOOR, G. W., "Statistical Methods," 4th Ed., p. 82, Ames, Iowa, Iowa State College Press (1946).
- (6) — — —, *Ibid.*, p. 218.
- (7) — — —, *Ibid.*, p. 42.
- (8) WILLITS, C. O., and OGG, C. L., *This Journal*, 32, 561 (1949).
- (9) — — —, *Ibid.*, 33, 179 (1950).

REPORT ON FERTILIZERS

By F. W. QUACKENBUSH (Purdue University, Agricultural Experiment Station, Lafayette, Indiana), *Referee*

No reports were made for the following subjects: Acid- and Base-forming Quality; Boron; Copper and Zinc; Inert Materials; Magnesium and Manganese.

RECOMMENDATIONS

The recommendations made by the Associate Referees are approved, for Nitrogen, Phosphoric Acid, Potash, Sampling, Sulfur, and Free Water, respectively.

REPORT ON SAMPLING FERTILIZERSt

By H. R. ALLEN (Kentucky Agricultural Experiment Station, Lexington, Kentucky), *Associate Referee*

This paper gives the results of a collaborative study on preparation of sample for analysis.

Approximately one-half pound (227 grams) of unground fertilizer was sent to control officials in 42 States and Canada. Each was asked to grind this portion as the routine samples are ground and to return the entire portion to the Associate Referee. Information was requested about the type of grinder used and the amount of sample usually prepared for the laboratory.

The collaborative sample was a mixed fertilizer of approximately 4-12-8 grade which contained about 25 per cent of organic materials consisting of castor meal, process tankage, ground peanut hulls, and ground tobacco stems. In this sample 21 per cent of the materials were coarser than 2 mID in particle size, 30 per cent was between 2 mm and 1 mm, 28 per cent was between 1 mID and 0.5 mID, and 21 per cent was finer than 0.5 mm. This sample contained 4.8 per cent moisture.

* For report of Subcommittee A and action of the Association, see *This Journal*, 34,41 (1941).

† This investigation, made in connection with a project of the Kentucky Agricultural Experiment Station, is published by permission of the Director.

TABLE 1.-*Results of sieving test on portions of a mixed fertilizer ground in State Control laboratories*

CONTROL LAB. NO.	MILL USED	PER CENT OF SAMPLE PASSING SIEVE WITH OPENINGS OF—		
		1.0mm	0.5mm	60 MESH
1	Mikro-samplmill	99.8	91	81
6	Mikro samplmill	99.8	94	70
8	Mikro samplmill	100.0	96	90
10	Mikro-samplmill	100.0	96	85
11	Mikro-samplmill	98.7	92	74
12	Mikro-samplmill	99.8	96	83
14	Mikro-samplmill	100.0	98	92
19	Mikro-samplmill	91.0	72	54
20	Mikro-samplmill	100.0	98	90
21	Mikro-samplmill	100.0	96	90
22	Mikro-samplmill	98.8	96	88
24	Mikro-samplmill	98.0	92	82
25	Mikro-samplmill	99.8	96	85
30	Mikro-samplmill	100.0	96	88
31	Mikro-samplmill	99.8	96	88
33	Mikro-samplmill	99.8	96	86
35	Mikro-samplmill	95.0	81	65
16	Mortar and pestle	94.0	75	51
17	Mortar and pestle	86.0	52	33
26	Mortar and pestle	83.0	52	32
27	Mortar and pestle	99.0	74	51
36	Mortar and pestle	87.0	61	37
13	Hammermill	98.0	89	72
18-	Hammermill	87.0	57	36
34	Hammermill	99.5	88	68
39	Hammermill	100.0	95	83
2 ^b	Sturdevant	97.0	58	36
3	Sturdevant	100.0	99	91
9	Sturdevant	100.0	99	81
4 ^c	Burr Mill	100.0	99	95
23 ^c	Burr Mill	95.0	60	38
29	Burr Mill	99.3	95	86
5 ^d	Braun Mill	99.3	91	60
38	Braun Mill	97.0	93	81
7	Lab. Pulverizing	99.8	87	66
15	Abbe Ball Mill	98.0	96	94
28	Bird Impact Mill	99.8	96	94
32	Bucking Board	99.8	94	63
37	Wiley Mill	90.0	55	35

^a Wiley and Quaker mills also listed.

^b Trace held on 10 mesh sieve.

^c Mill made by Enterprise Manufacturing Company.

^d Package broken and some of sample lost in transit.

Replies were received from 39 officials. Results of sieving tests made in this laboratory on the ground portions submitted by the collaborators are given in Table 1. Screens having a diameter of 8 inches were used in the sieving tests.

DISCUSSION OF RESULTS

The collaborative sample was purposely made to contain a somewhat larger amount of organic materials than is usually found in mixed fertilizer. Results in Table 1 show that, of the 39 ground portions from collaborators, the whole portion was ground finer than 1 mm in particle size in only 10 instances. In 13 other portions, more than 99 per cent of the material passed a 1 mm sieve.

The Mikro-samplmill was used in 17 laboratories. In 6 of the portions from these laboratories all the material was ground to pass a 1 mm sieve, and in 6 other portions 99 per cent or more of the materials passed this sieve.

In a number of instances there were both satisfactory and unsatisfactory grindings reported for the same type of grinder. This may indicate that technique and attention to detail are as important as the mill or grinder used.

Many of the mills have sieves fitted into the grinding chamber and usually the sample is not sieved again after grinding. Since some of these sieves have openings larger than the particle size of sample desired, fineness of the ground sample should be checked occasionally by re-sieving through a sieve of the correct mesh.

Size of sample prepared for the laboratory.-The collaborators were asked to state size of sample usually prepared for the laboratory. This meant size of sample actually ground. Less than 100 grams of sample were prepared in 5 cases, 100 grams were prepared in 12 cases, one-half pound was ground in 10 cases, and one pound or more was ground in 11 cases. The Associate Referee believes that at least one-half pound of sample should be prepared for analysis.

USE OF MIKRO-SAMPLMILL

This laboratory has used the Mikro-samplmill for some time. It is satisfactory if the sample does not contain excessive moisture and if certain parts of the mill are replaced when they become worn. Two factors which affect the use of this mill will be mentioned.

1. *Wear.*-The rotor blades wear off with use, and when they are worn some unground sample is left on the screen, particularly if considerable organic material is present. Wear of the stainless steel liner results in the same condition. Both rotor and liner should be replaced when wear is noted.

2. *Size of screen used.*-A screen is attached in the bottom of the

grinding chamber of this mill. Screens with various diameters of openings are available. In this type of mill, screen openings can be considerably larger than the particle size of sample desired. The smaller screen openings, such as .039 inch, are not practical unless the sample is very dry and only a small amount is ground. The more moisture in the sample the larger is the screen opening required. In this laboratory a screen with round openings 1/16 inch in diameter is used for routine sample preparation. Table 2 shows variation of particle size of sample prepared under some of the conditions discussed here.

SUMMARY

Unground portions of a mixed fertilizer were submitted to state control officials for grinding as in preparation of sample for analysis.

Sieving tests made on the ground portions show considerable variation

TABLE 2.-*Effect of worn rotor and of different size screen openings on particle size of ground sample**

	PER CENT OF SAMPLE PASSING SIEVE WITH OPENINGS OF—		
	1mm	0.5mm	60 MESH
Worn rotor 1/16 in. diam. openings	98.2	91	79
New rotor 1/16 in. diam. openings	99.6	95	87
New rotor 3/64 in. diam. openings	100.0	98	90

* 227 grs of the collaborative sample ground in the Mikro-S&mp1mill.

in fineness. In 16 of the 39 ground portions, more than 1 per cent of the materials were coarser than 1 mm in particle size. These results indicate that more care should be taken in preparation of sample for analysis.

Some precautions necessary in use of Mikro-samplmill are discussed.

RECOMMENDATIONS*

It is recommended-

(1) That work on sampling and preparation of sample for analysis be continued.

* For report of Subcommittee A and action of the Association, see *This Journal*, **34**, 41 (1951).

REPORT ON PHOSPHORIC ACID

RELATION OF PARTICLE SIZE OF CALCIUM METAPHOSPHATE
TO ITS CITRATE SOLUBILITY AND FERTILIZER EFFICIENCY

By K. D. JACOB, *Associate Referee*, W. H. ARMIGER, J. H. CARO, and W. M. HOFFMAN (Division of Fertilizer and Agricultural Lime, Bureau of Plant Industry, Soils, and Agricultural Engineering, Agricultural Research Administration, U. S. Department of Agriculture, Beltsville, Maryland)

Investigations of production of calcium metaphosphate glass by high-temperature reaction of phosphorus pentoxide with phosphate rock were initiated in 1935 by the Tennessee Valley Authority, Wilson Dam, Alabama, the only manufacturer of this material thus far, and have now been extended to large-scale operation (5, 6, 7). Formerly, the production was used entirely in experimental work and in test demonstrations of its merits as a fertilizer. Recent improvement and expansion of the manufacturing facilities has resulted, however, in greater output of metaphosphate than is required for such purposes, and the surplus is now being marketed as a -10 mesh material containing 3 to 5 per cent of ground limestone as a conditioning agent.

The marketed product, of which a typical mechanical analysis is given in Table 3, contains about 15 per cent by weight of particles coarser than 20 mesh, 50 per cent coarser than 35 mesh, and 20 per cent finer than 100 mesh. The problem of the laboratory evaluation of the quality of the phosphoric acid in such a coarsely ground material involves the important question of the relation of the particle size of the product to its solubility in neutral ammonium citrate solution and to its fertilizer efficiency.

Under the conditions of the official method for available phosphoric acid the citrate solubility of calcium metaphosphate, like that of defluorinated phosphate rock (alpha phosphate), basic slag, phosphate rock-magnesium silicate glass, and similar types of phosphate fertilizers, is known to depend, within certain limits, on the particle size of the material (9, 10, 13, 14, 15, 16, 23). Hill (9) has shown that with unfractionated grinds of metaphosphate and with intermittent agitation during the citrate digestion the effect of particle size on the solubility of the phosphoric acid practically disappears at a fineness of - 60 mesh. Similar results have been reported from the laboratory of the Tennessee Valley Authority, and it has been shown that the solubility of the phosphoric acid progressively decreases as the maximum particle size of unfractionated grinds and of closely sized fractions is increased beyond 60 mesh (24).

Numerous pot and field tests have indicated that certain unfractionated

grinds of metaphosphate, in which the maximum particle size and the distribution of particle size over the fineness range have varied rather widely, are excellent sources of phosphoric acid for many crops under humid conditions (2,4,8, 12, 19, 20, 21, 23, 25). No experiments seem to have been made, however, with closely sized particles of metaphosphate.

Since the available information did not permit a decision as to whether the citrate solubility and fertilizer efficiency of calcium metaphosphate are related to its fineness over wide ranges of closely sized particles, a series of laboratory and greenhouse experiments was carried out under carefully controlled conditions to obtain data which might enable this question to be resolved.

PARTICLE SIZE-SURFACE AREA RELATIONS

Hill (9) points out that furnace-made phosphates, unlike pulverulent materials such as superphosphate, often consist of nonporous particles whose surface area is restricted to the outside of the discrete particles, and that the phosphoric acid solubility is likely to be quite sensitive to the fineness of the sample. As calcium metaphosphate glass would seem to be an excellent example of a product consisting of nonporous particles, it is of interest to note the relation of the particle size of this material to its theoretical surface area. This relation is given in Table 1, which shows the geometrical surface areas of cubes or spheres of metaphosphate over a wide range of mesh sizes.

TABLE 1.-Relation of mesh size to apparent surface area of calcium metaphosphate

U. B. NO.	SIEVE		SURFACE* OF CUBES OR SPHERES	
	MESHES PER LINEAR INCH	OPENING, MICRONS	CM ² PER CM ³	CM ² PER GRAM
12	10	1,680	35.7	14.3
20	20	840	71.4	28.6
40	35	420	143	57.2
60	60	250	240	96.0
70	65	210	286	114
80	80	177	339	136
100	100	149	403	161
140	150	105	572	229
200	200	74	811	325
270	270	53	1,132	453
325	325	44	1,364	546
-	-	20	3,000	1,200

* Exclusive of pore space; estimated density 2.5.

MATERIALS

Calcium Metaphosphate.-The sample of calcium metaphosphate (No. 2741, TVA No. 64,665) was supplied by the Division of Chemical En-

TABLE 2.-Formulae of experimental mixed fertilizers containing calcium metaphosphate

SAMPLE NO.	MANUFACTURER	GRADE	FORMULA, POUNDS PER SHORT TON											
			(NH ₄) ₂ SO ₄	NITROGEN SOLUTION	METAPHOSPHATE	SUPERPHOSPHATE	KCl	CaCl ₂	DOLOMITE	ORGANIC MATERIAL	INERT FILLER			
2829	A	0-16-16	-	-	125	1,212.5	622.5	40	-	-	-	-	-	-
2833	B	4-16-8	100	125	130	1,200	270	-	-	-	-	-	-	175
2830	A	0-20-10	-	-	172.5	1,467.5	320	40	-	-	-	-	-	-
2831	B	0-20-10	-	-	300	1,100	325	-	75	-	-	-	-	200
2834	C	0-20-20	-	-	645	-	656	-	599	-	100	-	-	-
2832	B	0-20-20	-	-	665	-	665	-	-	-	-	-	-	670

• Kennidol.

gineering, Tennessee Valley Authority, Wilson Dam, Alabama. Analysis by the TVA laboratory showed 26.6 per cent CaO and 63.6 per cent total P_2O_5 . A slightly lower value for total P_2O_5 (63.34 per cent) was obtained by the writers. The chemical composition and the particle-size distribution of the material as received were stated to be typical of the product planned for distribution by the Authority in 1950. It contained about 3 per cent of ground limestone as a conditioning agent.

Mixed Fertilizers.-*Samples* of six experimental formulas of mixed fertilizers containing different quantities of TVA calcium metaphosphate were supplied by three fertilizer manufacturing cooperatives: Wisconsin Cooperative Farm Plant Foods, Green Bay, Wisconsin; Farm Bureau Services, Inc., Saginaw, Michigan; and Minnesota Farm Bureau Service Co., St. Paul, Minnesota. The formulas of the mixtures are given in Table 2.

PREPARATION OF SAMPLES

Three series of samples of the calcium metaphosphate were prepared for study of the effect of particle size on the values obtained for citrate-insoluble phosphoric acid.

TABLE 3.-*Mechanical composition of calcium metaphosphate ground to different finenesses*

FINENESS ^a	COMPOSITION, MESH							
	-10. +20	-20. +35	-35. +60	-60. +80	-80. +100	-100. +160	-110. +200	-200
mesh	per cent	per cent	per cent	per cent	per cent	per cent	per cent	per cent
-10b	16.4	33.3	17.2	7.4	5.2	5.8	4.2	10.4
-20	-	39.3	20.3	10.9	5.6	6.5	4.9	12.5
-35	-	-	18.6	14.7	9.5	13.5	11.1	32.6
-60	-	-	-	14.0	17.4	20.7	13.8	34.1
-80	-	-	-	-	14.8	26.0	17.1	42.1
-100	-	-	-	-	-	22.7	22.5	54.8
-150	-	-	-	-	-	-	15.3	84.7

^a Screen openings in the sieve series are given in Table 1.

^b Original sample as received; contained 0.1% of +10-mesh material.

For the first series, separate portions of the original sample of metaphosphate were ground to pass wire sieves ranging from 20 to 150 square meshes per linear inch. In each case the material coarser than the specified mesh was removed by screening, carefully ground in a horizontal-plate mill to pass the sieve, and then thoroughly mixed with the previously separated portion. The particle-size distribution in the prepared samples is given in Table 3.

The second series of samples comprised several particle-size fractions of calcium metaphosphate separated with the aid of appropriate sieves,

directly from the original material as received. The percentages of total phosphoric acid in the fractions were as follows:

	TOTAL P ₂ O ₅ ^b
mesh	per cent
-10, + 20	65.00
-20, + 35	64.68
-35, + 60	64.94
-60, + 80	64.35
-80, +150	64.07
-150	57.62

^a Screen openings in the sieve series are given in Table 1.
^b The original sample contained 63.34% total p.o.*.

For the third series of samples, separate portions of the original calcium metaphosphate and of the mixed fertilizers were ground in a high-speed (8,200 r.p.m.) hammer mill of the type now widely used in fertilizer laboratories, with the aid of mill screens having circular openings 0.125, 0.0625, and 0.039 inch in diameter, respectively. The distribution of particle size in the prepared samples was governed solely by the opening in the mill screen and the grinding characteristics of the material. Excluding mixed fertilizer No. 2831, which caked considerably after grinding, the mechanical composition of the samples prepared in this manner is given in Table 4.

TABLE 4.-Mechanical composition of calcium metaphosphate materials ground in a laboratory hammer mill

SAMPLE NO.	MATERIAL	GRADE	METAPHOS- PHATE CONTENT	DIAMETER OF OPEN- INGS IN MILL SCREEN	COMPOSITION, MESH ^a		
					+35	-35, +60	-60
			lb./short ton	inch	per cent	per cent	per cent
2829	Mixed fertilizer	0-16-16	125	0.125	2.6	8.7	88.7
2833	Mixed fertilizer	4-16-8	130	0.125	5.0 ^b	16.0	79.0
2830	Mixed fertilizer	0-20-10	172.5	0.125	4.8	13.2	82.0
				0.039	0.4	5.0	94.6
2834	Mixed fertilizer	0-20-20	645	0.125	5.4	11.8	82.8
2832	Mixed fertilizer	0-20-20	665	0.125	9.4 ^c	14.9	75.7
				0.039	0.3	6.5	93.2
2741	Calcium metaphosphate	-	2,000	0.125	10.5 ^d	20.6	68.9
				0.0625	3.9	16.0	SO.1
				0.039	0.7	11.1	88.2

^a Screen openings in the sieve series are given in Table 1.

^b Contained 0.4% of +20-mesh material.

^c Contained 0.9% of +20-mesh material.

^d Contained 0.5% of +20-mesh material.

METHODS OF ANALYSIS

Chemical Analysis.—Analyses for citrate-insoluble phosphoric acid were made in accordance with the official method (*Methods of Analysis*, 1945, p. 24, sec. 2.16) with agitation during the citrate digestion by (a) manual shaking at 5-minute intervals and (b) continuous end-over-end agitation at 22 r.p.m. in the MacIntire-Marshall-Meyer apparatus (18), respectively. Since slightly lower values for citrate-insoluble phosphoric acid were usually obtained when the sample was washed with water before the citrate digestion, as prescribed in the official method for water-soluble phosphoric acid, this procedure was followed in all the analyses.

For determination of phosphoric acid in the metaphosphate and its citrate-insoluble residues, the sample was digested with 30 ml. of nitric acid and 10 ml. of hydrochloric acid for a period sufficient to insure solution of the phosphate and its hydrolysis to the ortho form.

Mechanical Analysis.—A sample of 10 grams was used and the sieves were shaken for 1 hour on a Ro-Tap machine.

RESULTS OF ANALYSES

The effects of particle size, sample weight, and type of agitation during the citrate digestion on the values obtained for citrate-insoluble phosphoric acid in calcium metaphosphate are shown in Table 5. With continuous agitation during the citrate digestion the particle-size effect virtually disappeared when the metaphosphate was ground to pass a 35-mesh sieve, regardless of the weight of sample taken for analysis. Likewise, virtually constant values for citrate-insoluble phosphoric acid were obtained on the -35, +60 mesh and finer fractions of material separated from the original metaphosphate. With intermittent agitation, however, a higher degree of fineness was required to eliminate the particle-size effect, namely, -60 mesh for the gross grind and -80, +150 mesh for the mechanical fractions. As might be expected, the agreement among the replicate determinations on the coarser samples was generally poor. No important differences among the values for citrate-insoluble phosphoric acid in the particle-size fractions were found when the analyses were made on - 80 mesh grinds.

It will be noted that for a given degree of sample fineness and type of agitation during the citrate digestion, the weight of metaphosphate taken for analysis—at least within the limits of 0.25 to 1.00 gram—generally had relatively little effect on the values obtained for citrate-insoluble phosphoric acid (Table 5).

Table 6 shows the average results obtained by three laboratories—the Bureau of Plant Industry, Soils, and Agricultural Engineering (BPI), the Tennessee Valley Authority (TVA), and the University of Tennessee Agricultural Experiment Station (UT)—for citrate-insoluble phosphoric acid in 1-gram samples of portions of the calcium metaphosphate (No.

TABLE 5.—*Effect of particle size, sample weight, and type of agitation during citrate digestion on results for citrate-insoluble P₂O₅ in calcium metaphosphate*

FINENESS ^a	CITRATE-INSOLUBLE P ₂ O ₅ BY—					
	INTERMITTENT AGITATION			CONTINUOUS AGITATION		
	WEIGHT OF SAMPLE			WEIGHT OF SAMPLE		
	0.25 GRAM	0.50 GRAM	1.00 GRAM	0.25 GRAM	0.50 GRAM	1.00 GRAM
mesh	per cent	per cent	per cent	per cent	per cent	per cent
Original sample ground to different degrees of fineness ^b						
-10 ^c	10.14	11.83	12.90	3.44	5.54	6.59
	8.72	10.74	11.63	4.58	4.48	7.25
	10.94	10.72	12.46	3.76	4.72	8.06
	9.93	11.10	12.33	3.93	4.91	7.30
- 20	—	10.13	9.49	2.20	1.96	4.07
	5.62	9.47	10.53	2.26	2.39	3.49
	5.95	10.16	10.95	2.16	2.26	3.65
	5.79	9.92	10.32	2.21	2.20	3.74
- 35	1.20	1.45	1.99	0.74	0.87	0.86
	1.25	1.40	1.90	0.86	0.94	0.87
	1.18	1.31	2.00	0.78	0.78	0.85
	1.21	1.39	1.96	0.79	0.86	0.86
- 60	0.77	0.78	0.87	0.86	0.76	0.85
	0.80	0.76	0.89	0.70	0.68	0.74
	0.74	0.75	0.88	0.72	0.70	0.75
	0.77	0.76	0.88	0.76	0.71	0.78
- 80	0.78	0.80	0.85	0.74	0.79	0.70
	0.79	0.71	0.80	0.77	0.76	0.75
	0.75	0.76	0.79	0.70	0.78	0.79
	0.77	0.76	0.81	0.74	0.78	0.75
-150	0.63	0.59	0.69	0.75	0.81	0.74
	0.68	0.68	0.73	0.74	0.72	0.76
	0.69	0.75	0.76	0.77	0.77	0.74
	0.67	0.67	0.73	0.75	0.77	0.75

TABLE 5—(Continued)

FINENESS ^a	CITRATE-INSOLUBLE P ₂ O ₅ BY—					
	INTERMITTENT AGITATION			CONTINUOUS AGITATION		
	WEIGHT OF SAMPLE			WEIGHT OF SAMPLE		
	0.25 GRAM	0.50 GRAM	1.00 GRAM	0.25 GRAM	0.50 GRAM	1.00 GRAM
mesh	per cent	per cent	per cent	per cent	per cent	per cent
Particle-size fractions of original sample ^d						
-10, + 20	30.90	33.88	34.85	14.94	14.71	16.13
	30.88	33.84	34.41	13.66	15.91	16.55
	30.68	32.86	33.10	14.74	15.82	16.81
	30.82	33.53	34.12	14.45	15.48	16.50
-20, + 35	17.92	18.15	21.56	3.04	3.20	6.10
	15.73	16.67	24.87	3.56	4.40	6.20
	20.65	19.83	21.63	4.12	5.24	6.08
	18.10	18.22	22.69	3.57	4.28	6.13
-35, + 60	2.80	3.67	4.64	0.74	0.71	0.81
	2.91	4.11	5.76	0.76	0.85	0.83
	3.40	3.89	5.65	0.82	0.73	0.80
	3.04	3.89	5.35	0.77	0.76	0.81
-60, + 80	1.04	1.16	1.34	0.72	0.78	0.80
	0.90	1.06	1.31	0.81	0.84	0.80
	1.05	1.03	1.43	0.73	0.77	0.79
	1.00	1.08	1.36	0.75	0.80	0.80
-80, +150	0.47	1.31	—	0.79	0.86	0.85
	0.96	0.79	0.94	0.86	0.86	0.82
	0.43	0.75	0.83	0.81	0.85	0.80
	0.62	0.95	0.89	0.82	0.86	0.82
-150	0.66	0.68	0.82	0.96	0.99	0.93
	1.12	1.15	0.93	0.96	1.00	0.95
	0.50	0.97	0.96	0.98	0.90	0.90
	0.76	0.93	0.90	0.97	0.96	0.93

^a Screen openings in sieve series are given in Table 1.

^b Separate portions of the original sample were ground completely to pass screens having the respective meshes indicated. The mechanical composition of the samples is given in Table 3.

^c Original sample as received.

^d Fractions separated from the original sample as received.

2741) ground to different degrees of fineness. The BPI and UT analyses were made on portions of the same samples having the particle-size distributions shown in Table 3, while the TVA data were obtained on other grinds the mechanical compositions of which were reported as follows:

FINENESS	COMPOSITION, MESH					
	-20, +35	-35, +60	-60, +80	-80, +100	-100, +150	-150
<i>mesh</i>	<i>per cent</i>	<i>per cent</i>	<i>per cent</i>	<i>per cent</i>	<i>per cent</i>	<i>per cent</i>
-20	26	25	9	8	10	22
-35	—	40	10	10	14	26
-80	—	—	—	26	25	49

The data for insoluble phosphoric acid (Table 6) are consistent among themselves and with those of Table 5 in showing (1) that with continuous agitation during the citrate digestion the particle-size effect was eliminated by grinding the sample to pass a 35-mesh sieve, (2) that with intermittent agitation, finer grinding was necessary to eliminate this effect, and (3) that with the coarser grinds the agreement among the results by different laboratories was generally poor.

TABLE 6.—*Effect of particle size, sample weight, and type of agitation during citrate digestion on average results for citrate-insoluble P_2O_5 in calcium metaphosphate, as determined by three laboratories*

FINENESS ^a	CITRATE-INSOLUBLE P_2O_5 ^b BY—					
	INTERMITTENT AGITATION ^c			CONTINUOUS AGITATION ^d		
	BPI	TVA ^e	UT ^f	BPI	TVA ^e	UT ^f
<i>mesh</i>	<i>per cent</i>	<i>per cent</i>	<i>per cent</i>	<i>per cent</i>	<i>per cent</i>	<i>per cent</i>
-10 ^g	12.33	—	11.88	7.30	—	4.33 ^h
-20	10.32	7.80	9.36	3.74	3.70	2.72 ⁱ
-35	1.96	2.80	1.75	0.86	0.90	0.77
-80	0.81	0.70	0.60	0.75	0.70	0.72

^a Screen openings in sieve series are given in Table 1. The mechanical composition of the samples is given in Table 3.

^b Determined on 1-gram samples. Prior to the citrate digestions by BPI and TVA the analytical samples were washed with water as directed in the official method for water-soluble P_2O_5 .

^c Manual agitation at 5-minute intervals.

^d Continuous end-over-end agitation in the MacIntire-Marshall-Meyer apparatus.

^e Analyses by O. W. Edwards, Division of Chemical Engineering, Tennessee Valley Authority, Wilson Dam, Ala.

^f Analyses by L. J. Hardin, Chemistry Dept., Univ. Tennessee Agr. Expt. Sta., Knoxville, Tenn.

^g Original sample (No. 2741) as received.

^h Residue from nitric acid digestion of citrate-insoluble residue contained 0.07% P_2O_5 by sodium hydroxide fusion.

ⁱ Trace of P_2O_5 in acid-insoluble residue.

In many fertilizer control laboratories grinding of analytical samples is done by means of high-speed hammer mills fitted with self-contained screens. These mills give generally satisfactory performance on a wide

variety of fertilizers (1, 22) usually with a considerable reduction in the time required for preparing the sample, and their use can be expected to become even more widespread. Because the fineness of the ground material is governed largely by the size of the mill-screen opening, it is important to have information on the relation of the aperture to the distribution of particle size in the prepared samples and to the values for citrate-insoluble phosphoric acid obtained thereon. Such data for calcium metaphosphate and its mixtures with other fertilizer materials are given in Tables 4 and 7.

TABLE 7.-*Effect of size of opening in mill screen and type of agitation during citrate digestion on residue for citrate-insoluble P₂O₅ in calcium metaphosphate material ground in laboratory hammer mill*

SAMPLE NO.	FERTILIZER GRADE	METAPHOSPHATE CONTENT ^a	DIAMETER OF SCREEN OPENING	CITRATE-INSOLUBLE P ₂ O ₅ BY -			
				INTERMITTENT AGITATION		CONTINUOUS AGITATION	
				RANGE	AVERAGE	RANGE	AVERAGE
2829	0-16-16	<i>lb./short ton</i> 125	<i>inch</i> 0.125	<i>per cent</i> 1.05-1.20	<i>per cent</i> 1.11	<i>per cent</i> 0.78-0.93	<i>per cent</i> 0.85
2833	4-16-8	130	0.125 0.0625 0.039	1.19-1.39 1.20-1.25 1.13-1.18	1.27 1.23 1.15	1.08-1.21 1.06-1.17 1.04-1.10	1.13 1.11 1.08
2830	0-20-10	172.5	0.125	1.34-1.48	1.41	1.04-1.12	1.07
2831	0-20-10	300	0.125 0.0625 0.039	1.37-1.40 0.89-1.06 0.81-0.96	1.38 0.99 0.86	0.85-0.96 0.81-0.91 0.74-0.84	0.90 0.86 0.79
2834	0-20-20	645	0.125	0.46-0.63	0.54	0.13-0.32	0.20
2832	0-20-20	665	0.125 0.0625 0.039	1.03-1.07 0.44-0.69 0.42-0.49	1.05 0.54 0.46	0.48-0.64 0.36-0.40 0.28-0.39	0.57 0.38 0.34
2741	-	2,000	0.125 0.0625 0.039	3.46-4.15 2.21-2.42 1.43-1.58	3.85 2.33 1.49	1.14-1.54 0.83-1.08 0.69-0.82	1.34 0.99 0.75

^a As reported by manufacturers.

^b Triplicate determinations on 1-gram samples. Partial mechanical analyses of most of the grinds are given in Table 4.

With a mill screen having circular openings 0.125 inch in diameter, less than 1 per cent of the ground sample was retained on a 20-mesh sieve, 90 to 97 per cent passed a 35-mesh sieve, and 69 to 89 per cent was finer than 60 mesh (Table 4). Further increases in fineness were obtained by reducing the diameter of the openings to 0.0625 and 0.039 inch, respectively.

The effect of the size of the mill-screen opening on the values for insoluble phosphoric acid in the mixed fertilizers was small, regardless of

the method of agitation during the citrate digestion (Table 7). In the case of straight metaphosphate the values were generally more sensitive to differences in the screen openings and in the method of agitation, as might be predicted from the data of Tables 3, 4, and 5.

GREENHOUSE PROCEDURE

Six particle-size fractions of the calcium metaphosphate (Table 8) were compared with triple superphosphate (-35 mesh) as sources of phosphorus for German millet grown in 2-gallon glazed pots, each containing 21 pounds (air-dry basis) of Evesboro sandy loam soil (-14 mesh) from the Beltsville Research Center, Beltsville, Maryland. The pots (3 replicates) were arranged in randomized blocks. The air-dry field soil, which was high deficient in phosphorus for growth of millet, had a *pH* of approximately 4.8.

Each pot received basal treatments of ground dolomite (-100 mesh), nitrogen (as ammonium sulfate), and K_2O (as potassium chloride) at rates of 2,000, 75, and 150 pounds per acre, respectively, mixed with all the soil on April 25, 1950. On the following day the phosphorus carriers were applied at rates of 25, 50, and 100 pounds of total phosphoric acid per acre, respectively, in the top third (3 inches) of the soil by removing the requisite weight of soil from the pot and mixing in the fertilizer. Minor elements were subsequently applied as a solution to the surface of the soil in quantity to supply boron 1, copper 0.5, zinc 0.1, manganese 0.1, and iron 0.5 part per million parts of soil.

The millet was planted on April 27 at the rate of 33 equally spaced seeds per pot, thinned to 15 plants per pot on May 15, and then to 10 plants on May 22. The plants, in partial head, were harvested on June 19, 51 days after emergence.

During the experiment the moisture content of the soil was maintained at approximately 11 per cent by addition of tap water.

RESULTS OF GREENHOUSE EXPERIMENT

Large differences between the fertilizer value of -35, +60 mesh calcium metaphosphate and that of the -10, +20 and the -20, +35 mesh fractions of this material were obtained at all the rates of phosphoric acid application (Table 8) and, with one exception, the differences were statistically significant at the 5 per cent or a higher level (Table 9). The yields with triple superphosphate were markedly higher than those with the -10, +20 and -20, +35 mesh fractions of metaphosphate at the same rates of application, and the differences were statistically significant at the 1 per cent level. Triple superphosphate also gave statistically higher yields than the -35, +60 and -60, +80 mesh metaphosphate fractions at an application rate of 50 pounds of total phosphoric acid per acre but not at the other rates. In some instances the yields with

metaphosphate were higher than those with equivalent applications of triple superphosphate, but in no case was the difference significant.

TABLE 8.—*Effect of particle size of calcium metaphosphate on oven-dry yields of millet grown on Evesboro sandy loam soil*

FINENESS OF METAPHOSPHATE ^a	DRY WEIGHT OF PLANTS PER POT ^b AT P ₂ O ₅ APPLICATIONS OF—					
	25 LB. PER ACRE		50 LB. PER ACRE		100 LB. PER ACRE	
	RANGE	AVERAGE	RANGE	AVERAGE	RANGE	AVERAGE
<i>mesh</i>	<i>grams</i>	<i>grams</i>	<i>grams</i>	<i>grams</i>	<i>grams</i>	<i>grams</i>
-10, + 20	11.18-11.37	11.29	13.01-16.77	15.00	18.18-19.69	18.92
-20, + 35	9.72-15.37	12.76	15.62-17.66	16.76	17.77-21.96	19.57
-35, + 60	14.66-16.05	15.44	19.53-22.57	20.57	24.10-26.68	25.05
-60, + 80	14.81-19.47	16.94	17.60-21.17	19.62	22.61-27.27	25.02
-80, +150	16.80-19.08	18.22	20.60-24.15	22.29	26.47-29.25	27.57
-150	15.34-22.31	18.66	20.08-23.69	21.51	24.85-25.13	24.95
Triple super-phosphate ^c	16.11-20.61	17.64	20.70-26.86	24.76	24.81-28.27	26.45

^a Fractions separated from the original sample as received.

^b Dry weights of plants without applied phosphorus were 5.86 to 8.76 grams, average 6.92 grams. Differences in average dry weights required for significance are 3.29 grams at 5% level and 4.40 grams at 1% level.

^c Ground to pass the 35-mesh sieve.

TABLE 9.—*Statistically significant differences among average yields of millet from various treatments*

MESH OF CALCIUM METAPHOSPHATE	RATE OF P ₂ O ₅ APPLICATION IN POUNDS PER ACRE ^a		
	25	50	100
Particle-size fractions of metaphosphate			
-10, +20 vs. -35, +60	*	**	**
-20, +35 vs. -35, +60	—	*	**
Particle-size fractions of metaphosphate vs. triple superphosphate			
-10, +20	**	**	**
-20, +35	**	**	**
-35, +60	—	*	—
-60, +80	—	**	—

^a One and two asterisks denote that the differences are significant at the 5% and 1% levels, respectively.

On the basis of these data it appears that particles of calcium metaphosphate coarser than 35 mesh are relatively poor sources of phosphorus for the first crop following the phosphate application.

RELATION OF FERTILIZER EFFICIENCY TO CITRATE SOLUBILITY

The relation of the particle size of calcium metaphosphate to its fertilizer efficiency and citrate solubility is clearly shown in Figure 1, where

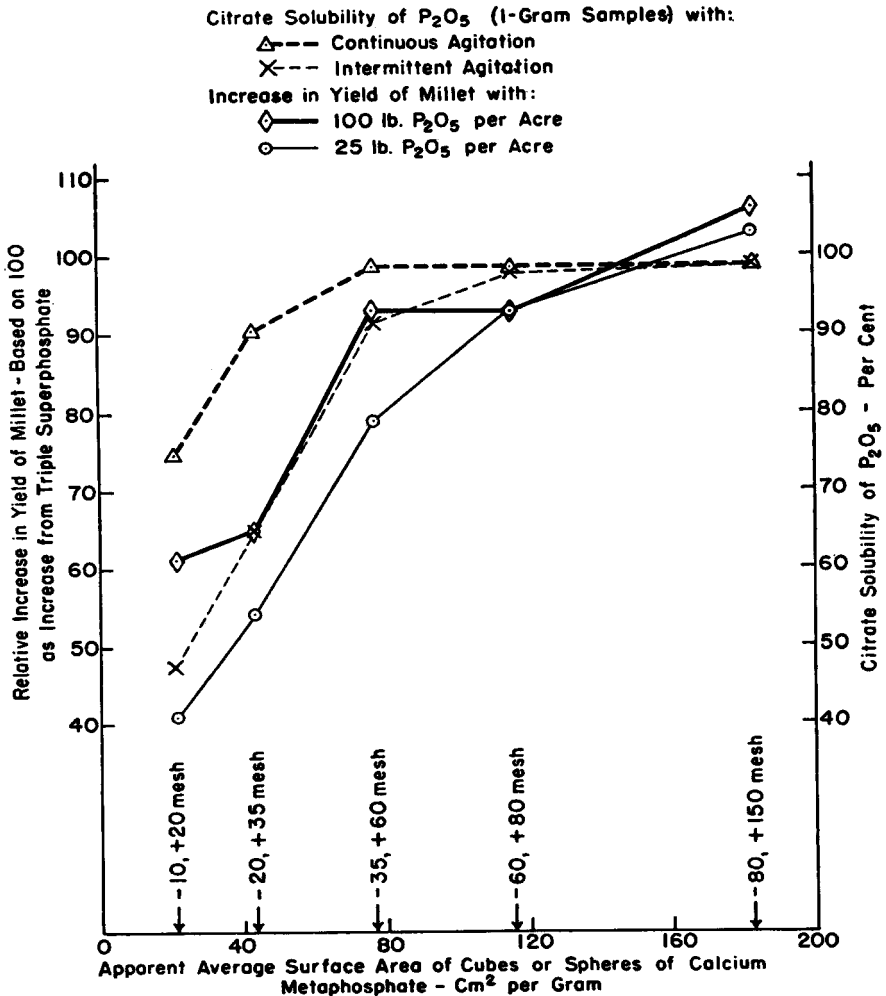

FIG. 1.—Relation of particle size of calcium metaphosphate to its fertilizer efficiency and citrate solubility.

the citrate solubility of the phosphoric acid in the metaphosphate and the relative increase in yield of millet resulting from metaphosphate applications, based on 100 as the increase from equivalent applications of triple superphosphate, are plotted against the average surface area of several mesh sizes of metaphosphate. The indicated values for the average surface area of the particles are based on the assumptions that

the particles are nonporous cubes or spheres and that the distribution of particle size on the weight bases is uniform (Table 1). Although these assumptions are not necessarily valid, use of the true surface-area values would merely shift the position of the points along the horizontal axes and would not change the relationship among the several curves.

It will be noted that the relative efficiencies of the different particle sizes of calcium metaphosphate in increasing the yield of millet paralleled and were generally close to the values for the solubility of the phosphoric acid as determined with the aid of intermittent agitation during the citrate digestion. With continuous agitation during the citrate digestion, however, the solubility values for the coarser particles of metaphosphate were markedly higher than the relative fertilizer efficiencies of the phosphoric acid in these particles.

DISCUSSION

Although it appears that, even with intermittent agitation during the citrate digestion, the official method for available phosphoric acid does not underrate the fertilizer efficiency of straight, coarsely ground metaphosphate—at least for the first crop following its application—direct analysis of such material without further grinding may result in discordant values for citrate-insoluble phosphoric acid (Tables 5 and 6). On the other hand, grinding of the analytical sample may lead to a considerable overrating of coarse metaphosphate in relation to its value for immediate use by crops.

On the basis of the present information one can come only to the conclusion that the determination of available phosphoric acid in straight metaphosphate should be made directly on the material in the particle-size condition as marketed, even though this involves sacrifice of precision in the analysis. This conclusion is to be regarded, of course, as strictly tentative. Additional plant-growth experiments with closely sized particles of metaphosphate are needed to establish, or disprove, its validity.

Phosphate materials lose their identity when they are included in mixed fertilizers, and the State fertilizer control chemist usually does not know and has no way of easily determining the source of phosphoric acid in mixtures. For this and other reasons it is not practicable, as regards the preparation of the analytical sample, to differentiate mixtures containing calcium metaphosphate from those not containing this material.

Bearing in mind the fact that the effects of particle size on the fertilizer value of calcium metaphosphate, as well as on its citrate solubility, appear to be substantially eliminated by grinding the material to pass a 35-mesh sieve, it would seem important that the marketed product be of this fineness.

SUMMARY AND CONCLUSIONS

Calcium metaphosphate glass is being marketed for fertilizer purposes in the form of a -10 mesh product containing about 15 per cent by weight of particles coarser than 20 mesh and 50 per cent coarser than 35 mesh.

The relation of the particle size of a typical metaphosphate to the citrate solubility of its phosphoric acid was studied over a wide range of sample fineness and with variations in the sample weight and the degree of agitation during the citrate digestion. Similar though less extensive data were obtained on six samples of experimental formulas of mixed fertilizers in which all or a part of the phosphoric acid was supplied by metaphosphate. A greenhouse study was also made of the fertilizer efficiency of closely sized particles of the metaphosphate.

With continuous agitation during the citrate digestion the effect of particle size on phosphoric acid solubility virtually disappeared when the metaphosphate was ground to pass a 35-mesh sieve. Likewise, virtually constant solubility values were obtained on -35, +60 mesh and finer fractions of material separated from the original metaphosphate. With intermittent agitation (shaking at 5-minute intervals) a higher degree of fineness was required to eliminate the particle-size effect, namely, -60 mesh for the gross grind and -80, +150 mesh for the mechanical fractions.

Compared to triple superphosphate, calcium metaphosphate of particle size coarser than 35 mesh was a poor source of phosphoric acid for millet in the greenhouse. The relative efficiencies of different particle sizes of metaphosphate in increasing the dry-weight yields of millet paralleled and were generally close to the values for the solubility of the phosphoric acid as determined with the aid of intermittent agitation during the citrate digestion. With continuous agitation during the citrate digestion the solubility values for the coarser particles (+35 mesh) were markedly higher than the relative fertilizer efficiencies of the phosphoric acid in these particles.

The tentative conclusion is advanced that determinations of available phosphoric acid in calcium metaphosphate should be made directly on the material in the particle-size condition as marketed. Additional plant-growth experiments with closely sized particles of metaphosphate are needed to establish, or disprove, this conclusion.

DETERMINATION OF TOTAL P_2O_5 IN CALCIUM METAPHOSPHATE

Accurate determination of total phosphoric acid in calcium metaphosphate requires not only solution of the phosphorus but also its hydration to the orthophosphate form prior to the molybdate precipitation. Methods of accomplishing these requirements have been studied by Hoffman and Lundell (11), MacIntire, Hardin, and Oldham (17), and very recently by

Brabson and Edwards (3). The latter workers recommend digestion of the sample for 15 minutes in a mixture of 15 to 30 ml of hydrochloric acid and 3 to 10 ml of nitric acid, as prescribed in the *Methods of Analysis*, 1945, p. 22, sec. 2.8(b). They show that this procedure is applicable to the type of calcium metaphosphate presently being marketed and, at least, to some kinds of mixed fertilizers in which all or a part of the phosphoric acid is supplied as metaphosphate. The procedure should be subjected to collaborative study with the view to its official designation for metaphosphate products.

PRESERVATION OF MOLYBDATE SOLUTIONS

Investigation of the aging and preservation of the molybdate solution used in the volumetric method for phosphoric acid was undertaken, but the study has not progressed sufficiently to justify a report at this time.

ACKNOWLEDGMENT

The authors wish to express their appreciation to the Tennessee Valley Authority for the sample of calcium metaphosphate used in this study and for the cooperation given by several members of the Authority's staff, as well as to the several manufacturers who supplied the samples of mixed fertilizers containing metaphosphate.

Assistance in the various phases of the investigation was rendered by D. V. Bennett, A. V. Breen, W. L. Hill, R. M. Magness, and T. M. Sheets, all of the Division of Fertilizer and Agricultural Lime.

RECOMMENDATIONS"

It is recommended-

(1) That alpha phosphate (defluorinated phosphate rock) and phosphate rock-magnesium silicate glass be evaluated by the neutral ammonium citrate method, preferably with continuous agitation during the citrate digestion, and made official.

(2) That work be continued on the evaluation of calcium metaphosphate by the neutral ammonium citrate method, with special reference to the relation of the particle size of the material to its citrate solubility and fertilizer efficiency.

(3) That work on methods for phosphoric acid in fertilizers be continued, with emphasis on:

(a) Aging of the molybdate solution used in the volumetric method, to determine if a time limit should be put on its use or an addition made to preserve it.

(b) Preparation of solutions of calcium metaphosphate for determination of total phosphoric acid.

(c) Use of perchloric acid in preparation of solutions for analysis.

LITERATURE CITED

- (1) ALLEN, H. R., *This Journal*, 33, 229-234 (1950).
 - (2) ALWAY, F. J., and NESOM, G. H., *J. Am. Soc. Agron.*, 36, 73-88 (1944).
 - (3) BRABSON, J. A., and EDWARDS, O. W., Reported at 64th Annual Meeting, A.O.A.C., Oct. 3, 1950.
 - (4) BROWN, B. E., and CLARK, K. G., *Am. Fertilizer*, 98, No.5, 10-11, 24, 26 (1943).
 - (5) COPSON, R. L., POLE, G. R., and BASKERVILL, W. H., *Ind. Eng. Chem.*, 34, 26-32 (1942).
 - (6) CURTIS, H. A., *Tenn. Valley Authority*, Chem. Eng. Rept. I, revised, 60 pp. (1948).
 - (7) — — —, COPSON, R. L., ABRAMS, A. J., and JUNKINS, J. N., *Chem. & Met. Eng.*, 45, 318-322 (1938).
 - (8) ENSMINGER, L. E., *Ala. Agr. Expt. Sta. Bull.* 270, 39 pp. (1950).
 - (9) HILL, W. L., *Assoc. Am. Fertilizer Control Officials Official Pub.* 1947, [1-10].
 - (10) — — —, WARD, F. N., ARMIGER, W. H., and JACOB, K. D., *This Journal*, 31, 381-397 (1948).
 - (11) HOFFMAN, J. I., and LUNDELL, G. E. F., *J. Research Natl. Bur. Standards*, 19, 59-64 (1937).
 - (12) HOUGHLAND, G. V. C., CLARK, K. G., HAWKINS, A., and CAMPBELL, J. C., *Am. Fertilizer*, 97, No.7, 5-8, 24, 26 (1942).
 - (13) JACOB, K. D., MAGNESS, R. M., and WHITTAKER, C. W., *This Journal*, 33, 234-260 (1950).
 - (14) — — —, RADER, L. F., JR., and TREMBARNE, T. H., *Ibid.*, 19, 449-472 (1936).
 - (15) — — —, WARD, F. N., HILL, W. L., and PINKERTON, C., *Ibid.*, 30, 529-548 (1947).
 - (16) — — —, WARD, F. N., MAGNESS, R. M., and WHITTAKER, C. W., *Ibid.*, 32, 202-228 (1949).
 - (17) MACINTIRE, W. H., HARDIN, L. J., and OLDHAM, F. D., *Ind. Eng. Chem.*, 29, 224-234 (1937).
 - (18) — — —, MARSHALL, H. L., and MEYER, T. A., *This Journal*, 27, 272-283 (1944).
 - (19) O'BRIEN, R. E., *Va. Agr. Expt. Sta. Bull.* 364, 26 pp. (1944).
 - (20) RICH, C. I., and LUTZ, J. A., JR., *Va. Agr. Expt. Sta. Tech. Bull.* 115, 14 pp. (1950).
 - (21) ROBERTS, G., FREEMAN, J. F., and MILLER, H., *Ky. Agr. Expt. Sta. Bull.* 420, 32 pp. (1942).
 - (22) ROSS, W. H., and HARDESTY, J. O., *This Journal*, 25, 238-246 (1942).
 - (23) — — —, and JACOB, K. D., *Ibid.*, 20, 231-249 (1937).
 - (24) Tennessee Valley Authority, "The Relative Efficiency of Calcium Metaphosphate as a Phosphatic Fertilizer and the Effect of Particle Size on 'Availability' as Measured by Chemical Methods and Plant Growth Tests," 15 pp., Jan. 17, 1950. Processed.
 - (25) VOLK, G. W., *J. Am. Soc. Agron.*, 36, 46-56 (1944).
-

REPORT ON FREE WATER IN FERTILIZERS
WATER CONTENT OF SUNDRY FERTILIZERS SHOWN BY
OFFICIAL METHODS

By W. L. HILL, J. H. CARO, and R. KUMAGAI (Division of Fertilizer and Agricultural Lime, Bureau of Plant Industry, Soils, and Agricultural Engineering, Agricultural Research Administration, U. S. Department of Agriculture, Beltsville, Maryland)

A recommended¹ and approved² study was made of the applicability of the official methods—airflow at 60°, vacuum desiccation at room temperature, and oven drying at 1000-to sundry fertilizers and fertilizer materials. Results by oven drying at 130° were obtained with a view towards the possible selection of a single stated temperature in the procedure for oven drying. The results are presented in this report.

MATERIALS AND METHODS

The materials chosen for the study are listed and described in Table I. The analytical samples were ground to pass a 35-mesh sieve (500-micron openings). The water determinations on each sample by the several procedures were made at the same time, in order to eliminate as far as practicable variability arising from sample alteration with time and from differences in atmospheric conditions. The tared samples were dried for the selected periods of time (0.5, 1, 2, 4, 6 and 20 hours, respectively) with intervening cooling and weighing to determine the progress of drying. Free phosphoric acid was put on calcium sulfate and monocalcium phosphate by drenching the acid-free material with an ether solution of 40% aqueous acid and allowing the ether to evaporate at 35 to 40°.

RESULTS AND DISCUSSION

The weight losses observed on the several materials by the different procedures are plotted against the time of drying in Figures 1 to 9, inclusive. Ammonium sulfate (Figure 1) serves as a standard material in the sense that all procedures should give substantially the same figure for water, provided air drying can be avoided during the time successive samples are being weighed from the bottle. Since observed results range from 1 to 0.8% of water in the order in which the samples were weighed out, the differences between the results by the several methods are attributed to rapid drying of the analytical samples during successive weighings in the conventional manner.

The data depicted in the figures afford a simple criterion of performance of a procedure. A reliable procedure is one that produces a definite weight loss within a reasonably short period of drying—a condition that is

¹ *This Journal*, 32, 228 (1949); 33, 260 (1950).

² *This Journal*, 32, 44 (1949); 33, 38 (1950).

TABLE I.-Description of materials

SAMPLE NO.	MATERIAL	WATER OF CRYSTALLIZATION AND GRADE	
2733	Ammonium sulfate	-	fertilizer
2692	Calcium sulfate	2H:O	reagent
2328	Monocalcium phosphate	1H:O	food
2626	Monoammonium phosphate	-	tech. pwdr.
1885	Monoammonium phosphate	-	fertilizer
2601	Monomagnesium phosphate	4H:Ob	reagent
-	Phosphoric acid	-	reagent, 85%
2694	Diammonium phosphate	-	reagent
2608	Dicalcium phosphate	2H:Oo	food
2601 ^b	Dimagnesium phosphate	3H:O	reagent
2439	Magnesium ammonium phosphate	1H:O	reagent
2691	Magnesium ammonium phosphate	6H:O	reagent
2631	Ordinary superphosphate	-	cured run of piled
2734	Ordinary superphosphate	3.25%	fresh run of pile ^c
2633	Amm.oniated superphosphate	-	total P:O ₅ , 20%. C.I. 2%. NH ₃ 3.16%
2636	Triple superphosphate	-	(1)
2697	Furfural residue	-	fertilizer conditioner
2698	Rice hulls	-	fertilizer conditioner
46022	Cocoa shell meal	-	fertilizer conditioner
2695	Mixed fertilizer ^e	-	3-12-6
2696	Mixed fertilizer ^h	-	10-10-10

^a Loss on ignition at 600° was 19.3, in comparison with 20.9% required by formula.

^b Total water was 38.4%, in comparison with 37.2% required by formula.

^c This material, which had been stored in the laboratory several months, contained only 12.0% water of crystallization.

^d Total P₂O₅ 20.6%, C.I. 0.5%, free H₃PO₄ and water by ether extraction, 0.3 and 1.13%, respectively.

^e Total P₂O₅ 20%, C.I. 0.7%, free H₃PO₄ and water by ether extraction, 1.3 and 2.2%, respectively.

^f Total P₂O₅ 48.8%, C.I. 2%, free H₃PO₄ and water by ether extraction, 0.1 and 0.4%, respectively.

^g Superphosphate 1335, N solution No. 2 150, vegetable tankage 150, potassium chloride 200, kemidol oxide (MgO) 15, dolomits 31, sand 119 lb., respectively.

^h Superphosphate 782, triple superphosphate 100, N solution No. 2 200, ammonium nitrate 200, ammonium sulfate 278, potassium chloride 330, dolomite 110 lb. respectively.

characterized by a drying curve like those for ammonium sulfate that is very steep for short drying periods and then levels off into a substantially horizontal line. With the use of this criterion it is seen that, for the 23 materials studied, vacuum desiccation up to 4 hours is a satisfactory procedure in all but four cases (phosphoric acid, fresh ordinary superphosphate, rice hulls and cocoa shell meal). Likewise, airflow at 60° for periods up to 4 hours is an acceptable procedure in all but four instances (hydrated calcium sulfate containing a little free phosphoric acid, monomagnesium phosphate, diammonium phosphate, and magnesium ammonium phosphate hexahydrate) exclusive of liquid phosphoric acid to which the method is inapplicable for mechanical reasons. Since only phosphoric acid appears in both lists of exceptions, either one or the other, and often both, of the procedures is applicable to 22 of the 23 materials included in this study.

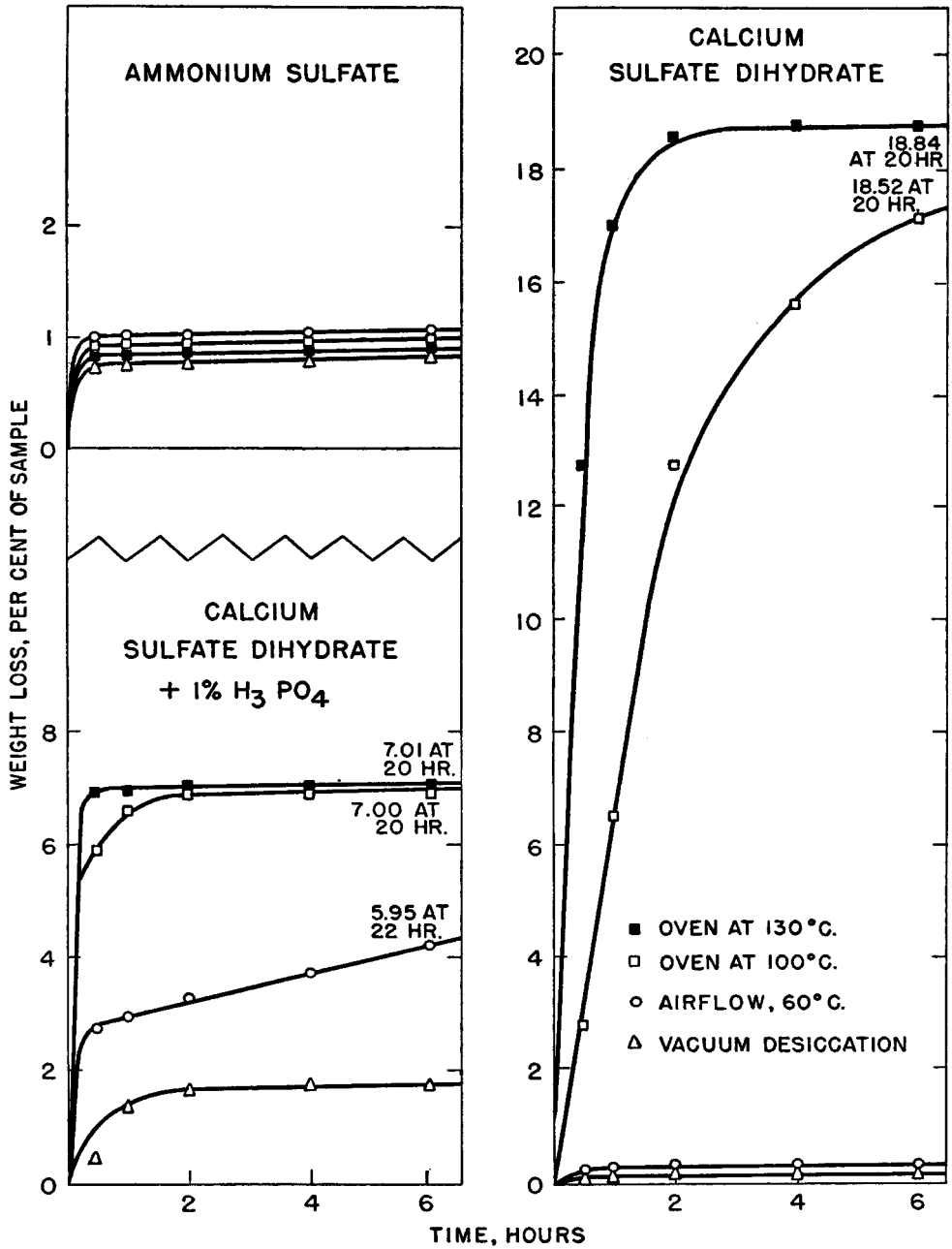

FIG. 1.—Behavior of ammonium and calcium sulfates.

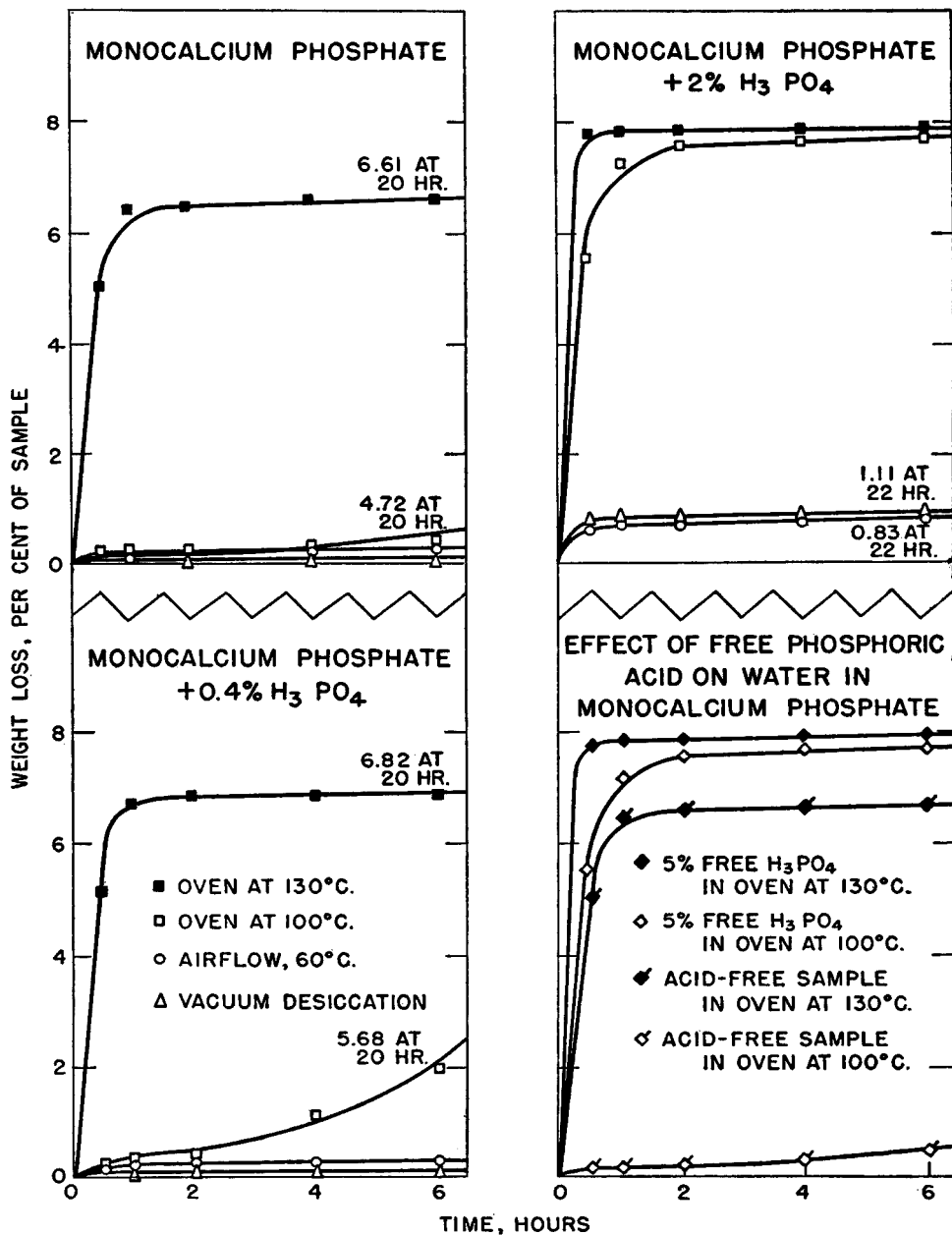

FIG. 2.—Behavior of monocalcium phosphate monohydrate with and without free phosphoric acid.

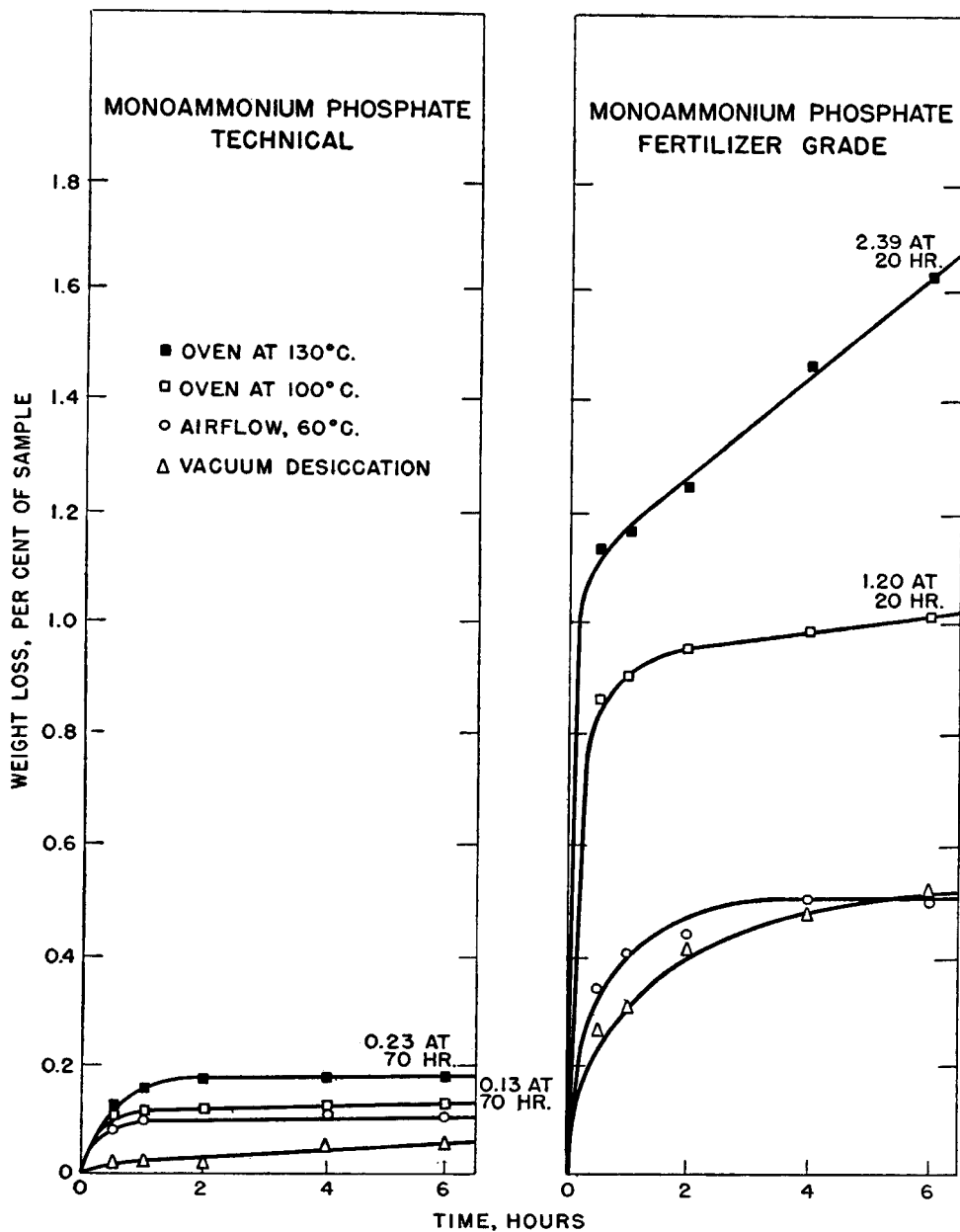

Fig. 3.—Behavior of monoammonium phosphate.

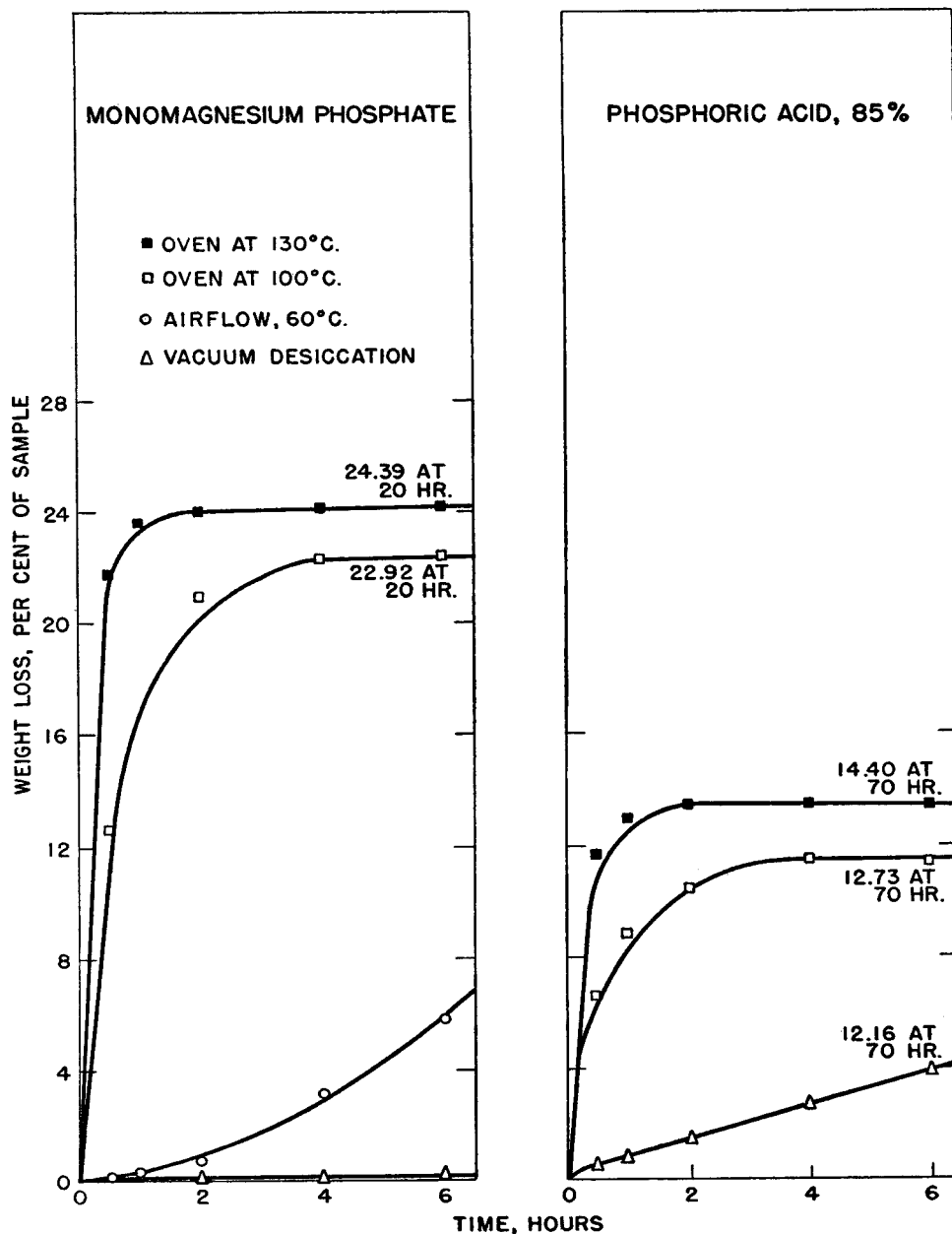

FIG. 4.—Behavior of monomagnesium phosphate and 85% phosphoric acid.

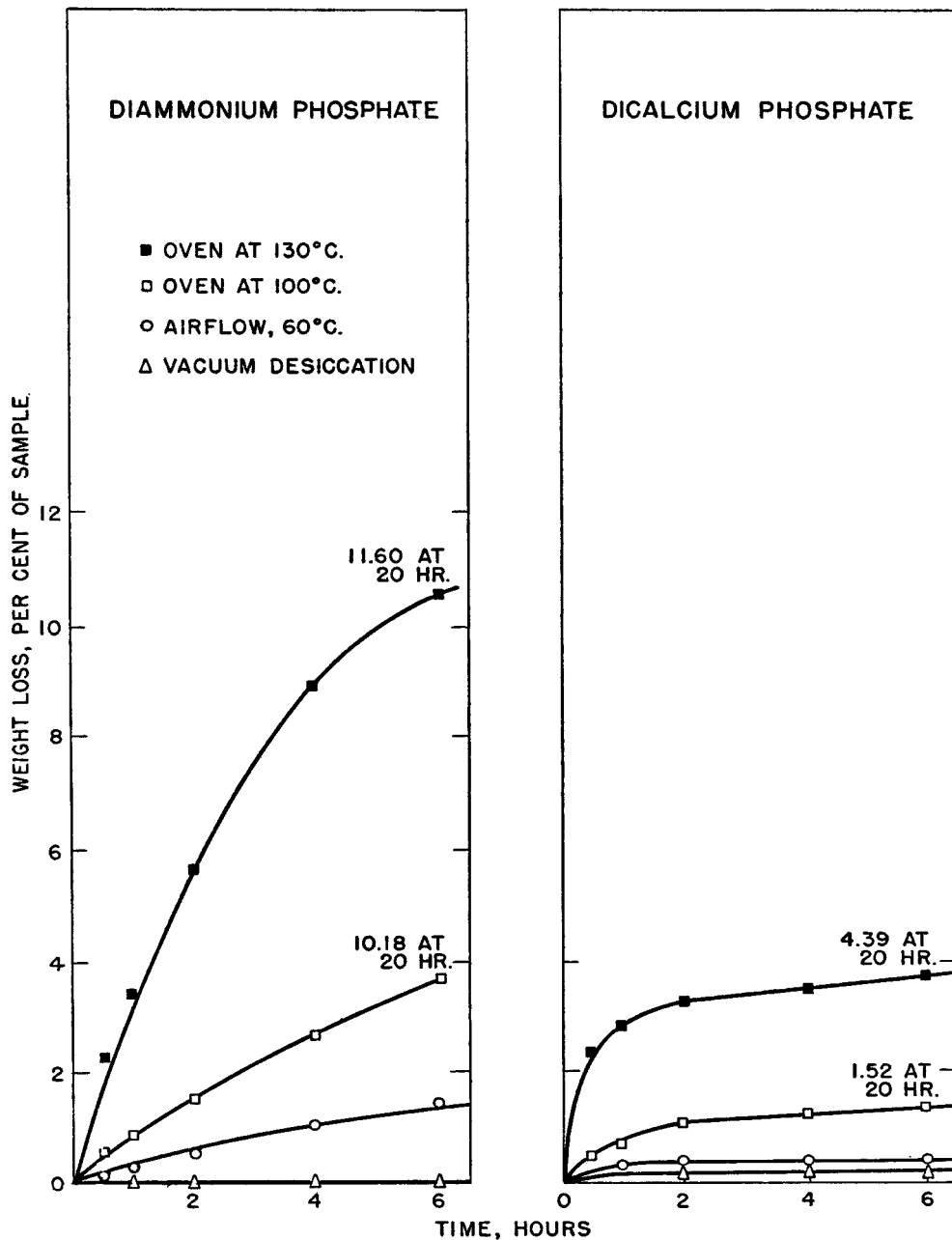

Fig. 5.—Behavior of diammonium and dicalcium phosphates.

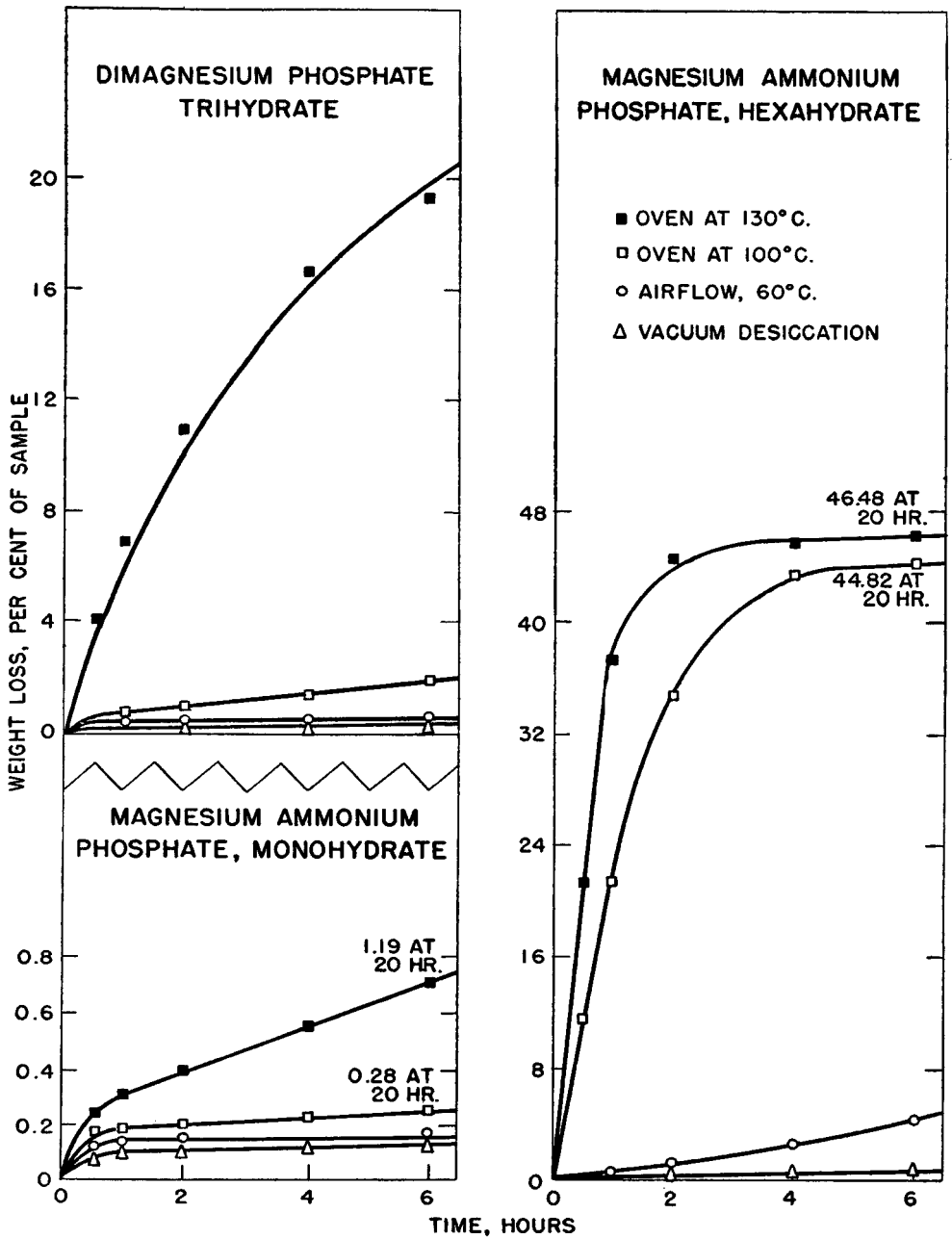

FIG. 6.—Behavior of dimagnesium and magnesium ammonium phosphates.

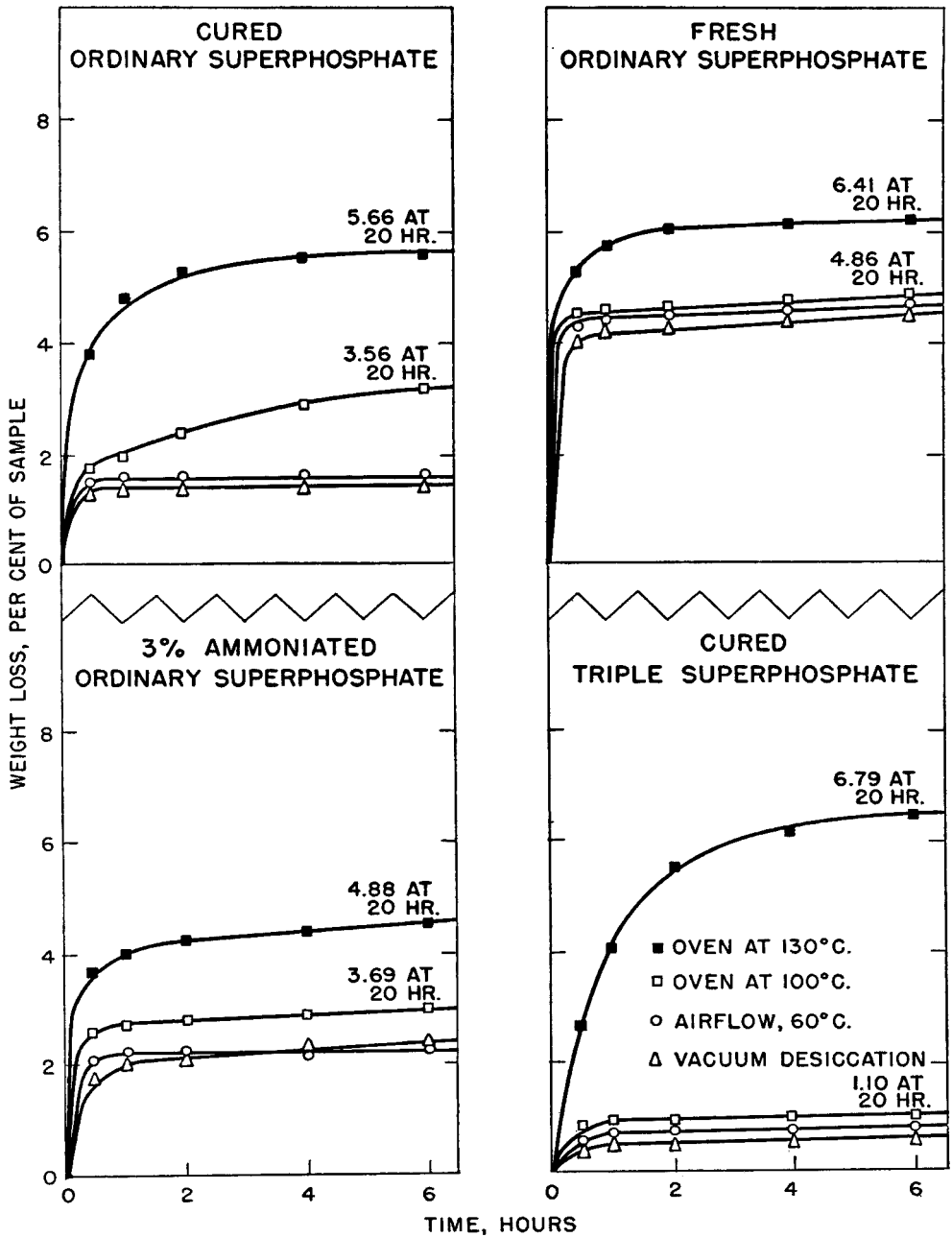

FIG. 7.—Behavior of superphosphates.

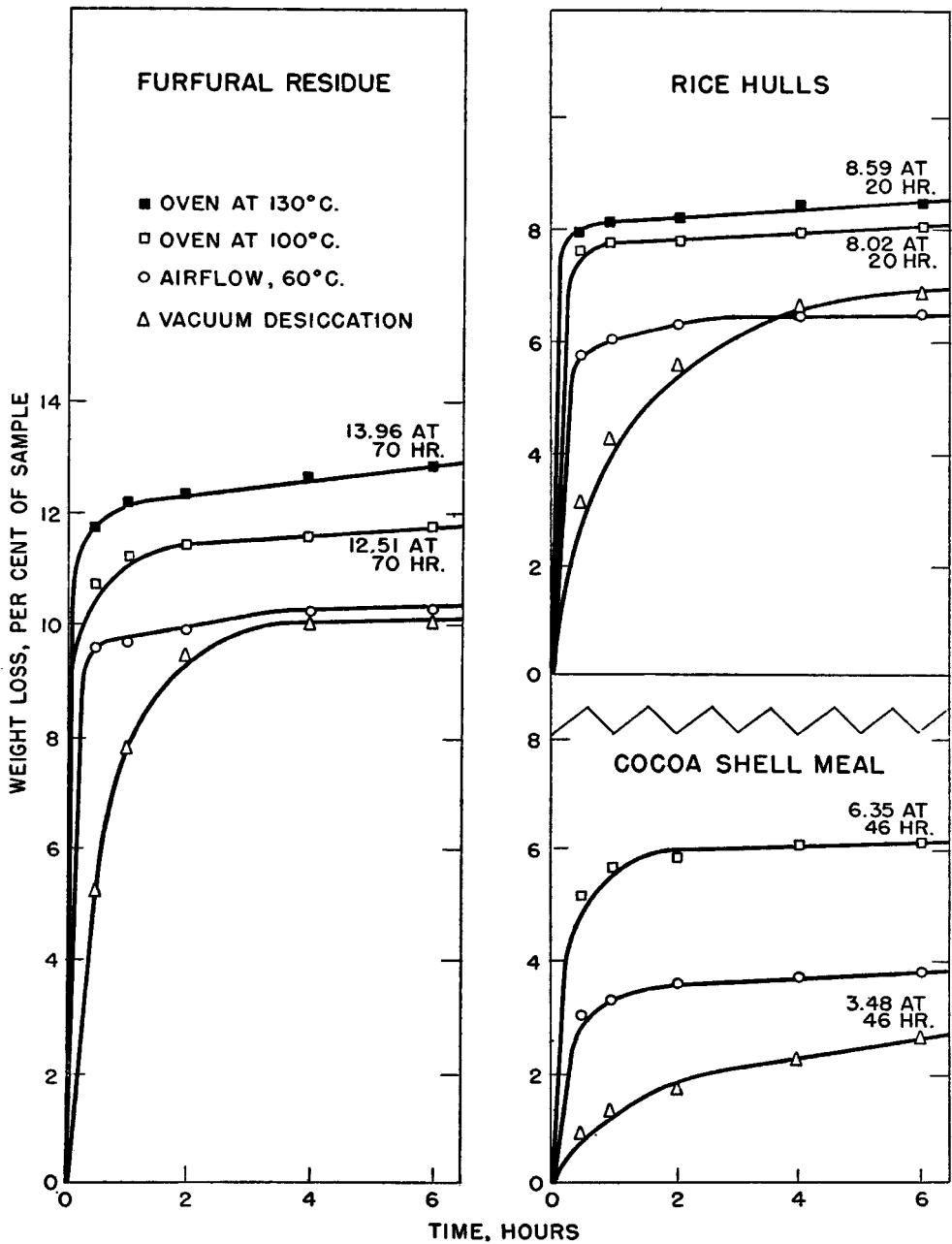

FIG. 8.—Behavior of organic conditioners.

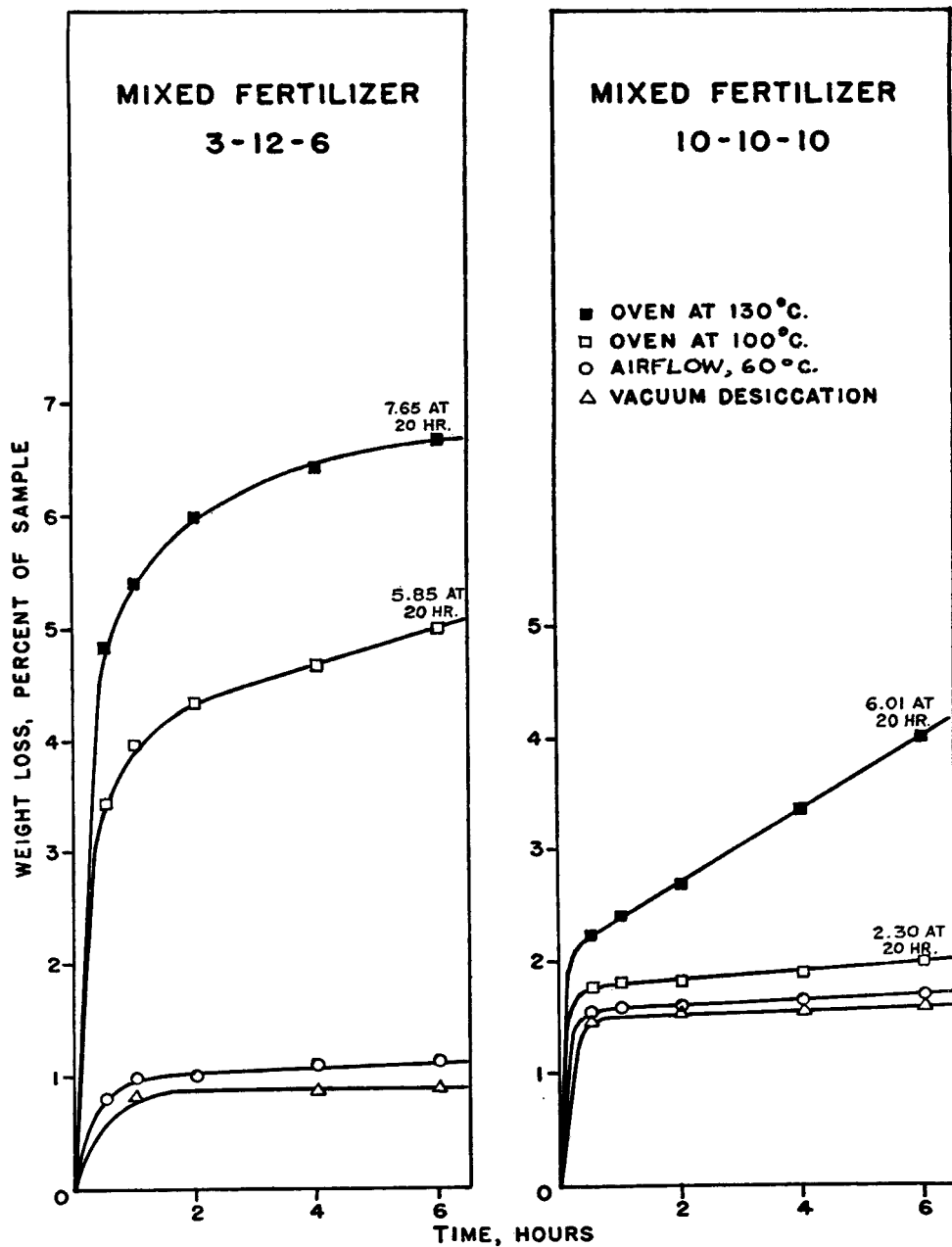

FIG. 9.—Behavior of mixed fertilizers.

In accordance with the same standard of performance the oven drying procedures at 100° and 130° are unsatisfactory for 12 and 10 of the materials, respectively, among which nine are common to the two procedures, namely: fertilizer-grade monoammonium phosphate, the three dibasic phosphates, monohydrated magnesium ammonium phosphate, ammoniated superphosphate, furfural residue, and both mixed fertilizers. Oven drying at 100° is also unsatisfactory for hydrated calcium sulfate (acid-free), monocalcium phosphate containing very small amounts of free phosphoric acid, and cured superphosphate, whereas drying at 130° is also unsatisfactory for cured triple superphosphate and rice hulls. Thus, comparison of the results at the two temperatures on the basis of the above-mentioned criterion gives a small but definite advantage to the higher temperature.

Other considerations favor the higher oven temperature. It is official for sodium nitrate, ammonium sulfate, and potassium salts. Moreover, oven drying is the only simple procedure for driving out water of crystallization, and for this reason the stated temperature should be high enough to expel this form of water from as wide a selection of common fertilizer salt hydrates as possible. It happens that monocalcium phosphate containing little or no free phosphoric acid does not give up its water of crystallization promptly, if at all, at 100° (Figure 2); the same is true of cured superphosphate of low free acid content (Figure 7) and of acid-free calcium sulfate (Figure 1). Accordingly, the higher temperature is to be preferred for these materials.

Although interference from volatile substances other than water should be greater at the higher temperature, the differences between ammonia losses at 100° and 130° are not marked (Table 2). Notable amounts of fluorine are expelled with the water when superphosphates are dried at 80° and higher,³ and the amounts probably exceed 0.5% at 130°. Additional data pertaining to this type of interference will have to be obtained before an intelligent recommendation as to temperature can be made.

TABLE 2.-Loss of ammonia during oven drying

SAMPLE NO.	MATERIAL	TOTAL NH ₃	NH ₃ VOLATILIZED ^a AT—	
			100°	130°
		<i>per cent</i>	<i>per cent</i>	<i>per cent</i> ¹
1885	Monoammonium phosphate, fertilizer grade	13.85	0.09	0.17
2633	Ammoniated superphosphate	3.24	0.12	0.17
2439	Magnesium ammonium phosphate, 1H ₂ O	10.32	0.04 ^b	0.04 ^b
2691	Magnesium ammonium phosphate, 6H ₂ O	6.71	3.96	3.31

^a Calculated from the weight loss of sample and the ammonia contents of the dried and undried material.

^b Near limit of experimental measurement.

¹ Hill and Jacob, *This Journal*, 17,487 (1934).

ACKNOWLEDGMENT

The authors are indebted to J. O. Hardesty and T. M. Sheets, of this Bureau, for valuable aid in this study.

RECOMMENDATIONS.

It is recommended-

- (1) That this study be extended to other fertilizer materials and mixtures.
- (2) That the possibilities of other methods for determining water in fertilizers be investigated.

REPORT ON NITROGEN IN FERTILIZERS

By H. A. DAVIS (New Hampshire Agricultural Experiment Station,
University of New Hampshire, Durham, New Hampshire),
Associate Referee

The Associate Referee in his report of last year, *This Journal*, 33, 262 (1950), recommended "that further study be made of high percentage nitrogen in high nitrate-chloride mixtures."

The observation has been made that the official methods, 2.27 and 2.28 (A.O.A.C. 6th Ed.) gave low results when applied to certain fertilizer mixtures, particularly those high in nitrate nitrogen and chloride. Phillip McG. Shuey, of Shuey & Co., Savannah, Ga., has been working on this problem for a considerable time. He has developed a method which seems to give higher results than the official method when applied to such mixtures. The problem has been discussed at considerable length with the former Referee and it appeared advisable to develop a plan for the trial of this method by collaborative work this year. Based upon the work presented in last year's report it was decided to compare the method as proposed by Mr. Shuey¹ with the present official method for total nitrogen in fertilizers.

COLLABORATORS

A letter inviting participation in this project was sent to each collaborator who took part in the work last year, and to some others brought to the Referee's attention. A favorable response was received from twenty-seven of the twenty-nine prospective collaborators. The excellent cooperation and support of those whose names appear in the following list make this report possible. The Associate Referee wishes to take this opportunity to express his appreciation to each collaborator for his contribution to this project.

A. C. Wark and R. L. Willis, New Jersey Exp. Sta., New Brunswick, N. J.

* For report of Subcommittee A and action of the Association, see *This Journal*, 34, 41 (1951).
¹ Personal communication. Method published in *This Journal*, 33, 1003 (1950).

R. F. Serro and O. W. Ford, Indiana Exp. Sta., Lafayette, Ind.
 C. O. Willits, in charge, Analyt. Sec. Eastern Reg. Lab., Philadelphia, Pa.
 J. R. Archer, Int. Min. & Chem. Corp., East Point, Ga.
 R. D. Caldwell, Armour Fertilizer Works, Atlanta, Ga.
 W. S. Thompson, Feed and Fertilizers Lab., Columbus, Ohio
 R. C. Koch and R. E. Rund, Swift & Co., Plant Food Div., Hammond, Ind.
 Howard Hammond, State Laboratories, Bismarck, N. Dak.
 C. V. Marshall, Chem. Lab., Dept. of Agr., Ottawa, Canada
 W. C. Geagley, Mich. Dept. of Agr., Bureau of Chem. Labs., Lansing, Mich.
 A. T. Blackwell, The Davison Chemical Corp., Baltimore, Md.
 Gordon Hart, Chemical Div., State Agr. Dept., Tallahassee, Fla.
 D. B. Bates, Smith-Douglass Co., Norfolk, Va.
 Roland Gilbert, Rhode Island Agr. Exp. Sta., Kingston, R. I.
 Ralph D. Miller, Spencer Chemical Co., Pittsburg, Kansas
 Philip McG. Shuey, Shuey & Co., Savannah, Ga.
 H. L. Marshall, Mathieson Chemical Corp., Baltimore, Md.
 G. C. Ballinger and C. M. Fleming, The Am. Agr. Chem. Co., Baltimore, Md.
 C. O. Hurst and M. P. Etheredge, Miss. State Chem. Lab., State College, Miss.
 William Chapman, Consolidated Rendering Co., Boston, Mass.
 R. E. Kramer and H. A. Davis, New Hampshire Agr. Exp. Sta., Durham, N. H.

SAMPLES

Five samples were mailed late in April to each collaborator who indicated a desire to participate in the work. They are described as follows:

1. 6- 9-27 This was a commercial mixture obtained and prepared for analysis by Mr. Shuey. (Medium in nitrate nitrogen)
2. 13- 8-18 A mixture made up by Mr. Shuey using ammonium nitrate, cyanamid, muriate of potash and superphosphate. (High in nitrate nitrogen)
3. ~~6-~~ 3-24 A mixture made up in this laboratory using sodium nitrate, muriate of potash, superphosphate and a small amount of dried manure to furnish organic matter. The purpose of this preparation was to furnish a sample comparable to No.2 but with the nitrate nitrogen supplied by sodium nitrate. The suggestion has been made that there is less loss when the nitrate is present as the sodium salt. (High in nitrate nitrogen)
4. 8-16-16 A commercial fertilizer mixture. (Medium in nitrate nitrogen)
5. ~~5-~~ 8- 7 A commercial fertilizer mixture. (Low in nitrate nitrogen)

NOTE: Samples 4 and 5 were furnished by the Consolidated Rendering Co., Boston, Massachusetts. They were prepared for analysis in this laboratory

INSTRUCTIONS TO COLLABORATORS

The following information was given the collaborators regarding the samples:

- No. 1. 6- 9-27 mixture contains about 23 mg nitrate N per gram
 No.2. 13- 8-18 mixture contains about 62 mg nitrate N per gram
 No.3. 6- 3-24 mixture contains about 66 mg nitrate N per gram
 No.4. 8-16-16 mixture contains about 19 mg nitrate N per gram
 No.5. 5- 8- 7 mixture contains about 8 mg nitrate N per gram

The collaborators were asked to analyze these samples by the following methods

- A. The Official Method, *Book of Methods*, 1945, section 2.27 or 2.28, with this exception: Use 2 g of salicylic acid in 30 ml of H_2SO_4 as recommended by the Referee last year in place of 1 gm as specified.
- B. The Shuey Method for the Determination of Nitrogen in High Nitrate-High Chloride Fertilizers in Presence of Cyanamid, and Organic Matter.¹ Details as follows:
- (1) Weigh the sample (0.5000-1.000 g according to the nitrogen content) and transfer to a Kjeldahl flask.
 - (2) Add sufficient Devarda's alloy, 40 mesh and finer, to reduce nitrate nitrogen present. (1 g for each 35 milligrams of nitrate nitrogen that may be present; 2 g usually sufficient.)
 - (3) Wash down neck of the flask with approximately 125 ml distilled water.
 - (4) Add a few drops of mineral oil and approximately 1 ml of tributyl phosphate to control foaming.
 - (5) Add 5 m. strong caustic soda, approximately 50%, such as used regularly in nitrogen determination.
 - (6) Connect at once with the regular condenser and distil until only 10 to 25 ml remains in the flask. Sufficient standard acid should have been placed, in the receiver flask for the total nitrogen present. Kjeldahl and receiver flasks should be marked identically to avoid mix up. Heat applied moderately for first 5 minutes. This distillation is completed in approximately 30 minutes additional.
 - (7) Cool flask and add 5 ml dilute (1:1) H_2SO_4 followed by 25 ml concentrated H_2SO_4 and approximately 0.7 g. HgO (CuSO. may be used in place of the HgO as the catalyst if desired. K_2SO_4 is purposely omitted to prevent caking on cooling).
 - (8) The small remaining quantity of water is boiled off over strong heat and the digestion completed without lowering the flame. (About 30 minutes when mercury is used.)
 - (9) Finish as in the regular Kjeldahl method.

NOTE 1. To check complete reduction of nitrate transfer a drop of residual liquid by means of a long capillary glass tube to a spot plate. Add a minute quantity of brucine sulphate followed by a drop of concentrated H_2SO_4 . No coloration shows complete absence of nitrates. There should be complete absence of the odor of ammonia when the flask has been disconnected.

NOTE 2. Be sure to connect the Kjeldahl flask for final distillation to the corresponding receiver used in step 6 above.

NOTE 3. About 1 g 30 mesh granular zinc or about 2½ g broken pumice ranging from size of a small pea to dust may be used to prevent bumping. Zinc dust does not prevent it.

NOTE 4. A mixed indicator (1.250 g methyl red, 0.825 g methylene blue (for bacilli) in 1 liter of alcohol) (*Anal. Ed.* vol. 2, 1930) may be used instead of methyl red alone. The mixed indicator is much more sensitive and it to be recommended.

A copy of the following form was furnished each collaborator for reply:

REPORT OF ANALYSIS

1950 Collaborative Work on Nitrogen in Fertilizers

To: H. A. Davis, Associate Referee on Nitrogen in Fertilizers, A.O.A.C.
 Agricultural Experiment Station
 Durham, New Hampshire
 Collaborator No.

¹ *This Journal*, 33, 1003 (1950).

Per Cent Total Nitrogen by

Sample No.	Official method	Shuey method
1 ave: ave: .
2 ave: ave: .
3 ave: ave: .
4 ave: ave: .
5 ave: ave: .

Comments:

- (1) Official method used 2.27 or 2.28 check which
 (2) Time to complete digestion , after adding acid (step 8)
 (3) Used pumice or zinc , or to prevent bumping.
 (4) Indicator used-methyl red , or mixed .

Other comments:

Signed .

RESULTS

Reports were received from twenty-one collaborators (10 industrial, 11 control laboratories) in time to be included in this report. Since samples were sent to twenty-seven collaborators there are some analyst numbers missing in Table 1. The results of the analyses expressed in terms of per cent nitrogen are presented in Table 1. The difference in results by the Shuey and the Official Method is indicated in each instance. At the bottom of each column is shown the average, the low and high result, and the difference between them for each sample. The standard error of difference and the mean difference for each sample has been calculated. For samples 1, 2, 3, and 4 the differences in favor of the Shuey method were significant at the one per cent level. In the case of sample 5 the difference was significant at the five per cent level only.

In reply to specific questions on the report sheet, twelve analysts reported using Official Method 2.27 (1) reduction with thiosulfate, two used 2.27 (2) reduction with zinc dust (both mercury catalyst), and five used 2.28 (copper catalyst). The time to complete digestion after adding acid (step 8) was reported as 30-40 minutes by eight analysts, one hour by seven analysts, one and one-half hours by two analysts, and two hours by one analyst.

Zinc was used to prevent bumping by seventeen analysts, pumice by one, and raschig glass rings by one.

Methyl red was the indicator used by twelve analysts, mixed indicator by six.

The average of the results is summarized in Table 2. Included in this table is the approximate (calculated) per cent of nitrate nitrogen in each sample, the per cent increase, average, in total nitrogen obtained by the Shuey method over the official method is also presented.

TABLE 1.—Results expressed in terms of per cent nitrogen

ANALYSE NO.	SAMPLE NO. 1		6-4-27		DIFF. B-A		SAMPLE NO. 2		13-5-13		DIFF. B-A		SAMPLE NO. 3		6-3-24		DIFF. B-A		SAMPLE NO. 4		8-16-16		DIFF. B-A		SAMPLE NO. 5		5-5-7		DIFF. B-A	
	OFFICIAL (A)	SHURY (B)	OFFICIAL (A)	SHURY (B)	OFFICIAL (A)	SHURY (B)	OFFICIAL (A)	SHURY (B)	OFFICIAL (A)	SHURY (B)	OFFICIAL (A)	SHURY (B)	OFFICIAL (A)	SHURY (B)	OFFICIAL (A)	SHURY (B)	OFFICIAL (A)	SHURY (B)	OFFICIAL (A)	SHURY (B)	OFFICIAL (A)	SHURY (B)	OFFICIAL (A)	SHURY (B)	OFFICIAL (A)	SHURY (B)	OFFICIAL (A)	SHURY (B)	OFFICIAL (A)	SHURY (B)
1	6.12	6.33	11.85	12.87	1.02	6.18	6.87	0.69	7.58	8.29	0.71	4.97	5.31	0.34	4.97	5.31	0.34	4.97	5.31	0.34	7.58	8.29	0.71	4.97	5.31	0.34	4.97	5.31	0.34	
2	6.14	6.32	12.31	12.76	0.45	6.50	6.41	-0.09	7.77	7.79	0.02	5.13	4.90	0.23	5.13	4.90	0.23	5.13	4.90	0.23	7.77	7.79	0.02	5.13	4.90	0.23	5.13	4.90	0.23	
3	6.03	6.03	12.62	12.62	—	6.24	6.26	0.02	7.89	7.89	0.00	6.24	6.26	0.02	6.24	6.26	0.02	6.24	6.26	0.02	7.89	7.89	0.00	6.24	6.26	0.02	6.24	6.26	0.02	
4	6.20	6.37	12.60	12.85	0.16	6.51	6.61	0.10	8.01	8.01	0.00	6.51	6.61	0.10	6.51	6.61	0.10	6.51	6.61	0.10	8.01	8.01	0.00	6.51	6.61	0.10	6.51	6.61	0.10	
5	6.04	6.16	12.84	12.68	0.14	6.59	6.57	-0.02	7.91	7.82	-0.09	5.16	5.08	-0.08	5.16	5.08	-0.08	5.16	5.08	-0.08	7.91	7.82	-0.09	5.16	5.08	-0.08	5.16	5.08	-0.08	
6	6.05	6.26	12.75	12.59	0.16	6.20	6.57	0.37	7.84	7.66	-0.18	5.20	5.17	-0.03	5.20	5.17	-0.03	5.20	5.17	-0.03	7.84	7.66	-0.18	5.20	5.17	-0.03	5.20	5.17	-0.03	
7	6.01	6.26	12.40	12.89	0.49	6.12	6.85	0.73	7.71	7.95	0.24	6.12	6.85	0.73	6.12	6.85	0.73	6.12	6.85	0.73	7.71	7.95	0.24	6.12	6.85	0.73	6.12	6.85	0.73	
8	6.18	6.25	12.63	12.57	-0.06	6.38	6.54	0.16	7.94	7.81	-0.13	6.38	6.54	0.16	6.38	6.54	0.16	6.38	6.54	0.16	7.94	7.81	-0.13	6.38	6.54	0.16	6.38	6.54	0.16	
9	6.32	6.27	12.15	12.86	0.71	6.46	6.62	0.16	7.99	7.86	-0.13	6.46	6.62	0.16	6.46	6.62	0.16	6.46	6.62	0.16	7.99	7.86	-0.13	6.46	6.62	0.16	6.46	6.62	0.16	
10	5.82	6.03	12.13	13.04	0.91	6.33	6.79	0.46	7.88	8.06	0.18	6.33	6.79	0.46	6.33	6.79	0.46	6.33	6.79	0.46	7.88	8.06	0.18	6.33	6.79	0.46	6.33	6.79	0.46	
11	6.19	6.32	11.82	12.74	0.92	6.57	6.80	0.23	8.05	8.36	0.31	6.57	6.80	0.23	6.57	6.80	0.23	6.57	6.80	0.23	8.05	8.36	0.31	6.57	6.80	0.23	6.57	6.80	0.23	
12	6.20	6.18	12.90	12.73	-0.17	6.68	6.68	0.00	7.95	7.96	0.01	6.68	6.68	0.00	6.68	6.68	0.00	6.68	6.68	0.00	7.95	7.96	0.01	6.68	6.68	0.00	6.68	6.68	0.00	
13	5.86	6.18	12.03	12.58	0.55	6.28	6.70	0.42	7.80	8.00	0.20	6.28	6.70	0.42	6.28	6.70	0.42	6.28	6.70	0.42	7.80	8.00	0.20	6.28	6.70	0.42	6.28	6.70	0.42	
14	5.88	6.07	12.19	12.61	0.42	6.22	6.63	0.41	7.83	7.89	0.06	6.22	6.63	0.41	6.22	6.63	0.41	6.22	6.63	0.41	7.83	7.89	0.06	6.22	6.63	0.41	6.22	6.63	0.41	
15	6.29	6.58	12.64	12.69	0.05	6.51	6.58	0.07	8.24	8.49	0.25	6.51	6.58	0.07	6.51	6.58	0.07	6.51	6.58	0.07	8.24	8.49	0.25	6.51	6.58	0.07	6.51	6.58	0.07	
19	5.85	6.22	12.67	13.14	0.47	6.54	6.85	0.31	7.87	8.00	0.13	6.54	6.85	0.31	6.54	6.85	0.31	6.54	6.85	0.31	7.87	8.00	0.13	6.54	6.85	0.31	6.54	6.85	0.31	
21	5.65	6.24	11.51	12.55	1.04	5.94	6.60	0.66	7.67	7.93	0.26	5.94	6.60	0.66	5.94	6.60	0.66	5.94	6.60	0.66	7.67	7.93	0.26	5.94	6.60	0.66	5.94	6.60	0.66	
22	6.17	6.38	12.40	12.85	0.45	6.49	6.81	0.32	8.00	8.06	0.06	6.49	6.81	0.32	6.49	6.81	0.32	6.49	6.81	0.32	8.00	8.06	0.06	6.49	6.81	0.32	6.49	6.81	0.32	
23	6.14	6.21	12.23	12.62	0.39	6.49	6.46	-0.03	7.92	7.98	0.06	6.49	6.46	-0.03	6.49	6.46	-0.03	6.49	6.46	-0.03	7.92	7.98	0.06	6.49	6.46	-0.03	6.49	6.46	-0.03	
24	6.20	6.20	12.83	12.84	0.02	6.51	6.51	0.00	7.89	7.86	-0.03	6.51	6.51	0.00	6.51	6.51	0.00	6.51	6.51	0.00	7.89	7.86	-0.03	6.51	6.51	0.00	6.51	6.51	0.00	
26	5.90	6.15	12.07	12.55	0.48	6.55	6.80	0.25	7.79	7.81	0.02	6.55	6.80	0.25	6.55	6.80	0.25	6.55	6.80	0.25	7.79	7.81	0.02	6.55	6.80	0.25	6.55	6.80	0.25	
Ave.	6.06	6.24	12.36	12.73	0.37	6.41	6.63	0.22	7.87	7.97	0.10	6.41	6.63	0.22	6.41	6.63	0.22	6.41	6.63	0.22	7.87	7.97	0.10	6.41	6.63	0.22	6.41	6.63	0.22	
Low-High	5.65-6.32	6.03-6.58	11.51-12.90	12.55-13.14		5.94-6.59	6.20-6.87		7.59-8.24	7.55-8.49		5.94-6.59	6.20-6.87		5.94-6.59	6.20-6.87		5.94-6.59	6.20-6.87		7.59-8.24	7.55-8.49		5.94-6.59	6.20-6.87		5.94-6.59	6.20-6.87		
Range	(0.67)	(0.56)	(1.39)	(0.59)		(0.65)	(0.61)		(0.66)	(0.94)		(0.65)	(0.61)		(0.65)	(0.61)		(0.65)	(0.61)		(0.66)	(0.94)		(0.65)	(0.61)		(0.65)	(0.61)		
St. error of difference			0.05362			0.02504			0.01423			0.01423			0.01423			0.01423			0.01423			0.01423			0.01423			
Mean diff.			0.1752†			0.3776†			0.2200†			0.3776†			0.3776†			0.3776†			0.3776†			0.3776†			0.3776†			

* Significant at 5% level.
† Significant at 1% level.

TABLE 2.-Average of results

SAMPLE	AVERAGE PER CENT TOTAL N BT-		APPROX. PER CENT NITRATE N PRESENT	(B)-(A)	PER CENT INCREASE BY SHUEY METHOD
	OFFICIAL (A)	SHUEY (B)			
1	6.06	6.24	2.3	0.18	2.97
2	12.36	12.73	6.2	0.37	3.07
3	6.39	6.64	6.6	0.22	3.44
4	7.87	7.97	1.9	0.10	1.27
5	5.16	5.24	0.8	0.08	1.55

COMMENTS BY COLLABORATORS

Analyst 1.-The Shuey method is time consuming but evidently captures nitrogen that would otherwise be lost.

Analyst 2.-The tributyl phosphate gave trouble by distilling and masking the end point. It gave a high blank.

Analyst 4.-The Shuey method requires more time to complete and more attention from the analyst than the official method. The distillation line is tied up during step 8. Therefore, with given equipment less work can be accomplished per day.

Analyst 8.-There doesn't seem to be much difference in the results by the two methods. The Shuey method takes a much longer time.

Analyst 9.-No defoaming agents used, heating carefully controlled. End point with mixed indicator better than with methyl red in Shuey method. Pumice better than glass beads to prevent bumping.

Analyst 10.-An excess of Devarda's alloy after step 6 can cause undue consumption of H₂SO₄. Watch out for dry distillation.

Analyst 12.-The official method using 2 gm salicylic acid is satisfactory.

The Shuey method has the following faults—the tributyl-phosphate distills over and clouds the end point, it is long, cumbersome and requires constant attention. It combines the large variation of the Devarda alloy method with the blank of the digestion. It will double the time of the analysis.

Analyst 13.-The official method apparently gives low results in mixtures of high nitrate-chloride content and some procedure should be adapted that gives the correct figure.

Analyst 19.-Trouble was experienced in getting reproducible results by the official method when chlorides and nitrates are high. When nitrate nitrogen is low as in Sample 5 the difference by the two methods is negligible.

Analyst 22.-The samples were analyzed also by 2.27 (1) and lower results obtained then by 2.27 (2).

Analyst 24.-I prefer the official method personally. Care must be used to insure solution after addition of salicylic-sulfuric acid mixture. On the whole both methods check each other and are equal in the final result.

DISCUSSION

The results shown in Table 1 indicate that most analysts obtained higher results with the Shuey method than with the present official method. This was especially true in the case of samples 1, 2, and 3 which contained the larger amounts of nitrate nitrogen. The same trend was observed when the nitrate nitrogen is present as the sodium salt (sample

3) as when it is present as the ammonium salt. The average difference was less with sample 4 but the data favoring the Shuey method is still significant. In the case of sample 5 which is low in nitrate nitrogen the difference is significant only at the 5% level. The nitrate nitrogen content being very low, little loss is to be expected in this case based on the assumption that all the loss is from nitrate nitrogen.

One point in the official method has been mentioned as being somewhat critical. This is the importance of shaking, following the addition of the salicylic acid-sulfuric acid mixture until effervescence ceases and solution is complete.

The results indicate that there is merit in the Shuey method. The major objection seems to be that it is more time consuming than the official method and the distillation equipment is tied up during the final digestion period.

A summary of the results, Table 2, indicates that the results by the Shuey method are about three per cent higher than those obtained by the present official method when applied to high nitrate-high chloride mixtures.

SUMMARY

The official method for nitrogen in fertilizers was compared, collaboratively, with a proposed Shuey method.

Results obtained by the Shuey method were in general higher than those obtained by the official method in high nitrate fertilizer mixtures.

ACKNOWLEDGMENT

As this is my first report as an Associate Referee I wish to express my appreciation to M. P. Etheredge, the former Associate Referee, for information and suggestions given me.

Certain samples were furnished by Mr. Shuey of Shuey and Co. and by Mr. Chapman of Consolidated Rendering Company. Thanks should be expressed to them, as well as to all the collaborators who took part in this work.

RECOMMENDATION*

It appears that the Shuey method has merit in the determination of nitrogen in high nitrate nitrogen-high chloride mixtures. Another collaborative trial is desirable before making a positive recommendation concerning this method. The Associate Referee will welcome any suggestions regarding this problem.

It is suggested that anyone having a specific problem he wishes discussed or considered bring it to the attention of the Associate Referee.

* For report of Subcommittee A and action of the Association, see *This Journal*, 34, 40 (1951).

REPORT ON POTASH

By O. W. FORD (Purdue University Agricultural Experiment Station, Lafayette, Indiana), *Associate Referee*

In accordance with the recommendations approved by the Association in 1949 (*This Journal*, 33,38, 1950), additional collaborative studies were made on methods for the determination of potash in fertilizers. A copy of the proposed work was sent to each chemist who had expressed a willingness to collaborate. Eighteen chemists found time to do the work and report to the Associate Referee.

SAMPLES

Ten samples of fertilizer were analysed by three methods: (a) the official A.O.A.C. method, (b) the Perrin wet digestion method, and (c) the flame photometer. All samples were ground at the Purdue laboratory in a Micro-Samplmill with the $\frac{1}{8}$ " screen, thoroughly mixed and bottled for shipment to the collaborators. The ten samples had the following composition:

1. Mixture of 10-10-10 fertilizer from 4 manufacturers.
2. Mixture of 3 analyses high in organic matter (7-8-5, 5-10-5, and 7-8-5).
3. Mixture of animal manures.
4. Mixture of urea, limestone, and potash salt.
5. Mixture of various 8-8-8 fertilizers.
6. Mixture of ammonium nitrate, potash salt and 18-6-6.
7. Mixture of sodium nitrate, Sul-Po-Mag, low grade potash salt and sodium chloride.
8. Mixture of four parts rock phosphate and one part potash salt.
9. Mixture of 4 high organic analyses (7-11-5, 7-8-5, 8-6-4 and 5-10-10).
10. Mixture of 1 part rock phosphate and 1 part potash salt.

INSTRUCTIONS TO COLLABORATORS

The survey of methods of preparation of samples for analysis by the Referee on potash, in 1949, indicated a great variety of methods was being used. Analysis of sieve tests in 1949 indicated that the most uniform results were obtained on the more finely ground samples. As this part of the work was delegated to the Referee on sampling procedures, more time can be devoted this year to further investigation of the comparison between the A.O.A.C. and C. H. Perrin's wet combustion method for potash. A need was voiced at last year's meeting for further study of these two methods on a greater variety of samples prepared for analysis by a good mechanical means, since there was a definite trend in this direction, and from any procedure where a personal factor could affect the sample.

Analysts were instructed as follows:

- (1) Prepare enough solution for 9 determinations on each sample.
- (2) Using the official method for potash, make 3 individual determinations on each sample.

TABLE 1.—*Collaborative results (average per cent potash)*

ANALYST METHOD	SAMPLE NUMBER									
	1	2	3	4	5	6	7	8	9	10
1. A.O.A.C.	10.17	5.94	3.33	19.45	8.81	18.66	11.08	11.46	8.22	27.90
Perrin	9.88	5.86	3.25	18.37 ^a 20.30 ^b	8.36 ^a 8.64 ^b	20.07 ^b	10.62 ^a 13.66 ^b	11.34	8.22	27.75
2. A.O.A.C.	9.97	5.67	2.81	19.25	8.74	18.47	10.73	10.91	8.07	27.55
Perrin	9.82	5.55	3.13	19.12	8.81	18.29	10.59	10.94	8.07	27.81
3. A.O.A.C.	9.93	5.74	3.13	19.67	8.71	18.74	10.90	11.13	8.15	27.87
Perrin	9.82	5.67	3.03	19.49	8.73	18.48	10.71 ^a	11.17	8.19	27.90
4. A.O.A.C.	9.73	5.56	2.98	19.43	8.66	17.14	10.59	10.95	7.60	27.39
Perrin	9.37	5.15	2.91	19.41	8.57	18.01	10.57	11.21	7.78	27.79
5. A.O.A.C.	8.81	5.38	—	19.31	—	18.33	—	—	—	28.04
Perrin	9.91	5.22	—	19.16	—	17.90	—	—	—	27.58
6. A.O.A.C.	9.85	5.74	3.35	19.46	8.82	18.50	10.85	11.13	8.05	27.70
Perrin	9.80	5.62	—	19.37	8.69	18.29	10.86	11.33	7.78	27.85
7. A.O.A.C.	10.05	5.73	3.23	19.72	8.44	18.63	11.31	11.48	7.83	27.79
Perrin	10.45	5.56	3.23	19.80	8.45	18.53	11.13	11.29	8.20	28.02
8. A.O.A.C.	9.98	5.75	3.13	19.80	8.78	18.44	10.82	11.51	8.27	28.38
Perrin	10.04	5.86	3.38	19.79	9.18	18.73	11.33 ^b	11.81	8.51	28.90
Flame	10.15	5.75	3.05	19.68	8.80	18.40	11.30 ^d	11.60	8.20	28.20
9. A.O.A.C.	9.88	5.34	2.95	19.20	8.56	18.07	10.45	10.96	7.88	27.83
Perrin	9.91	5.65	2.93	20.41	8.61	18.30	16.78 ^b	11.16	8.02	27.61
10. A.O.A.C.	9.52	5.07	3.24	19.46	8.47	18.42	10.95	10.87	7.53	27.24
Perrin	10.07	5.73	3.10	19.15	8.81	18.22	10.70	11.02	8.02	27.56
11. A.O.A.C.	10.04	5.51	3.08	19.59	8.75	18.30	10.98	11.16	8.22	27.57
Perrin	10.05	5.71	3.28	19.69	8.39	18.62	10.92	11.32	7.23	27.23
12. A.O.A.C.	10.01	5.78	3.31	19.40	8.97	18.56	10.82	11.01	8.25	27.64
Perrin	10.02	5.79	3.38	19.51	9.03	18.49	10.84	11.07	8.17	27.63
13. A.O.A.C.	10.00	5.55	3.15	19.44	8.84	18.58	10.79	11.04	—	28.35
Perrin	9.96	5.60	3.01	19.32	8.67	18.48	10.63 ^a	11.44	—	27.92
Flame	9.90	5.70	3.10	19.20	8.60	18.40	1.090	11.50	—	28.00
14. A.O.A.C.	10.05	5.71	3.28	19.28	8.73	18.69	11.03	11.17	8.19	27.93
Perrin	9.85	5.58	3.10	19.44	8.69	18.58	11.33	11.02	8.16	27.79
Flame	10.07	5.74	3.12	19.61	8.81	19.03	11.03	11.07	8.22	28.20
15. A.O.A.C.	9.94	5.66	—	—	—	18.38	—	10.76	8.08	—
Perrin	9.84	5.52	—	—	—	18.27	—	10.79	7.88	—
16. A.O.A.C.	10.04	5.87	3.35	19.46	8.64	18.51	10.79	11.27	8.33	27.89
Perrin	10.52	5.94	3.28	20.22	8.86	18.91	11.25 ^a 18.53 ^b	11.50	8.35	29.01
17. A.O.A.C.	9.99	5.53	3.31	19.63	8.82	18.75	11.65	10.93	7.91	27.52
Perrin	9.82	5.46	3.00	19.15	8.43	17.76	10.59	10.58	7.69	27.14
18. Flame	8.25	5.25	3.05	17.50	7.30	16.75	9.25	10.00	7.20	27.50
19. ^g Flame	9.93	5.58	3.05	19.83	8.69	18.74	11.66	11.22	7.79	28.03
19. ^h Flame	9.83	5.60	2.89	19.47	8.51	18.66	11.63	11.34	7.78	28.32

^a Washed with ammonium chloride.

^b Not washed with ammonium chloride.

^c Not corrected for sodium.

^e Solution prepared by the A.O.A.C. procedure.

^f Solution prepared by the A.O.A.C. procedure but ammonium oxalate omitted.

(3) Using the C. H. Perrin wet combustion method (copy of details enclosed), make 3 individual determinations on each sample.

(4) If a flame photometer is available, make 3 different readings on each sample.

Please list any comments or criticisms.

The samples sent to you have been ground through a Micro-Samplmill and should be analyzed as received.

The approximate potash content of the samples is as follows:

1. 0-0-10	6. 0-0-18
2. 0-0-5	7. 0-0-16
3. 0-0-1	8. 0-0-13
4. 0-0-25	9. 0-0-6
5. 0-0-8	10. 0-0-25

It should be understood that 95% ethyl alcohol or 95% formula 30 alcohol and the corresponding acid-alcohol will be used for the potash determinations.

RESULTS AND DISCUSSION

In general, the results of the three methods showed fairly good agreement (Table 1). As several of the collaborators had reported that sample No. 7 by the Perrin method should be washed with ammonium chloride if correct values were to be obtained, it was thought advisable to determine what amounts of sodium and magnesium would affect the potash determination. Accordingly, three potash solutions containing the equivalent of

TABLE 2.-*Ejects of sodium and magnesium ions on potash analysis*

METHOD	PER CENT POTASH FOUND IN-			
	ALIQUOT	SOLUTION A (6.00% K ₂ O)	SOLUTION B (12.00% K ₂ O)	SOLUTION C (18.00% K ₂ O)
A.O.A.C.	5	6.05	12.10	18.10
A.O.A.C.	10	6.08	12.13	18.10
A.O.A.C.	25	6.04	12.06	18.05
Perrin	5	10.50	15.75	34.00
Perrin	10	10.75	15.95	34.20
Perrin	25	10.99	15.12	34.24
Perrin (Modified*)	5	6.10	12.10	18.10
Perrin (Modified*)	10	6.05	12.15	18.15
Perrin (Modified*)	25	6.08	12.09	18.09
Flame		6.58	12.95	19.45
Flame (Correctedt)		6.01	12.00	18.00

* Washed with NH₄Cl.

† Sodium added to standard to give same Na:K ratio as sample.
Solution A contained 0.25 g Mg(NO₃)₂ and 2.0 g NaCl per 250 ml.
Solution B contained 0.25 g Mg(NO₃)₂ and 2.0 g NaCl per 250 ml.
Solution C contained 0.25 g Mg(NO₃)₂ and 4.0 g NaCl per 250 ml.

6, 12, and 18% potash per 25 ml were made (samples A, B, and C, Table 2). To samples A and B, $\frac{1}{4}$ gram of magnesium nitrate and 2 grams of NaCl were added, and to sample C, $\frac{1}{4}$ gram of magnesium nitrate and 4 grams of sodium chloride, Potash determinations were then made on 5, 10, and 25 ml portions of each solution by the A.O.A.C. and Perrin methods. No trouble was encountered with the A.O.A.C. method, as the magnesium salt and excess sodium salts were removed in the ammonium chloride and alcohol washes; but as little as 5 ml of each solution gave high results by the Perrin method unless the precipitates were given the

ammonium-chloride wash for removal of magnesium (see Table 2). Sodium did not affect the results by the Perrin method but did affect the flame photometer values. When a correction was made by adding sodium to the standard, the theoretical values of 6, 12, and 18% were obtained. Excluding sample No.7, the average differences between the A.O.A.C. and Perrin analyses was less than 0.1% potash. This agreed well with the results obtained last year. It would seem unfair to include the results of sample No.7 in the average, as not all chemists indicated whether or not they had used the Lindo Gladding wash of ammonium chloride.

Likewise, the results reported by the use of a flame photometer were not averaged, since it was evident that in several cases the chemist had not corrected his results for sodium interference. It would appear from a study of these results that with the proper standards, made to correct for sodium content, good reproducible results can be obtained by the use of a flame photometer.

LIST OF COLLABORATORS

- (1) Austin, W. R., and Buford, Madelane, Armour Fertilizer Works, Nashville, Tenn.
- (2) Batton, H. C., and Craver, B. H., Swift & Company, Buell, Va.
- (3) Sale, H. E., and Blackwell, A. T., The Davison Chemical Corporation, Baltimore 3, Md.
- (4) Lang, P. A., and Mudrak, A., The American Agricultural Chemical Company, Carteret, N. J.
- (5) Caldwell, Paul, Darling & Company, Chicago, Ill.
- (6) Etheredge, M. P., Mississippi State Chemical Laboratory, State College, Miss.
- (7) Geagley, W. C., O'Meara, P., and Thorpe, V. A., Michigan Department of Agriculture, Lansing, Mich.
- (8) Schall, E. D., Rabourn, W. J., and Hagelberg, R. R., Purdue University, Agricultural Experiment Station, Lafayette, Ind.
- (9) Kocaba, H., and Fisher, H. J., The Connecticut Agricultural Experiment Station, New Haven 4, Conn.
- (10) Koehler, L. A., State Laboratories Department, Bismarck, N. Dak.
- (11) Mowery, G. C., Randall, E. S., and Holeman, E. H., State of Tennessee Department of Agriculture, Nashville, Tenn.
- (12) Moxon, H. L., and Powell, R. O., Virginia-Carolina Chemical Corporation, Fertilizer Division Laboratory, Richmond, Va.
- (13) Perrin, C. H., Canada Packers Limited, Toronto, Canada.
- (14) Randle, S. B., Rutgers University, New Jersey Agricultural Experiment Station, New Brunswick, N. J.
- (15) Smith, W. A., Smith-Douglass Company, Inc., Streator, Ill.
- (16) Smith, R. M., State of Florida Agricultural Department, Chemical Division, Tallahassee, Fla.
- (17) Koch, R. C., Swift & Company, Hammond, Ind.
- (18) Bowman, D. R., University Farm, University of Tennessee, Knoxville, Tenn.
- (19) Smith, G. R., Chemistry, Soils and Fertilizer Services, Department of Agriculture and Marketing, Truro, Nova Scotia.

COMMENTS OF COLLABORATORS

(1) You will note on some of these samples we were able to get very nice agreement between the official A.O.A.C. procedure and the proposed Perrin method. We really believe the latter has wonderful possibilities when the kinks are ironed out, particularly for use in quick control of factory control where speed is urgent. We sure do hope this method will be studied another year, and suggest that a clause be inserted requiring the use of Lindo Gladding wash followed by regular alcohol to insure its removal. With this one point taken care of it may prove satisfactory we think, but several steps in procedure may be discussed in the A.O.A.C. Meeting this Fall at Washington.

From our observation we think that where regular high grade muriates are used it may be okay as is, but there will be cases where sulphate potash magnesia or other magnesium salts are present which probably is true on some of these samples judging from some of our results where we decided to try to use Lindo Gladding to see what happened. Low potash salts like manure salt high in sodium may cause a little trouble, likewise iron or alumina impurities may be even lesser sources of error for all of which a Lindo Gladding wash would be necessary.

If there are any of these results which you think should be discarded, you have our permission to do so. We simply gave you all we did on certain ones where we ran into trouble obtaining agreement.

Sample #7 showed evidence of magnesium salt and should have an ammonium chloride wash.

(2) We had considerable trouble with sample #6. We ran determinations on three sets of digestions. There was wide variation in the A.O.A.C. results but excellent agreement on the Perrin determinations. Results were not selected but only the results of one single digestion were reported.

(3) We would call attention to the fact that by the Perrin method an insoluble residue was found-this was soluble in NH.CI without washing with NH.CI, the results were erratic and varied as much as two to three per cent. This insoluble residue was identified as magnesium and apparently all that is necessary to make the Perrin method applicable to compounds containing magnesium is to make an NH.CI wash.

(6) We have bought a Beckman Flame Photometer, but having had little experience with it will not attempt to report any results with it this year.

(7) In using 50 ml aliquots, larger samples in the Perrin method are contaminated with large amounts of white salts in which case an NH.CI wash should be used for best results.

(8) Sample #7 contained an abnormal amount of sodium salts as well as magnesium. Results reported by flame for this sample should be corrected for sodium. Potash results by the Perrin method for sample #7 should have had an NH.CI wash to remove the magnesium.

(9) The results reported on sample #7 are not a typographical error. The approximately 6% difference between the two methods was what our analyst actually found. We did not make any qualitative tests on this or any other sample to see if it contained ammonium salts, but in looking over the text of the Perrin method, I cannot help but wonder whether the aqua regia outlined would be sufficient to remove all the ammonium salts if they were present in substantial proportion. If the ammonium salts were not always completely removed this could explain the lack of agreement between our results by the two methods on samples 4 and 7.

(12) Our conclusions are that these two methods give comparable results and if only one or two samples are to be run, the Perrin method is more rapid. However, in routine work where 100 or more determinations are made each day, this procedure is not as rapid as the present official method.

(13) Sample #7 is the first sample I have encountered that required the ammonium chloride wash in the new method. We were pleased to note the good results obtained with the flame photometer.

(14) Flame results made on a Barclay Flame photometer. Six determinations were made on sample #7 by the Perrin method since a white precipitate formed in four instances and remained along with the K_2PtCl_6 even after filtration.

The precipitate did not dissolve in alcohol but did in hot water. The results on these four determinations were entirely out of line and are not included in the report. The two determinations reported did not check very well. Has this condition been reported for sample #7 by any other collaborator?

(15) I have done considerable work with Perrin's method this past year and I believe it has many advantages. In the above results, it was necessary to allow for insoluble matter in the A.O.A.C. method but not in the Perrin method.

(16) Sample #7 gave the most difficulty. There was some insoluble matter insoluble in alcohol but soluble in the Gladding wash. When washed with the Gladding wash, the results were more in keeping with those obtained by the official method. Regarding the Perrin method, as to the results of this year's work, it does not seem sufficiently foolproof for general application. It is unsuited for routine analysis. Using official method by staggering sets one man can run 40 samples daily by the Perrin, 15 samples would be the limit.

(17) Except for samples #6 and #7 the Perrin method has given results in good agreement with the A.O.A.C.

(18) Flame values for samples 1, 5, and 7 show little change from the nitric perchloric treatment when prepared by the A.O.A.C. method of preparation. Apparently the amount of free acidity does affect the potassium values when the flame photometer is used in measuring it.

(19) When flame photometer is used in measuring the potassium, the presence of a high concentration of $(NH_4)_2C_2O_4$ in some ways interfere with a steady rate of atomization of the potassium.

RECOMMENDATION"

It is recommended that the present A.O.A.C. method, and the modified Perrin and flame photometer methods be compared, with further collaborative samples containing magnesium, sodium, and other ions which might cause interference in analysis.

ACKNOWLEDGMENT

The thanks of the Associate Referee are extended to the many collaborators for their cooperation and comments, and to F. W. Quackenbush for suggestions and criticisms in the development of this report.

.. For report of Subcommittee A and action of the Association, see *This Journal*, 34,4] (1951).

REPORT ON SULFUR IN MIXED FERTILIZERS

By GORDON HART* and N. J. HALBROOK (Florida Agricultural Dept., Tallahassee, Fla.)

The investigation was confined to work on methods for free sulfur.

1. Checking the accuracy of the present method, Free Sulfur (A.O.A.C.) 2.63.
2. Boiling with 1 to 10 HCl and extracting.
3. Digesting with cold 1-2 HNO₃ and extracting.
4. Dissolving in sodium sulfite and titrating.

It was found that the present first action method, 2.63, did not recover all the sulfur when flowers of sulfur was the source of free sulfur.

Method 2 (Dr. Carpenter); Boiling sample 15 minutes with 1-10 HCl, washing with hot water on filter, air dry and extract with carbon disulfide. (When flowers of sulfur was the source of free sulfur the boiling did not convert the sulfur to soluble form and recovery was incomplete.)

Method 3, digesting with cold 1-2 HNO₃ for five minutes, washing and extracting as above, gave good recovery, but was not tried on flowers of sulfur.

Method 4, consisting briefly of boiling 30 minutes with disodiumphosphate, washing and transferring the residue to flask and boiling with sodium sulfite to convert free sulfur to sodium thiosulfate, and titrating with potassium iodate. This method gave complete recovery of all free sulfur. However, it is not sufficiently worked out for detailed publication or collaboration.

RECOMMENDATIONS†

It is recommended-

- (1) That the method for free sulfur be held at first action.
- (2) That the proposed method 2 be tried out, exploding in bomb instead of carbon disulfide extraction.
- (3) That the proposed method 4 reported be further studied, and if possible studied collaboratively.

No reports were given on magnesium and manganese; acid- and base-forming quality; copper and zinc; boron; or inert materials.

The contributed paper, "A Method for Determining Total Nitrogen in Fertilizers Containing Chlorides-Applicable in the Presence of Organic Matter, Cyanamid, or Urea," by Philip Shuey, has been published in *This Journal*, 33,1003 (1950).

* Associate Referee. All work done by Halbroom.

† For report of Subcommittee A and action of the Association, see *This Journal*, 34,41 (1951).

REPORT ON ECONOMIC POISONS

By J. J. T. GRAHAM (Insecticide Division, Livestock Branch, P.M.A. Department Agriculture, Washington, D. C.), *Referee*

At last year's meeting the Referee requested volunteers to act as Associate Referees, and the following chemists agreed to act in that capacity:

- A. B. Heagy, Maryland Inspection & Regulatory Service, College Park, Maryland
- J. D. Patterson, State Department of Agriculture, Salem, Oregon
- J. B. LaClair, State Department of Agriculture, Sacramento, California
- Herbert A. Rooney, State Department of Agriculture, Sacramento, California
- C. V. Bowen, F. I. Edwards, E. E. Fleck, S. A. Hall, all of Division of Insecticide Investigations, Bureau of Entomology and Plant Quarantine, United States Department of Agriculture, Beltsville, Maryland.
- T. H. Harris, W. A. Aflens, R. L. Caswell, all of Insecticide Division, Livestock Branch, Production and Marketing Administration, United States Department of Agriculture, Beltsville, Maryland.

The Association appreciates the work of the Associate Referees, and their reports need no comments by the Referee.

In previous reports the Referee has mentioned a collaborative study of methods for determination of pyrethrins in pyrethrum powder that was carried out under direction of the Imperial Institute of Great Britain. A report of this work consisting of 63 pages was issued in April of this year. Forty-two analysts in widely separated parts of the world took part in the work, and the Mercury Reduction, Seil, and Ripert Methods were studied.

The mercury reduction method used was a modification of the official A.O.A.C. method. The extraction solvent was changed from petroleum ether to normal hexane. Hydrochloric acid was used to neutralize and acidify the saponified aqueous solution of the pyrethrins. This eliminated the necessity of filtering from barium sulfate. In the determination of pyrethrin II the neutralization of the acid aqueous residue and washings from the determination of pyrethrin I and extraction with chloroform was omitted. With these exceptions, the method used in this study was similar to the official procedure. The Seil method was revised under the direction of H. A. Seil, and the details of the Ripert method were furnished by Miss S. Gerhardstein of Dr. Ripert's laboratory.

The Referee will not attempt to comment on the voluminous report of the Consultative Committee on Materials of Vegetable Origin, of the Imperial Institute; however, it appears appropriate to quote the portions of the conclusions that refer to the results obtained by the three methods.

"The investigation has shown that the Ripert method gives less concordant results than either the Seil or the Mercury Reduction method and for this reason is dismissed from further consideration.

"Further, the evidence obtained is such that it is impossible to recommend that either the Seil or the Mercury Reduction method should be adopted preferentially

as a standard method for the analysis of pyrethrum flowers. It is true that for total pyrethrins the standard error by the Seil method of a single determination for comparison between laboratories is less than that by the Mercury Reduction method, but this cannot be regarded as significant and, were the experiment to be repeated, it is quite possible that the order of the standard errors might be reversed.

"An examination of the collaborators' remarks revealed that three definitely preferred the Seil method and three the Mercury Reduction method. In addition to these, six found some definite advantage in the Seil method either as regards time or manipulation of the method, while four stated a similar advantage for the Mercury Reduction method.

"The investigation has demonstrated the limits of concordance which can be expected in the assessment of the pyrethrin content of the flowers and, consequently, has clearly defined the practical limits to which flowers can be bought and sold with reasonable chance of agreement between buyer and seller. Whether the Seil or the Mercury Reduction method is used a difference of 0.3 between the determinations as carried out by two laboratories should not be regarded as significant for flowers containing between 1 and 2 per cent total pyrethrins. This statement assumes the complete absence of errors in sampling a consignment of flowers which this investigation was designed to eliminate.

"The collaborative work has shown very clearly that it is essential that the same method of analysis be stipulated in a contract between a buyer and a seller of the flowers."

The Referee has recently received a letter from V. A. Beckley, Scientific Adviser to the Kenya Pyrethrum Board, with reference to an apparent defect in the Mercury Reduction Method. Mr. Beckley states that filtration of the barium sulfate that is formed by acidification with sulfuric acid, causes low results for pyrethrin I. He states he has found that results obtained by following the details of the official method exactly, are substantially lower than when the precipitate is allowed to remain, or if hydrochloric acid is used for acidification. He has also found that extracts of the residue on the filter give qualitative tests for pyrethrin I, and the investigation is to be continued on a quantitative basis.

This year, for the first time, methods for analysis of products containing chlordane, quaternary ammonium disinfectants, and coal tar disinfectants in economic poisons were studied under the direction of Associate Referees. Other products, mentioned last year as subjects for study, include aerosol insecticides, piperonyl butoxide, piperonyl cyclonene, and zineb (zinc ethylene bis dithiocarbamate). Among new economic poisons for which methods will be required are allethrin, aldrin, dieldrin, and warfarin.

In view of the numerous subjects for study, the Referee again requests volunteers to act as Associate Referees on economic poisons.

RECOMMENDATIONS.

It is recommended-

(1) That an Associate Referee be appointed to study methods for determination of pyrethrins, with special attention to the mercury reduction method.

• For report of Subcommittee A and action of the Association, see *This Journal*, 34, 42 (1951).

(2) That an Associate Referee be appointed to study methods for determination of allethrin.

(3) That an Associate Referee be appointed to study methods for determination of piperonyl butoxide.

The Referee concurs in the following recommendations of the Associate Referees:

(4) That collaborative study be made of the electrometric titration method, and the adsorption indicator method (Fajan's method) for halides in quaternary ammonium salts.

(5) That collaborative study be made of the ferricyanide method to establish its applicability to determination of quaternary ammonium compounds in disinfectants.

(6) That the colorimetric methods be further studied to establish their applicability to relatively dilute solutions of quaternary ammonium compounds in commercial preparations.

(7) That the Davidow, and the Harris methods for determination of chlordane be further studied.

(8) That the polarographic and the titration methods for analysis of parathion be subjected to collaborative study, and that a more acceptable indicator be sought for the titration method.

(9) That study of methods for determination of alpha naphthyl thiourea in rodenticides be discontinued, and the study of methods of analysis for other rodenticides be continued.

(10) That the Elmore method for the determination of organic thiocyanate nitrogen in livestock or fly sprays be revised as recommended in the report of the Associate Referee, and adopted first action.

(11) That the first action method for the determination of 2,4-dichlorophenoxyacetic acid, **5.129** (p. 77), with added note, be adopted as official.

(12) That study of methods for determination of 2,4-Dichlorophenoxyacetic acid in herbicides be continued, paying special attention to products containing small quantities of the ingredient, and to the ester type of compounds.

(13) That the method for determination of total chlorine in liquid herbicides containing 2,4-D, 2,4,5-T, or mixtures of both in presence of oils and emulsifiers, by a modified Parr bomb procedure, be subjected to collaborative study.

(14) That the method for determination of potassium cyanate in herbicides be subjected to collaborative study.

(15) That the method for determination of tetraethyl pyrophosphate adopted at the 1949 meeting as first action, be now made official.

(16) That the modified partition chromatographic method for determination of the gamma isomer in technical benzene hexachloride, and in wettable powders and insecticidal dust formulations, 7th Ed. *Book of Methods*, **5.149-5.153**, incl., be adopted as an official method.

(17) That the infrared spectrophotometer method for determination of the gamma isomer in technical benzene hexachloride, in the 7th Edition of the Book of Methods, 5.154-5.157, incl., be adopted as an official method.

(18) That work on phenolic disinfectants be continued.

REPORT ON RODENTICIDES

By J. B. LA CLAIR (California State Department of Agriculture, Bureau of Chemistry, Sacramento 14, California), *Associate Referee*

The 1949 collaborative determination of alpha naphthyl thiourea from total nitrogen indicated a simple yet reliable method for determining this compound in the technical material and in formulations.

This year's collaborative study was a duplication of the work done in 1949, with the following exceptions: The technical alpha naphthyl thiourea used in the samples was from a different source, a higher percentage of alpha naphthyl thiourea was used in the prepared samples, and the extraction procedure for greasy materials containing alpha naphthyl thiourea was revised, incorporating the changes suggested by A. B. Heagy and J. E. Schueler. (*This Journal*, 33, 759 (1950)).

Three samples were submitted to collaborators for analysis. Sample No. 1 was a technical grade alpha naphthyl thiourea analyzed for total nitrogen by one of the methods described under sections 2.24, 2.25, or 2.26 of the 6th Edition, *Methods of Analysis*. The percentage of total nitrogen determined multiplied by the factor 7.215 was reported as the percentage of alpha naphthyl thiourea. Sample No. 2 contained approximately 10% technical alpha naphthyl thiourea mixed with diatomaceous earth as a diluent. This sample was extracted 8-10 hours with acetone in a Soxhlet apparatus. After evaporating off the acetone the residue was analyzed for alpha naphthyl thiourea by total nitrogen. Sample No. 3 was a prepared bait containing 5% technical alpha naphthyl thiourea mixed with soya meal, fish meal, ground wheat, bran and animal fat. This sample was extracted one hour with petroleum ether in a Soxhlet apparatus. After withdrawing and discarding the petroleum ether, the sample was extracted with acetone, etc. as in the regular procedure.

COMMENTS OF COLLABORATOR JAMES B. DE WITT

Three different extraction procedures were used with samples 2 and 3. With sample No. 2, extraction in a Soxhlet apparatus, as prescribed in the method, gave higher results than were obtained by extraction in a Bailey-Walker apparatus. No significant changes in percentage alpha naphthyl thiourea found resulted when the extraction time in the Bailey-Walker apparatus was increased from 2 hours to 8 hours. With sample No. 3, an extraction period of 2 hours in the Bailey-Walker apparatus appeared inadequate, while extraction for 8 hours in this apparatus gave approximately the same results as were obtained by use of the Soxhlet apparatus.

DISCUSSION

From the analyses of sample No.1 (technical alpha naphthyl thiourea) it is apparent that any error in determining nitrogen on a 0.2 gram sample will be greatly magnified when the percentage of nitrogen is calculated to per cent alpha naphthyl thiourea. By using as large a sample weight of technical alpha naphthyl thiourea as is conveniently possible more consistent results should be obtained.

The data presented by collaborator James B. De Witt (see Table 1) clearly proves the necessity of acetone extracting samples for total period of 8 hours. These data show a comparison in extraction efficiency of the Soxhlet and Bailey-Walker extraction apparatus for these types of material.

TABLE 1.-*Results of collaborative analyses of alpha naphthyl thiourea sample 8*

COLLABORATING CHEMIST	SAMPLE No.1 PER CENT ALPHA NAPHTHYL THIOUREA	SAMPLE No.2 PER CENT ALPHA NAPHTHYL THIOUREA	SAMPLE No.3 PER CENT ALPHA NAPHTHYL THIOUREA
S. J. Few, Mississippi State Chemical Laboratory, State College, Mississippi	97.40	10.53	5.23
James B. De Witt, United States Dept. of Interior, Fish and Wildlife Service, Patuxent Research Refuge, Laurel, Maryland	94.73	10.68	4.14
	94.88	10.39	4.49
	94.95	10.25	4.76
	94.81		
	96.18	Av. 10.44"	Av. 4.46"
	Av. 95.31	9.09	3.39
		9.74	3.39
		10.03	4.05
		Av. 9.62 ^b	Av. 3.61 ^b
		9.16	4.42
	9.88	4.42	
	10.03	4.76	
	Av. 9.69	Av. 4.53	
J. B. La Clair, California State Dept. of Agriculture, Bureau of Chemistry Sacramento, California	95.96	10.16	4.69
	95.45	10.18	4.70
	95.45	10.17	4.73
	Av. 95.62	Av. 10.17	Av. 4.71
Averages, not including (b) and (c)	96.11	10.38	4.80

^a Extracted 10 hours with acetone in Soxhlet extraction apparatus.

^b Extracted 2 hours with acetone in a Bailey-Walker extraction apparatus.

" Extracted 8 hours with acetone in a Bailey-Walker extraction apparatus.

NOTE.-In all determinations on Sample No.3 the sample was extracted one hour with petroleum ether prior to the acetone extraction.

	<i>SampZe</i> <i>No. 2</i>	<i>Sample</i> <i>No. 9</i>
Percent by wt. of tech. alpha naphthyl thiourea in sample	10.65	5.00
Percent alpha naphthyl thiourea (calculated) ^t	10.24	4.81
Percent alpha naphthyl thiourea (determined)	10.38	4.80

^t Assuming the technical alpha naphthyl thiourea contained 96.11% alpha naphthyl thiourea.

The one-hour petroleum ether extraction of greasy materials containing alpha naphthyl thiourea is apparently sufficient to remove the bulk of fat and greases, as no trouble has been encountered from excessive foaming at the start of the Kjeldahl digestion. This extraction also reduces the possibility of extracting with acetone any nitrogen containing compounds other than alpha naphthyl thiourea which might be present in a prepared bait.

The close agreement of analytical results obtained in 1949 was not achieved this year, but they are close enough to prove the value of the method.

RECOMMENDATIONS-

It is recommended-

(1) That work on the determination of alpha naphthyl thiourea from nitrogen be discontinued. "Antu" is being replaced by more efficient rodenticides.

(2) That the method for determining alpha naphthyl thiourea from total nitrogen continue to be classified as "First Action" for the time being.

(3) That work be continued on developing methods of analysis for some of the newer rodenticides.

REPORT ON CHLORDANE AND TOXAPHENE

By THOMAS H. HARRIS (Insecticide Division, Livestock Branch, Production and Marketing Administration, U. S. Department of Agriculture, Beltsville, Maryland), *Associate Referee*

Because there is as yet no known specific method for the determination of toxaphene, and because of lack of time for original study of this problem, the Associate Referee was unable to give consideration to determination of this ingredient in insecticides. Therefore, his attention was directed toward the determination of chlordane in experimental and commercial formulations. In this work two methods, one a spectrophoto-

• For report of Subcommittee A and action of the Association, see *This Journal*, 34,42 (1951).

metric method developed by Davidow¹ and the other a spectrophotometric method which was devised by the Associate Referee,² were investigated. This report briefly describes these methods, summarizes the experience of the Associate Referee in applying them to formulations, and recommends a future program of work.

(1) *Davidow Method.*-This method was devised for microgram quantities of chlordane in plant and animal materials and is based upon the reaction of some of the insecticidally active components of technical chlordane with diethanolamine and methyl alcoholic potassium hydroxide which yields a red-colored solution. The optical density of the reaction mixture is measured in a spectrophotometer at 521 m μ .

(2) *Harris Method.*-This method is likewise a spectrophotometric method and depends upon the production of a violet-colored solution by heating technical chlordane with naphthalene, methyl alcoholic potassium hydroxide, and dry pyridine. The absorption maximum is located at 404 m μ .

The Davidow and Harris methods apparently measure the same active components of technical chlordane and possess approximately the same degree of specificity and sensitivity. The Associate Referee's experience in applying these methods to experimental and commercial formulations is summarized below.

(1) Both methods give reasonably good results on solutions of chlordane in petroleum distillates even in the presence of other chlorinated insecticides, i.e., DDT, BHC, toxaphene, dieldrin, and aldrin.

(2) Both methods in their present state of development yield erratic results on many dust formulations.

(3) The reproducibility of each of the methods must be improved in order to obtain consistently good results.

(4) Each of the methods is subject to a number of interfering substances but it has been possible, in many instances, to alleviate this difficulty by suitable sample preparation or purification.

(5) The accuracy of the results obtained with both methods depends to some extent upon the uniformity of different production batches of technical chlordane. This is due to the fact that the molecular extinction coefficients of the various components of technical chlordane are different.

It is believed that both of these methods can be developed sufficiently to warrant a collaborative study during the next year. The following have indicated their willingness to collaborate on this problem:

(1) Dr. Allen B. Lemmon, Chief, Bureau of Chemistry Department of Agriculture, 1125 10th Street, Sacramento 14, California.

(2) Dr. J. F. Fudge, State Chemist, Department of Chemistry, Texas A. and M. College, College Station, Texas.

(3) Dr. Bernard Davidow, Division of Pharmacology, Food and Drug Administration, Washington, D. C.

¹ B. L. Davidow: *This Journal*, **33**, 130,886 (1950).

² Unpublished.

(4) Mr. Robert L. Caswell, Insecticide Division, Livestock Branch, P.M.A., U. S. Department of Agriculture, Washington, D. C.

It is recommended* that the Davidow and Harris methods be further studied with the view toward adapting them to various formulations, and subjecting them to collaborative study.

REPORT ON HERBICIDES

By A. B. HEAGY (Maryland Inspection and Regulatory Service,
College Park, Md.), *Associate Referee*

RECOMMENDATIONS†

It is recommended-

(1) That method **5.129(a)&(b)** for the determination of 2,4-dichlorophenoxyacetic acid, which was adopted as official, first action, in 1949, be now adopted as official with the addition of the following note:

(b) If the material is highly acidic, transfer sample to a 250 ml beaker, add 50 ml of water, neutralize with 10% NaOH and add 5 ml in excess. Proceed as directed in (b), beginning "warm and stir 15 min."

(2) That method **5.129(c)** for the determination of salts of 2,4-dichlorophenoxyacetic acid, which was adopted as official first action in 1949, be now adopted as official.

(3) That method No. **23A**,¹ for the determination of esters of 2,4-dichlorophenoxyacetic acid (revised) be subjected to further study.

(4) That method No. **23B**,¹ for the determination of esters of 2,4-dichlorophenoxyacetic acid be dropped.

(5) That the method for the determination of total chlorine in liquid herbicides containing 2,4-D, 2,4,5-T, or mixtures of both in the presence of oils and emulsifiers by a modified Parr bomb procedure, be subjected to collaborative study.

(6) That the method for the detection of trace quantities of 2,4-D, 2,4,5-T, and related compounds in insecticide mixtures, be subjected to collaborative study.

(7) That the method for the determination of potassium cyanate in herbicides, be subjected to collaborative study.

* For report of Subcommittee A and action of the Association, see *This Journal*, 34, 42 (1951).

† For report of Subcommittee A and action of the Association, see *This Journal*, 34, 42 (1951).

¹ *This Journal*, 33, 767 (1950).

REPORT ON QUATERNARY AMMONIUM COMPOUNDS

By R. L. CASWELL (Insecticide Division, Livestock Branch, Production and Marketing Administration, U. S. Department of Agriculture, Beltsville, Maryland), *Associate Referee*

Because various quaternary ammonium compounds are being used in the sanitation and disinfecting fields, it is desirable to develop reliable methods for the analysis of these products. This report is concerned with a survey and preliminary investigation of methods that may be conveniently used for the analysis of these commercial preparations.

Most of the compounds in use are high molecular weight quaternary ammonium chlorides or bromides, for example, para diisobutyl phenoxy ethoxy ethyl dimethyl benzyl ammonium chloride monohydrate and cetyl trimethyl ammonium bromide. The total nitrogen may be determined readily by the Kjeldahl-Gunning-Arnold Method (*Methods of Analysis*, 6th Ed., paragraph 2.26, p. 27) and the total halide may be determined by a modification of one of the standard procedures.

The electrometric titration method and the absorption indicator method have been found to be the most convenient. The following procedures were studied:

CHLORIDE IN QUATERNARY AMMONIUM COMPOUNDS
ELECTROMETRIC TITRATION METHOD

Transfer a sample containing from 30-35 mg of chlorine to a 600 ml beaker, dilute to 200 ml, and add 5 ml of (1+1) nitric acid. Add just sufficient acetone to dissolve the precipitate that is formed and titrate the chloride with an electrometric titrimeter (Fisher Titrimeter or the equivalent).

Calculate the percentage of chloride (1 ml of 0.1 *N* silver nitrate is equivalent to 0.0035457 g Cl) and the equivalent percentage of quaternary ammonium salt.

ABSORPTION INDICATOR METHOD (1,2)

(a) *Bromothymol blue indicator*.-1 g bromothymol blue in 500 ml alcohol (50% by volume).

(b) *Dichlorofluorescein soln*.-0.1%.-100 mg dichlorofluorescein in 100 ml alcohol (70% by volume).

Transfer a sample containing 30-140 mg chloride (usually about one g of the quaternary ammonium salt) into a 300 ml Erlenmeyer flask, dilute to 75 ml, and add 25 ml isopropyl alcohol. Neutralize if necessary with 10% acetic acid, using a drop of bromothymol blue indicator (a). Add 10 drops dichlorofluorescein soln (b) and titrate with standard 0.1 *N* silver nitrate soln, avoiding direct sunlight. The precipitate becomes red at the end point, and may flocculate just before the end point is reached. Calculate the percentage of chloride (1 ml 0.1 *N* AgNO₃-0.0035457 g Cl) and the equivalent percentage of quaternary ammonium salt.

NOTES

- (1) Exposure to sunlight causes rapid darkening of the precipitate.
- (2) The solution should contain at least 15 mg Cl per 100 ml and the pH should be greater than 4, that is only faintly acid.

More specific methods involve reaction of the high molecular weight cation with an anion to form a salt which is either insoluble or which may be extracted by means of organic solvents. Examples of insoluble salts are the ferrocyanides, ferricyanides, silicotungstates, dichromates, and permanganates. A method utilizing the ferricyanide salt has been described¹ and has been made first action.

With dyes such as tetrabromophenolsulfonphthalein (bromophenol blue) in alkaline solution, the quaternary ammonium compounds form colored salts, which may be extracted with organic solvents such as benzene or ethylene dichloride. The intensity of the color may then be determined colorimetrically as in the Auerbach Method². This method appears to be practical for the analysis of products containing small amounts (about 0.1%) of the quaternary ammonium compound.

Several commercial products were analyzed by these methods with the following results:

TABLE I.-Comparison of results

PRODUCT	METHOD				
	ELECTROMETRIC TITRATION		ADSORPTION INDICATOR		FERRICYANIDE
	CHLORIDE	QUAT. AMM. COMPOUND	CHLORIDE	QUAT. AMM. COMPOUND	QUAT. AMM. COMPOUND
	<i>per cent</i>	<i>per cent</i> ^t	<i>per cent</i>	<i>per cent</i>	<i>per cent</i>
(1) Para diisobutyl phenoxy ethoxy ethyl dimethyl benzyl ammonium chloride monohydrate	7.63	100.3	7.64	100.4	99.3
(2) Alkyl dimethyl benzyl ammonium chloride 50% (Calculated as lauryl)	5.57	53.4	5.54	53.1	-
(3) Methyl dodecyl benzyl trimethyl ammonium chloride 50%	-	-	5.29	54.9	End-points were not satisfactory
(4) Product containing compound (1) above	1.475	19.39	1.468	19.30	19.30
(5) Product containing compound (1) above	0.744	9.78	0.748	9.83	9.65

REFERENCES

- (1) A. S. DUBOIS, *Ind. Eng. Chem., Anal. Ed.*, 17, 744 (1945).
- (2) KOLTHOFF and SANDELL, "Textbook of Quantitative Inorganic Analysis," Revised Edition, pp. 571 il. (1946).

^t J. B. WILSON, *This Journal*, 29, 312 (1946).

• M. F. AUERBACH, *Ind. Eng. Chem., Anal. Ed.*, 15, 492 (1943); 16, 739 (1944).

RECOMMENDATIONS.

It is recommended-

(1) That collaborative study be made of the electrometric titration and the adsorption indicator method (Fajans Method) for halides in quaternary ammonium salts.

(2) That collaborative study be made of the ferricyanide method to establish its applicability to determination of quaternary ammonium compounds in disinfectants.

(3) That the colorimetric methods be further studied with a view of their application to relatively dilute solutions of quaternary ammonium compounds in commercial preparations.

REPORT ON ORGANIC THIOCYANATES

By HERBERT A. ROONEY (California State Department of Agriculture, Bureau of Chemistry, Sacramento 14, California), *A880ciate Referee*

J. W. Elmore¹ devised a procedure² for determining organic thiocyanate nitrogen in insecticides containing various organic thiocyanate compounds. Formerly routine laboratory analyses were confined to total nitrogen or sulfur determinations from which the percentage of organic thiocyanates present was calculated. Analyses based on sulfur or nitrogen are obviously unsatisfactory in the presence of other compounds containing these two elements.

In the Elmore procedure organic thiocyanates are treated with potassium polysulfide reagent to form inorganic thiocyanates. Following precipitation of the inorganic thiocyanate as cuprous thiocyanate, a Kjeldahl analysis is made on the latter to determine the amount of organic thiocyanate, calculated from thiocyanate nitrogen, in the original substance.

This collaborative study was limited to liquid organic thiocyanate preparations commonly used in livestock and fly sprays. Four samples were prepared and sent to collaborators with reprints of the Elmore procedure. Collaborators were directed to determine organic thiocyanate nitrogen by the Elmore method and total nitrogen from a Kjeldahl digestion and to report results to the nearest 0.01%. (See Table 1.)

COLLABORATORS

California Spray Chemical Corporation, Richmond, California.

Hercules Powder Co., Inc., Wilmington, Delaware.

Paul E. Irwin, Division of Chemistry, Commonwealth of Virginia.

Rohm and Haas Company, Inc., Philadelphia, Pennsylvania.

Herbert A. Rooney, California State Department of Agriculture, Sacramento 14, California.

* For report of Subcommittee A and action of the Association, see *This Journal*, 34, 42 (1951).

¹ Formerly Senior Chemist, Bureau of Chemistry, California Department of Agriculture, retired August, 1948.

² *This Journal*, 28, 363 (1945).

KEY TO UNKNOWN SAMPLES

Sample 1. A concentrate containing approximately 50% beta-butoxy-beta-thiocyano diethyl ether, or approximately 4% organic thiocyanate nitrogen in petroleum oil.

Sample 2. A kerosene solution of beta-butoxy-beta-thiocyano diethyl ether containing approximately 0.20% organic thiocyanate nitrogen.

Sample 3. A secondary terpene alcohol thiocyanyl acetate containing approximately 4.3% organic thiocyanate nitrogen.

Sample 4. Normal butyl thiocyanate containing approximately 11.8% organic thiocyanate nitrogen.

COLLABORATOR'S DIRECTIONS FOR ANALYSIS

The collaborators were instructed to follow the method described by Elmore with the following revisions:

1. Use the shaking procedure, as described, *This Journal*, 28, 370 (1945).
2. Change "15 minutes" in the tenth line under "Determination of thiocyanate nitrogen," page 370, to "2 hours."

TABLE I.—Results of analysis

COLLABORATOR	ORGANIC THIOCYANATE NITROGEN				TOTAL NITROGEN BY KJELDAHL			
	SAMPLE NO.				SAMPLE NO.			
	1	2	3	4	1	2	3	4
A	3.86	0.20	4.20	11.48	3.91	0.20	4.37	11.65
B	3.83	0.20	4.24	11.61	3.91	0.20	4.36	11.85
C	3.83	0.192	4.24	11.50	3.86	-	4.26	11.4
	3.84	0.194	4.28	11.60	3.89	-	4.32	11.5 11.6
D	3.87	0.177	4.07	11.44	3.85	0.178	4.34	11.51
	3.85	0.176	4.21	9.01	3.88	0.180	4.28	11.66
	3.85	0.191	4.05	8.04 9.48	3.90	0.191	4.31	11.46 11.51
E	3.94	0.197	4.31	11.78	3.95	-	4.32	11.78

COMMENTS OF COLLABORATORS

Hercules Powder Co. "From our experience with the Elmore method, we would say that our main difficulty has been encountered in the filtering of the cuprous thiocyanate. The precipitate either runs through the filter or else clogs it. We have found the following combination satisfactory and wish to pass along the information to anyone who may have difficulty: Two sheets of Whatman No.1 filter paper are placed in a 2.5-inch diameter BUCHNER funnel fitted to a suction flask; approximately 4 grams of Celite 535 are placed on the paper and are then covered by two more sheets of the No.1 paper. Aside from the above, we found the procedures to be satisfactory."

Rohm and Haas Company: "1. Commercial organic thiocyanate concentrates such as Lethane 384 (contains $C_4H_9OC_2H_4OC_2H_4SCN$), Lethane A-70 (contains 0 (C.H.SCN).), Thanite (contains NCSC.H.CO. fenchyl), and n-butyl thiocyanate may be accurately analyzed by the Elmore method.

"2. Somewhat low (93%) but probably acceptable results are obtained with ester-type thiocyanates such as Lethane 60 (contains esters averaging $C_{12}H_{25}CO_2C_2-H.SCN$).

"3. Fly spray strength solutions of Lethane 384 may be accurately analyzed by the Elmore method.

"4. The presence of such additives as DDT, Methoxychlor, Chlordane, Lindane, piperonyl butoxide and pyrethrum do not interfere with the analysis of Lethane 384 fly spray strength solutions.

"5. The most unsatisfactory part of the Elmore method is the filtration of the precipitated cuprous thiocyanate. The following revision was found to give a clear filtration with every sample the first time through. After allowing the cuprous thiocyanate precipitate to settle for 2 hours, the sample was centrifuged at 2000 r.p.m., the top speed of the centrifuge, for 10-15 minutes. A 2-inch Buchner funnel coated with a layer of asbestos fibers, upon which was placed a #42 Whatman filter paper, then a second layer of asbestos fibers, a layer of filter eel and finally a third layer of asbestos fibers was used for the filtration."

Other comments, Rohm and Haas. "It is felt that the method is satisfactory as a general one, especially if used in conjunction with Kjeldahl analyses. It is, however, quite possible that questionable results will be obtained with certain commercial samples and that a complete and final evaluation of the method will come only with further experience."

Paul E. Irwin. "It will be noted that the results by Elmore's method for sample No.4 did not check. These analyses were run at the same time as the others and nothing unusual was noted that might indicate why they did not check. Unfortunately, our time was limited and we could not do further work to try to find the cause of this.

"A slight modification in Elmore's method was made as follows: After boiling for 8 minutes to remove hydrogen sulfide, the solution was cooled and filtered before making the second extraction with petroleum benzene to remove fatty acids and other oils. So much sulfur was present after boiling that it was difficult to extract without first filtering.

"The filtration of cuprous thiocyanate was made using a carbon filter fitted with a porcelain filter disc with aluminum rod attached for pushing out disc and filter pad. The filter pad was built up with two coats of filter paper pulp, each of which was tamped tight, and then 2 layers of filter eel were likewise tamped tight. This procedure worked very satisfactorily.

"No particular difficulty was experienced with the method except for our failure to get checks on sample No.4."

RECOMMENDATIONS.

It is recommended that the following revision of the Elmore method for the determination of organic thiocyanate nitrogen in livestock or fly sprays be adopted, first action.

REAGENTS

(a) *Strong potassium polysulfide soln.*-Dissolve 180 g of KOH in 120 ml of water. Saturate 100 ml of this soln with H_2S (about 42 g) while cooling. Add the other 100 ml of KOH soln and 80 g of sulfur. Shake until dissolved.

* For report of Subcommittee A and action of the Association, see *This Journal*, 34, 42 (1951).

- (b) *Sodium sulfide*.—($\text{Na}_2\text{S} \cdot 9\text{H}_2\text{O}$).
 (0) *Mixed sulfide soln.*—To 100 ml of (a) add 50 g of (b), 80 g of KOH, and 200 ml of water.
 (d) *Sodium bisulfite*.—($\text{Na}_2\text{S}_2\text{O}_5$ or NaHSO_3).
 (e) *Sulfur dioxide*.
 (f) *Copper sulfate soln.*—(20% $\text{CuSO}_4 \cdot 5\text{H}_2\text{O}$).
 (g) *Potassium hydroxide 80ln.*—(10%).
 (h) *Sulfuric acid.*—(1+4).
 (i) *Wash soln.*—To 300 ml of water add 1 ml. of (h), 1 g of (d), 10 ml of (f), 12 g of $\text{Na}_2\text{S}_2\text{O}_4$, and pass SO. into the soln for 10 min.

DETERMINATION

Weigh an amount of sample preferably containing ca 0.08 g of thiocyanate nitrogen into a 250 ml glass-stoppered Erlenmeyer flask. (If the percentage is very low, the weighed amount should not be increased unduly without correspondingly increasing the quantity of mixed sulfide soln (0) used: 20-25 g of fly spray is usually sufficient.) Add 35 ml of the mixed sulfide soln (0). Shake vigorously at room temp. for 10 min., during which time reaction is nearly completed: next heat to 70°C. on a steam bath, carefully releasing the pressure resulting from heating; and shake at the temp of 70°C. for 15 min. more. Cool.

Removal of petroleum oil.—Dilute and transfer to a separatory funnel with about 200 ml of water. Add 50 ml of petroleum ether, shake, and draw off the aqueous layer into a 600 ml beaker. Wash the petroleum ether layer with two 10 ml portions of water, which add to the main soln. (If emulsions occur during the washing process, they may be broken by acidifying with H_2SO_4 (1+4). The aqueous layer may then be drawn off and the petroleum ether layer washed with water as directed.) Discard the petroleum ether layer.

Determination of thiocyanate nitrogen.—Dilute the water soln to about 300 ml and neutralize with H_2SO_4 (1+4), using a piece of litmus paper as outside indicator. Add 2 ml of H_2SO_4 (1+4). Bring the mixture to a boil quickly and boil for 8 min. to remove H.S. Cool. If fatty acids or other oils are present at this stage, transfer to a separatory funnel, extract with petroleum ether, and return the aqueous phase to the original beaker. Filter thru a small Buchner funnel and transfer the filtrate to a beaker. Neutralize to litmus paper with KOH 10% and add 1 ml of H_2SO_4 (1+4). Add about 1 g of $\text{Na}_2\text{S}_2\text{O}_5$ and stir until dissolved. Add excess (about 15 ml) of 20% $\text{CuSO}_4 \cdot 5\text{H}_2\text{O}$ soln and pass SO. into the soln for 10 min. Allow the precipitated cuprous thiocyanate to settle for 2 hours and filter with suction thru a 2 inch Buchner funnel. Coat the Buchner funnel with a layer of asbestos fibers, upon which is placed a No. 42 Whatman filter paper, a second layer of asbestos fibers, a layer of diatomite, and finally a third layer of asbestos fibers. If the filtrate is not clear, centrifuge the sample at 2000 r.p.m. for 10-15 min. and pour thru the filter a second time. Wash the filter and precipitate once or twice with the wash soln, continue suction until filter pad is dry, and transfer to an 800 ml Kjeldahl flask. (This may conveniently be done by folding it in a filter paper together with bits of moist filter paper used to wipe out the Buchner funnel. Then place the whole in the Kjeldahl flask.) Add a few glass beads, 35 ml of concentrated H_2SO_4 , 10 g of K_2SO_4 , and ca 0.7 g of HgO or 0.6 g of metallic Hg. Digest until white and for 15 min. thereafter. Determine the nitrogen by the official method, beginning with the words "After cooling, dilute" Run a blank analysis on the paper and filtering pad.

• *Methods of Analysis*, A. O. A. A., 1945, page 26, paragraph 2.24.

REPORT ON PHENOLIC DISINFECTANTS

By W. A. AFFENS (Insecticide Division, Livestock Branch, Production and Marketing Administration, United States Department of Agriculture, Beltsville, Maryland), *Associate Referee*

INTRODUCTION

Since the Association of Official Agricultural Chemists has no procedure at the present time for the analysis of coal-tar disinfectants, a preliminary study has been made of the standard methods now available with a view toward establishing such a method by the Association. The determination of phenols has been investigated in particular, and certain recommendations are being made to incorporate essential features now in use and include some modifications found to be desirable. Nonstandard methods for the determination of phenols (such as colorimetry, bromination, iodination, etc.) have not as yet been investigated in this study.

STANDARD METHODS

The determination of total phenol compounds ("tar acids") in mixtures such as coal-tar disinfectants, creosote, coal tar, and other phenolic mixtures by standard methods, generally employed, usually involves: (a) Separation of the phenols by distillation (employing steam or oils as a distillation vehicle); (b) isolation of the phenols by extraction with aqueous sodium hydroxide solution; and finally (c) measurement of the isolated phenols. Although various techniques are used to carry out these operations, in general they are modifications of the methods of Chapin (1, 2, 3), Hill (4), and Weiss (5). Procedures for the determination of phenols employed by such standard references as the *Pharmacopoeia of the United States of America* (U.S.P. XIII) (6), *Book of American Society for Testing Materials Standards* (7), and Allen's *Commercial Organic Analysis* (8) are based on these operations, and they have been in use for many years.

U.S.P. METHOD

The U.S.P. method (6) for the analysis of *liquor cresolis saponatus* has been found generally applicable in this laboratory for the determination of low boiling coal-tar phenols in liquid disinfectants (containing relatively large concentrations of phenol), but was found to yield low results when applied to samples containing high boiling phenols of either coal tar or petroleum origin. This is in accordance with the findings of Tucker (9), and others, such as Taylor (10), who have reported that high boiling phenols will not distill over completely with steam or with low boiling oils. The U.S.P. method requires that a 50 ml sample, to which 3 g of sodium bicarbonate and 150 ml of purified kerosene (boiling range 180°-300°C.) have been added, be distilled "until the distillate comes over strongly yellow." The water layer in the distillate is drawn off and discarded,

the distillate is then washed with 10 ml of 50% sulfuric acid, and the acid layer discarded. The distillate is then extracted twice with measured quantities of 15% aqueous sodium hydroxide solution, and the increase in volume of the combined sodium hydroxide solutions is then measured and recorded as the volume of phenols derived from the sample. It is noted that the final boiling point at which distillation is completed is not specified, nor is a method given for purification of the kerosene.

TABLE 1.-*Phenol recovery by U.S.P. procedure comparing various oils used for distillation*

(Commercial tar acid sample, "100 % Tar Acids"*)

OIL	DISTILLING RANGE OF OIL °C.	DISTILLING RANGES °C. PHENOL DETERMINATION	PHENOLS RECOVERED PER CENT BY VOLUME
Deodorized Kerosene	202-274	(distillation omitted)	93
Deodorized Kerosene	202-274	150-270	82
Diesel Fuel Oil	178-315	160-315	92
Lubricating Oil #10	300-500 ^b	225-360	92
Crystal & Neutral Oil	300-500 ^b	225-360	92

* Small amount of water in phenol sample. Product distills 240--282°C. (92%).

^a Distillation stopped when decomposition was noted.

^b These figures are estimates since decomposition occurs far below the top distilling point.

TABLE 2.-*Phenol recovery in samples of liquor cresolis saponatus, U.S.P. XIII, by U.S.P. procedure comparing deodorized kerosene with Diesel fuel oil*

SAMPLE	RECOVERED PHENOLS (DEODORIZED KEROSENE)	RECOVERED PHENOLB (DIESEL FUEL OIL)
	<i>per cent</i>	<i>per cent</i>
No. 1	49.0	50.2
No. 2	36.0	51.0

BOILING RANGE OF DISTILLING OILS

Because of the low results obtained with samples containing high boiling phenols (approximate range of 280°0.) when the U.S.P. method was applied using, for example, deodorized kerosene (approximate boiling range: 202-274°0.), that had given satisfactory results with lower boiling phenols, it was decided to investigate the use of higher boiling oils for the distillation of the phenols. In all cases, the oil was purified by extraction and washing with 10% of its volume of 15% sodium hydroxide solution and finally with several portions of distilled water until free of alkali. Results obtained with higher boiling oils were in all cases found to be higher than those obtained with deodorized kerosene, and were in agreement with the actual quantity of phenols in the samples, and the results using the three oils checked with each other. Results are given in Tables 1 and 2.

Examination of the data in Tables 1 and 2 indicates the significance of the boiling range of the kerosene in applying the U.S.P. method to samples containing high boiling phenols. The 93% result obtained when deodorized kerosene was added to the sample, distillation omitted, and treated as directed in the U.S.P. method following the distillation step, appears to be slightly high. This may be due to a small quantity of acidic substances that would not have distilled in the U.S.P. procedure and which increased the volume of recovered phenols. Because considerable difficulty was experienced in the heating while distilling the two lubricating oils up to 360°C., the Diesel fuel oil was selected for use in the distillation, since this oil also yielded accurate results, and gave no difficulty in its distillation, except that it was necessary to substitute a Meker burner towards the end of the distillation. Other phenol derivatives have been tested, and so far none has had a maximum boiling range above 282°C. It appears, therefore, that the Diesel fuel oil (178-315°C.) is satisfactory, especially when applied to coal tar disinfectants. It should be observed that in applying the U.S.P. method for determination of phenols, that the oil used for distillation should have a maximum boiling point in excess of that of the phenols in the sample, and that distillation during the determination must be carried up to a temperature in excess of that of the maximum distilling temperature of the phenols.

MEASUREMENT OF PHENOLS

The U.S.P. procedure, modified as previously described, was found to be generally satisfactory for samples that contained relatively high concentrations of phenols (25 to 50%). However, for samples containing smaller quantities of phenols the method required further modification. In the U.S.P. procedure, the phenols are measured by noting the increase of volume of the sodium hydroxide solution in a graduated cylinder. This method of measuring volume is not sufficiently accurate for smaller amounts of phenols, and it was found desirable to use the modification suggested by Tucker (9) in which the combined sodium hydroxide solutions are measured in a 100 ml Tar Acid funnel. This modification is also applicable, of course, to samples of higher phenol concentration.

CONTRACTION VS. LIBERATION METHOD

It has been suggested by Weiss (5), Fisher and Eisner (11), Field and Steuerwald (12), and others that the "contraction" method (of which the U.S.P. method is a variation) yields high results because of absorption of oil in the sodium hydroxide solution (due to the fact that phenolates dissolve some of the kerosene), and these authors prefer the "liberation" method in which the phenols are liberated with acid and measured directly. This point has not been studied in this investigation, but a few samples tested by both the contraction and liberation method gave identi-

cal results. The American Society for Testing Materials (7) method can be employed in the above procedure (after the extraction with sodium hydroxide solution) beginning with the step in which the alkaline solution is acidified with sulfuric acid, if the liberation method is preferred. Another alternative, suggested by Field and Steuerwald (12), is to correct for this error in the contraction method by washing the alkaline solution of phenolates with a solvent, such as petroleum ether, to remove kerosene.

REAGENTS

Considerable variation and disagreement unfortunately exists among most authors as to the nature, quantity, and concentration of the numer-

TABLE 3.—Variations in concentration of sulfuric acid and sodium hydroxide recommended by various authors

METHOD	NaOH	H ₂ SO ₄
	BY WEIGHT	BY WEIGHT
	<i>per cent</i>	<i>per cent</i>
U.S.P. XIII (6)	15	49-51
A.S.T.M. (7)	18.3	none
Chapin (3)	9-10	60-61
Weiss (5)	10	40
Hill (4)	10	none
Field and Steuerwald (12)	20	60-61
Fisher and Eisner (11)	10	20*
Taylor (10)	10	10
Tucker (9)	15	61-64t
Allen (8)	15-20‡	none

* Acid saturated with Na₂SO₄ or NaCl.

† 1:1 acid used.

‡ 10% NaOH used in an alternative method.

ous reagents used in the determination of phenols, and some of these are mentioned here as worthy of further investigation.

(A) *Sodium Bicarbonate.*—In the U.S.P. method (6), 3 g of NaHCO₃ are added to the sample prior to distillation. The purpose (3) of the NaHCO₃ is to adjust the *pH* of the sample so as to release phenols, but to hold back other acid substances which may be present, as their sodium salts.

Chapin (3), Taylor (10), and Tucker (9), for example, employ this step, although some authors omit it. Chapin and Taylor suggest the use of 2½ g of NaHCO₃; Taylor adds in addition 0.5 g of MgCO₃; and Tucker uses 10 to 12 g of NaHCO₃. The significance of these variations has not been demonstrated.

(B) *Sulfuric Acid.*—In the U.S.P. method (6), the distillate is washed with 10 ml of 49-50% H₂SO₄. The purpose of this washing (3) (11) is to remove basic substances (amines) and water from the oil layer. Variation

as to the proper concentration of the acid exists among various authors, and examples are shown in Table 3. As pointed out by Chapin (3), Field and Steuerwald (12), and Fisher and Eisner (11), this concentration is significant, since too low concentrations may not remove the undesired constituents, and may in addition dissolve out some of the phenols. Fisher and Eisner suggest saturation of the acid with Na_2SO_4 or NaCl to inhibit solution of phenols.

(C) *Sodium Hydroxide Solution.*-In the U.S.P. method (6), 15% aqueous NaOH is used to extract out the phenols. Fisher and Eisner (11) discuss this point in detail, and suggest the use of 10% NaOH . They claim NaOH that is too concentrated will also dissolve out tar bases, and other non-acidic material, whereas too weak NaOH (5%) forms emulsions with tar distillates. Examination of Table 3 indicates that the 10% NaOH is preferred by most authors.

SAMPLES OF LOW PHENOL CONCENTRATION

In addition to the factors previously discussed, further modification of present methods is necessary for samples of low phenol concentration (1-3%). In order to avoid excessively large samples, a more accurate method of measuring the phenols must be developed. Gravimetric measurement of the liberated phenols after extraction with ether has been used with fair success in this laboratory, but difficulty has been experienced in removing last traces of the extraction solvent without loss of low boiling phenols. A method by Moldavskii (13) suggests the use of a small calibrated tube and a centrifuge as a means of measuring small quantities of liberated phenols (contraction method). Based on this general idea, and using some of the techniques previously discussed, some preliminary work has been done with fair success by the following procedure:

METHOD

Treat about 50 ml of the sample as directed under assay for saponated cresol soln, in the U.S.P. XIII (6), using Diesel fuel oil which has been previously purified by extraction with one-tenth its volume of 15% NaOH , and then with distilled water until free of alkali. Follow the U.S.P. procedure up to and including the step in which the layer of sulfuric acid is discarded. Extract the oil distillate successively with two 10 ml portions of 15% NaOH by shaking each portion for 5 min., and allowing the layers to separate completely. The NaOH portions are drawn off into each of two separatory funnels, and the oil is discarded. Wash the NaOH solns successively with the same 40 ml portion of petroleum ether, and allow the layers to separate completely in each case. Transfer the NaOH solns to an 18-g 30% Babcock bottle (this size bottle is suggested, but not obligatory). Wash the petroleum ether with 10 ml of saturated NaCl soln, allow to settle completely, draw off the salt soln into the Babcock bottle containing the NaOH solns, and discard the ether. Heat the bottle carefully in a beaker of hot water on a steam bath to expel any residual petroleum ether. Cool in a beaker of ice water, add a measured 1.00 ml portion of xylylene. Carefully acidify with HCl , keeping the bottle and its contents cool, and

¹ This addition may be omitted if sufficient phenols are liberated for an accurate measurement, and if the phenols do not solidify at room temperature.

mix thoroly. Add saturated salt soln to bring the liberated phenols into the graduated area of the bottle, centrifuge the bottle, bring to room temp., and read the volume of liberated oil. Convert to ml and subtract the quantity of xylene added. Volume of liberated phenols in ml X 1.02 = **approximate**² weight of liberated phenols.

RECOMMENDATIONS*

It is recommended-

(1) That further study be made of a method for the determination of phenols in coal-tar disinfectants, based on the U.S.P. XIII method for assay of phenols in saponated solutions of cresol, paying attention to the distillation temperature, the strength of the NaOH solution, the strength of the sulfuric acid employed, and measurement of the phenols by use of a tar acid funnel, or other suitable measuring device.

(2) That the title of the subject studied by the Associate Referee be changed from *coal tar disinfectants* to *phenolic disinfectants*, which will include those of mineral oil origin.

REFERENCES

- (1) CHAPIN, R. M., U. S. Dept. Agric., Bur. An. Ind. Bul. 107 (1908).
- (2) — — —, *J. Ind. Eng. Chem.*, 12, 771-775 (1920).
- (3) — — —, U. S. Dept. Agric., Bur. An. Ind. Bul. 1308 (1924).
- (4) HILL, J. B., *J. Ind. Eng. Chem.*, 15, 799-800 (1923).
- (5) WEISS, J. M., *J. Ind. Eng. Chem.*, 10, 911-916 (1918).
- (6) The Pharmacopoeia of the United States of America, XIII, 154, Mack Pub. Co., Easton, Pa. (1947).
- (7) Book of A.S.T.M. Standards, *Amer. Soc. Test. Material* 8, II, 694, D-453-41 (1942).
- (8) ALLEN, A. H., Commercial Organic Analysis, III, 5th Ed., 289-296, Blakiston, Phil., Pa. (1925).
- (9) TUCKER, R. P., Calif. Dept. Agric. Spec. Pub. 219, 20 (1945-46).
- (10) TAYLOR, J. N., *This Journal*, 11, 222-225, (1928).
- (11) FISHER, C. H., and EISNER, A., *Ind. Eng. Chem., Anal. Ed.*, 9, 213-218 (1937).
- (12) FIELD, E., and STEUERWALD, L., *Ibid.*, 11, 426-428 (1939).
- (13) MOLDAVSKIL, B. L., *J. Chem. Ind. (Moscow)*, 12, 33 (1932).

REPORT ON PARATHION

By FRED I. EDWARDS, JR. (United States Department of Agriculture, Agricultural Research Administration, Bureau of Entomology and Plant Quarantine, Beltsville, Maryland), *Associate Referee*

In the 1949 report (1) the history and properties of the insecticide parathion were briefly reviewed and the existing methods of assay summarized and their shortcomings commented on. It was indicated at that time that all methods are subject to interference from allied compounds,

² If sufficient phenols are recovered (and no xylene added) the specific gravity can be determined directly.

* For report of Subcommittee A and action of the Association, see *This Journal*, 34, 43 (1951).

and recommended that work be done on the more promising methods to remove such interference.

During the year the method of O'Keeffe and Averell,¹ which utilizes a titration with standard sodium nitrite, and the polarographic method of Bowen and Edwards (2) were investigated. No remedy for the removal of the interference of the ethyl bis-p-nitrophenyl thiophosphate was found in either case. An additional problem in the titration method is the matter of an indicator. The method uses potassium iodide-starch paper to detect the end point, and several chemists have expressed their dissatisfaction with this indicator. However, no suitable substitute has been found, and work is being continued along this line.

A survey of eighteen laboratories indicates that some standard method is needed. Table 1 shows the methods used in each of these laboratories.

Of these methods the colorimetric procedure of Averell and Norris (3), the sodium nitrite titration method of O'Keeffe and Averell,¹ and the polarographic method (2) are in widest use.

The wide use of the colorimetric method is in direct conflict with the recommendations of Averell and Norris. In their description of the method they say, "The method of analysis described was developed for the purpose of determining very minute amounts of parathion such as might be expected in residues on fruit, vegetables, or foliage after spraying or dusting. For the analysis of parathion itself, or for the determination of parathion in commercial dusts or wettable powders, other methods are more suitable but are outside the scope of this paper." According to the writer's experience, a dilution of at least 1-1,000 is required and a minute error in dilution is multiplied to such an extent that results are questionable. Since Averell and Norris do not recommend the method for assay and since the experience of several chemists has been unsatisfactory, no further consideration of this method seems warranted.

The sodium nitrite titration method has in its favor simplicity and low cost of equipment. It is subject only to the usual interference errors and the indicator objection mentioned earlier. Essentially the method removes free p-nitrophenol by a mild alkaline wash, reduces the remainder of the sample to amines, and titrates these amine compounds with standard sodium nitrite, using potassium iodide-starch paper as an indicator.

The polarographic method (2) is a rapid and simple one, subject only to the errors from allied compounds which are common to all the methods. The major objection is the initial cost of the polarograph, which will range from about \$300 for a manual model to \$1,800 for a recording-type research instrument. These costs may be prohibitive for small laboratories, but where such an expenditure can be made, this method seems very worth while. There are two modifications of the polarographic method which have not yet been published, and no detailed descriptions can

¹ A description of this method can be obtained from the American Cyanamid Co., Stamford, Conn.

be given at this time. However, the modifications lie in the electrolyte and buffer and the reliability and ease are the same.

Although none of the methods for determination of parathion is completely satisfactory, it is necessary that some standard procedure be considered. The use of at least nine methods can only lead to confusion and disagreement in the field. Therefore, the recommendation* is made that collaborative studies be carried out on the polarographic and the sodium nitrite titration methods, and on any new methods that show promise.

REFERENCES

- (1) EDWARDS, F. I., *This Journal*, 33, 783 (1950).
- (2) BOWEN, C. V., and EDWARDS, F. I., *Anal. Chem.*, 22, 706 (1950).
- (3) AVERELL, P. R., and NORRIS, M. V., *Ibid.*, 20, 753 (1948).

REPORT ON BENZENE HEXACHLORIDE

By C. V. BOWEN (Bureau of Entomology and Plant Quarantine, Agricultural Research Administration, U. S. Department of Agriculture, Beltsville, Md.), *Associate Referee*

RECOMMENDATIONS†

It is recommended-

- (1) That the modified partition chromatographic method as adopted as first action in 1949 and reported in *This Journal*, 33, 774 (1950) be adopted as official for the determination of the gamma isomer in technical benzene hexachloride.
- (2) That the infrared spectrometric method be adopted as official for the determination of the gamma isomer in technical benzene hexachloride.
- (3) That the modified partition chromatographic method be adopted as official for the determination of the gamma isomer of benzene hexachloride in wettable powder and dust insecticidal formulations.
- (4) That the investigation of the analysis for the gamma isomer of benzene hexachloride in emulsion concentrates and solutions, and in formulations containing other organic insecticides be continued.

No reports were given on tetraethyl phosphate; dimethyl dithio carbamates; DDT; oil emulsions; or sodium fluoroacetate.

* For report of Subcommittee A and action of the Association, see *This Journal*, 34, 42 (1951).

† For report of Subcommittee A and action of the Association, see *This Journal*, 34, 42 (1951).

REPORT ON DISINFECTANTS

By L. S. STUART (Production and Marketing Administration, Insecticide Division Department of Agriculture, Washington, D. C.), *Referee*

There is a serious need for some new official test procedure that can be employed to confirm results obtained by the official phenol coefficient method, or as a replacement for this method, with quaternary ammonium germicides and other germicides, where it can be shown that the phenol coefficient procedure gives results which may be misleading.

A number of test methods for quaternary ammonium germicides have been proposed and preliminary collaborative investigations seem to indicate that those methods which determine the killing capacity—that is, the number of organisms which a given volume of a specified concentration will kill in a selected time interval—provide the most uniform results. A rather extensive collaborative testing program was initiated, therefore, to determine if a use dilution method of this type could be made sufficiently precise to warrant consideration by the Association as an official method. The critical factor with all methods of this type is the number of organisms used. The problem which must be solved by collaborative testing is whether this factor can be controlled with a sufficient degree of precision to make an official method of this type practical. Results reported to date are inconclusive and no recommendation can be made at this time.

During the year, Dr. Pelzcar of the University of Maryland, Department of Bacteriology, was appointed as Associate Referee on the standardization of culture media for disinfectant testing. This appointment could not be made effective until late in the year and was accepted with the understanding that sufficient work could not be completed to warrant a report at this meeting. The objective of this program is to develop a test culture medium that employs only ingredients which can be accurately defined chemically so as to avoid variables due to differences in bacteriological peptones and beef extracts.

Preliminary collaborative tests were conducted to determine if certain minor revisions in the technique of the present method for Fungicides would yield more uniform results. It seems quite clear that propagation of the test culture at a *pH* level of 6.2 to 6.5, instead of the 5.5 to 5.6 level prescribed in the present procedure, is necessary to obtain uniform resistance of the spores at the concentration of phenol required. Also, propagation of the test culture by inoculating 15-18 ml of sterile melted agar in a test tube at 45°C. with 0.2 ml of an aqueous suspension of spores containing 5 million conidia per ml, pouring the mixture into a petri dish, allowing it to solidify, and incubating at 30°C. for 10 days, seems to provide a heavier crop of spores more uniform as to age and resistance to phenol than the procedure now specified. A more extensive collaborative testing

program has been planned for the coming year to obtain sufficient data to justify some recommendation for change on these two points.

It is recommended* that the three lines of investigation mentioned above be continued during the coming year.

REPORT ON PLANTS

By E. J. MILLER (Michigan Agricultural Experiment Station East Lansing, Michigan), *Referee*

The following is a brief report of the activities of the Associate Referees on Plants.

The Associate Referee on Cobalt and Copper in plants, has prepared a detailed outline and procedure for the estimation of cobalt in plants.

The Associate Referee on Starch in plants, has carried out a collaborative study of the method presented last year for the determination of small amounts of starch in plants, using alfalfa leaf meal, buckwheat leaves and peanut meal.

The Associate Referee on Sugars in plants, and Arthur Bevenue have continued with their study on clarification procedures using both fresh vegetables and fruits and dehydrated vegetables.

The Associate Referee on Zinc in plants, with the assistance of Eunice J. Heinen, has made substantial improvements in the dithizone method for the determination of **zinc** in plant materials, centering the research on (1) the ashing of the samples of plant material, (2) the extraction of **zinc** from the ashed sample, and (3) the improvement of the one-color procedure designed to eliminate the necessity of diluting the carbon tetrachloride solution of **zinc** dithizonate.

RECOMMENDATIONSt

It is recommended-

(1) That these Associate Referees listed on page 4, *This Journal*, 33, 1950, continue with their respective assignments.

(2) That the following recommendations by the Associate Referees be accepted:

Cobalt. That collaborative study be made of the modified ortho-nitrosocresol method for the determination of Cobalt in plants by Gregory, Morris and Ellis.

Sugars. That the investigation of **methods** of clarification of plant materials preparatory to sugar analysis be continued.

Starch. That further study be made of the method as applied to plant materials containing less than 5 per cent of starch, and that some con-

* For report of Subcommittee A and action of the Association, see *This Journal*, 34, 43 (1951).

† For report of Subcommittee A and action of the Association, see *This Journal*, 34, 43 (1951).

sideration be given to the establishment of appropriate factors for the method.

Zinc. (1) That the study be continued, particularly with regard to the improvement of the ashing procedure. (2) That the modified procedure be tested by collaborative studies.

The Associate Referees on Plants are to be commended for the substantial progress they have made during the past year in their respective assignments and it is to be hoped that they will be able to continue with their studies.

REPORT ON ZINC IN PLANTS.

By EUNICE J. HEINEN and ERWIN J. BENNE (*Associate Referee*)
(Michigan Agricultural Experiment Station, East Lansing,
Michigan)

The method given in the Plant Chapter of *Methods of Analysis, A. O. A. C.* (1) for determining zinc in plant materials depends upon the formation of a red compound of zinc and dithizone (diphenylthiocarbazone) in an ammoniacal aqueous solution. This colored compound together with some excess dithizone is extracted from the aqueous solution with carbon tetrachloride, and the amount of zinc present is evaluated photometrically by use of a mixed-color procedure.

Cowling and a number of collaborators studied this method, and their findings were reported in *This Journal* in 1941 (2). Results of subsequent studies of the method by the present Associate Referee and his colleagues were reported in *This Journal* in 1948 (3) and 1949 (4), respectively.

The report published in 1948 (3) gave results supporting the practice of removing the excess dithizone from the carbon tetrachloride solutions of zinc dithizonate and evaluating the zinc by a one-color instead of a mixed-color procedure. In the report published in 1949 (4) a further modification of the original procedure, designed to lessen the time required for carrying out an analysis, was described. Data were given showing the agreement between results obtained by the mixed-color and modified one-color procedures.

Studies described in this report have centered around the following:

1. Ashing the samples of plant material-(a) In platinum dishes and in porcelain crucibles. (b) With and without the addition of sulphuric acid when porcelain crucibles were used.
2. Extraction of zinc from the ashed sample.
3. An additional modification of the one-color procedure designed to eliminate the necessity of diluting the carbon tetrachloride solution of zinc dithizonate as in the original procedure.

Each of the above studies will be treated in the sequence given.

* Published with the approval of the Director of the Michigan Agricultural Experiment Station, as Journal Article No. 1272.

EXPERIMENTAL AND RESULTS

The A.O.A.C. procedure recommends that the samples of plant material being analyzed for zinc be dry-ashed in platinum dishes. Since the number of platinum dishes in many laboratories may be quite restricted, the authors decided it was worth while to attempt to determine whether porcelain crucibles might be successfully substituted for this purpose. Also, the A.O.A.C. method does not recommend the use of any ashing aids or fixatives for use with the dry-ashing process. In a previous report (4) it was suggested that the addition of sulphuric acid prior to ashing appeared to be advantageous when working with some types of plant materials; hence, additional attention was given to this suggestion. Results obtained with samples of several kinds of plant materials ashed in platinum dishes, and in porcelain crucibles with and without the addition of sulphuric acid, are given in Table 1.

TABLE 1.-Analytical results-platinum or porcelain dishes

PLANT TISSUE ANALYZED	P.P.M. OF ZINC DETERMINED					
	ASHED IN PLATINUM DISHES DUPLICATE RESULTS		ASHED IN PORCELAIN CRUCIBLES			
			WITHOUT H ₂ SO ₄ DUPLICATE RESULTS		WITH H ₂ SO ₄ DUPLICATE RESULTS	
Alfalfa meal	28.4	28.8	26.4	27.2	29.6	30.0
Celery leaves & stalks	29.6	28.4	30.8	31.6	27.6	25.6
Corn grain	-	-	23.2	26.8	24.4	26.8
Lettuce leaves	117.6	114.4	110.4	112.8	114.4	115.2
Mustard leaves	-	-	46.8	47.2	48.4	49.6
Onion bulbs	23.6	26.4	26.8	23.2	-	-
Pea seeds	20.0	-	20.4	19.2	23.2	23.2
Sugar beet roots	15.2	-	15.2	13.2	14.8	14.8
Wheat grain	31.2	33.2	33.2	32.4	-	-

The A.O.A.C. procedure specifies that zinc be extracted from the ashed sample by heating it with normal hydrochloric acid solution on the steam-bath until all soluble material has been brought into solution. Since this practice often requires considerable time, attempts were made to determine whether the digestion period could be lessened by the use of boiling concentrated hydrochloric acid. Comparative values for zinc obtained by digesting replicate samples of ash according to the A.O.A.C. procedure and by boiling others for 2 minutes with concentrated hydrochloric acid are given in Table 2.

As stated at the beginning of this report, in the A.O.A.C. method for determining zinc, the zinc dithizonate and some excess dithizone are extracted from an ammoniacal aqueous solution with carbon tetrachloride, and the zinc present is evaluated photometrically by a mixed-color procedure. The reports on this subject published in 1948 (3) and 1949 (4)

TABLE 2.-Comparative values-digesting and boiling

PLANT TISSUE ANALYZED*	P.P.M. 01' ZINC DETERMINED			
	DIGESTED WITH <i>N</i> HOI ON THE STEAMBATH FOR 2 HRS. DUPLICATE RESULTS		DIGESTED WITH BOILING CONCENTRATED HOI FOR 2 MIN. DUPLICATE RESULTS	
Corn grain	23.2	26.8	21.2	25.2
Lettuce leaves	110.4	112.8	108.0	108.0
Onion bulbs	26.8	23.2	24.4	24.4
Pea seed	20.4'	19.2	18.8	19.1
Wheat grain	33.2	32.4	31.2	31.6

* Ashed in porocelain crucibles.

described a modification of the A.O.A.C. method, in which the excess dithizone was removed from the carbon tetrachloride solution of zinc dithizonate with .01 normal ammonium hydroxide solution, in order that a one-color procedure could be used for evaluating zinc. The latter report (4) also described how the first extraction of the ash extract with dithizone reagent could be eliminated from the original procedure.

The present authors have altered this one-color procedure still further. Originally a 5-gram sample was ashed; the ash extract was made to 100 ml; and a 10-ml aliquot, equivalent to 0.5 gram of sample, was used for the analysis after being diluted with 15 ml of distilled water. The authors found it advantageous to ash a 2-gram sample; to make the ash extract to 200 ml; and to use a 25-ml aliquot, equivalent to 0.25 gram of sample, for the analysis without further dilution. Because of these changes it became necessary to add 3.2 ml of normal hydrochloric acid to the neutralized ash extract, instead of 4 ml as previously stipulated, in order to have the same concentration of acid in the solution used for analysis.

The manner of diluting the final solution of zinc dithizonate was also changed. Previously, 10 ml of dithizone reagent were used and 5 ml of the final solution of zinc dithizonate were diluted to 25 ml with carbon tetrachloride before the zinc was evaluated. The authors used 25 ml of a more dilute solution of dithizone, prepared by diluting 1 volume of the original solution with 4 volumes of carbon tetrachloride, and the zinc present was evaluated in a portion of this extract without further dilution. This step definitely shortened the procedure, and it was also felt that the accuracy was improved since possible errors attendant with dilution were eliminated.

All of the changes made are included in the statement of procedure which follows.

MODIFIED PROCEDURE
REAGENTS

The same as in the A.O.A.C. method except for the following changes:
(a) Reagent (b) and 0.02 *N* HCl are no longer used.

(b) Two additional reagents are required: viz.,

(1) .01 *N* *NH.OH*, prepared by diluting 20 ml of *N* *NH.OH* to 2 liters. (This soln is referred to in the procedure as reagent (i).)

(2) *Le8s concentrated dithizone 8oln*, prepared by diluting 1 vol. of dithizone reagent (e) with 4 vols. of CCl_4 . (This soln is referred to in the procedure as reagent (j).)

(c) *A more dilute carbamate 8oln*, prepared by dissolving 1.25 g of diethyldithiocarbamate in 1 liter of H_2O , is used for reagent (g) since only half as much sample is represented in the aliquot of ash extract as formerly. This reagent should be stored in the refrigerator.

ASHING AND EXTRACTION OF ASH

Weigh 2 g of finely-ground, air-dried plant material into a porcelain crucible. Add 10 ml of *N* H_2SO_4 soln, and mix thoroly with the sample. Include crucibles for blank determinations. Heat on a steam bath until most of the water is removed, then dry in a hot-air oven at 105°C. to remove remaining water. Heat in a muffle furnace at 500–550°C. until ashing is complete. Remove from furnace, cool, and moisten the ash with a little water. Then add 10 ml of *N* *HCl* (more if necessary for some plant materials to insure an acid ash extract), and heat on a steam bath until all soluble material is brought into soln. (The data in the foregoing table indicates that adding 3-5 ml of conc. *HCl* to the cooled ash and boiling for 2 min gives comparable results.)

Add a few ml of hot water. Filter off the insoluble matter and collect the filtrate in a 200 ml volumetric flask. Wash the filter with hot water until washings are no longer acid to methyl red indicator. Add 2 drops of the methyl red soln to the filtrate in the volumetric flask, neutralize with *N* *NH.OH*, and add 3.2 ml of *N* *HCl*. Make to volume with water and mix.

REMOVAL OF INTERFERENCES, FORMATION OF ZINC DITHIZONATE, AND SEPARATION OF EXCESS DITHIZONE

Pipet an aliquot of the ash extract containing not more than 15 mmg of Zn into an amber-glass separatory funnel of 125 ml capacity. A 25-ml aliquot is satisfactory in the analysis of most plant tissues. If it is necessary to use a different volume of ash extract, add 0.4 ml of 0.2 *N* *HCl* for each 5 ml of ash extract less than 25 ml taken, or 0.4 ml of 0.2 *N* *NH.OH* for each 5 ml over 25 ml taken.

Add 10 ml of dithizone reagent (e) to the solution in the separatory funnel and shake vigorously for 1 min. Allow the layers to separate and draw off and discard the CO_2 layer. Add 2 ml of CCl_4 to the aqueous soln, and after permitting the layers to separate, draw off the CCl_4 layer. Repeat this rinsing process once. Then add 5 ml of CCl_4 , shake 15 seconds, and allow the layers to separate. Draw off the CCl_4 layer. Add 2 ml of CCl_4 to the aqueous soln, allow the layers to separate, and draw off the lower layer as before. Permit the CCl_4 which remains on the surface of the aqueous soln to evaporate before proceeding with the analysis.

Add 40 ml of soln A, 5 ml of carbamate reagent (g) and 25 ml of dithizone reagent (j) to the aqueous zinc soln. The carbamate and dithizone reagents should be accurately added from a pipet or buret. Shake the funnel and its contents vigorously for one min. After allowing the layers to separate, draw off the aqueous layer thru a fine-tipped glass tube connected to an aspirator pump by means of rubber tubing. To remove the excess dithizone from the CCl_4 layer, add 50 ml of .01 *N* *NH.OH*, and shake vigorously for 30 seconds.

EVALUATION OF ZINC PRESENT

Dry the stem of the funnel with a pipestem cleaner, and flush out with about 2 ml of the zinc dithizonate soln. Collect the remaining zinc dithizonate soln in

25 ml Erlenmeyer flask, or other suitable container, and stopper tightly. (Amber-glass containers are convenient for this purpose; however, colorless glassware is satisfactory if placed in a dark place until the transmission readings are made.)

Measure the per cent of light transmitted by each soln with a photoelectric colorimeter equipped with a light filter with maximum transmission near 535 $m\mu$. (A Sextant Green Corning glass light filter, No. 4010, has been found to be suitable for this purpose.) Use CCI as the transmission standard and make an appropriate correction for the amount of zinc present in the blank determination. Evaluate the quantity of zinc present from a curve relating concentration of zinc and light transmission prepared as follows:

Into 200 ml volumetric flasks place 0, 2, 4, 6, 8, 10, 12, and 14 ml portions, respectively, of the standard zinc soln containing 10 mg of zinc per ml. To each flask add 2 drops of methyl red indicator soln, neutralize with *N* NH₄OH, add 3.2 ml of *N* HCl, and make to volume with distilled H₂O. Pipet 25 ml aliquots of each of these solns, containing 0, 2.5, 5, 7.5, 10, 12.5, 15, and 17.5 mg of zinc, respectively, into amber-glass separatory funnels, and carry them thru the procedure as directed for the ash solns, beginning with "Pipet an aliquot of the ash extract-into an amber-glass separatory funnel-etc." Determine the per cent of light transmitted by each soln and plot these values against the corresponding amounts of zinc.

COMPARISON OF RESULTS OBTAINED BY THE TWO PROCEDURES

Extracts of the ash from several kinds of plant material were prepared, and the zinc in similar aliquots of each extract was evaluated by both the A.O.A.C. mixed-color and the modified one-color procedures. The results obtained are given in the following table:

TABLE 3.-Comparison of mixed-color and one color procedures

PLANT TISSUE ANALYZED	P.P.M. OF ZINC DETERMINED	
	A.O.A.C. MIXED-COLOR PROCEDURE	MODIFIED ONE-COLOR PROCEDURE
Alfalfa meal	28.8	28.4
Celery stalks and leaves	28.0	28.4
Corn grain	24.4	23.2
Lettuce	109.6	108.0
Mustard leaves	41.4	41.8
Oat grain	30.4	31.2
Onion bulbs	23.8	24.0
Pea seeds	23.6	24.0
Soybeans	65.2	64.0
Sugar beet leaves	23.6	23.6
Sugar beet roots	11.3	11.2
Wheat grain	30.6	31.6

DISCUSSION

Examination of the data in the first table shows that the zinc values obtained by ashing in platinum dishes or in porcelain crucibles agree about as closely as do the duplicate results obtained by either practice.

The same is true of results obtained with and without the use of sulphuric acid during the ashing process. Consequently, it seems safe to conclude that good porcelain crucibles can be successfully substituted for platinum dishes for use in ashing plant materials for the determination of zinc. Since the values obtained by adding sulphuric acid to the samples prior to ashing are not consistently higher than those from samples ashed without sulphuric acid, it does not appear that the acid helped to prevent loss of zinc during the ashing process; however, in some instances the character of the sulphated ash was such as to facilitate the extraction process.

The data in the second table indicate that digesting the ashed sample with boiling concentrated hydrochloric acid for 2 minutes was as effective in extracting the zinc as was digesting with normal hydrochloric acid solution for 2 hours on the steambath. However, there is evidence that imperfect ashing and incomplete extraction of zinc from the ash are factors in poor duplication of results; hence, the authors feel that the ashing and extracting processes should be studied further.

Good agreement in zinc values obtained by the A.O.A.C. mixed-color and the modified one-color procedures is shown by the data in the last table. This is encouraging because the modified procedure is considerably shorter and more applicable to a large number of samples than the former.

One of the difficulties encountered in both procedures, and one which the Associate Referee and his colleagues have been unable to correct, is the lack of reproducibility of light transmission values for the blank determinations. Unfortunately the cause of such variations is still obscure and requires further study.

RECOMMENDATIONS.

It is believed that certain phases of this method, particularly the ashing and extraction processes, could profit from additional study. Consequently, it is recommended-

- (1) That the study be continued.
- (2) That the modified procedure be studied collaboratively, if collaborators can be found.

LITERATURE CITED

- (1) *Methods of Analysis, A.O.A.C.*, 6th Ed., 1945.
- (2) COWLING, HALE, *This Journal*, 24, 520, 1941.
- (3) BENNE, ERWIN J., *et al.*, *Ibid.*, 31, 285, 1948.
- (4) — — —, *Ibid.*, 32, 276, 1949.

* For report of Subcommittee A and action of the Association, see *This Journal*. 34) 43 (1951).

REPORT ON STARCH IN PLANTS

By CARROLL L. HOFFPAUIR (Southern Regional Research Laboratory*, New Orleans, Louisiana), *Associate Referee*

In the report for 1949 (2) a method for the determination of small amounts of starch in plant material was described. This method involves extraction of starch from plant tissues with boiling calcium chloride solution, precipitation of the starch with iodine, regeneration of the starch with alcoholic sodium hydroxide, hydrolysis to glucose, and determination of reducing sugars by the Somogyi (3) method. The method has been studied collaboratively in accordance with last year's recommendation.

Three samples were selected for study: Alfalfa leaf meal, buckwheat leaves, and peanut meal. These samples offered a wide range of possible interferences so that considerable information could be obtained with a minimum of effort on the part of the collaborators. All of the samples were air-dried plant tissue so as to ensure testing the efficiency of the extraction procedure. They all contained considerable protein and nonstarch carbohydrates, both of which interfere unless removed by the purification steps of the method. In addition the alfalfa meal was quite low in starch, while the peanut meal contained a moderate amount, and the buckwheat leaves had a fairly high starch content for this type of material.

The samples were ball-milled to pass a 100-mesh sieve and allowed to come to moisture equilibrium before being sent to the collaborators. The instructions accompanying the samples requested that they be analyzed for starch by the method outlined in the Report on Starch in Plants for 1949 (2), a copy of which was furnished. In order that the values could be calculated to a dry weight basis the collaborators were requested to obtain a moisture value by determining the loss in weight of a 5-gram sample on drying for 2 hours at 101°C. in a forced draft oven. In order to convert glucose to starch, the factor 0.90 as specified in official method 27.33 (1) was used arbitrarily. For the determination of glucose in the starch hydrolyzates 1 ml of 0.005 *N* thiosulfate was considered to be equivalent to 0.135 mg of glucose as specified by Somogyi (3) and verified in the previous report (2).

The Associate Referee wishes to thank each of the five collaborators for the interest and cooperation necessary to make this report possible. The results shown in the table were contributed by:

F. R. Earle, Northern Regional Research Laboratory, Peoria, Ill.

C. O. Willits and Mildred S. Gaspar, Eastern Regional Research Laboratory Philadelphia, Pa.

E. J. Benne and Betty Taylor, Michigan State College Lansing, Mich.

* One of the laboratories of the Bureau of Agricultural and Industrial Chemistry, Agricultural Research Administration, U. S. Department of Agriculture.

C. R. Joiner and Mary A. McEniry, Food and Drug Administration, St. Louis, Mo.

Elizabeth R. McCall, Southern Regional Research Laboratory New Orleans, La.

DISCUSSION OF RESULTS

The values obtained show poor precision. This is not unexpected in view of the complexity of the method and the wide range of interferences in the samples. It was apparent, however, that the agreement between

TABLE I.-*Starch content of alfalfa, buckwheat leaves, and peanut meal (moisture-free basis)*

ANALYST	ALFALFA	BUCKWHEAT LEAVES	PEANUT MEAL
	<i>per cent</i>	<i>per cent</i>	<i>per cent</i>
1	0.29	8.5	5.8
	0.35	8.8	6.1
	— —	— —	— —
	Av. 0.32	Av. 8.65	Av. 5.95
2	0.32	10.25	5.83
	0.32	9.14	5.59
	— —	— —	— —
	Av. 0.32	Av. 9.70	Av. 5.71
3	0.40	9.38	7.61
	0.35	9.84	7.75
	— —	— —	— —
	Av. 0.38	Av. 9.61	Av. 7.68
4	0.22	10.21	6.86
	0.41	10.13	7.40
	— —	— —	— —
	Av. 0.32	Av. 10.17	Av. 7.13
5	0.38	8.64	7.95
	0.41	8.46	7.83
	— —	— —	— —
	Av. 0.40	Av. 8.55	Av. 7.89
Average	0.35	9.34	6.87

individual determinations and the agreement among analysts were considerably improved when the values obtained in preliminary determinations were discarded. Consequently, preliminary results were omitted from the values reported in Table 1.

On this basis the values for alfalfa range from 0.22 to 0.41 per cent and average 0.35 per cent. The variation in values for the buckwheat sample

is from 8.46 to 10.25 per cent. Several collaborators reported that they had difficulty with this sample. This may be due in part to the fact that its starch content is somewhat above the optimum range for the method. Similarly the values for peanut meal range from 5.59 to 7.95 per cent.

When analyzed by a colorimetric method (2) the following values for per cent starch were obtained: Alfalfa, 0.14; buckwheat, 9.70; and peanut meal, 6.68. The agreement of these values with the averages reported in Table 1 indicates that the method under investigation is reasonably specific for starch.

Several of the collaborators indicated that they encountered difficulties in the determination of glucose in the hydrolyzates. This is probably due to unfamiliarity with the method which may account for some of the variations in the results.

CONCLUSIONS

It is felt that the results show some promise for the method, particularly for plant materials containing very small amounts of starch. Consequently, further study of the method as applied to plant materials containing less than 5 per cent starch is recommended. Some consideration in future studies should be given to the establishment of appropriate factors for the method.

LITERATURE CITED

- (1) *Methods of Analysis*, 6th ed., Washington (1945).
- (2) HOFFPAUIR, C. L., *This Journal*, 33, 810 (1950).
- (3) SOMOGYI, M., *J. BioI. Chern.*, 160, 61 (1945).

REPORT ON SUGARS IN PLANTS

By KENNETH T. WILLIAMS (*Associate Referee*), and ARTHUR BEVENUE (Western Regional Research Laboratory,¹ Albany, California)

During the past year the Associate Referee and co-workers have continued the study of clarification procedures.

Three clarification procedures were compared on aliquots of extracts of many and varied fresh fruits and vegetables: (1) No clarification, (2) Baker and Adamson Code 1551 decolorizing carbon,² and (3) neutral, lead acetate. It was found that, in general, lead acetate was of no value as it did not improve the analytical results (3,4).

Studies were made on dehydrated vegetables, comparing neutral lead acetate clarification with ion-exchange resin treatment of the extracts. It was found that lead clarification did not always remove all of the non-

¹ Bureau of Agricultural and Industrial Chemistry, Agricultural Research Administration, U. S. Department of Agriculture.

² The mention of manufacturers and commercial products does not imply that they are endorsed or recommended by the Department of Agriculture over others not mentioned.

sugar reducing materials, but such substances were removed by ion-exchange resins, as shown by fermentation data (8). (There were no unfermentable reducing sugars detected in the vegetables studied.) Also, the resin-column method, previously described (7), and a new batch procedure using selected mixtures of cation- and anion-exchange resins were compared (8). The batch procedure, using selected resins, was as effective as the resin-column procedure and this modification provided a very simple method for removing non-sugar reducing substances from extracts of dehydrated vegetables preparatory to their analysis for sugars.

Throughout the investigation the Hassid micro ferricyanide method (5, 6) was compared with the *A.a.A.C.* micro copper method (2). In the analysis of many fresh fruits and vegetables and some dehydrated vegetables (4,8), the two methods were interchangeable. However, with some dehydrated vegetables, the ferricyanide values were higher than those obtained by the copper method (8). Studies with heat-damaged dehydrated carrot showed that it was impossible to obtain good replication by either the copper or ferricyanide method when neutral lead acetate clarification was used for this particular type of vegetable.

It was also observed that non-sugar reducing materials were formed in vegetables that had been dried under conditions favorable for producing a minimum amount of "heat-damage" or "browning." Therefore, in the preparation of plant materials for sugar analysis, the samples should not be dried prior to the extraction procedure. Instead, the fresh material should be immersed in hot redistilled alcohol, as directed by the official method of the *A.a.A.C.* for plants (1).

It is recommended* that the investigation of methods of clarification of plant materials preparatory to sugar analysis be continued.

BIBLIOGRAPHY

- (1) *Methods of Analysis, A.O.A.C.*, 6th Ed., Sec. 12.2(b), p. 116 (1945).
- (2) *Ibid.*, Sec. 34.63, 34.64, and 34.65, p. 578-9.
- (3) BEVENUE, A., *Anal. Chem.*, 21, 586-587 (1949).
- (4) BEVENUE, A., and WASHAUER, B., *This Journal*, 33, 122-127 (1950).
- (5) HASSID, W. Z., *Ind. Eng. Chem., Anal. Ed.*, 8, 138-140 (1936).
- (6) HASSID, W. Z., *Ibid.*, 9, 228-229 (1937).
- (7) WILLIAMS, K. T., POTTER, E. F., BEVENUE, A., and SCURZI, W. R., *This Journal*, 32, 698-706 (1949).
- (8) WILLIAMS, K. T., BEVENUE, A., and WASHAUER, B., *This Journal*, 33, 986 (1950).

* For report of Subcommittee A and action of the Association, see *This Journal*, 34, 43 (1951).

REPORT ON COBALT AND COPPER IN PLANTS

By KENNETH C. BEESON (U. S. Plant, Soil, and Nutrition Laboratory, Bureau of Plant Industry, Soils, and Agricultural Engineering, A.R.A., U. S. Department of Agriculture, Ithaca, New York),
Associate Referee

At the last meeting of the Association it was recommended that the Associate Referee continue a collaborative study of the methods for cobalt and copper in plants (*This Journal*, 33, 41 (1950)). Before further collaborative work was undertaken, however, it seemed desirable to summarize the experience in this Laboratory in order to make certain revisions in the nitrosocresol method for cobalt essential to its wider use among analysts. This has been done, and the outline for the revised method is presented in the accompanying paper, "Some Modifications in the Ortho-nitrosocresol Method for Determination of Cobalt," by Gregory, Morris, and Ellis.*

It is recommended† that this method as revised be used for collaborative study of the determination of cobalt in plant tissue.

No reports were given on iodine and boron; carotene; sodium; cellulose and lignin; or pectin.

ANNOUNCEMENTS

REFEREE ASSIGNMENTS, CHANGES, AND ApPOINTMENTS

FISH AND OTHER MARINE PRODUCTS:

D. D. Price, Food and Drug Administration, Baltimore, Md., has been appointed as Associate Referee on Salt and Solids in Oysters.

GUMS IN FOODS:

M. J. GNAGY, Food and Drug Administration, Los Angeles, Calif., has been appointed as General Referee, in place of F. Leslie Hart.

SPICES AND OTHER CONDIMENTS:

A. F. Ratay, Food and Drug Administration, Cincinnati, Ohio, has been appointed as Associate Referee on Sampling and Preparation of Sample of French Dressing, to succeed A. Kramer.

* *This Journal*, page 710.

† For report of Subcommittee A and action of the Association, see *This Journal*, 34, 43 (1951).

CONTRIBUTED PAPERS

THE SPECTROPHOTOMETRIC ASSAY OF COMPLEX ANTIHISTAMINIC PREPARATIONS*

By DANIEL BANES (Division of Pharmaceutical Chemistry, Food and Drug Administration, Federal Security Agency, Washington, D. C.)

Preparations containing small quantities of antihistaminic compounds in combination with other drugs have appeared in commerce recently. Auxiliary drugs encountered have included autonomic bases, such as ephedrine, amphetamine, and naphazoline, local anesthetics of the tertiary amino-alkyl benzoate type, and alkaloids. The presence of these auxiliary amines would vitiate the titrimetric (1,2) and gravimetric (2,3) methods utilized for the assay of simple antihistaminic preparations, and many of them would also interfere in the general colorimetric methods proposed (4, 5).

Antihistaminic compounds absorb ultraviolet light, and spectrophotometric procedures based upon that property have been described (6, 7). Since all of the amines mentioned absorb light at the major wave lengths of maximum absorption observed for the antihistaminics, these methods could not be employed in their presence without modification. By the use of partition techniques it has been possible to develop spectrophotometric procedures readily adaptable for the determination of antihistaminics in a variety of mixtures.

EXPERIMENTAL

MATERIALS

The antihistaminic compounds studied included thonzylamine,¹ pyranisamine,² tripeleminamine,³ and methapyrilene⁴ of the ethylenediamine group; prophenpyridamine⁵ and chloroprophenpyridamine⁶ of the propylamine group; and doxylamine⁷ and diphenhydramine⁸ of the ethanolamine group. The following substances were employed in preparing tablet mixtures, elixirs, and cream preparations, to simulate actual or possible commercial products: ephedrine sulfate, amphetamine sulfate, naphazoline hydrochloride, benzocaine, butacaine sulfate, dibucaine hydrochloride, procaine hydrochloride, aminophylline, caffeine, phenacetin, and acetylsalicylic acid.

* Presented at the Annual Meeting of the Association of Official Agricultural Chemists, held at Washington, D. C., October 2-4, 1950.

- 1 Supplied by Nepera Chemical Co. as Neohetramine Hydrochloride.
- 2 Supplied by Merck and Co. as Neoantergan Maleate.
- 3 Supplied by Ciba as Pyribenzamine Hydrochloride.
- 4 Supplied by Monsanto as Thethylpyramine Hydrochloride.
- 5 Supplied by Schering Corp. as Trimeton and Chlortrimeton Maleate.
- 6 Supplied by Wm. S. Merrell Co. as Decapryn Succinate.
- 7 Supplied by Parke, Davis and Co. as Benadryl Hydrochloride.

SPECTROPHOTOMETRIC STUDY

For each antihistaminic substance, exactly 250 mg of the salt was dissolved in 50.0 ml of water. Aliquots of these stock solutions were then diluted with approximately 0.1 *N* sulfuric acid to yield solutions suitable for spectrophotometric measurement. For diphenhydramine hydrochloride a solution containing 25.0 mg of the salt in 100 ml of approximately 0.1 *N* sulfuric acid was employed; in all other cases the final solution contained 2.5 mg of the antihistaminic salt per 100 ml of dilute acid. Absorption spectra for these solutions between 230 and 400 $m\mu$ were determined by means of a Beckmann DU quartz spectrophotometer fitted with matched 1 cm quartz cells and a hydrogen lamp, using approximately 0.1 *N* sulfuric acid as reference solution. The spectra obtained were similar to those previously reported (1,3,6,7,8). Data pertinent to this investigation are summarized in Table 1.

TABLE 1.—Ultraviolet absorbancies of antihistaminics in 0.1 *N* acid solutions

ANTIHISTAMINE SALT	DISTINCTIVE λ_{max} , $m\mu$	EXTINCTION COEFFICIENT
Thonzylamine Hydrochloride	313	104
Methapyrilene Hydrochloride	315	269
Pyranisamine Maleate	314	196
Tripelennamine Hydrochloride	314	274
Propenpyridamine Maleate	265	212
Chloropropenpyridamine Maleate	264	219
Doxylamine Succinate	262	227
Diphenhydramine Hydrochloride	258	16.5

For a comparison of the spectrophotometric properties of antihistaminics isolated by extraction, with those of the pure salts, measured aliquots of the stock standard solutions were treated according to the three procedures described below:

Extraction Procedure A.—The aqueous solution of the antihistaminic salt was diluted to about 40 ml with water in a separatory funnel, rendered alkaline with 5 ml of 1 *N* sodium hydroxide solution, and extracted by shaking with 40 ml of U.S.P. ether. The alkaline layer was removed to a second separatory funnel and again extracted with 40 ml of ether. The process was then repeated in a third separatory funnel, and the alkaline layer discarded. The ether extracts in the three separatory funnels were then washed successively with two 20-ml portions of 0.1 *N* alkali, and one 20-ml portion of water. The base was extracted by shaking the ether solutions successively with two 20-ml portions and one 5-ml portion of 0.1 *N* sulfuric acid solution, and the acid extracts collected in a 50 ml volumetric flask. The combined extracts were diluted to volume with the dilute acid,

and mixed thoroughly. An aliquot equivalent to 6.25 mg of diphenhydramine hydrochloride, or 0.625 mg of the other salts, was diluted to exactly 25 ml with 0.1 *N* sulfuric acid solution.

Extraction Procedure B.-The aliquot containing the antihistaminic salt was diluted to 25 ml in a separatory funnel, acidified with 1 ml of (1+1) sulfuric acid solution, and washed by shaking with 40 ml of ether. The acidic solution was removed to another separatory funnel and again washed with 40 ml of ether, and the process was repeated a third time. The washed acidic extract was collected in a 50 ml volumetric flask. The ether solutions were extracted in succession with one 15-ml portion of water, and the combined aqueous extracts were diluted to exactly 50 ml for use in Procedures B1 and B2.

Extraction Procedure B1.-A convenient aliquot of the acidic solution was transferred to a separatory funnel, rendered alkaline with 1 *N* sodium hydroxide solution, diluted to 30 ml with water, if necessary, and extracted with 30 ml of chloroform. The chloroform was washed in a second separatory funnel containing 10 ml of water, and filtered through a pledget of cotton into a 100 ml volumetric flask. The process was repeated with three 20-ml portions of chloroform, and the combined extracts diluted to exactly 100 ml. An aliquot of the well-mixed solution containing 0.25 mg of antihistaminic salt (2.5 mg in the case of diphenhydramine hydrochloride) was placed in separatory funnel and the bases extracted by shaking vigorously with 10.0 ml of approximately 0.1 *N* sulfuric acid solution. The clear aqueous solution was examined spectrophotometrically.

Extraction Procedure B2.-An aliquot of the washed acidic solution containing 1.25 mg of the antihistamine salt (12.5 mg in the case of diphenhydramine hydrochloride) was rendered alkaline with 1 *N* sodium hydroxide solution, diluted to 30 ml with water, if necessary, and extracted with 30 ml of chloroform. The chloroform layer was then passed through two separatory funnels, each containing 20 ml of 0.1 *N* sulfuric acid solution, and finally discarded. The entire double-extraction process was repeated with three 20-ml portions of chloroform. The aqueous solutions were washed into a 50-ml volumetric flask with the dilute acid, and diluted to the mark to provide solutions suitable for spectrophotometric measurements.

The final acidic solutions obtained in the three extraction procedures exhibited ultraviolet spectra identical with those of the corresponding standard solutions, within the limits of error of the method, indicating quantitative recoveries in all cases. Use of varying concentrations of salts showed that all of the substances adhered to Beer's Law at the distinctive wave lengths of maximum absorption.

ANALYTICAL PROCEDURES

Ethylenediamine Group.-The secondary absorption peak in the vicinity of 310-315 $m\mu$, common to all members of the group in acidic solution, was

deemed the more advantageous for analytical purposes, since many extraneous substances which absorb strongly at the major peak (238-243 $m\mu$) are transparent above 300 $m\mu$. The following direct procedure yielded satisfactory results with preparations containing ephedrine, amphetamine, caffeine, acetylsalicylic acid, phenacetin, or benzocaine as interfering substance:

Transfer a convenient, representative portion of the mixture, containing 10-15 mg. of the antihistaminic salt, to a separatory funnel, and treat according to Extraction Procedure A above. (Procedure B1 may be preferable for creams). Compare the absorbancy of the final sample solution so obtained with that of the appropriate standard solution at 314 $m\mu$, and compute the concentration of the antihistaminic salt in the sample.

In the presence of procaine, Extraction Procedure B2 was used, except that the alkaline mixture was heated on the steam bath for thirty minutes prior to the first chloroform extraction. Procaine is readily hydrolyzed under these conditions, and the acidic product, which possesses all of the absorbancy above 300 $m\mu$, is retained by the alkali.

Amines like naphazoline, which absorb strongly in the 310-314 $m\mu$ region, require a more complicated treatment. In the case of naphazoline itself, a "two-color" analysis may be employed, and the method is especially suitable since the proportion of the antihistaminic to the naphazoline is usually high. The effect of the naphazoline may also be eliminated by the use of partition chromatography. The latter method is mandatory in the presence of bases like dibucaine, whose spectra resemble those of the ethylenediamine antihistaminics so closely that "two-color" analysis is infeasible. The procedure described below for prophenpyridamine was successfully modified for the separation of pyranisamine from dibucaine by using a 25 gm Celite-25 ml buffer column.

PI'ophenpyridamine, Chloroprophenpyridamine, and Doxylamine.-Although each of these bases absorbs strongly in the neighborhood of 263 $m\mu$, the possible interference of many other substances makes it necessary that further purification beyond the extraction processes be utilized. Chromatographic partition procedures have been employed in the separation of many groups of substances whose members resemble each other closely (9-12). Recently, Haenni (12) has described a method for the isolation of the various non-ketonic estrogens in pregnant mare's urine, by the use of a column in which dilute alkali adsorbed on Celite⁹ served as immobile solvent. Such a column can be adapted to the separation of basic substances. A 1.0 M solution of monobasic potassium phosphate (KH_2PO_4) adsorbed on Celite was found to constitute a convenient immobile phase for the isolation of prophenpyridamine, chloroprophenpyridamine, doxylamine, or pyranisamine, when chloroform was used as the mobile solvent. The columns were prepared according to the instructions of Haenni (12).

• Celite No. 545. Manufactured by Johns Manville Corp.

and determinations were performed upon chloroform solutions of mixed bases, employing the isolation method of process B1.

Preparation of the Partition Column.-Prepare a partition tube by fusing a 6 cm length of 5-6 mm tubing to a piece of 25 mm glass tubing about 200-300 mm in length. Constrict the stem slightly 2 cm below the joint. Flatten the end of a glass rod to a circular head with a clearance of about 1 mm in the partition tube, to serve as a packing rod. Insert a wad of fine glass wool in the stem of the partition tube, and fasten a piece of rubber tubing with attached screw clamp to the outlet to limit solvent flow during packing. Cover 10 gm of Celite in a mortar with chloroform, and distribute uniformly over the mixture 10 ml of 1.0 *M* monobasic potassium phosphate (KH_2PO_4) soln. Mix carefully with the pestle until the Celite appears to be uniform in particle size and wetness. Transfer about a fifth of the Celite mixture to the tube by means of a spatula, and form a flocculent suspension by working the packing rod up and down as a piston, adding chloroform, if necessary. Gently compress the Celite mixture with the rod to form a uniform pack about 1.5 cm high. Transfer the remainder of the Celite mixture to the partition tube in four portions, repeating the packing process with each. (The Celite must be covered with chloroform at all times.) Open the screw clamp and allow the chloroform to flow freely, marking the height of the chloroform head which yields a flow rate of 2.5-3.0 ml/min. Flow rate may be decelerated by the use of more glass wool packing. By means of a reservoir (a stoppered long-stemmed 500 ml separatory funnel is convenient) maintain this chloroform head during the course of the chromatographic partition. The rate of elution may vary with the temperature. Values reported in this study were obtained at a temperature of 27-29°C.

Determination of Antihistaminic Bases.-Suspend a portion of the sample containing 10-15 mg of the antihistamine salt in about 30 ml of water, and isolate the mixed bases as solute in 100 ml of chloroform soln by treating according to process B1. Pipette exactly 10 ml of the chloroform soln onto the column, and collect the eluates in a graduated cylinder. When the level of the chloroform solution just reaches the upper surface of the column, add 5 ml of chloroform. Repeat with a second 5-ml portion of chloroform. When the last washings subside, fill the tube to the mark, and add chloroform from the reservoir, maintaining a flow-rate of 2.5-3.0 ml/min. Discard the first 50 ml of forerun. Collect the next 250 ml of eluate in a volumetric flask and mix. Transfer exactly 50 ml of the eluate to a separatory funnel, shake vigorously with 10.0 ml of ca 0.1 *N* sulfuric acid soln, and separate the aqueous layer. Determine the absorbancy of the filtered soln at the appropriate wave length of maximum absorption, using the dilute acid as reference blank. Compare this value with that obtained with the corresponding standard soln, and compute the concentration of the antihistaminic salt in the sample.

The proposed method yielded satisfactory results when applied to preparations containing prophenpyridamine or doxylamine (Table 2). A column prepared with 20 gm of Celite and 20 ml of buffer solution was required for the analysis of mixtures containing chloroprophenpyridamine; Pyranisamine mixtures could be partitioned by the use of 25 gm Celite-25 ml buffer columns, although such conditions represent the limit of utility for the column, and other buffers or solvents may be preferable.

Special Method for Diphenhydramine.-The adsorption properties of diphenhydramine made it difficult to separate the substance from weakly basic impurities readily, and it was necessary to devise a more specific

TABLE 2.—The assay of antihistaminic preparations

ANTIHISTAMINIC	PUT IN	RECOVERED	RECOVERY	AUXILIARY DRUGS	TYPE OF PREPARATION	ANALYTICAL PROCEDURE
Thonzylamine Hydrochloride	mg. 50	mg. 49.1	per cent 98.2	mg. Acetylsalicylic Acid 220 Caffeine 32 Phenacetin 160	Tablet	Direct
	50	49.1	98.2	Ephedrine Sulfate 140 Aminophylline 370	Elixir	Direct
	50	48.4	96.8	Procaine Hydrochloride 140	Cream	Hydrolysis
Methapyrilene Hydrochloride	25	24.9	99.6	Acetylsalicylic Acid 220 Caffeine 32 Phenacetin 160	Tablet	Direct
	25	24.7	98.8	Benzocaine 120 Procaine HCl 160	Cream	Hydrolysis
Tripeleminamine Hydrochloride	25	25.3	101.2	Acetylsalicylic Acid 220 Caffeine 32 Phenacetin 160	Tablet	Direct
	25	24.8	99.2	Naphazoline Hydrochloride 25	Saline Solution	"Two-Color"
Pyranisamine Maleate	25	24.9	99.6	Ephedrine Sulfate 150 Aminophylline 200	Elixir	Direct
	10	10.1	101.0	Dibucaine Hydrochloride 30	Cream	Chromatographic Partition
Prophepyridamine Maleate	12.5	12.3	98.4	Benzocaine 120 Butacaine Sulfate 100	Cream	Chromatographic Partition
Doxylamine Succinate	12.5	12.4	99.2	Amphetamine Sulfate 40 Naphazoline Hydrochloride 100	Saline Solution	Chromatographic Partition
Chloroprophenyridamine Maleate	10	9.7	97.0	Acetylsalicylic Acid 220 Caffeine 32 Phenacetin 160	Tablet	Chromatographic Partition
	10	9.6	96.0	Ephedrine Sulfate 50 Aminophylline 150	Elixir	Chromatographic Partition
Diphenhydramine Hydrochloride	12.5	12.8	102.4	Naphazoline Hydrochloride 20 Amphetamine Sulfate 40	Saline Solution	Special Method
	12.5	12.9	103.2	Ephedrine Sulfate 65 Aminophylline 70	Elixir	Special Method
	12.5	12.2	97.6	Acetylsalicylic Acid 220 Caffeine 32 Phenacetin 160	Tablet	Special Method
	12.5	12.4	99.2	Benzocaine 30 Dibucaine Hydrochloride 12.5	Cream	Special Method

procedure for its determination. The substance is quantitatively split into a neutral fragment and an amine fragment when heated with moderately strong acid. The neutral product could be isolated from basic substances and compared spectrophotometrically with standards for assay purposes. This procedure permitted an accurate estimation of diphenhydramine in the presence of ephedrine, amphetamine, naphazoline, aminophylline, caffeine, phenacetin, acetylsalicylic acid, benzocaine, or dibucaine:

Transfer a portion of the sample, containing 10–15 mg of diphenhydramine hydrochloride to a separatory funnel, and treat according to Extraction Procedure A, collecting the acidic extracts in a suitable flask. Add 10 ml of (1 + 1) sulfuric acid, and boil under a reflux condenser for 15 min. (Transfer an aliquot of standard diphenhydramine hydrochloride soln containing exactly 12.5 mg of the salt to a flask, dilute to about 50 ml, add 10 ml of (1 + 1) sulfuric acid, and hydrolyze and extract as in the case of the sample.) Cool, transfer to a separatory funnel, and rinse the flask with 20 ml of chloroform in several small portions, collecting the washings in the separatory funnel. Shake vigorously, separate the chloroform layer, and transfer it to a separatory funnel containing 30 ml of 1 *N* sodium hydroxide soln. Shake, separate the lower layer, and wash in another separatory funnel by shaking with 30 ml of water. Filter thru a cotton pledget moist with chloroform into a 50 ml volumetric flask. Repeat the extraction process with two further 10 ml portions of chloroform, and dilute the combined extracts to exactly 50 ml with the solvent. Determine the absorbancies of the sample and the treated standard at 259 $m\mu$, using chloroform as the reference blank. It is essential that the same chloroform be used in the sample and standard extractions and for the blank. Compute the diphenhydramine content of the sample. Standard and sample solus should exhibit identical ultraviolet absorption spectra.

DISCUSSION OF ANALYTICAL RESULTS

Recoveries obtained by the use of the suggested procedures ranged from 96 to 103% of the put-in values (Table 2). The lower recoveries may be due in part to mechanical losses during extraction, and might be improved by subjecting a known standard to the same manipulations. The methods appear to be equally accurate when applied to tablets, elixirs, or creams.

Spectrophotometric methods are flexible, and may be adapted for use with larger, or smaller samples than those mentioned. Furthermore, the ultraviolet spectra and the chromatographic properties of isolated substances can be utilized in their positive identification, providing a qualitative as well as a quantitative determination. Thus, a minute quantity of purified prophenpyridamine could be distinguished from chloroprophenpyridamine on the basis of its behavior on the monobasic potassium phosphate column, by analyzing consecutive portions of chloroform eluate spectrophotometrically, and comparing with the properties of the known substances.

CONCLUSIONS

(1) Procedures have been suggested for the spectrophotometric determination of antihistaminic substances in the presence of other amines.

(2) The methods appear to be applicable to complex pharmaceuticals containing these substances.

BIBLIOGRAPHY

- (1) "New and Non-Official Remedies," pp. 611, 638, 683, J. B. Lippincott Co., Philadelphia, Pa., 1949.
- (2) HEIM, H. C., *This Journal*, 33, 199 (1950).
- (3) "New and Non-Official Remedies," p. 685.
- (4) GELVIN, E. P., MCGAVAK, T. H., and DREKTER, I. J., *Bull. N. Y. Med. Coll., Flower and Fifth Ave. Hosp.*, 9, 51 (1946).
- (5) BANDELIN, F. J., SLIFER, E. D., and PANKRATZ, R. E., *J. Am. Pharm. AS8n.*, 39, 277 (1950).
- (6) ANDERSON, L. T., GAKENHEIMER, W. C., ROSENBLUM, C., and SMITH, E. H., *Ibid.*, 38, 373 (1949).
- (7) MARTIN, E. W., and HARRISSON, J. W. E., *Ibid.*, 39, 390 (1950).
- (8) STORMONT, R. T., *J. Am. Med. A88n.*, 142, 816 (1950).
- (9) MARTIN, A. J. P., and SYNGE, R. L. M., *Biochem. J.*, 35, 1358 (1941).
- (10) RAMSEY, L. L., and PATTERSON, W. I., *This Journal*, 28, 644 (1945).
- (11) MARVEL, C. S., and RANDS, R. D., JR., *J. Am. Chem. Soc.*, 72, 2642 (1950).
- (12) HAENNI, E. O., *J. Am. Pharm. AS8n., This Journal*, 34, 86 (1951).

SOME MODIFICATIONS IN THE ORTHO-NITROSOCRESOL
METHOD FOR THE DETERMINATION OF COBALT*

By RICHARD L. GREGORY, CLAYTON J. MORRIS, and GORDON H. ELLIS (U. S. Plant, Soil, and Nutrition Laboratory, Bureau of Plant Industry, Soils, and Agricultural Engineering, A. R. A., U. S. Department of Agriculture, Ithaca, New York)

o-Nitrosophenol prepared by the "B reaction" of Baudisch (1, 2) was utilized by Cronheim (3) as a reagent for the colorimetric determination of cobalt. A similar reagent, o-nitrosocresol, was used by Ellis and Thompson (5) in a method adapted for use with biological materials. This reagent forms colored complexes with a number of metallic ions (CuII, FeI, FeII, COII, ZnII, HgII, and PdIII). Only the complexes of FeII, PdIII, and COII are appreciably soluble in Skellysolve B. Since palladium is not found in plant materials in measurable quantities it is necessary only to eliminate interference by iron to render this reagent completely specific for cobalt. This is most satisfactorily done by extracting the cobalt as the dithizonate with carbon tetrachloride from a solution buffered with ammonium citrate at pH 8.5, the iron remaining in the aqueous phase.

Extensive use of o-nitrosocresol for the determination of cobalt in plant

* Presented at the Annual Meeting of the Association of Official Agricultural Chemists, held at Washington, D. C., October 2-4, 1950.

samples during the past five years has led to certain modifications in the procedure. Although no fundamental changes have been introduced these modifications lead to a considerable saving in time. For the sake of convenience the revised method is presented in detail. Solutions of the tissue are prepared in such a way that a number of other elements can be determined on the same sample (6).

REAGENTS

(Make all distillations in Pyrex glass stills with ground glass joints. Store reagents in glass-stoppered Pyrex bottles.)

a. *Redistilled water.*-Distill twice, or pass thru a column of an ion-exchange material (IR-100A or equivalent) to remove heavy metals.

b. *Hydrofluoric acid*, reagent grade, 48%.-Procurement in vinyl plastic bottles, now available commercially, is advantageous. These alleviate danger in handling and the screw cap minimizes the contamination hazard.

c. *Perchloric acid*, reagent grade, 60%.-No further purification necessary.

d. *Hydrochloric acid*, 1:1.-Add an equal volume of reagent grade concentrated HCl to distilled water and distill.

e. *Ammonium hydroxide*, 1:1.-Distill concentrated NH_4OH into an equal volume of redistilled water.

f. *Ammonium hydroxide*, 0.02 N.-Add 7 ml of NH_4OH (1:1) to 2.5 liters of redistilled water.

g. *Carbon tetrachloride.*-Distill over CaO, passing the distillate thru an acid-washed filter paper.

h. *Dithizone.*-Dissolve 0.5 g of dithizone in 600-700 ml CCl_4 (technical grade is satisfactory). Filter into a 5 liter separatory funnel containing 2.5-3.0 liters of 0.02 N NH_4OH , shake well, and discard the CCl_4 layer. Shake with 50 ml portions of redistilled CCl_4 until the CCl_4 phase as it separates has a pure green color. Add 1 liter of redistilled CCl_4 and acidify slightly with distilled 1:1 HCl. Shake the dithizone into the CCl_4 layer and discard the water layer. Store in a cool dark place, preferably a refrigerator.

i. *Ammonium citrate soln*, 40%.-Dissolve 800 g citric acid in 600 ml of distilled water, and while stirring add slowly 900 ml of concentrated NH_4OH . The reaction is exothermic and care must be taken to prevent splattering. Adjust the pH to 8.5 if necessary. Dilute to 2 liters and extract with 25 ml portions of dithizone soln until the aqueous phase stays orange-colored and the CCl_4 remains predominantly green. Then extract the soln with CCl_4 until all of the orange color is removed.

j. *Phenolphthalein.*-Dissolve 1 g in 100 ml of distilled 95% ethanol.

k. *0.1 N Hydrochloric acid.*-Dilute 16.6 ml of 1:1 HCl to 1 liter with redistilled water.

l. *0.01 N Hydrochloric acid.*-Dilute 100 ml of 0.1 N HCl to 1 liter with redistilled water.

m. *N Sodium hydroxide soln.*-Dissolve 40 g of reagent grade NaOH in 1 liter of redistilled water.

n. *Sodium borate buffer*, pH 7.8.-Dissolve 20 g of boric acid in 1 liter of redistilled water. Add 50 ml of N NaOH and adjust the pH if necessary. Equal volumes of sodium borate buffer and 0.01 N HCl should give a soln of pH 7.0.

o. *Sodium borate buffer*, pH 9.1.-To 1 liter of the sodium borate buffer, pH 7.8, add 120 ml of N NaOH and adjust the pH if necessary.

p. *Skellysolve B.* (Skelly Oil Company, Chicago, Ill.).-Purify by adding 20-30 g of silica gel (Davison Chemical Company, Baltimore Md.) per liter and let stand for several days, then distill.

q. *Cupric acetate.*-Dissolve 10 gm of reagent grade cupric acetate in 1 liter of redistilled water.

r. *o-Nitrosocresol.*-Dissolve 8.4 g of anhydrous cupric chloride and 8.4 g of hydroxylamine hydrochloride in 900 ml of distilled water. Add 8 mlm-cresol (Eastman Kodak Company, practical grade) and stir vigorously while 24 ml of 30% H_2O_2 is added slowly. Stir with a motor-driven stirrer for two hours at room temp. (Standing for longer periods results in excessive decomposition.) Add 25 ml of concentrated HCl and extract the *o*-nitrosocresol with four successive 150 ml portions of Skellysolve B in a large separatory funnel. Then add an additional 25 ml of concentrated HCl and again extract with four 150 ml portions of Skellysolve B. Wash the combined Skellysolve B extracts twice with 50-100 ml portions of 0.1 *N* HCl and twice with 50-100 ml portions of redistilled water. Shake the soln of *o*-nitrosocresol with successive 50-100 ml portions of 1% cupric acetate until the aqueous phase is no longer deep blood-red. When a light purple color is evident, extraction is complete. Discard the Skellysolve B phase, acidify the aqueous soln of the cupric salt with 25 ml of concentrated HCl, and extract the reagent with two successive 500 ml portions of Skellysolve B; wash by shaking with two 150-200 ml portions of 0.1 *N* HCl and several 150-200 ml portions of redistilled water. Store the soln of *o*-nitrosocresol in a refrigerator at ca 4°C. This reagent is stable for six months or more.

s. *Sodium o-nitrosocresol.*-Extract 100 ml of the *o*-nitrosocresol soln by shaking with two successive 50 ml portions of the sodium borate buffer, *pH* 9.1, in a separatory funnel. If this is carried out as two extractions, the resulting reagent is more concentrated. It is important that the total volume of *o*-nitrosocresol soln equals the total volume of buffer.

t. *Cobalt standard soln.*-Prepare a stock soln containing 100 micrograms per ml of Co by heating $CoSO_4 \cdot 7H_2O$ in an oven at 250°-300°C. to constant weight (6-8 hours). Weigh exactly 0.263 g of the $CoSO_4$ and dissolve in 50 ml of redistilled water and 1 ml of C.P. concentrated H_2SO_4 . Make to a volume of 1 liter. Transfer 5 ml of the stock soln to a 1 liter volumetric flask and dilute to volume with redistilled water. This soln contains 0.5 micrograms Co per ml and is used as a working standard.

u. *Hydroxylamine acetate buffer, pH 5.1.*-Dissolve 10 g of C.P. hydroxylamine hydrochloride and 9.5 g of C.P. anhydrous sodium acetate in 500 ml of redistilled water. The resulting soln will have a *pH* of 5.0-5.2.

SPECIAL EQUIPMENT

a. *Platinum dishes* of ca 70 ml capacity are used for ashing the plant material.

b. *Automatic dispensing burettes*, 100 ml capacity, of a type that can be fitted to an ordinary 5 lb reagent bottle and that can be filled by means of an aspirator bulb are most convenient. In this way reagents are very seldom exposed to contamination. Speed of manipulation is also measurably increased.

c. A *wooden separatory funnel rack* for holding twelve 120 ml separatory funnels is convenient for the dithizone extractions. The rack is fitted across the top with a removable bar padded with sponge rubber to make it possible to shake all twelve separatory funnels as a unit.

d. *Racks* consisting of two 2" X 2" X 25" wooden bars with holes drilled at close intervals to take 50 ml centrifuge tubes fitted with No. 13 standard taper glass stoppers will also prove to be convenient. These tubes are made by reaming out the neck of Pyrex heavy walled centrifuge tubes (Rockefeller Institute of Medical Research type) with a standard taper carbon rod and grinding to take a standard taper stopper. The tubes are placed upright in one section, and the other (fitted with sponge rubber discs $\frac{1}{2}$ " in thickness in the bottom of the holes) is placed across their tops. The two sections are fastened at the ends with removable rubber con-

nectors made from ordinary tubing of a convenient size. This makes it possible to shake any number of tubes as a unit. These tubes are utilized for the reaction of cobalt with nitrosocresol, the extraction of the complex into Skellysolve B, and washings of the Skellysolve B soln.

e. *Shaking machine.* A commercial mechanical shaker similar to Model L-2549 in Catalogue G-3 of the George H. Wahmann Manufacturing Company of Baltimore, Md., is satisfactory when modified to give a longitudinal stroke of two inches at a rate of ca 180 strokes per min. This shaker is used in making dithizone extractions, and in the extraction of the cobalt complex.

f. *Colorimeter.* The colorimeter found to be most satisfactory for this work is described by Ellis and Brandt (4). The Coleman Model 11 Spectrophotometer can be used for the cobalt determination. A wave length of ca 345 m μ , using the null-point method, is most satisfactory. With this instrument, the calibration curve deviates slightly from linearity, probably because of the impurity of the light band. However, the region of the curve between 0 and 1 mmg of Co approaches very close to a straight line. A pair of matched Pyrex glass absorption cells at least 5 cm in length is required. A satisfactory cell is made by the American Instrument Company, Silver Springs, Maryland (Catalogue No. 5-997). Style D (horizontal) with neck for cork or rubber stopper is recommended. The outside diameter is 13 mm and the length 5 cm. The capacity is about 3 ml.

CLEANING OF GLASSWARE

The 120 ml Pyrex separatory funnels used for dithizone extractions are initially cleaned by soaking for 30 minutes in hot concentrated HNO₃ and rinsing several times with distilled water. As an added precaution, shake with several portions of dithizone in CCl₄. After use, cleaning is accomplished by rinsing with distilled water, draining, and stoppering to avoid contamination. It is not necessary to clean every time with the acid. The HNO₃ cleaning should be repeated, however, if the blanks are unusually high.

The 50 ml glass-stoppered Pyrex centrifuge tubes are cleaned by soaking for 30 minutes in C.P. concentrated HNO₃ followed by several rinsings in distilled water.

Pipettes are completely submerged in a cylinder of sulfuric acid-potassium dichromate cleaning solution overnight and then rinsed several times with distilled water before suspending upright in a rack to dry.

All other glassware is washed thoroughly in detergent and rinsed well with tap water followed by a dipping in sulfuric acid-potassium dichromate cleaning solution. The cleaning solution is rinsed off with tap water followed by several distilled water rinses.

Platinum is cleaned by scrubbing with sea sand followed by boiling in 10% HCl for 30 minutes. It is then rinsed with distilled water several times.

PREPARATION OF SAMPLE

All plant material is first oven-dried for 48 hours. It is then prepared for ashing by either of the following methods:

(1) Grind the material in a Wiley mill equipped with a stainless steel sieve. Thoroughly mix the material by rolling, and sample by quartering.

(2) Cut the material by hand fine enough for convenient subsequent sampling using stainless steel shears.

ASHING OF SAMPLES

Weigh 6 g of the dry plant tissue into a clean platinum dish. Cover with a Pyrex watch glass, and place in a cool muffle; heat slowly to 500°C. for overnight. Remove the sample and cool. Wet down the ash carefully with a fine stream of redistilled water. From a dispensing burette add slowly 2-5 ml HClO., dropwise at first to prevent spattering. Add ca 5 ml H.F*. Place on a steam bath to evaporate slowly. Transfer to a sand bath and maintain at medium heat until fuming ceases. Cover with a Pyrex watch glass and return to the partially cooled muffle and heat gradually to 600°C. Allow to remain at this temp. for one hour. Remove the sample and cool. Add 5 ml of 1:1 HCl and about 10 ml of redistilled water. Replace the cover glass and warm on a steam bath to effect solution. Usually a clear soln essentially free of insoluble material is obtained. Transfer the sample to a 50 ml volumetric flask, washing the dish several times with redistilled water, and dilute to volume. Mix thoroly to insure a homogeneous soln. Platinum dishes can ordinarily be used several times between sand and acid cleanings.

DITHIZONE EXTRACTION

Transfer a suitable sized aliquot (2-3 g dry material) to a 120 ml separatory funnel (use vaseline as a stopcock lubricant). Add 5 ml of 40% ammonium citrate soln. Add one drop of phenolphthalein and adjust to pH 8.5 with 1:1 NH.OH. If a precipitate forms at this stage, add additional ammonium citrate. Add 10 ml of dithizone in CCl. and shake for 5 min. Draw off the CCl. phase into a 100 ml beaker. Repeat as many times as is necessary using 5 ml quantities of dithizone soln and shaking for 5 min each time. The extraction is complete when the aqueous phase remains orange and the CCl. phase remains predominantly green in color. Then add 10 ml of CCl₄, shake for 5 min, and combine with the CCl₄ extract. The final 10 ml of CCl. should be pure green in color. If not, extraction was incomplete and must be repeated. Add 2 ml of HClO, to the combined CCl. extracts, cover the beaker with a Pyrex watch glass, and digest on a hot plate until colorless. Remove the cover glass and evaporate slowly to dryness. If the sample is heated for any length of time at a high temp. after coming to dryness, losses of Co may occur. Heat only enough to completely evaporate to dryness. If free acid remains it will interfere with the next step where pH control is important. Add 5 ml of 0.01 N HCl to the residue. Heat slightly to assure soln and transfer to a 50 ml glass-stoppered centrifuge tube or to a 60 ml separatory funnel with redistilled water.

DETERMINATION OF COBALT

Add 5 ml of sodium borate buffer, pH 7.8, to the sample and 2 ml of freshly prepared sodium o-nitrosocresol soln. Add exactly 5 ml of Skellysolve B and shake for 10 min. Remove the aqueous phase by moderate suction thru a finely-drawn glass tube. To the Skellysolve B add 5 ml of 1% aqueous cupric acetate and shake for one min to remove excess reagent. Again remove and discard the aqueous phase. Wash the Skellysolve B by shaking for one min with 5 ml of redistilled water, removing the aqueous layer as before; finally, shake the Skellysolve B with 5 ml of hydroxylamine-acetate buffer for one min to reduce the iron. Transfer the Skellysolve B soln of the cobalt complex to a 5 cm absorption tube and read in a photoelectric colorimeter using Corning standard thickness filters No. 5860 and 4308, or a light band as close as possible to the point of maximum absorption, 360 mμ.

BLANKS AND STANDARDS

With each set of determinations an ashing blank, a reagent blank, and an appropriate standard curve are included. Since the Lambert-Beer law holds for the Co-o-nitrosocresol complex, the three points--0.0 micrograms (reagent blank), 0.5 micrograms, and 1.0 micrograms--are sufficient to define the standard curve. The per cent transmission of the 0.0 microgram point should never drop below 90%. If it drops below this level the o-nitrosocresol should be repurified by alternately transferring to the aqueous phase as the copper salt and to the Skellysolve B phase as the free compound following acidification of the aqueous phase. The ashing blank should have a transmission reading not more than 2 or 3 per cent lower than the reagent blank.

It is also advisable to include a standard sample with each set of samples to detect contamination or unusual losses of cobalt in the procedure. A commercial buckwheat flour containing 0.05 p.p.m. of Co has proven satisfactory for this purpose.

CALCULATIONS

Results are expressed in terms of parts per million of cobalt and are based upon the dry weight of the sample. A simple formula to express the relationship of the various factors involved follows:

$$\frac{\text{Total volume of solution in ml}}{\text{Dithizone aliquot in ml}} \times \frac{\text{micrograms of Co}}{\text{Dry weight of sample in grams}} = \text{Parts per million.}$$

The value for micrograms of cobalt is that obtained from the standard curve less the ashing blank.

DISCUSSION

Although 2-3 gram of dry material is sufficient for most samples, it is advisable to ash a larger sample (thus reducing the sampling error) and take an aliquot of the resulting solution for analysis.

The dithizone extraction of the solution of plant material, buffered with ammonium citrate at *pH* 8.5, separates cobalt, copper, and zinc from such elements as iron, phosphorus, manganese, calcium, and molybdenum. The cobalt, copper, and zinc complexes are dissolved in the carbon tetrachloride phase. Zinc could be removed by a subsequent acid dithizone extraction. However, 500 micrograms of zinc will not affect the determination of cobalt. Furthermore, as much as 1000 micrograms of copper will not interfere with the cobalt determination even in the presence of as little as 2 ml of sodium o-nitrosocresol.

To test the completeness of the dithizone extraction, cobalt solutions containing 0, 0.5, and 1.0 micrograms of cobalt were extracted with dithizone. In like manner a second set of solutions was run without dithizone extraction. The cobalt recovered in similar solutions in the two sets was identical.

To insure the validity of the color criterion (orange for the aqueous phase and green for the carbon tetrachloride phase) as an indication of complete extraction, additional dithizone and carbon tetrachloride extracts were made subsequent to this point and cobalt was determined on

these extracts. In all cases no cobalt was detectable in the second extracts.

The method for the preparation and storage of the o-nitrosocresol reagent given here is somewhat different from that previously described (5). The yield is greater and the reagent has been found to be more stable when stored in the free form in Skellysolve B than when stored as the aqueous copper salt.

Often a flocculent red precipitate appears at the interphase when the cobalt o-nitrosocresol complex is extracted into Skellysolve B. This can be attributed to the presence of zinc. It in no way interferes with the subsequent determination of cobalt, and is removed on shaking with 1% aqueous cupric acetate.

It is important to realize that this procedure is designed to determine extremely small quantities of cobalt and involves many physical operations. Therefore it is not too surprising to find that several sets of analyses may be necessary before the procedure is well in hand. Many wholly competent analysts have encountered initial difficulties which soon resolve themselves. In view of the low levels of cobalt present, every conceivable precaution against contamination must be taken. The prevention of contamination from poorly-cleaned glassware or reagents during manipulation is a technique that must be acquired through practice.

SUMMARY

A method for the determination of cobalt in plant materials is presented. It is based on the nitrosocresol method of Ellis and Thompson (5). Certain changes and details are described which make for greater convenience, particularly when used for a large number of samples.

REFERENCES

- (1) BAUDISCH, O., *Jour. Am. Chem. Soc.*, 63, 622 (1941).
- (2) —, *Science*, 92, 336 (1940).
- (3) CRONHEIM, G., *Ind. Eng. Chem., Anal. Ed.*, 14, 445 (1942).
- (4) ELLIS, G. H., and BRANDT, C. S., *Anal. Chem.*, 21, 1546-8 (1949).
- (5) —, and THOMPSON, J. R., *Ind. Eng. Chem., Anal. Ed.*, 17, 254 (1945).
- (6) PARKS, R. Q., HOOD, S. L., HURWITZ, CHARLES, and ELLIS, G. H., *Ibid.*, 15, 527 (1943).

RAPID ASSAY FOR NITROGLYCERIN TABLETS*

By JAMES H. CANNON and RICHARD F. HEUERMANN (Food and Drug Administration, Federal Security Agency, St. Louis, Mo.)

Clark (1) has pointed out the economy of time and effort in micro-scale operations. The assay described here is a small scale operation and has some of the attractive features discussed by Clark. The sample required is relatively small (about one-sixth the amount used in the A.O.A.C. method (2)). The apparatus is rugged and simple and the time

required to complete an assay is about one-third that required by the A.O.A.C. method.

METHOD

APPARATUS

- (a) 100 ml round bottom flask with 24/40 standard taper neck and 3 ft. air condenser to fit.
- (b) 50 ml Erlenmeyer flask.
- (c) Connecting tube (see Fig. 1).

REAGENTS

- (a) *Sulfuric acid*, 0.01 *N*.
- (b) *Powdered Devarda's alloy*.
- (c) *Alcoholic potassium hydroxide*, ca 0.5 *N*.

PREPARATION OF SAMPLE

Determine the average weight per tablet and grind about 20 tablets to a fine powder. Transfer a weighed portion of the powdered material representing about 5 mg of nitroglycerin to a separatory funnel.¹ Add about 25 ml of H₂O and extract three times with 25 ml portions of ether. Transfer the ether extracts directly to the 100 ml round bottom flask. Add 10 ml of the alcoholic KOH soln and place the air condenser in the flask. Place the flask on a steam bath in a hood and allow the ether to distill off thru the air condenser. Cool the flask and remove the air condenser.

DETERMINATION

Place 5 ml of H₂O and 3 drops of methyl red indicator in the 50 ml Erlenmeyer flask. Add 10 ml alcohol and 50-100 mg of powdered Devarda's alloy to the 100 ml round bottom flask containing the nitroglycerin extract. Immediately connect the two flasks with the connecting tube (see Fig. 1). Place the 50 ml flask in an ice water bath and apply heat gradually to the 100 ml flask to bring to a gentle boil. (A small electric heater is easier to control than a flame.) Distill until nearly all of the alcohol has passed over into the chilled 50 ml flask. Discontinue the distillation rinse the tip of the delivery tube with water and titrate immediately with 0.01 *N*

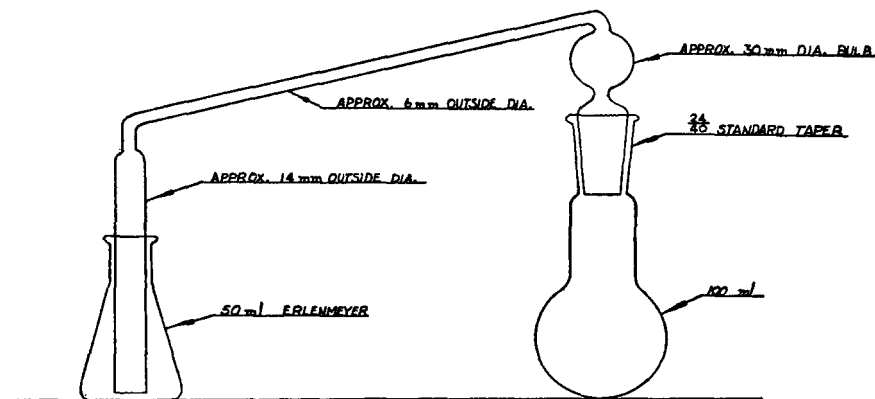

Fig. 1.-Connecting tube.

¹ To minimize transfer losses the ether separatory funnel described in *This Journal*, 33, 934 (1950) may be used.

TABLE I.-ResuUs 01 assays *made* on commercial sample8
01 nitroglycerin table8

(A) $\frac{1}{100}$ grain tablet triturates		
ANALYST	A.O.A.C. METHOD MG/TABLET	RAPID ASSAY MG/TABLET
1		0.556 0.546
2	0.544 0.538 0.584	0.556 0.551
3		0.561 0.561
4		0.562 0.560
		Mean value 0.5566; Standard deviation from mean, 0.0051 mg or 0.92%
(B) $\frac{1}{150}$ grain hypodermic tablets		
1	0.435 0.443	0.432 0.436
2		0.432 0.436
3		0.441 0.436
4		0.412 0.436 0.432 0.436 0.436
		Mean value 0.4332; Standard deviation from mean, 0.0078 mg or 1.80%

H₂SO₄ soln. Each 1 ml of 0.01 *N* H₂SO₄ soln is equivalent to 0.757 mg of nitroglycerin. A blank determination should be made on a given set of reagents, and the blank titration, if any, should be subtracted from the sample titration.

DISCUSSION

The rapid assay differs in two important respects from the A.O.A.C. method (2) for nitroglycerin tablets. First, the distillation of the ammonia is made with alcohol instead of water, and secondly, the ammonia is absorbed in ice water instead of standard acid. There are two advantages in using alcohol as a distilling medium. Frothing is eliminated and blank titrations are reduced to a negligible value. The absorption of the ammonia in ice water eliminates the need for the standard sodium hydroxide solution and ammonia is titrated directly with standard acid.

The feasibility of these two steps was tested first by assaying a "known" solution of sodium nitrite in alcohol. The solution was prepared from pure sodium nitrite and was assayed as follows:

A 10 ml aliquot was placed in the 100 ml distilling flask and 10 ml of alcoholic potassium hydroxide solution was added. 50 mg of powdered Devarda's alloy was added and the distillation was made as directed above under Determination. Titration values on 18 assays are shown in Table 2.

TABLE 2.-*Assay of sodium nitrite solution*

ANALYST	NaNO ₂ ; THEORETICAL AMT. IN ALIQUOT	NaNO ₂ FOUND IN ALIQUOT
1	mg	mg
	6.90	6.85
	6.90	6.85
	6.90	6.83
	6.90	6.83
	6.90	6.81
	6.90	6.83
	6.90	6.83
	6.90	6.82
2	6.90	6.81
	6.90	6.83
	6.90	6.83
	6.90	6.85
5	6.90	6.81
	6.90	6.83
	6.90	6.83
	6.90	6.83
	6.90	6.83
		Mean value 6.83; Standard deviation from mean 0.011 or 0.16%

The consistently good recoveries and low deviations from the mean indicate the practicability of this procedure for determining the evolved ammonia.

SUMMARY

The rapid assay described in this paper can be completed in about one-third the time required by the A.O.A.C. method. Only about one-sixth the amount of sample is required. The ether extract of nitroglycerin is never transferred from one vessel to another, but is evaporated, hydrolyzed, reduced, and distilled in the same flask. The use of alcohol as a distilling medium eliminates frothing. Blank titrations are unusually low and are constant for a given batch of reagents.

ACKNOWLEDGMENT

The authors are indebted to Mary A. McEniry, H. E. Theper, and Jean Mansur of this laboratory for collaborative analytical work.

REFERENCES

- (1) CLARK, E. P., *This Journal*, 16, 255 (1933).
- (2) *Methods of Analysis A.O.A.C.* 7th Ed. Sec. 32.171.

EFFECT OF NEUTRALIZATION OF CREAM IN THE MANUFACTURE OF BUTTER ON WATER-INSOLUBLE FATTY ACIDS AND BUTYRIC ACID

By FRED HILLIG,¹ S. W. AHLMANN,² and R. C. JORDAN³ (Food and Drug Administration, Federal Security Agency, Washington 25, D. C.)

In previous communications^{1,2} methods were described for the determination of water insoluble fatty acids (WIA) and butyric acid in cream and butter. Application of these two methods has been made to the study of progressive decomposition in cream.^{2,3} In another paper⁴ data were presented on the determination of WIA in butters from 113 authentic churns prepared on a commercial scale including 23 churns of sweet cream.

This investigation was conducted to study the effect of neutralization followed by pasteurization on WIA and butyric acid in cream and butter. The work was conducted in creameries located in the middle West. The cream was produced in the States of Ohio, Indiana, West Virginia, Illinois, Kentucky, Tennessee, Arkansas, and Missouri. As in a previous study⁴ the classification of cream proposed by Vandaveer and Wildman⁶ was

¹ Division of Food, Food and Drug Administration.

² Cincinnati District, Food and Drug Administration.

³ St. Louis District, Food and Drug Administration.

⁴ *This Journal*, 30, 575 (1947).

⁵ *Ibid.*, 31, 750 (1948).

⁶ *Ibid.*, 32, 731 (1949).

⁷ *Ibid.*, 31, 739 (1948).

⁸ *Ibid.*, 23, 693 (1940).

used. For the convenience of the reader in reviewing the data the four classes of cream are repeated here.

- (0) Cream which is either sweet or good clean sour; sound cream which a discriminating housewife would use for butter making in her own kitchen.
- (1) Cream which has an indefinite or indefinable "off" flavor or odor (*e.g.*, due to feeds).
- (2) Cream in which a decomposition characteristic ("cheesiness," rancidity, putridity, etc.), is strong enough to be definitely recognizable.
- (3) Cream in which the flavor characteristics of decomposition are markedly stronger than creams classified as (2).

As in previous studies with authentic churns of cream, each individual can of cream entering into each churn was classified and the percentage of each class in the churn was computed. The normal routine of the creamery was not changed; the creamery employees prepared the churns in their customary manner. The composition of the commercial neutralizers used by the creameries where the churns were prepared, as well as the temperatures employed during neutralization, are given in Table 1.

TABLE 1.-*Composition of commercial neutralizers*

NEUTRALIZER NUMBER	COMPOSITION	TEMPERATURE USED IN NEUTRALIZATION
1	NaOH-Na.CO.	11D-120°F
2	Na.CO., NaHCO.	110°F
3	NaHCO.-Na.CO., finished with lime in the cold	90°F
4	Lime	90-100°F
5	Na.CO.	90-100°F
6	Lime followed by NaOH	SO-90°F

For each churning, the cream in the vat was sampled both before neutralization and after neutralization and pasteurization. Samples were also taken of the butter made from each churning. Titratable acidity, fat, WIA, and butyric acid were determined in the cream samples and WIA and butyric acid were determined in the butters. Analytical data, including mold counts on these creams and butters, are given in Table 2.

Another series of cream and butter samples were taken from churns made from vats of cream as customarily handled in commercial production, without attempt to classify each individual can of cream. Each vat was graded by the manufacturer as commercial No. 1 or 2 cream. Analytical data on these churns are presented in Table 3.

In reviewing the results in Tables 2 and 3 there is no evidence that neutralization as practiced by the industry in butter making causes an increase in either WIA or butyric acid in cream. With the exception of 4 samples in Table 2 there was no indication of an increase in WIA of the butter over that of the respective neutralized cream. In these four churns, namely, Nos. 8, 14, 33, and 36 the differences of 49, 30, 35, and

TABLE 2.-Authentic butter-1950

SAMPLE NO.	VAT ACIDITY AS LACTIC		CLASSES OF CREAM IN CHURN						CREAM				BUTTER		NEUTRALIZED USED (SEE TABLE I FOR TYPE)	MOLD
	BEFORE NEUTRALIZATION	AFTER NEUTRALIZATION	0	1	2	3	BEFORE NEUT. AND PASTEUR.	AFTER NEUT. AND PASTEUR.	WIA ON FAT BASIS	BTYRIC ON FAT BASIS	WIA ON FAT BASIS	BTYRIC ON FAT BASIS	WIA ON FAT BASIS	BTYRIC ON FAT BASIS		
1	0.45	per cent	per cent	per cent	per cent	per cent	mg./100g	mg./100g	mg./100g	mg./100g	mg./100g	mg./100g	mg./100g	mg./100g	1	per cent
2	0.17	0.23	60	40			258	243	1.7	1.7	144	0.4	14	4	2	
3	0.40	0.09	53	47			139	164	0.0	0.0	125	0.0	0	4	0	
4	0.44	0.13	50	50			128	123	0.0	0.0	177	0.0	4	4	20	
5	0.24	0.07	40	60			245	209	4.7	3.3	146	0.0	4	4	22	
6	0.44	0.10	100	100			143	175	0.0	0.0	197	0.0	4	4	22	
7	0.43	0.11	100	100			261	184	3.5	2.8	205	0.0	4	4	8	
8	0.60	0.12	41	59	4		259	198	0.0	0.0	209	0.0	4	4	10	
9	0.84	0.24	21	75	4		213	160	1.9	2.4	248	0.8	3	1	14	
10	0.72	0.29	14	81	5		380	304	3.0	4.0	307	1.0	2	1	8	
11	0.68	0.35	16	78	6		382	326	3.0	3.0	283	0.0	2	1	18	
12	0.57	0.22	17	75	8		286	298	4.0	4.0	256	0.0	1	1	46	
13	0.60	0.24		91	9		307	275	3.0	4.0	239	0.9	4	4	28	
14	0.65	0.09	4	87	9		296	218	4.2	4.2	248	0.4	4	4	42	
15	0.57	0.24	5	84	11		390	218	4.0	3.0	190	0.4	4	4	52	
16	0.73	0.25	14	74	12		277	269	3.0	3.0	255	0.8	3	3	14	
17	0.76	0.30	6	82	12		345	256	4.0	4.0	254	0.8	4	4	66	
18	0.59	0.30	13	75	12		482	360	5.0	3.0	316	0.9	2	2	52	
19	0.83	0.25	13	74	13		317	311	6.0	7.0	272	0.7	4	4	48	
20	0.50	0.23	8	86	13	1	303	300	3.6	4.0	255	0.0	6	6	34	
21	0.66	0.24	8	58	33	1	334	348	4.8	5.0	228	0.7	6	6	12	
22	0.59	0.19	13	50	36	1	365	384	4.3	6.6	325	0.6	6	6	20	
23	0.72	0.28	11	43	36	3	427	430	6.2	5.0	353	0.0	6	6	32	
24	0.66	0.26	61	61	36	3	418	422	4.8	5.1	361	0.7	6	6	66	
25	0.63	0.18	7	45	37	11	380	375	7.8	7.4	358	0.0	6	6	14	
26	0.68	0.27	59	41	44	5	456	466	9.0	7.0	380	1.5	8	8	58	
27	0.65	0.19	51	44	44	6	278	306	4.8	5.2	279	0.0	5	5	8	
28	0.74	0.22	39	39	47	14	384	407	6.0	5.9	315	0.0	5	5	10	
29	0.86	0.31	45	49	6	6	277	270	6.0	3.0	251	1.1	4	4	100	
30	0.62	0.25	42	50	8	8	360	377	2.9	3.3	318	0.0	6	6	28	
31	0.97	0.21	29	29	52	19	486	476	12.0	13.0	336	1.1	4	4	98	
32	0.73	0.25	8	54	5	9	390	392	5.1	9.7	288	0.0	6	6	56	
33	0.88	0.15	25	57	42	18	372	276	8.9	5.2	311	0.8	4	4	66	
34	0.74	0.26	10	58	23	23	577	565	23.8	14.5	552	4.6	6	6	90	
35	0.88	0.22	7	10	67	81	575	560	16.3	16.7	418	2.2	6	6	74	
36	0.85	0.12	7	7	81	12	318	252	5.8	6.0	292	0.6	4	4	72	

TABLE 3.-Commercial butter-1950

SAMPLE NO.	VAT ACIDITY AS LACTIC		COMMERCIAL CLASSIFICATION OF CREAM IN VAT	CREAM				BUTTER		NEUTRALIZER USED (SEE TABLE 1 FOR TYPE)	MOLD
	BEFORE NEUTRALIZATION	AFTER NEUTRALIZATION		BEFORE NEUT. AND PASTEUR.		AFTER NUT. AND PASTEUR.		WIA ON FAT BASIS	BUTYRIC FAT BABIB		
				WIA ON FAT BASIS	BUTYRIC FAT BASIS	WIA ON FAT BASIS	BUTYRIC FAT BASIS				
1	per cent 0.44	per cent 0.13	1	mg/100 g 176	mg/100 g 3.5	mg/100 g 139	mg/100 g 4.9	mg/100 g 140	mg/100 g 0.0	4	per cent 2
2	0.51	0.24	1	260	4.3	287	4.3	256	0.0	6	30
3	0.64	0.24	1	270	3.0	280	3.0	217	0.6	3	18
4	0.53	0.20	1	273	4.3	281	4.2	248	0.0	6	18
5	0.61	0.22	1	309	4.3	289	4.5	239	0.0	3	0
6	0.85	0.23	1	316	4.0	295	5.0	299	0.8	3	50
7	0.63	0.23	1	326	5.1	325	5.1	280	1.0	3	14
8	0.69	0.23	1	333	5.1	354	5.1	274	0.0	3	28
9	0.68	0.23	1	335	6.1	335	5.0	282	0.4	1	12
10	0.67	0.24	1	350	5.1	328	5.0	303	0.8	3	40
11	0.64	0.37	1	358	5.1	322	4.2	241	0.7	3	54
12	0.74	0.22	1	374	5.6	358	5.1	330	1.1	1	4
13	0.64	0.10	1	379	3.1	292	7.5	301	0.0	4	26
14	0.90	0.28	2	363	6.1	358		344	0.8	1	20
15	0.84	0.21	2	411	11.1	394	11.5	370	1.0	3	34
16	0.78	0.19	2	539	9.4	513	8.0	478	1.1	4	80
17	0.88	0.49	Mine Run	425	5.2	404	4.1	370	1.4	2	64

TABLE 4. -Effect of roller-neutralization of cream on WIA and butyric acid

SAMPLE NO.	ACIDITY PER CENT AS LACTIC	CREAM						BUTTER		NEUTRALIZER USED (SEE TABLE 1 FOR TYPE) - mg
		BEFORE NEUT. AND PASTEUR.			AFTER NEUT. AND PASTEUR.			WIAON FAT BASIS	BUTYRIC FAT BASIS	
		WIAON FAT BASIS	BUTYRIC FAT BASIS	mg/100 g	WIAON FAT BASIS	BUTYRIC FAT BASIS	mg/100 g			
1	0.76	293	2.6	282	2.6	165	0.6	-		
2	0.67	367	5.0	364	4.5	211	0.3	1		
3	1.00	482	6.2	377	5.0	337	1.5	3*		
4	1.16	384	2.7	246	2.7	198	0.4	3*		
5	0.66	300	5.1	287	4.9	182	0.5	1		

* Not followed with lime.

40 mg per 100 g of fat, respectively, are within experimental error. Further evidence that there is no increase caused by neutralization in each of these instances is that the butter is below that of the cream before neutralization. It is particularly significant that no effect on the amount of WIA was detectable even when the strong alkali neutralizers, sodium hydroxide and carbonates, were used at the higher temperatures of 110-120 F.

To study the effect of over-neutralization of cream on WIA and butyric acid, about 5 gallons of vat cream were collected at a creamery and taken to the laboratory where it was definitely over-neutralized, pasteurized, and churned in an electrically driven churn of 12 gallon capacity. With two creams the commercial neutralizers Nos. 1 and 3, as described in Table 1, were used. With another cream a magnesium oxide-magnesium carbonate type of neutralizer was used. Results on the original creams and samples taken after neutralization and pasteurization, and the butters prepared from the creams, are given in Table 4. There was no increase in WIA or butyric acid in the butter, as compared with the cream, in any of these churns, in spite of the fact that excess alkali was in contact with the cream at all times, even during the entire pasteurization period of 30 minutes at a temperature of 155°F.

SUMMARY

Data are presented on the determination of WIA and butyric acid in 36 authentic churns of butter, classified as to quality and condition for each individual can of cream in the churn, as well as for 17 churns of butter in which the cream was commercially classified on a vat basis. The possibility of the effect of over-neutralization was studied on 5 churns of butter prepared on a pilot scale. Neutralization does not cause increase in WIA or butyric acid in creams or in the butter churned therefrom.

ACKNOWLEDGMENT

Grateful appreciation is extended to M. MacLean of the Division of Food, A. F. Ratay of the Cincinnati District and M. A. McEniry of the St. Louis District, all of the Food and Drug Administration, for their assistance in the analysis of the samples; also to F. R. Smith of the Division of Microbiology, who made the mold counts. Thanks are also due to H. A. Lepper and W. I. Patterson for their suggestions and assistance during the development of this study.

A MICRO METHOD FOR THE DETERMINATION OF
VANILLIN AND ETHYL VANILLIN IN VANILLA
EXTRACTS

By R. M. WAY and W. R. GAILEY (Crescent Manufacturing Co.,
Seattle, Washington)

The increasingly extensive use of vanilla extracts reinforced with vanillin prompted Sale (1) to suggest rules for proper labeling of such extracts. More recently, so-called ethyl vanillin (3-ethoxy-4-hydroxy benzaldehyde) has come into prominence as a reinforcing agent because its flavor strength is some three times that of vanillin, according to Federal Specification EE-E-911a. Thus, to test the validity of a labeling with respect to Sale's rules, the analyst is confronted with the problem of how to determine quantitatively the amounts of both vanillin and ethyl vanillin present in a given extract.

The usual A.O.A.C. colorimetric method for vanillin determination (2) includes both vanillin and ethyl vanillin as vanillin, since each of these phenolic compounds reacts with the Folin and Denis reagent (3). However, Lynch (4) has shown that some vanillin is lost by co-precipitation or sorption on the "lead resins" removed in this procedure. He has proposed a modification of the A.O.A.C. method and the present authors (5) have confirmed that this modification may yield correct analyses for vanillin in standard strength extracts. But they have also found that low vanillin recoveries are obtained from extracts to which one or more ounces of vanillin per gallon have been added, and that this error does not seem to be directly proportional to the concentration of vanillin.

The detection of ethyl vanillin in the presence of vanillin has been studied by Stadler (6) and a modification of his procedure has been published by Chenoweth (7). Another detection method has been suggested by Nechamkin (8) but all of these provide only qualitative results.

Since it seemed doubtful that any of these methods could be developed to permit reliable determination of both vanillin and ethyl vanillin in vanilla extracts, the authors have now extended Gailey's chromatographic procedure (9) for separation of vanillin and ethyl vanillin so that quantitative determination of these two substances may readily be accomplished and on a micro scale.

EXPERIMENTAL

Paper chromatography was conducted with Whatman No. 1 Filter paper cut into strips 2.5 cm. by 38 cm., using special care at all times to avoid contamination of this paper. For analysis of one extract, four paper strips were placed side by side with ends aligned on a *clean* glass surface. A light pencil line, the "reference line," was drawn across all strips about 2 cm from one end. Then a precisely measured volume (0.0025 to 0.0075 ml) of the extract containing the vanillin and/or ethyl vanillin (about 10

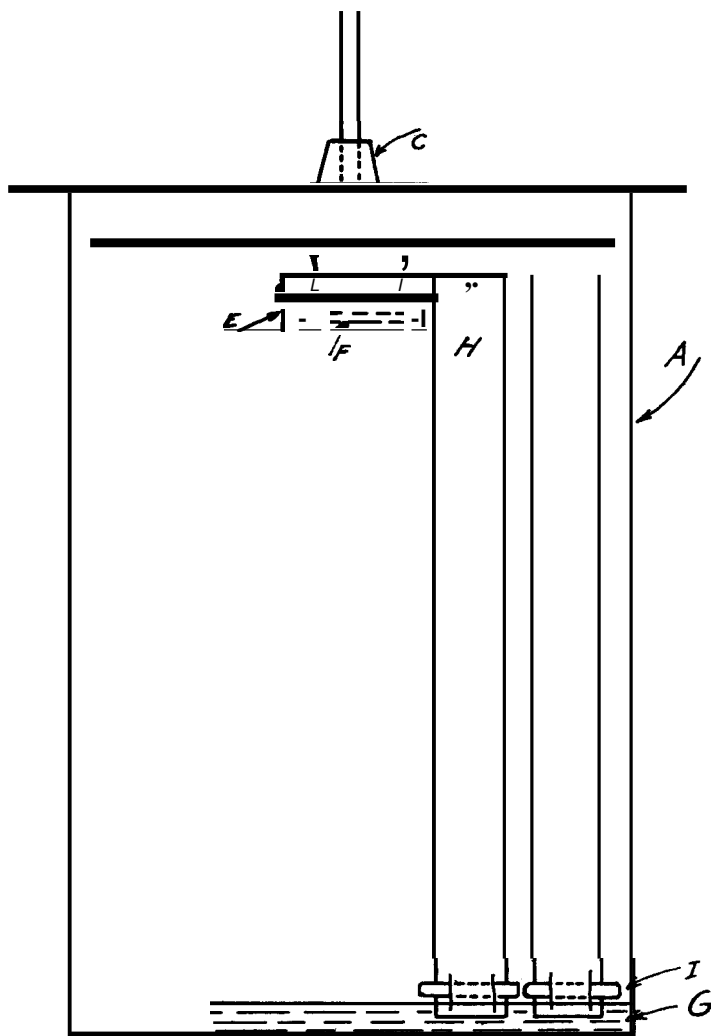

to 30 micrograms) was delivered on each strip (except on one "blank" strip) at the reference line using an ultramicroburet of the Brandt-Rehberg type described by Kirk (10). The strips were allowed to air dry at room temperature. When propylene glycol, for example, was present in the extract it was found that at least four hours air drying was necessary to avoid smearing or streaking of the chromatogram. The apparatus used

(see Fig. 1) was built around an 8"X18" glass battery jar, A, the top of which was ground flat. The jar was covered with a plate glass sheet ($\frac{1}{4} \times 9" \times 9"$) B, with a center hole in which was cemented the rubber stopper C. Through a hole in this stopper passed a glass rod assembly, D, which provided four arms in a horizontal plane inside the jar. From these arms was suspended a small glass dish, E, containing an aqueous butanol-saturated ammonium hydroxide solution (2% NH_a by weight), F. The jar was filled to a depth of about one-half inch with butanol saturated with aqueous ammonium hydroxide solution (2% NH_a by weight), G. (These solutions are prepared by diluting 19.6 ml of concentrated ammonium hydroxide, Sp. Gr. 0.992, to 250 ml, shaking a portion with butanol in a separatory funnel and allowing to stand until the phases separate.)

The air dry paper strips including the "blank" were suspended from the rods, D, by use of wire clips, H, utilizing short glass rods, I, to weight the bottom of the strips. This assembly was placed in jar, A, so that the strips did not touch solution, G. After the strips had been equilibrated in the closed jar for at least one-half hour, the device D was lowered by sliding the vertical glass rod through rubber stopper, C, until the strip ends were submerged about one-half inch into solution, G. At least 18 hours at $23 \pm 1^\circ\text{C}$. was allowed for development of the chromatogram. The four strips per sample were then removed from the chamber and allowed to air dry.

To locate vanillin and ethyl vanillin positions, one strip was sprayed or painted with a saturated solution of 2,4-dinitrophenylhydrazine in 2 N HCl, and characteristic orange spots appeared where the carbonyl containing phenolic compounds were situated. This "indicator" strip was air dried and the dried "indicator" strip was placed on a *clean* glass sheet along side of the other strips so that the reference lines coincided. The areas indicated to be occupied by vanillin and ethyl vanillin were marked and cut off. The cut-off sections of the strips, and also corresponding segments of the "blank," were placed in separate appropriate known volumes of *pH* 10.7 aqueous buffer solution (15 ml 0.1 M NaOH+50 ml 0.15 M Na_2HPO_4). For example, about 10 ml of buffer solution was found suitable for each approximately 20 micrograms of phenolic substances originally placed on the paper strip. About one-half hour was allowed for solution.

The clear solutions so obtained were then decanted directly into quartz absorption cells (one cm light path) and optical densities of the several solutions were determined, using a Beckman Model DU Spectrophotometer at wave lengths of 3475 Å and 3460 Å for vanillin and ethyl vanillin, respectively. This instrument was standardized against the clear solutions from the "blank" strips which were thus taken to have zero optical density. Concentrations of the phenols in the eluant solutions were calculated using the relations:

$$\text{O. D.} = kcl = \log \frac{I_0}{I}$$

where O. D. = Optical density; k = extinction coefficient; c = concentration of vanillin or ethyl vanillin in milligrams per liter; l = light path = 1 cm; and I_0 and I = intensity of incident and final light. From work with the pure substances, it was established that Beer's law is obeyed up to phenol concentrations of about 10 milligrams per liter of buffer solution, and that extinction coefficients were $k_{3476} A=0.1676$ and $k_{3460} A=0.1489$, for vanillin and ethyl vanillin, respectively. Computation of phenolic concentration, c , using the above equation, thus involved insertion of the proper extinction coefficient and of the observed optical density with $l=1$ cm.

DISCUSSION

The reproducibility of results obtained by the authors' "micro" method is indicated in Table 1 by the agreement found among quadrupli-

TABLE I. - True vanilla extracts^a

SAMPLE	VANILLIN		ETHYL VANILLIN	
	ADDED	FOUND ^b	ADDED	FOUND ^b
	(g/100 ml)	(g/100 ml)	(g/100 ml)	(g/100 ml)
I	0.0	0.18	0.0	- ^c
I	0.0	0.18	0.0	-
I	0.0	0.18	0.0	-
I	0.0	0.18	0.0	-
I-V	1.0	1.19	0.0	-
I-V	1.0	1.13	0.0	-
I-VE	1.0	1.17	1.0	1.05
I-VE	1.0	1.20	1.0	1.01
I-VE	1.0	1.23	1.0	1.07
II	0.0	0.38 (0.29)d	0.0	-
II	0.0	0.30 (0.28)d	0.0	-

^a Samples furnished by Crescent Manufacturing Company.

^b Analysis conducted by present "micro" method.

^c - signifies "not determined."

^d Values in parentheses were determined by use of the official A.O.A.C. method (2).

cate analyses for vanillin in a true vanilla extract designated as I. Satisfactory absolute accuracy in analysis was secured when I was enriched with one gram of pure vanillin per 100 ml of extract to yield I-V, and also when I was enriched with one gram each of pure vanillin and pure ethyl vanillin to provide sample I-VE. The A.O.A.C. colorimetric method (2) gave somewhat lower values for vanillin than those determined by the "micro" method on a different true vanilla extract called II.

Two commercial true vanilla extracts, III and IV, were tested to ascertain whether substances were present in representative commercial formulations which would interfere with the micro-method. It was found (Table 2) that satisfactory chromatographic separation of the two phenolic compounds was effected and that consistent quantitative results were obtained. However, results by the official method were lower, especially with sample IV. It may be noted that the labels on III and IV declared added vanillin but made no mention of ethyl vanillin, although additional chromatographic work indicated that a substantial amount of this substance was present in commercial true vanilla extract IV.

TABLE 2.-Commercial true vanilla extracts^a

SAMPLE	VANILLIN FOUND		ETHYL VANILLIN FOUND
	By A.O.A.C. METHOD	BY MICRO METHOD	BY MICRO METHOD
	(g/100 ml)	CD(100 ml)	(g/100 ml)
III	1.53	2.28	0.0
III	1.57	2.28	0.0
IV	1.00	1.58	0.58
IV	1.00	1.42	0.47

^a Samples obtained from an ice cream manufacturer.

With a certain imitation vanilla extract obtained from an ice cream manufacturer, analysis in triplicate by the micro method indicated the presence of 0.0, 0.0, and 0.0 grams of ethyl vanillin, and of 0.92, 0.88, and 0.91 gram of vanillin per 100 ml of extract, while the official method gave lower results; *i.e.*, 0.59, 0.60, and 0.56 g/100 ml.

Analysis of a powdered imitation vanilla extract, which was an imitation vanilla extract dried on cerelose or dextrose, was carried out by leaching one gram of the powder with 95% ethanol, then diluting to 200 ml with this solvent to provide the solution for chromatography. In triplicate determinations, there were found 20.6, 20.6, and 21.3 grams of vanillin, and 11.6, 12.2, and 12.5 grams of ethyl vanillin, per 100 grams of the powdered preparation.

Thus, in summary, a micro method based on chromatographic and spectrophotometric techniques has been described and is proposed for determination of vanillin and ethyl vanillin in vanilla extracts and similar products. Experimental evidence has been recorded to support the reliability of the method and to point out possible shortcomings in the official A.O.A.C. method for vanillin.

The authors wish to express their appreciation to the management of the Crescent Manufacturing Company for permission to publish this work, to Linda Millis for assistance in carrying out much of the experi-

mental work, and to Dr. Joseph L. McCarthy for aid in preparing the manuscript.

LITERATURE CITED

- (1) SALE, J. W., "Proc. Sixteenth Annual Convention," 1925, Flavoring Extract Mfrg. of the U. S.
- Mim. Circular "Flavoring Extracts Under the Federal Food, Drug, and Cosmetic Act," Food and Drug Administration, Washington, D. C.
- (2) *Methods of Analysis*, 6th Edition (1945).
- (3) FOLIN and CIOCALTEU, *J. Bio. Chem.*, 73, 627 (1929).
- (4) LYNCH, H. J., and DEAHL, NEVLON, *This Journal*, 23, 429 (1940).
- (5) WAY, R. M., and W. R. GAILEY, unpublished results.
- (6) STADLER, P., and WAGNER, K., *Z. Anal. Chem.*, 108, 161 (1937).
- (7) CHENOWETH, H. W., *Ind. Eng. Chem. Anal. Ed.*, 12, 98 (1940).
- (8) NECHAMKIN, H., *Ibid.*, 15, 268 (1943).
- (9) GAILEY, W. R., *Chemist Analyst*, 39, No.3, 59 (1950). (J. T. Baker Chemical Co., Phillipsburg, N. J.)
- (10) KIRK, P. L., *Quantitative Ultra-Micro Analysis*, John Wiley and Sons (1950), page 31, Fig. 13.

POPULATION STUDIES OF *MICROCOCCUS PYOGENES* VARIETY *AUREUS* 209

I. VARIATIONS INFLUENCING PHENOL COEFFICIENT TEST RESULTS*

By B. WESLEY CATLIN† and A. J. SALLE (University
of California, Los Angeles)

INTRODUCTION

The phenol coefficient test as represented by methods of the U. S. Food and Drug Administration (1) and the Association of Official Agricultural Chemists (2) is widely employed for evaluating disinfectants, despite incessant controversy as to its validity in special cases. The numerous variables that have been recognized as influencing test results relate to: (A) the character of the disinfectant; (B) the character of the test bacteria and factors influencing the culture prior to its use in the test; (c) factors influencing the disinfectant-bacteria treatment mixture; and (n) factors influencing growth of organisms subcultured from the test mixture. Widespread critical attention has been focused upon the first and the last two categories. Variations in the hydrogen ion concentration, surface tension, temperature, time of sampling, and amount of organic matter present have all been clearly shown to influence disinfectant action. Numerous techniques have been advocated for facilitating exposure of the test bacteria to the disinfectant and for removing a fair sample of exposed cells. New culture mediums have been devised to provide more adequate

* Research carried out during 1948, with the aid of a grant from Winthrop Chemical Co., Inc., administered by the University of California.

† Present address: Department of Microbiology and Immunology, Marquette University School of Medicine, Milwaukee 3, Wisconsin.

environmental conditions for bacterial growth in the subculture series and to antagonize residual traces of the test disinfectants. However, with a few notable exceptions (see references, 3, 4) relatively little attention has been paid to the second category, which involves the natural variability of the test strains.

One striking feature of results of phenol coefficient tests with quaternary ammonium compounds has been the great variation in critical killing dilutions. The difficulties encountered in testing these compounds led to a cooperative study, extending over a period of two years, by the Insecticide Division, U. S. Department of Agriculture, and certain members of the National Association of Insecticide and Disinfectant Manufacturers. In a report of this study (5), widely varying killing dilutions were given for the test quaternary disinfectants. Phenol control tests on *M. pyogenes* var. *aureus* 209 test cultures showed, in general, a substandard resistance. However, the report stated: "... no correlation was observed between the levels of activity reported for phenol and the various quaternary ammonium compounds by the individual laboratories. Thus, the wide variations ... cannot be directly attributed to differences in the resistance of the test cultures employed." A recent report (6), perhaps recognizing that such a conclusion is dubious, recommends a greater stringency in regard to designation of official test strains. However, even this may not be enough to assure standard culture behavior.

The fallacy of using the phenol coefficient test in the evaluation of non-phenolic type disinfectants has frequently been indicated. However, the correlate is less commonly acknowledged: that uniformity of resistance to phenol of test cultures is no assurance of uniformity of resistance to other types of disinfectants. Testing with disinfectants characterized by different mechanisms of action may reveal genetically conditioned differences in resistance between cells that appear to be homogeneous on the basis of ordinary criteria, such as morphology, cultural reactions, and standard phenol resistance.

It is by now well established that bacteria are subject to heritable variations (see 7, 8, 9, 10). That is to say, as a result of spontaneous genetic change (mutation) occurring during cell division, one cell may differ from the other cells in the growing culture. Whether this variant cell will divide and its variant type eventually constitute a significant proportion of the grown culture will depend on its adaptive significance in competition with the parent type in the particular culture-environment. Gross changes of the environment, such as use of a different culture medium, incorporation of some toxic agent, change in *pH* or temperature will obviously tend to alter the selective advantage possessed by the parent type and may allow the establishment of one or more variant types. Also of importance are the less obvious environmental differences introduced by media of different batches or ages, peptones derived from different protein sources, dif-

ferent degrees of aeration during growth of the culture, and variations in technique among different laboratories as to method of preparation, storage, and frequency of transfer of stock cultures.

Among the genetic variations that have been studied in *M. pyogenes* var. *aureus* are increased degrees of resistance to various antibacterial agents. Cells of "pure cultures" have been found to develop penicillin resistance at a rate of about 1×10^{-8} (9) and to develop sulfonamide resistance at a rate of about 2×10^{-9} to 4×10^{-10} (8). It has been demonstrated in both instances that certain degrees of resistance can develop spontaneously in cells in the absence of penicillin or sulfonamide and that such resistant bacteria may be found in any large population. Resistance in these particular cases is clearcut and stable during subculture in regular media, thus satisfying the criterion of genetic change: heritability of variant character in the absence of the specific selecting agent. This criterion may be difficult to satisfy, however, in some instances. For example, a mutation that is of great survival value against the action of a bactericide may, nevertheless, render the variant cell deficient in growth ability or in another way inferior to other cell types which may therefore outgrow or displace it during the first subculture. Population phenomena of this sort have tended to obscure the genetic basis of resistance to disinfectants.

Accordingly, intrapopulation differences of resistance may be difficult to demonstrate. Advantage may be taken, however, of the occurrence in some strains of *correlated* variations; as, for example, where a certain sort of resistance is associated with variation in colony pigmentation. In such a case, there may be a single physiological or genetic mechanism underlying the changes exhibited in the bacterial characters. On the other hand, variant character frequently appears unaccompanied by any other obvious change. Thus, it is not surprising to find a "typical" morphological and biochemical pattern in bacteria that have become resistant to some antibacterial agent.

The practice of "purifying" a bacterial culture by isolation of typical single colonies involves the inherent risk that the isolate may be atypical in some initially unapparent way. The probability of such an occurrence is slight, but when cultures of an identical strain are maintained for years in different culture collections, there is an increasing likelihood that genetic differences may accumulate.

This study sought evidence bearing on the following three questions:

- (1) Are cultures of *M. pyogenes* var. *aureus* 209, obtained from different reputable culture collections sufficiently similar to justify the confidence that they will give duplicate phenol coefficient results?
- (2) Do substrains isolated from each show significant independent variation in resistance to two different disinfectants?
- (3) In repeated phenol coefficient tests of a quaternary ammonium

compound, do all strains exhibit fluctuation in critical killing dilutions or is it possible with some strain to obtain uniform results?

EXPERIMENTAL

Test Organisms.-Two strains of *Micrococcus pyogenes* var. *aureus* (*Staphylococcus aureus*) were employed. Both are representatives of the disinfectant-testing strain known as 209. The first, bearing the culture number 6538, was obtained in 1947 from the American Type Culture Collection. The second, which will be referred to as 209, was obtained in November, 1947, through the kindness of Dr. L. S. Stuart, Insecticide Division, U. S. Department of Agriculture.

Three successive single-colony isolations were made of each strain. Three different typical discrete colonies from the last plate were streaked to F.D.A. agar slants and constituted the parent substrains. Stock slants, protected from dehydration, were stored at room temperature after initial incubation at 37°C. for 24 hours. They were transferred only occasionally, in order to avoid unnecessary population changes which may result from frequent subcultures.

F.D.A. broth cultures inoculated from the parent substrains were incubated for 24 hours at 37°C. Daily serial transfers of one loopful of culture into fresh broth were cultivated under identical conditions. Twenty-four-hour cultures of such transfers were tested for bactericide resistance.

Test Bactericides.-Phenol and benzalkonium chloride, a quaternary ammonium compound, were used. Test dilutions of phenol were made from a 5% stock solution of U.S.P. crystals. Test dilutions of benzalkonium chloride (Zephiran) were prepared from a 1:1000 solution of the commercial aqueous preparation.

Media and Methods.-In order to assure uniformity, ingredients used in the mediums were obtained in adequate quantities of the same batch number at the beginning of the work.

The F.D.A. broth used for daily subcultures of the test strains was composed of 10.0 g Difco peptone, 5.0 g Difco beef extract, and 5.0 g sodium chloride per 1000 ml distilled water. Final *pH* was 6.8 to 7.0 with no adjustment required. Broth was tubed in 15-ml quantities in cotton-plugged 22 X 150 mm Pyrex tubes, and sterilized by autoclaving at 15 lbs pressure for 30 minutes.

The medium used for subculturing from the phenol test dilutions was F.D.A. broth prepared as above with the addition of 0.07% Difco agar, producing a consistency similar to the "Lethen broth." Inoculation of this medium with a loopful of treated cells of which only one or two were viable resulted in isolated puffball masses of growth suspended in the agar. This facilitated reading of results and detection of "skips."

The medium used for subculturing from the benzalkonium chloride test dilutions was the modification of "Lethen broth" (11) proposed for

the NAIDM-USDA experiment No.6 test procedure for quaternary ammonium germicides (5). This medium had the following composition per liter: 5.0 g Difco beef extract, 10.0 g Difco peptone, 5.0 g sodium chloride, 1.0 g sodium thioglycollate, 0.7 g Difco agar, 0.7 g lecithin (Asolectin of Associated Concentrates, Inc.), and 5.0 g Tween 80 (Atlas Powder Co.). The first five and last two ingredients, in separate containers of distilled water, were dissolved by heating in an Arnold. They were mixed and reheated for 15 minutes, after which Resazurin Certified (1 mg contained in 1 ml) was added and the *pH* was adjusted to 7.0 with 10% sodium hydroxide. The medium, made up to a final volume of 1000 ml, was tubed in 15 ml quantities and autoclaved at 15 pounds pressure for 20 minutes.

F.D.A. agar supplemented with 0.5% Difco yeast extract was used to ascertain colony pigmentation. Plates were streaked with a loopful of broth culture in such a way as to give about one hundred isolated colonies. After 24 hours incubation at 37°C. followed by 1-2 days at room temperature, counts were made of the different kinds of pigmented colonies, and percentages were computed. The proportion of white colonies to yellow in a culture was recorded as the percentage (to the nearest 5%) of white colonies in the total number of colonies counted.

A technique essentially similar to the A.O.A.C. method (2) was used to determine culture resistance, that is, to find the highest dilutions of phenol and of benzalkonium chloride capable of inhibiting subsequent growth of the test culture. Two modifications were used, however, in order to increase the precision and duplicability of results: (1) the daily transfers of test cultures were made at appropriate times so that each could be tested at exactly 24 hours. Immediately before use, the culture was rapidly and repeatedly expelled from a sterile pipette to reduce clumps of cells. After a preliminary turbidity check, this suspension was diluted with sterile F.D.A. broth until it gave a reading of 40 in a photoelectric colorimeter, which was adjusted each time to give a reading of 50 with a No.7 McFarland barium sulfate standard (prepared by mixing 7 ml of 1% barium chloride with 93 ml of 1% sulfuric acid). The number of viable cells present in such a standardized culture averaged 4.2×10^8 . (2) the second modification of the phenol coefficient procedure involved the use of a special large-capacity water bath, which allowed continual, vigorous shaking of the treatment tubes. The immersed test-tube rack was motor-driven at a uniform rate of 180 oscillations per minute, and the temperature of the water was thermostatically maintained at 37°C. When duplicate phenol coefficient tests were run with and without shaking during the 10-minute exposure period, higher critical killing dilutions for both phenol and benzalkonium chloride with fewer "skips" and "wild plusses" were obtained in the series subjected to shaking. This is confirmed by Quisno *et al.* (12), who found that with routine methods of exposure involv-

ing no special shaking a few bacterial cells tend to survive at the junction of the meniscus and the wall of the medication tube. Similar considerations have led to the recent proposal (6) that agitation of medicant tubes be made mandatory at specified times during the test.

In other respects the technique conformed to the official method. Suitable dilutions of the germicides were prepared, having a volume of 5 ml. These tubes and the adjusted test culture were warmed in the 37°C. water bath. With a 1-ml pipette, 0.5 ml of the bacterial suspension was introduced into each tube of the series at appropriate time intervals. Care was taken to avoid dripping culture on the sides of the tube above the level of the germicide. Inoculated tubes were inserted directly into the moving water-bath rack, so that they were continually shaken. Samples were removed with a loop (internal diameter, 4.0 mm) from each tube at 5- and 10-minute intervals and inoculated into tubes of the appropriate subculture medium. Subcultures were incubated at 37°C. for 5 to 7 days, and checked daily for evidence of growth. This prolonged incubation period allowed the detection of slow-growing resistant cells. The highest dilution that killed the test suspension in 10 minutes, but not in 5 minutes, at 37°C. was considered to be the critical killing dilution.

Results.-Colonies of strain 6538 on nutrient agar are typically circular with an entire margin and convex elevation; smooth and glistening, with a golden-yellow pigment and a butyrous consistency. Strain 209 is culturally similar, except that its pigment is characteristically a pale cream color. In other respects, both conform to the description of *M. pyogenes* variety *aureus* given in Bergey's Manual (13) except that no H₂S is produced in deep stabs of Bacto Peptone Iron agar and fermentation of 0.5% glycerine broth is slow or negative.

During the process of daily serial transfer in F.D.A. broth with 37°C. incubation, all substrains of 6538 tested gave rise within 30 days to variants that produced opaque white colonies on F.D.A.-yeast extract agar. These white colonies were smooth, and resembled the typical parent colonies except for the absence of golden-yellow pigmentation. Isolated white colonies were picked, subcultured in F.D.A. broth, and tested to determine their resistance to the bactericides. They were found to be significantly less resistant to phenol than the golden-pigmented parent. In 72 tests with 6538-1 (substrain 1), the 10-minute phenol killing dilution was 1-130 or higher for all cultures of the white variant tested; whereas for broth cultures of the yellow parent type the range of 10-minute killing dilutions was 1-100 to 1-120 in all tests except one, which showed a killing dilution of 1-130.* Thus, in respect to resistance to the bactericidal activity of phenol, this substrain exhibited a sharply bimodal distribution,

* Dilutions of 1-100 and 1-110 represent resistance levels equivalent to the standard phenol resistance (1-80 or 1-85) specified for the A.O.A.C. tests at 37°C., since our tests were run with constant shaking of the treatment tubes, resulting in more complete exposure. The white variant was therefore substandard in its resistance.

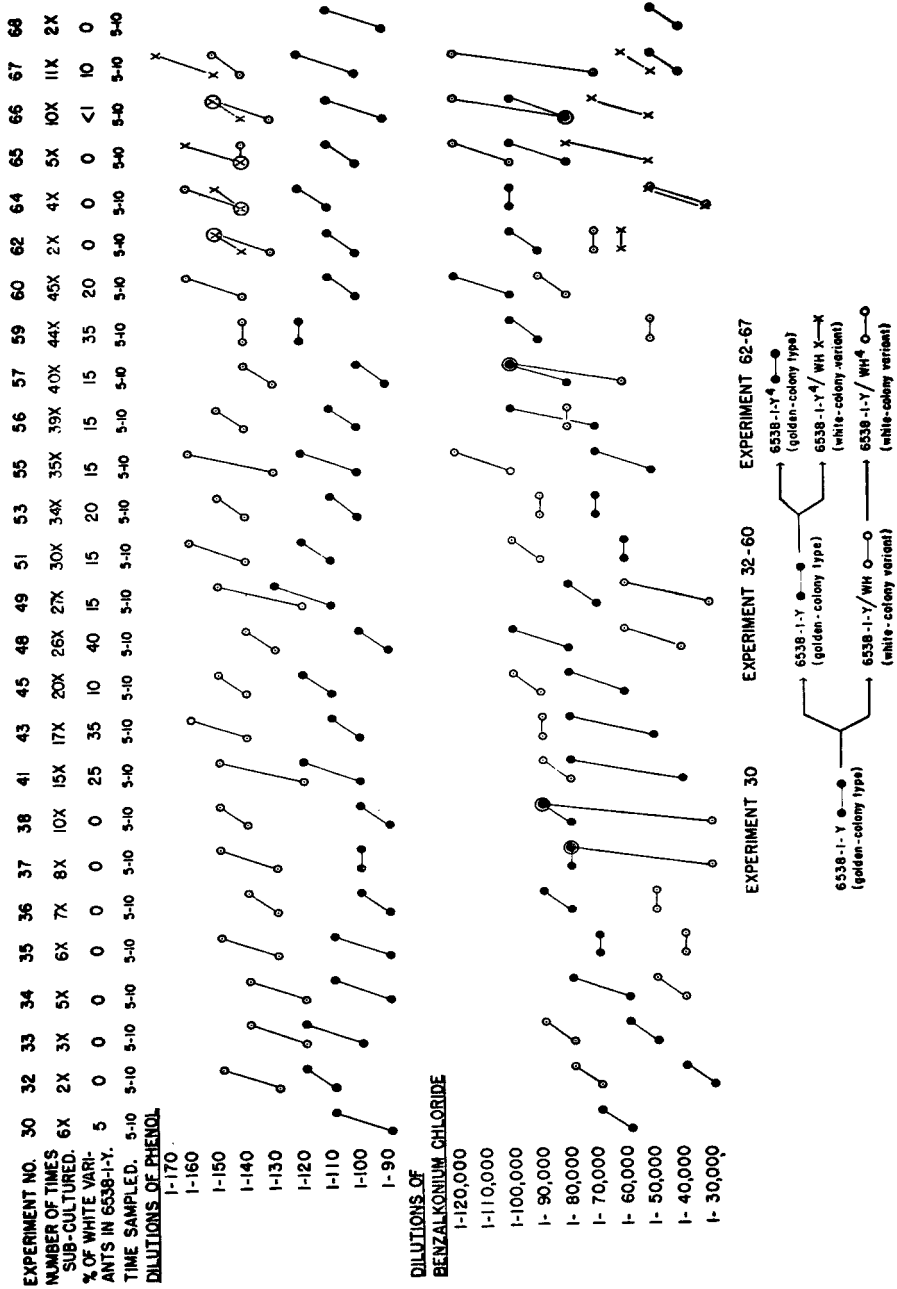

Fig. 1.—Results of phenol coefficient tests at 37°C. with *M. pyogenes* var. *aureus* 6538-1. Circles connected by lines represent 5-minute and 10-minute killing dilutions of phenol and benzalkonium chloride, in 26 experiments with cultures of the parent type (golden-pigmented colonies) and white-pigmented-colony variants.

with no overlap between the two groups. However, no such neat difference between the two types was demonstrable for resistance to benzalkonium chloride. The range of 10-minute killing dilutions of this bactericide for both strains was 1-40,000 to 1-120,000, with the majority falling between 1-50,000 and 1-100,000.

Two series of these experiments with 6538-1 will be discussed in some detail, since they are representative of the resistance responses of strain 6538. Results are shown in Figure 1. Experiment 30 tested a 24-hour F.D.A. broth culture which had been serially subcultured at 37°C. six times since the last of a series of single-colony isolations. The critical killing dilutions were 1-110 for phenol and 1-70,000 for benzalkonium chloride. F.D.A.-yeast extract agar streaked with a loopful of the test culture revealed a mixture of white and yellow colonies, although agar streaked a day earlier from the subculture that had been the source of the inoculum for this test culture showed only golden-pigmented colonies. Isolated colonies representative of the white-pigmented variant (6538-1-yjwh) and of the yellow parent type (6538-1-y) were picked from the experiment-30 plate and inoculated into F.D.A. broth tubes. After incubation at 37°C. for 24 hours, a loopful of each was subcultured in fresh broth and incubated for 24 hours. These 2X transfers (=second time transferred), after being used to inoculate fresh broth, were then tested for resistance to both disinfectants. Serial transfers of the two cultures were made daily until the 45th day, and 19 tests were made of their resistance during this period. The bimodal distribution of phenol resistance exhibited by the two types is clearly shown in Figure 1, in which the points connected by lines represent the 5-minute and 10-minute killing dilutions. As far as resistance to benzalkonium chloride is concerned, these data of Figure 1 mainly show that both types exhibit great variations of critical killing dilution in tests run under stringently standardized conditions.

The independent variation shown by cultures representing the two colony-pigmentation types suggests that population variables are involved. For example, the critical killing dilution of benzalkonium chloride in experiment 32 (Fig. 1) was 1-40,000 for 6538-1-y and 1-80,000 for 6538-1-yjwh, although the test dilutions for each were aliquots of the same series of dilutions, the conditions of exposure were the same, and both test cultures, which were of standard turbidity, had been transferred twice in tubes of the same batch of broth and maintained under identical conditions. In this series, further transfers of 6538-1-y exhibited increasing sensitivity to benzalkonium chloride, so that the 7X transfer was killed by 1-90,000; this was followed by leveling off of sensitivity and increasing variation.

This type of resistance pattern is not necessarily characteristic of all 6538-1-y populations established by picking different yellow colonies, as is shown in the last part of Figure 1. New colony isolations were made

from experiment-60 plates streaked from the 45X F.D.A. broth transfer. An isolated white colony (*6538-1-y/wh*⁴) was picked from the white series. From the *6538-1-y* plate, which showed 20% white colonies, a yellow colony (*6538-1-y*⁴) and a white colony (*6538-1-y⁴/wh*) were picked. Each of the three colonies was inoculated into separate tubes of F.D.A. broth and tested as before. The general picture of variation prevailed, but the initial resistance of the 2X transfer of the yellow-colony type was lower (higher killing dilution) than before. The last column in Figure 1 gives the results on a 2X F.D.A. broth culture, which had been inoculated from a yellow colony obtained independently from a series of three single-colony isolations from the 6538-1 parent slant. Here, the resistance to benzalkonium chloride was again higher, the critical killing dilution being 1-50,000.

F.D.A.-yeast extract agar streaks of the cultures showed that *6538-1-y/wh* remained homogeneous with respect to colony pigmentation throughout the entire series of transfers. This was true of all cultures tested of the white-type variant of strain 6538, although reversions could be obtained under special conditions. The parent type, *6538-1-y*, on the other hand, produced variants, sometime between the 6X and 15X transfers in different series, so that the populations throughout the subsequent transfers consisted of two types, producing yellow and white colonies.

In contrast to strain 6538, serially transferred F.D.A. broth cultures of strain 209 exhibited considerable stability of colony type. In several series colony pigmentation remained homogeneous throughout 30 days of subculturing. However, in two series of daily subcultures colony variants were detected. The colonies characteristic of the parent type are a pale cream color, frequently verging on white. In one case, an isolated yellow-pigmented variant colony appeared on the plate streaked from the 4X transfer. When picked and grown in broth, it produced a granular type of growth unsuitable for use as a test culture. In the other case, agar streaked from a 19X transfer revealed a number of medium-yellow colonies typical of the stock in other characteristics. Cultures of this yellow variant subsequently produced reversions back to a white-pigmented colony type.

Thirty-eight tests of resistance to the two disinfectants were performed on cultures of these two colony types, the whitish parent (*209-1-wh*) and the yellow variant (*209-1-wh/y*). Results, which were obtained in the same manner as in 6538 tests, are tabulated in Table 1. The more detailed presentation of data relating to number of culture transfers has been omitted here, because it would serve only to show the same sort of variation previously indicated. Unlike the 6538 behavior, the resistance of both 209 types to phenol was essentially the same in distribution, the range of critical killing dilutions being 1-110 to 1-150 for the parent and 1-110 to 1-140 for the variant. Their resistance to benzalkonium chloride,

TABLE 1.—*Ranges of critical killing dilutions of phenol and benzalkonium chloride against two substrains of M. pyogenes var. aureus 209, at 37°C.*

(Results of 38 tests, each culture tested simultaneously against both disinfectants)

DILUTIONS	NUMBER OF TESTS SHOWING EACH CRITICAL KILLING DILUTION	
	SUBSTRAIN 209-1-wh (PARENT TYPE)	SUBSTRAIN 209-1-wh/y (YELLOW VARIANT)
Phenol:		
1-150	2	0
1-140	3	3
1-130	8	6
1-120	5	5
1-110	3	3
Benzalkonium chloride:		
1-110,000	4	0
1-100,000	5	3
1- 90,000	7	4
1- 80,000	1	4
1- 70,000	2	3
1- 60,000	1	0
1- 50,000	1	0
1- 40,000	0	2
1- 30,000	0	1

however, was found to differ, the white parent form being somewhat more sensitive. Its range of resistance in terms of critical killing dilutions was 1-50,000 to 1-110,000, only 5 of 21 tests showing results below 1-90,000; whereas the range for the yellow-colony variant was 1-30,000 to 1-100,000, and 10 of the 17 tests gave results below 1-90,000.

In order to obtain critical data bearing on the third question, it was necessary to derive a strain that was known to be homogeneous in respect to benzalkonium chloride resistance. In brief, this was accomplished by cultivating cells identical with those used in the phenol coefficient experiments in broth containing benzalkonium chloride. Cells that were initially able to grow in the presence of a dilution of 1-550,000, but were completely inhibited in 1-500,000, were serially subcultured in increasing concentrations until they were finally able to multiply in dilutions of 1-100,000 or even 1-85,000, a fivefold increase in tolerance. Inocula from such cultures were streaked on F.D.A.-yeast extract agar. Isolated colonies were picked and subcultured in plain F.D.A. broth under the standard conditions. These rigorously selected populations were found to retain their increased tolerance to the bacteriostatic action of benzalkonium chloride even after 200 serial subcultures in the absence of this compound. F.D.A. subcultures of a number of colony isolates were tested by the regular phenol coefficient method for resistance to phenol and benzalkonium chloride. Twenty-four-hour cultures were generally considerably less turbid than

similar cultures of the parent strain, even when larger inocula were employed, probably owing to slower growth rates. Accordingly the test cultures were centrifuged, immediately before use, in order to concentrate the bacterial suspension to the standard turbidity.

Results of 16 phenol coefficient tests on populations of the substrain 6538-1 possessing increased benzalkonium tolerance are presented in Figure 2. The letters at the top of the figure designate cultures started from colony isolations made from different tolerance experiments. The number below the letter indicates, as before, the number of times the cultures had been transferred in F.D.A. broth prior to testing. Comparison of Figures 1 and 2 discloses two differences in behavior. The range of

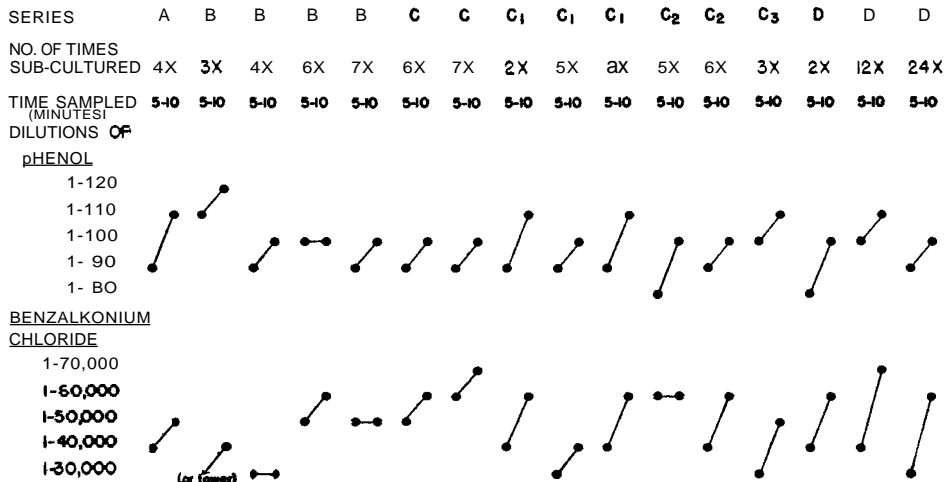

FIG. 2.-Results of phenol coefficient tests at 37°C. with *M. pyogenes* var. *aureus* 6538-1-y/rz cultures tolerant to benzalkonium chloride.

Circles connected by lines represent 5-minute and 10-minute killing dilutions of phenol and benzalkonium chloride.

critical killing dilutions of benzalkonium chloride for the tolerant cultures (6538-1-y/rz) was 1-30,000 to 1-70,000. This represents both a narrower dilution range—that is, a marked reduction in variation—and a somewhat greater average resistance than were shown by the parent substrain (6538-1-y) under identical culture and test conditions. The range of critical killing dilutions of phenol was 1-100 to 1-120. Like the parent type, the tolerant cultures produced golden-yellow colonies.

DISCUSSION AND CONCLUSIONS

The data in Figure 2 clearly show that with a group of homogeneous test populations, it is possible to obtain relatively uniform killing dilution results with benzalkonium chloride. The fact that the homogeneity of

these cultures was obtained by isolating variant cells possessing benzalkonium tolerance is not relevant to this analysis because the test cells themselves had been serially subcultured in the absence of this compound as many as 24 times. These substrains, then, can be regarded as "pure cultures" of strain 6538-1-y possessing relatively uniform levels of resistance to both phenol and benzalkonium chloride. In marked contrast is the high degree of fluctuation in critical killing dilution results (shown in Figure 1) obtained under identical test conditions with serially transferred standard cultures of strains 6538 and 209. This suggests that differences in resistance of the components of heterogeneous test culture-populations contribute to the considerable variation in killing dilutions obtained with quaternary ammonium compounds.

Figure 1 also shows that despite increasing population heterogeneity, as exhibited both by colony-pigmentation types and variation in resistance to benzalkonium chloride, strain 6538-1-y exhibited a relatively uniform and standard phenol resistance. Such a well-defined level of resistance to phenol has been regarded (3) as a fairly constant and fixed characteristic property of the strain when cultures are maintained and tested according to specified procedures. The apparent homogeneity of resistance behavior of a test population that is actually heterogeneous may be partly the result of a merging of death rates characteristic of cells possessing lower and higher levels of resistance. As Rahn (14) has pointed out, when cells do not possess a uniform resistance, the more sensitive bacteria are killed rapidly, causing a steep decline in the number of survivors. The remaining ones die at a lower rate, and as the less resistant individuals are gradually eliminated, the survivor curve becomes less and less steep.

This possibility is supported by data from a study by Ortenzio, Friedl, and Stuart (3) on single colony isolations of *M. pyogenes* var. *aureus* 209. When F.D.A. broth cultures representing initial resistance levels varying from 1-50 to 1-75 were serially transferred at 24-hour intervals, within a few weeks all cultures developed resistances to phenol dilutions of 1-60 or 1-65 when tested at 20°C. by the A.O.A.C. method. Thus, recently isolated populations that may have tended to be relatively homogeneous, but possessed non-standard resistance levels, gradually became standard after further subculturing that increased the chances for heterogeneity.

As has been indicated, generalizations based on the reactions of a particular strain to a particular disinfectant may not be applicable to the resistance behavior of the same strain to a different class of disinfectant or even of different substrains to the same disinfectant. This is borne out by the experimental data descriptive of the behavior of two stocks of *M. pyogenes* var. *aureus* 209. Since both were originally derived from the identical disinfectant-test strain, they bear the same official designation-209. By this token, and because of their virtual conformity to the characterization given by *Bergey's Manual*, they are considered to be equivalent. Cultures obtained from these two sources are not identical, however,

although test cultures possessing the specified degree of resistance to phenol can readily be obtained from both stocks. Under certain conditions consistent with the official method, cultures of the two substrains, when used for evaluating even the same disinfectant, may yield genuinely different phenol coefficient test results.

Two sorts of differences in reaction were revealed between substrains 209 and 6538. In the first place, they differ with regard to stability of colony-pigmentation type when repeatedly subcultured in broth; in the second place, the colony-pigmentation variants that arise are characterized by different resistance trends. Population stability is an important characteristic for a disinfectant-testing strain, since it is customary to use broth cultures that have been serially transferred for as long as 30 days. During this time a variant introduced in the inoculum, or arising as a result of mutation during growth of the test culture, may become established in such a proportion as to allow significant heterogeneity of population response. The probability that this will occur depends not only on the rate of mutation but also on factors of population pressure and selection, such as growth rates and relative duration of viability of the parent and variant cells, that may favor or retard the establishment of the variant type during growth of the culture. Random fluctuations of the kind observed in Figure 1 in regard to the proportion of white variants in cultures of the golden-colony type parent may be due to differences of sampling (loopful of inoculum containing a different proportion of types) or to fluctuations of selection pressure. Once the pigmentation variant had been introduced into the population, both types continued to be represented in all later subcultures.

The practical importance of this particular kind of population instability, exhibited especially by 6538, lies in the fact that associated with the differences in colony-pigmentation types are differences in levels of resistance to phenol or benzalkonium chloride or both. With certain stated exceptions, the yellow-colony types tested showed somewhat greater resistance than the white-colony types. Accordingly, the presence in a test culture of pigmentation differences or other indication of variation, as revealed by inspection of isolated colonies on a suitable agar medium, should suggest that the subculture series is no longer reliable. Although it is not customary to check the broth test cultures by simultaneously streaking the inoculum onto an agar plate, laboratories engaged in testing disinfectants will increase the duplicability of their results by so doing and by discarding any test cultures showing evidence of morphological or physiological heterogeneity.

SUMMARY

The experimental data presented describe resistance responses of two stocks of *M. pyogenes* var. *aureus* 209, a disinfectant-testing strain. One stock was obtained from the American Type Culture Collection, the other

from the Insecticide Division, U. S. Department of Agriculture. Both substrains exhibited characteristic cultural and biochemical reactions, except that isolated colonies of the latter did not show the typical golden pigmentation.

Broth cultures possessing the degree of phenol resistance stipulated in the official A.O.A.C. phenol coefficient procedure could be readily obtained from both substrains. However, two kinds of differences in reaction were found: (1) in stability of colony-pigmentation type with serial subculturing; and (2) in bactericide resistance trends shown by parent types and natural variants when tested against phenol and benzalkonium chloride at 37°C. by a modified A.O.A.C. method. The significance of these differences is discussed. It is suggested that these two substrains may be sufficiently dissimilar in some cases as to yield genuinely different phenol coefficient test results when used to evaluate the same bactericide.

In repeated phenol coefficient tests, populations that were characterized by increased tolerance to the bacteriostatic action of benzalkonium chloride showed considerably less fluctuation than ordinary test cultures with respect to killing by dilutions of this quaternary ammonium compound. The experimental data strongly suggest that population variability in resistance must be considered as one of the important sources of variation or fluctuation in results of phenol coefficient tests on quaternary ammonium compounds.

REFERENCES

- (1) RUEHLE, G. L. A., and BREWER, C. M., U. S. Food and Drug Administration, Methods of testing antiseptics and disinfectants. Circular No. 198. U. S. Department of Agriculture, Washington (1931).
- (2) *Official and Tentative Methods of Analysis*. Sixth Ed. (1945).
- (3) ORTENZO, L. F., FRIEDL, J. L., and STUART, L. S., *This Journal*, 32, 408 (1949).
- (4) KLIMEK, JOHN W., and UMBREIT, L. E., *Soap Sanit. Chemicals*, 24, 137 (1948).
- (5) STUART, L. S., *Ibid.*, 23, 135 (1947).
- (6) — —, *This Journal*, 33, 791 (1950).
- (7) LURIA, S. E., *Bact. Rev.*, 11, 1 (1947).
- (8) OAKBERG, EUGENE F., and LURIA, S. E., *Genetics*, 32, 249 (1947).
- (9) DEMEREC, M., *J. Bact.*, 56, 63 (1948).
- (10) GOODLOW, R. J., MIKA, L. A., and BRAUN, W., *Ibid.*, 60, 291 (1950).
- (11) QUISNO, R. A., GIBBY, I. W., and FOTER, M. J., *Am. J. Pharm.*, 118, 320 (1946).
- (12) QUISNO, R. A., FOTER, M. J., and RUBENKOENIG, H. L., *Soap Sanit. Chemicals*, 23, June (1947).
- (13) BREED, R. S., MURRAY, E. G. D., and HITCHENS, A. P., "Bergey's Manual of Determinative Bacteriology." Sixth Ed. Williams and Wilkins Co., Baltimore (1948).
- (14) RAHN, OTTO, "Injury and Death of Bacteria by Chemical Agents." Biodynamica, Normandy, Mo. (1945).

SPECTROPHOTOMETRIC QUANTITATIVE DETERMINATION OF METHANOL IN DISTILLED SPIRITS

By GEORGE F. BEYER (Alcohol Tax Unit, Bureau of Internal Revenue, Washington, D. C.)

Egriwe (1) stated that chromotropic acid was a specific reagent for detecting formaldehyde. F. Feigl, in the 1937 edition of his book on qualitative analysis by spot tests, uses this reaction for the detection of methanol. Gakenheimer and Hartung (2) employ this reaction in testing whiskey for the presence of methanol, and Bricker and Johnson (3) have developed a quantitative spectrophotometric method of determining formaldehyde in which chromotropic acid is used as a color-forming reagent and the optical density-concentration curve is made at wave length 570 $m\mu$. Boos (4) uses the reagent as a color producer in determining methanol after oxidation to formaldehyde but makes no mention of the presence of ethanol, and the strength of his reacting solutions is different from the ones suggested in this paper. He recommends that the optical density-concentration curve be made at a wave length of 580 $m\mu$.

A review of the above methods shows that chromotropic acid and formaldehyde react to produce a violet-colored solution that is specific for formaldehyde, and that there are no interfering substances in distilled spirits. Therefore, it seemed probable that a spectrophotometric method could be developed for the quantitative determination of methanol in distilled spirits which would have advantages over the one in which Schiff's reagent is used. The review further shows that no effort has been made to regulate the amount of ethanol that should be present in order to produce the maximum amount of color. This amount has been previously determined by the author to be 22.0-24.0 per cent in the sample to be oxidized. It was also observed that nearly all investigators except Boos heated the solution after the addition of sulfuric acid. This tended to destroy the violet color.

RECOMMENDED PROCEDURE

Distill and prepare sample as directed in Methods of Analysis, A.O.A.C., Ed. VII, Section 9.27.

REAGENTS

(1) *Potassium permanganate* 80ln.-Dissolve 3.0 g of $KMnO_4$ and 15.0 ml of strong H_2PO_4 in 100 ml water. Renew soln every four weeks.

(2) *Sulfuric acid*, conc.

(3) *Sodium bisulfite*.

(4) *Sodium salt of chromotropic acid (Sodium 1,8-dihydroxy-naphthalene-3,6-disulfonate)*.-10.0% soln. Filter if not clear.

DETERMINATION

Transfer 0.25 ml of diluted sample as prepared under 9.27 to test tube 20 X 150 mm and add 2.0 ml of the $KMnO_4$ soln. Cool and allow to stand ca four min., then decolorize with a little of the dry sodium bisulfite. Now add 0.6-0.7 ml of the

chromotropic acid soln. (If only one or two analyses are to be made, add 50 mg of the solid reagent to avoid necessity of preparing the 10% soln.) Add 10.0 ml of conc. H_2SO_4 slowly with continuous shaking. Mix well by swirling, cool under the tap or in ice water, then transfer to a 50.0 ml volumetric flask. Cool again and make to mark. Read the optical density in a 10.0 mm cell with a Beckman DU spectrophotometer against a reagent blank of 23% ethyl alcohol, treated similarly, at a wave length of 580 $m\mu$ and a slit width of ca 0.05 mm.

EXPERIMENTAL

Preliminary experiments showed that the absorption peak of the spectral transmittance curve occurs at a wave length near 580 $m\mu$ (Fig. 1). Since most of the investigators recommended further heating of the al-

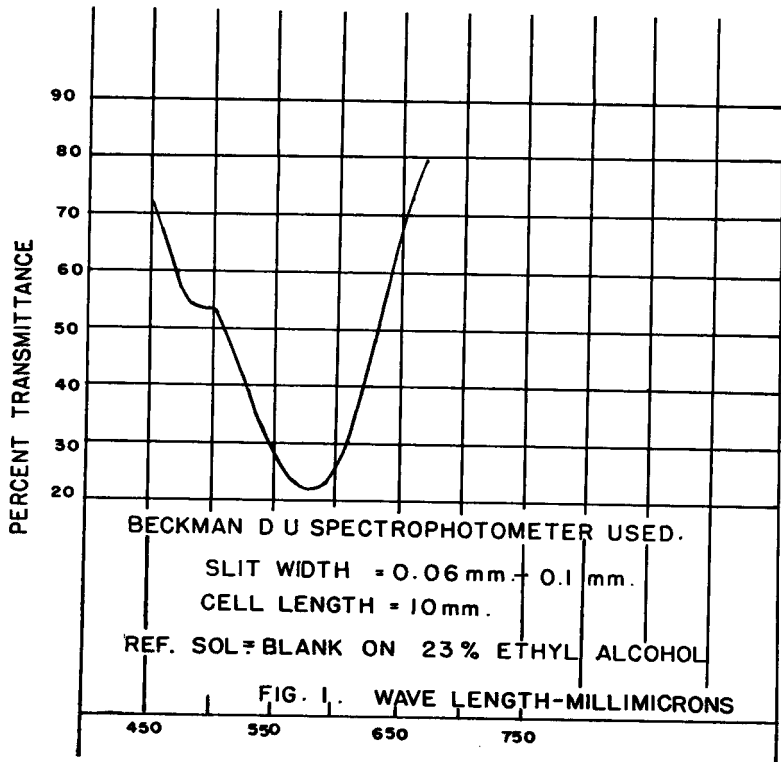

ready hot sulfuric acid solution, this procedure was at first applied. However, in each instance the violet-colored solution turned brown. In order to trace, if possible, the source of this brown color, a dilute aqueous solution of formaldehyde was treated with chromotropic acid and sulfuric acid and then heated thirty minutes in boiling water. No brown color developed after cooling and dilution with water. Then 23.0% ethanol was oxidized according to the proposed method and treated also as proposed;

but one portion was heated for thirty minutes in boiling water while the other was not. The heated portion turned brown, while there was no noticeable change in the other. (There was no increase in color when 1.0 ml H₂O plus 0.5 ml chromotropic acid and 5.0 ml sulfuric acid was heated thirty minutes in boiling water.) Thus it appeared that the oxidizing mixture caused the brown color upon continued heating. Since Gaken-

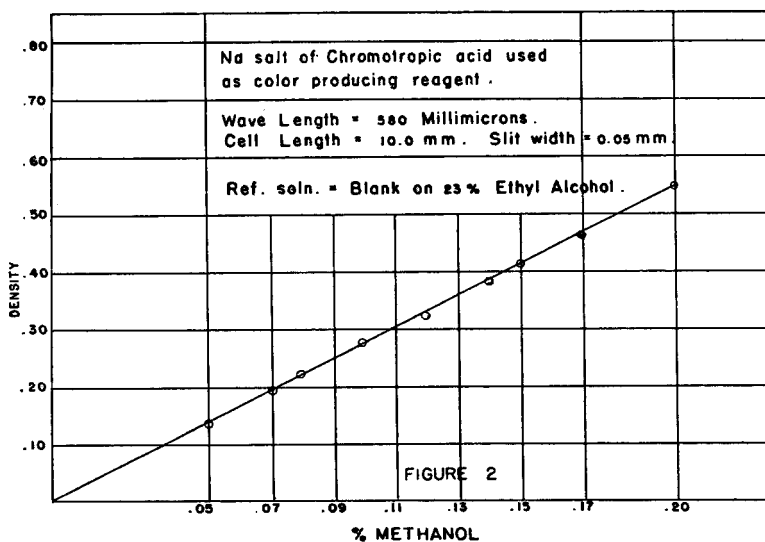

heimer and Hartung were the only investigators who mentioned the strength of the ethyl alcohol (50.0% in their experiments), a few tests were made to determine if this concentration produced the most color. A 0.1% solution by volume of methanol was prepared in 50.0% ethanol, and the same proportion in 23.0% ethanol. The two solutions were then treated by the proposed method. The 23.0% concentration of ethanol produced a 30.0 per cent increase in violet color over the 50.0% concentration.

An optical density-concentration curve was prepared by using various amounts of methanol in 23.0% ethanol. (Fig. 2). The curve shows that Beer's law is followed up to at least 0.20 per cent by volume of methanol.

In order to determine whether time of standing after the addition of the sulfuric acid has any effect on the intensity of the color formed, a sample was allowed to stand for ten minutes while another was cooled immediately before being transferred and made to volume. Both samples gave a density reading of 0.384.

It appeared to the author that Bricker and Johnson had sufficiently covered the subject of interfering substances, and no work was done in this connection.

A straight-line optical density-concentration curve was also obtained with the same amounts of methanol by limiting the final volume to 25.0 ml; but otherwise treating the sample the same as previously mentioned, except that 7.0 ml of sulfuric acid was used instead of 10.0 ml. This procedure limits the amount of methanol that can conveniently be determined to 0.17% by volume as any more would produce colors too dense for ready spectrophotometric measurement. Another disadvantage is that the 7.0 ml of sulfuric acid would have to be carefully measured, as acid concentration in this range is critical. When 10.0 ml of acid is added to the 0.17% methanol sample, there is considerably more color developed than can be measured on the instrument. When the recommended procedure is followed, with the 50 ml final volume, the 10.0 ml of the sulfuric acid does not have to be measured accurately, because this quantity is past the critical stage.

Bricker and Johnson report the color to be stable for at least 48 hours. The transmittance of one sample was measured in the afternoon and again the next morning and was found to have lost 0.5 per cent.

CONCLUSIONS

In view of the above investigation, it appears that the proposed procedure for methanol in distilled spirits is at least as accurate as the modified Denige's method, much more rapid, and the color is much more stable. A spectrophotometer or colorimeter is not essential in making this determination, as visual comparisons can be made with standard solutions of methanol.

REFERENCES

- (1) EGRIWE, EDWIN, *Z. Anal. Chem.*, 110, 22-25 (1937).
- (2) GAKENHEIMER, WALTER C., and HARTUNG, WALTER H., *J. Am. Pharm. A88'n* 30, 49-50 (1941).
- (3) BRICKER, CLARK E., and JOHNSON, HILDING R., *J. Ind. Eng. Chem. Anal. Ed.*, 17,400-402 (1945).
- (4) Boos, R. N., *Anal. Chem.*, 20, 964-5 (1948).

A TECHNIQUE FOR INFRARED ANALYSIS OF SOLIDS INSOLUBLE IN NONPOLAR SOLVENTS

By M. DOLINSKY (Division of Cosmetics, Food and Drug Administration, Federal Security Agency, Washington, D. C.)

In recent years the infrared spectrophotometer has become an extremely important and widely used analytical tool. In a literature review for the year 1950, Gore (1) lists approximately 350 papers dealing with various phases of infrared spectroscopy. Thus the basic principles and applications of infrared spectroscopy, both qualitative and quantitative, have been well described.

A variety of techniques have been used for the study of various types of material. Infrared spectra may be obtained from gases, from thin films of liquids, from solid films obtained by fusing the material or by evaporating a solution of the material, from mulls of solid material in mineral oil or other media, or from solutions of material in a suitable solvent. Spectra obtained from solutions are most suitable for quantitative studies, but application of this technique is limited because there are very few solvents that do not themselves strongly absorb infrared radiation. In the 2-15 μ range, carbon disulfide and carbon tetrachloride are sufficiently transparent over extended regions; a few other solvents such as chloroform and acetonitrile are useful over limited regions. Suitable solvents are particularly lacking in the important "fingerprint" region of 7-15 μ . In this portion of the spectrum, carbon disulfide is by far the most useful solvent. With the development of double beam infrared spectrophotometers the useful range of the various solvents has been somewhat extended; however, from the practical standpoint, carbon disulfide, carbon tetrachloride, and to a lesser extent a few other nonpolar solvents, remain the only solvent media suitable for use in infrared analysis.

Thus, while infrared spectrophotometry has been widely employed in the quantitative analysis of solids that are soluble in carbon disulfide or carbon tetrachloride, very little quantitative work has been done on materials insoluble in these or similar solvents. In some cases, it has been possible to convert the material to a soluble derivative; where this is not feasible it is necessary to work with solid films or mulls (2). Although some quantitative work has been attempted using these, technical difficulties tend to make these techniques impractical for general use.

It is known (3) that true infrared absorption curves can be obtained from solids provided the diameter of the particles of the material is considerably less than the wave length of the radiation employed. If, therefore, a uniform, stable fluid suspension of particles of less than 3 μ in diameter can be prepared, the suspension will serve as well as a solution for infrared analysis at wave lengths above 7 μ .

In connection with infrared studies of coal-tar colors and their intermediates, a technique has been developed by which quantitative infrared data may be obtained from suspensions of finely divided solids in carbon disulfide, carbon tetrachloride, or other nonpolar solvents. The suspensions are prepared by dispersing the material in the presence of aluminum stearate,¹ a suspending agent used in the paint and varnish industry (4).

In some cases, the aluminum stearate appears to act as a solubilizing agent as well as a suspending agent. For example, when 250 mg of salicylic acid was shaken with 250 mg of aluminum stearate in 25 ml of CCl_4 , the salicylic acid appeared to dissolve completely; no particles were visible

¹ Aluminum stearate was found to be a very satisfactory suspending and solubilizing agent; so considerable number of other metallic soaps may be used.

on microscopic examination. Ordinarily, salicylic acid is not soluble to this extent in CCl_4 at room temperature.

The procedure employed in the preparation of the suspensions may be outlined as follows: The sample to be analyzed plus 250 mg of powdered aluminum stearate is placed in a 125 ml glass-stoppered Erlenmeyer flask; 25 ml. of CS_2 or CCl_4 is added to the flask and the mixture is heated to boiling. The flask is quickly cooled and approximately 50 ml of 3-5 mm glass beads are added. The stoppered flask is shaken vigorously for 20-60 minutes in an automatic shaking device. (The shaking time required depends on the nature of the material and the efficiency of the shaker.) The suspensions are viscous liquids, but are sufficiently fluid to be injected into the rocksalt cells with a hypodermic syringe. If desired, a 1% solution of aluminum stearate in CS_2 or CCl_4 may be prepared in advance and used directly as the solvent.

The maximum amount of material that can be satisfactorily suspended by a given concentration of aluminum stearate appears to vary with the nature of the material. It appears that the optimum concentration of aluminum stearate is about 10 mg. per ml of solvent when 0.5 mm cells are used in the spectrophotometer. In some cases where the concentration of material exceeded the concentration of suspending agent, it was found that satisfactory suspensions could not be obtained.

Suspensions of organic solids prepared in this manner were found to be perfectly stable for at least one-half hour and generally for a much longer period. On long standing, some solid material may settle out; this can generally be readily re-suspended by shaking the flask by hand for a few seconds. Microscopic examination² of suspensions of sucrose and sulfamerazine in CS_2 prepared by the above procedure showed the majority of the particles to be less than 3 μ in diameter; however, a few particles up to approximately 30 μ in diameter were present. The aluminum stearate blank contains no particles as large as 1 μ .

In those cases in which the amount of sample was limited, we have been able to prepare satisfactory suspensions of 50 mg of samples in 5 ml of solvent containing 50 mg of aluminum stearate.

It is, of course, necessary to compensate for the absorption due to the aluminum stearate in determining absorption spectra of suspended materials. In a double beam instrument this is easily done by placing the aluminum stearate "blank" in the comparison cell. If a single beam instrument is employed, a "blank" determination must be made and deducted.

All infrared data in this paper were obtained on a Perkin-Elmer Model 21 infrared spectrophotometer.

² By A. H. Tillson, Division of Microbiology, Food and Drug Administration.

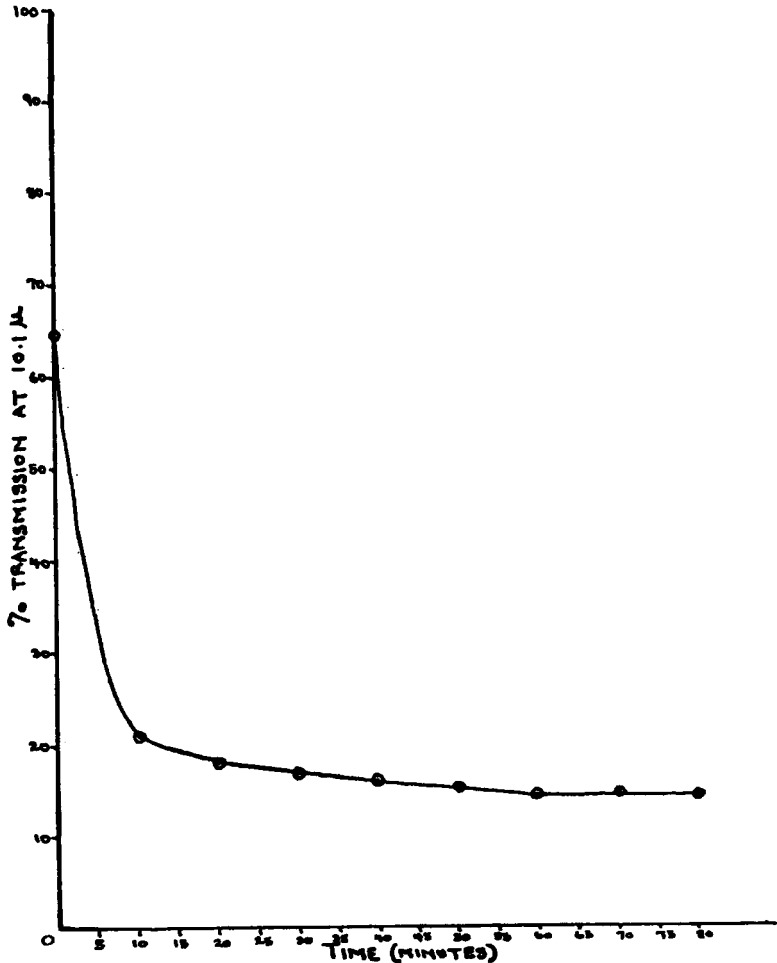

FIG. 1.—Effect of shaking time on transmission of sucrose suspension in CS_2 .

EXPERIMENTAL DATA

In Figure 1, transmission for a typical suspension after various periods of shaking is plotted. Similar data should be obtained for each system examined.

Figures 4 and 5 illustrate the change in intensity of absorption peaks with change in particle size. As the particle size decreases, the absorption peaks increase in intensity; however, the increase is not uniform for all peaks. It is apparent from this data that quantitative results by the use of

TABLE 1.—Applicability of Beer's law

(A) "Dulcin" $\text{NH}_2\text{CONHC}_6\text{H}_4\text{OC}_2\text{H}_5$

conc. (mg/ml)	ABSORBANCY (As) AT:													
	3.10 μ		7.42 μ		7.74 μ		8.08 μ		9.00 μ		9.55 μ		12.25 μ	
	As	As/mg/ml	As	As/mg/ml	As	As/mg/ml	As	As/mg/ml	As	As/mg/ml	As	As/mg/ml	As	As/mg/ml
6.0	0.263	0.044	0.255	0.043	0.178	0.030	0.554	0.092	0.263	0.044	0.205	0.034	0.216	0.036
8.0	0.343	0.043	0.342	0.043	0.223	0.028	0.793	0.089	0.331	0.041	0.265	0.033	0.259	0.032
10.0	0.500	0.050	0.429	0.043	0.293	0.029	0.970	0.097	0.411	0.041	0.318	0.032	0.337	0.034

(B) Sucrose

conc. (mg/ml)	ABSORBANCY (As) AT:									
	3.02 μ		7.47 μ		8.90 μ		9.86 μ		11.00 μ	
	As	As/mg/ml	As	As/mg/ml	As	As/mg/ml	As	As/mg/ml	As	As/mg/ml
5.0	0.400	0.080	0.128	0.026	0.257	0.051	0.246	0.049	0.234	0.047
7.5	0.598	0.080	0.192	0.026	0.381	0.051	0.364	0.049	0.344	0.047
10.0	0.724	0.072	0.255	0.026	0.490	0.049	0.476	0.048	0.455	0.046

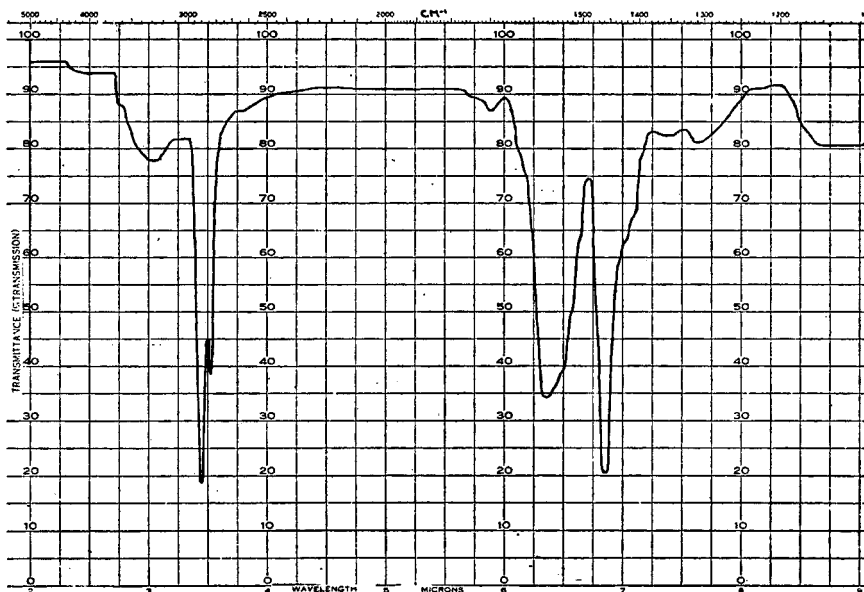

FIG. 2.—Aluminum Stearate
 Conc: 10.0 mg./ml.
 Solvent: Carbon tetrachloride
 Cells: 0.5 mm.

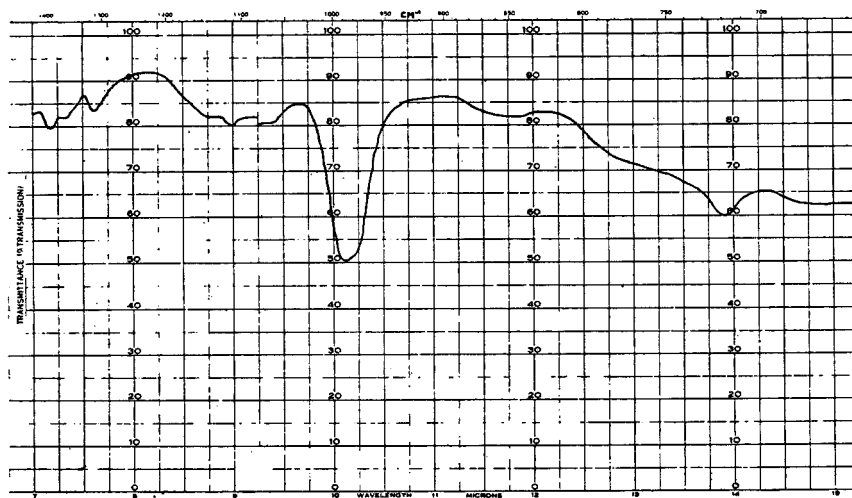

FIG. 3.—Aluminum Stearate
 Conc.: 10.0 mg./ml.
 Solvent: Carbon Disulfide
 Cells: 0.5 mm.

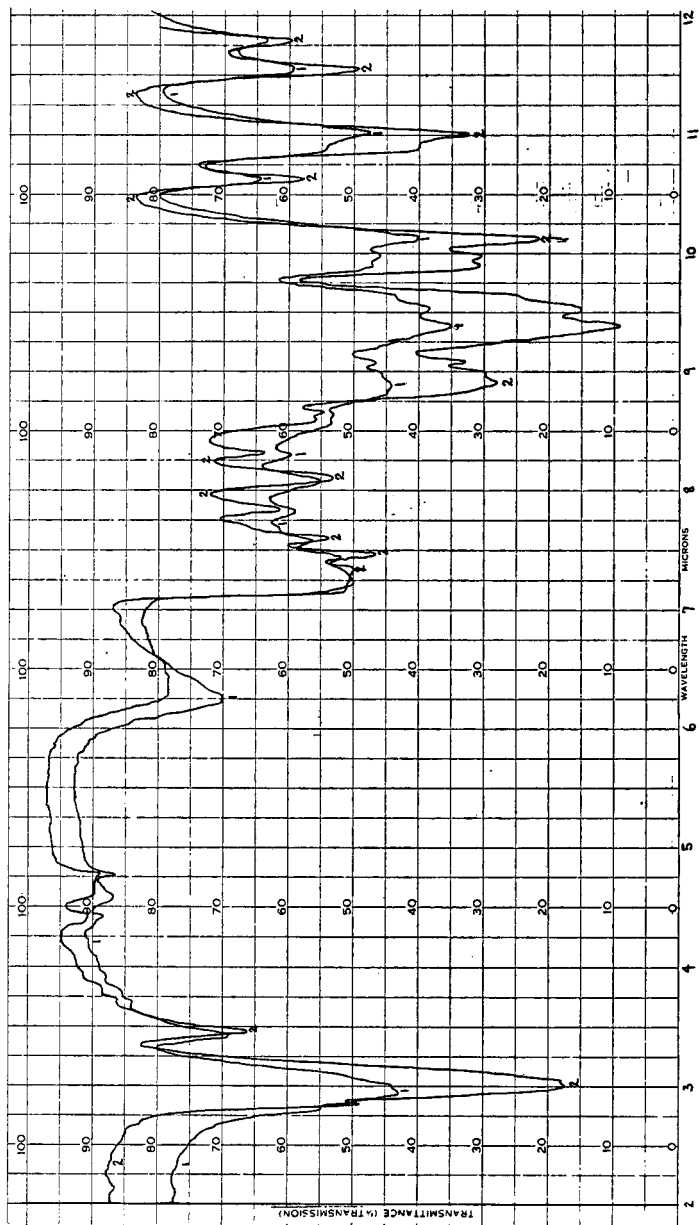

Fig. 4.—Sucrose

Conc.: 10.0 mg./ml.

Suspended in Carbon Disulfide

Cells: 0.5 mm.

Curve 1—Material passed through 400 mesh sieve.

Curve 2—Material passed through 400 mesh sieve and shaken with glass beads for 35 minutes.

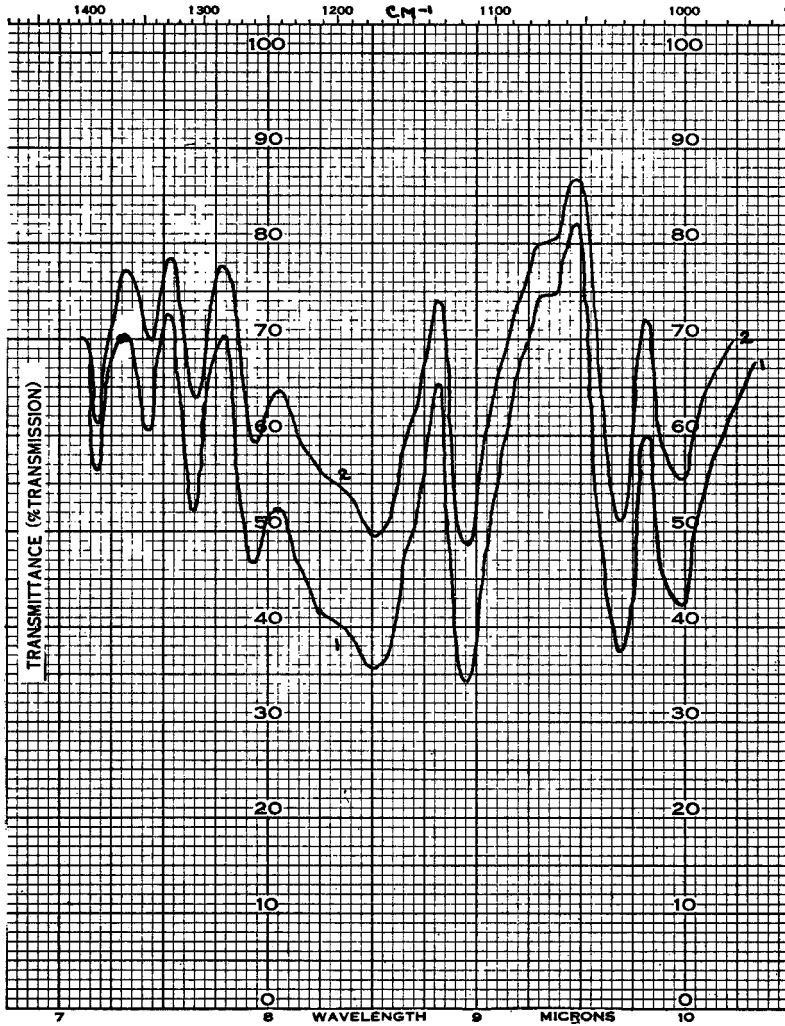

FIG. 5.—FD&C Orange No. 1 (Orange I)

Conc.: 10.0 mg./ml.

Suspended in CS_2

Cells: 0.5 mm.

Curve 1—Material passed through 400 mesh sieve.

Curve 2—Material passed through 200 mesh sieve.

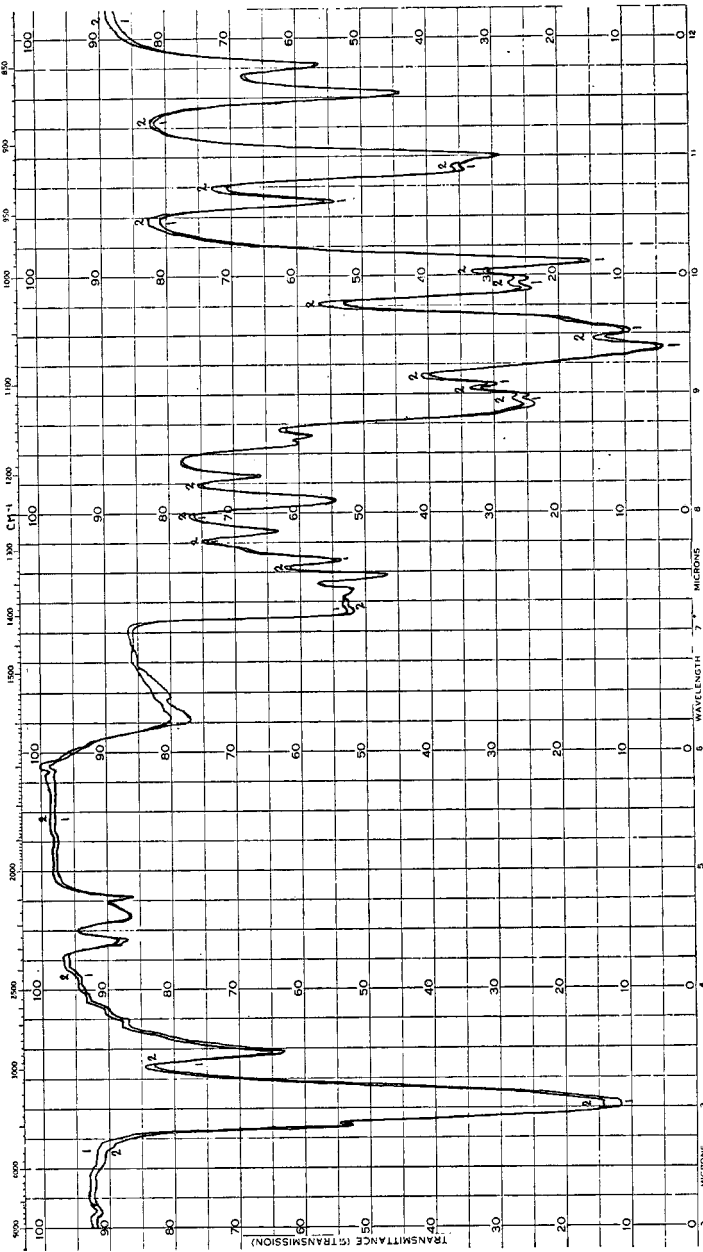

Fig. 6.—Sucrose

Conc.: 10.0 mg./ml.

Suspended in CS_2

Cells: 0.5 mm.

Shaking time: 1 hour

Curve 1—Material passed through 120 mesh sieve

Curve 2—Material passed through 400 mesh sieve

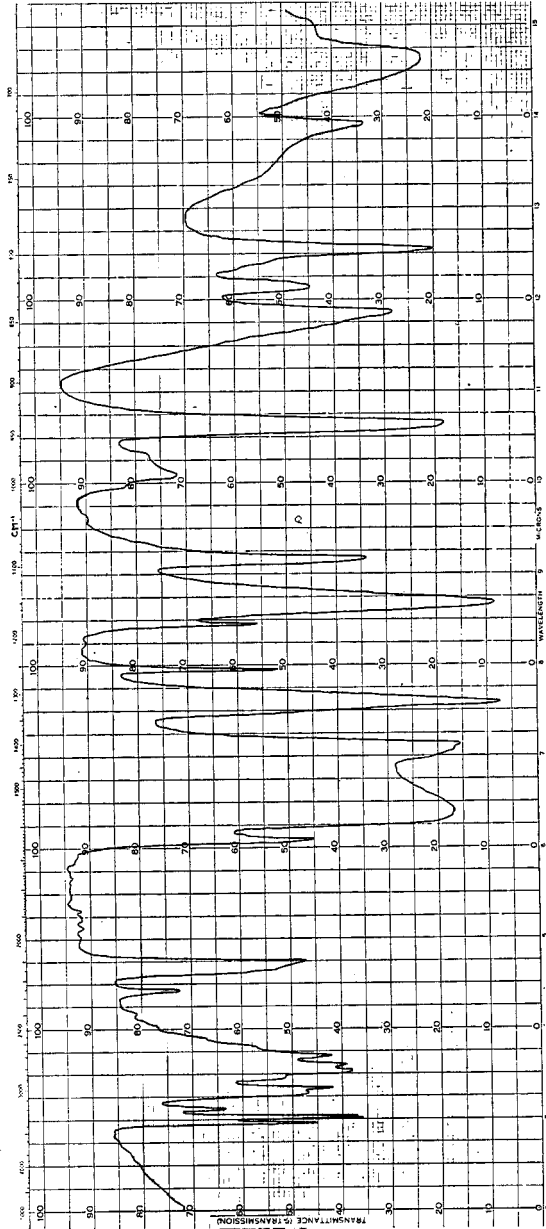

FIG. 7.—Sulfadiazine
Conc.: 10.0 mg./ml.
Suspended in CS₂
Cells: 0.5 mm.

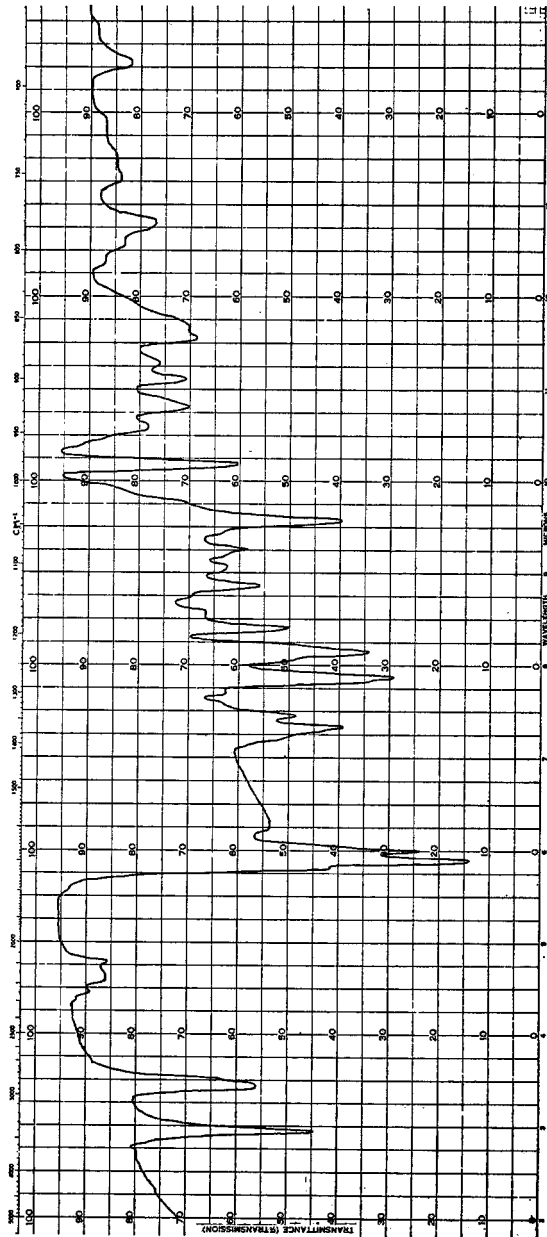

Fig. 9.—Cortisone
Conc.: 10.0 mg./ml.
Suspended in CS₂
Cells: 0.5 mm.

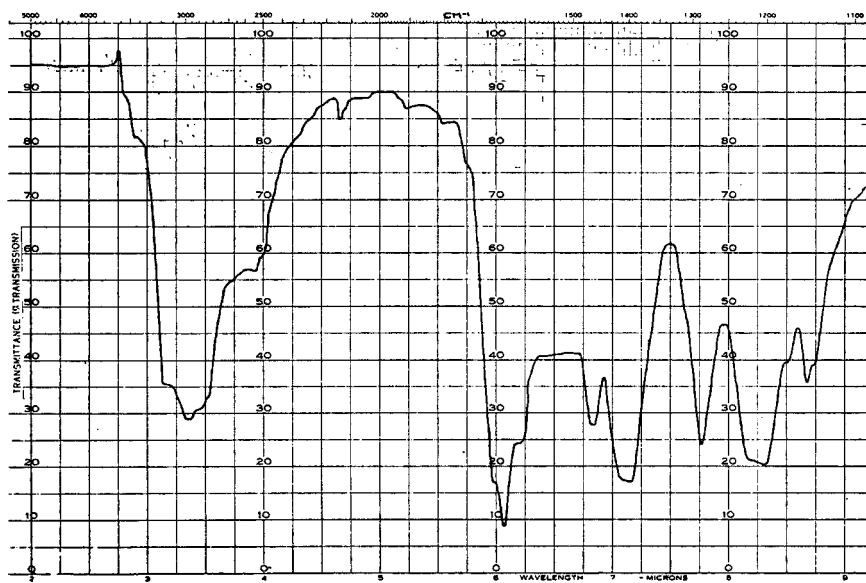

FIG. 8.—Salicylic Acid
 Conc.: 10.0 mg./ml.
 Suspended in Carbon Tetrachloride
 Cells: 0.5 mm.

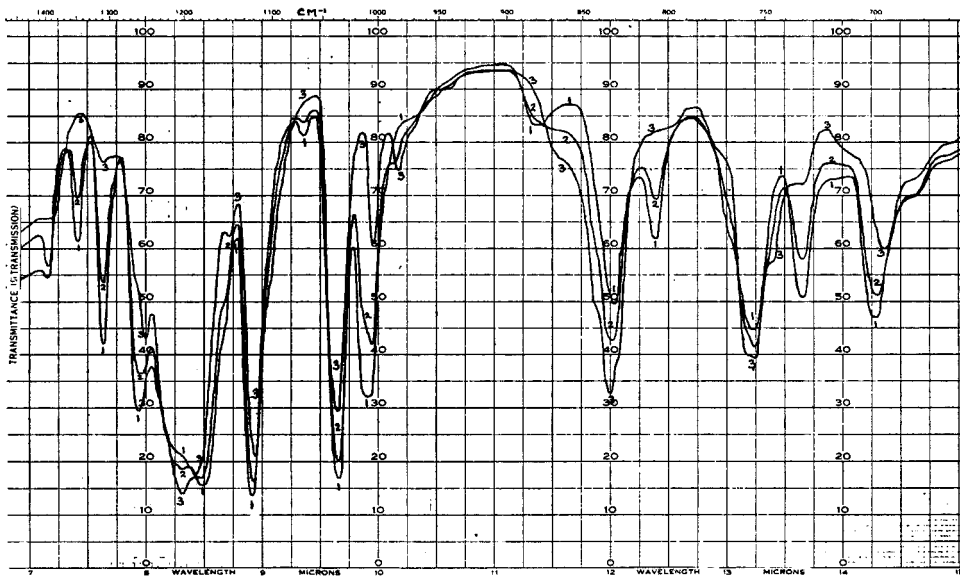

FIG. 10.—FD&C Orange No. 1, D&C Orange No. 4, and Mixture.
 Conc.: 10.0 mg./ml.
 Suspended in CS₂
 Cells: 0.5 mm.
 Curve 1—FD&C Orange No. 1
 Curve 2—Mixture $\left\{ \begin{array}{l} 60\% \text{ FD\&C Orange No. 1} \\ 40\% \text{ D\&C Orange No. 4} \end{array} \right.$
 Curve 3—D&C Orange No. 4

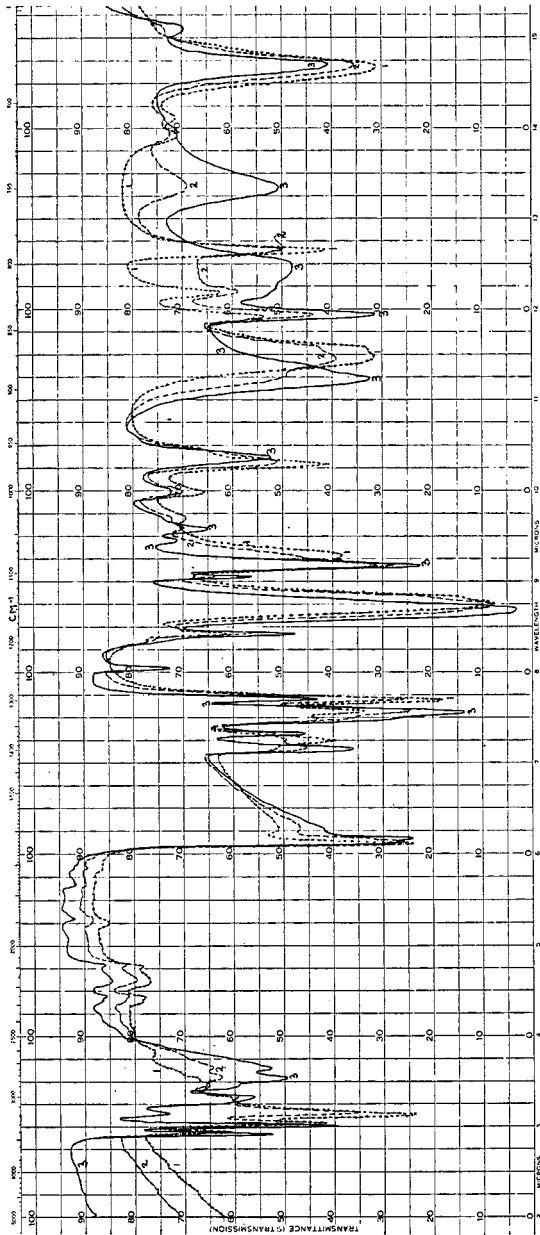

Fig. 11.—Sulfamethazine, Sulfamerazine, and Mixture

Conc.: 10.0 mg./ml.

Suspended in CS₂

Cells: 0.5 mm.

- Curve 1 Sulfamethazine
- Curve 2 — — — Mixture { 60% Sulfamethazine
- Curve 3 ——— Sulfamerazine { 40% Sulfamerazine

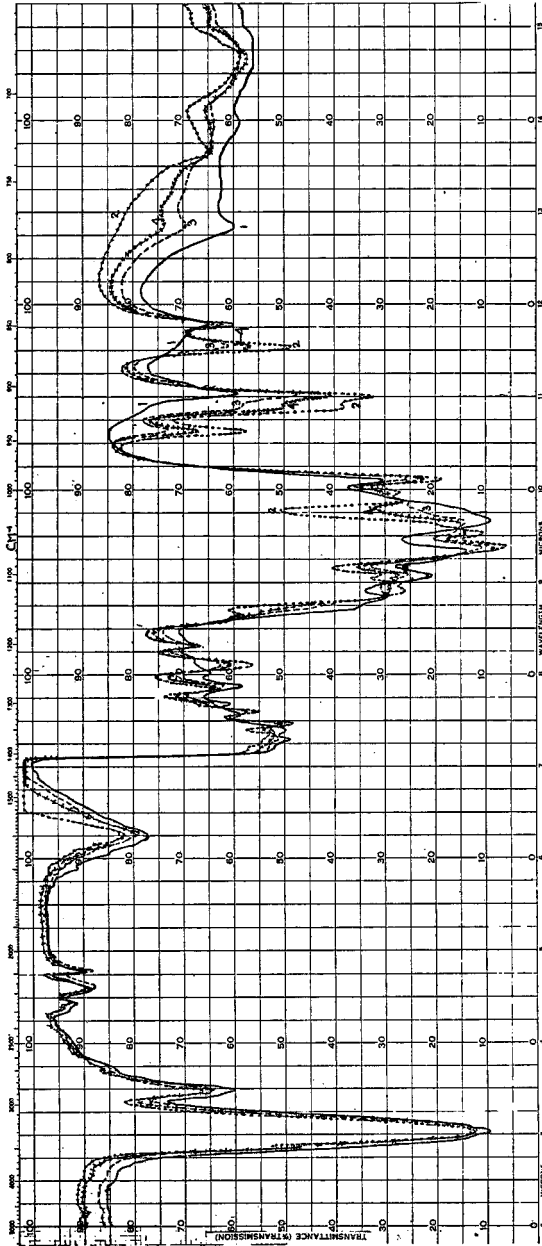

Fig. 12.—Sucrose, Maltose, and Mixtures

Conc.: 10.0 mg./ml.

Suspended in CS₂

Cells: 0.5 mm.

- Curve 1 ——— Maltose
- Curve 2 Sucrose
- Curve 3 - - - Mixture (60% Maltose, 40% Sucrose)
- Curve 4 ×××× Mixture (40% Maltose, 60% Sucrose)

TABLE 2.-Analyses of mixtures

FD&C Orange No. 1-D&C Orange No.4 (See Figure 10)		
	FD&C ORANGE No.1	D&C ORANGE No.4
	<i>per cent</i>	<i>per cent</i>
Actual Composition	60.0	40.0
Compo calc. from absorbancies at 7.63 μ	59.8	40.2
Compo calc. from absorbancies at 13.65 μ	62.6	37.3
Sulfamethazine-Sulfamerazine (See Figure 11)		
	SULFA- METHAZINE	SULFA- MERAZINE
	<i>per cent</i>	<i>per cent</i>
Actual Composition	60.0	40.0
Compo calc. from absorbancies at 9.30 μ	60.2	39.8
Compo calc. from absorbancies at 11.25 μ	57.4	42.6
Compo calc. from absorbancies at 12.65 μ	61.3	38.7
Compo calc. from absorbancies at 13.35 μ	63.8	36.2
Sucrose-Maltose (See Figure 12)		
	<i>per cent</i>	<i>per cent</i>
Actual Composition (A)	40.0	60.0
Compo calc. from absorbancies at 9.75 μ	39.3	60.7
Compo calc. from absorbancies at 10.88 μ	39.4	60.6
Compo calc. from absorbancies at 11.53 μ	40.7	59.3
Actual Composition (B)	60.0	40.0
Compo calc. from absorbancies at 9.75 μ	62.9	37.1
Compo calc. from absorbancies at 10.88 μ	61.0	39.0
Compo calc. from absorbancies at 11.53 μ	60.5	39.5

mulls can be obtained only when the particles are of uniform size in suspensions of both standards and unknowns, or when the particles are ground to a size considerably smaller than the wave length of the radiation used in the analysis.

Suspensions prepared as described appear to follow Beer's law at all wave lengths above 7 μ if measurements are made after sufficient shaking. Two sets of data obtained in experiments designed to test the adherence of suspensions to Beer's law are shown in Table 1.

In Figures 2 and 3 are shown the absorption curves of aluminum

stearate in CCl_4 (2-9 μ) and in CS_2 (7.25-15 μ). The aluminum stearate absorption peaks center at approximately 3.45, 6.35, 6.85, and 10.15 μ . It is apparent that except for these regions the suspending agent will not contribute appreciably to the absorption due to the solvent alone.

Figure 6 shows spectral curves obtained when the procedure was applied to two samples of sucrose of different particle size. The two spectral curves are almost identical. Apparently, the final particle size obtained was independent of the particle size of the original samples.

Figures 7, 8, and 9 show qualitative curves obtained by this procedure. The peaks are sharp and symmetrical; there is little background absorption.

Figures 10, 11, and 12 show spectral curves of two compounds as well as curves obtained from known mixtures of the two. In general, except at the shorter wave lengths, the absorption curves of the mixtures pass through the points of intersection of the curves of the components; this indicates that the procedure is quantitative. The results obtained in the analysis of several mixtures by this procedure are shown in Table 2.

SUMMARY

A technique is outlined for obtaining quantitative infrared spectral curves of solids insoluble in nonpolar solvents. The technique is relatively simple and appears to be applicable to a wide variety of materials that can be reduced to a very fine powder. Quantitative analyses have been performed on such widely differing materials as sugars, sulfonated coal-tar colors, sulfa drugs, and amino acids. Other materials on which excellent infrared curves were obtained include organic acids, purines, inorganic salts, penicillin and other antibiotics, and liquids such as polyethylene glycol. The procedure does not appear to be applicable to fibrous materials such as cellulose acetate, or to high molecular weight materials such as gelatine which apparently tend to absorb the aluminum stearate.

Spectral curves obtained by this technique show little evidence of light scattering at wave lengths above 7 μ . No base-line corrections are necessary in quantitative analyses.

Quantitative analysis of several mixtures by this proposed technique gave satisfactory results.

REFERENCES

- (1) GORE, R. C., *Analytical Chemistry*, 23, 7-9 (1951).
- (2) BARNES, R. B. *et al.*, *Ibid.*, 19, 620-27 (1947).
- (3) HUNT, J. M., WISHERD, M. P., and BONHAM, L. C., *Ibid.*, 22, 1478-97 (1950).
- (4) MEISTER, W. F., *U. S. Patent*, 2, 113,539 (April 5, 1938).

NOTES

CHROMATOGRAPHIC SEPARATION AND DETERMINATION OF SOME ORGANIC THIOCYANATES IN INSECTICIDE PRODUCTS.

By BOYD L. SAMUEL, Division of Chemistry, Virginia Dept. of Agriculture, Richmond

Elmore (1) has published a method for the determination of thiocyanate nitrogen, but this method does not identify the source of the thiocyanate nitrogen. Furthermore, the factors for converting the thiocyanate nitrogen to the organic compounds currently being used in insecticidal formulations are rather large. Thus, a deviation of 0.01% on the thiocyanate nitrogen determination will result in a difference of about 0.15% to 0.21% on the organic compounds later named, with the exception of BB'Dithiocyano diethyl ether, which will have a variance of about 0.07%. The Harris (2) method for the chromatographic determination of the gamma isomer of benzene hexachloride has been in use in this laboratory and has been found to give excellent results. It was thought that the organic thiocyanates might be separated chromatographically, and the Harris (2) procedure was tried on the technical grade of the following compounds which are used extensively in insecticide products:

- (A) B-thiocyano ethyl esters of aliphatic fatty acids whose average carbon content is from 10 to 18,
- (B) Isobornyl thiocyanacetate,
- (C) B-butoxy B'thiocyano diethyl ether,
- (D) BB' dithiocyano diethyl ether.

Preliminary experiments indicated that compounds (A), (B), and (C) traveled through the column in rather broad bands but were widely separated from each other. Compound (D) did not appear to be soluble in the mobile solvent and could not be chromatographed. Further work was done on the first three compounds using the Harris (2) procedure with the following changes:

First, a 5 ml aliquot of sample was used in order to obtain a sharper separation of the bands; Second, just before adding the sample a $\frac{3}{4}$ inch circle of filter paper was dropped into the column, and the sample was allowed to drain from a pipette directly on the paper, thereby preventing any disturbance of the silicic acid; Third, a shorter column (25 gm silicic acid and the appropriate amount of the solvents) was used in some cases.

After the evacuation of the solvent these compounds look much like tiny droplets of water, and small quantities seem to show up better on standing a few minutes. Even one or two milligrams can easily be seen in an immaculately clean flask. When the short column of 25 gm. silicic acid was used the compounds came through in about the following way:

- Fractions 1 to 4 contained the red and violet dyes and compound (A).
- Fractions 5 to 6 were blank.
- Fractions 7 to 11 contained compound (B).
- Fractions 12, 13, and 14 were blank.
- Fractions 15 to 22 contained compound (C).
- Fractions 23 to 28 were blank.

The numbers refer to consecutive 10 ml. fractions that were collected and from which the solvent was removed by Harris' (2) procedure. The dyes used were D&C Red No. 18 and D&C Violet No.2.

It will be observed that the three compounds can be separated from each other

* Presented at the Annual Meeting of the Association of Official Agricultural Chemists, held at Washington, D. C., October 2-4, 1950.

with the 25 gram silicic acid column. However, to separate compound (A) from the oil, which is usually present, a 100 gram silicic acid column was used. Then the oil came through before the red dye, and compound (A) came out in a rather wide band between the red and violet dyes. No interference with compound (A) is expected from DDT and chlordane, since they come through the column with or directly after the red dye. Some of the isomers (not the gamma) of BHC, DDD, pyrethrins, some of the related compounds present in technical piperonyl butoxide, and some of the related products present in the technical grade of isobornyl thiocynoacetate can be expected to come through the column with compound (A). In the event any of these materials are present a sulfur or a nitrogen determination must be made on this fraction and the result calculated to compound (A). (If a sulfur determination is made the factor for converting barium sulfate to the compound is about 1, which is much more favorable than the nitrogen factor.) The error introduced, due to the presence of technical isobornyl thiocynoacetate, will be very small unless this compound is present in great preponderance over compound (A).

Compound (B) comes through the column well after the violet dye and the previously mentioned materials do not interfere, however methoxychlor and the main portion of piperonyl butoxide will come through with it, and if either of these are present a sulfur or nitrogen determination will have to be made on this fraction.

Compound (C) comes through the column after all of the previously mentioned materials and at this writing nothing has been found that interferes with it.

Compound (D) was found to be practically insoluble in the mobile solvent, therefore it does not interfere with the determination of the other three thiocyanates under discussion, but for the determination of compound (D) some other method must be used. Fortunately, the nitrogen and sulfur factors are more favorable for this compound.

Since technical materials were used, it was impossible to determine the exact per cent recovery obtained. The recovery on several runs of compounds (A) and (C) have been about 95% for (A) and about 100% for (C) of the claimed content. The recoveries of compound (B) have been somewhat above the claimed content of isobornyl thiocynoacetate. This may be due to some of the related compounds coming through the column with the isobornyl thiocynoacetate, or the product may be of higher purity than was claimed. A number of commercial formulations have been run by this procedure and good agreement with the guarantees have been found. These recoveries were obtained by collecting and weighing the fractions as in the Harris (2) procedure.

The work on this project has been rather limited; however, it indicates that the following organic thiocyanates can be separated chromatographically.

- (A) B-thiocyano ethyl esters of aliphatic fatty acids whose average carbon content is from 10 to 18.
- (B) Isobornyl thiocynoacetate,
- (C) B-butoxy B'thiocyano diethyl ether.

The final determination can be made either by weighing the collected fractions or by calculation from a nitrogen or sulfur determination.

Further work will be necessary to establish the precision of the method and to determine what other interferences may be encountered.

REFERENCES

- (1) ELMORE, JOHN W., "Determination of thiocyanate nitrogen in organic thiocyanates and mixtures," *This Journal*, 28, 363 (1945).
- (2) HARRIS, THOMAS H., "The determination of gamma-benzene hexachloride in insecticide products," *Ibid.*, 32, 684 (1949).

DETERMINATION OF NITROGEN IN CALCIUM AMMONIUM
NITRATE BY FORMALDEHYDE TITRATION

By FRANCES L. BONNER and ERNEST A. Epps, JR., Louisiana Agricultural
Experiment Station, Baton Rouge, La.

Recently, significant quantities of calcium ammonium nitrate have been brought into this country from Europe. This material consists of approximately sixty per cent ammonium nitrate and forty per cent limestone. It is guaranteed to contain 20.5 per cent nitrogen. Because of the presence of limestone direct application of the formaldehyde titration procedure cannot be made. The following modification of the formaldehyde titration procedure has been found to give good results.

Weigh a 1 gram sample into a 400 ml beaker; add 20 ml 0.5 N HCl; cover with a watch glass; and boil gently for five minutes. Wash down the watch glass and sides of the beaker; let cool; then add 150 ml of water and two drops of methyl red indicator; then titrate to the methyl red end point with 0.5 N NaOH. Complete the determination as directed in section 2.28 of the "Official Methods of Analysis of the AOAC."

Comparison of the above method with the official Devarda method is shown in Table 1. Sample A is a synthetic composed of sixty per cent C.P. ammonium nitrate and forty per cent C.P. calcium carbonate. All analyses were made in triplicate.

TABLE I.-Comparison of Devarda and modified formaldehyde titration
methods for analysis of calcium ammonium nitrate

SAMPLI	PER CENT NITROGEN	
	DEVARDA	FORMALDEHYDE
A	20.91	20.90
462	20.25	20.45
465	20.29	20.25
479	20.09	20.10
508	20.17	19.99
557	20.25	20.12
583	20.26	20.47

BOOK REVIEWS

Leaf Analysis. An authorized translation by R. L. Mitchell (Macaulay Institute for Soil Research, Aberdeen) of "Die Blattanalyse" by H. Lundegardh (Plant Physiology Institute, Uppsala-Uluna, Sweden). Hilger & Watts Ltd., Hilger Division, London, England, 1951, 176 pages, numerous illustrations, and many tables and graphs. Price 22s. 6d. net, postage 6d. extra. Also obtainable from The Jarrell-Ash Company, 165 Newbury Street, Boston 16, Mass., for \$4.75, postage prepaid.

This is a small compact volume describing results obtained by using analysis of leaves as a means of judging the nutritive status of plants and the fertilizer requirements of the soils upon which they were grown. Several different crops, which in some instances were grown in nutrient cultures and in others, in various kinds of soil, were used as test plants. Chemical as well as spectrographic methods of analysis were employed, and an automatic, "Robot" mechanism, specially designed to deal with the large number of solutions investigated by spectrographic means, is described.

Chapter I.-The Scientific Principles of Leaf Analysis-deals with the intake of ions by roots; ion antagonism; distribution of mineral matter in the plant; functions of roots and leaves; the relationship between the nutrient index in the leaves and the growth of plants; seasonal variations of nutrient storage in the leaves; and experiments concerning the relationships between soil fertility, nutrient index, and yields.

Chapter 2.-The Practical Basis of Leaf Analysis-discusses methods for selecting samples and preparing them for analysis; chemical and spectrochemical methods of analysis; the accuracy of leaf analysis and field experimentation; the effects of fertilizing with potassium, phosphorus and nitrogen, respectively, on nutrient-index values and yields; a comparison of pot and field experiments with the same soil; and an attempt to formulate mathematically the relationship between nutrient index values and yield increases after application of fertilizer.

Chapter 3.-(last chapter).-Application of Leaf Analysis to the Manurial Requirement of the Soil-as implied in the title, is devoted to a description of results obtained by using the composition of leaves as a criterion for judging fertilizer requirements of soils.

Many tables and graphical representations of experimental data are given in the text and references to more than 150 publications are cited.

This book should be of interest to botanists, plant physiologists, horticulturists, agronomists, soil scientists, and agricultural chemists.

ERWIN J. BENNE

Wines of the World. By Peter Valaer. Abelard Press Inc., New York, N.Y. 576 pages. Price \$6.50.

The narrative style of this book enables one to read it for pleasure, and in the reading to obtain a working knowledge of the wines of the world, their areas of production, processes of manufacture, chemical composition, methods of analysis, and laws and regulations governing their distribution and sale. Occasional statements such as "In the Pacific Northwest (Washington-Oregon Division) the newest and the most enthusiastic wine locality is found" and "There is something indescribably sacred about wine" reflect the personality of the author and lend a picturesque quality to the book.

It is the kind of book that will be useful in answering all sorts of questions pertaining to the wine industry, exclusive of statistics of production, and one that

suggests the need of up-to-date books of similar scope dealing with other food products such as chocolate and beverages. The chemist will find of special interest some 44 pages of chemical analyses of wines and fruit juices representing the results of years of work chiefly by the author, with methods of analysis thoroughly tested by him. Many readers will regard these data as the most valuable portion of the book.

The chapters on methods of analysis and laws and regulations are more suggestive than comprehensive, but in view of the continual revisions and amendments of these subject matters, they appear to have been dealt with at sufficient length for a book of this type. A selected bibliography is included for those who wish to pursue the subjects further. While the book was not read for typographical errors, several such were noted, specifically, "24 volumes" in place of "2.4 volumes" on page 122, and "C₂SO₄" in place of "C₂O₄" on page 150.

J. W. SALE

A Check List on Grapes and Wine. 1938-1948. By Maynard A. Amerine and Louise B. Wheeler. University of California Press, Berkeley and Los Angeles, Calif. 240 pages, Price \$5.00.

1789 titles of books and pamphlets listed alphabetically by authors comprise 214 pages of this book.

With the exception of about 300, the publications listed are those of foreign countries, with France, Germany, Italy, and Russia predominating. Although the titles have not been translated, there are usually included a few words in English regarding the subject matter. The titles are indexed not only by subjects but alphabetically by authors, editors, etc. (where not otherwise alphabetically listed) and by countries or state of publication. A bibliography is included. For those occupied in this specialized field, this book should save many hours of library work.

J. W. SALE

Soybeans and Soybean Products. Vol. II. Klare S. Markley, Editor. Interscience Publishers, Inc., 250 Fifth Ave. New York 1, N.Y. xv+541-1145 pp. Price \$11.00.

A review of Soybeans and Soybean Products, Vol. I, was published in *This Journal*, May 1951, in which the title to the chapters and authors of Vol. II were cited. As indicated in that review the final chapter on processing is in Vol. II on "solvent extraction processes." In 48 pages, the most extensive and complete coverage known to the reviewer on this subject is presented. In this rapidly expanding continuous solvent extraction process the author covers, to mention a few phases, the preparation of the soybeans, various types of solvents, and their properties, various types of extractors, meal dryers, separation of miscella, recovery of solvent, degumming, and recovery of phosphatides. Most of Vol. II is on utilization of soybean products. The chapter on lecithin extensively covers the manufacture, composition, properties, and detailed application in numerous products as margarine, baked products, chocolate, printing inks, rubber, and cosmetics, to mention only a few. The various processing steps discussed under "processing of edible soy bean oil" are common to those for other edible oils. While the discussion of each step as applied to soybean oil is valuable, the section on deodorization is worth particular emphasis. The emphasis of the chapter on "Nutritional value of soybean and soybean products" is almost entirely on fats. The biochemical and nutritional aspects deal with various fats and oils, essential fatty acids, and fat soluble vitamins, rather than specifically soybean oil. This enhances the general value of the book.

Here one might not expect to find an excellent coverage on composition, characteristics, and utilization of various types of shortenings, salad oils, and margarine under "edible soybean oil products." The portion on mechanism, prevention and retardation of reversion of soybean oil is highly recommended. Workers in the field of steroid chemistry will have special interest in the relatively short chapter on "soybean oil by-products" with 147 references largely devoted to sterols, steroidal hormones, and tocopherols of soybean oil. The use of soybean oil in surface coating compositions under "non edible soybean oil products" includes, among others, polymerization, commercial alkyd resins and the use of soybean oil in paints, varnishes and enamels. "Soybean oil meal for livestock and poultry" deals essentially with nutritional studies of feeding cattle, sheep, swine, poultry, and turkeys with various types of soybean oil meals. There is extensive references to the literature as indicated by the 263 citations. One could perhaps classify this chapter as a manual or text on the various aspects of soybean oil meal in feeding. Soybean flour, soybean grits and soybean protein have been used in various foods such as baked products, meat products, breakfast foods, soy sauce, etc., as described under "soybean protein food products." Description of the use of soybean products in such uncommon items as tofu, miso, yuba, natto., etc., is found here. "Soybean protein industrial products" covers industrial production and applications for plywood glues, coatings, adhesives, sizes, plastics, etc. Although the canning of soybeans represents a relatively small proportion of the canning industry, the short chapter on "other soybean products" will be a welcome reference on the various steps in freezing and canning of soybeans. Author and subject index for both volumes is in Vol. II.

V. E. MUNSEY

Bibliography of Standard, Tentative and Recommended or Recognized Methods of Analysis. By Analytical Methods Committee of the Society of Public Analysts and Other Analytical Chemists, W. Heffer & Sons, Ltd., Cambridge, England (1951) vii+255 pp., price 25 s. net.

The Committee has systematically arranged by subject matter a comprehensive list of recognized publications containing methods of analysis by source reference only. Under each of the materials named below, most of the usual tests applied to determine the identity and purity have been listed, showing the publication in which the method may be found. The arrangement includes the following materials:

Metals, Ferrous and Non-Ferrous; Acids, Alkalis, Salts, etc.; Cement, Clay and Building Materials; Solid Fuels; Coal Gas and Tar Products; Petroleum, Lubricants, Asphalt and Natural Gas; Minerals; Feeding Stuffs, Soils and Fertilizers; Antiseptics and Disinfectants; Insecticides and Fungicides; Water, Sewage and Sanitation; Industrial Gases; Glass and Ceramics; Explosives; Purity Standards for Inorganic and Organic Reagents; Cellulose, etc.; Leather, etc.; Rubber; Essential Oils and Spices; Resins; Paints and Varnishes; Sugars, Starches and Gums; Cereals; Meats; Dairy Products; Brewing Materials; Vitamins; Enzymes; Pharmacal and Biological Methods; and Dye Stuffs.

In addition to methods recorded in Textbooks and Journal Articles prepared by eminent author(s), the Committee refers the analyst to many recognized sources, including their own Society's publication(s), Official Methods of Analysis of the Association of Official Agricultural Chemists, American Society of Testing Materials, Purity Standards for Reagents by the American Chemical Society, British Pharmacopoeia, British Pharmaceutical Codex, U. S. Pharmacopoeia, National Formulary, British Standards Institution, U. S. National Bureau of Standards, His Majesty's Geological Survey, Methods by the American Public Health Association,

(Royal) Institute of Water Engineers, British Ministry of Health, British Ministry of Food, and other similar sources.

Despite some failures in completeness, which the Committee acknowledges, the book is a valuable reference source for methods. The arrangement of subject matter could be improved. The Committee is to be congratulated for their courage and the results of their initial publication.

A. H. ROBERTSON

Industrial Oil and Fat Products. By ALTON E. BAILEY. Interscience Publishers. New York, N. Y. 1951. Second Edition, xxiv+967 pp. Price \$15.00.

This revised and enlarged edition of a well-known reference on oil and fat products reflects the intense activity and the important technological advances in this field in the last six years. The plan and scope of this book are essentially the same in the first edition.* The first section on the nature of fats and oils and the second section on raw materials for oil and fat products remain as brief, elementary reviews of the chemical and physical properties of the raw materials and their fatty constituents. The chapter on production and consumption of primary fats and oils has been omitted in this edition.

The significant revisions in this volume appear in the augmented last two sections. In the section on the industrial utilization of fats and oils the largest expansion appears in the chapters on shortenings, butter and margarine, soap and paints. In the last section on unit processes there is a new chapter on handling, storage and grading of oils and oil-bearing materials. Practically all other chapters in this section have been enlarged, particularly those on refining and bleaching, hydrogenation, and fat splitting, esterification and interesterification.

The only minor flaws noted in this revision were retention of some outdated definitions for food products. Thus, the volume fails to note the latest standards for mayonnaise, salad dressings and french dressing, which were announced on August 12, 1950. The first edition has proved its value to all those working in the oil and fat field and this revision should be of even greater value. The high quality of workmanship and excellent presentation and printing is just as marked in this revision as in the first edition.

J. FITELSON

* See *This Journal*, 29, 115 (1946).

Saves Time!
Prevents Waste!
Economical!
Always Uniform!

MILL
CREEK

D-C DIGESTION CATALYST Ta's

For Nitrogen Determinations In *Kjeldahl* Tests

KJELDAHL-WILFARTH-GUNNING METHOD

D-C TAB No. 3

$\text{HgO} + \text{K}_2\text{SO}_4$

Two Tablets supplies the catalyst ingredient and K_2SO_4 in the quantity and proportion as specified by the A.O.A.C. for the analysis of protein by the official Kjeldahl-Wilfarth-Gunning Method. (Formerly K-G-A)

GUNNING METHOD

D-C TAB No. 2

$\text{CuSO}_4 + \text{K}_2\text{SO}_4$

One Tablet supplies the catalyst ingredient and K_2SO_4 in the quantity and proportion as specified by the A.O.A.C. for the analysis of protein by the official Gunning Method.

Write For Samples

ON LABORATORY LETTERHEAD



Produced under the supervision of a pharmaceutical chemist. Each batch is analytically tested and recorded for uniform results.

D-C Tabs are packaged in standard containers of 100, 500 and 1000. Also in special lots of 5000.



The FISHER TITRIMETER*

Standard Key
Instrument
for
Volumetric
Analysis



The eye winks conspicuously
at the exact end point.

For:
**Acid Base
Titrations**
**Oxidation
Reduction
Titrations**
**Precipitation
Titrations**

The Fisher Titrimeter* enables great accuracy of results—rapidly—and with a minimum number of manipulations. Applicable to a wide range of analyses, the Titrimeter's sensitivity is such that as little as .02 volts will *completely* open the magic eye. Direct readings are made from either a pH or volt scale, and the exact end point is unmistakably shown by the magic eye.

Fisher Titrimeter, with Manual of Directions, for
115 volt A.C. **\$310.00**

*Reg. U.S. Pat. Off.

Write for Bulletin 3L

Headquarters for Laboratory Supplies

FISHER SCIENTIFIC COMPANY

PITTSBURGH
717 Forbes (19)

• NEW YORK •
635 Greenwich (14)

• WASHINGTON •
7722 Woodbury
(Silver Spring, Md.)

• ST. LOUIS •
2109 Locust (3)

• MONTREAL
904 St. James

GEORGE BANTA PUBLISHING COMPANY, MENASHA, WISCONSIN