

# The ANALYST

A Monthly Publication  
dealing with all branches  
of Analytical Chemistry:  
the Journal of the Society  
for Analytical Chemistry

Published for the Society by  
W. HEFFER & SONS LTD., CAMBRIDGE

**Volume 84**

**No. 1000, Pages 401-472**

**July 1959**

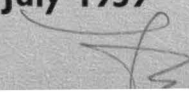

# THE ANALYST

THE JOURNAL OF THE SOCIETY FOR ANALYTICAL CHEMISTRY

---

## PUBLICATION COMMITTEE

Chairman: K. A. Williams

### Members:

N. L. Allport  
A. L. Bacharach  
B. A. Ellis, O.B.E.  
D. C. Garratt  
J. H. Hamence

J. Haslam  
H. M. N. H. Irving  
W. C. Johnson, M.B.E.  
J. I. M. Jones  
E. Q. Laws

R. F. Milton  
J. G. Sherratt  
L. S. Theobald  
T. S. West  
D. W. Wilson

and the President and Honorary Officers

President of the Society: R. C. Chirnside

Hon. Secretary of the Society:  
R. E. Stuckey

Hon. Treasurer of the Society:  
A. J. Amos

Hon. Assistant Secretaries of the Society:  
L. Brealey; S. A. Price

### Editor:

J. B. Attrill, M.A., F.R.I.C.  
14 BELGRAVE SQUARE, LONDON, S.W.1  
Telephone: BELgravia 3258

Assistant Editor:  
P. W. Shallis

---

## NOTICE TO SUBSCRIBERS

(Other than Members of the Society)

All subscriptions to *The Analyst*, including *Analytical Abstracts*, should be sent through a Bookseller or direct to

W. HEFFER & SONS LTD., CAMBRIDGE, ENGLAND

Subscriptions are NOT accepted for *The Analyst* alone

Subscriptions to *The Analyst*, together with *Analytical Abstracts* printed on one side of the paper (without index), can be accepted at £8 15s. per annum.

Subscriptions to *The Analyst*, together with *Analytical Abstracts* printed on one side of the paper (with index), can be accepted at £9 12s. 6d. per annum.

N.B.—Members send their subscriptions to the Hon. Treasurer.

Single Copies Price 15s. Post Free

Subscription Rate, inclusive of *Analytical Abstracts* and Indexes, £8 8s. per annum, post free.

Volume 84, No. 1000

July 1959

13 M.A. 2502

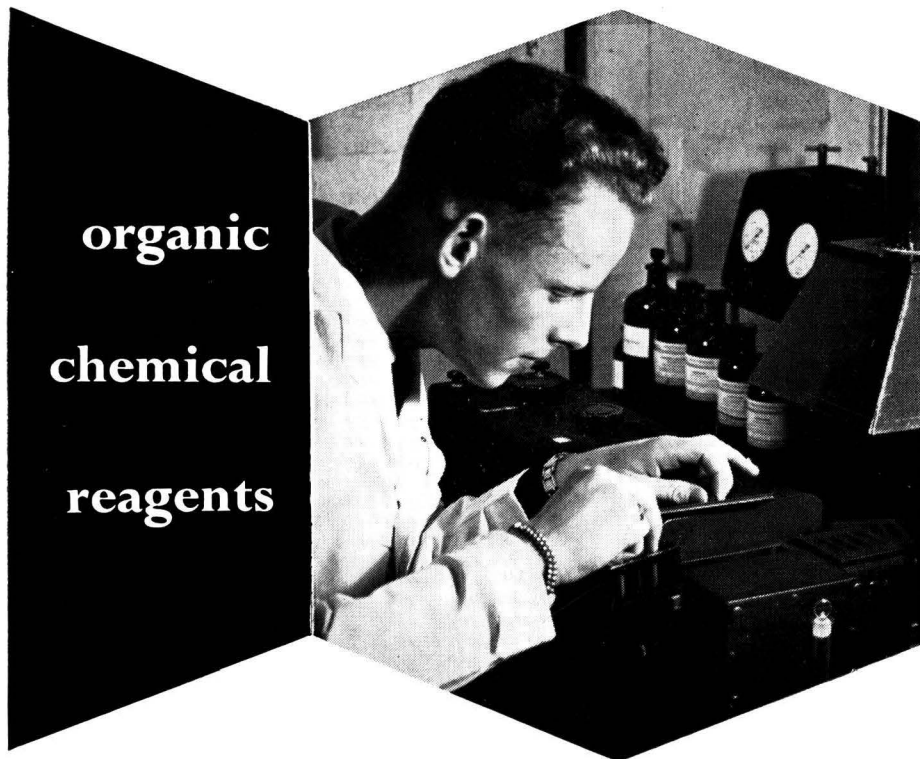

**organic  
chemical  
reagents**

These include a full range of modern reagents for metals and are the subject of a series of monographs by H & W Chemists. We direct your present attention to:-

No. 35 2:4 Xylenol, reagent for Nitrate.

No. 36 *p*-Bromomandelic Acid, reagent for Zirconium.

No. 37 Zincon, reagent for Zinc and Mercury.

—all or any of which we shall be glad to send you free. Previous monographs covering a wide range of organic reagents are available in book form under the title "Organic Reagents for Metals and other Reagent Monographs: Vol. 1" 15/- net, post free.



**FINE CHEMICALS**

*for Research and Analysis*

HOPKIN & WILLIAMS LTD., CHADWELL HEATH, ESSEX, ENGLAND  
*London, Manchester, Glasgow*

*Agents throughout U.K. and all over the world*

# B.T.L. TEST-KIT

## for Pentachlorophenates

This is a complete outfit, developed by Baird & Tatlock (London) Ltd., in collaboration with Monsanto Chemicals Ltd. and The Tintometer Ltd., for the estimation of microgram quantities sodium and copper pentachlorophenates in water.

It consists essentially of a Lovibond Comparator and Disc together with all necessary apparatus and reagents. It is compact and portable (weight approx. 9 lbs.), is very suitable for field work and can be used by relatively unskilled operators.

The test-kit will be of interest to all concerned with the processing or preservation of Wood, Pulp, Paper, Board, Textiles, Leather etc.

*Complete outfit with instruction book, catalogue No. C7/215 : Price £21.*

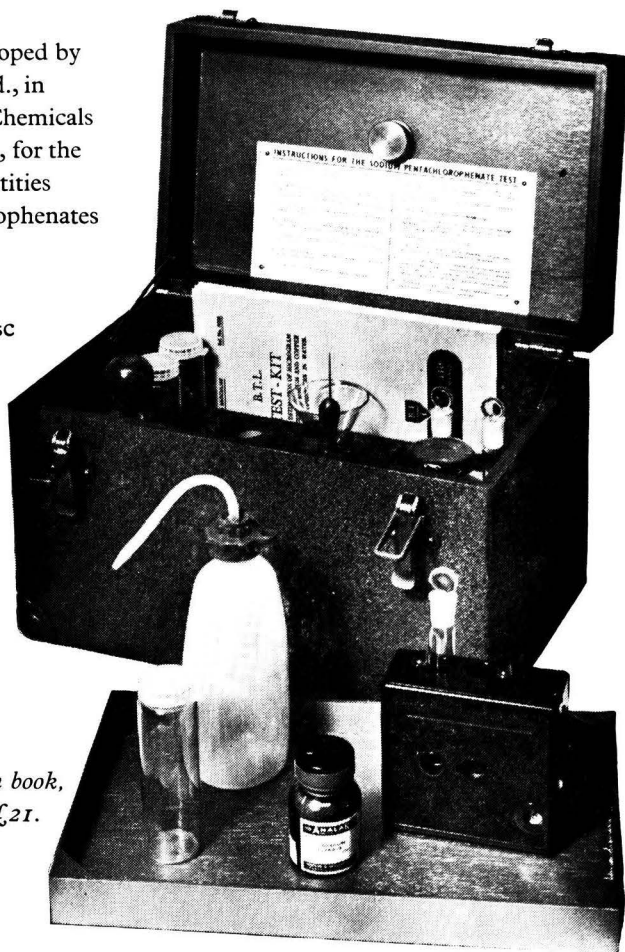

*complete laboratory service*

BAIRD & TATLOCK (LONDON) LTD., CHADWELL HEATH, ESSEX, ENGLAND.  
Branches in London, Manchester & Glasgow. Agents throughout U.K. and all over the world

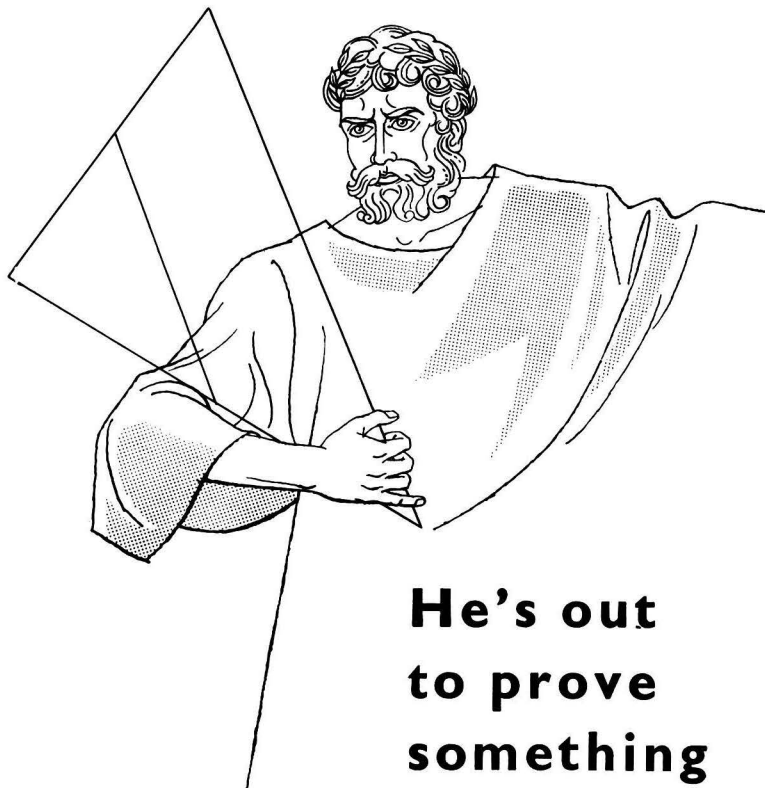

## He's out to prove something

Most of us, in our formative years had decided views that this gentleman never really deserved laurel leaves.

However, he reached some very sound conclusions.

We have a few theories also, about the installation and equipping of laboratories. If this is one of *your* problems, we may be able to help in getting that quart into a pint pot

*(Same again, please Miss !)*

## GRIFFIN & GEORGE

The Laboratory Furnishers

Griffin & George (Sales) Limited, Ealing Road, Alperton, Wembley, Middlesex. (PER 3344)

A member of the Griffin and George group of Companies.

LONDON · BIRMINGHAM · SHEFFIELD · MANCHESTER · NEWCASTLE-UPON-TYNE · GLASGOW · EDINBURGH

P1



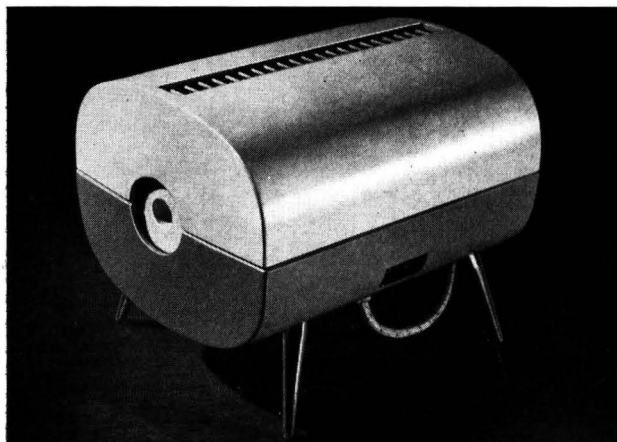

*Electric Furnace  
type K 25 B*

*for temperatures up to* **1500°C**

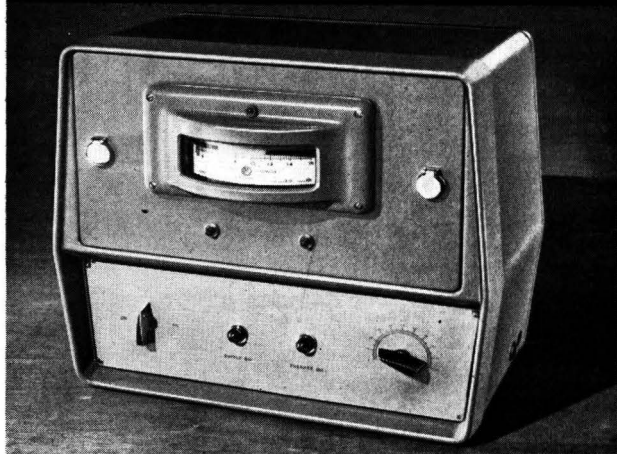

*Control Unit  
Type C 8*

The advantages of the platinum-wound resistance furnace as a source of controlled high temperature are fully realised by the JMC Model K range of furnaces. A series of data sheets describing both furnaces and control units is available on request.

**Johnson**  **Matthey**

*Information regarding the properties of  
the platinum metals and their  
industrial applications is always available*

**JOHNSON, MATTHEY & CO., LIMITED**

73-83 HATTON GARDEN, LONDON, E.C.1 Telephone: Holborn 6989

Vittoria Street, Birmingham, 1. Telephone: Central 8004

75-79, Eyre Street, Sheffield, 1. Telephone: 29212

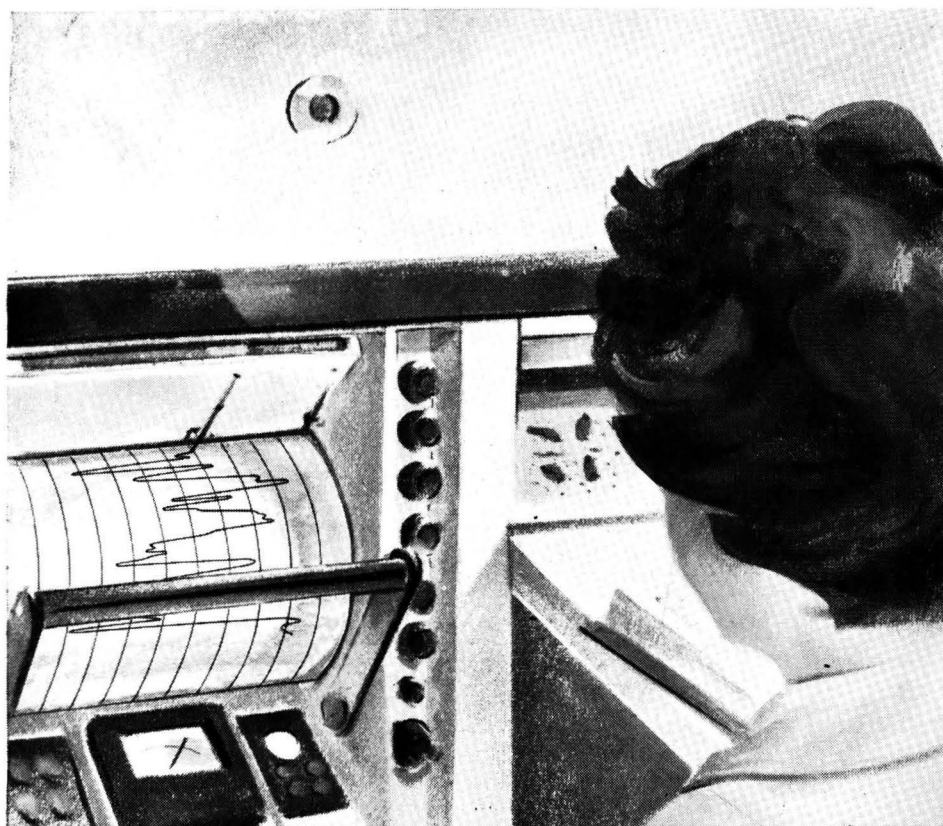

## “The Infrared Spectrum .....

“The infrared spectrum of a chemical compound is probably the most characteristic physical property of that compound.”\* From this fact has grown to-day's dependence on infrared analysis for rapid, complete information on the composition of nearly all chemical compounds.

A parallel development in infrared instrumentation has reached its peak in the Unicam SP.100 Infrared Spectrometer which offers a unique combination of performance and utility. Both technical and commercial management in many fields have been quick to recognise a powerful tool in the search for a better product—or a better way of making existing ones.

Write for a copy of a new leaflet “Economics of Infrared” which indicates some of the ways infrared spectroscopy can help a lively business keep ahead.

\* G. B. B. M. Sutherland and H. W. Thompson, *Faraday Society Transaction*, 41 175 1945.



**SP.100 Infrared Spectrometer**

**UNICAM**

UNICAM INSTRUMENTS LTD • ARBURY WORKS • CAMBRIDGE

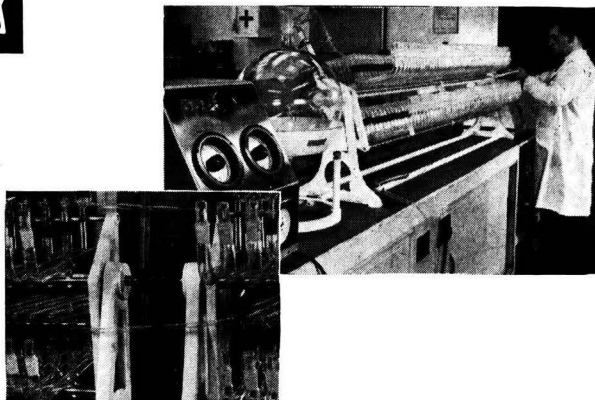

## Liquid / Liquid Extraction

### CRAIG COUNTER CURRENT MACHINES

separate complex heat-sensitive, non volatile materials in quantities sufficient for preparative work. They are used for isolating alkaloids, anti-biotics, products of metabolism and other naturally occurring plant and animal substances and compounds derived from them. The machines comprise basically a series of up to 200 separate interchangeable extraction tubes of 25 ml. phase capacity. They can be bench or trolley mounted and are powered by an 0.25 h.p. motor. The semi-automatic machines operate unattended for upwards of 75% of the time, whilst automatic models, after the initial setting, carry out the selected number of transfers and finally switch themselves off without further attention.

T  
E  
L  
E  
P  
H  
O  
N  
E

STONE 481

QUICKFIT & QUARTZ LTD., Dept. O.Z., "Quickfit" Works, Heart of STONE, Staffs.



## Atomic-absorption spectroscopy

Unaffected by flame temperature  
Determines elements not excited in the flame  
Free from inter-element effects  
High sensitivity, even with 'difficult' elements

Lead	50 p.p.m.
Magnesium	0.1 p.p.m.
Platinum	10 p.p.m.
Zinc	0.1 p.p.m.
Mercury	50 p.p.m.
Gold	1 p.p.m.

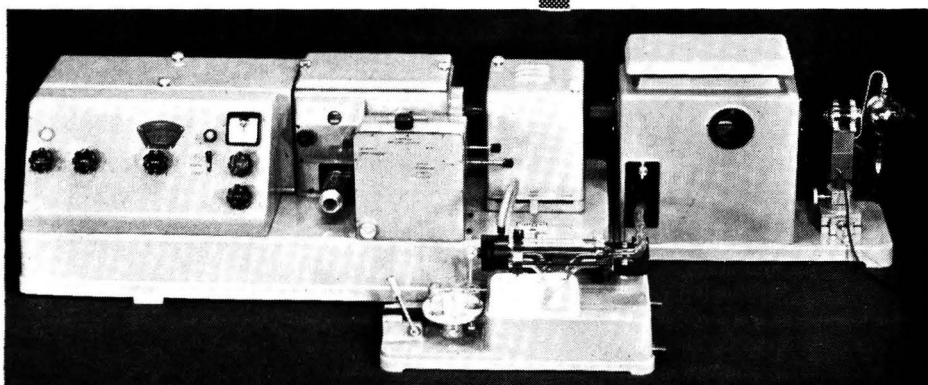

The Hilger atomic-absorption equipment can be used with the Uvispek, and spectrophotometer with a similar performance. Please send for full details.



98 ST PANCRAS WAY · LONDON · N.W.1

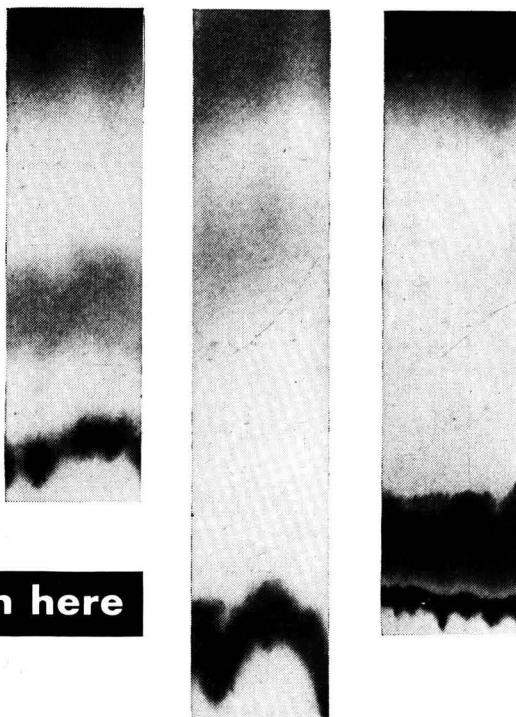

**our reputation here**

### **extends to every Whatman Filter Paper**

As with Whatman Papers for chromatography . . . so with those for **routine filtration**. All Whatman Filter Papers are manufactured to the unvarying high standard that has made the chromatography range renowned the world over. Critical attention is given to the quality of the raw materials . . . production control is in the hands of technicians and craftsmen who can call on more than a century's experience of first-class papermaking. It is the result of their skill that completely reliable papers of different physical properties can be supplied for all routine filtration procedures. The range is discussed in the "Filtration Section" of the Whatman catalogue.

*Please write for a copy of this and of the "Buyers' Guide." You will find them a useful guide to routine laboratory practice.*

**H. REEVE ANGEL & CO. LTD**

9 BRIDEWELL PLACE, LONDON EC4    also at 52 DUANE STREET, NEW YORK 7

*sole distributors of*

# WHATMAN FILTER PAPERS

Manufacturers W. & R. Balston Ltd



This one  
address  
is the key

**S I M A**

**INSTRUMENT CENTRE**

20 QUEEN ANNE STREET, LONDON, W.1  
Telephone: IMPerial 6000  
(Press enquiries: LANgham 4251)

Here the whole world can find the finest scientific instruments, key information and prompt advice.

- ★ Electronic and nuclear instruments
- ★ Navigational and survey equipment
- ★ Optical and ophthalmic instruments
- ★ Laboratory, medical and X-ray apparatus
- ★ Instruments for process control and automation
- ★ Kinematograph and allied instruments
- ★ All industrial instrumentation

THE SCIENTIFIC INSTRUMENT MANUFACTURERS ASSOCIATION OF GREAT BRITAIN

Space presented by L. OERTLING, LTD., St. Mary Cray, Kent.

# Judactan

analytical reagents

with actual  
batch analysis

## SODIUM CARBONATE A.R.

$\text{Na}_2\text{CO}_3$

ANHYDROUS

Mol. Wt. 105.99

### ACTUAL BATCH ANALYSIS

(Not merely maximum impurity values)

Batch No. 32815

Ammonia ( $\text{NH}_3$ )	0.00008%
Arsenic ( $\text{As}_2\text{O}_3$ )	0.00001%
Chloride (Cl)	0.0003%
Copper (Cu)	0.00002%
Heavy Metals (Pb)	0.00003%
Iron (Fe)	0.00004%
Nitrate ( $\text{NO}_3$ )	0.0005%
Phosphate ( $\text{PO}_4$ )	0.0003%
Silicate ( $\text{SiO}_2$ )	0.003%
Sulphate ( $\text{SO}_4$ )	No reaction

The above analysis is based on the results, not of our own Control Laboratories alone, but also on the confirmatory Analytical Certificate issued by independent Consultants of international repute

Chemists all over the world are grateful for our care. Our policy of having independent analyses made gives chemists added confidence in their work.

Why not compare the actual batch analysis shown with the purities guaranteed by the specifications to which you normally work? You will find the comparison of interest and almost certainly of help to you.

# THE ANALYST

## EDITORIAL

### The Thousand Up

JUST as our June issue was being printed, a dispute in the printing industry came to a head, and the presses all over the country were—more or less—stilled. We apologise to our readers for this hiatus in publication, and to the authors whose papers have been delayed in consequence.

Although the greater part of the June *Analyst* and *Analytical Abstracts* had been printed before the stoppage, their completion and dispatch were necessarily delayed. Nor was it possible for our apologies to be added at that late stage.

Our printers have always been particularly conscious of their responsibilities in producing a scientific journal, and have co-operated to the full in the expeditious production of this, the July, issue—the first to appear after the settlement of the dispute. We know, too, that they will make every effort to make up for lost time, and we hope to be back to our normal schedule before long.

If our overseas readers will pardon the use of a metaphor adapted from cricket, we have, after nearly being caught out at 999, at last put the thousand up.

## PROCEEDINGS OF THE SOCIETY FOR ANALYTICAL CHEMISTRY

### NEW MEMBERS

#### ORDINARY MEMBERS

Dunstan Akanni Adewale Akintonwa, M.I.M.L.T.; Adolf David Kjell Berggren, B.Sc. (Gothenburg); Carl Olof Björling, M.S. (Uppsala), B.S. (Stockholm); Stanley Gordon Coton, B.Sc. (Birm.); Richard Cox, A.R.I.C.; Geoffrey Noel Davies; Frank Oxtoby Firth, A.R.I.C.; Theodore W. Gilbert, jun., B.S. (M.I.T.), Ph.D. (Minnesota); Daniel Richard Goddard, B.Sc., Ph.D. (Lond.); Daniel Ceiriog Jenkins, M.Sc. (Lond.), D.I.C., F.R.I.C.; Ronald Edward King, A.R.I.C.; Bernard L. Oser, M.S. (Pennsylvania), Ph.D. (Fordham); Geoffrey Howard Pickerell, B.Sc. (Sheff.); Vladimir Charles Sekera, M.S. (Illinois), Antony Colin Thomas; Geoffrey Topp, B.Sc. (Manc.); Joseph Edward Patrick Treadwell, III; John Vernon Wilkinson, B.Sc. (Lond.).

#### JUNIOR MEMBERS

John Metcalfe, B.Sc. (Leeds); Ramesh Nagaratnam Mudliar, B.Sc. (Bombay), M.Sc. (Lond.), D.I.C.

### SCOTTISH SECTION

AN Ordinary Meeting of the Section was held at 7.15 p.m. on Wednesday, April 15th, 1959, in the Central Hotel, Glasgow, C.1. The Chair was taken by the Vice-Chairman of the Section, Mr. A. F. Williams, B.Sc., F.R.I.C.

The following papers were presented and discussed: "The Analytical Chemistry of Some of the Lower Phosphorus Oxyacids," by D. S. Payne, B.Sc., Ph.D., A.R.C.S., A.R.I.C.; "Qualitative Analysis by Solvent Extraction Methods," by R. A. Chalmers, B.Sc., Ph.D., and D. M. Dick, B.Sc. (see summaries below).

#### THE ANALYTICAL CHEMISTRY OF SOME OF THE LOWER OXYACIDS OF PHOSPHORUS

DR. D. S. PAYNE began by pointing out that the lower oxyacids of phosphorus covered a very large number of possible compounds based on the P-OH, P=O, P-P, P-O-P and

P-H functions, only a few of which were in fact known. To facilitate the investigation of this group of compounds, consideration had been given to the general features of the analytical chemistry of the well known lower oxyacids with a view to extending the methods to as yet unknown members.

Paper chromatography, using conventional solvents, appeared likely to be limited to the simpler compounds, or to those particularly resistant to the hydrolysis attendant on the use of water-containing solvents. The semi-quantitative analysis of mixtures of the lower oxyacids had been achieved by use of  $^{32}\text{P}$ -labelled acids, the paper being cut into sections and activity counted after separation. The high background of the paper around the spots had so far limited the development of the method.

pH titration offered a promising method of general applicability since the pK values of the -OH groups in the various environments appeared to vary according to definite rules. However, in many of the more complex acids, distinction between groups was difficult and the tendency to hydrolysis limited the method. Useful results had been obtained from the application of ion-exchange resins to the study of the alkali-metal salts of these acids.

Oxidation of the phosphites and hypophosphites had been widely studied previously, from many angles. Most of the oxidations were comparatively slow reactions. The effect of acid concentration, added phosphate, sulphate and alkali-metal ions on the rate of ceric oxidation had been studied. The ceric reaction could be catalysed by silver and other metal ions, as well as by traces of iodine. In the iodine and chloramine-T oxidation of phosphite a radical mechanism leading to hypophosphate was postulated to account for the inconsistencies observed under certain pH conditions and for the products of the reaction.

#### QUALITATIVE ANALYSIS BY SOLVENT EXTRACTION METHODS

MR. D. M. DICK gave an outline of the theory of extraction of co-ordination compounds and enumerated the properties desirable in a complex-forming reagent to be used in solvent extraction. He then gave an account of the extraction properties of four reagents, acetylacetone, oxine, sodium diethyldithiocarbamate and dithizone, when used in conjunction with the common cations of the classical qualitative scheme. From these properties a scheme had been propounded for the separation of the common cations into groups by extraction processes. The members of the groups could then be identified by further extraction reactions and colorimetric tests.

Between 30 and 500  $\mu\text{g}$  of a cation could be separated and identified in this way, and for many elements it was possible to make a semi-quantitative analysis by such methods as colorimetry or titration with EDTA. Advantages of the scheme were the freedom from effects analogous to co-precipitation and the completeness of the separations. Most of the groups cut across the groups of the classical scheme, and the two methods could be used in combination.

So far the scheme had been deliberately restricted in its scope, but information had been collected on the behaviour of other cations, and the scheme should be capable of expansion, although inclusion of other elements might necessitate a re-organisation of the order of separation.

DR. R. A. CHALMERS then gave a practical demonstration of the techniques.

#### WESTERN SECTION AND MICROCHEMISTRY GROUP

A JOINT meeting of the Western Section and the Microchemistry Group, together with the South Wales Section of the Royal Institute of Chemistry and the Swansea University College Chemical Society, was held at 6.30 p.m. on Friday, May 8th, 1959, in the University College of Swansea. It was preceded by a visit to the B.P. Refinery at Llandarcy.

Mr. P. F. Ellis, M.B.E., B.Sc., A.R.I.C., Chairman of the South Wales Section of the Royal Institute of Chemistry, introduced the President of the Society, Mr. R. C. Chirnside, F.R.I.C., who took the Chair at the meeting. The subject was "Rock and Mineral Analysis and Geochemical Prospecting," and the following papers were presented and discussed: "Modern Methods of Silicate Rock Analysis," by R. A. Chalmers, B.Sc., Ph.D., "Modern Trends in Geochemical Analysis," by E. A. Vincent, M.A., B.Sc., Ph.D., F.R.I.C., and "Geochemical Prospecting," by J. S. Webb, Ph.D., A.R.S.M., M.I.M.M. (see summaries below).

## MODERN METHODS OF SILICATE ROCK ANALYSIS

DR. R. A. CHALMERS said that the classical methods of rock analysis were adequate for their purpose but were tedious to use if many analyses were required, and liable to give false results unless applied by an expert. An increase in speed could be achieved by operating on the semi-micro or micro scale, but more care and attention to detail would be required. Of recent years, development of methods had followed two main paths. One was the designing of new methods within the framework of the old scheme, and the other the use of spectrophotometric methods as far as possible.

Most attention had been paid to the second line of attack, as was witnessed by the many schemes of "rapid" analysis that had been suggested. The rapidity lay in the relatively large numbers of samples that could be handled simultaneously, rather than in the time taken for a single analysis. Objections had been made to these schemes on the score that they were not sufficiently flexible to accommodate successfully the wide range of silicate materials that was met in practice. Another criticism was that the methods used had simply been compiled from existing sources without adequate investigation of applicability in the new context, and that they had seldom been specially designed for the job. There was much to be said for the use of a new approach to the problem of silicate analysis, but any new scheme suggested had to be rigorously tested to ensure its freedom from interferences, systematic errors and so on.

Comparative tests between various methods for the determination of the same constituent, silica for example, indicated that the most severe problem was that of decomposing the sample properly. It was no use having a method that was excellent when applied to one particular ionic species, if it was not possible to guarantee that the whole of the constituent sought would be present in the correct form. Some improvement had been effected by the use of sinter techniques with sodium peroxide, sodium carbonate, or sodamide, but more work was needed.

When the methods themselves were considered, an obvious approach was to prepare a solution of known volume from a macro sample and then to use small aliquots for analysis by microchemical methods. Hand-plotted spectrophotometric titration curves permitted the accurate determination of lime and magnesia by EDTA titration; the flame photometer was invaluable for alkali-metal determinations; iron could be done volumetrically, and so might aluminium after a solvent extraction of interfering elements, such as iron and titanium. For the minor constituents, such as manganese and phosphorus, spectrophotometric methods had always been advocated. Silica might be done on a separate sample by a differential spectrophotometric method; water should be determined by a high-temperature ignition method.

For the future, the requirements were better methods of decomposition and simple direct methods of determination applicable to a wide range of types of sample.

## MODERN TRENDS IN GEOCHEMICAL ANALYSIS

DR. E. A. VINCENT said that careful analysis of pure samples of the constituent minerals isolated from a suite of related rocks would often yield information of greater geological and geochemical significance than analyses of the rocks themselves. The petrologist needed analyses for the common major elements to establish unequivocally the positions of his minerals in series where extensive isomorphous substitution occurred; the specialised mineralogist might require accurate analyses involving almost any element in order to establish the constitution of a newly discovered or rare mineral; the interest of the geochemist tended to be directed more towards the minor and trace elements, particularly from a crystal-chemical standpoint.

Pure samples of individual minerals weighing from 10 to 100 mg could usually be physically separated from their parent rocks, although samples weighing a gram or so might prove impossible to obtain, as the grain size of the minerals in a rock was often as small as 0.1 mm, or less. Most exact mineral analysis had therefore to be done on the semi-micro or micro scale. Rapid methods, leaning heavily on spectrophotometry, were replacing classical separation procedures in silicate rock analysis, and good progress had been made in refining such methods so that they would be suitable for accurate mineral analysis involving the commoner elements. Much good work had been done in the past by using gravimetric and volumetric methods and these continued to have their place in

the analysis of minerals of more unusual elements, or where certain commoner elements were present in unusual proportions.

The amplitude of the variations in concentration of a trace element as a result of a geological process was frequently very much greater than that of the major element it accompanied, and the wide application of optical-emission spectrography had enabled the broad distribution patterns of a wide range of elements to be worked out. Inevitably, as the science progressed, some geochemical problems arose for which spectrochemical analysis was insufficiently sensitive or insufficiently precise and accurate. In some such instances neutron-activation analysis or isotope-dilution analysis might profitably be applied. The sensitivity of the neutron-activation method had permitted the effective study of the geochemical behaviour of some elements that were beyond the reach of optical spectrography, at least without some pre-concentration stage. Examples were the distribution of indium (0.003 to 0.3 p.p.m.) and gold (0.001 to 0.003 p.p.m.) between co-existing silicate and oxide minerals in igneous rocks. The inherent accuracy and precision of both neutron-activation and isotope-dilution analysis was higher than in optical spectrography, and matrix effects were generally less troublesome. Neutron-activation methods for the determination of a fairly wide range of elements in complex geological materials were now available, but the analyses could not compare with the spectrographic in speed, were relatively expensive and were not applicable in all geochemical laboratories. Standard samples analysed by neutron activation were invaluable for calibrating optical spectrography and other trace-analysis methods.

Isotope-dilution analysis by means of the mass spectrometer had great possibilities, and high precision was attainable even at low concentrations. In geological laboratories its chief application so far had been to the determination of uranium, thorium, rubidium, strontium, argon and occasionally potassium, in connection with geological age measurement by the uranium - lead, thorium - lead, potassium - argon and rubidium - strontium methods. Rubidium and strontium could be determined with a precision of 2 per cent. or better at or below the part-per-million level.

The possibilities of X-ray fluorescence spectrography in geochemical analysis were only now being actively explored; this precise, non-destructive method might soon do for many trace elements what the rapid spectrophotometric methods had done for common major elements. A particularly interesting development was the application of a modified version of Castaing and Guinier's electron probe to determine quantitatively the distribution of elements in single grains showing compositional zoning or consisting of two or more minerals intergrown on a minute scale.

#### GEOCHEMICAL PROSPECTING

DR. JOHN S. WEBB said that geochemical methods of mineral exploration were based on the premise that diagnostic disturbances in the normal distribution pattern of chemical elements could exist in accessible material in the vicinity of concealed ore deposits. Such disturbances, or geochemical anomalies, resulted from the natural dispersion of elements from the site of the parent deposit and were commonly sought by the systematic sampling and analysis of rock, soil, vegetation, stream water and stream alluvium.

Geochemical dispersion patterns were subdivided into two genetic categories, namely, *primary dispersions* formed in depth at the time of mineralisation, and *secondary dispersions*, which were usually formed near the surface in the zone of weathering.

Primary dispersion patterns could occur as (a) regional variations in the trace-element content of rocks and minerals associated with metallogenetic provinces, (b) aureoles of impregnation in the wall-rocks surrounding individual deposits, or (c) "leakage" dispersions of trace metals in the channel-ways followed by mineralising solutions. In all cases, the primary dispersion was an integral part of the ore-forming processes. The interpretation of the geochemical anomalies in terms of the location of possible associated deposits was often difficult and was always dependent on the complexity and understanding of the local geology.

Secondary dispersions, on the other hand, were usually an integral part of the weathering cycle, and although the dispersion processes were again complex, considerable progress had been made in the development and application of techniques having a proved practical value in prospecting. This was particularly true of geochemical soil



surveys in areas of residual overburden, where the methods had been successfully used for detecting the presence of sub-outcropping deposits of base metals, copper, nickel, arsenic-gold, antimony, chromium, tin, tungsten, molybdenum and others.

At times, positive results had been obtained where copper, lead and zinc mineralisations had been concealed by transported glacial cover up to some tens of feet thick. Here, the metals had had the opportunity of migrating upwards into the overlying material by diffusion and other processes, including the growth of vegetation that has extracted the ore metals as part of its nutrient uptake. Although the systematic analysis of the plants themselves had been employed on occasions, it was normally found more practicable to sample the underlying soil wherein metal had accumulated over generations in the biogeochemical cycle.

While analysis of vegetation (biogeochemical prospecting) might be limited in its application, the systematic observations of plant assemblages and the distribution of diagnostic species indicative of the presence of abnormal metal concentrations in the soil (geobotanical prospecting) offered much more attractive possibilities, which had not yet been fully explored.

Whereas geochemical soil and vegetation anomalies were usually restricted to the immediate vicinity of the parent mineral deposit, abnormal concentrations of metal might sometimes be detected in the surface-drainage system up to several miles downstream from mineralisation. Where these geochemical dispersion "trains" could be shown to exist, the systematic sampling of stream water or alluvium might constitute a useful aid in the rapid mineral reconnaissance of comparatively large areas.

Sampling and analysis of stream alluvium for cold extractable (readily soluble) metal had given particularly encouraging results in reconnaissance for copper and base-metal deposits.

The practical application of geochemical methods had been made possible only by the development of extremely rapid simple tests, and there were available trace-analytical techniques for a wide range of metals capable of being performed with adequate accuracy by semi-skilled personnel. For the most part, these tests were simplified versions of classical colorimetric and chromatographic methods, although spectrographic, fluorimetric and other procedures might be utilised for particular problems.

Current research was active and aimed at (a) broadening the scope of existing methods, (b) extending knowledge of dispersion processes and the controlling factors leading, it was hoped, to improved techniques and interpretation, and (c) investigating the regional approach to comprehensive geochemical reconnaissance and developing appropriate analytical techniques. Although much research and development undoubtedly remained to be done, the progress made and the practical results obtained in actual prospecting to date ensured that geochemical methods, used in conjunction with geological, geophysical and other sources of information, would have an increasingly greater part to play in modern mineral exploration.

#### MIDLANDS SECTION

An Ordinary Meeting of the Section was held at 6.30 p.m. on Thursday, May 28th, 1959, in Room 301, Luton and South Bedfordshire College of Further Education, Park Square, Luton. The Chair was taken by the Chairman of the Section, Dr. S. H. Jenkins, F.R.I.C., F.Inst.S.P.

The following paper was presented and discussed: "The Analysis of Silicones and Related Organo-Silicon Compounds," by J. C. B. Smith.

#### PHYSICAL METHODS GROUP

A DEMONSTRATION Meeting of the Group at which laboratory-made apparatus was shown was held in the Physical Chemistry Laboratory of the Brunel College of Technology, Acton, at 6.30 p.m. on Tuesday, April 28th, 1959.

The following pieces of apparatus were demonstrated—

Constant-head unit without overflow—A. E. Horton (National Coal Board, W. Midlands Division).

This is constructed on the principle of the domestic water-cistern, with a table-tennis ball attached to Perspex pivots. The exit is fitted with interchangeable jets.

Constant-rate liquid-delivery pump—A. M. Freke (National Coal Board, W. Midlands Division).

A glass syringe leads to a chamber of which the inlet and outlet tubes are fitted with slitted rubber teats that act as one-way valves. The syringe can be operated by either crank or cam mechanism.

Colony counter—K. A. Allen (Distillers Company Ltd.).

Petri dishes are placed on a spring-loaded circular platform. The pressure used to mark each colony actuates an automatic counter.

Semi-micro Karl Fischer moisture-determination apparatus—R. J. Motz (Mars Ltd.).

A spring-loaded agitator block rotates the bottom of the reaction vessel; the top is sealed by a spherical joint lubricated with oil. Platinum electrodes fused into the sides of the reaction vessel are connected to a "Magic Eye" indicator by detachable springs. (Constructed by D. A. E. Crouch.)

Unit apparatus for the teaching of physical methods of analysis—A. L. Glenn (School of Pharmacy, London University).

A set of basic units, in Perspex boxes, can be assembled in different ways to construct potentiometers, pH meter, polarograph, absorptiometer and photo-electric spectrophotometer. (Constructed by P. C. Barden and B. J. Hill.)

Device for plotting the quotient of two curves—A. L. Glenn (School of Pharmacy, London University).

A simple and rapid method of obtaining a quotient curve with the Honeywell-Brown Recorder. It is applicable to single-beam infra-red spectrometry. It can easily be modified to give a difference curve. (Constructed by P. C. Barden and B. J. Hill.)

Stillhead—K.A. Williams.

A hole of approximately the diameter of the tube in the side of the rising part of the stillhead and just above a constriction at its lower end eliminates undesirable splashing during distillation.

Battery-charging system for the Unicam SP500 spectrophotometer—A. T. S. Babb (J. Lyons & Co. Ltd.).

This has been described in *Spectrovision* (Unicam Instruments Ltd.), No. 6, 1958, p. 9.

Motor-driven syringes—D. O. Singleton (Beecham Maclean Ltd.).

(a) *For continuous operation*—A constant-speed motor unscrews a threaded bar from a brass cylinder. The cylinder is free to move horizontally in a self-oiling bearing and is fitted with a ball end that transfers the thrust normally to the plunger of a syringe. The device is combined with a pH meter and recorder to evaluate antacids.

(b) *For intermittent operation*—A constant-speed motor turns a circular plate. Trips on the plate actuate a system of levers and counterweights operating an automatic pipetting syringe. (Constructed by L. D. Parke.)

A small de-mountable sample press and holder for the radiochemical assay of powders—A. E. Bird (Beecham Research Laboratories Ltd.).

The press facilitates the preparation of uniform pellets from powders so that a fixed area is presented to the counter. The pellets can be counted *in situ* and then removed for weighing. (Designed by H. D. C. Rapson and constructed by R. Peters.)

A single-stroke electromagnetic vapour pump for circulation of gases through absorption columns—A. E. Bird (Beecham Research Laboratories Ltd.).

The pump has replaceable valve flaps and a simple actuating mechanism, and will circulate effectively against a pressure of 5 mm of mercury. (Designed by H. D. C. Rapson and constructed by A. Matthes.)

Electrical micro-balance—P. G. Marshall (Boots Pure Drug Co. Ltd.).

A current is passed through two meters connected in series. The movement of one is suitably mounted for use as a torsion balance. The other indicates the current, which can be adjusted to counterbalance the weight of the sample on the torsion balance. The indicating meter is calibrated to read directly in milligrams.

Electrode holder and spectrographic timer—W. H. Harper and L. R. Hall (Boots Drug Co. Ltd.).

Electric pulses are obtained every second from contacts operated by a synchronous motor and operate standard Uniselectors that can be pre-set to operate a relay after a required interval. Three intervals can be timed consecutively, and the duration of the intervals is selected by switches.

**Molecular-distillation apparatus for isolating and identifying alkyl phthalate plasticisers in PVC film—C. J. Barker (Brunel College of Technology).**

The still consists of two aluminium blocks, one acting as heater and the other as condenser. Isolated phthalates are subsequently identified by ultra-violet spectroscopy and gas-liquid chromatography.

The following exhibits were demonstrated by A. J. Maisey (British Nylon Spinners, Ltd.)—  
A simple gas generator.

The Kipp principle is modified by covering the solid with carbon tetrachloride. A layer of acid rests above this and gas is generated by tilting the apparatus. The gas is washed by passing it through an internally fitted bubbler.

**Apparatus for effecting fusion or wet combustion of organic matter without loss of volatile trace products.**

A distillation system is sealed by a series of bubbler traps. By means of a special three-way stopcock the apparatus can be emptied automatically without being dismantled.

**An electrical heating range for micro-Kjeldahl digestions.**

A bar from a domestic electric fire acts as heat source.

**A simple device for detecting inorganic borates.**

The sample is mixed with methanol and sulphuric acid in a narrow tube drawn to a jet. Heating in a boiling-water bath and igniting the issuing vapours results in a steady green flame if borate is present.

The following exhibits from British Oxygen Research and Development Ltd., were demonstrated by J. Armond, J. H. Glover and G. Gouldstone—

**Catalytic ozone analyser.**

The mixture of ozone with carrier gas is passed through a bed of catalyst (Hopcalite) where the ozone is decomposed to oxygen. The heat of decomposition raises the temperature of the gas and this is detected by five copper - constantan thermocouples in series connected to a moving-coil meter to give a measure of the ozone concentration. It is suitable for use in the range 0 to 5 per cent. of ozone.

**Colorimetric ozone analyser.**

This makes use of the absorption of visible light by ozone in the waveband 5600 to 5200 Å. The test gas flows through a glass cell 48 inches long. A selected waveband from the transmitted light falls on a photovoltaic cell, the output of which is compared with that of one illuminated by the same light source through a similar absorption tube containing air. It is suitable for the range 0 to 5 per cent. of ozone.

**Analyser for ortho and para hydrogen.**

This makes use of four thermal-conductivity cells in a Wheatstone bridge network to compare the gas under test with 25 per cent. para hydrogen. A platinum spiral at 6000° C produces 25 per cent. para hydrogen from the inlet gas.

**Anaesthetic gases analyser.**

This incorporates a thermal-conductivity detector and a novel sampling device. It analyses trilene - oxygen or ether - oxygen mixtures.

**Interrupted oxygen analyser.**

This measures the fall in potential due to reduction of oxygen at the surface of a platinum micro-electrode.

**Micro carbon and hydrogen apparatus.**

A standardised train incorporates a simple gas-volume meter to indicate the amount of oxygen used in each determination.

The following exhibits from the Chemical Inspectorate, Ministry of Supply, were demonstrated by R. F. Branch, E. G. N. Marsden, G. F. Reynolds and J. White—

**Rotary separating-funnel holder (photograph).**

**Titration apparatus (photograph).**

**Capstan for adjusting mercury levels of a Lunge nitrometer.**

A screw-head and threaded bar provide a fine levelling adjustment suitable for any manometric system. The clamp may also be adjusted manually.

แผนกห้องสมุด กรมวิทยาศาสตร์

กระทรวงอุตสาหกรรม

Inverted microscope for examining residues on the bottom of a transparent vessel containing liquid.

An inclinable Winchester-bottle holder for dispensing acids and inflammable liquids at bench level.

The bottle is placed in an inclinable cradle and fitted with a polythene stopper carrying a short delivery tube.

Cutter for making porous-cup electrodes for use with spectrographic solution technique.

This incorporates cutter, drill, adjustable locking screw and a dust-extraction assembly that can be attached to a household vacuum cleaner.

A machine for the wet sieving of powders.

This enables powders to be sieved through a single rotating sieve with a controlled flow of water.

Slide rule for use with the Rigden apparatus on the rapid routine determination of the specific surface of powders.

A safety shield and device for the compacting of explosive powders in surface-area determinations.

A distributor tube for liquid - liquid extractors.

This enables lighter-than-water solvents to pass up through an aqueous solution as a fine spray of solvent bubbles.

An adjustable wedge cell for infra-red spectrometry.

The wedge cell is clamped in a special carriage, which a fine screw moves along guides on a mount.

A liquid - solid extractor for sparingly soluble materials.

The sample is introduced into a steam-heated chamber that is fed with a continuous supply of fresh solvent from a condensing system and return tube.

An "uphill" siphon.

This utilises a gravity feed and vacuum line to circulate liquid from a thermostat-controlled bath through an instrument or piece of apparatus and back to the bath.

A simple limiting valve for a vacuum system.

This acts as a pressure regulator or as a safety precaution against implosion of glass apparatus. It is governed by a weight, a tapered glass pin and a cheesehead screw acting as piston.

#### BIOLOGICAL METHODS GROUP

DURING the evening of Tuesday, May 5th, 1959, a party of 20 members of the Group toured the Anchor Brewhouse of Courage and Barclay, Ltd., Horselydown, London, S.E.1, by kind permission of the Brewers.

The party was subsequently entertained at the "Anchor Tap," where, in the absence of the Chairman, the thanks of the members were suitably accorded by the Honorary Secretary of the Group, Mr. K. L. Smith, M.P.S.

## A Modified Hydroxamic Acid Method for Determining Total Esterified Fatty Acids in Plasma\*

BY D. M. MORGAN AND K. J. KINGSBURY

(Surgical Unit, St. Mary's Hospital, London, W.2)

A colorimetric procedure is described for the determination of esterified fatty acids in plasma. The method is based on the formation of hydroxamic acids, which react with ferric chloride to form a coloured complex having an absorption maximum at  $515\text{ m}\mu$ . Twenty replicate determinations had a coefficient of variation of  $\pm 0.85$  per cent., and recoveries of 99.7 per cent. were obtained with glyceryl trioleate. The method, which has been in use for over 4 years, has few manipulative steps, requires no special apparatus and permits a large number of determinations to be performed by one person.

The normal range of esterified fatty acids in 106 samples of normal human fasting plasma was found to be 5.94 to 18.9 (mean 11.58) milliequivalents per litre.

In the course of work on lipid metabolism, it became necessary to determine the total esterified fatty acids in plasma. The determination had to be carried out on an ethanol - diethyl ether extract of plasma, as this would permit several different determinations to be made on a single extract and need few manipulations, so that a large number of samples could be dealt with by one person in a reasonable time.

It appeared that a method based on the spot test for esters of carboxylic acids, devised by Feigl, Anger and Frehden,<sup>1</sup> would fulfil these requirements. The chemistry of the reaction, first reported by Lossen,<sup>2</sup> has been said by Feigl<sup>3</sup> to be in accordance with the following equation—

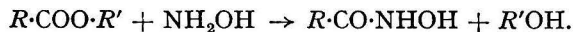

The hydroxamic acid so formed is coupled with trivalent iron to form a highly coloured chelate complex in accordance with the following equation—

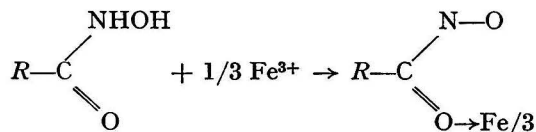

Hill<sup>4,5</sup> was the first to publish a quantitative method for fatty acid esters based on this reaction, although it had been developed earlier by Lipmann and Tuttle<sup>6</sup> for the determination of acyl phosphates in enzyme systems. Thompson<sup>7</sup> used Hill's method to determine volatile esters, and Bauer and Hirsch<sup>8</sup> modified it to determine fatty acid esters in serum and specified the use of strictly anhydrous conditions, as, they said, the presence of water interferes with the formation of hydroxamic acids; a similar method was developed by Hack.<sup>9</sup> In both these techniques, the extract is evaporated to dryness and subsequently heated to form the hydroxamates, a procedure that also occurs in the methods of Jarrer and Polonovski,<sup>10</sup> Nailor, Bauer and Hirsch<sup>11</sup> and Goddu, LeBlanc and Wright,<sup>12</sup> although the last-named workers point out that hydroxamic acids are destroyed at high temperatures.

Details have been published of other methods in which the hydroxamic acids were formed in aqueous media—that of Lipmann and Tuttle has already been mentioned. These workers later modified their method to determine hydroxamates formed from long-chain fatty acids, the final concentration of ethanol in the coloured solution being 50 per cent.<sup>13</sup> Hestrin<sup>14</sup> determined acetylcholine with aqueous reagents, and a combination of Hill's method with that of Lipmann and Tuttle was used by Kornberg and Pricer<sup>15</sup> to determine separately the water-soluble and water-insoluble hydroxamic acid derivatives formed by enzymatic breakdown of long-chain fatty acids.

\* Presented at the meeting of the Society on Wednesday, April 1st, 1959.

Stern and Shapiro's method<sup>16</sup> for esterified fatty acids in blood appears to be based on Hestrin's method, but these workers reported that plasmas having a high cholesterol level caused a turbidity in the final coloured solution, although this turbidity could be cleared by the addition of ether. Finally, Gey and Schon<sup>17</sup> carried out the formation of hydroxamic acids from plasma fatty acids in a glycine - sodium hydroxide buffer (as used by Weissman and Meyer<sup>18</sup> in the determination of lactones), but found that the reaction took at least 7 hours to go to completion. The method described here has been used in this laboratory for 4 years, during which time well over five thousand determinations have been carried out. No heating stages are involved, the operations are few and the turbidity reported by Stern and Shapiro is overcome.

#### METHOD

##### REAGENTS—

*Absolute ethanol, aldehyde-free*—If blank solutions have optical densities greater than 0.07, purify the ethanol by heating under reflux with, and distilling from, a solution containing 5 g each of potassium permanganate and sodium hydroxide per litre.

*Diethyl ether, peroxide-free*—Analytical-reagent grade ether is usually satisfactory if stored in the dark and kept tightly stoppered.

*Ethanol - diethyl ether mixture (Bloor's solvent)*—Mix 3 volumes of ethanol and 1 volume of diethyl ether. Store the mixture in a dark bottle.

*Hydroxylamine solution, 3.5 per cent.*—Dissolve 3.5 g of hydroxylamine hydrochloride,  $\text{NH}_2\text{OH}\cdot\text{HCl}$ , in 30 ml of distilled water, and make up to 100 ml with ethanol. Store the solution in a refrigerator.

*Sodium hydroxide solution, 6 per cent.*—Dissolve 6 g of sodium hydroxide in 100 ml of 50 per cent. ethanol.

*Hydrochloric acid, 25 per cent.*—Dilute 25 ml of hydrochloric acid, sp. gr. 1.18, to 100 ml with 50 per cent. ethanol.

*Ferric chloride solution*—Dissolve 6 g of ferric chloride,  $\text{FeCl}_3\cdot 6\text{H}_2\text{O}$ , in 10 ml of *N* hydrochloric acid, add 10 ml of distilled water, and dilute to 100 ml with ethanol.

*Standard fatty acid ester solution*—Dissolve 1 milli-equivalent of the chosen fatty acid ester (see p. 412) in 100 ml of ethanol - diethyl ether mixture. Dilute 10 ml of this solution to 100 ml with ethanol - ether mixture to prepare the working standard solution, 1 ml of which contains 0.001 milli-equivalent of esterified fatty acid.

##### PROCEDURE—

Place about 8 ml of ethanol - ether mixture in a 200-mm  $\times$  25-mm test-tube having a calibration mark at 10 ml. Add 0.5 ml of plasma with continuous agitation of the test-tube to produce a finely divided precipitate. Bring the contents of the test-tube to the boiling-point in a water bath, cool, make up to 10 ml, and filter through a fat-free Whatman No. 43 filter-paper. Measure 4 ml of the filtrate into a 150-mm  $\times$  25-mm test-tube, and add 1 ml each of 3.5 per cent. hydroxylamine solution and 6 per cent. sodium hydroxide solution. Close the test-tube with a rubber stopper, agitate to mix the contents, and set aside for 30 minutes. Add 1 ml of hydrochloric acid, shake, and add 1 ml of ferric chloride solution. Replace the stopper, shake, set aside for 30 minutes to allow colour to develop, and measure the colour intensity at 515  $\mu$ . Take care to prevent the contents from coming into contact with the rubber stopper when the test-tube is shaken. When grossly lipaemic plasmas are analysed, use 1 or 2 ml of extract diluted to 4 ml with ethanol - ether mixture, and amend the calculation accordingly.

##### PREPARATION OF CALIBRATION GRAPH—

Place 1, 2, 3 and 4-ml portions (0.001 to 0.004 milli-equivalent of ester) of the working standard solution in 150-mm  $\times$  25-mm test-tubes, make up to 4 ml with ethanol - ether mixture, and carry out the procedure described above. Fig. 1 shows a typical calibration graph, which is linear over the range 0.0 to 0.005 milli-equivalent of ester; this corresponds to 0 to 700 mg of esterified fatty acid per 100 ml of plasma. Two standards containing 0.002 and 0.004 milli-equivalent of ester are analysed with each series of determinations.

## CALCULATION OF RESULTS

The results can either be determined from a calibration graph or, since this is linear, calculated from the following expression—

$$\frac{\text{Optical density of test solution}}{\text{Optical density of standard solution}} \times \frac{2}{1000} \times \frac{1}{0.2} \times 1000,$$

when the standard solution containing 0.002 milli-equivalent of ester has been used and 0.2 ml of plasma, *i.e.*, 4 ml of extract, was taken; this gives the result as milli-equivalents of esterified fatty acids per litre of plasma. If the result is required as milligrams of esterified fatty acids per 100 ml of plasma, the expression becomes—

$$\frac{\text{Optical density of test solution}}{\text{Optical density of standard solution}} \times \frac{2}{1000} \times \frac{1}{0.2} \times 100 \times 275$$

if the average molecular weight of the plasma fatty acids is taken as being 275 (see p. 413).

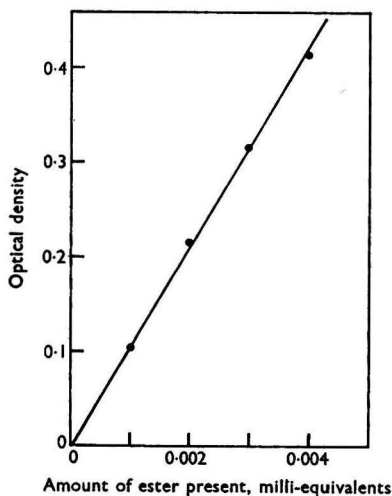

Fig. 1. Typical calibration graph for glyceryl trioleate

## DISCUSSION OF THE METHOD

When Stern and Shapiro's method<sup>16</sup> was tried, we confirmed the turbidity they reported and its removal by the addition of ether. However, this was unsatisfactory because of the difficulty of accurately adding small amounts of ether by pipette. Attempts were therefore made to remove the turbidity by adding less-volatile solvents, and butanol, propanol, ethyl methyl ketone, 2-methoxyethanol (methyl Cellosolve), benzene, chloroform, isopropyl ether and di-*n*-butyl ether were tried, but were found to be unsuccessful. When the concentration of ethanol in the final solution was increased from 60 per cent., as used by Stern and Shapiro, to 80 per cent., there was some improvement, but higher concentrations resulted in the precipitation of other reagents. However, it was found that if, under the conditions described in this paper, the time allowed for the formation of the hydroxamic acids was increased to a minimum of 30 minutes, no turbidity occurred when plasmas having cholesterol levels in excess of 500 mg per 100 ml or solutions of cholesteryl acetate were analysed.

The colour produced in the proposed method is completely stable for 90 minutes and decreases by 10 per cent. in 16 hours. If necessary, the test-tubes can be left overnight between the addition of alkali and hydroxylamine and the development of the final colour, as experiments have shown that solutions treated in this way can be kept up to 48 hours without effect on the intensity of the final colour.

Compounds that react with hydroxylamine to form hydroxamic acids include lactones, carboxylic anhydrides, polyesters of polycarboxylic acids, esters of simple carboxylic acids and some esters of cyclic carboxylic acids.<sup>14</sup> Acetic acid has been shown to react directly with

ferric chloride solution to form a coloured complex<sup>12</sup>; however, investigation has shown that this reaction is reversed by the presence of excess of strong acid, and, since in the proposed procedure hydrochloric acid is added to the test solutions before ferric chloride, no interference from free acetic acid occurs. Cholesterol, urea, amino acids and sugars do not form hydroxamic acids, nor do glycerophosphates.<sup>16</sup> Hack<sup>9</sup> gives an extensive list of esters that react quantitatively to form hydroxamic acids, and this includes most of those likely to be encountered in plasma. Citrates and oxalates interfere with the reaction, as do tartrates, but only when their concentration in the final solution exceeds 30 mg. As the use of citrated or oxalated plasma introduces only 5 mg of these salts at the most, their effect is negligible. Interference is also caused by salicylates in plasma when their concentration exceeds that produced by a dose of 10 g per day.<sup>8</sup>

The absorption curves of the ethyl esters of fatty acids of various chain lengths are shown in Fig. 2. As can be seen, the chain length does not affect the wavelength at which maximum absorption occurs, nor does it affect the molar extinction of the esters, since all the peaks occur at the same wavelength and are of approximately the same height. Fig. 3 shows that the nature of the substance with which the acid is esterified also has no effect on the molar extinction or the wavelength at which this occurs.

Different workers have used a variety of esters as standards, *e.g.*, triacetin, tributyrin, tricapyrylin and triolein,<sup>16</sup> trilaurin and tristearin,<sup>17</sup> tripalmitin,<sup>8</sup> methyl oleate,<sup>8,11</sup> cholesteryl oleate<sup>11</sup> and methyl stearate.<sup>10</sup> The use of short-chain esters as standards should, however, be avoided, as it has been shown that these compounds react with hydroxylamine more rapidly than do the esters of long-chain fatty acids.<sup>12</sup> In the work reported here, pure glyceryl trioleate was used as standard.

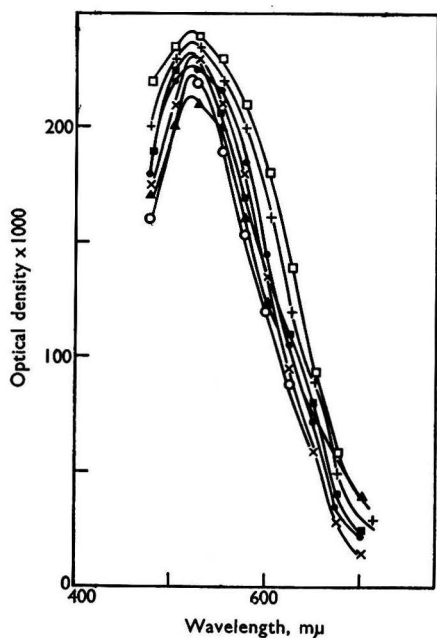

Fig. 2. Absorption curves for ethyl esters of fatty acids of different chain lengths. Concentration of esters,  $2.5 \times 10^{-4} M$ : □, oleate; ●, stearate; ○, palmitate; +, laurate; ×, octanoate; ▲, butyrate; ■, acetate

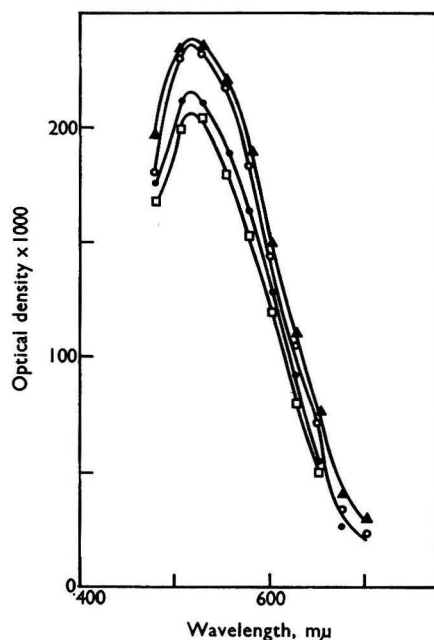

Fig. 3. Absorption curves for various acetates. Concentration of esters,  $2.5 \times 10^{-4} M$ : ●, methyl acetate; ▲, ethyl acetate; ○, glyceryl acetate; □, cholesteryl acetate

The absorption spectra of the standard and a plasma extract are shown in Fig. 4; each curve has a maximum at 515  $m\mu$ . Twenty replicate determinations on a single plasma gave a mean value of 411 mg of esterified fatty acids per 100 ml, and a standard deviation of 3.49 mg



(coefficient of variation  $\pm 0.85$  per cent.). The smallest amount of fatty acid ester that can be determined by the proposed method is 0.0001 milli-equivalent (0.03 mg) in a final volume of 8 ml, optical densities being measured in 1-cm cuvettes.

Those workers reporting recovery experiments have based their recoveries either on the addition of ethereal solutions of known amounts of esters to the ethanol-ether extract of a plasma<sup>11</sup> or on the analysis of mixtures of standard solutions and comparison of the results with those found for the pure solutions.<sup>9</sup> However, these experiments gave no indication of the percentage recovery of the esters from plasma, on which the accuracy of the method must be based. The recoveries reported here were from homogeneous mixtures of plasma and pure glycerides, which gave the esters most opportunity of being attached to lipoproteins, as in their natural state, and resulted in a mean recovery, for five separate determinations, of 99.7 per cent. The mixtures were prepared by shaking together known amounts of pure glyceryl trioleate and a previously analysed fasting plasma until a homogeneous mixture was obtained that did not separate when set aside for 10 minutes.

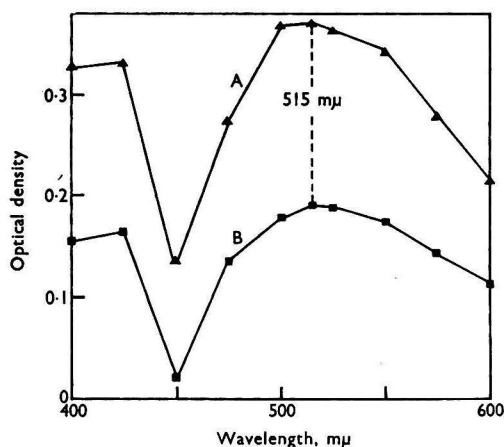

Fig. 4. Absorption spectra of coloured complexes: curve A, from glyceryl trioleate; curve B, from plasma

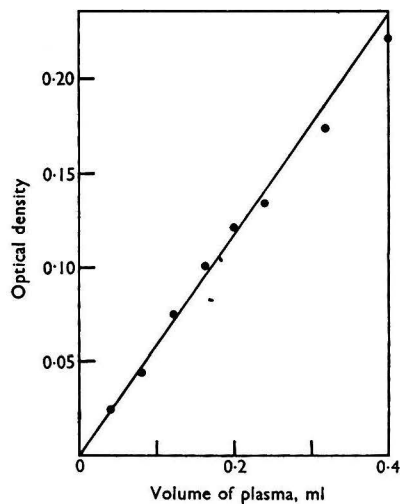

Fig. 5. Relationship between amount of fatty acid ester found, as optical density, and volume of plasma

Also, when the optical densities of the coloured solutions obtained by determining increasing amounts of a single plasma were plotted against the volume of plasma taken for each analysis, the result was a straight line (see Fig. 5). A further check on the accuracy of the method was obtained by analysing a known solution of cholesteryl acetate, and this gave the theoretical result when determined as cholesterol or as an ester.

When the results were expressed as milligrams of esterified fatty acids per 100 ml of plasma, it was assumed that equal amounts of oleic, palmitic and stearic acids were present, and the average molecular weight was therefore 275.

Analyses of plasma taken from 106 normal male subjects, all of whom had fasted for 16 hours before blood samples were taken, gave a range of 5.94 to 18.9 (mean 11.6) milli-equivalents of esterified fatty acids per litre. This is similar to the range of 7.0 to 12.6 (mean 9.2) milli-equivalents per litre for 102 subjects reported by Bauer and Hirsch<sup>8</sup> and to that of 8.6 to 20.8 (mean 12.3) milli-equivalents per litre for 42 subjects reported by Nailor, Bauer and Hirsch.<sup>11</sup>

#### REFERENCES

1. Feigl, F., Anger, V., and Frehden, O., *Mikrochemie*, 1934, 15, 9.
2. Lossen, H., *Annalen*, 1869, 150, 314.
3. Feigl, F., "Spot Tests," Fourth Edition, Elsevier Publishing Co. Ltd., Amsterdam and New York, 1954, Volume II, p. 170.

4. Hill, U. T., *Ind. Eng. Chem., Anal. Ed.*, 1946, **18**, 317.
5. ———, *Anal. Chem.*, 1947, **19**, 932.
6. Lipmann, F., and Tuttle, L. C., *J. Biol. Chem.*, 1945, **159**, 21.
7. Thompson, A. R., *Austral. J. Sci. Res.*, 1950, **3**, 125.
8. Bauer, F. C., and Hirsch, E. F., *Arch. Biochem.*, 1949, **20**, 242.
9. Hack, M. H., *Arch. Biochem. Biophys.*, 1955, **58**, 19.
10. Jarrer, M., and Polonovski, J., *Bull. Soc. Chim. Biol.*, 1955, **37**, 495.
11. Nailor, R., Bauer, F. C., and Hirsch, E. F., *Arch. Biochem.*, 1955, **54**, 201.
12. Goddu, R. F., LeBlanc, N. F., and Wright, C. M., *Anal. Chem.*, 1955, **27**, 1251.
13. Lipmann, F., and Tuttle, L. C., *Biochim. Biophys. Acta*, 1950, **4**, 301.
14. Hestrin, S., *J. Biol. Chem.*, 1949, **180**, 249.
15. Kornberg, A., and Pricer, W. E., *Ibid.*, 1953, **204**, 329.
16. Stern, I., and Shapiro, B., *J. Clin. Path.*, 1953, **6**, 158.
17. Gey, K. F., and Schon, H., *Hoppe-Seyl. Z.*, 1956, **305**, 149.
18. Weissman, B., and Meyer, K., *J. Amer. Chem. Soc.*, 1954, **76**, 1753.

Received November 12th, 1958

#### DISCUSSION

MR. C. WHALLEY asked the authors if they had carried out the method with esters of conjugated acids. He had tried out a similar method for the analysis of drying oils and had experienced difficulties, obtaining low results. He had traced these low results to the conjugated esters. Admittedly, his procedure was slightly different from the authors' in that he used ferric perchlorate, but he wondered if the authors had any evidence that the nature of the acid had any effect on the reaction.

MR. MORGAN replied that they had been unable to obtain sufficiently pure samples of esters of conjugated fatty acids to enable them to construct reliable calibration curves. However, results obtained with tung oil (which contained about 80 per cent. of eleostearic acid), although giving a linear graph when the amount of oil taken was plotted against the resulting optical density, were 15 to 20 per cent. less than the theoretical value.

## The Determination of Small Amounts of $\alpha$ -Picoline in Pyridine by a Solution-temperature Method\*

BY K. A. ADEY

(Midland Tar Distillers Ltd., Four Ashes, nr. Wolverhampton)

AND J. D. COX

(National Chemical Laboratory, Teddington, Middlesex)

Concentrations up to 2 per cent. w/w of  $\alpha$ -picoline in pyridine can be determined with an uncertainty of about  $\pm 0.1$  per cent. by measuring the lower solution temperature of a mixture containing the two bases, water and potassium chloride in specified proportions. On the assumption that the only impurities in "pure pyridine (99 per cent. minimum)," as defined by the British Standard for this grade, are  $\alpha$ -picoline and water, the pyridine content can be found by difference. The method is thus an alternative to that based on the clearing-temperature of a perchlorate solution, which has been adopted in the British Standard.

THE purest grade of pyridine commercially available is described in a Draft British Standard<sup>1</sup> as "pure pyridine (99 per cent. minimum)." The main impurities likely to be found in coal-tar pyridine of this grade are water and  $\alpha$ -picoline. Water can be readily determined by the Karl Fischer method, but there has been no satisfactory method for determining the  $\alpha$ -picoline. The method commonly used<sup>2</sup> for determining pyridine in admixture with other pyridine bases, even in the modified form proposed in the Draft British Standard,<sup>1</sup> is barely sensitive enough to determine the pyridine content within the limits required. Our purpose was to devise a more sensitive method for this determination. In the proposed method, the water and  $\alpha$ -picoline contents are separately determined and the pyridine content is found by difference. The method for determining  $\alpha$ -picoline involves measuring the lower solution temperature of a mixture of the pyridine sample with a potassium chloride solution and takes advantage of the markedly different solubilities of pyridine and  $\alpha$ -picoline in this solution.<sup>3</sup>

\* Presented at the meeting of the Society on Wednesday, April 1st, 1959.

The experimental work was divided into two parts. First, an attempt was made to find the optimum conditions for performing the analysis by varying the relative proportions of the components of the solutions. Lack of time precluded a study of the effect of salts other than potassium chloride. Secondly, the proposed method was tested for its suitability as a routine method; this study gave information about its expected repeatability and reproducibility (these terms have the significance previously ascribed to them<sup>4</sup>).

#### MEASUREMENT OF SOLUTION TEMPERATURE

##### REAGENTS—

Analytical-reagent grade potassium chloride was dried in an oven at 110° C (see Note). Solutions were made up with distilled water in NPL grade A calibrated flasks, care being taken to dilute to the mark at 20° C. The pyridine and  $\alpha$ -picoline used were standard samples prepared at the National Chemical Laboratory and certified as having purities of 99.91 and 99.85 mole per cent., respectively.

NOTE—Analytical-reagent grade potassium chloride that has been dried at 110° C may still contain a little water. It is extremely important, therefore, that any analyst using the proposed method and calibration figures should keep as close to our conditions as possible and, in particular, should dry his potassium chloride at 110° C for 4 hours.

##### PROCEDURE—

Solution temperatures were determined in the following way. Weighed amounts of pyridine and potassium chloride solution (total weight 0.3 to 0.5 g) were sealed inside small borosilicate-glass tubes. The tubes were held in a bracket that could be shaken mechanically and were lowered into a lagged oil-bath furnished with a stirrer and bare-wire immersion heater; they could be viewed against a diffusely lit background. The temperature of the oil-bath was measured by means of an NPL certified thermometer calibrated to 0.2° C and equipped with a magnifying eyepiece.

For measurement of a solution temperature, the temperature of the oil-bath was raised quickly to within 1° C of the expected solution temperature and was subsequently raised at a rate not exceeding 0.05° C per minute until the clear solution in the tube suddenly became cloudy. With some mixtures, light-scattering was observed before the solution temperature was attained, but the solution temperature could still be determined with about the same repeatability as for mixtures that did not exhibit light-scattering, *viz.*,  $\pm 0.05^\circ$  C.

##### RESULTS—

Experiments were carried out with (i) mixtures containing different proportions of pyridine base, (ii) mixtures made up with potassium chloride solutions of different concentrations, and (iii) mixtures made up from pyridine bases containing different small amounts of  $\alpha$ -picoline. The results are summarized in Tables I and II, wherein the temperatures have been corrected for thermometer calibration errors.

TABLE I  
SOLUTION TEMPERATURES OF PYRIDINE AND POTASSIUM CHLORIDE SOLUTION

Concentration of potassium chloride solution, % w/v	Concentration of pyridine in mixture, % w/w	Solution temperature, ° C
12.00	53.95	21.95
	51.53	27.65
	47.74	37.3
14.00	48.17	20.6
	38.65	42.1
	33.32	56.95
16.00	40.70	22.55
	34.52	35.35
	30.22	44.7
	25.57	55.0
20.00	20.78	70.35
	25.57	26.0
	24.92	27.1
	20.27	34.15
	25.00	27.03*

\* Determined by the proposed routine method.

TABLE II  
SOLUTION TEMPERATURES OF PYRIDINE -  $\alpha$ -PICOLINE MIXTURES AND POTASSIUM CHLORIDE SOLUTION

Concentration of potassium chloride solution, % w/v	Concentration of $\alpha$ -picoline in pyridine - $\alpha$ -picoline mixture, % w/w	Concentration of pyridine - $\alpha$ -picoline mixture in final mixture, % w/w	Solution temperature, °C
12.00	1.10	51.50	27.05
16.00	1.10	38.24	26.8
	1.10	33.07	37.75
20.00	0.95	25.39	25.6
	0.95	24.74	26.55
	0.95	19.39	34.9
	2.03	25.89	24.1
	2.03	20.03	32.9
	0.64	25.00	26.56*

\* Determined by the proposed routine method.

From calculations based on the results in Tables I and II, the following conclusions were drawn—

- (i) Within the range of compositions studied, the greatest sensitivity of the solution temperature to the concentration of  $\alpha$ -picoline in pyridine is given by 20 per cent. w/v potassium chloride solution.
- (ii) The least sensitivity of the solution temperature to the concentration of total pyridine base is also given by 20 per cent. w/v potassium chloride solution.
- (iii) The lowering of solution temperature caused by  $\alpha$ -picoline in pyridine is directly proportional to the  $\alpha$ -picoline content of the pyridine in the range 0 to 2 per cent. w/w of  $\alpha$ -picoline.
- (iv) The most convenient mixture for routine solution-temperature determinations consists of 25 per cent. w/w of pyridine base and 75 per cent. w/w of 20 per cent. w/v potassium chloride solution. The solution temperature is then 27.0° C when the base is pure pyridine and 26.3° C when the base is 1 per cent. w/w of  $\alpha$ -picoline plus 99 per cent. w/w of pyridine.

These conclusions were made the basis of a routine method for determining small amounts of  $\alpha$ -picoline in pyridine. This method involves use of the same apparatus as is employed in determining the clearing-points of pyridine-base perchlorates.<sup>5</sup>

#### ROUTINE METHOD FOR DETERMINING THE $\alpha$ -PICOLINE CONTENT OF PYRIDINE

##### PROCEDURE—

Weigh 200.00 g of analytical-reagent grade potassium chloride (dried at 110° C) into an NPL grade A calibrated flask, and make up to 1 litre with distilled water at 20° C. Assemble the apparatus described in "Standard Methods for Testing Tar and its Products."<sup>5</sup> Weigh accurately 4.99 to 5.01 g of the pyridine to be assayed and 14.95 to 15.05 g of the potassium chloride solution into the inner test-tube of this apparatus. When the final small additions are made, ensure that these are introduced well down the test-tube, so that the components can be completely mixed. Record the exact weight of each component.

Fit a Standardisation of Tar Products Tests Committee schedule T5C<sup>6</sup> thermometer, cork and stirrer into the test-tube, and adjust so that the bottom of the thermometer is 1 cm above the bottom of the tube. Stir briskly but without splashing, and bring the temperature to 25° C. Meanwhile, adjust the temperature of the water bath to 27.8°  $\pm$  0.2° C, with the air-jacket in place. Insert the inner tube, and stir the contents as the temperature rises, the temperature of the water bath being maintained at 27.8° C. Note the temperature at which the clear solution (pale blue by reflected light, owing to light-scattering) suddenly develops a milky white opacity, which is not dispersed by stirring. This is the solution temperature and can normally be read to within  $\pm$ 0.02° C. Check the solution temperature by cooling to 25° C, without removal of the thermometer and stirrer, and re-heating.

Determine the water content of the pyridine sample by the Karl Fischer method.<sup>1</sup> A knowledge of the water content is important because the presence of water reduces the concentration of pyridine in the mixture and dilutes the potassium chloride solution.

## CALCULATION—

Correct the observed solution temperature as follows—

- (i) Make the thermometer correction, if one is applicable.
- (ii) Calculate the percentage by weight of original sample in the total mixture, and correct the solution temperature by adding  $0.015^{\circ}\text{C}$  for each 0.01 per cent. w/w by which the sample concentration exceeds 25.00 per cent. w/w or by subtracting  $0.015^{\circ}\text{C}$  for each 0.01 per cent. w/w by which it is less than 25.00 per cent. w/w.
- (iii) Further correct the solution temperature by subtracting  $0.0085^{\circ}\text{C}$  for each 0.01 per cent. w/w of water in the sample.

Calculate the percentage of  $\alpha$ -picoline in the pyridine sample from the corrected solution temperature,  $t^{\circ}\text{C}$ , by using the equation—

$$\text{Amount of } \alpha\text{-picoline present, \% w/w} = (27.0 - t)/0.7.$$

## CONCLUSIONS

A programme of co-operative tests was carried out in our two laboratories to assess the precision of the proposed routine method. It was found that—

- (i) the repeatability<sup>4</sup> of a solution-temperature measurement for a given mixture was  $\pm 0.02^{\circ}\text{C}$ ,
- (ii) the repeatability<sup>4</sup> of a complete determination was  $\pm 0.04^{\circ}\text{C}$ ,
- (iii) the reproducibility<sup>4</sup> of the mean of two complete determinations by different analysts using different apparatus but the same potassium chloride solution was  $\pm 0.06^{\circ}\text{C}$ , and
- (iv) the reproducibility<sup>4</sup> of the mean of two complete determinations in which potassium chloride solutions of nominally the same concentration but prepared by different analysts were used was  $\pm 0.08^{\circ}\text{C}$ .

The last-named value is the most relevant when the uncertainty to be expected in the routine analysis of, for example, "pure pyridine (99 per cent. minimum)," is under consideration. It corresponds to an uncertainty in the  $\alpha$ -picoline content of about  $\pm 0.1$  per cent.

We are grateful for the interest shown by Dr. E. A. Coulson in this work. This paper is published by permission of the Director of the National Chemical Laboratory, and of the Directors of the Midland Tar Distillers Ltd.

## REFERENCES

1. Draft British Standard for Pyridine, CY (TPC) 3330.
2. Hamer, A., Pomfret, R., and Stubbings, W. V., *Analyst*, 1946, **71**, 419.
3. Andon, R. J. L., and Cox, J. D., *J. Chem. Soc.*, 1952, 4601.
4. Standardisation of Tar Products Tests Committee, "Standard Methods for Testing Tar and its Products," Fourth Edition, Gomersal, Leeds, 1957, p. 12.
5. —, *op. cit.*, p. 321.
6. —, *op. cit.*, p. 473.

Received November 27th, 1958

## DISCUSSION

MR. L. BREALEY asked what pre-treatment had been given to the potassium chloride in order to remove moisture and to ensure that the amount used was accurately reproducible.

MR. ADEY replied that the method adopted for removing moisture was to dry the potassium chloride (in the form of small crystals) in an oven at  $110^{\circ}\text{C}$  for 4 hours. It had been pointed out to the authors, after the completion of their work, that potassium chloride so dried might still contain a trace of moisture. For this reason, any analyst who wished to use the present calibration figures was recommended to adhere closely to the method given in the paper for preparing the potassium chloride solution.

DR. J. HASLAM asked if the difference in basicity of pyridine and  $\alpha$ -picoline could be exploited, and what was the accuracy of the gas-chromatographic determination of  $\alpha$ -picoline.

DR. COX said that the difference of basicity between pyridine and  $\alpha$ -picoline was not very great ( $K_{\text{B}}$  for pyridine in water =  $1.66 \times 10^{-9}$  and  $K_{\text{B}}$  for  $\alpha$ -picoline in water =  $9.1 \times 10^{-9}$ ; Andon, Cox and Herington, *Trans. Faraday Soc.*, 1954, **50**, 918), and no method exploiting this small basicity difference had yet been devised for the quantitative determination of one base in the presence of the other.

MR. ADEY added that  $\alpha$ -picoline in these concentrations could be measured by gas-liquid chromatography to within an estimated  $\pm 10$  per cent. of the amount present, provided that an internal-standard method was used. The authors were concerned, however, to devise a method that made use of inexpensive apparatus readily available in any laboratory.

# A Method for the Rapid Detection of Small Concentrations of Organic Bases in Urine

By P. J. MORGAN

(Department of Pharmacology, University of Melbourne, Australia)

A method is described for rapidly detecting small amounts of organic bases in biological fluids. It is specially suited to the use of paper-chromatographic methods of identification. Some experimental results for several different bases are given.

THE proposed micro-extraction procedure has been developed for detecting abnormal organic bases that may occur in urine or other biological fluids in concentrations of about 1 p.p.m. The method is simple and requires only a small amount of apparatus; it has been extensively tested in this laboratory for 3 years.<sup>1</sup> The procedure is essentially a two-stage extraction, the base being extracted from the urine with an immiscible organic solvent and then into a small volume of aqueous sulphuric acid (approximately 1  $\mu$ l) supported on filter-paper.

The procedure yields an extract in a form suitable for further resolution and purification by paper chromatography. However, the original considerations leading to the development of the method emerged during a general mathematical investigation of such a two-stage extraction procedure and indicated that not only highly concentrated but also highly selective yields of a base could be expected when the volume of the second aqueous phase was extremely small.

## METHOD

### APPARATUS—

The acid-spot extraction apparatus is shown in Fig. 1. To remove last traces of oxygen from the nitrogen, the gas is passed through a solution of chromous sulphate; it is then dried by bubbling through concentrated sulphuric acid and passed through a U-tube containing self-indicating silica gel, which serves as a check on the efficiency of the acid and as a trap for acid spray. The tip of the delivery tube, D, should have an orifice small enough to give a steady stream of small bubbles.

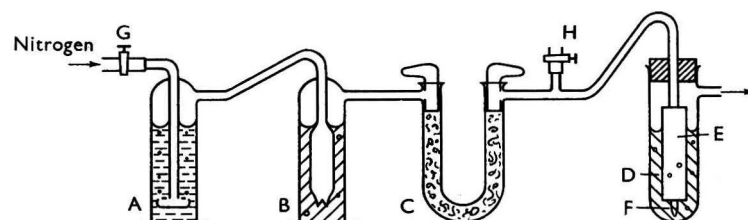

- |   |                                 |
|---|---------------------------------|
| A = Washing bottle containing chromous sulphate solution  | D = Solvent extract             |
| B = Washing bottle containing concentrated sulphuric acid | E = Paper strip with acid spots |
| C = U-tube containing self-indicating silica gel          | F = Tip of gas delivery tube    |
|   | G = Screw clip                  |
|   | H = By-pass to flowmeter        |

Fig. 1. Diagram of acid-spot extraction apparatus

The chromous sulphate solution is prepared *in situ* in a gas-washing bottle fitted with a sintered-glass disc on the inlet tube and having a ground-glass neck. Twelve grams of powdered chromic potassium sulphate are stirred with 50 ml of water and 5 ml of concentrated sulphuric acid are added. When the chromic potassium sulphate has completely dissolved, the solution is cooled by adding 10 to 15 g of crushed ice and is poured on to 3 g of zinc dust in the bottom of the gas-washing bottle. The inlet tube is immediately inserted and air is expelled by passing a slow stream of nitrogen through the bottle for a time. When reduction is complete the solution is pale blue; it darkens as oxygen is absorbed.<sup>2</sup>

## GENERAL PROCEDURE FOR DETECTING MORPHINE OR OTHER TYPICAL ALKALOIDS—

The urine sample is adjusted to pH 9.0 by adding a 20 per cent. solution of sodium hydroxide; ammonia solution must not be used. (This pH favours the detection of morphine; factors that should be considered if other bases are specifically sought are the ionisation constants of the base and its partition constant between the solvent used for extraction and water. Bases similar in strength to morphine but more soluble in chloroform are selectively extracted at lower pH values; others stronger than morphine but having similar solubility in chloroform are selectively extracted at higher pH values.)

The sample at pH 9.0 is extracted once with about one-fifth of its volume of chloroform. (At least 20 ml of solvent are used if the volume of sample is small.) Any standard method of extraction may be used; a convenient method is described below.

As much as possible of the chloroform extract is filtered through a dry filter-paper into a test-tube of diameter such that the height of liquid is 5 to 7 cm.

A strip of Whatman 3MM filter-paper, 7 cm  $\times$  1.5 cm, is spotted 2 cm from one end with drops of 0.25 and 0.5 *N* sulphuric acid. (It is advantageous, but not essential, that the sulphuric acid should contain thymol blue indicator. The 0.25 and 0.5 *N* sulphuric acid-thymol blue reagent solutions are prepared by dissolving separate 4.0-mg portions of thymol blue indicator in 0.5 and 1.0 g of concentrated sulphuric acid, respectively, in 50-ml stoppered flasks. The solutions are set aside overnight and then each is diluted to 40 ml with distilled water.) The filter-paper should be purified by washing chromatographically with chloroform and then water before it is cut into strips. The acid spots can be applied with a loop of platinum wire adjusted to produce spots 3 to 5 mm in diameter.

Immediately after it has been spotted with acid, the paper strip is placed in the chloroform extract so that the spots (and preferably the entire strip) are completely immersed. The extract is then agitated with a stream of dry oxygen-free nitrogen, which passes into the test-tube through a glass delivery tube, the lower end of which should be below the acid spots (see Fig. 1). The acid spots should not be in contact with the delivery tube or the walls of the test-tube. The nitrogen flow rate should be  $100 \pm 50$  ml per minute per 20 ml of solvent. A flowmeter of the type described by James and Martin<sup>3</sup> can be used. This should be placed in parallel with the apparatus and the gas stream by-passed through it when a reading is to be taken. If placed in series with the apparatus, undesirable condensation of water may occur in the solvent extract.

After some minutes the spots become transparent owing to loss of water. If a high concentration of base is expected the strip may then be removed from the chloroform. The gas flow is stopped and any part of the strip not immersed is rinsed with the extract by shaking for a few minutes. Excess of chloroform is removed by shaking or blotting the strip and exposing it to a current of air.

The dried strip is then suspended in a flask over a few drops of concentrated ammonia solution until the spots change from pink to yellow or blue (about 15 seconds).

After removal of ammonia vapour in a current of air, the resulting mixture of sulphates of bases extracted from the urine and ammonium sulphate is developed on the strip as a paper chromatogram by any convenient modification of Rockland and Dunn's ascending-solvent technique.<sup>4</sup> Suitable solvent systems and spray reagents are described under "Paper Chromatography of Acid-spot Extracts."

In order to detect bases present at lower levels of concentration, the procedure, from the application of acid spots, may be repeated on further strips, either together or consecutively, and with longer times of agitation. Alkaloid concentrations of 1 p.p.m. in the original urine sample are extracted in microgram amounts, which can be detected<sup>5</sup> after less than 15 minutes' agitation. Much lower concentrations can be detected after longer agitation or simply by immersing the strip in the chloroform extract overnight without passing nitrogen.

## EXTRACTION OF URINE WITH CHLOROFORM—

The solvent is introduced into a cylindrical separating funnel, the tap of which is greased with a starch-glycerol paste. The urine, after adjustment of pH, is carefully poured on to the chloroform phase so that no emulsification occurs. A slow stream of nitrogen (less than 50 ml per minute) is then passed into the lower chloroform layer. Droplets of solvent are continuously carried by the gas up through the aqueous layer. The rate of gas flow is adjusted so that the coarse emulsion formed at the interface does not extend as far down as the tip of the gas-delivery tube. After 20 minutes the gas is shut off; any residual emulsion

that does not separate on standing is broken up as far as possible by gentle stirring. Acid-spot extraction is then applied to the separated solvent phase. It is not essential that the whole of the solvent phase be used, nor is it essential that extraction of the urine be carried to equilibrium.

#### PAPER CHROMATOGRAPHY OF ACID-SPOT EXTRACTS

For the detection of typical alkaloids it is recommended that the strips be developed in the organic-rich phase of a mixture of 50 ml of *n*-butyl alcohol, 10 ml of concentrated hydrochloric acid and 20 ml of water, which gives  $R_f$  values in the range 0.2 to 0.8 for most alkaloids. Detection is achieved by spraying with an iodoplatinate reagent solution having the following composition.

Chloroplatinic acid solution, 5 per cent.	..	..	..	20 ml
Potassium iodide solution, 4 per cent.	..	..	..	250 ml
Water	..	..	..	200 ml

This solution keeps indefinitely and can be used in this form for the detection of alkaloids.<sup>5</sup> However, it is preferable to add 3 ml of concentrated hydrochloric acid per 47 ml of this reagent and to prepare the solution freshly from time to time. The acidified spray reagent is more sensitive towards some bases, notably caffeine. The reagent gives violet to blue spots on a pink background.

Some sympathomimetic amines, such as amphetamine and ephedrine, are more readily detected by developing in a one-phase system consisting of 20 ml of *isobutyl* methyl ketone, 10 ml of acetic acid and 5 ml of water and spraying with a dilute solution of bromocresol green in ethanol. When exposed to a current of air, these bases gradually develop as blue spots on a yellow-green background. A fine spray is essential for the best results; if the chromatogram has been thoroughly dried before it is sprayed and a thick paper, such as Whatman 3-MM, is used, it is often possible to spray the reverse of the chromatogram with a different reagent if desired.

When it is desired to run longer chromatograms, an acid-spot extract is prepared from larger spots of the sulphuric acid - thymol blue reagent on a piece of paper of convenient size, which is subsequently joined to two longer pieces of paper by some suitable means, such as sandwiching the three pieces of paper, with the minimum possible overlap, between two pieces of glass of somewhat larger dimensions than conventional microscope slides. The assembly is clamped together at the ends with spring-type wooden clothes pegs, and a chromatogram is developed by the ascending-solvent technique.

#### DISCUSSION OF THE METHOD

If much basic material is present in the urine, as in urine that has been stored for some days at room temperature, the spots may become neutral (yellow) to thymol blue on prolonged agitation. If this occurs, cations of bases initially extracted may become displaced from the spot by those of bases stronger than the class of base it is desired to detect. (It is for this reason that ammonia cannot be used for the adjustment of pH.) It is therefore necessary to watch for any change of colour in the 0.25 *N* sulphuric acid spot, and if this occurs the strip should be removed immediately and replaced by a fresh strip.

Occasionally, dark-coloured material is extracted on to the spot and obscures the pink colour of the thymol blue; it is then necessary to check that the spots have retained their acidity by applying a little thymol blue dissolved in ethanol to them before suspending the strips over ammonia solution.

Some typical results indicative of the performance of the method are shown in Figs. 2, 3, 4 and 5, which give the times required for the extraction of the minimum detectable amounts of bases from solutions of various concentrations. To obtain reproducible and comparable results, the acid spots were allowed to dry in air before agitation in the solvent was commenced. Normally, it is not necessary to do this; spots immersed immediately after application to the paper soon lose their excess of moisture in the solvent, provided the nitrogen stream is dry (this is essential for a maximum rate of extraction). Detection was also achieved by spraying with iodoplatinate reagent solution immediately after the last traces of solvent had evaporated from the strip after removal, and without prior exposure to ammonia vapour. It should be pointed out that, if the extracts are developed as a paper chromatogram, times of detection may be ten times longer than those shown in Figs. 2, 3, 4 and 5 for a given con-



centration, depending on the degree of diffusion that occurs with the chromatographic solvent and length of development used.

The extraction times shown in Fig. 2 were determined by dissolving caffeine base, for which  $pK_b$  is greater than 13,<sup>6</sup> in six solvents and determining the times of first appearance of

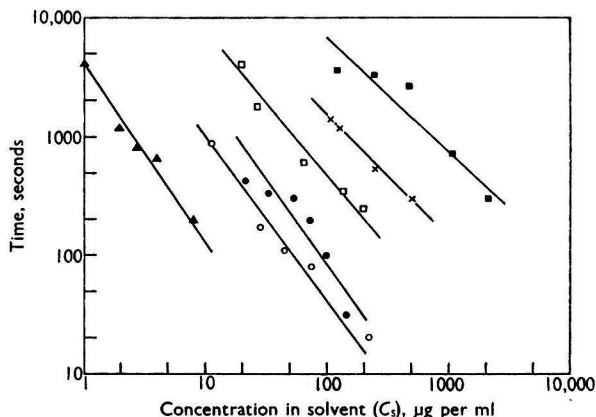

Fig. 2. Time required for extraction of minimum detectable amount of caffeine from various solvents:  $\blacktriangle$ , cyclohexane;  $\circ$  chloroform-cyclohexane mixture (1 + 5 v/v);  $\bullet$ , carbon disulphide;  $\square$ , chloroform-cyclohexane mixture (1 + 1 v/v);  $\times$ , chloroform;  $\blacksquare$ , ethylene dichloride

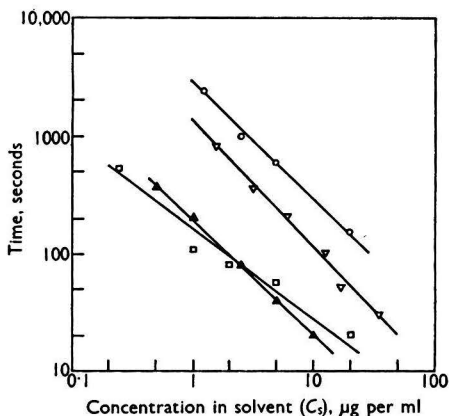

Fig. 3. Time required for extraction of minimum detectable amount of cocaine from various solvents:  $\blacktriangle$ , cyclohexane;  $\nabla$ , chloroform;  $\circ$ , nitrobenzene;  $\square$ , ethylene dichloride

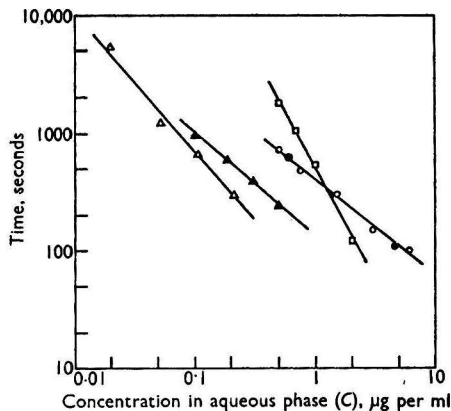

Fig. 4. Time required for two-stage extraction of minimum detectable amounts of nicotine and morphine from aqueous solutions:  $\triangle$ , nicotine in pH 8.0 buffer solution extracted with chloroform;  $\blacktriangle$ , nicotine in pH 6.5 buffer solution extracted with chloroform;  $\square$ , nicotine in pH 8.0 buffer solution extracted with light petroleum, boiling range 100° to 110° C;  $\circ$ , morphine in pH 8.0 buffer solution extracted with chloroform;  $\bullet$ , morphine in pH 8.0 buffer solution extracted with chloroform-ethanol mixture (10 + 1 v/v)

a detectable amount of base on the acid spots for solutions of various degrees of dilution. Fig. 3 shows a similar set of results for the stronger base cocaine, for which  $pK_b$  is 5.6.<sup>7</sup>

The time for initial detection in seconds is plotted on a log scale against the concentration in  $\mu\text{g}$  per ml in the solvent phase ( $C_s$ ), also shown on a log scale. From the slope of the lines

it is evident that the initial rate of extraction of base is usually approximately proportional to the concentration in the solvent phase.

The rates of extraction of the weaker base caffeine are much less than those of cocaine at similar concentrations, except with *cyclohexane*, in which caffeine is much less soluble than it is in water. Hence it is evident that both the ionisation constant of the base and the partition constant (for un-ionised base) between solvent and water play a part in determining rates of extraction from the solvent phase.

Figs. 4 and 5 show results obtained by shaking freshly prepared solutions of nicotine hydrogen tartrate and morphine hydrochloride in aqueous phosphate buffer solutions with one-fifth of their volume of solvent, and applying acid-spot extraction to the separated organic phase. Times of initial detection are plotted against the concentration ( $C$ ) of base initially

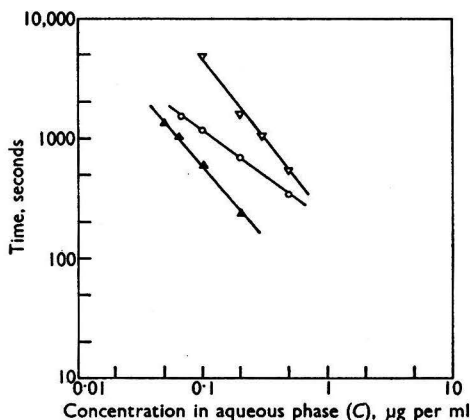

Fig. 5. Time required for two-stage extraction of minimum detectable amounts of nicotine from aqueous buffer solution at pH 8.0 with various solvents: ▲, chloroform - *cyclohexane* mixture (1 + 1 v/v); ▽, chloroform - *cyclohexane* mixture (1 + 6 v/v); ○, ethylene dichloride

present in the aqueous phase. Both these bases are similar in strength to cocaine,<sup>7,8</sup> but when extraction times are compared with those in Fig. 3 it should be borne in mind that nicotine, by virtue of its high solubility in chloroform, is present in much higher concentration in the solvent phase than in the original aqueous phase. This effect of concentration by extraction is only partly off-set by decreasing the pH from 8.0 to 6.5, although nicotine exists predominantly in the ionised form in the aqueous phase at pH 6.5, the ionisation equilibrium being shifted by the extraction process. Further, from the results for morphine it is evident that minor changes in solvent composition have little effect on the final result when a two-stage extraction procedure is used. In this connection it should be remarked that, in order to extend the method to the detection of extremely weak bases, such as caffeine, in concentrations similar to those at which the typical alkaloids can be detected, it is necessary to extract first with an efficient solvent, such as chloroform, which is then almost entirely removed by evaporation and replaced with a non-solvent, such as *cyclohexane*, care being taken to ensure that no solid phase is precipitated.

I acknowledge that this work was made possible by a grant from the Victoria Racing Club.

#### REFERENCES

1. Troy, C. A., Gershon, S., and Morgan, P. J., *Med. J. Australia*, 1958, **2**, 667.
2. Stone, H. W., and Beeson, C., *Ind. Eng. Chem., Anal. Ed.*, 1936, **8**, 188.
3. James, A. T., and Martin, A. J. P., *Biochem. J.*, 1952, **50**, 679.
4. Rockland, L. B., and Dunn, M. S., *Science*, 1949, **109**, 539.
5. Mannering, G. J., Dixon, A. C., Carroll, N. V., and Cope, O. B., *J. Lab. Clin. Med.*, 1954, **44**, 292.
6. Turner, A., and Osol, A., *J. Amer. Pharm. Ass., Sci. Ed.*, 1949, **38**, 158.
7. Kolthoff, J. M., *Biochem. Z.*, 1925, **162**, 353.
8. Fowler, R. T., *J. Appl. Chem.*, 1954, **4**, 449.

Received December 30th, 1958

ห้องสมุด กรมวิทยาศาสตร์

## The Determination of DDT Residues in Foodstuffs

By G. A. SERGEANT\* AND R. WOOD

(Department of the Government Chemist, Clement's Inn Passage, Strand, London, W.C.2)

A method is described for determining residues of DDT in a variety of foodstuffs, including fats and fatty materials.

VARIOUS modifications of two basic methods for determining residues of DDT [1:1:1-trichloro-2:2-di(*p*-chlorophenyl)ethane] are in general use; the basic methods are those described by Schechter, Soloway, Hayes and Haller<sup>1</sup> and by Stiff and Castillo.<sup>2</sup> The first is the more widely used and in one form has been adopted by the Association of Official Agricultural Chemists<sup>3</sup>; the second is of some interest owing to its greater operational simplicity. Also, unlike Schechter, Soloway, Hayes and Haller's method it is, under suitable conditions, not affected by the relative proportions of the two principal isomers present in technical DDT and is specific for DDT in the presence of DDD. During our investigation, two serious objections to Stiff and Castillo's method have been encountered, *i.e.*, rapid fading of the colour given by the pyridine - xanthhydrol reagent with DDT and the extreme susceptibility of the colour to disturbance, apparently by atmospheric moisture, which cannot conveniently be completely excluded.

Schechter, Soloway, Hayes and Haller's method involves two main operations—nitration of the DDT and colour development by the action of methanolic sodium methoxide on the tetranitro-derivative. Quantitative, or at least reproducible, nitration of DDT is rendered uncertain by the presence of extraneous organic matter, such as normally accompanies DDT in extracts of foodstuffs and which is liable to be oxidised with some violence by the nitration acid with consequent loss of DDT. In the Association of Official Agricultural Chemist's method, careful regulation of the nitration by temperature control is intended to obviate this source of error. Preliminary reduction of the extraneous organic matter present to a sufficiently low level is also effective and permits rapid nitration without significant loss of DDT. Nitration is complete in 15 minutes at 100° C,<sup>4</sup> but some prolongation of the nitration time is desirable to allow more complete oxidation of impurities, which may otherwise give rise to interfering background colours in the colorimetric stage.

The use of ethanolic potassium hydroxide as the chromogenic agent<sup>5</sup> in place of methanolic sodium methoxide is preferred, as it is much simpler to prepare; moreover, it has been found that the addition of urea considerably improves the keeping quality of this reagent by greatly delaying the tendency to develop a yellow colour.

Typical procedures for the separation of DDT and other acid-resistant pesticides from fatty materials have been described by Schechter, Pogorelskin and Haller<sup>6</sup> and by Davidow.<sup>7</sup> The procedure described in this paper deals with comparatively large amounts of fat by a form of sulphuric acid treatment incorporating some features of both these methods. After the acid treatment, further purification of the extract is usually required in preparation for the colorimetric test, and a chromatographic stage has been added in which DDT is selectively adsorbed on a small silica gel column. Similar adsorption of DDT on an alumina column was found to result in low recoveries, especially if elution was delayed, apparently by gradual dehydrochlorination of the DDT.

The procedure devised primarily for fats is also applicable, with slight modifications, to the purification of extracts of non-fatty plant material and was found to be more effective than treatment by chromatography on alumina or magnesia columns.

The loss of DDT occurring when solutions are evaporated to dryness on a steam-bath is greatly reduced by adding a small amount of non-volatile liquid. Of several liquids tested for this purpose, only propylene glycol was found to cause negligible interference in the colorimetric operation.

### METHOD

#### APPARATUS—

*Chromatographic tube*—A filter tube, 30 mm × 200 mm, fitted with a No. 1 sintered-glass plate.

\* Present address: Geological Survey & Museum, Exhibition Road, London, S.W.7.

*Tube for silica gel*—A glass tube, 200 mm in length and 16 mm internal diameter, which tapers at the lower end to retain a cotton-wool plug.

*Evaporator*—A simple form of Kuderna - Danish evaporator, such as has been previously described<sup>8</sup>; liquid paraffin must not be used to lubricate the ground-glass joints of this apparatus.

#### REAGENTS—

*Hexane*—The aromatic hydrocarbon content must be low. Standard hexane, obtained from Carless, Capel and Leonard Ltd., is suitable.

*Acetone*—The redistilled grade is suitable.

*Celite 545*.

*Sodium sulphate, anhydrous*.

*Sulphuric acid, concentrated*.

*Sulphuric acid mixture*—Mix equal volumes of concentrated sulphuric acid and fuming sulphuric acid containing 20 per cent. of sulphur trioxide.

*Silica gel*—The grade supplied for chromatography by Hopkin and Williams Ltd. is suitable. Dry by heating for several hours at 250° C.

*Diethyl ether*—Analytical-reagent grade.

*Amyl alcohol*—Analytical-reagent grade.

*Nitration acid*—Mix equal volumes of fuming nitric acid and concentrated sulphuric acid, both of analytical-reagent grade.

*Extraction solvent*—Mix 2 volumes of light petroleum, boiling range 40° to 60° C, and 1 volume of analytical-reagent grade benzene.

*Sodium hydroxide solution, 5 per cent. w/v, aqueous*.

*Sodium chloride solution*—A saturated aqueous solution.

*Benzene*—Analytical-reagent grade.

*Ethanolic potassium hydroxide solution*—Dissolve 5 g of analytical-reagent grade potassium hydroxide and 2 g of analytical-reagent grade urea by heating under reflux with 100 ml of absolute ethanol, cool, and filter the solution. Store in a bottle having a well fitting stopper.

*Propylene glycol*—Redistilled.

#### PROCEDURE FOR EXTRACTING DDT—

*Fats, oils and fatty materials*—Place 4 g of Celite 545 in the chromatographic tube, add 8 g of Celite 545 thoroughly mixed with 4 ml of sulphuric acid mixture, pack firmly and uniformly, and finally add a 1-cm layer of anhydrous sodium sulphate. Dissolve the sample, containing up to 25 g of fat, in 100 ml of hexane in a 500-ml flask. Extract incompletely soluble samples with hexane in a Soxhlet or similar extraction apparatus. To the solution add 40 ml of sulphuric acid mixture in several portions, and swirl the contents of the flask vigorously for about 30 seconds after each addition. If much heat is generated, allow suitable intervals for cooling between additions of the acid mixture. After the final addition of the acid mixture, set the flask aside for not less than 30 minutes to allow separation, and then decant the hexane into the prepared chromatographic tube. When the column has drained, wash the acid mixture in the flask with three successive 75-ml portions of hexane. For each washing, swirl the contents of the flask vigorously for about 30 seconds, and, after at least 15 minutes for separation, decant the hexane into the chromatographic tube. (If emulsification causes slow separation, it is sometimes advantageous to add one or two 5-ml portions of amyl alcohol to the liquid, and, if necessary, to allow the final separation to take place overnight.) Collect the combined drainings from the column in the evaporator, and reduce the volume of solvent to a few millilitres.

Stir 8 g of silica gel into a thin slurry with hexane, and rinse the slurry with more hexane into the glass tube containing the cotton-wool plug. Rinse the evaporator with a little hexane, detach the 25-ml flask, and rinse its contents into the prepared tube with a few millilitres of hexane. When the silica gel has drained, wash the column with four successive 15-ml portions of hexane. Reject the washings, and drain the column thoroughly by applying air pressure to the top of the tube. Elute the DDT by washing the column with four successive 15-ml portions of diethyl ether. Add 2 drops of propylene glycol to the ether solution, and reduce the volume to a few millilitres in the evaporator. Remove the remaining solvent at 40° C by means of a current of dry air, and stand the flask on a steam-bath for 30 minutes.

**Butter**—Warm 25 g of butter and 50 ml of hexane in a 100-ml beaker until dissolution is complete. Cool the solution, allow the aqueous layer to separate, and decant the upper layer into a glass tube containing a few grams of anhydrous sodium sulphate supported on a cotton-wool plug. Wash the aqueous layer and the sodium sulphate with three successive 15-ml portions of hexane, and collect the drainings from the tube in a 500-ml flask. From this point, continue as described above under "Fats, oils and fatty materials."

**Milk**—To 100 g of chilled milk in a 500-ml flask, slowly add 50 ml of concentrated sulphuric acid; swirl the contents of the flask during the addition. Cool, transfer the mixture to a 250-ml separating funnel, rinse the flask with two 50-ml portions of hexane, and add the rinsings to the contents of the separating funnel. Add 5 ml of amyl alcohol, and shake the mixture vigorously for 1 minute. After 30 minutes, run off and reject the aqueous layer, and rinse the hexane extract into the original flask with hexane. From this point, continue as described under "Fats, oils and fatty materials," but add 10 ml of concentrated sulphuric acid instead of 40 ml of sulphuric acid mixture.

**Non-fatty plant materials**—Extract and purify the residues of chlorinated hydrocarbon pesticides as previously described,<sup>8</sup> and transfer the final extract to a 500-ml flask. Continue as described under "Fats, oils and fatty materials," but add 10 ml of concentrated sulphuric acid instead of 40 ml of sulphuric acid mixture; also, use concentrated sulphuric acid instead of fuming sulphuric acid in the preparation of the Celite 545 - acid column.

**Grain**—It is necessary to treat grain as a slightly fatty material. Extract up to 50 g of ground grain with hexane in a Soxhlet extractor. Transfer the extract to a 500-ml flask, and continue as described under "Fats, oils and fatty materials," but add 10 ml of sulphuric acid mixture instead of 40 ml.

#### PROCEDURE FOR NITRATION AND COLOUR DEVELOPMENT—

Cool the flask, and to the residue, which should contain between 0.01 and 1 mg of DDT, add 2 ml of nitration acid. Swirl the liquid, and transfer the flask to a steam-bath. After 30 minutes, cool the flask, and pour the contents into a separating funnel containing about 25 ml of water. Rinse the flask with about 25 ml of water and then with not more than 10 ml of acetone, and add the rinsings to the contents of the separating funnel. Add 25 ml of extraction solvent, and shake the stoppered funnel vigorously for 1 minute. Separate and discard the aqueous layer. Add 10 ml of 5 per cent. w/v sodium hydroxide solution, and shake the mixture for 30 seconds. Separate and discard the aqueous layer, and repeat the washing with 10-ml portions of alkali until the washings are virtually colourless. Drain off the final aqueous layer, add about 20 ml of saturated sodium chloride solution, shake vigorously, and then separate and discard the aqueous layer.

By pipette, place a suitable aliquot of the solution from the separating funnel in a small stoppered flask or weighing bottle, and evaporate to dryness at 40° C by means of a current of dry air. Stand the unstoppered flask on a steam-bath for 30 minutes, cool, and dissolve the residue in 1 ml of benzene (added by pipette in such a way as to wash down the sides of the flask). Add 5 ml of ethanolic potassium hydroxide solution with swirling, replace the stopper, allow the colour to develop for 4 minutes, and measure the optical density of the solution in a 1-cm cell at 600 m $\mu$ .

#### PREPARATION OF CALIBRATION CURVE—

Prepare a hexane solution containing 0.04 mg of *pp'*-DDT per ml. By pipette, place 1 ml of this solution in a 25-ml flask, evaporate to dryness at 40° C by means of a current of dry air, and continue as described above with nitration and extraction. By pipette, take a 5-ml aliquot of the nitrated DDT solution from the separating funnel, and carry out the colour development and measurement. Proceed similarly with further aliquots up to 10 ml of the original DDT solution, and plot a graph of optical densities of the 5-ml aliquots against micrograms of *pp'*-DDT present.

#### EFFECT OF DDT ISOMERS

Technical DDT may contain up to about 20 per cent. of *op'*-DDT, which gives a reddish violet colour in the colorimetric stage of the determination with about 60 per cent. of the optical density of an equal amount of the *pp'*-isomer at the wavelength used. If a precise determination of *pp'*-DDT is required, the proportion of *op'*-DDT present can be determined

by a technique involving measurement of the optical densities of the coloured solution at two wavelengths (580 and 510  $m\mu$ ) and the preparation of calibration curves for both pure isomers, as described by Wichmann, Patterson, Clifford, Klein and Claborn<sup>4</sup> and in the Association of Official Agricultural Chemist's method.<sup>3</sup>

TABLE I  
RECOVERY OF DDT ADDED TO FATS AND OILS

Sample	Amount of <i>pp'</i> -DDT added, p.p.m.	Amount of <i>pp'</i> -DDT found, p.p.m.	Recovery, %	Apparent amount of <i>pp'</i> -DDT in untreated control material, p.p.m.
Butter .. ..	4.0	3.7	92	0.19
Suet .. ..	4.0	3.45	86	0.25
Milk .. ..	1.0	0.93	93	0.11
Rape oil .. ..	4.0	3.6	90	0.64
Linseed oil .. ..	4.0	3.6	90	0.22
	20.0	19.0	95	0.09
Olive oil .. ..	4.0	3.45	86	0.20
Castor oil .. ..	4.0	3.6	90	0.10
Groundnut oil .. ..	8.0	7.2	90	0.80
	20.0	18.2	91	0.11

### RESULTS

Table I shows the results found when various oils and fatty materials, to which DDT had been added, were analysed by the proposed method. The figures for *pp'*-DDT found have been corrected for apparent DDT in the untreated control material.

We thank the Government Chemist for permission to publish this paper.

### REFERENCES

1. Schechter, M. S., Soloway, S. B., Hayes, R. A., and Haller, H. L., *Ind. Eng. Chem., Anal. Ed.*, 1945, **17**, 704.
2. Stiff, H. A., and Castillo, J. C., *Science*, 1945, **101**, 440.
3. Horwitz, W., Editor, "Official Methods of Analysis of the Association of Official Agricultural Chemists," Eighth Edition, The Association of Official Agricultural Chemists, Washington, 1955, p. 406.
4. Wichmann, H. J., Patterson, W. I., Clifford, P. A., Klein, A. K., and Claborn, H. V., *J. Ass. Off. Agric. Chem.*, 1946, **29**, 188.
5. Martin, J. T., and Batt, R. F., *Ann. Rep. Agric. Hort. Res. Sta., Bristol*, 1953, 121.
6. Schechter, M. S., Pogorelskin, M. A., and Haller, H. L., *Anal. Chem.*, 1947, **19**, 51.
7. Davidow, B., *J. Ass. Off. Agric. Chem.*, 1950, **33**, 130.
8. Sergeant, G. A., *Analyst*, 1958, **83**, 335.

Received January 28th, 1959

## The Determination of Boron in Plain-carbon and Alloy Steels

By J. BORROWDALE, R. H. JENKINS AND C. E. A. SHANAHAN

(Central Research Laboratories, Richard Thomas & Baldwins Ltd., Whitchurch, Aylesbury, Bucks.)

A study has been made of certain variables in a methyl borate distillation procedure for the determination of total boron in steel by the curcumin colour reaction. This has led to a procedure that can be used for plain-carbon and alloy steels. A single determination takes approximately 3 hours, assuming that the initial dissolution of the sample does not take longer than 30 minutes.

Results are presented to show the accuracy and precision of the method when applied to boron contents between 0.002 and 0.100 per cent. in steels of widely different compositions.

IN recent years there has been considerable interest in the determination of boron in metals. Its high thermal-neutron capture cross-section makes it a most undesirable impurity in atomic pile construction materials, and details of several investigations into the determination of boron have been published by workers in the field of atomic energy. The iron and steel

industry has also devoted considerable attention to boron, since it is now known that the presence of as little as 0.001 to 0.005 per cent. of boron can cause important differences in the mechanical properties of steel. Moreover, attempts are now being made to produce rimming steel with boron stabilisation of the nitrogen content.

In most of the published methods, a colorimetric finish is used, although spectrographic,<sup>1,2,3</sup> polarographic<sup>4,5</sup> and fluorimetric<sup>6</sup> procedures have been described. The colorimetric procedures can conveniently be divided into two general groups. In the first group, the colorimetric reagent, *e.g.*, anthraquinone derivatives, such as quinalizarin, dianthrimide and carminic acid, is dissolved in concentrated sulphuric acid. Boron has been determined in high-temperature alloys<sup>7</sup> by using quinalizarin and in aluminium<sup>8</sup> and titanium<sup>9</sup> alloys by using dianthrimide. In addition, certain steelworks laboratories prefer this group of reagents; a method has been recommended<sup>10</sup> in which quinalizarin is used, and recently the Methods of Analysis Committee of the British Iron and Steel Research Association has suggested a procedure based on dianthrimide.<sup>11</sup>

The second group involves colorimetric reagents that do not require reaction with boron in concentrated acid to yield quantitative results. Curcumin is a well known example of this group; it reacts with boric acid in alcoholic or aqueous media and has been used to determine boron in nickel,<sup>12</sup> uranium,<sup>13</sup> sodium,<sup>14</sup> silicon, germanium<sup>15</sup> and steels.<sup>16</sup>

The method described in this paper involves a preliminary separation of the total boron as trimethyl borate by distillation and then a colorimetric determination with curcumin. It thus avoids the use of concentrated sulphuric acid and a lengthy (16 hours<sup>11</sup>) development stage; a determination can be completed in approximately 3 hours if the initial dissolution of the sample takes approximately 30 minutes. The method covers the determination of total boron, and no attempt has been made to differentiate between acid-soluble and insoluble boron constituents. However, since the sample is decomposed in dilute sulphuric acid under controlled conditions, the method can be easily adapted to treat acid-soluble and insoluble fractions if such information is required.

#### EXPERIMENTAL

It was decided to divide the investigation into three sections—

- (i) Determination of the accuracy of the curcumin technique as judged by the addition of known amounts of boron to a solution corresponding to a typical distillate.
- (ii) A study of the efficiency with which the distillation process separates the boron as methyl borate.
- (iii) Application of the technique to steel samples.

#### THE CURCUMIN - BORATE REACTION—

Chirside, Cluley and Proffitt<sup>12</sup> stated that the colour produced by this reaction is influenced by such variables as temperature, time of heating, proportion and manner of addition of reagents, etc., and they understandably made no attempt to examine all possible variations. We have found that, if strictly controlled conditions are maintained, boron determinations are reproducible.

The first series of experiments was carried out in the absence of methanol on a solution of a borate in sodium hydroxide. Known amounts up to 10 ml of a standard solution containing 1  $\mu\text{g}$  of boron per ml and then 5 ml of 0.1 *N* sodium hydroxide were placed in clean dry 80-ml platinum dishes of diameter 70 mm. After they had been mixed, the solutions were evaporated to dryness on a water bath, and 1.0 ml of a 6 per cent. w/v solution of oxalic acid in 20 per cent. v/v hydrochloric acid and 5.0 ml of a 0.025 per cent. w/v solution of curcumin in industrial ethanol were added to each residue. The solutions were mixed, and then evaporated to dryness by floating the platinum dishes on a water bath at  $55^\circ \pm 1^\circ \text{C}$ . Heating was continued for 30 minutes after free hydrochloric acid had been removed (as judged by odour). When cool, the residues were extracted with a (1 + 1) mixture of acetone and water and the extracts were accurately diluted to volume with the acetone - water mixture in 50-ml calibrated flasks. After they had been well mixed, the solutions were filtered through dry filter-papers into 1-cm cells and the optical densities were measured with a Spekker absorptiometer, a mercury-vapour lamp and Ilford No. 605 filters being used. Table I shows the results of this series of experiments (corrected for the reagent blank value).

TABLE I  
EFFECT OF METHANOL ON CURCUMIN - BORATE COLOUR

Amount of boron present, $\mu\text{g}$	Corrected optical density in absence of methanol	Corrected optical density in presence of 120 ml of methanol
2.5	0.228	—
5.0	0.438	0.382
7.5	0.668	0.588
10.0	0.874	0.572
		0.570
		0.770

The distillate from a determination of boron in steel differs from the above conditions in that it contains methanol. The second series of experiments was therefore a repetition of the first, but methanol was added to the alkaline standard boron solution. Previous work suggested that distillate volumes would be approximately 125 ml, and 120 ml of methanol were therefore placed in each platinum dish. The results of this series of experiments are also shown in Table I, and it can be seen that reproducibility is good if the evaporation conditions, etc. are kept constant. However, comparison of the two series shows that the presence of methanol decreases the optical density for a given boron content by approximately 10 per cent. The presence of methanol, therefore, either suppressed the curcumin - borate colour in some way or, more probably, caused a loss of boron. It is reasonable to suppose that boron might be volatilised as methyl borate during the evaporation stage, as suggested by Spicer and Strickland.<sup>17</sup> Some workers have advised the addition of glycerol to prevent boron losses during evaporation with methanol, and a few experiments in which glycerol was used were made in the present investigation. Unfortunately, boron yields were not improved; when glycerol was added to aqueous alkaline boron solutions in the absence of methanol, boron recovery decreased, presumably owing to the higher temperatures needed for removal of glycerol.

#### EFFICIENCY OF DISTILLATION PROCEDURE—

Although the treatment of the distillate for the determination of boron with curcumin gave reduced optical densities owing to the presence of methanol during the evaporation stage, the calibration graph of optical density against boron concentration was reproducible. Experiments were therefore conducted with known amounts of boron. Four millilitres of 20 per cent. v/v sulphuric acid (the amount of aqueous acid considered to be necessary for dissolution of a steel sample) and a known amount of standard boron solution were placed in a 600-ml boron-free-glass distillation flask. The flask was fitted with a boron-free-glass condenser and a separating funnel through which methanol could be passed during distillation. Distillation was continued until approximately 125 ml of distillate had been collected in a platinum dish containing 5 ml of 0.1 N sodium hydroxide and the residue in the flask was approximately 5 ml. The distillate was treated as described previously. This procedure was repeated at several different levels of boron and the optical densities of the final solutions were measured in 1-cm cells; the results, corrected for the reagent blank value, were as follows—

Amount of boron added, $\mu\text{g}$	..	..	..	2.5	5.0	7.5	7.5	7.5
Optical density	..	..	..	0.228	0.323	0.408	0.566	0.462

Comparison of these results with those in Table I shows that the distillation was responsible for some loss of boron. Further experiments showed that this loss occurred mainly by retention of boron on the distillation assembly. Additional boron was recovered when extra methanol was added to the flask and the distillation was resumed.

At this stage, it seemed obvious that a reduction in the size of the distillation unit would be advantageous. Not only would a smaller flask and condenser be less likely to retain boron, but the use of less methanol would decrease the evaporation time of the distillate and thereby tend to reduce any simultaneous loss of boron. The apparatus shown in Fig. 1 was therefore constructed in silica, and distillation experiments similar to those already described were carried out with reduced volumes. The initial aqueous volume in the distillation flask was reduced to 1 ml of 10 per cent. v/v sulphuric acid and the volume of methanol was reduced to 40 ml. The results obtained when known amounts of boron were distilled are shown in



Table II; they compare excellently with the calibration graph derived from Table I and show that the amounts of boron retained by the distillation assembly or lost by evaporation of the distillate are negligible. Some of the results in Table II are from experiments in which a relatively concentrated boric acid solution was used in order to keep the initial aqueous volume in the distillation flask to 1.0 ml. Further experiments showed that this volume could be increased to 2 ml, but large errors result when the aqueous volume is greater than this, *e.g.*, when 4 ml of water were added before distillation to a sample containing 10  $\mu\text{g}$  of boron and distillation was continued until the residual volume in the flask was 2 ml, the resulting optical density was 0.770.

TABLE II

## OPTICAL DENSITIES AFTER DISTILLATION OF KNOWN AMOUNTS OF BORON

Forty millilitres of methanol were used in each distillation. Optical-density measurements were made in 1-cm cells

Amount of boron added, $\mu\text{g}$	Corrected optical density after distillation	Corrected optical density without distillation	Corrected optical density in absence of methanol
2.5	0.226	—	—
3.3	0.276	—	—
	0.271	—	—
5.0	0.420	—	—
6.6	0.574	—	—
	0.561	—	—
7.5	0.649	—	—
10.0	0.865	0.874	0.866
	0.869	0.863	—

All optical-density values referred to above have been corrected for reagent blank values found by simultaneously carrying out identical manipulations with omission of the boron additions. It was found that, although blank values were variable, consistently reproducible values resulted from the use of the same batches of reagents. Most of the blank value originated from the sodium hydroxide. It was not necessary to purify the reagents, as optical-density blank values of approximately 0.025 (1-cm cell) could readily be obtained from analytical-reagent grade materials.

While this work was in progress, Spicer and Strickland<sup>17</sup> published results showing that loss of boron occurs during the evaporation of the distillate unless 33 per cent. v/v of water is added; even then, addition of glycerol is said to be necessary. Since this conclusion appeared to contradict our findings, further experiments were undertaken, the results of which are shown in Table III. The slight discrepancy between these results and those discussed pre-

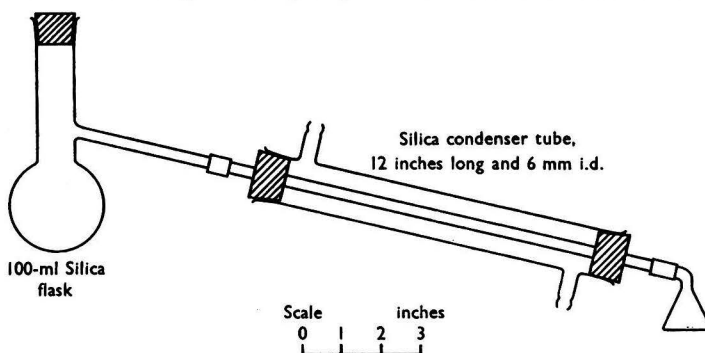

Fig. 1. Distillation apparatus

viously undoubtedly resulted from the necessity to use new batches of reagents, including curcumin, but the results in Table III confirm that losses of boron do not occur when the small-volume distillation procedure is used. Although the addition of 20 ml of water is associated with a higher boron figure (see experiments Nos. 4 and 5, Table III), the increase can be accounted for by the blank value for water. The water was taken from an ion-exchange purification unit, and the results indicate a boron content of approximately 0.02 p.p.m.

TABLE III

INFLUENCE OF WATER ON LOSS OF BORON DURING EVAPORATION OF ALKALINE SOLUTIONS CONTAINING METHANOL

Optical densities were measured in 1-cm cells

Experiment No.	Amount of 0.1 N sodium hydroxide present, ml	Amount of water present, ml	Amount of methanol present, ml	Optical density
<i>In absence of boron—</i>				
1	5	—	—	0.023, 0.023
2	5	20	—	0.048, 0.050
<i>In presence of 10 µg of boron—</i>				
3	5	—	—	0.920, 0.921
4	5	—	40	0.912, 0.918
5	5	20	40	0.949, 0.940

#### APPLICATION TO ANALYSIS OF STEEL—

Known amounts of boron were added to the initial solution of a boron-free steel; a calibration graph was constructed from the results obtained. The optical densities of the final solutions were measured in 1-cm cells and corrected for the reagent blank value; the results were as follows—

Amount of boron present, µg ..	2.5	5.0	7.5	10.0
Optical density .. .. .	0.209	0.421	0.627	0.847

These results differ slightly from those in Table II, and this is attributed to the use of different batches of reagents; it shows the importance of checking a calibration whenever new reagents are introduced.

#### METHOD

##### APPARATUS—

*Glassware*—NPL grade A glassware should be used. Reactions should, whenever possible, be carried out in boron-free glassware. Apparatus should not be cleaned with chromic acid, soap or detergents; washing with hydrochloric acid and then thoroughly rinsing with distilled water is satisfactory.

*Distillation apparatus*—The apparatus (see Fig. 1) consists of a Vitreosil 100-ml distillation flask with side-arm and a condenser constructed from a 12-inch length of silica tube of 6 mm internal diameter. The end of the condenser is fitted with a boron-free-glass funnel that dips below the level of the distillate during distillation. The components are fitted glass-to-glass, the joints being covered with best-quality rubber tubing, and the distillation flask is fitted with a good-quality cork. When new, the apparatus must be "conditioned" by carrying out two or three blank distillations.

*Platinum dishes*—The 80-ml platinum dishes used for the evaporation of methanol and the development of the boron-curcumin colour have an internal diameter of 70 mm and are 28 mm deep. Stand new dishes in boiling concentrated hydrochloric acid for a few hours before use.

*Water bath*—Temperature control and standardisation of detail are alleged to be critically important during the colour-development stage. The water bath, which was fitted with concentric cover rings, was 5 inches deep, 10 inches in diameter and electrically heated. Some rings were removed to give a centrally positioned opening 4 inches in diameter and a wire framework was used to support the platinum dishes on the water surface directly beneath this opening. The water level was adjusted until the rim of a platinum dish was about 1 inch below the plane of the rings. The temperature of the water was maintained at  $55^{\circ} \pm 1^{\circ} \text{C}$ .

*Absorptiometer*—The colour formed with curcumin has an absorption maximum at 5400 Å. The absorptiometer may be of the balanced two-cell type (selenium photocells), e.g., a Spekker instrument. For the range 0 to 10 µg of boron, use a mercury-vapour lamp, 1-cm cells, Ilford No. 605 filters and Calorex No. 503 heat-resisting filters.

## REAGENTS—

Use analytical-reagent grade materials, selected for low boron content, and freshly distilled water or water that has been freshly purified by ion exchange.

*Sulphuric acid, 20 per cent. v/v*—Cautiously add 200 ml of sulphuric acid, sp.gr. 1.84, to 700 ml of water, and stir during the addition. Cool, and dilute to 1 litre.

*Sodium hydroxide, 0.1 N*—Dissolve 4.00 g of sodium hydroxide pellets in water. Cool, and dilute to 1 litre.

*Oxalic acid reagent solution*—Dissolve 6.00 g of crystalline oxalic acid in 80 ml of water, and add 20 ml of hydrochloric acid, sp.gr. 1.18.

*Curcumin reagent solution*—Dissolve 0.100 g of curcumin in 400 ml of industrial ethanol.

*Standard boron solution*—Dissolve 0.2858 g of boric acid in water, and dilute to 1 litre in a calibrated flask.

1 ml  $\equiv$  50  $\mu$ g of boron

## PROCEDURE—

Obtain a representative sample by one of the methods described in British Standard 1837:1952: Part 1. For boron contents up to 0.02 per cent., use a 2.5-g sample; for boron contents between 0.01 and 0.05 per cent., use a 1.0-g sample; and for boron contents between 0.04 and 0.1 per cent., use a 0.5-g sample.

Transfer the sample (see Note) to a glass boiling-tube (7 inches  $\times$  1 $\frac{1}{4}$  inches), add 20 ml of 20 per cent. v/v sulphuric acid, and insert a cork fitted with an air condenser consisting of a piece of boron-free-glass tubing 24 inches in length and  $\frac{5}{16}$  inch internal diameter. After any initial reaction has subsided, place the boiling-tube in a beaker containing water at about 70° C. When dissolution appears to be complete, remove and cool the boiling-tube, and rinse the condenser with 2 ml of water. Filter the solution through an acid-washed Whatman filter-paper into a 50-ml calibrated flask, and wash the filter-paper and any residue with about 15 ml of water. (Note that filter-papers may contain small amounts of boron, and, before use, should be washed first with a solution of acid or alkali of approximately the same concentration as the solution to be filtered and then with water.)

Weigh 1.00 g of anhydrous sodium carbonate, and sprinkle a little over the residue on the filter-paper. Ignite in a small platinum dish at as low a temperature as possible, add the remainder of the sodium carbonate, and fuse at 1000° C. Cool, extract the melt with 5 ml of 20 per cent. v/v sulphuric acid, and combine the extract with the original filtrate. Dilute to the mark, and mix.

By pipette, transfer a 1-ml aliquot of the solution to the distillation flask, add 40 ml of methanol, surround the flask with a water-jacket, and heat. Collect the distillate beneath the surface of 5.0 ml of 0.1 N sodium hydroxide in a large platinum dish. Continue the distillation until the residual volume in the flask is 1 ml.

Stir the contents of the platinum dish with a platinum wire, and carefully evaporate the methanol by standing the dish on a water bath or beaker containing water that is almost boiling.

To the residue in the platinum dish add 1.0 ml of oxalic acid reagent solution and 5.0 ml of curcumin reagent solution, mix, and float the dish on a water bath maintained at 55°  $\pm$  1° C. Evaporate to dryness, and leave the dish on the water bath for a further 30 minutes after the odour of hydrochloric acid has disappeared.

Cool, and extract the residue by adding acetone - water mixture (1 + 1), a few millilitres at a time, and rubbing with a rubber-tipped stirring rod (any remaining small amounts of white material, soluble only with difficulty, can be neglected). Transfer the solution to a dry 50-ml calibrated flask, and dilute to the mark with the acetone - water mixture. Mix thoroughly, and filter through a dry coarse filter-paper into a 1-cm cell. Measure the optical density against the acetone - water mixture with an absorptiometer fitted with Ilford No. 605 filters. Deduct the blank value found by carrying out the procedure with the reagents only, and obtain the boron content of the aliquot by reference to a calibration graph.

NOTE—When the sample has a low boron content or when the amount of sample available is limited, a smaller weight than that recommended can be taken and the solution can be diluted to a lesser volume; alternatively, 4-cm cells can be used for optical-density measurements. If the latter course is adopted, the calibration conditions must be modified and particular attention must be paid to the blank value. The recommended volume of 20 per cent. v/v sulphuric acid is such that the solution after dilution contains 10 per cent. v/v of sulphuric acid (neglecting the amount used for dissolution of the sample and neutralisation of the sodium carbonate).

## PREPARATION OF CALIBRATION GRAPH—

Dissolve 10.00 g of boron-free steel in 250 ml of 20 per cent. v/v sulphuric acid, slightly evaporate, transfer to a 250-ml calibrated flask, and dilute to the mark. Place a 25-ml portion of this solution in each of five 50-ml calibrated flasks, and add, respectively, 0, 2.5, 5.0, 7.5 and 10.0 ml of standard boron solution from a burette. Dilute each solution to the mark, and mix thoroughly.

Transfer a 1-ml aliquot of each solution, equivalent to 0, 2.5, 5.0, 7.5 and 10.0  $\mu\text{g}$  of added boron, to the distillation flask, add methanol, and continue as described under "Procedure." Measure the optical density of each solution in turn against the acetone-water mixture, deduct the value for the solution containing no boron, and plot a graph of absorptiometer reading against micrograms of boron present. Note that this calibration procedure corresponds to 1-g samples of steel having a boron content up to 0.05 per cent. The amount of iron in the aliquot used for distillation is not critical within the range of sample weights taken.

## RESULTS

Tables IV and V show the results found when the proposed procedure was applied to boron-treated low-carbon and alloy steels. Each replicate determination was carried out on a separate sample, *i.e.*, not on a different aliquot from a single solution of the steel, and the results therefore indicate the over-all precision of the method. Table IV includes two results found after known amounts of boron had been added to the steel millings before acid digestion; these results show that boron is not lost during the initial dissolution.

TABLE IV  
AMOUNTS OF BORON FOUND IN LOW-CARBON BORON-TREATED STEELS

Sample No.	Boron added, %	Boron found, %
1	—	0.0043, 0.0043
2	—	0.0044, 0.0051
3	—	0.0051, 0.0051
4	—	0.0039, 0.0038, 0.0038
5	—	0.0072, 0.0074, 0.0076
3	0.0040	0.0092
4	0.0060	0.0100

TABLE V  
AMOUNTS OF BORON FOUND IN ALLOY STEELS

Sample	Boron found, %
Stainless steel (16.5 per cent. of chromium, 8 per cent. of nickel, 1 per cent. of molybdenum, 0.6 per cent. of vanadium and 0.4 per cent. of niobium) ..	0.095, 0.094
Low-chromium steel (2.7 per cent. of chromium and 0.5 per cent. of molybdenum)	0.0024, 0.0025
High-speed steel (18.5 per cent. of tungsten, 10 per cent. of cobalt, 4 per cent. of chromium, 1 per cent. of vanadium and 0.9 per cent. of molybdenum) ..	0.0138, 0.0130
Steel containing 14 per cent. of chromium .. .. .	0.0103, 0.0102
Stainless steel .. .. .	0.0116, 0.0115
High-speed steel .. .. .	0.0096, 0.0093

## CONCLUSIONS

It has been shown that the determination of boron in aqueous sodium hydroxide solutions containing methanol by colour formation with curcumin is influenced by the presence of large amounts of methanol during the evaporation stage. Spicer and Strickland's<sup>17</sup> observations on loss of boron during evaporation of the distillate were not confirmed. If the initial dissolution of the sample does not take longer than 30 minutes, a single determination can be carried out in approximately 3 hours.

One of us (J.B.) wishes to express his gratitude to members of the B.I.S.R.A. Physico-chemical Methods of Analysis Sub-Committee for useful discussion and the supply of certain steel samples.

We thank Mr. R. A. Hacking, O.B.E., Director of Research, Richard Thomas & Baldwins Limited, for permission to publish this paper.

## REFERENCES

1. Kirchgessner, W. G., and Finkelstein, N. A., *Anal. Chem.*, 1953, **25**, 1034.
2. Runge, E. F., Brooks, L. S., and Bryan, F. R., *Ibid.*, 1955, **27**, 1543.
3. Morrison, G. H., and Rupp, R. L., *Ibid.*, 1957, **29**, 892.
4. Lewis, D. T., *Analyst*, 1956, **81**, 531.
5. Shalgosky, H. I., *Ibid.*, 1957, **82**, 648.
6. White, C. E., Weissler, A., and Busker, D., *Anal. Chem.*, 1947, **19**, 802.
7. Jones, A. H., *Ibid.*, 1957, **29**, 1101.
8. Brewster, D. A., *Ibid.*, 1951, **23**, 1809.
9. Codell, M., and Norwitz, G., *Ibid.*, 1953, **25**, 1446.
10. The United Steel Companies Ltd., "Standard Methods of Analysis of Iron, Steel and Ferro-alloys," Fourth Edition, Sheffield, 1951, p. 10.
11. B.I.S.R.A. Methods of Analysis Committee, *J. Iron & Steel Inst.*, 1958, **189**, 227.
12. Chirnside, R. C., Cluley, H. J., and Proffitt, P. M. C., *Analyst*, 1957, **82**, 18.
13. Silverman, L., and Trego, K., *Anal. Chim. Acta*, 1956, **15**, 439.
14. Rynasiewicz, J., Sleeper, M. P., and Ryan, J. W., *Anal. Chem.*, 1954, **26**, 935.
15. Luke, C. L., *Ibid.*, 1955, **27**, 1150.
16. American Society for Testing Materials, "Methods of Chemical Analysis of Metals," Philadelphia, 1956, p. 132.
17. Spicer, G. S., and Strickland, J. D. H., *Anal. Chim. Acta*, 1958, **18**, 231 and 523.

Received December 18th, 1958

## The Determination of Tin in Iron and Alloy Steels

By A. I. WILLIAMS

(National Physical Laboratory, Teddington, Middlesex)

A neutron-activation method has been developed for the determination of small percentages of tin in iron and alloy steels. The method is capable of a sensitivity 100 times greater than that of the chemical procedure, and it is possible to determine accurately tin contents down to 0.0001 per cent. in alloy steels and 0.00005 per cent. in iron.

The results agree with those obtained, for samples within the range of the chemical procedure, by iodimetric titration of tin after precipitation as sulphide and hydroxide.

MANY steels contain small amounts of tin introduced from raw materials, especially scrap steels and ferrotungsten. The current interest in the effect of this impurity on the metallurgical properties of steels has necessitated an examination of the accuracy of the results found by existing chemical methods of analysis.<sup>1</sup> The chemical method is long and complicated, and the value of the results for samples having low tin contents is not known; neutron-activation analysis offered the possibility of checking the results by an independent technique.

The activation procedure adopted is no more complicated than the chemical method, and chemical separation of the radioactive tin is more rapid. A further advantage is that loss of tin during the chemical separation does not affect the accuracy of results by the activation method, as a correction is applied for percentage recovery; this is not so in the chemical method.

For alloy steels, the lower limit of the activation method is governed by the constituents of the alloy, the major interference being caused by tungsten. In most samples containing less than 10 per cent. of tungsten, the lower limit for tin is 0.0001 per cent., but, for tungsten contents above 10 per cent., the lower limit increases to 0.001 per cent., owing to the handling difficulties arising from the high activity of tungsten. For high-purity iron, the lower limit of determination of tin is 0.00005 per cent.

### EXPERIMENTAL

Irradiation of tin produces several radioactive isotopes, of which only one, tin-121, has a half-life (27 hours) suitable for use in activation analysis. The conditions chosen for irradiation were such that the yield of the long-lived isotopes, tin-113 and tin-123, was low. The sample was allowed to decay for some hours after irradiation to permit the mother isotope, tin-125 (half-life 10 minutes), to decay to antimony-125, which was later removed by scavenging during the chemical separation of the tin carrier.

The irradiated sample was dissolved in dilute hydrochloric acid in the presence of tin carrier. In order to prevent loss of tin by volatilisation of stannous chloride, the temperature was not allowed to exceed 65° C. The procedure adopted for chemical purification of the tin began with a sulphide precipitation to remove the carrier containing the active tin from the matrix. The precipitate was dissolved in hydrochloric acid, and quadrivalent tin was separated from elements forming acid-insoluble sulphides by precipitation of these sulphides from hydrofluoric acid, which formed a complex with the tin ions, probably  $\text{SnF}_6^{2-}$ .<sup>2</sup> The fluoride complex was destroyed with boric acid,  $\text{BF}_4^-$  being formed, and the tin was precipitated as stannic sulphide. The scavenge in hydrofluoric acid was repeated twice more to ensure radiochemical purity, and the final precipitate was separated by filtration, mounted and counted.

Since the initial results were erratic and  $\beta$ -emission from the tin-121 was rather weak (0.3 MeV), the possibility of self-absorption in the stannic sulphide precipitate was examined. A solution containing radioactive tin was prepared, 5-ml portions of which were added to carrier solutions containing 5, 10 and 20 mg of tin, and saturated with hydrogen sulphide. The stannic sulphide precipitates were separated on 2-cm filter-papers, washed, dried and counted under similar conditions. The precipitates were ignited, and the stannic oxide was crushed, slurried on to weighed counting trays with ethanol, dried, weighed and counted. Substantially all the tin was recovered from each solution; the results were as follows—

Amount of tin carrier taken, mg	.. ..	5	10	20
Activity of $\text{SnS}_2$ precipitate, counts per minute	..	3445	2854	2233
Activity of $\text{SnO}_2$ precipitate, counts per minute	..	1193	1173	1224

The lower activity of the stannic oxide was due to the period between counting as sulphide and oxide. Self-absorption of the low-energy  $\beta$ -particles was obviously greatly increased by thicker layers of stannic sulphide, but was negligible with thicker layers of stannic oxide. The method of preparing the tin carrier for counting was therefore modified to include ignition of the sulphide to oxide.

A high proportion of radioactive impurities in the tin carrier decreased the accuracy of the results when samples having low tin contents were analysed. To remove any activity caused by iron, a ferric hydroxide scavenge was included in the method. The stannic sulphide precipitate from the final sulphide treatment was dissolved in hydrochloric acid, 10 mg of iron carrier were added to the solution and oxidised with bromine water and scavenging was carried out in a medium containing an excess of sodium hydroxide to keep the tin in solution as stannate. This ferric hydroxide scavenge greatly reduced the level of radiochemical impurities. When it was applied to the second stannic sulphide precipitate, the level of radioactive impurities in the precipitates from a third acid-sulphide scavenge was negligible.

The preparation of a standard for comparison of the count rate against that of a known mass of tin was similar to the later stages of the separation of tin carrier from the sample matrix. Care was taken to ensure that yields of tin from the standard and sample were similar, and the aliquot of active tin in the standard was adjusted to give a count similar to that of the sample.

After separation, the recovered tin carrier was counted at 24-hour intervals in order to obtain the slope of the decay curve; this was extrapolated to zero time to give the uncorrected count for tin-121. Counting was continued for 10 days in order to determine the activity caused by long-lived isotopes of tin and radiochemical impurities. The tail of the decay curve was extrapolated to zero time and the value so obtained subtracted from the uncorrected tin-121 activity. In all determinations, the half-life of the corrected decay curve was 27 hours, which corresponds to tin-121. Examination of the stannic oxide source with a gamma-ray spectrometer showed no evidence of the presence of arsenic-76, which has a half-life similar to that of tin-121. The slope of the decay curve for the standard closely followed the pattern of that of the sample and was analysed as described. The magnitude of the decay-curve correction varied, but generally formed a fairly small proportion of the total counts, as shown by the results in Table I.

The alloying elements govern the amount of active sample that can be handled with safety, and the conditions chosen for irradiation were such that tungsten was the only element to cause handling difficulties during the early part of the radiochemical separation. No alloy-steel samples having a known tin content less than 0.021 per cent. were available for analysis; the lower limits of determination have therefore been calculated from the count rates in Table I. The results in Table I show that  $10^{-6}$  g of tin in a 1-g sample can be determined with an accuracy greater than 10 per cent. and, since 2 g of active pure iron can be

handled, the lower limit of determination is 0.00005 per cent. of tin. For alloy steels containing up to 10 per cent. of tungsten, a 1-g sample can be handled and the lower limit for tin is 0.0001 per cent., but, at tungsten contents above 10 per cent., the amount of sample must be decreased to 0.1 g and the lower limit increases to 0.001 per cent. of tin.

TABLE I  
MAGNITUDE OF DECAY-CURVE CORRECTION FOR VARIOUS ALLOY-STEEL SAMPLES

Sample No.	Tin content of sample, %	Weight of sample, g	Amount of tin present, $\mu\text{g}$	Major constituents of sample	Initial activity		Decay-curve correction, %
					Uncorrected, counts per minute	Long-lived, counts per minute	
1	0.021	0.10	21.0	{ 18 per cent. of W 4 per cent. of Cr 1 per cent. of V }	130	20	15
2	0.046	0.06	27.6	{ 22 per cent. of W 4 per cent. of Cr 12 per cent. of Co }	66	7	11
3	0.126	0.10	126.0	{ 18 per cent. of W 4 per cent. of Cr 1 per cent. of V 0.5 per cent. of Cu }	2400	230	10
4	0.017	0.20	34.0	{ 3 per cent. of W 13.5 per cent. of Cr 13.5 per cent. of Ni }	1450	310	21
5	0.017	0.20	34.0	{ 0.5 per cent. of W 14 per cent. of Cr 2.25 per cent. of C }	1800	200	11
6	0.030	0.20	60.0	{ 2 per cent. of W 18 per cent. of Cr 2 per cent. of Ni 2 per cent. of Co 2.25 per cent. of C }	2920	400	14
7	0.027	0.20	54.0	{ 20 per cent. of Cr 30 per cent. of Ni 1.5 per cent. of Ti }	960	92	10

#### METHOD

##### CARRIER SOLUTIONS—

Tin, copper, antimony, molybdenum and iron solutions containing 10 mg of metal per ml. Lanthanum solution containing 5 mg of lanthanum per ml.

##### PROCEDURE—

Irradiate the sample at pile factor 10 ( $10^{12}$  neutrons per sq. cm per second) for 6 hours, and allow to decay for 24 hours. Dissolve in a mixture of 10 ml of 5 *N* hydrochloric acid and 2 ml of tin carrier solution at a temperature not above 65° C. Oxidise with bromine water, boil, spin in a centrifuge, and discard any residue. Add ammonia solution until the precipitate formed is soluble with difficulty, saturate with hydrogen sulphide, spin in a centrifuge, and discard the solution. Dissolve the precipitate in 1 ml of hydrochloric acid, and oxidise the solution with bromine water. Dilute to 10 ml with water, spin in a centrifuge, and discard any residue. Saturate the solution with hydrogen sulphide, spin in a centrifuge, and discard the solution.

Dissolve the precipitate in 1 ml of hydrochloric acid, and add a slight excess of bromine water dropwise. Add 4 drops each of copper, antimony and molybdenum carrier solutions (bromine should still be in excess) and 0.5 ml each of sulphuric and hydrofluoric acids. Dilute to 10 ml with water, pass hydrogen sulphide into the solution for 2 to 3 minutes, spin in a centrifuge, and discard the precipitate. Add 1 ml of hydriodic acid, heat at boiling-point for 1 minute, saturate with hydrogen sulphide, spin in a centrifuge, and discard the precipitate. Add 1 ml of lanthanum carrier solution, stir, spin in a centrifuge, and discard the precipitate.

Add 10 ml of saturated boric acid solution, saturate with hydrogen sulphide, spin in a centrifuge, and discard the solution. Repeat the entire acid - sulphide scavenge step. Dissolve the precipitate in 1 ml of hydrochloric acid, and add an excess of bromine water. Dilute to 15 ml with water, and add 1 ml of iron carrier solution and an excess of 10 *N* sodium hydroxide, boil, spin in a centrifuge, and discard the precipitate. Just acidify the solution with hydrochloric acid, saturate with hydrogen sulphide, and separate the precipitate on a 2-cm Whatman No. 40 filter-paper. Wash the precipitate with water containing hydrogen sulphide, with ethanol and then with ether. Dry the precipitate and filter-paper. Place as much of the precipitate as possible in a porcelain crucible, and carefully ignite to stannic oxide. Crush the stannic oxide, transfer it, as a slurry with ethanol, to a weighed aluminium counting tray, dry at 110° C, and weigh (the recovery of tin can be calculated from the weight of stannic oxide). Mount, and count at 24-hour intervals.

Convert the activity to weight of tin by comparison with a standard sample prepared as follows. Irradiate 2 mg of pure tin at the same time as the sample. Dissolve in hydrochloric acid, and make up the solution to 100 ml. To a suitable aliquot, add sufficient tin carrier solution to give a recovery similar to that from the sample. Saturate the solution with hydrogen sulphide, separate the precipitate by filtration, and continue in the way described for the sample.

### RESULTS

By the courtesy of Mr. B. Bagshawe, Brown - Firth Research Laboratory, Sheffield, a series of alloyed samples was made available for examination by the proposed method. The major constituents of these samples are shown in Table I, and experienced analysts had determined the tin contents by the chemical method.<sup>1</sup> The results, together with those found by activation analysis, were as follows—

Sample No.	1	2	3	4	5	6	7
Tin content by chemical method, %	0.021	0.042	0.133	0.015	0.016	0.028	0.025
Tin content by proposed method, %	0.021	0.046	0.126	0.017	0.017	0.030	0.027

The work described was carried out as part of the general research programme of the National Physical Laboratory and is published by permission of the Director of the Laboratory.

### REFERENCES

1. British Standard 1121: Part 7: 1948, and Part 20: 1951.
2. U.S. Atomic Energy Commission Report A.-1721, Los Alamos, 1954.

Received December 30th, 1958

## The Determination of Oxygen in Titanium-Manganese Alloys

BY D. F. WOOD AND J. A. OLIVER

(Research Department, Imperial Chemical Industries Ltd., Metals Division, Kynoch Works, Witton, Birmingham 6)

Simple modifications to an existing semi-micro vacuum fusion method have been made; these overcome the "gettering" effect of manganese and permit oxygen to be determined satisfactorily in titanium - manganese alloys.

A 30-mg sample and about 10 mg of tin are placed in a graphite crucible containing about 5 g of platinum. The crucible is heated in an evacuated system for 10 minutes at 1500° C in order to volatilise the manganese and the temperature of the bath is then raised to 1880° C to effect quantitative conversion of oxygen to carbon monoxide.

The procedure should also be suitable for application to many other metals containing alloying amounts of manganese.

In the determination of oxygen in metals by vacuum fusion and a graphite bed,<sup>1</sup> iron bath<sup>2</sup> or platinum bath,<sup>3</sup> it is well known that difficulty may be encountered owing to the "gettering" effect of metals having high vapour pressures at elevated temperatures, e.g., aluminium, beryllium or manganese.



When a semi-micro platinum-bath method was used,<sup>4,5</sup> no difficulty was experienced in the examination of titanium - aluminium alloys, such as I.C.I. 317 (containing 5 per cent. of aluminium and 2.5 per cent. of tin) and I.C.I. 318A (containing 6 per cent. of aluminium and 4 per cent. of vanadium), presumably because the amounts of aluminium involved are insufficient to exert a significant effect. However, the method is not applicable to titanium - manganese alloys, such as I.C.I. 314C (containing 0.5 to 2.5 per cent. each of aluminium and manganese) and I.C.I. 314A (containing 4 per cent. each of aluminium and manganese). The presence of manganese in these alloys causes considerable absorption of carbon monoxide, and oxygen recoveries are invariably low and erratic. The oxygen contents of these alloys can be satisfactorily determined by bromination or chlorination,<sup>6,7</sup> but, by either of these procedures, only about two determinations can be completed in a working day compared with about twenty when the semi-micro vacuum fusion method is used.

Booth and Parker,<sup>8</sup> who used the semi-micro platinum-bath method, state that the addition of tin to the platinum bath has a noteworthy effect in suppressing volatilisation of beryllium and that, with this simple modification, oxygen can be satisfactorily determined in beryllium metal. This modification was previously used by Walter<sup>1</sup> in determining oxygen in titanium, the intention being (a) to cover any film of titanium metal formed on the crucible lid, etc., thereby preventing absorption of carbon monoxide, and (b) that the tin should act as a flux.

In order to provide a satisfactory method for determining oxygen in titanium - manganese alloys, experiments were made to study the effect of added tin on the recovery of oxygen, and, in subsequent tests, manganese was volatilised below the melting-point of platinum, at about 1500° C, before oxygen was reduced in the bath of molten platinum at 1880° C.

#### EXPERIMENTAL

Details of the semi-micro vacuum fusion procedure as applied to titanium, zirconium and certain other metals have already been described.<sup>4,5</sup> Briefly, the apparatus is evacuated and, after a satisfactory blank value has been obtained, the sample, weighing about 30 mg, is dropped into a bath of molten platinum contained in a heated graphite crucible. The evolved gases are rapidly transferred to a collecting system and analysed by a procedure involving differential pressure measurements; about twenty samples can be examined without dismantling the apparatus.

#### EFFECT OF ADDED TIN—

In preliminary experiments, the effect of adding about 10 mg of tin with each sample of 314A titanium alloy was studied; a sample of commercially pure titanium, containing 0.115 per cent. of oxygen, was examined after every second alloy sample in each series of tests. A substantial increase in oxygen recovery was observed in presence of tin, but results were erratic (see Table I).

TABLE I

#### EFFECT OF TIN ON THE DETERMINATION OF OXYGEN IN TITANIUM AND 314A ALLOY

Identical samples of 314A alloy and commercially pure titanium were used throughout.

Each vertical column represents a series of tests

Sample	Oxygen found—	
	in absence of added tin, %	in presence of 10 mg of added tin, %
Titanium .. ..	0.115*	0.12*
314A Alloy No. 1 .. ..	0.02, 0.005	0.12, 0.23
Titanium .. ..	0.08	0.12
314A Alloy No. 1 .. ..	0.005, <0.002	0.18, 0.10
Titanium .. ..	0.075	0.11
314A Alloy No. 1 .. ..	<0.002, 0.02	0.12, 0.06

\* No manganese present in the system.

Various ways of adding both sample and tin were tried, but none led to any significant improvement in the reproducibility of results for oxygen. However, it was noted that, even in the absence of tin, the recovery of oxygen from those samples of commercially pure titanium

examined immediately after manganese-containing samples was substantial but incomplete. This indicated that carbon monoxide was largely absorbed during volatilisation of manganese at high temperature and not, as previously supposed, by the film of manganese deposited on the furnace walls. The possibility of recovering oxygen quantitatively from manganese-containing samples by pre-volatilisation of the manganese at a temperature lower than that required to convert oxygen to carbon monoxide was therefore investigated.

#### DETERMINATION OF OXYGEN IN PRESENCE OF MANGANESE—

Samples of commercially pure titanium containing 0.105 per cent. of oxygen, each weighing about 30 mg, were examined both with and without the addition of 10 mg of electrolytically pure manganese. Twelve determinations were made in each series of tests (*a*) by the normal semi-micro method, and (*b*) by a modified procedure in which the sample and manganese were added to the platinum bath at 1500° C, and, after 10 minutes to allow the manganese to volatilise, the temperature was raised to 1880° C for 3 minutes. The crucible lid was raised during the entire period of these tests to allow free volatilisation of manganese. The results of these and subsequent tests on samples of 314A alloy are shown in Table II, from which it can be seen that the effect of manganese was considerably reduced and, provided that about 10 mg of tin were added with each sample, absorption of carbon monoxide by volatilised manganese was negligible. The amounts of oxygen in the added manganese and tin, 0.015 and 0.004 per cent., respectively, were determined by this modified procedure and, when possible, corrections were applied. Commercially pure standard samples of titanium and zirconium were examined in each series of tests.

Further tests were made on several samples of titanium - aluminium - manganese alloys by the modified procedure, about 10 mg of tin being added with each sample; the results were satisfactory (see Table III). Recoveries of oxygen from samples of 314A alloy were in good agreement with those by the chlorination procedure.<sup>7</sup> Results by the proposed procedure therefore support the validity of the chlorination procedure; this has not previously been possible, because of the inability to provide reliable results for oxygen in the manganese-containing samples referred to in Table III by an alternative method.

TABLE II

DETERMINATION OF OXYGEN IN PRESENCE OF MANGANESE BY VARIOUS PROCEDURES  
Identical samples of 314A alloy and commercially pure titanium were used throughout.  
Each vertical column represents a series of tests

Sample	Oxygen found by semi-micro procedure, <sup>4,5</sup> %	Oxygen found by modified semi-micro procedure—	
		in absence of added tin, %	in presence of about 10 mg of added tin, %
Titanium .. .. .	0.105*	0.095*	0.105*
Titanium + 10 mg of manganese ..	0.005	0.085	0.095
Titanium .. .. .	0.075	0.09	0.09
Titanium + 10 mg of manganese ..	0.03	0.07	0.10
Titanium .. .. .	0.075	0.08	0.085
Titanium + 10 mg of manganese ..	0.03	0.09	0.105
Titanium .. .. .	0.085	0.095	0.10
Titanium + 10 mg of manganese ..	0.005	0.08	0.10
Titanium .. .. .	0.07	0.085	0.105
Titanium + 10 mg of manganese ..	<0.002	0.08	0.105
Titanium .. .. .	0.075	0.075	0.105
Titanium + 10 mg of manganese ..	<0.002	0.065	0.105
Zirconium .. .. .	0.14*	0.13*	0.14*
314A Alloy No. 2 .. .. .	0.055	0.10	0.115
Zirconium .. .. .	0.14	0.14	0.13
314A Alloy No. 2 .. .. .	0.08	0.10	0.11
Zirconium .. .. .	0.15	0.13	0.145
314A Alloy No. 2 .. .. .	0.02	0.095	0.105
Zirconium .. .. .	0.13	0.14	0.14
314A Alloy No. 2 .. .. .	0.005	0.11	0.11

\* No manganese present in the system.

TABLE III

## AMOUNTS OF OXYGEN FOUND IN TITANIUM - ALUMINIUM - MANGANESE ALLOYS

Identical samples of commercially pure titanium were used throughout

Sample	Oxygen found by—	
	proposed procedure, %	chlorination procedure, <sup>7</sup> %
Titanium .. .. .	0.16	—
314A Alloy No. 1* .. .. .	0.18	0.18
	0.175	0.18
	0.165	0.16
	0.17	0.18
	0.175	0.17
Titanium .. .. .	0.145	—
314A Alloy No. 2* .. .. .	0.10	0.11
	0.10	0.10
	0.095	—
	0.115	—
	0.11	—
Titanium .. .. .	0.14	—
314C Alloy† .. .. .	0.10	—
	0.125	—
	0.11	—
	0.13	—
	0.125	—
Titanium .. .. .	0.14	—

\* This alloy contained 4 per cent. each of aluminium and manganese.

† This alloy contained 2 per cent each of aluminium and manganese.

## CONCLUSIONS

The semi-micro vacuum fusion procedure<sup>4,5</sup> can be satisfactorily applied to the determination of oxygen in titanium - manganese alloys, provided that the sample (30 mg), together with about 10 mg of tin, is placed in the crucible at 1500° C and that manganese is allowed to volatilise over a period of 10 minutes before the conversion of oxygen to carbon monoxide is effected at 1880° C.

About twelve determinations can be completed in 8 hours. Results by this modified procedure are within the accepted limitations of the vacuum fusion method, *i.e.*,  $\pm 0.01$  per cent. at the 0.1-per cent. level.

This modified procedure should be applicable to other metals, such as zirconium, niobium and tantalum, containing alloying amounts of manganese.

We thank Mr. W. T. Elwell, Chief Analyst, I.C.I. Metals Division, for helpful suggestions and assistance in the preparation of this paper.

## REFERENCES

1. Walter, D. I., *Anal. Chem.*, 1950, **22**, 297.
2. Sloman, H. A., Harvey, C. A., and Kubaschewski, O., *J. Inst. Metals*, 1952, **80**, 391.
3. Gregory, J. N., and Mapper, D., *Analyst*, 1955, **80**, 225 and 230.
4. Booth, E., Bryant, F. J., and Parker, A., *Ibid.*, 1957, **82**, 50.
5. "The Analysis of Titanium and Its Alloys," Imperial Chemical Industries Ltd., Second Edition, London, 1957.
6. Codell, M., and Norwitz, G., *Anal. Chem.*, 1955, **27**, 1083.
7. Elwell, W. T., and Peake, D. M., *Analyst*, 1957, **82**, 734.
8. Booth, E., and Parker, A., *Ibid.*, 1958, **83**, 241.

Received January 15th, 1959

## The Determination of Tungsten as Tristri-*n*-butylammonium 12-Tungstophosphate

BY C. C. MILLER AND D. H. THOW

(*Chemistry Department, The University, Edinburgh 9*)

12-Tungstophosphoric acid, which is used for determining various organic substances containing basic nitrogen, may itself be determined by means of some such compound. Since quantitative formation of 12-tungstophosphoric acid apparently occurs when a solution containing sodium tungstate and an excess of sodium phosphate is acidified with mineral acid, a method of determining tungsten is available.

Conditions have been established for the determination of 10 to 200 mg of tungsten as tristri-*n*-butylammonium 12-tungstophosphate in 0.25 to 2 *N* hydrochloric acid. The degree of accuracy is reasonable. Nitric or sulphuric (but not perchloric) acid may be substituted for hydrochloric acid. Considerable amounts of calcium, cobalt, copper, manganese and nickel chlorides and lead nitrate and large amounts of sodium chloride, nitrate and sulphate can be tolerated in solutions containing the corresponding acids.

WHEN tungsten is removed from mineral acid solutions as tungstic acid, its separation may be incomplete, partly because soluble complex acids, especially heteropolyacids, readily form. Cinchonine or some other organic basic substance is usually added to precipitate salts of these complex acids and to assist separation of tungstic acid; some of these substances form compounds with tungstic acid. Since mixed precipitates invariably result, they are ignited and a correction is made for contaminating elements associated with heteropolyacid formation and co-precipitated matter. The only way to obtain a reasonably pure weighable complex would apparently be to convert all the tungsten to a single heteropolyacid of definite constitution and to precipitate this acid. Simpson and his co-workers<sup>1</sup> showed that, in presence of 8 to 172 times the amount of phosphate required to form 12-tungstophosphoric acid, tungstate could be precipitated from an acidified solution by means of cinchonine, presumably as cinchonine 12-tungstophosphate, since the ignition product corresponded to  $P_2O_5 \cdot 24WO_3$ . Lambie<sup>2</sup> proved that 12-tungstoarsenate was similarly precipitated by cinchonine.

Silicon, phosphorus and arsenic are the commonest elements associated with formation of soluble heteropolyacids containing tungsten. Conversion of tungsten to tungstosilicic acid might be accompanied by objectionable production of silicic acid. Since silicon and arsenic can be easily removed from materials and phosphorus cannot, 12-tungstophosphoric acid was selected for study.

12-Tungstophosphoric acid is a well known precipitant for alkaloids and other organic substances containing basic nitrogen. Kahane and Kahane<sup>3</sup> obtained well defined anhydrous compounds at 100° C from a large number of primary, secondary and tertiary amines, arylamines, amino acids, quaternary ammonium salts and heterocyclic bases. With choline, the same product was obtained in hydrochloric acid under widely different conditions, whereas, with certain alkaloids, diamines and bases containing several nitrogen atoms in the molecule, the products varied with the conditions of precipitation. All experiments related to determination of the organic substances.

Amine complexes of cobalt, nickel, copper and chromium also form insoluble products with 12-tungstophosphoric acid; these products are of indefinite composition, because they are formed in solutions of low acidity in which partial degradation of the heteropolyacid occurs.<sup>4</sup> Amines themselves usually form precipitates at higher acidities. For maximum precipitation of simple bases there is an optimum acidity, usually from pH 3 to 1, but, for a series of homologues, this optimum acidity becomes less marked as the molecular weight increases. For alkaloids, maximum precipitation occurs at an increasingly higher acidity as molecular weight increases. For cinchonine, 0.5 to 1 *N* acid is best.<sup>5</sup>

We have studied the precipitation of tungstophosphoric acid from mineral acid solution with a number of organic bases and particularly with tri-*n*-butylamine, for which conditions for forming a weighable complex have been established.

## EXPERIMENTAL

## PRELIMINARY TESTS ON PRECIPITATION OF TUNGSTOPHOSPHATE—

Ten per cent. solutions of various organic basic substances and quaternary ammonium salts, which were not specially purified, were prepared in dilute hydrochloric acid or in water. A few drops of each solution were added, with stirring, to 2 ml of a hot solution containing 2 mg of sodium tungstate, 0.8 mg of disodium hydrogen orthophosphate and sufficient hydrochloric acid to make the solution 0.1 or 1.5 *N*. Each precipitate was spun in a centrifuge, and a portion of the supernatant solution was tested for tungsten with toluene-3:4-dithiol. Promising reagents were quinoline, isoquinoline, 2:4-dimethylquinoline, 8-hydroxy- and 5:7-dibromo-8-hydroxyquinoline, benzylphenyldimethylammonium chloride, cetyltrimethylammonium chloride, 4:4'-tetramethyldiaminobenzophenone, tri-*n*-butylamine and cinchonine. The degree of precipitation with diethylenetriamine, triethylenetetramine, triethanolamine, tetraethylammonium hydroxide, piperazine hydrate and 2-chloroquinoline was unsatisfactory. With some of the former group of substances, quantitative experiments were similarly made on larger amounts of solutions approximately *N* in hydrochloric acid and containing 200 mg of sodium tungstate. Precipitates were collected, dried at 105° C and weighed. Portions were then ignited to tungstophosphoric oxide and weighed. The ratio of the molecular weights calculated for the products obtained at 105° C to those expected for

TABLE I

RATIOS OF MOLECULAR WEIGHTS CALCULATED FROM EXPERIMENTAL RESULTS TO THOSE EXPECTED FOR VARIOUS COMPLEXES

Reagent	Formula for anhydrous complex	Molecular weight from experiment
		Molecular weight expected
Quinoline .. .. .	(C <sub>9</sub> H <sub>7</sub> N·H) <sub>2</sub> PW <sub>12</sub> O <sub>40</sub>	1.02
Cetyltrimethylammonium chloride	(C <sub>17</sub> H <sub>43</sub> N) <sub>3</sub> PW <sub>12</sub> O <sub>40</sub>	1.06
5:7-Dibromo-8-hydroxyquinoline..	(C <sub>9</sub> H <sub>5</sub> Br <sub>2</sub> ON·H) <sub>2</sub> PW <sub>12</sub> O <sub>40</sub>	1.05 ± 0.02
Cinchonine .. .. .	(C <sub>19</sub> H <sub>23</sub> ON <sub>2</sub> ·H <sub>2</sub> ) <sub>2</sub> (PW <sub>12</sub> O <sub>40</sub> ) <sub>2</sub>	1.03
8-Hydroxyquinoline .. .. .	(C <sub>9</sub> H <sub>7</sub> ON·H) <sub>2</sub> PW <sub>12</sub> O <sub>40</sub>	1.01
2:4-Dimethylquinoline .. .. .	(C <sub>11</sub> H <sub>11</sub> N·H) <sub>2</sub> PW <sub>12</sub> O <sub>40</sub>	1.01
Tri- <i>n</i> -butylamine .. .. .	[(C <sub>4</sub> H <sub>9</sub> ) <sub>3</sub> N·H] <sub>2</sub> PW <sub>12</sub> O <sub>40</sub>	1.04

certain anhydrous complexes are shown in Table I; these results suggest that definite complexes are formed. Solubility losses were about 1 per cent. for all reagents except quinoline, for which the loss was greater. Cetyltrimethylammonium chloride formed extremely slow-filtering precipitates, and 5:7-dibromo-8-hydroxyquinoline formed sticky precipitates that changed markedly in appearance when set aside. The complexes formed with 8-hydroxyquinoline and cinchonine absorbed moisture. The last four reagents in Table I were also applied to the determination of 5-mg amounts of tungsten in 100 ml of solution; yields were promising. Tri-*n*-butylamine, which formed easily filterable precipitates that did not adhere to glassware, was selected for further experiments, in preference to the much more expensive 2:4-dimethylquinoline.

PRECIPITATION OF TUNGSTOPHOSPHATE BY PURIFIED TRI-*n*-BUTYLAMINE—

A few experiments were made to determine the degree of completeness of precipitation and the composition of precipitates. To 240 ml of solution containing 0.5 g of tungsten, as sodium tungstate, and 0.32 g of disodium hydrogen orthophosphate were added 10 to 11 ml of 6 *N* hydrochloric acid. To the boiling solution, 25 ml of a 2 per cent. w/v (3 per cent. in experiment No. 3, see Table II) solution of tri-*n*-butylamine in 0.25 *N* hydrochloric acid were added dropwise, with stirring. The mixture was digested at its boiling-point for 15 minutes and cooled in an ice-water mixture for 1 hour or left overnight. The precipitate was then collected in a sintered-porcelain crucible and washed, first with an ice-cold 0.5 per cent. solution of tri-*n*-butylamine in 0.25 *N* hydrochloric acid and finally with a little water. Heating was effected as indicated in Table II, in which all figures have been adjusted to be equivalent to exactly 0.5 g of tungsten. Precipitates were transferred to platinum crucibles for ignition in order to avoid permanent contamination of filter-crucibles.

The results in Table II indicate essentially complete precipitation of tungsten and ultimate formation of 12-tungstophosphoric oxide. Precipitates heated at 105° to 150° C give erratic results, and a temperature above 200° C is necessary for removing a variable amount of

TABLE II

EFFECT OF HEATING TRI-*n*-BUTYLAMMONIUM TUNGSTOPHOSPHATE DERIVED FROM 500 mg OF TUNGSTEN500 mg of tungsten  $\equiv$  779 mg of  $[(C_4H_9)_3N \cdot H]_3PW_{12}O_{40} \equiv$  647 mg of  $P_2O_5 \cdot 24WO_3$ 

Experiment No.	Weight of precipitate after heating at—					Amount of tungsten found in filtrate, mg
	105° C for 1 hour, mg	150° C for 45 minutes mg	200° C for 1 hour, mg	200° C for 3 hours, mg	800° C for 1 hour, mg	
<i>Filtration after 1 hour—</i>						
1	783	782	777, 777	777	647	0.5
2	784	783	778, 778	778	647	0.1
3	807	—	784, 780	778	648	n.d.
<i>Filtration after 18 hours—</i>						
4	797	796	782, 778	777	645	0.1
5	—	—	779,* 778*	777†	—	0.1
6	—	—	781,* 779*	776†	—	0.8

\* Heated at 215° C for 1 hour.

† Heated at 215° C for 18 hours.

impurity, supposedly a tri-*n*-butylammonium salt. In experiments Nos. 5 and 6, precipitates were heated immediately at 215° C to expedite removal of the impurity, but removal of the last traces was still slow and there was probably slight decomposition of the precipitate; this became noticeable at 250° C, the loss being 2 mg per hour.

Portions of the precipitate formed in experiment No. 3, in which the product obtained after heating at 105° C was significantly heavier, were utilised for several tests. A 123-mg sample was heated in a Stanton recording thermobalance, and the results are shown in Fig. 1. For weight constancy, a temperature between 195° and 220° C was indicated. Heating for 2 hours at 210° C was adopted in subsequent experiments. Although the initially white precipitates might become slightly discoloured or blackened at the edges, no important weight change appeared to be involved. In other 60-mg portions of precipitate, 1.40 per cent. of nitrogen was found by the Kjeldahl procedure under conditions in which tri-*n*-butylamine gave theoretical results for nitrogen.  $[(C_4H_9)_3N \cdot H]_3PW_{12}O_{40}$  contains 1.22 per cent. of nitrogen. The excess of nitrogen is equivalent to 24 mg of the amine or 29 mg of its hydrochloride per 500 mg of tungsten; the recorded weight loss of the precipitate between 105° and 200° C is of this order.

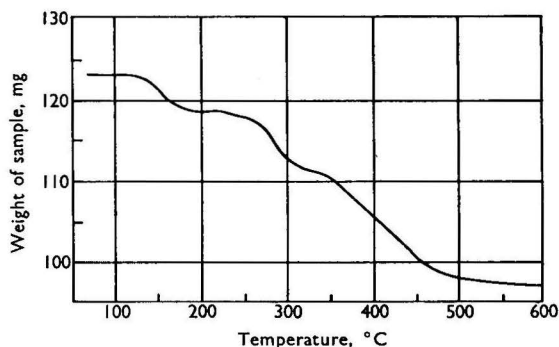
Fig. 1. Effect of heating a sample of tri-*n*-butylammonium tungstophosphate in a thermobalance

Amine complexes that had been cooled over calcium chloride absorbed 0.25 per cent. of water when exposed to an atmosphere of 50 per cent. humidity. Crucibles should therefore be cooled in a desiccator. Insufficient attention was paid to this matter in the experiments just described.

#### FORMATION OF 12-TUNGSTOPHOSPHORIC ACID FROM SODIUM TUNGSTATE AND PHOSPHATE—

To show that 12-tungstophosphoric acid was indeed formed in the experiments described above, the amounts of tungsten in 25-ml portions of a filtered solution of analytical-reagent

grade 12-tungstophosphoric acid, containing approximately 0.8 per cent. of tungsten, were determined as the tri-*n*-butylammonium complex in presence of 0.25 *N* hydrochloric acid, both with and without extra phosphate added as orthophosphoric acid. In further portions, the complex acid was fully degraded (pH >9) with a small excess of sodium hydroxide solution, more phosphate, as disodium hydrogen orthophosphate, was added, if desired, the solution was acidified with sufficient hydrochloric acid to make the free acid 0.25 *N* and tungsten was precipitated as before. The results are shown in Table III, from which it can be seen that no marked difference exists between determinations made directly with 12-tungstophosphoric acid and those made after degradation and re-formation of tungstophosphoric acid when additional phosphate was added after degradation. As we did not need to use a minimum amount, we did not examine the effect of less than a ten-fold excess. The filtrate in experiment No. 3 contained 0.3 mg of tungsten; the filtrates in the other experiments each contained 0.2 mg of tungsten.

TABLE III

WEIGHTS OF TRI-*n*-BUTYLAMMONIUM TUNGSTOPHOSPHATE OBTAINED FROM SIMILAR PORTIONS OF 12-TUNGSTOPHOSPHORIC ACID SOLUTION

Approximately 200 mg of tungsten  $\equiv$  8.5 mg of phosphate (as PO<sub>4</sub>)

Experiment No.	Amount of phosphate present, as PO <sub>4</sub> , mg	Amount of precipitate obtained, mg	Conditions
1	8.5	311.3	Direct precipitation
2	85	311.7	
3	8.5	312.7	Solution made alkaline and slowly re-acidified
4	85	311.4	
5	85	311.3	Solution made alkaline and rapidly re-acidified

The precipitates from experiments Nos. 1 and 2 were ignited and fused with sodium carbonate, and phosphate in the fusion products was determined spectrophotometrically as vanadomolybdophosphate<sup>6</sup> at 440 m $\mu$ . Tungstate influenced the absorption, but was compensated for by inclusion in the standard solutions. The amount of phosphorus found in 311 mg of precipitate was  $2.89 \pm 0.01$  mg, and the same amounts of precipitate obtained from tungstate plus phosphate gave 2.90 mg. The required amount is 2.81 mg.

## METHOD

## REAGENTS—

As far as possible, use materials of recognised analytical-reagent grade. Purify tri-*n*-butylamine by fractional distillation twice at atmospheric pressure and collection of the fraction boiling between 206° and 209° C at a pressure of 760 mm, or, better, purify by vacuum distillation and collection of the colourless liquid boiling between 83° and 88° C at a pressure of 10 mm.

*Tri-n-butylammonium chloride solution*—Prepare daily a 2 per cent. w/v solution of tri-*n*-butylamine by shaking the purified amine with just enough diluted hydrochloric acid to neutralise it.

*Tri-n-butylamine wash solution*—Prepare a 0.1 per cent. w/v solution of the purified amine in 0.1 *N* hydrochloric acid.

*Sodium tungstate solution*—Prepare a standard solution from anhydrous sodium tungstate, the tungsten content of which has been checked. We used Specpure tungsten trioxide (99.99 per cent. pure) as reference standard. Weighed portions of ignited material were converted to sodium tungstate by fusion with sodium carbonate. In the solutions therefrom and in solutions prepared from weighed amounts of sodium tungstate, tungsten was determined under identical conditions.

## PROCEDURE—

To about 50 ml of solution, containing 10 to 200 mg of tungsten, as sodium tungstate, and at least 85 mg of phosphate (PO<sub>4</sub>), as disodium hydrogen orthophosphate, gradually add 6 *N* hydrochloric acid (this concentration is not critical) with stirring until the pH is about 2, and then add 4 ml of acid in excess. Dilute to 100 ml with water. Heat the solution almost to its boiling-point, add 10 ml of 2 per cent. w/v tri-*n*-butylammonium chloride solution, with

stirring, and continue to heat for 15 minutes or until the precipitate has coagulated. Cool in an ice-water mixture if filtration has to be carried out after 1 hour, or set aside overnight in a cool place. Filter the solution through a fine-pore sintered-porcelain or glass crucible, and wash the precipitate with a minimum amount of cold tri-*n*-butylamine wash solution and then with a little cold water. Heat the precipitate for 2 hours at 210° C, cool in a desiccator, and weigh.

## DISCUSSION OF THE METHOD

## EFFECT OF DIFFERENT CONDITIONS—

The proposed method and modifications thereof were applied to portions of standard tungstate solution in order to ascertain the extent to which various factors could be altered without adverse effect on the recovery of tungsten. Phosphate in excess of 85 mg was added, as orthophosphoric acid, to acidified solutions. The results are shown in Table IV, in which all figures have been slightly modified to correspond to exactly 200, 50 or 10 mg of tungsten.

TABLE IV

EFFECT OF DIFFERENT CONDITIONS ON DETERMINATION OF TUNGSTOPHOSPHATE WITH TRI-*n*-BUTYLAMINE

200 mg of tungsten  $\equiv$  8.5 mg of phosphate (as PO<sub>4</sub>)  $\equiv$  50 mg of tri-*n*-butylamine

Amount of tungsten taken, mg	Amount of phosphate taken, as PO <sub>4</sub> , mg	Hydrochloric acid present, N	Amount of tri- <i>n</i> -butylamine used, g	Weight of precipitate obtained—		Amount of tungsten found, mg
				at 105° C, mg	at 210° C, mg	
<i>Solution set aside for 1 hour before filtration—</i>						
200.0	85	0.25	0.2	314.0, 313.7	311.3, 311.1	199.9, 199.8
10.0	85	0.25	0.2	15.9, 15.8	15.4, 15.4	9.9, 9.9
200.0	85	0.25	0.2	314.1	309.8	198.9
		0.25	0.2	312.7	309.8	198.9
		0.25	0.1	310.8	310.4	199.3
		0.25	2.5	325.0	311.6	200.1
		1	0.1	313.8	310.4	199.3
		1	0.2	320.9	311.7	200.1
		1	2.5	324.4	310.8	199.6
		2	0.2	316.2	306.7	196.9
		2	2.5	—	308.7	198.2
		1	0.2	14.0	13.6	8.7
10.0	85	1	2.5	—	14.0	9.0
		2	0.2	12.8	12.4	8.0
		2	0.2	—	—	—
<i>Solution set aside overnight before filtration—</i>						
10.0	850	2	0.2	—	15.4	9.9
50.0	850	2	0.2	—	77.4	49.7
		2	0.2	—	77.1	49.5
200.0	850	1	0.2	325.5	311.3	199.9
		1	0.2	326.1	311.6	200.1
		2	0.2	324.7	310.2	199.2

Except at low acidity, recovery of 10 mg of tungsten is not quantitative from solutions that have been set aside for only 1 hour before filtration, even if a large excess of precipitant has been added. For 200 mg of tungsten in presence of 85 mg of phosphate, the maximum permissible acidity is 1 N. Precipitates set aside overnight before filtration give acceptable results for 10 to 200 mg of tungsten in up to about 2 N acid, even in presence of much more phosphate. An increase in the amount of tri-*n*-butylamine has comparatively little influence on recovery of tungsten, but contamination of precipitates is increased. Heating at 210° C reduces all weights to an acceptable level. Greater initial contamination of precipitates also occurs at higher acidities. In general, when larger amounts of phosphate are present and acidity is high, precipitates containing large or small amounts of tungsten should be set aside overnight before filtration. The amount of tri-*n*-butylamine suitable for precipitation of 10 to 200 mg of tungsten in 100 ml of solution is 0.2 g.

## EFFECT OF OTHER ACIDS AND VARIOUS SALTS—

The results of experiments in nitric or sulphuric acid, precipitant and wash solution being prepared in the same acid, are shown in Table V. Sulphuric acid has a slight hindering effect



on precipitation, and precipitates must be set aside overnight for satisfactory recovery of tungsten. Nitric acid exerts no hindering effect, but the precipitates from 200 mg of tungsten had a brownish colour, which was associated with a small positive error.

TABLE V  
EFFECT OF NITRIC AND SULPHURIC ACIDS ON DETERMINATION OF TUNGSTEN  
Solutions were set aside for 18 hours before filtration

Amount of tungsten taken, mg	Amount of phosphate used, as PO <sub>4</sub> , mg	Amount of acid present, <i>N</i>	Amount of sodium salt present, g	Amount of tungsten found—	
				in sulphuric acid, mg	in nitric acid, mg
10.0	85	0.25	—	9.9	10.0*
	850	1	—	9.9	9.8
200.0	85	0.25	—	197.6*	200.3*
	85	1	—	199.8	—
	850	1	—	199.6	200.4
	850	1	5	199.6	200.0

\* Filtration after 1 hour.

Less than 0.1 mg of tungsten was detected in filtrates. Sodium salts have no significant effect.

Large amounts of perchloric acid cannot be used because it forms a precipitate with the amine. With 200 mg of tungsten in 0.2 *N* perchloric acid and addition of amine hydrochloride, the error in the weight of precipitate obtained after the solution had been set aside for 1 hour before filtration was +0.9 mg.

The effect of various metallic chlorides (except for lead, when lead nitrate and nitric acid were used) on the precipitation of tungstophosphate is shown in Table VI. In all experiments, 850 mg of phosphate were present and the various salts were added to acidified solutions.

TABLE VI  
EFFECT OF VARIOUS ELEMENTS ON DETERMINATION OF 200.0 mg OF TUNGSTEN

Element	Amount of element added, mg	Amount of tungsten found by—		Amount of tungsten found in filtrate after—	
		procedure A,* mg	procedure B,† mg	procedure A,* mg	procedure B,† mg
Calcium ..	700	200.4	199.8	0.2	0.8
Chromium <sup>III</sup> ..	700	187.1	193.7	>6	>3
	100	198.3	—	1.5	—
	25	198.6	—	0.2	—
Cobalt <sup>II</sup> ..	700	200.4	200.6	0.3	0.2
Copper <sup>II</sup> ..	700	200.2	201.2	0.6	<0.1
Lead (HNO <sub>3</sub> ) ..	700	200.7	197.6	n.d.	n.d.
Manganese <sup>II</sup> ..	700	200.3	199.9	<0.2	0.1
Nickel ..	700	200.0	200.2	<0.2	<0.2
Sodium ..	2000	199.8	—	<0.2	—

\* Precipitation from *N* hydrochloric acid; set aside overnight before filtration.

† Precipitation from 0.25 *N* hydrochloric acid; filtration after 1 hour.

A large amount of sodium chloride has no adverse effect. Of the other elements tested, only chromium causes serious error under the conditions of procedure A, despite the large amounts added; somewhat smaller amounts would probably be without influence. Chromium hinders precipitation of tungsten and, when a large amount is present, grossly contaminates the precipitate, which is yellow in colour. To a much lesser extent, copper and cobalt probably exert comparable effects.

Of other elements examined, molybdenum as molybdophosphate forms precipitates with the amine under the various conditions used for tungstophosphate. Alone, vanadium as vanadophosphate does not react, but, in conjunction with tungstate, it forms orange precipitates, presumably of tri-*n*-butylammonium tungstovanadophosphate. A study of the behaviour of iron, which is complex, has not yet been completed.

We are indebted to Dr. R. A. Chalmers, Aberdeen University, for recording the thermal behaviour of tris(*n*-butylammonium tungstophosphate, and to the Gemec Chemicals Company, London, for supplying a sample of diethylenetriamine.

## REFERENCES

1. Simpson, S. G., Schumb, W. C., and Sieminski, M. A., *Ind. Eng. Chem., Anal. Ed.*, 1938, **10**, 243.
2. Lambie, D. A., *Analyst*, 1949, **74**, 405.
3. Kahane, E., and Kahane, M., *Bull. Soc. Chim. France*, 1931, [4] **49**, 557; *Ibid.*, *Mémoires*, 1936, [5] **3**, 621.
4. Jean, M., *Ann. Chim.*, 1948, **3**, 470.
5. ———, *Ibid.*, 1948, **3**, 499.
6. Center, E. J., and Willard, H. H., *Ind. Eng. Chem., Anal. Ed.*, 1942, **14**, 287.

Received January 26th, 1959

## Raman Spectra in Spectrofluorimetry

By C. A. PARKER

(Admiralty Materials Laboratory, Holton Heath, Poole, Dorset)

The effect of the Raman spectrum of the solvent on the measurement of the fluorescence of very dilute solutions has been investigated. The Raman spectra of five commonly used solvents have been recorded with a spectrofluorimeter. Solvents such as water, ethanol or cyclohexane, which contain hydrogen atoms, show an intense Raman band at a wave-number approximately 0.3 reciprocal microns lower than that of the exciting light. This can produce an appreciable distortion of the fluorescence spectrum of a strongly fluorescent substance at a concentration as high as 0.1  $\mu\text{g}$  per ml. For a weakly fluorescent substance the effect is correspondingly greater. In filter fluorimetry at high sensitivity, the Raman bands can give rise to an increase in the blank if secondary filters are not properly chosen.

THE development of sensitive fluorimeters has now reached the point at which the limit of sensitivity is set not by the minimum intensity of light detectable by the equipment but by the magnitude of the blank obtained in any particular determination. This blank includes not only fluorescence caused by traces of impurities in the solutions being measured but also contributions from various instrumental defects. In filter fluorimetry it may include a blank due to filter inefficiency, *i.e.*, the primary filter system may pass a small proportion of the radiation from the source at a wavelength also passed by the secondary filter system. It may also include a contribution due to fluorescence of the secondary filters by exciting light scattered from the solution or cuvette. Such errors can be avoided by the use of efficient monochromators for isolating the exciting and the fluorescent light. A further source of unwanted fluorescence is the cuvette itself. This interference can be minimised by careful design of the geometry of the cell compartment so that the parts of the cuvette irradiated by the exciting beam are not "visible" to the detector, but it is difficult to reject completely all the fluorescent light from the cuvette, and for work at high sensitivity it is necessary to choose for the construction of the cuvette a material having the minimum fluorescence (*e.g.*, synthetic silica instead of fused quartz).

All the above-mentioned effects can in theory be reduced to negligible proportions by suitable design of equipment, purification of solvents and choice of suitable materials for cuvettes. There still remains one effect that cannot be overcome in this way, namely, Raman emission from the pure solvent. This appears at longer wavelengths than that of the exciting light and in some circumstances can cause serious interference when very weakly fluorescent solutions have to be measured. Some experiments were therefore carried out to determine the magnitude of the effect in various circumstances.

## APPARATUS

The spectrofluorimeter used had been designed to provide considerably greater sensitivity, resolution and versatility than that previously described.<sup>1</sup> The detector was an E.M.I. 13-stage photomultiplier (type 6256B) and was operated from a commercial 2000-volt supply;

the voltage could be varied continuously, so as to provide the desired photomultiplier sensitivity. The exciting light was chopped at 800 cycles, and the output from the photomultiplier was amplified by a commercial 800-cycle tuned amplifier, the amplified output being passed to one arm of a ratio recorder. The beam of exciting light passed through a clear fused-quartz plate, which served to deflect a small proportion of the beam on to a fluorescent screen-monitor,<sup>2</sup> the amplified output from the monitoring photomultiplier tube being passed to the other arm of the ratio recorder, which thus recorded the ratio of fluorescence intensity to intensity of exciting light. The purpose of the monitor was two-fold; firstly, it served to compensate for fluctuations in the intensity of the source, and secondly, in the measurement of fluorescence excitation spectra, it automatically compensated for variation in the quantum output of the exciting source with wavelength, so that the true excitation spectrum was recorded directly.<sup>2</sup>

In general, the use of monochromators to disperse both exciting and fluorescent light leads to greatly reduced over-all sensitivity, owing to the large amount of light lost during this double dispersion. However, it was found that, by using the highly sensitive 13-stage photomultiplier and quartz-prism monochromators of moderate aperture (Hilger D247), sufficient sensitivity could be obtained to record the main features of the Raman spectra.

A schematic diagram of the apparatus has been published previously,<sup>2</sup> and only one or two points of particular interest need be described here. A synthetic-silica cuvette was used (1 cm  $\times$  1 cm optical depth and 5 cm tall). When the full slit height was used, measurements could be made on 2 ml of liquid, or less if a smaller slit height (and hence lower intensity) was accepted. A 1-kW high-pressure compact-source mercury lamp was used for measuring fluorescence emission and Raman spectra and a Siemen's xenon arc lamp, type XC, for measuring excitation spectra. With both lamps, the light was focused on the entrance slit of the exciting monochromator by means of a small short-focus quartz lens. For isolating the mercury lines, comparatively wide slits were used (*i.e.*, 0.5 mm at 248, 313 and 365  $m\mu$  and 0.25 mm at 436  $m\mu$ ), the slits of the fluorescence monochromator being kept at 0.25 mm. For recording excitation spectra, the slits of the fluorescence monochromator were opened to 1 mm (the half-band width at 400  $m\mu$  was approximately 0.1  $\mu^{-1}$ ) and the slits of the exciting monochromator were then varied to keep the light intensity approximately constant (the half-band width varied generally from 0.02 at low wave-numbers to 0.08  $\mu^{-1}$ ). The light intensity available (einstein per minute  $\times 10^9$ ) when the mercury lamp was used, as measured by the ferrioxalate actinometer,<sup>3,4</sup> was approximately as follows—2 (248  $m\mu$ ), 25 (313  $m\mu$ ), 100 (365  $m\mu$ ) and 50 (436  $m\mu$ ). The light intensity available from the xenon lamp was about  $1 \times 10^{-9}$  einstein per minute.

#### RAMAN SPECTRA OF SOLVENTS

When a substance is illuminated by light that it does not absorb, a small proportion of the light is scattered in all directions at unchanged frequency. A much smaller proportion is scattered at changed frequency, the frequency differences, as compared with that of the exciting light, corresponding to rotational or nuclear vibrational frequencies of the molecule. These frequency shifts are therefore constant for a given substance and independent of the exciting frequency. Most of the Raman emission occurs at frequencies lower than that of the exciting light and can thus interfere with measurement of the fluorescence spectrum of a solute if this is very weak.

When illuminated by monochromatic light, most liquids give rise to a Raman spectrum consisting of both lines and bands,<sup>5</sup> but, at the comparatively low resolution used in spectrofluorimeters, only the most prominent bands are likely to give rise to interference. Thus water produces a prominent Raman band corresponding to a shift in frequency of 0.32 to 0.36  $\mu^{-1}$ , which appears as a sharp peak in the fluorescence spectrum (see Fig. 1). To determine the relative magnitudes and positions of the most prominent bands, recordings were made with five representative solvents (water, ethanol, cyclohexane, chloroform and carbon tetrachloride), four different mercury lines being used for excitation (248, 313, 365 and 436  $m\mu$ ). No special precautions were taken to remove the last traces of fluorescent impurities from solvents (water and ethanol were doubly distilled, and the others were commercial spectroscopically pure materials). The results obtained at 313 and 365  $m\mu$  are shown in Fig. 1, the Raman peaks being distinguished from fluorescence by the fact that their positions altered with the frequency of the exciting light in a manner such that the frequency shift remained constant.

Each most prominent band (or in some instances the two most prominent bands) is recorded in Table I, from which it can be seen that, within experimental error, the frequency shifts are independent of the frequency of the exciting light.

It can also be seen from Table I that all solvents containing hydrogen atoms show a band in the region of  $0.3 \mu^{-1}$ , that of ethanol having a subsidiary inflexion on the low wave-number

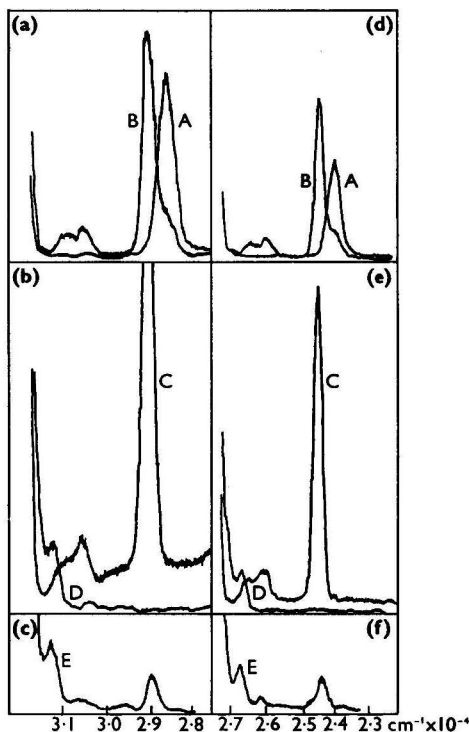

Fig. 1. Recordings of Raman bands excited by (a), (b) and (c),  $313\text{-m}\mu$  light, (d), (e) and (f),  $365\text{-m}\mu$  light: curve A, water; curve B, ethanol; curve C, *cyclohexane*; curve D, carbon tetrachloride; curve E, chloroform

side, possibly owing to the presence of both CH and OH bonds in this substance. *cyclohexane* shows the narrowest and most intense band, in almost exactly the same position as the ethanol band. Both ethanol and *cyclohexane* also show a subsidiary double peak corresponding to a smaller frequency shift (*i.e.*, appearing in Fig. 1 at higher wave-numbers).

TABLE I  
RAMAN BANDS OBSERVED IN SELECTED SOLVENTS  
Each recorded value is the mean of several determinations

Solvent	Frequency shifts with exciting light at—				Mean frequency shift, $\mu^{-1}$
	$248 \text{ m}\mu$ , $\mu^{-1}$	$313 \text{ m}\mu$ , $\mu^{-1}$	$365 \text{ m}\mu$ , $\mu^{-1}$	$436 \text{ m}\mu$ , $\mu^{-1}$	
Water .. .. .	0.339	0.339	0.340	0.335	0.338
Ethanol .. .. .	{ 0.292 0.143 0.287	{ 0.292 0.143 0.287	{ 0.293 0.141 0.291	{ 0.290 0.134 0.285	{ 0.292 0.140 0.288
<i>cyclohexane</i> .. .. .	{ 0.137	{ 0.138	{ 0.135	{ 0.132	{ 0.136
Carbon tetrachloride .. .. .	—	0.073	0.079	0.071	0.074
Chloroform .. .. .	{ —	{ 0.073	{ 0.073	{ 0.065	{ 0.070
	{ —	{ 0.301	{ 0.301	{ 0.304	{ 0.302

The position of the more intense of these two peaks is also indicated in Table I. Carbon tetrachloride shows no significant bands at large frequency shifts, owing to the absence of hydrogen atoms. The main band is close to the scattered light, the separation being only  $0.07 \mu^{-1}$ . A similar band is shown by chloroform, which also has a band in the region of  $0.3 \mu^{-1}$ , although this is less intense than the main bands of the other solvents containing hydrogen atoms.

#### INTERFERENCE WITH FLUORESCENCE EMISSION SPECTRA

Table II shows, for each solvent, the position of the main Raman band that would be observed when various mercury lines were used for the excitation of fluorescence emission spectra. From this Table can be judged the likely interference in any particular application.

TABLE II

POSITIONS OF MOST PROMINENT RAMAN BANDS CORRESPONDING TO VARIOUS MERCURY LINES

Solvent	Wavelength of main Raman band produced by exciting light at—				
	248 m $\mu$ ,	313 m $\mu$ ,	365 m $\mu$ ,	405 m $\mu$ ,	436 m $\mu$ ,
	m $\mu$	m $\mu$	m $\mu$	m $\mu$	m $\mu$
Water .. .. .	271	350	416	469	511
Ethanol .. .. .	267	344	409	459	500
<i>cyclo</i> Hexane .. .. .	267	344	408	458	499
Carbon tetrachloride .. .. .	—	320	375	418	450
Chloroform .. .. .	—	346	410	461	502

The main band of carbon tetrachloride is at a wavelength so close to that of the exciting light that it is unlikely to interfere with the fluorescence spectrum, and, from this point of view, carbon tetrachloride is the most satisfactory solvent to use in high-sensitivity spectrofluorimetry (at least at the longer wavelengths above its cut-off). The high-frequency band of

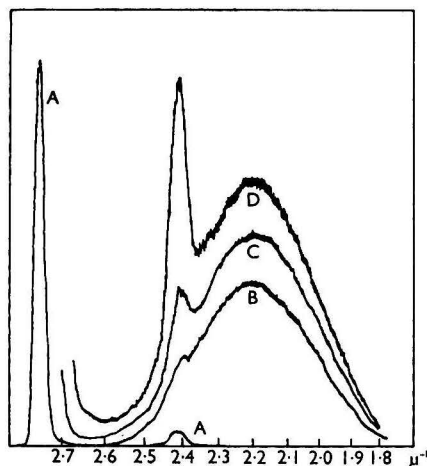

Fig. 2. Fluorescence emission spectrum of quinine sulphate in 0.1 *N* sulphuric acid excited by 365-m $\mu$  light (showing interference by Raman band of water): curve A, water alone at low sensitivity; curve B, 0.1  $\mu$ g per ml at same sensitivity; curve C, 0.033  $\mu$ g per ml at increased sensitivity; curve D, 0.01  $\mu$ g per ml at still greater sensitivity

chloroform is less intense than those of the other solvents, and it is thus likely to give rise to less interference than water, ethanol or *cyclo*hexane. The magnitude of interference by the Raman spectrum of water can be judged from Fig. 2, which shows the fluorescence spectra of three dilute solutions of quinine sulphate in 0.1 *N* sulphuric acid, the mercury line at 365 m $\mu$  being used for excitation. At this excitation wavelength, the main Raman band of water occurs at 416 m $\mu$  and thus overlaps the edge of the fluorescence spectrum of quinine. At

the low sensitivity used in recording the spectrum of the most concentrated solution ( $0.1 \mu\text{g}$  per ml, curve B), the scattered-light peak at  $365 \text{ m}\mu$  was still on scale and the Raman band of the pure solvent was small (curve A). When the sensitivity was increased to record the spectra of the more dilute solutions, the Raman band became increasingly prominent (curves C and D). Its integrated area corresponds to about  $0.001 \mu\text{g}$  of quinine sulphate per ml.

The Raman band is much narrower than the fluorescence band of quinine sulphate and is thus prominent when fairly narrow spectrometer slits are used (as in Fig. 2). If, however, a spectrofluorimeter of somewhat lower sensitivity were used to record the fluorescence emission spectrum of an extremely dilute solution of quinine sulphate, it would be necessary to open the slits of the spectrometer to obtain sufficient light (the corresponding reduction in resolving

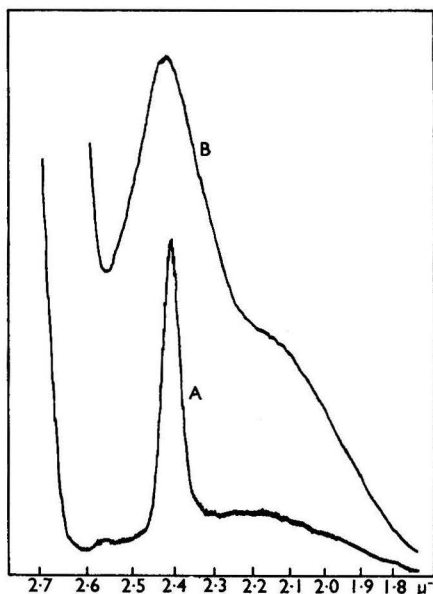

Fig. 3. Effect of slit width on fluorescence and Raman spectra when  $0.001 \mu\text{g}$  per ml of quinine sulphate in  $0.1 N$  sulphuric acid is excited by  $365\text{-m}\mu$  light: curve A, slit width of  $0.25 \text{ mm}$ ; curve B, slit width of  $1.75 \text{ mm}$  and lower sensitivity

power being acceptable, since the quinine band is very broad). However, the narrow Raman band would then appear to be considerably broadened and might be mistaken for part of the structure of the quinine band. This is shown by Fig. 3, in which the spectrum of a solution containing  $0.001 \mu\text{g}$  of quinine sulphate per ml has been recorded both with narrow slits and with wide slits. The interference could be allowed for by making measurements on the solvent alone, without the addition of quinine, but it might not be obvious that the interference was caused by the Raman effect and not by fluorescent impurities in the solvent. If the purification of the solvent itself were being studied, it would not be possible to carry out such a blank measurement, at least without carrying out further purification procedures on the solvent, and in such circumstances it would be important to recognise the secondary band as being caused by the Raman effect. That it was indeed so could be checked by measuring the fluorescence spectrum obtained with a shorter excitation wavelength; the fluorescence band of the quinine would then remain in its normal position, but the subsidiary band would move to a shorter wavelength, its frequency difference from that of the exciting light remaining constant. At the resolution used in recording the spectra in Figs. 1 and 2, it is comparatively easy to spot the interference by the narrow Raman spectrum when superimposed on a broad fluorescence spectrum. The interference becomes more troublesome when superimposed on a fluorescence spectrum showing vibrational structure. For example, Fig. 5 shows the fluorescence spectra of a series of very dilute solutions of anthracene in *cyclohexane*. It can be

seen that the narrow Raman band of the solvent completely distorts the shape of the spectrum of the most dilute solution, which appears to have an additional vibrational band. Appreciable distortion of the spectrum occurs up to concentrations of anthracene as high as  $0.075 \mu\text{g}$  per ml. When fluorescence emission spectra are used to identify very low concentrations of unknown materials, it is obviously important to keep the possibility of such interference

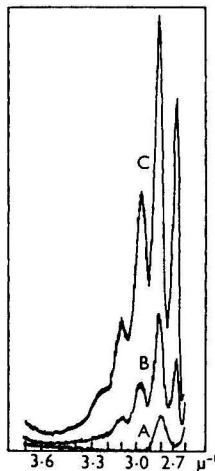

Fig. 4

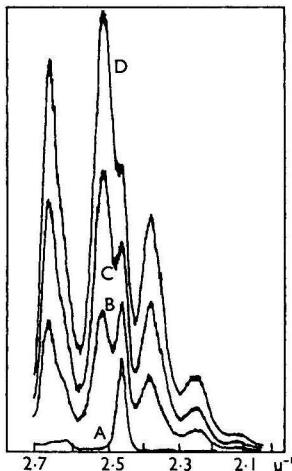

Fig. 5

Fig. 4. Excitation spectra of anthracene in *cyclohexane* with fluorescence monochromator set at  $397 \text{ m}\mu$ : curve A, pure solvent; curve B,  $0.007 \mu\text{g}$  per ml; curve C,  $0.025 \mu\text{g}$  per ml

Fig. 5. Emission spectra of anthracene in *cyclohexane* with excitation of  $365 \text{ m}\mu$ : curve A, pure solvent; curve B,  $0.025 \mu\text{g}$  per ml; curve C,  $0.05 \mu\text{g}$  per ml; curve D,  $0.075 \mu\text{g}$  per ml

constantly in mind. Here again, a measurement of the pure solvent will indicate the magnitude of the interference, or, if this is not possible, the use of a different wavelength for excitation will indicate those bands caused by Raman spectra.

#### INTERFERENCE WITH FLUORESCENCE EXCITATION SPECTRA

Fig. 4 shows the excitation spectra of two dilute solutions of anthracene in *cyclohexane*. These spectra should, of course, be identical with the absorption spectrum of anthracene in the same solvent,<sup>2</sup> but are in fact distorted by the band at  $2.81 \mu^{-1}$ , which appears in the excitation spectrum of the solvent itself. In these experiments, the fluorescence monochromator was set at  $2.52 \mu^{-1}$  ( $397 \text{ m}\mu$ ) with comparatively wide slits. The fluorescence monochromator was thus set up to receive the Raman spectrum of *cyclohexane* produced by exciting light of wave-number  $0.29 \mu^{-1}$  greater than this value, *i.e.*,  $2.81 \mu^{-1}$ . As the wave-number setting of the exciting monochromator passed through the region near  $2.81 \mu^{-1}$ , the corresponding Raman emission was thus picked up by the fluorescence monochromator and recorded as a band, as indicated. Owing to the wider slit widths used when excitation spectra are recorded, the Raman spectrum appears as a somewhat broader band in this instance. That the interference is caused by the Raman effect can be demonstrated by varying the setting of the fluorescence monochromator; the Raman band appearing in the excitation spectrum will shift accordingly.

#### INTERFERENCE WITH FILTER FLUORIMETRY

When fluorescence measurements are made with light of wavelength  $365 \text{ m}\mu$  filtered from a mercury lamp by means of, for example, an OX1 glass (effective cut-off at about  $400 \text{ m}\mu$ ), it is normally assumed that, to avoid interference by scattered exciting light, it is simply

necessary to use a secondary filter having zero transmission below  $410\text{ m}\mu$ . However, the Raman band of water excited by light of wavelength  $365\text{ m}\mu$  appears at  $416\text{ m}\mu$ , and, to avoid a high blank reading from this band when working at high sensitivity, the secondary filter must not transmit below about  $430\text{ m}\mu$ . Similarly, if the mercury line at  $405\text{ m}\mu$  is used for excitation (Raman band for water at  $469\text{ m}\mu$ ), the secondary filter must not transmit appreciably below about  $480\text{ m}\mu$  if high blank readings are to be avoided. In some circumstances, this means that the choice of secondary filters can be critical and the rejection of part of the required fluorescence band of the substance may have to be accepted. The fluorimetric determination of minute amounts of borate by reaction with benzoic acid to form a fluorescent compound is an example of this.<sup>1</sup> Fluorescence of the borate compound can readily be excited by light of wavelength  $365\text{ m}\mu$ , and the fluorescence emission spectrum of a solution containing  $0.004\text{ }\mu\text{g}$  of boron per ml is shown in Fig. 6. Maximum emission occurs at  $2.1\text{ }\mu^{-1}$  (approximately  $480\text{ m}\mu$ ) and is well separated from the Raman band of the mixed solvent, which appears at  $409$  to  $416\text{ m}\mu$  on the extreme edge of the emission band. A pale-yellow filter that cuts off at about  $2.38\text{ }\mu^{-1}$  is therefore adequate to remove interference caused by

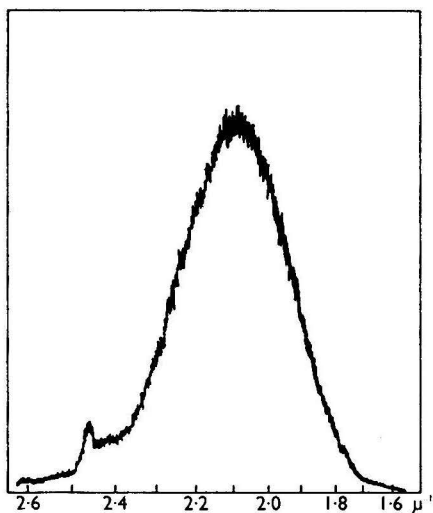

Fig. 6

Fig. 6. Emission spectrum of borate - benzoic acid solution (alkaline aqueous - alcohol) containing  $0.004\text{ }\mu\text{g}$  of boron per ml; exciting wavelength  $365\text{ m}\mu$

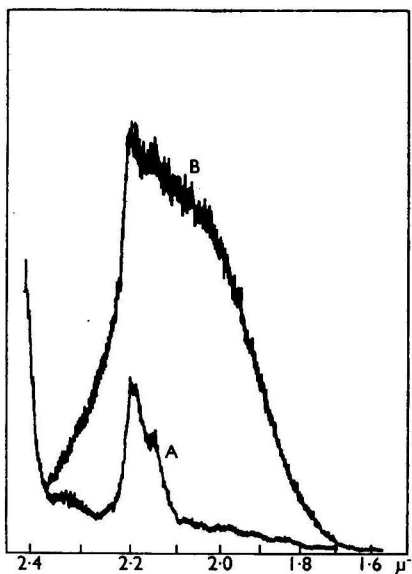

Fig. 7

Fig. 7. Emission spectra of borate solution in alkaline aqueous - alcohol ( $0.004\text{ }\mu\text{g}$  of boron per ml); exciting wavelength  $405\text{ m}\mu$ : curve A, before addition of benzoic acid; curve B, after addition of benzoic acid

the Raman effect. For various reasons<sup>1</sup> it is advantageous to use the mercury line at  $405\text{ m}\mu$  for excitation. Unfortunately, the boron compound absorbs much less strongly at  $405\text{ m}\mu$ . The intensity of fluorescence at a given intensity of exciting light is therefore much lower, and, in comparison, the Raman band of the mixed solvent is relatively much greater. This is shown by Fig. 7, in which the emission spectrum of the same solution was recorded before and after reaction with benzoic acid. Before reaction, the double peak caused by the mixed ethanol-water solvent is clearly visible and appears at a point not far removed from the wavelength of peak fluorescence emission from the boron compound. As a result, the spectrum of the latter is considerably distorted, and, to avoid a high blank reading from the Raman effect, the secondary filter must be chosen to cut off at a wave-number not greater than  $2.08\text{ }\mu^{-1}$  ( $480\text{ m}\mu$ ). This results in a lower over-all sensitivity, but fortunately this is acceptable, owing to the high instrumental sensitivity available.



## APPLICATION OF RAMAN SPECTRA

With a direct-reading spectrofluorimeter of high sensitivity, such as was used for this work, it is difficult to achieve accurately reproducible instrumental sensitivity from day to day, owing to slight drifts in photomultiplier E.H.T. supply or to drifts in the amplifier system. It is therefore customary to use a dilute solution of a standard substance, *e.g.*, quinine sulphate in sulphuric acid, to set the instrument at a given sensitivity level. In so doing, it is of course necessary to standardise the slit widths of the two monochromators and the wavelengths used for excitation of the standard substance. The substance to be measured may require different wavelengths for excitation and different settings of the fluorescence monochromator, but it is still possible to use the same standard substance by setting on the standard with the fluorescence monochromator at one wavelength and then measuring the unknown after the fluorescence monochromator has been altered to the second wavelength. Similarly, when the excitation wavelength has to be altered from standard substance to unknown substance, the instrument can be set on the standard substance at a given irradiating intensity, as indicated by the fluorescence screen monitor, and, when the excitation wavelength is altered, the intensity of the exciting light can readily be brought back to the same value by adjustment of the slit width of the exciting monochromator. However, when many spectra have to be recorded and both monochromators have to be re-set between measurements of standard and unknown, the various adjustments required can be somewhat time-consuming. If, however, the instrument is working at high sensitivity, so that the Raman spectrum of the solvent is readily observable, the Raman band can be used as an internal standard, since at any given wavelength of excitation and slit settings of the monochromators, its height at constant instrumental sensitivity will be constant. If, therefore, recordings of solutions are made on different days at different instrumental sensitivities, the results can readily be converted to the same basis by comparing the relative heights of the Raman band. The necessity for making measurements on a standard substance is thus avoided.

The apparatus used for the work described was designed to measure fluorescence excitation and emission spectra. The optical path through the liquid had been kept to a minimum (1 cm) in order to minimise the volume of sample required and the inner-filter effects that can occur when fluorescence measurements are made on mixtures of strongly absorbing substances. The design was therefore far from ideal for the observation of Raman spectra, for which the observable optical path through the liquid should be as long as possible. The ability of a spectrofluorimeter to resolve the various features of a Raman spectrum can be used as a measure of its sensitivity and resolution. A rapid recording of the Raman spectrum of, say, cyclohexane, provides a useful check to show that all components of the apparatus are working satisfactorily. To a lesser extent, measurement of a Raman spectrum could be used to compare the performances of different instruments in different laboratories, although the maximum sensitivity that could be used would, of course, depend on the degree of damping applied to the amplifier output and hence on the time taken to record the spectrum. Little damping was applied in the work described, and an appreciable noise level appeared on the recorder charts. An approximate spectrum could be recorded in 1 to 2 minutes, but, to obtain greater precision in locating peaks, the recording time was increased to about 5 minutes for the curves in Fig. 1.

I thank the Superintendent, Admiralty Materials Laboratory, for permission to publish this paper.

## REFERENCES

1. Parker, C. A., and Barnes, W. J., *Analyst*, 1957, **82**, 606.
2. Parker, C. A., *Nature*, 1958, **182**, 1002.
3. —, *Proc. Roy. Soc. A*, 1953, **220**, 104.
4. Hatchard, C. G., and Parker, C. A., *Ibid.*, 1956, **235**, 518.
5. Hibben, J. H., "The Raman Effect and Its Chemical Applications," Reinhold Publishing Corporation, New York, 1939, p. 322.

Received January 30th, 1959

## Notes

### THE ADDITIVE EFFECT OF SUBSTITUENT GROUPINGS ON THE CHROMATOGRAPHIC BEHAVIOUR OF PHENOXYACETIC ACIDS

(Presented at the meeting of the Society on Wednesday, April 1st, 1959)

It has for some time been recognised that chromatographic behaviour may be dependent on chemical structure.

The effect of the number of substituent groupings on the  $R_F$  values of a series of compounds has been shown to be additive.<sup>1,2</sup> As graphs of  $R_M$ , *i.e.*,  $\log_{10}[(1 - R_F)/R_F]$ , against the number of substituent groupings were linear for many series of compounds, *e.g.*, hydroxy compounds,<sup>2</sup> carbohydrates,<sup>3,4</sup> amino acids<sup>5,6</sup> and carboxylic acids,<sup>7,8,9</sup> we decided to investigate the behaviour of phenoxyacetic acid and some substituted phenoxyacetic acids in various solvent mixtures containing *n*-butyl alcohol.

The effect of the pH of the solvent system on the  $R_F$  values of amino acids was pointed out by Consden, Gordon and Martin,<sup>10</sup> who indicated that an increase in pH rendered the acidic substances more soluble in the stationary layer, thereby decreasing the  $R_F$  value, and that an acid pH caused the basic acids to behave in an analogous manner.

Brown<sup>11</sup> found that the  $R_F$  values of some lower fatty acids in systems containing *n*-butyl alcohol and various amounts of ammonia decreased as the pH of the solvent increased.

#### EXPERIMENTAL

A 0.0025-ml portion of a 1 per cent. w/v solution of each acid was placed on a sheet of Whatman No. 1 filter-paper that had previously been treated with ammonia vapour.

The acids were chromatographed in the machine direction of the paper by an ascending technique for 13½ hours at 20° C.

The chromatograms were developed with a 0.04 per cent. w/v solution of bromocresol purple in a (1 + 5) mixture of formaldehyde and absolute ethanol that had been brought to pH 5<sup>12</sup>; they were then exposed to ammonia vapour.

The acids appeared as yellow spots on a purple background, which rapidly faded, but was periodically regenerated by exposure to ammonia vapour.

A standard solution of phenoxyacetic acid was also applied to each sheet; those sheets on which the  $R_F$  value for the phenoxyacetic acid varied by more than 0.02 from a pre-determined mean were discarded.<sup>2,13</sup>

The appearance of the spots altered with each solvent. In *n*-butyl alcohol saturated with water, the spots were slightly diffuse and comet-like, the tail being against the direction of the solvent flow. In *n*-butyl alcohol saturated with 1.5 *N* ammonium hydroxide, the spots were well defined and slightly eccentric. In *n*-butyl alcohol saturated with 3.0 *N* ammonium hydroxide, the spots again had a comet-like appearance, the tail being in the direction of the flow, *i.e.*, preceding the spot.

Graphs of  $R_M$  against number of substituent groupings for these acids were linear for the three solvents.

#### RESULTS

For the series of phenoxyacetic acids investigated, we have found that the  $R_F$  values increased as the amount of ammonia in the solvent system was increased; the results are shown in Table I.

TABLE I  
VALUES OF  $R_F$  AND  $R_M$  FOR PHENOXYACETIC ACIDS IN SYSTEMS CONTAINING  
*n*-BUTYL ALCOHOL

Acid	Solvent A*		Solvent B†		Solvent C‡	
	$R_F$	$R_M$	$R_F$	$R_M$	$R_F$	$R_M$
Phenoxyacetic .. .. .	0.223	0.542	0.235	0.513	0.329	0.310
<i>o</i> -Chlorophenoxyacetic .. .. .	0.295	0.378	0.304	0.360	0.412	0.156
<i>p</i> -Chlorophenoxyacetic .. .. .	0.287	0.395	0.322	0.323	0.423	0.135
2:4 Dichlorophenoxyacetic .. .. .	0.367	0.327	0.412	0.155	0.495	0.009
2:4:6-Trichlorophenoxyacetic .. .. .	0.430	0.123	0.498	0.003	0.551	-0.090
<i>p</i> -Methylphenoxyacetic .. .. .	0.268	0.436	0.315	0.338	0.364	0.242
2:4-Dimethylphenoxyacetic .. .. .	0.365	0.240	0.421	0.138	0.450	0.087
2:3:5-Trimethylphenoxyacetic .. .. .	0.405	0.167	0.469	0.054	0.501	-0.002

\* *n*-Butyl alcohol saturated with water.

† *n*-Butyl alcohol saturated with 1.5 *N* ammonium hydroxide.

‡ *n*-Butyl alcohol saturated with 3.0 *N* ammonium hydroxide.

We thank Mr. J. Hall for preparing most of the acids used.

## REFERENCES

1. Martin, A. J. P., *Biochem. Soc. Symp.*, 1949, **3**, 4.
2. Bate-Smith, E. C., and Westall, R. G., *Biochem. Biophys. Acta*, 1950, **4**, 427.
3. French, D., and Wild, G. M., *J. Amer. Chem. Soc.*, 1953, **75**, 2612.
4. Levy, M. F., *Anal. Chem.*, 1954, **26**, 1849.
5. Serchi, G., *Ann. Chim. Roma*, 1953, **43**, 253.
6. Van Espen, J., *Med. Vlaam. Chem. Ver.*, 1953, **15**, 66.
7. Long, A. G., Quayle, J. R., and Stedman, R. J., *J. Chem. Soc.*, 1951, 2197.
8. Kobrie, V., and Zahradnik, R., *Chem. Listy*, 1954, **48**, 1189.
9. Reichl, E. R., *Monatsh.*, 1955, **86**, 69.
10. Conden, R., Gordon, A. H., and Martin, A. J. P., *Biochem. J.*, 1944, **38**, 224.
11. Brown, F., *Ibid.*, 1947, **47**, 5.
12. Reid, R. L., and Lederer, M., *Ibid.*, 1951, **50**, 60.
13. Saifer, A., and Oreskes, I., *Anal. Chem.*, 1953, **25**, 1539.

CHEMISTRY DEPARTMENT  
DERBY AND DISTRICT COLLEGE OF TECHNOLOGY  
GREEN LANE, DERBY

L. S. BARK  
R. J. T. GRAHAM  
Received December 10th, 1958

## DISCUSSION

DR. J. H. HAMENCE congratulated the authors on their efforts to obtain more theoretical data to explain chromatographic separations. In his view the amount of theoretical information available on the subject of chromatographic behaviour was lamentably poor. He deprecated the very widespread use of the "hit and miss" technique even in some of the world's leading laboratories. The procedure of trying all the reagents as eluants until a satisfactory one was found was in his view deplorable in this enlightened age. Sooner or later the whole matter would have to be put on a theoretical basis. Finally he asked the authors whether they had considered the variations in the solubility of the various phenoxyacetic acids in relation to their behaviour on elution. In spite of theories to the contrary, it had been his long experience that plain solubility played a most important part in nearly all chromatographic separations and provided not only a simple explanation of the behaviour of different solvents but was also a useful guide in selecting suitable eluants.

MR. BARK agreed that great consideration had to be given to the choice of solvent. They had briefly investigated the solubility of the acids used in some of the lower alcohols and had found that, in general, the solubility of the acids decreased with increase in molecular weight of acid and of solvent.

However, when they used the lower alcohols, in which the acids were reasonably soluble, as eluting agents, the spots produced on the chromatograms were not of uniform shape and were not considered standard enough to enable accurate measurements to be made. Since one of the major parts of the work was an attempt to obtain standard conditions, the solvent that gave the best shaped spots was considered to be the best. For this reason *n*-butyl alcohol had been chosen as the base of the solvent systems.

### THE SEPARATION AND COLORIMETRIC DETERMINATION OF COBALT IN PRESENCE OF COPPER AND NICKEL

(Presented at the meeting of the Society on Wednesday, April 1st, 1959)

RECENT investigations in this laboratory into the differential extraction of copper and cobalt with dithizone at different pH values<sup>1</sup> have shown that this method is not altogether reliable, particularly with microgram amounts of cobalt.

A system was investigated whereby the metals were first extracted at pH 8 with a solution of 8-hydroxyquinoline (oxine) in chloroform. The chloroform extract was evaporated and ashed, and the residue was submitted to paper-chromatographic separation. After location of the cobalt area with rubeanic acid, this part of the paper was cut out, ashed and re-dissolved, and the cobalt was determined colorimetrically with nitroso-R salt.<sup>1</sup>

The purpose of the oxine extraction was to separate copper, cobalt, nickel, zinc, iron, molybdenum, etc., from large amounts of calcium, magnesium, sodium, potassium, etc., which do not form chloroform-soluble oxinates. The extractable oxinates produce an ash of low bulk that can be dissolved in a volume of 0.1 to 0.2 ml, the whole of which can be quantitatively applied to a sheet of chromatography paper.

Under the conditions described below, separations and recoveries were excellent, and the method was found to be quantitatively applicable to 0.5 to 50  $\mu$ g of cobalt in presence of copper and nickel, in amounts from 0.5 to 50  $\mu$ g, and a large excess of iron.

## METHOD

## REAGENTS—

*Oxine solution*—A 1 per cent. solution of 8-hydroxyquinoline in chloroform.

*Solvent mixture*—Mix 15 volumes of ethyl methyl ketone, 3 volumes of concentrated hydrochloric acid and 2 volumes of water.

*Rubeanic acid solution*—A 1 per cent. solution of dithio-oxamide in ethanol - water mixture (3 + 2).

*Phenol red indicator solution.*

## PROCEDURE—

Place an aliquot of sample solution in a 200-ml separating funnel, and dilute to between 50 and 100 ml. Adjust the pH to 8 with ammonia - citric acid mixture (phenol red indicator).

Shake vigorously with 25 ml of oxine solution for 5 minutes, allow to separate, and run off the chloroform layer into a silica crucible. Place the crucible on a bath of boiling water, and evaporate. Repeat the oxine extraction until the chloroform layer is colourless, and add the successive washings to the crucible. When all the chloroform has evaporated, carefully ash the residue in the crucible, heat to dryness with a little aqua regia, and dissolve in 0.1 to 0.2 ml of 50 per cent. hydrochloric acid.

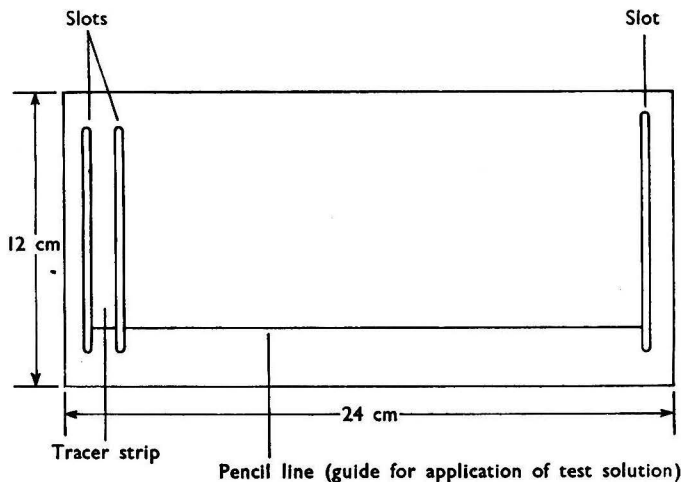

Fig. 1. Details of chromatography paper

With a capillary pipette, apply the whole of this solution to a sheet of chromatography paper (see Fig. 1). Clip the paper into a cylinder, and place it in a beaker containing 20 ml of solvent mixture. Cover the beaker, and set it aside until the solvent front has progressed about three-quarters of the way up the paper. Remove the paper, dry in air for 5 minutes, and neutralise in ammonia vapour. Spray the paper with rubeanic acid solution. The cobalt zone will be observed as a yellow band midway between the upper copper band (olive green) and the lower nickel band (blue).

Dry the paper, cut out the appropriate section, and ash it at 550° C. Treat the ash with aqua regia, and dissolve it in dilute hydrochloric acid. Determine cobalt colorimetrically with nitroso-R salt.<sup>1</sup>

If the amounts of metals present are less than 2  $\mu\text{g}$ , the coloured zones may not be plainly visible. In such instances, it is recommended that a parallel "tracer strip," 1.5 cm wide, be incorporated in the paper. To this strip, apply 0.01 ml of a solution containing, about 2  $\mu\text{g}$  each of copper, cobalt and nickel. After colour development, this strip will clearly indicate the positions of the respective zones.

## RESULTS

The proposed method was used in a series of recovery experiments with 20- $\mu$ g portions of cobalt; the results were as follows—

Amount of cobalt and nickel present, $\mu$ g ..	20.0	40.0	60.0	80.0	100.0
Amount of cobalt extracted, $\mu$ g .. ..	19.6	20.0	20.5	19.0	18.6
Amount of cobalt found in aqueous phase, $\mu$ g ..	0.4	0.5	0.4	0.8	0.6

## REFERENCE

1. Marston, H. R., and Dewey, D. W., *Austral. J. Exp. Biol. Med. Sci.*, 1940, 18, 346.

26, PARK CRESCENT  
PORTLAND PLACE  
LONDON, W.1

W. D. DUFFIELD  
Received October 21st, 1958

## DISCUSSION

MR. N. T. WILKINSON asked whether the oxinates and the chromatograms were dry-ashed, and, if so, what losses of metals occurred.

MR. DUFFIELD replied that the oxinates were dry ashed at 500° C, after very careful preliminary heating in which ignition to flames had to be avoided. Under those conditions no serious losses occurred. The second ashing, that of the paper chromatogram, should be a wet ashing, as appreciable losses had been experienced with dry ashing. This applied particularly to copper.

MR. C. WHALLEY confirmed that the separation was satisfactory but did not like the second ashing of the paper before the determination of cobalt. This definitely caused losses. He also said that he had had difficulty in getting the paper into the correct state of humidity to carry out the separation. His early attempts had been failures. The water content of the paper was very critical.

MR. DUFFIELD agreed with Mr. Whalley's comments on the two ashing procedures: wet ashing the paper had proved essential. He agreed also that the humidity of the paper was critical, and stressed the importance of strict adherence to the specific recommendations of Hunt, North and Wells (*Analyst*, 1955, 80, 172), *viz.*, 3 minutes at 80° C. Satisfactory results had also been obtained with 30 minutes at room temperature, but this method was subject to prevailing atmospheric conditions.

DR. J. H. HAMENCE commented that in his experience it was not so much the humidity of the chromatographic paper that was critical as the proportion of moisture in the developing or eluting reagent. He had found that only by the use of freshly prepared eluting reagents were satisfactory results obtained. Dr. Hamence also raised the question of the extraction of the copper, cobalt and nickel by a chloroform solution of 8-hydroxyquinoline when a large proportion of iron was also present. His experience was that this often caused trouble, and it was difficult to decide when the extraction of the metals to be determined had been completed. He pointed out that this problem often arose in dealing with highly ferruginous soils, and the problem of determining a few parts per million of cobalt in ferruginous soils containing, say, 20 per cent. of iron oxide was by no means an easy matter, even by metallurgical methods.

MR. DUFFIELD agreed with Dr. Hamence's remarks on the stability of the developing solvent: it was his own practice to mix the components freshly for each individual chromatogram. Up to three papers could be run consecutively in the same solvent mixture provided that the chromatographic vessel was kept covered and that there was no appreciable time lag between runs.

As to the oxine extraction of soil ashes, it could only be assumed that copper and cobalt had been completely extracted when a colourless chloroform solution was obtained. For soils that were highly ferruginous, this could indeed give trouble. The situation did not arise with the general range of crops, fertilisers and feeding stuffs.

## THE NON-AQUEOUS TITRATION OF PHENOLIC HYDROXYL

WHEN the total phenolic hydroxyl content of coal-tar or pitch fractions is determined, it is important to bear in mind that these substances would be expected to contain mixtures of monohydric and polyhydric phenols having wide molecular-weight ranges. Hydrogen-bonding, which is believed to play a major part in determining the physical characteristics of tars and pitches, may result in a large proportion of the phenolic hydroxyl being relatively inaccessible to chemical reagents, and esters and other oxygen-containing groups may affect the determination.

## EXPERIMENTAL

With 0.2 N sodium aminoethoxide as titrant, three solvent-electrode systems were tried these systems were—

- (i) pyridine with antimony indicating electrode and platinum reference electrode.

- (ii) ethylenediamine with antimony indicating electrode and platinum reference electrode, and
- (iii) ethylenediamine with anodised platinum indicating electrode and platinum reference electrode.

On the basis of titration of a tar-acid fraction and resorcinol, the first system was selected as being the best combination; equilibrium was rapidly established when commercial pyridine was used, and results of high sensitivity and reproducibility were obtained.

The procedure was similar to that used by Katz and Glenn<sup>1</sup>; the apparatus used has been described elsewhere.<sup>2,3</sup> About 0.1 g of sample was dissolved or suspended in 20 ml of solvent and titrated potentiometrically, in an atmosphere of pure nitrogen, with 0.2 *N* sodium aminoethoxide in ethylenediamine, the titrant being added in 0.1-ml portions. After each addition, the sample was stirred until the millivoltmeter showed a steady reading (from 2 to 15 minutes), and a further 0.1 ml of titrant was then added. A single titration took about 2 hours.

Precipitation of their sodium salts hindered the titration of many of the weakest phenols, *e.g.*, catechol and hydroquinone. However, when 2:6-xylenol was added, the precipitation no longer affected the sharpness of the final end-point.

In tests on low-temperature tars (generally considered to contain catechol<sup>4</sup> in addition to simple monohydric phenols) only one end-point was discernible. Its significance was determined by titrating catechol, hydroquinone and resorcinol singly and mixed with 2:6-xylenol. Single sharp inflexions, at the calculated values for total phenolic hydroxyl content, were obtained for the three mixtures, but the titration curves for the individual dihydroxybenzenes were unsatisfactory (see Fig. 1). Determinations based on the single inflexions obtained when tar acids were titrated would therefore include the dihydroxybenzenes together with phenol and cresols, and it would seem that the total acidic hydrogen of the polyhydric phenols was titrated with the phenol at the single inflexion. Because of this, more complex polyhydric phenols were investigated.

The titration curves for two selected dihydroxynaphthalenes in admixture with 2:6-xylenol each had one sharp inflexion corresponding closely to the theoretical amount of total phenolic hydroxyl present. The apparent levelling effect of 2:6-xylenol on the titration curve for polyhydric hydroxylic groupings was most marked with these dihydroxynaphthalenes, as in absence of xylenol each hydroxyl group could be titrated separately, sharp inflexions being obtained.

The five hydroxyquinones of naphthalene and anthracene shown below were examined to determine whether or not hydrogen-bonding between the quinone and hydroxylic groups would affect the determination.

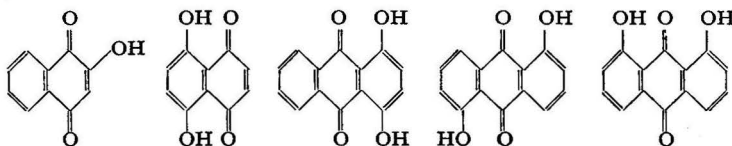

Of these compounds, only 5:8-dihydroxy-1:4-naphthaquinone presented any difficulty in titration: alone, approximately 50 per cent. of the phenolic hydroxyl was found to react; with 2:6-xylenol, the titration curve had a weak but almost theoretically correct inflexion for total phenolic hydroxyl content. The dihydroxyanthraquinones gave sharp final end-points, either alone or with 2:6-xylenol.

Titration curves for saligenin, 2-naphthyl acetate and pyrogallol had one inflexion with 2:6-xylenol. The alcoholic hydroxyl of saligenin was unaffected, the phenolic ester underwent aminolysis to form 2-naphthol and the amide (presumably of ethylenediamine<sup>5</sup>), and the three hydroxylic groups of the polyhydric phenol titrated as one.

The titration curve for a mixture of 2:6-xylenol, catechol, 1:5-dihydroxynaphthalene and 1:8-dihydroxyanthraquinone had one sharp inflexion at the theoretically required point.

In Table I, the equivalent weights of certain phenolic compounds determined by titration in admixture with 2:6-xylenol are compared with the theoretical values; the results indicate the value of the method for determining total phenolic hydroxyl. Some typical titration curves are shown in Fig. 2.

Neither carbazole nor indole can be titrated in pyridine when antimony electrodes are used, even in presence of 2:6-xylenol. Separate weak inflexions for both 2:6-xylenol and carbazole were obtained when the mixture in ethylenediamine was titrated with use of antimony electrodes.

TABLE I

APPLICABILITY OF TITRATION PROCEDURE TO PHENOLIC COMPOUNDS  
The compounds were stock reagents and were used without further purification

Compound	Theoretical equivalent weight	Equivalent weight by titration in admixture with 2:6-xyleneol
Hydroquinone .. .. .	55	57
Catechol .. .. .	55	56
Resorcinol .. .. .	55	55
1:3-Dihydroxynaphthalene .. .. .	80	77
1:5-Dihydroxynaphthalene .. .. .	80	81
2-Hydroxy-1:4-naphthaquinone .. .. .	174	176
5:8-Dihydroxy-1:4-naphthaquinone .. .. .	95	101
1:4-Dihydroxyanthraquinone .. .. .	120	119
1:5-Dihydroxyanthraquinone .. .. .	120	118
1:8-Dihydroxyanthraquinone .. .. .	120	119
Pyrogallol .. .. .	42	37
Saligenin .. .. .	124	123

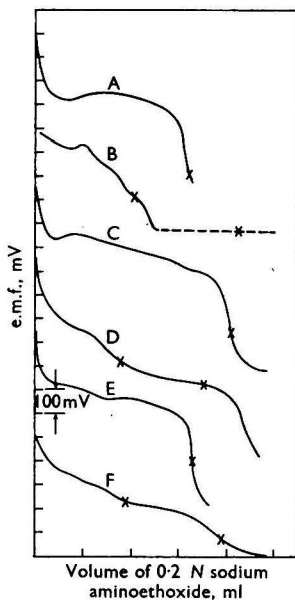

Fig. 1. Titration curves for hydroquinone, catechol and resorcinol, both individually and with addition of 2:6-xyleneol: curve A, hydroquinone *plus* 2:6-xyleneol; curve B, hydroquinone; curve C, catechol *plus* 2:6-xyleneol; curve D, catechol; curve E, resorcinol *plus* 2:6-xyleneol; curve F, resorcinol. Theoretical end-points are indicated by crosses

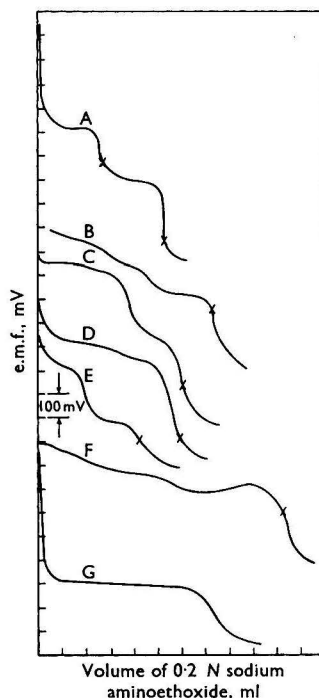

Fig. 2. Typical titration curves for phenolic compounds: curve A, 1:3-dihydroxynaphthalene; curve B, 1:3-dihydroxynaphthalene *plus* 2:6-xyleneol; curve C, 1:5-dihydroxynaphthalene *plus* 2:6-xyleneol; curve D, pyrogallol *plus* 2:6-xyleneol; curve E, 2-hydroxy-1:4-naphthaquinone *plus* 2:6-xyleneol; curve F, a mixture of 2:6 xyleneol, catechol, 1:5-dihydroxynaphthalene and 1:8-dihydroxyanthraquinone; curve G, a tar acid-fraction. Theoretical end-points are indicated by crosses

After the foregoing experimental work had been completed, publication of Walker, Henry and Davis's findings<sup>6</sup> suggested the desirability of determining the effect of other simple quinones—anthraquinone, 1:2-benzanthraquinone, phenanthraquinone and 2:6-xyloquinone—on the titration.

2:6-Xyloquinone behaved as the strongest acid; it reacted with approximately one equivalent of sodium aminoethoxide per molecule, and the titration curve had a definite inflexion (see Fig. 3, curve C).

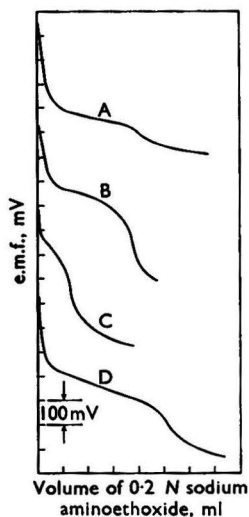

Fig. 3. Titration curves for simple quinones: curve A, 1:4-naphthaquinone plus 2:6-xyleneol; curve B, acenaphthenequinone plus 2:6-xyleneol; curve C, 2:6-xyloquinone; curve D, 2:6-xyloquinone plus 2:6-xyleneol

1:4-Naphthaquinone and acenaphthenequinone appeared to be weakly acidic; the titration curves for these substances mixed with 2:6-xyleneol had single weak inflexions (see Fig. 3, curves A and B), each molecule of the quinone requiring approximately 0.6 equivalent of sodium aminoethoxide.

Phenanthraquinone gave a titration curve without inflexions, and anthraquinone and 1:2-benzanthraquinone were unreactive.

The apparent titration of the more reactive quinones must be ascribed to chemical reaction with the titrant. Quinones of the benzene series are known to react with aqueous alkali in the absence of substituents having steric effects; phenanthraquinone undergoes rearrangement to 9-hydroxyfluorene-9-carboxylic acid, and acenaphthenequinone forms 7:8-naphthaldehydic acid in aqueous alkali. Similar changes appear to occur during the addition of sodium aminoethoxide in the non-aqueous system, and titrant is consumed although the original quinones have no acidic groups.

#### APPLICATION OF THE METHOD

The titration procedure described has been applied to some hundreds of samples of coal tars and pitches by the Coal Research Section of C.S.I.R.O., and the results have been used to establish the polar nature of the less-soluble fractions of coal tars and pitches and so to provide further evidence that molecular association may largely determine the physical properties of pitch.<sup>9</sup> The procedure could be advantageously used in the routine analysis of the normal alkali-soluble tar-acid fraction (see Fig. 2, curve G).



If phenolic esters, lactones of phenols and certain quinones are absent, the procedure is suitable for determining both monohydric and polyhydric phenolic hydroxyl in coal tar and pitch. The proportions of quinones that are reactive to alkali would be insufficient to affect markedly the accuracy of the determination of phenolic hydroxyl.

## REFERENCES

1. Katz, M., and Glenn, R. A., *Anal. Chem.*, 1952, **24**, 1157.
2. Brooks, J. D., and Maher, T. P., *Fuel*, 1957, **36**, 51.
3. Greenhow, E. J., and Smith, J. W., *Ibid.*, 1958, **37**, 354.
4. Williams, A. F., *Chem. & Ind.*, 1955, 148.
5. Glenn, R. A., and Peake, J. T., *Anal. Chem.*, 1955, **27**, 205.
6. Walker, W. E., Henry, J. P., and Davis, H. G., *Fuel*, 1958, **37**, 345.

COMMONWEALTH SCIENTIFIC AND  
INDUSTRIAL RESEARCH ORGANIZATION  
COAL RESEARCH SECTION  
P.O. BOX No. 3, CHATSWOOD  
NEW SOUTH WALES, AUSTRALIA

E. J. GREENHOW  
J. W. SMITH

Received November 10th, 1958

### THE USE OF GAS CHROMATOGRAPHY FOR DETERMINING WATER IN PHARMACEUTICAL PREPARATIONS

A METHOD has recently been described for determining chloroform in aqueous samples by gas chromatography.<sup>1</sup> During the development and operation of the method it was noted that the amount of tailing of the water peak was not so great as might be expected for the size of sample and its high water content. It therefore seemed likely that chromatographic conditions might be chosen so as to give reasonably symmetrical and sharp water peaks that could be used for quantitative determination. If this were so, then the apparatus used for determining chloroform might also be used for determining water in samples such as pastes, ointments, creams and emulsions, particularly as an essential feature of the equipment is a special injection system designed to prevent non-volatile materials from reaching the chromatographic column. Such a procedure has been devised and is described below.

The chemical determination of water is usually carried out either by the Dean and Stark procedure or by the Karl Fischer titration method. The former requires considerable care and attention during operation, particularly when frothing or other adverse effects occur, whereas the latter has the disadvantage of requiring objectionable reagents and is only applicable to materials that do not react with the reagents. The gas-chromatographic procedure, however, is simple, direct and rapid; it needs only small amounts of sample and has been shown to give good reproducibility and agreement with chemical analyses.

#### CALIBRATION—

Because of the difficulty of always transferring an exactly reproducible amount of sample to the column, an internal-standard procedure has been adopted; this procedure also compensates for any slight changes in conditions that might occur from day to day. As it has proved possible to choose conditions giving sharp and reasonably symmetrical water peaks and as these standard conditions can be generally maintained, it is possible to use peak heights rather than areas for calibration purposes.

The most suitable material for the internal standard is *n*-pentanol, which is eluted after the water. Lower alcohols are frequently present in many of the samples, so that their use as an internal standard is precluded, and higher alcohols give broad peaks unsuitable for peak-height measurements. Table I shows duplicate results of peak-height ratios for amounts of water from

TABLE I  
RATIO OF PEAK HEIGHTS OF WATER AND *n*-PENTANOL AT DIFFERENT  
CONCENTRATIONS OF WATER

Concentration of water, %	Concentration of <i>n</i> -pentanol, %	Ratio of peak heights
0.5	2.0	0.316, 0.318
1.0		0.685, 0.688
1.5		1.09, 1.10
2.0		1.51, 1.52

0.5 to 2.0 per cent. and 2 per cent. of *n*-pentanol. The agreement between duplicates is good and, within the accuracy of the method, the peak-height ratio is linearly related to the concentration of water. Slight variations in the slope of the calibration curve occur from day to day, but in practice it has been found necessary to check only two points, a procedure taking about 10 minutes.

## METHOD

## PROCEDURE—

Standard solutions containing 0.5, 1.0, 1.5 and 2.0 per cent. of chloroform and 2.0 per cent. of *n*-pentanol are prepared in acetone. The samples are shaken vigorously with acetone, diluted as necessary and 2.0 per cent. of *n*-pentanol are added. Standards and samples are examined by using the equipment previously described,<sup>1</sup> and a calibration curve is drawn by plotting the ratio of peak heights against percentage of water. The calibration curve does not pass through the origin because of the presence of a small amount of water in the acetone, which is B.P. grade dried for several days by standing over calcium chloride.

The conditions are as follows—

*Column length*—5 feet.

*Column temperature*—117° C.

*Stationary phase*—20 per cent. of Carbowax 1500 on 36 to 85-mesh Chromosorb.

*Carrier gas*—Hydrogen - nitrogen mixture (4 + 1) at flow rate of 100 ml per minute.

*Flash-heater temperature*—150° C.

*Detector*—Thermal-conductivity cell with platinum wires 4 inches long and 0.001 inch thick; nominal resistance 25 ohms, the wires in the two channels being matched to within 0.1 ohm.

*Detector current*—200 mA.

*Sample size*—30  $\mu$ l.

*Recorder*—Honeywell - Brown with 2.5-mV full-scale deflection and chart speed of 12 inches per hour.

The column characteristics under these conditions are as follows—

*Height equivalent to a theoretical plate*—0.32 cm.

*Retention volume (water)*—225 ml.

*Retention volume (n-pentanol)*—525 ml.

## RESULTS

Table II shows the results obtained for a variety of samples compared with those obtained by the Dean and Stark method.

TABLE II  
COMPARISON OF CHEMICAL AND GAS-CHROMATOGRAPHIC RESULTS

Sample	Water found by—	
	gas chromatography, %	Dean and Stark's method, %
Antazoline cream .. .. .	60.8	60.0
Sulphathiazole ointment .. .. .	46.0	47.5
Hydrous wool fat .. .. .	29.0	28.5
Zinc undecenoate ointment .. .. .	57.0	55.0
Stilboestrol ointment .. .. .	63.8	65.0
Cream Simple, B.P. . . . .	71.0, 70.0	70.0
Hand ointment .. .. .	29.7	30.0
Hair cream { (1) .. .. .	49.8	50.0
(2) .. .. .	50.0	50.0
Hair shampoo .. .. .	76.2	76.8
Skin food .. .. .	28.6	29.0
Lanoline cream shampoo { (1) .. .. .	62.2	} 63.0*
(2) .. .. .	64.5	
Complexion milk .. .. .	67.6	67.5
Foot comfort cream { (1) .. .. .	27.4	} 28.0*
(2) .. .. .	27.2	

\* Theoretical value.

## CONCLUSIONS

An assay can be performed by the proposed method in about 5 minutes. No sample preparation is necessary, other than dissolution in acetone and the addition of *n*-pentanol as internal standard. A calibration method by peak-height measurement is possible, as the conditions used give sharp and reasonably symmetrical peaks. Good reproducibility and agreement with chemical results are obtained.

We thank Mr. C. B. Baines for his help in obtaining some of the results quoted.

## REFERENCE

1. Brealey, L., Elvidge, D. A., and Proctor, K. A., *Analyst*, 1959, **84**, 221.

STANDARDS DEPARTMENT  
BOOTS PURE DRUG CO. LTD.  
BEESTON, NOTTINGHAM

D. A. ELVIDGE  
K. A. PROCTOR

Received January 28th, 1959

## A FIELD METHOD FOR THE DETERMINATION OF PHOSGENE

SEVERAL tests based on colour changes produced on test papers impregnated with *p*-dimethylaminobenzaldehyde together with diphenylamine,<sup>1</sup> dimethylaniline<sup>2,3</sup> or *N*-ethyl-*N*-2-hydroxyethylamine and diethyl phthalate<sup>4</sup> have been proposed for the detection of small amounts of phosgene in air. In these tests, absorption of phosgene is incomplete at concentrations of a few parts per million and at reasonable rates of sampling. The stains tend to penetrate the paper and to appear on the other side. Strictly controlled sampling conditions are therefore necessary to obtain quantitative results. This drawback, together with inadequate sensitivity and the transience of the stains, reduces the value of these tests from the quantitative, as distinct from the qualitative, point of view.

Brown, Wilzbach and Ballweber<sup>5</sup> suggested the use of papers impregnated with a mixture of 4-*p*-nitrobenzylpyridine, *N*-benzylaniline and sodium carbonate for detecting phosgene, the intensity of the colour produced being determined by photometric measurement of the optical transmittance. These reagents were incorporated with inert fillers and binders to form detector crayons by Witten and Probst.<sup>6,7</sup> Marks made on suitable surfaces by these crayons change colour on contact with phosgene. Lamouroux used solutions of 4-*p*-nitrobenzylpyridine to absorb phosgene from the atmosphere and determined the concentration of phosgene by spectrophotometric measurement of the colour intensity of the resulting liquor.<sup>8</sup>

We have now re-examined the replacement of dimethylaminobenzaldehyde by nitrobenzylpyridine for use in conjunction with an amine as a field test for phosgene.

## METHOD

## PROCEDURE—

Immerse 1-inch wide strips of Whatman No. 1 filter-paper in a solution containing 2 per cent. w/v of 4-*p*-nitrobenzylpyridine<sup>9</sup> and 4 per cent. w/v of *N*-benzylaniline in benzene. Remove the strips, and allow to drain and to dry in air. Place the test paper in a holder that exposes a circle of paper 1 cm in diameter,<sup>10</sup> and draw 120 ml of air through the paper at a rate not exceeding 3 ml per second by means of a rubber-bulb hand aspirator. Compare the red stain that appears if phosgene is present with standard stains representing 0.25, 0.5, 1, 2, 5 and 10 p.p.m. of phosgene in a 120-ml sample or with Lovibond glass colour standards (obtainable from Tintometer Ltd., Salisbury, Wilts).

If traces of chlorine are present, insert, on the inlet side of the test paper, a paper that has been previously soaked in an aqueous solution containing 4 per cent. w/v of sodium iodide and 10 per cent. w/v of sodium thiosulphate and then dried. This paper will also remove small amounts of hydrogen chloride, but the test paper is not affected by less than about 500 p.p.m. of this gas.

## DISCUSSION OF THE METHOD

The vapour of acetyl chloride, if present in appreciable amounts, will reduce the intensity of the stain, *e.g.*, 30 p.p.m. of acetyl chloride vapour will reduce by one half the intensity of the stain obtained from 0.5 p.p.m. of phosgene, and 140 p.p.m. of acetyl chloride will almost completely suppress the stain. Benzoyl chloride vapour will produce a transient stain, *e.g.*, a concentration of 100 p.p.m. yields an orange stain of similar colour intensity to that produced by 0.5 to

1 p.p.m. of phosgene, but in presence of 3 p.p.m. of benzoyl chloride only a barely perceptible stain is obtained. If benzoyl chloride and phosgene are present together, however, the colour produced by benzoyl chloride vapour fades after 3 minutes and leaves the phosgene stain unimpaired.

The presence of benzyl chloride, trichloroethylene or chloroform in concentrations up to 200 p.p.m. appears to have no effect on phosgene stains.

Concentrations of up to 10 p.p.m. of phosgene can be determined with reasonable accuracy. No deterioration in efficiency of the reagent solution or of the prepared test papers was detected after storage for several months.

The proposed test has several advantages over tests in which *p*-dimethylaminobenzaldehyde is used.<sup>1,2,3,4</sup> It is much more sensitive; an atmosphere containing 0.25 p.p.m. of phosgene produces a satisfactory colour on the specified test papers, whereas no colour, or a scarcely discernible colour, is produced when similar-sized papers based on *p*-dimethylaminobenzaldehyde are used. The stains are produced almost wholly on the surface of the test paper and do not fade for at least 2 hours.

This work was carried out on behalf of the Committee on Tests for Toxic Substances in Air and the Ministry of Labour and National Service. We thank the Government Chemist for permission to publish this Note.

#### REFERENCES

1. D.S.I.R., "Methods for the Detection of Toxic Gases in Industry, Leaflet No. 8: Phosgene," H.M. Stationery Office, London, 1939.
2. Moureu, H., Chovin, P., and Truffert, L., *Compt. Rend.*, 1949, **228**, 1954.
3. Hayashi, M., Okazaki, M., and Shinohara, Z., *J. Soc. Org. Syn. Chem. Japan*, 1954, **12**, 273.
4. Liddell, H. F., *Analyst*, 1957, **82**, 375.
5. Brown, W. G., Wilzbach, K. E., and Ballweber, E. G., Library of Congress, PB No. 5945, September, 1945.
6. Witten, B., and Prostak, A., *Anal. Chem.*, 1957, **29**, 885.
7. Anon., *Chem. & Ind.*, 1958, 754.
8. Lamouroux, A., *Mém. Poudres*, 1956, **38**, 383.
9. Tschitschibabin, A. E., Kuindshi, B. M., and Benewolenskaja, S. W., *Ber.*, 1925, **58**, 1580.
10. Dixon, B. E., Hands, G. C., and Bartlett, A. F. F., *Analyst*, 1958, **83**, 199.

DEPARTMENT OF THE GOVERNMENT CHEMIST  
CLEMENT'S INN PASSAGE  
STRAND, LONDON, W.C.2

B. E. DIXON  
G. C. HANDS

Received October 8th, 1958

#### THE EXTRACTION OF PIGMENTS FROM PLANT MATERIAL

IN a recently published monograph<sup>1</sup> there is described a simple method recommended by the Carotene Panel of the Analytical Methods Committee of the Society for Analytical Chemistry<sup>2</sup> for extracting carotenoids from biological materials. The green leaves or other materials were ground with quartz under a mixture of light petroleum, acetone and quinol. Two small changes in the procedure now make it possible to extract the pigments even more quickly than hitherto.

#### METHOD

##### PROCEDURE—

Small samples are weighed in beakers as described before.<sup>1,2</sup> About an equal weight of quartz and a few milligrams of quinol are added and then about 5 ml of acetone. The material is carefully ground in the beaker. About 5 ml of light petroleum, boiling range 40° to 60° C, are added. One minute or so is allowed for particles to settle; when several samples are treated concurrently, the first has settled by the time the light petroleum is added to the last. The solution is then decanted into a layer of light petroleum on a half-saturated aqueous solution of ammonium sulphate in a separator. The residue is ground thoroughly, acetone is added and then light petroleum, and the extract is decanted. The extraction and decantation are repeated as necessary. After the second extraction, the grist is kept damp by adding a few drops of water between extractions. When the pigment has all been extracted, the combined extracts are washed with water by means of an automatic arrangement and the remainder of the procedure is carried out as described before. Solvents are conveniently added to beakers and separators from squeeze-type wash-bottles.

## DISCUSSION OF THE METHOD

Acetone is probably the most effective solvent for rapidly extracting pigments from biological materials. However, acetone extracts cannot safely be decanted, because particles of grist remain suspended. Particles settle from light petroleum, but this solvent is ineffective for quantitative extraction of fresh plant material, probably because it does not dissociate the pigment from combination with protein. The proposed procedure exploits the advantages of each solvent in turn.

Pigments are required in light petroleum for chromatography; acetone must therefore be removed. This is usually done by washing with water in a separating funnel from which leakage of solution through the tap is prevented by sealing with water. If an acetone - light petroleum solution of pigments is poured into this water, a colloidal solution may be produced, from which the pigments cannot be extracted. The use of ammonium sulphate solution avoids this source of loss.

The proposed procedure has been used for extracting carotenoid esters, carotene, carotenols, chlorophylls, tocopherols and other biological substances from leaves, flowers and other parts of plants.

## REFERENCES

1. Booth, V. H., "Carotene: Its Determination in Biological Materials," W. Heffer & Sons Ltd., Cambridge, 1957.
2. Analytical Methods Committee, "The Determination of Carotene in Green-Leaf Material," *Analyst*, 1950, **75**, 568.

DUNN NUTRITIONAL LABORATORY  
UNIVERSITY OF CAMBRIDGE AND MEDICAL RESEARCH COUNCIL

V. H. BOOTH  
Received *January 29th*, 1959

A RAPID METHOD FOR THE DETERMINATION OF BENZOIC ACID  
IN SOFT DRINKS

PUBLISHED methods for the determination of benzoic acid in soft drinks are generally too time-consuming to be suitable for serial determinations for works control purposes. Existing methods depend on extraction with an organic solvent, such as chloroform<sup>1</sup> or ether,<sup>2</sup> and a double extraction is sometimes necessary to obtain benzoic acid in a sufficiently pure state for subsequent determination.

The increasing use of benzoic acid as a preservative in soft drinks makes desirable a rapid method for its determination for works control purposes. A high degree of accuracy is not so important, as often what is required is the knowledge that benzoic acid has been added to a particular batch, or that it is not present in excess of the legal limit, rather than an exact assessment of the amount present.

It has been found that the amount of benzoic acid present in a concentrate or soft drink can be determined to within approximately 10 per cent. simply by diluting with water, filtering and measuring the optical density of the filtrate at 230 m $\mu$  with an ultra-violet spectrophotometer, another portion of the same batch of material without benzoic acid being used as blank. Without automatic aids, six determinations could be made in 1 hour, and it is estimated that, by "streamlining" the technique, one operator could if necessary carry out at least one hundred determinations in a working day.

## METHOD

## PROCEDURE—

Dilute the sample of compound, squash, etc. with water to give an expected concentration of about 4 p.p.m. of benzoic acid, filter through a 12.5-cm Whatman No. 1 filter-paper, and reject the first 50 ml of filtrate. Collect the subsequent portion of filtrate, and measure its optical density in a 2-cm cell at 230 m $\mu$  with an ultra-violet spectrophotometer. Use as blank another portion of the same batch of compound, squash, etc., containing no benzoic acid, diluted to the same extent and filtered in the same way.

Measure the optical density of a prepared sample of compound, squash, etc. containing a known amount of benzoic acid, and calculate the benzoic acid content of the original sample from the expression  $ax/y$ , in which  $a$  is the concentration of benzoic acid in the prepared sample (parts per million),  $x$  is the optical density of the original sample and  $y$  is the optical density of the prepared sample.

## RESULTS

Different amounts of benzoic acid, as sodium benzoate solution, were added to a sample of Comminuted Orange 2½-fold Compound, which would normally be preserved by the addition of 1500 p.p.m. of benzoic acid. A sample containing 1500 p.p.m. of benzoic acid was taken as reference standard, and the results were as follows—

Benzoic acid added, p.p.m.	.. ..	1100	700	300	150
Benzoic acid found, p.p.m.	.. ..	1151	770	314	165

It should be emphasised that a known benzoic acid concentration in the compound, squash, etc. being analysed must be used as reference standard, as it has been found that not only does the diluted sample have a characteristic absorption of its own at 230 m $\mu$ , but it also has an influence on the absorption of benzoic acid itself at this wavelength, as compared with its absorption in water, even at the same pH.

## REFERENCES

1. Horwicz, W., *Editor*, "Official Methods of Analysis of the Association of Official Agricultural Chemists," Eighth Edition, The Association of Official Agricultural Chemists, Washington, D.C., 1955, p. 487.
2. Nicholls, J. R., "Aids to the Analysis of Food and Drugs," Seventh Edition, Baillière, Tindall and Cox, London, 1952, p. 398.

COUNTIES PUBLIC HEALTH LABORATORIES  
66, VICTORIA STREET  
LONDON, S.W.1

E. ENGLISH

Received March 18th, 1959

## Book Reviews

THE B.D.H. BOOK OF ORGANIC REAGENTS. Tenth Edition. Pp. vi + 182. Poole, Dorset: The British Drug Houses Ltd., B.D.H. Laboratory Chemicals Division. 1958. Price 18s.

This book deals with forty-eight reagents that are used for the detection or determination of elements and, in a few instances, of organic compounds. Each reagent is accompanied by a description of its properties and uses, with details of quantitative methods to which it can be applied; a list of references is appended.

When one considers that the number of new reagents occurring in publications abstracted in *Analytical Abstracts* is well over 100 in a single year and that many of these are claimed to be improvements on those commonly used, it is surprising that many of those mentioned in this book have held their position for so long. Dimethylglyoxime, for instance, has been in use for over 50 years as a reagent for nickel.

One wonders how many references to really valuable reagents are buried in the literature, perhaps because they are not available commercially. This raises the question as to how a new reagent reaches the stage when the manufacturers think it worth while to put it on the market. Presumably organisations such as the publishers of this book depend on tests carried out in their own laboratories and on demands from customers in reaching a decision; they must also be influenced by the cost of production.

While recognising the valuable work done on new reagents in certain laboratories, such as that of Professor Feigl or the University of Birmingham, one wonders whether the Analytical Methods Committee of the Society for Analytical Chemistry might not perform a useful function in examining the claims made for new reagents.

However this may be, this book is invaluable to analysts by providing them in a handy form with useful information on the properties and uses of a number of well-tried reagents.

NORMAN EVERS

CHROMATOGRAPHIE VON STERINEN, STEROIDEN UND VERWANDTEN VERBINDUNGEN. By R. NEHER. Pp. viii + 100. Amsterdam, New York and Princeton: Elsevier Publishing Co.; London: D. Van Nostrand Co. Ltd. 1958. Price 16s.

As the title indicates, this publication is primarily intended for the steroid biochemist, but so wide is its scope that it must inevitably become a *vade mecum* for all whose work touches the steroid field, whether their interest lies in chemical synthesis, biosynthesis or the analysis of natural products. The entire book has already been published in Volume 1 (1958) of the *Journal of*

*Chromatography*, but many will prefer to have it available as this small booklet. Most aspects of the chromatography of steroids on adsorption and partition columns and also on paper chromatograms are covered, approximately half of the material being devoted to the last-mentioned.

The emphasis of the work is on the practical side, extending from the weakly polar monoketones to the strongly hydrophilic cardiac glycosides and steroid glucuronides, yet the material is presented in a logical fashion that provides an excellent theoretical basis for the beginner. The section dealing with the development and interpretation of paper chromatograms is comprehensive, and for those whose knowledge of German is limited there is a unique collection of tabulated information about colour reactions,  $R_f$  and  $R_s$  values of many derivatives in partition systems. As a result of assembling so much information in such limited space, the type is occasionally too small for convenient reading.

One hopes that the author can be persuaded to translate this excellent publication for the wide field of English readers, but in the meanwhile this book in its present form remains an essential for all active workers in the field.

A. E. KELLIE

**GAS CHROMATOGRAPHY.** Edited by VINCENT J. COATES, HENRY J. NOBELS and IRVING S. FAGERSON. Pp. xii + 323. New York and London: Academic Press Inc. 1958. Price \$12.00; 86s.

This book contains the proceedings (both presented papers and discussion) of a symposium on gas chromatography held in Michigan State University in 1957 under the auspices of the Instrument Society of America. The papers presented are under the usual three headings of theoretical treatment, description of apparatus and application to specific analytical problems. By far the most interesting and important paper is by Golay, in which he describes the theoretical and practical development of the coated-capillary column.

The apparatus described includes units capable of operating at temperatures up to 500° C, large-scale columns dealing with up to 10 g of material and commercial units for process analysis. Other papers deal with liquid sampling, integrators, selection of thermistors for katharometers and a combustion device to enhance katharometer sensitivity. The applications range from light to heavy hydrocarbons, chlorofluoro-methanes and ethanes to glycols and ester-type plasticisers.

A. J. P. Martin has contributed an interesting historical survey of the work leading up to the development of gas-liquid chromatography, as well as ideas on the future of the technique.

The book also contains an excellent bibliography, covering all papers published up to the end of 1957, and an author index. This volume gives a reasonable coverage of American work in the field of gas chromatography and is well presented and printed.

A. T. JAMES

**PREPARATION OF SINGLE CRYSTALS.** By W. D. LAWSON, B.Sc., and S. NIELSEN, B.Sc., Ph.D. Pp. viii + 255. London: Butterworths Scientific Publications; New York: Academic Press Inc. 1958. Price 45s.; \$8.80.

At first sight no review of a book with this title might be expected in a journal devoted to analytical chemistry. "This book," the authors state in their preface, "attempts to bring together information on the purification of materials and on the preparation and growth of single crystals having special reference to semi-conductors." Even if the authors had confined themselves to this the analyst is involved, for, in essence, classical analytical techniques are concerned with the preparation of pure and stoichiometric materials. They should therefore be aware of the astounding achievements of recent years in the preparation of materials pure enough to satisfy the requirements of semi-conductor theory and practice. The organic chemist has already made good use of zone-refining technique, and analytical reagents can also benefit.

It is on another count, however, that some mention of this book is justifiable. Chapter 6 is headed "The Chemical Analysis of Semi-Conductors." In this by implication the authors rightly draw attention to the present dilemma; estimates of the nature and magnitude of impurities in semi-conductors have perforce often to be based on electrical measurements, *e.g.*, the Hall coefficient, and they concede that the validity of these estimates is open to doubt. On the other hand the analyst is as yet unable to supply many of the answers. The achievements of the "solid state" physicist compel admiration, and they carry an exciting stimulus and a challenge to the analyst.

The authors would have done well to throw down the challenge and to leave it at that; instead they have sought to outline all the potentialities and possibilities of modern analytical techniques, in 16 pages. It is not clear whom they hoped to inform by such a superficial and unauthoritative

survey; they cannot have failed to irritate those analysts who comprehend the nature of the problems. A glance at the half-page sections devoted to colorimetric analysis and flame photometry will demonstrate the extent of their analytical ignorance and show how they have perhaps laid themselves open to a charge of scientific arrogance. The modern analyst will always be ready to use, where appropriate, physical measurements in place of those of mass and volume on which the craft was nourished, but the "solid state" physicist will do well to realise that analysis and measurement are seldom synonymous and that there is sometimes justification for the old saying—let the cobbler stick to his last.

R. C. CHIRNSIDE

GENERAL BIOCHEMISTRY. By JOSEPH S. FRUTON and SOFIA SIMMONDS. Second Edition. Pp. xii + 1078. New York: John Wiley and Sons Inc.; London: Chapman and Hall Ltd. 1958. Price \$18.00; 144s. 0d.

When reviewing the first edition of this imposing tome—now 4 cm × 15 cm × 23.5 cm in size and weighing over 1.6 kilos—I wrote (*Analyst*, 1954, 79, 112) "I have been able to find few faults with this book. This may, I hope, be taken as evidence that there are few faults to be found with it." Just the same may be said about the second edition with its 128 more pages. The text, moreover, appears to have been completely re-set in slightly bolder and fractionally larger type that makes for yet greater ease of reading, but reduces by little the 14 per cent. increase in length indicated by the number of additional pages.

It would be profitless even to attempt here to list the advances in experimental achievement and resultant knowledge that have made this increase imperative. Naturally they include the complete structure of cyanocobalamin (vitamin B<sub>12</sub>), the Nobel prize-winning work of Sanger and his colleagues whereby we can now set down the complete amino acid sequence and arrangement in the insulin molecule and the hardly less brilliant achievement of du Vigneaud's team at Cornell in making the same thing possible for the polypeptide hormones of the posterior pituitary gland, oxytocin and vasopressin.

Indeed, though every chapter of the 39 in this book registers some more or less spectacular advance, it is perhaps the one on Structure of Proteins that bears clearest witness to the progress made during the years between the appearances of the two editions; this chapter alone has increased in length from 44 to 49 pages.

Other examples, from other chapters, will be found by the large numbers of readers that this book deserves. To cite one only, the single reference and two paragraphs devoted to lipoic acid in the first edition have given place to seven references and a correspondingly larger portion of the text; along with this there has perforce been assembled considerably more information on the biochemical activities of the often closely allied co-enzyme A.

Five years is no longer a big span in the life history of biochemistry, which may to-day claim to be at least 50 years old, yet the advances made during this last 5 years would do credit to a much younger branch of science. That is why the authors of this admirable textbook are particularly to be commended for having kept it up-to-date with less than a 15 per cent. increase in length. The cynic may, however, observe that with this has gone an 80 per cent. increase in price, justified doubtless on the ground that we have here, in spite of its description, what is virtually a first edition of a new textbook, albeit on a subject that has suffered more than most from a plethora of them. It almost seems as if every American university biochemistry department feels an irresistible urge to add yet one more to the list, which contains books showing a wide variety of approaches, from those at sophomore level, often little more than cram books, to the almost encyclopaedic advanced level treatise as enlightening to the non-biochemist as it can be diurnally helpful to the practising biochemist. It is to the latter kind of book that this one belongs, and I consider it the best of the group in the English language. True, it's now pretty expensive even judged by contemporary book prices; all the same I can confidently advise any analyst who is brought into even occasional contact with biochemical problems to unload on to the second-hand market all the biochemical textbooks at present on his shelf (including the first edition of this one) and put whatever financial resources accrue from this action towards buying the new "Fruton and Simmonds," for sooner or later he'll find that he can't afford to be without it. When he has it, he won't need any other.

A. L. BACHARACH

ANALYSIS OF ELECTROPLATING AND RELATED SOLUTIONS. By KENNETH E. LANGFORD. Second Edition. Pp. xvi + 423. Middlesex: Robert Draper Ltd. 1958. Price 60s.

The author of this book is well known for his thoughtful and constructive approach to the problems of control in the electroplating industry, an industry that in the past has been notorious



for its reluctance to consider that the problems even exist. The first edition, which was well received on its appearance in 1951, contained methods of analysis for almost all plating solutions and also gave valuable information on the composition and maintenance of alkaline cleaners and of numerous etches, pickles and dips, which, as the author remarks, invariably receive less attention than the plating solutions themselves. The approach is to the plating foreman and chemist rather than to the skilled analyst, and most of the methods given are gravimetric or volumetric, requiring a minimum amount of special equipment. In keeping with this approach, detailed explanations are given throughout the book of the chemistry involved in the methods described. This second edition contains all the material of the first with an additional 40 pages of new matter.

EDTA was recommended in the first edition for the determination of water hardness, and methods are now given for the use of this reagent in determining zinc, cadmium, nickel and cobalt in plating solutions. Also included are the volumetric determination of fluoride in chromium-plating solutions and the determination of phosphate in cleaning solutions with quinoline (*Analyst*, 1951, 76, 65). There is a new section dealing with pyrophosphate copper solutions and a short description of the principles of the measurement of pH. All this new material adds to the value of the book.

Mr. Langford deals briefly with the examination of plating chemicals, and this section could well have been expanded. Mention could also have been made of the existence of British Standards for most of these chemicals, particularly as these all include methods of analysis.

A criticism of the first edition that the methods given for the determination of impurities in several plating solutions are not sufficiently sensitive (some are indeed only qualitative) is still valid, though references are given to a number of published papers on more sensitive methods.

The book is well produced and contains few misprints. One that has been carried over from the first edition is the use of the word "acid" in Method 38, where "alkali" was intended.

J. W. PRICE

CHROMATOGRAPHISCHE METHODEN IN DER ANALYTISCHEN UND PREPARATIVEN ANORGANISCHEN CHEMIE UNTER BESONDERER BERÜCKSICHTIGUNG DER IONENAUSTAUSCHER. By Priv.-Doz. Dr. Ing. EWALD BLASIUS. Pp. xx + 370. Stuttgart: Ferdinand Enke Verlag. 1958. Price (paper) DM 96; (Cloth boards) DM 99.

The author has been most systematic in his approach to a subject that others have tended to treat in an unselective manner. After an introductory chapter, the remaining nine chapters of the book deal with theoretical and practical aspects of ion exchange, paper chromatography, chromatography on miscellaneous adsorbents, electrophoresis and the use of ion-exchange membranes. The author has achieved a good balance between basic concepts, which are fully treated, and a mass of experimental data on particular separations, which have been well summarised in smaller print and are obviously based on a thorough survey of the large mass of scientific literature on this subject. In the section dealing with paper chromatography, a table of some 29 pages presents fully and clearly a survey of the separations that have been achieved by inorganic paper chromatography. In all but a few special instances, no attempt is made to give numerical  $R_F$  values; instead, the order of movement is given. This is perhaps a more practical method of presentation than is sometimes used, since individual techniques used by different workers often lead to variations in numerical  $R_F$  values, even in what is apparently the same system. Although attention is drawn to the many factors that influence separation patterns achieved with the more complex solvents sometimes used in inorganic chromatography, by the presentation of a complete but much summarised survey, it is to be regretted that no attempt has been made to put into perspective all these effects, some of which achieve greater prominence in the literature than in practice they deserve. An authoritative appreciation of this subject is badly needed.

The 139 illustrations and diagrams are particularly clear and well presented. A comprehensive list of literature references is given at the end of each chapter. It is to be hoped that someone will find the necessary time and enthusiasm to provide an English translation of this extremely valuable book.

R. A. WELLS

HANDBOOK OF CHEMICAL MICROSCOPY. Volume I. By EMILE MONNIN CHAMOT, B.S., Ph.D., and CLYDE WALTER MASON, A.B., Ph.D. Third Edition. Pp. xii + 502. New York: John Wiley & Sons Inc.; London: Chapman and Hall Ltd. 1958. Price \$14.00; 112s.

With the rapidly expanding field of instrumentation available for the detection and determination of small quantities of substances, the value of the microscope in the chemical field tends

to be overlooked. A perusal of this latest edition of Chamot and Mason's book is a reminder that there is probably no physical instrument with such a wide range of usefulness as a well-equipped microscope.

This volume, the third edition of what is now recognised as a standard work, has been thoroughly revised since its last appearance in 1938. The first half of the text is devoted to a description of the microscope and its accessories, the methods of illumination of transparent and opaque objects, the preparation of materials for microscopical study and special methods for interpretation of physical properties. Then come chapters on ultramicroscopy, photomicrography, electron microscopy, the polarising microscope, determination of refractive indices, chemical crystallography, microscopical measurements, particle-size determinations and quantitative analyses of heterogeneous mixtures. Thus a very wide field has been covered; a full list of references supplements the text to assist the reader in pursuing specialised fields of applied microscopy elsewhere. Some special features include electron microscopy for the non-practitioner, optics of illumination, including phase contrast and vertical illumination, and the interpretation of the geometric shapes of crystals with their relationship to optical properties.

The text is thoroughly up-to-date, including references as recent as the middle of 1958. The references themselves are numerous and obviously little of value has been missed; nevertheless, it was noticed that considering the value of the various techniques developed by Wallis for the quantitative analysis of powdered drugs, little space has been devoted to this work. The index is somewhat scanty and could be expanded with advantage.

The lay-out of the text is excellent and the practical instructions, printed in smaller type, are obviously recounted from authoritative experience. The fact that such a large portion of the text is thus allotted indicates that the book will be particularly useful on the bench.

Apart from the valuable information given throughout the text, the book is very readable, in spite of the, to the British reader, maltreatment of the English language with such words as "rendition" and "visualization" to a greater extent than usual in American text. This production can be recommended for the shelves of all practising chemists.

D. C. GARRATT

**POLAROGRAPHY IN MEDICINE, BIOCHEMISTRY AND PHARMACY.** By M. BREZINA and P. ZUMAN.  
Pp. xviii + 862. New York and London: Interscience Publishers Inc. 1958. Price \$19.50; 146s.

This English translation of Brezina and Zuman's monograph on the application of polarography in medicine, biochemistry and pharmacy will be welcomed by a wide circle of polarographers in the western world. The original Czech text, which appeared in 1952, was, despite the baffling language barrier, appreciated in this country for its comprehensive bibliographies and valuable lists of half-wave potentials.

Since there are several reliable texts in English on the theory and practice of polarography, the authors, who are members of Professor Heyrovský's Polarographic Institute in Prague, have devoted the entire volume to the applications of polarographic analysis in the biological sciences. The result is probably the most detailed and carefully documented book on a single aspect of polarography that has yet appeared. Whereas the ground covered is much the same as that in the relevant sections of Kolthoff and Lingane's (Interscience, 1952) and Milner's books (Longmans, 1957), the authors of this book have been able to discuss the work in greater detail, so that a polarographer can operate the various procedures without having to consult the original literature. The subject has been treated critically, and the authors have themselves tested many methods before selecting the best one for detailed description.

The authors have been fortunate with their translator. Professor S. Wawzonek of the University of Iowa, who is the leader of an active school of organic polarography, has done his work so well that it is difficult to realise that we are reading a translation. A comparison of the present volume with the original text reveals the vast amount of editing and rearranging that he has done. The Tables of polarographic data have been revised and expanded and the bibliography extended to include references for 1954. It is, nevertheless, unfortunate that it has not been possible to include more recent references.

The book has been written for use in biochemical research laboratories, clinics and hospitals, but one wonders how much of the detailed information given in this book will be used. For many of the analyses, more specific colorimetric or spectroscopic methods are available and in this country are used in preference to polarographic procedures. On the other hand, there is no doubt that polarography is being used routinely in Czechoslovakia and eastern Europe for many assays that are tackled by other methods in the West. One hopes that a careful perusal of this book by the

staffs of biochemical and clinical laboratories will lead to the dust covers being removed from more polarographs. If this happens, Brezina, Zuman and Wawzonek will have been well rewarded.

J. E. PAGE

**HANDBOOK OF CHEMISTRY AND PHYSICS.** Edited by CHARLES D. HODGMAN, M.S., ROBERT C. WEAST, Ph.D., and SAMUEL M. SELBY, Ph.D. Fortieth Edition. Pp. xxiv + 3456. Cleveland, Ohio: Chemical Rubber Publishing Co. (Distributors in England: Blackwell Scientific Publications Ltd., Oxford.) 1958. Price \$12.00; 100s.

Just because this handbook has run into so many editions, the time may be opportune for a brief survey of its scope. It is divided into sections, which may be described broadly as (i) mathematical, (ii) chemicals, (iii) general chemical tables and properties of matter, (iv) physics and (v) miscellaneous.

The first section, of 333 pages, contains the ordinary mathematical tables, *e.g.*, logarithms (both common and Napierian), trigonometrical functions, reciprocals and, in addition, much other matter such as integrals, hyperbolic functions, statistical tables and trigonometrical formulae.

The section on chemicals accounts for over one-third of the book and is mostly about the physical properties of inorganic and organic compounds, with a separate listing for many of the latter class that are of industrial importance. The data supplied are generally sound; indeed, one not infrequently sees this work cited as an authoritative source. It would, however, be surprising if an occasional error did not creep in, for one reason or another. It will suffice to mention that the refractive index given for 2-phenylethylamine is obviously much too high, and that for benzyl acetate is also on the high side; on the latter, it is only fair to add that it is a figure quoted in other works of reference and appears to date back to Gladstone, but much of what he said in 1884 will not stand comparison with modern values. This section also includes a formula index, lists of melting- and boiling-points (somewhat exasperating to use, though understandably so), a table of isotopes and data on oils, resins, minerals, alloys and plastics.

The general chemical section includes reagents and indicators, solubility data, amino acids, steroid hormones, vitamins, gravimetric factors, thermodynamic constants, densities of aqueous solutions, surface tension and viscosity. The physics section covers heat, hygrometry, electricity, magnetism and light; sound is pianissimo. The major items here are specific heats, vapour pressures, steam tables, dielectrics, X-ray data and emission spectra. The miscellaneous section gives definitions, units and conversion factors, temperature conversion tables, laboratory recipes, photographic formulae, wire tables and astronomical data.

The topics selected for mention above represent only a small proportion of the total. In each edition, some revision in the light of improved modern data is made; among the new items incorporated in this edition are chelating agents, ion-exchange resins, physical constants of rare-earth compounds and of inorganic hydrides and thermodynamic properties of elements and oxides. It is fair to say that there is something here for everybody, but that no one person would need it all.

The use of a thin but reasonably tough paper has allowed the 3500-odd pages to be compressed into occupying but little over 2½ inches of shelf-space, appreciably less than, *e.g.*, the 37th edition, despite a nominal increase of 300 pages.

B. A. ELLIS

**THE CHEMISTRY OF DRUGS.** By NORMAN EVERS, Ph.D., F.R.I.C. and DENNIS CALDWELL, B.Sc., F.R.I.C. Third Edition. Pp. 415. London: Ernest Benn Ltd. 1959. Price 84s.

The first edition of this work appeared in 1926 and the second in 1938. Because of the great changes that have since taken place in therapeutics, the text has been completely re-written. The substances used in medicine are described from the standpoint of their chemical constitutions and laboratory preparation. The emphasis throughout is on chemical structure and the processes of synthesis upon which manufacture is based. For drugs that are still isolated from natural sources, *e.g.*, strychnine, cocaine and colchicine, the discourse is mainly on the structures of the compounds and their syntheses, when they have been achieved.

The book is divided into two parts, the first comprising eighteen chapters on synthetic drugs and the second twenty chapters on naturally occurring organic drugs, the former being divided in accordance with therapeutic action (hypnotics, tranquillisers, antihistamines, etc.) and the latter by their group names, such as ergot alkaloids, glycosidal drugs and steroid hormones.

In the preface to the first edition it is stated that "methods of analysis have been excluded entirely" and, although this is still essentially true, there are a few analytical descriptions, such as

general tests for alkaloids, the thalleioquin test for quinine and colour tests for morphine, which seem redundant and slightly out of place in a book from which analysis is otherwise excluded.

To all who deal with drugs this fully documented volume is useful, because it presents information that, quite often, would otherwise be troublesome to find. Further, there is much reading of considerable interest, and the chapters on non-steroid hormones (63 references), antibiotics (93 references) and vitamins (199 references) appealed to the reviewer as being particularly well planned. Having written this book the authors had good reason to congratulate themselves, but, as though not satisfied, they put yet more hard work into the preparation of the useful Appendix I giving the official or approved name with the corresponding proprietary and chemical name of approximately 550 drugs, and Appendix II, in which the proprietary names are given in alphabetical order. *Finis coronat opus.*

NOEL L. ALLPORT

## Publications Received

- RIVER POLLUTION: I. CHEMICAL ANALYSIS. By LOUIS KLEIN, M.Sc., Ph.D., F.R.I.C., M.Inst.S.P. Pp. x + 206. London: Butterworths Scientific Publications. 1959. Price 30s.
- HETEROCYCLIC CHEMISTRY. By ADRIEN ALBERT, Ph.D., D.Sc., F.R.I.C. Pp. x + 424. London: The Athlone Press, University of London. 1959. Price 45s.
- BRITISH STANDARDS INSTITUTION YEARBOOK 1959. Pp. iv + 542. London: British Standards Institution. 1959. Price 15s.
- THEORETICAL ORGANIC CHEMISTRY. Papers presented to the Kekulé Symposium organised by the Chemical Society, London, September, 1958. Pp. xviii + 298. London: Butterworths Scientific Publications for International Union of Pure and Applied Chemistry (Section of Organic Chemistry). 1959. Price 50s.
- DIFFERENTIAL THERMAL ANALYSIS AS APPLIED TO BUILDING SCIENCE. By V. S. RAMACHANDRAN and S. P. GARG. Pp. viii + 182. Roorkee, India: Central Building Research Institute. 1959. Price Rs. 5.00.  
*An annotated bibliography.*
- PRECIPITATION FROM HOMOGENEOUS SOLUTION. By LOUIS GORDON, MURRELL L. SALUTSKY and HOBART H. WILLARD. Pp. viii + 188. New York: John Wiley & Sons Inc.; London: Chapman & Hall Ltd. 1959. Price \$7.50; 60s.
- SMOKING: THE CANCER CONTROVERSY. By SIR RONALD A. FISHER, Sc.D., F.R.S. Pp. 48. Edinburgh and London: Oliver & Boyd Ltd. 1959. Price 2s. 6d.
- THE PRINCIPLES OF HUMANE EXPERIMENTAL TECHNIQUE. By W. M. S. RUSSELL, M.A., D.Phil., and R. L. BURCH. Pp. xiv + 238. London: Methuen & Co. Ltd. 1959. Price 30s.
- READING GERMAN FOR SCIENTISTS. By HANS EICHNER, B.A., Ph.D., and HANS HEIN, B.A. Pp. xii + 207. London: Chapman & Hall Ltd. 1959. Price 30s.
- METHODS OF BIOCHEMICAL ANALYSIS. Volume VII. Edited by DAVID GLICK. Pp. x + 353. New York and London: Interscience Publishers Inc. 1959. Price \$9.50; 72s.
- SOURCE MATERIAL FOR RADIOCHEMISTRY. By the Subcommittee on Radiochemistry of the Committee on Nuclear Science. Pp. 24. Washington, D.C.; National Academy of Sciences-National Research Council. 1959.  
*Nuclear Science Series, Report Number 27.*

## REPORTS OF THE ANALYTICAL METHODS COMMITTEE:

### REPRINTS

Two Reports prepared by the Metallic Impurities in Organic Matter Sub-Committee, "The Determination of Lead," reprinted from *The Analyst*, March 1959, **84**, 127-134, and, "Notes on Perchloric Acid and its Handling in Analytical Work," reprinted from *The Analyst*, April 1959, **84**, 214-216, are now available from the Secretary, The Society for Analytical Chemistry, 14 Belgrave Square, London, S.W.1; price to members, 1s. 6d. each; to non-members, 2s. 6d. each.

Reports of the Analytical Methods Committee are only available from the Secretary (not through Trade Agents) and remittances, made out to the Society for Analytical Chemistry, MUST accompany orders.

**CLASSIFIED ADVERTISEMENTS**

*The rate for classified advertisements is 5s. a line (or space equivalent of a line), with an extra charge of 1s. for the use of a Box Number. Semi-displayed classified advertisements are 60s. per single-column inch.*

**A**NALYST back volumes and sets wanted to buy for cash, Also other scientific journals. Write to A. Ashley, 27, East 21 Street, New York, 10, N.Y., U.S.A.

**BRITISH TITAN PRODUCTS COMPANY LIMITED**  
has vacancies for

**CHEMISTS**

in its Research Laboratories at  
Billingham, Co. Durham.

The Company is primarily concerned with the large scale manufacture of Titanium Dioxide and is characterised by a considerable expansion in post-war years. This continuing development is associated with a multiplicity of physical and inorganic chemical problems which can provide an interesting and worthwhile job in well equipped laboratories and pilot plants.

Applications are invited from Graduates with good honours degrees for the above vacancies. Some industrial experience is desirable, but not essential. Salaries and prospects are very attractive for men with the right qualities: conditions of work are good: a Staff Bonus, Superannuation Scheme and Non-contributory Life Assurance are in operation: housing assistance is available if required.

Applications will be treated in the strictest confidence and should be addressed to the Personnel Manager, British Titan Products Company Limited, Billingham, Co. Durham, quoting Reference S.1.

**M**ICRO-ANALYST required to take charge of a laboratory performing elemental analysis of organic compounds at Chesterford Park Research Station, near Saffron Walden, Essex. Sound knowledge of general techniques and practical experience essential. Five day week. Good canteen facilities. Lodging accommodation arrangeable. Full particulars and salary expected to Personnel Manager, Fisons Pest Control Limited, Harston, Cambridge, quoting Reference No. 1483.

**P**UBLIC ANALYST requiring DEPUTY invites applications for post of Senior Assistant from persons having the necessary qualifications. Branch E certificate essential. Salary will be commensurate with qualifications and experience and the post offers excellent prospects for quick advancement.

Applications to Dr. H. K. Lawton, F.R.I.C., Room 74, 16 Donegall Square South, Belfast, Northern Ireland, from whom further particulars may be obtained.

**P**UBLIC ANALYST (Midlands) wants Fellow (Branch E) with view to Deputy-ship. Must be well experienced in the work of a public analyst. Excellent opportunity for a keen, energetic man. Apply Box No. 3994, The Analyst, 47 Gresham Street, London, E.C.2, giving particulars of age, experience, present salary, etc.

**F**.R.I.C. (Branch E) required. Assistant with a view to early partnership in old and well established practice. Some living accommodation available if required. Write immediately, giving the names of two referees, to Box No. 3993, The Analyst, 47 Gresham Street, London, E.C.2.

**S**ENIOR SCIENTIFIC OFFICERS (a): SCIENTIFIC OFFICERS (b). Pensionable posts for men or women in all major scientific fields, including physics, chemistry, mineralogy, biology, forensic science, meteorology and mathematics. Age limits: (a) at least 26 and under 31, (b) at least 21 and under 28. Extension for regular Forces Service and Overseas Civil Service. Qualifications: normally first or second class honours degree in science, mathematics or engineering, or equivalent attainment; additionally for (a), at least 3 years' relevant (e.g. post-graduate) experience. London salaries (men): (a) £1,233-£1,460, (b) £655-£1,150; provision for starting pay above minimum. Promotion prospects. Write Civil Service Commission, 17 North Audley Street, London, W.1. for application form, quoting (a) S53/59, (b) S52/59.

**L**ABORATORY ANALYST required by NIGERIA EASTERN REGION (Ministry of Agriculture) on contract for 2 tours of 12/24 months each in first instance. Salary scale (including inducement pay) £840 rising to £1,530 a year. Gratuity at rate of £100/150 a year. Commencing salary according to age and experience. Outfit allowance £60. Free passages for officer and wife. Assistance towards children's passages and grant of up to £150 annually for their maintenance in U.K. Liberal leave on full salary. Candidates, between 22 and 55, preferably with a suitable diploma or degree in Chemistry, must have experience in analytical work and be capable of extremely accurate work under minimum supervision. Duties will include routine analysis of soil samples and some field work. Write to the Crown Agents, 4, Millbank, London, S.W.1. Stage age, name in block letters, full qualifications and experience and quote M3C/52549/AAD.

**INSTITUTE OF CANCER RESEARCH:**

Royal Cancer Hospital, Chester Beatty Research Institute, Fulham Road, S.W.3.

**T**ECHNICIAN required for Physical Chemistry Laboratory. Experience with spectroscopic techniques an advantage. The post is permanent and superannuable; salary according to qualifications and experience. Applications, with names of two referees, to the Secretary, 33 Sumner Place, S.W.7, quoting reference 301/B/7, before August 21st.

**A**SSISTANT ANALYST required by Imperial Chemical Industries Limited, Paints Division, Slough. Preference will be given to candidates who have H.N.C. or Gen.B.Sc. or who have experience in analytical work in the Paint, Plastics or allied industries, but candidates who have good general analytical experience without these specific qualifications of experience will be considered. A knowledge of modern instrumental techniques of analysis is desirable. Upper age limit 35. Pension Fund, Five-day week and excellent recreational facilities. Applications giving brief details of experience and/or qualifications should be made in writing to the Staff Officer, I.C.I. Limited, Paints Division, Wexham Road, Slough, Bucks.

**GOVERNMENT OF NORTHERN IRELAND  
CIVIL SERVICE COMMISSION**

Applications are invited for two permanent and pensionable posts of Scientific Officer in the Department of Industrial and Forensic Science, Ministry of Commerce.

- (1) Biologist, with botany as a principal subject.
- (2) Chemist. For this post a knowledge of pharmacy or food and drugs would be an advantage.

For both posts an appropriate first or second class honours degree or an approved equivalent qualification is required. Salary scale £635-£1,120. Entry point will be determined according to the qualification and experience of the successful candidates. Preference for ex-Servicemen.

Further particulars and application forms obtainable from the Secretary, Civil Service Commission, Stormont, Belfast, should be returned by 2nd September, 1959.

**BINDING**

Have your back numbers  
of The Analyst bound in  
the standard binding case

Send the parts together  
with a remittance for 12/6

to:

**W. Heffer & Sons Ltd**  
**Hills Road Cambridge**



**GREEN'S PURE  
FILTER PAPERS**

Made since 1915

Have you met Green's 9047.

Very rapid, of enormous wet strength and resistant to acids and alkalis.

Write for price list MG.  
and free samples.

**J. BARCHAM GREEN LTD**  
Maidstone                      England

**ANALOID REAGENTS  
FOR  
METALLURGICAL ANALYSIS**

A range of compressed chemicals specially prepared for the Analoid System of Analysis.

Full particulars and an outline of all methods supplied on request.

**RIDSDALE & CO. LTD.**  
**NEWHAM HALL, MIDDLESBROUGH**

**NEW  
BRITISH CHEMICAL STANDARDS**

No. 280 Low Carbon Ferro-Manganese  
No. 208/1 High Carbon Ferro-Manganese  
No. 181/1 4% Cu Aluminium Alloy to  
BS 1490: LM14  
No. 182/1 11% Si Aluminium Alloy to  
BS 1490: LM20

Full particulars in list No. 395  
free on request from

**BUREAU OF ANALYSED SAMPLES LTD**  
**NEWHAM HALL, MIDDLESBROUGH**

**HEFFER'S  
OF CAMBRIDGE**

are always glad to buy

**SCIENTIFIC  
JOURNALS**

especially complete sets and

runs of

**THE ANALYST**

also scientific and technical  
libraries, early books, books  
on the history of science,  
etc.

**W. HEFFER & SONS**

Limited

**Petty Cury, Cambridge**

England

Analysing organic compounds?

Relax!...

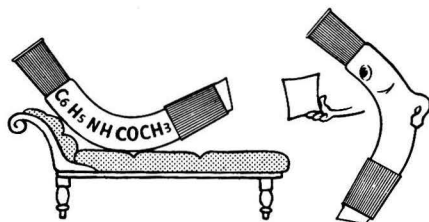

LOUGHBOROUGH GLASS HAVE THE ANSWER

Here are three ways of solving your problems

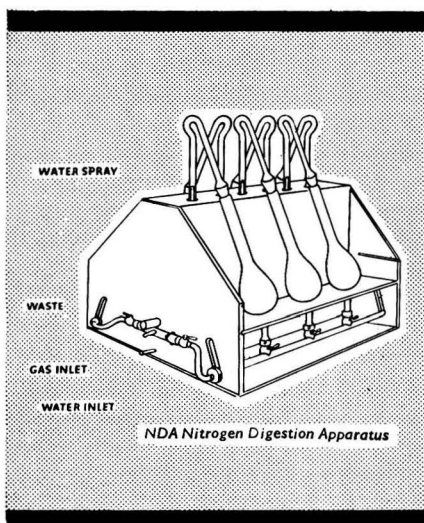

#### ◀ NDA—Nitrogen Digestion Apparatus

This is for nitrogen estimation according to Kjeldahl. Compact, portable, needs no fume cupboard and will carry out multiple digestions wherever there are gas, water and waste connections.

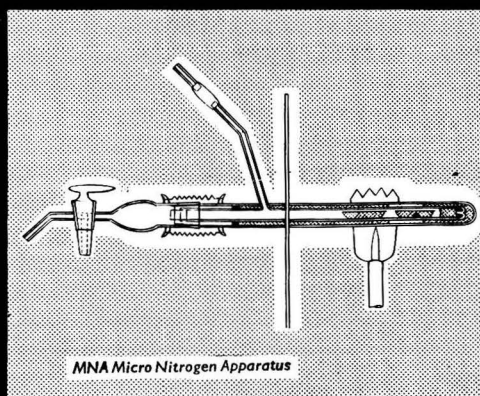

#### MNA—Micro Nitrogen Apparatus ▶

A novel assembly—also for determining nitrogen content, but this time by the Dumas and Pregl method. Small quantities—quick answers.

#### MCA—Micro Combustion Apparatus

A first cousin to MNA, but more general in purpose. A new design for the rapid combustion of organic compounds, including volatile ones.

FULLER INFORMATION FROM :



LOUGHBOROUGH GLASS COMPANY LTD., LOUGHBOROUGH, LEICS

Telephone: Loughborough 4881 Telegrams: Glass-Telex-Loughborough Telex: 34/629

(R1)

**STANTON'S**

NEW 1959 CATALOGUE  
is your complete  
guide to  
precision balances



HERE'S A SELECTION YOU  
CAN'T AFFORD TO MISS

Our new catalogue is  
more informative than our  
press advertisement.  
A DEMONSTRATION  
will be more convincing  
than either.

*A postcard will bring a technical  
representative to your laboratory.*

*Guaranteed*  
**STANTON PRECISION**  
1  
**BALANCES**



**STANTON INSTRUMENTS LTD.,**  
119, Oxford Street, London, W.1.  
Telephone: 7533/4

*New Feature—* Set of weights included

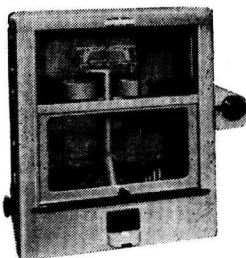
**STANTON A49**

Already one of the most popular balances in our range. A set of five weights from 10-100 g is now built into the case on a small turntable adjacent to the pan, for greater convenience and quicker weighing.

Capacity 200 g. Sensitivity 0.1 mg.

*New Features—*

**Vernier Scale—  
Partial Release**

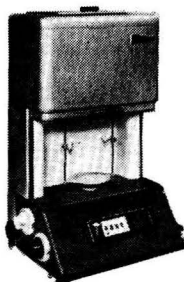
**STANTON  
ULTRAMATICS**

Four models now available, all incorporating facilities for tare weighing and partial release. New numbered Vernier Scales on Models U.M.3 and U.M.10 for greater convenience and quicker weighing.

Capacity 200 g. Sensitivities 0.1 mg—1 mg.

*New Feature—* Twin Bankweight Loading

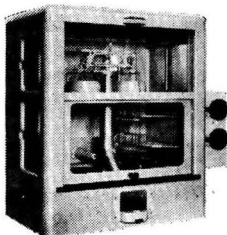
**STANTON B20**

A worthy successor to Britain's first full Weight-loading Balance, this model now incorporates a new graticule and twin bank weigh-loading, for greater convenience and quicker weighing.

Capacity 200 g. Sensitivity 0.1 mg.

*And still the best value obtainable—*

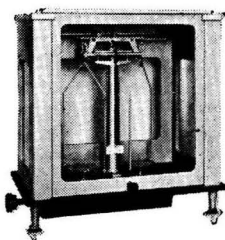
**STANTON C26**

A firm favourite in schools and University Laboratories where accuracy, dependability, and robustness are the key requirements.

Capacity 200 g. Sensitivity 0.1 mg.



**Erwinia Chrysanthemi:**  
A plant pathogen causing Stem  
Rot in Chrysanthemums and  
Soft Rot in fleshy vegetables



a

cure

for

# chrysanthemums

When your business is selling Chrysanthemums, Stem Rot can be disastrous. Faced with this menace a certain large firm of growers turned to us. The problem was to isolate infected cuttings early enough to prevent cross infection in the Nursery.

Now, in this one business alone upwards of a million cuttings a year are being laboratory tested in Oxoid Culture Media before rooting, to eradicate infected stock.

FOR PROGRESSIVE LABORATORIES



CULTURE MEDIA

The use of Oxoid Culture Media ensures constant quality and uniformity in your laboratory technique. Absolutely reliable, quick, convenient and economical, Oxoid Culture Media are available in tablet or granular form. Full details from:

OXOID DIVISION OF OXO LTD., Thames House,  
Queen Street Place, London, E.C.4 (CENTRAL 9781)



## PLATINUM LABORATORY APPARATUS

Our comprehensive standard range of Platinum Laboratory Apparatus, manufactured by skilled craftsmen from materials of the highest purity, has been compiled to assist users in selecting what is most suited to their needs. In cases where a catalogued specification fails to meet requirements, we will gladly manufacture in accordance with customers' own designs.

★ Users are invited to avail themselves of our REPAIR AND EXCHANGE SERVICE.

*Literature forwarded on application. Technical representatives are always available for consultation and advice.*

**ENGELHARD INDUSTRIES LTD.**

BAKER PLATINUM DIVISION

52, HIGH HOLBORN · LONDON · W.C.1. CHAncery 8711

## THE LABORATORY GLASSBLOWERS COMPANY

COMPLETE LABORATORY FURNISHERS

PRESENTS:—

### THE WATSON MARLOW AIR FLOW INDUCER

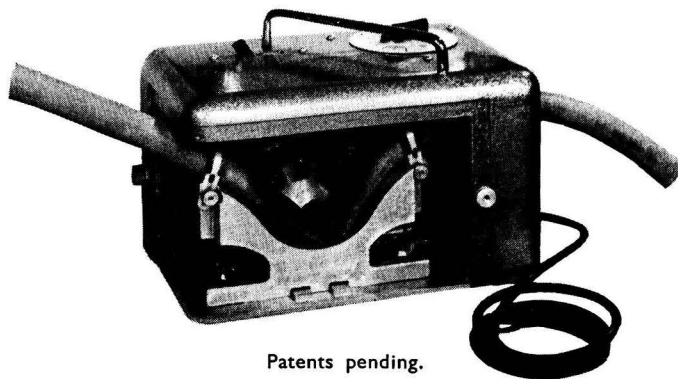

Patents pending.

The Fluid, any fluid, flows through the pipe and nothing else.

FULL PARTICULARS AND PRICE ON APPLICATION.

**THE LABORATORY GLASSBLOWERS CO., VALLEY WORKS,  
LANE END ROAD, SANDS, HIGH WYCOMBE, BUCKS.**

TELEPHONE HIGH WYCOMBE 2419

# QUICK

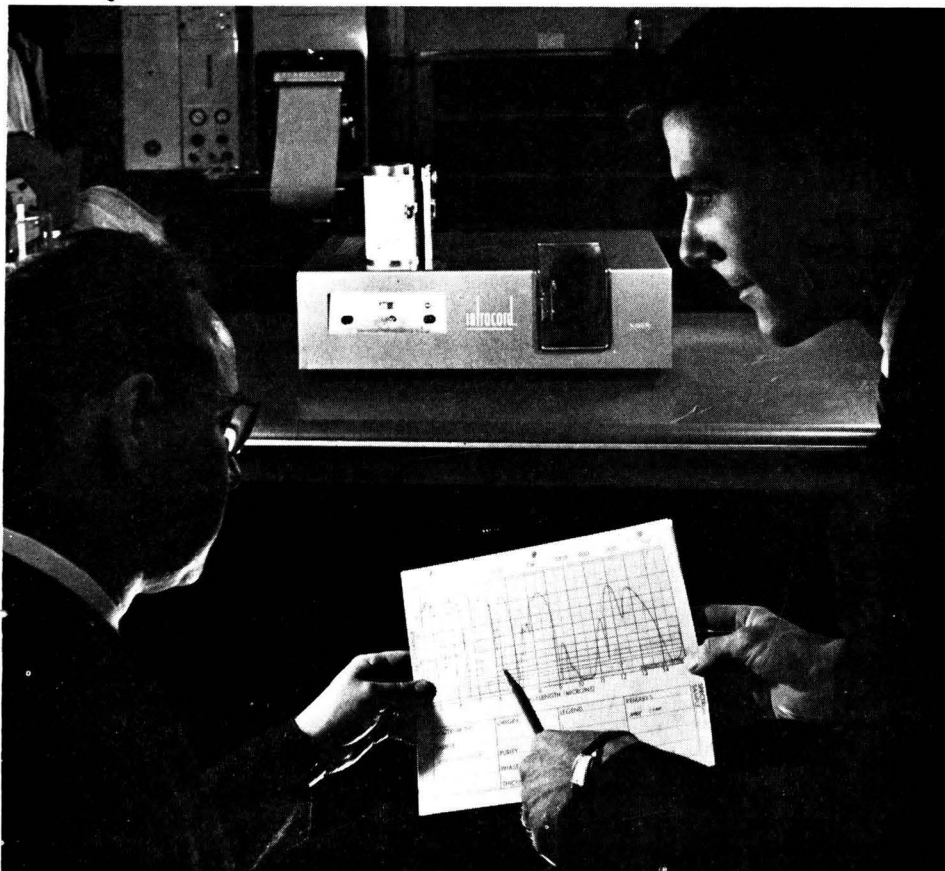

Perkin-Elmer's Infracord is a versatile Infrared Spectrophotometer, giving a qualitative spectrum in a minute. The Infracord is particularly compact, easy and quick in use, and not costly. We should like to send you full details.

#### **Infracord (Model 137)**

Robust. Reliable. Only three controls.  
Wavelength range: 2.5—15 $\mu$ . Reproducibility:  $\pm$  0.01 $\mu$   
*Another version of the Infracord, fitted with a KBr prism, covers the wavelength range 12.5—25 $\mu$ .*

Double-beam, aspherical optical system  
Manual setting of drum—no run-back time  
Fully automatic operation  
Size: 27 $\frac{1}{2}$ " x 17" x 8 $\frac{1}{2}$ " (70 x 43 x 22 cm)  
Price: £1410      Made in Great Britain

## Perkin-Elmer

ANALYTICAL  
INSTRUMENTS

160 Cheapside, London EC2 · Telephone MONarch 8177

ALWAYS SPECIFY



FOR PRECISION-PERFORMANCE-PRICE

Standard Ovens, Baths and Incubators are offered to prospective purchasers on one month's test approval.

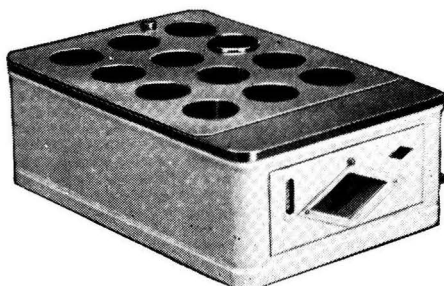

Universal Water Bath

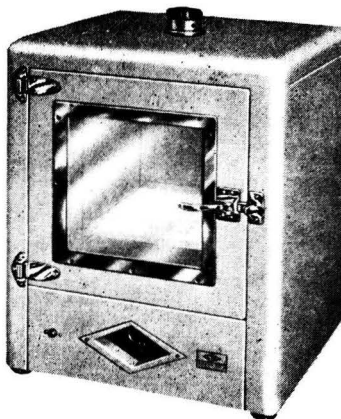

Type F. Oven with glass panel door

## LABORATORY THERMAL EQUIPMENT LTD.,

GREENFIELD. NEAR OLDHAM. ENGLAND - Tel. SADDLENORTH 2788

### CONFIDENCE IN



**READINGS**

WITH

## JOHNSON TEST PAPERS

Johnson Universal and Comparator Test papers are universally accepted for their accuracy.

Universal Test Papers will give the pH value of any solution to within 0.5 pH in the range of 1 to 10.

Comparator Test Papers give even greater accuracy. They indicate values from 3.6 to 10 pH in steps of 0.3 pH. Comparator Paper No. 1035 determines pH values from 1.0 to 3.5 in steps of 0.5 pH. Johnsons also supply Litmus papers and an extensive range of other Indicator papers for specific uses in Science and Industry. Write for leaflet.

**JOHNSONS OF HENDON LTD.**  
LONDON, N.W.4



# 910

This, of course, refers to Eastman 910 — a new adhesive of special properties for special applications. Eastman 910 will bond almost any surface to another with the exception of polythene and fluon.

It has the following advantages:

1. **Rapid set time.** This varies from seconds to minutes, depending on the surfaces bonded.
2. **Versatility.** It has a very wide range of applications.
3. **Easy handling.** A one component adhesive, no mixing is required prior to application.
4. **Minimum internal stress.** No solvent to evaporate, no heat or excessive pressure required. Shrinkage is of very low order and so minimum residual stress is built up within the adhesive film.

For further information write to:

**KODAK LTD.**  
**KIRKBY, LIVERPOOL**  
Telephone: Simonswood 2977/8

## FOR IMMEDIATE pH MEASUREMENT

The Philips PR.9400 Direct-reading pH Meter is mains-operated and can be used for all pH, redox-potential measurements and potentiometric titrations, including measurements in earthed liquids. Other important advantages of the Philips PR.9400 are current-less measurement on three pH ranges, electrical zero-point at pH7 and provision for the attachment of continuous recording and control instruments. It may be used as a high resistance D.C. millivoltmeter. Both glass and calomel electrodes are available.

**Specification :**

- Measuring ranges: pH 0-6, 3-9, 8-14
- Sensitivity: Better than 0.01 pH
- Reproducibility: 0.01 pH
- Measuring accuracy: max. 0.02 pH
- Reading accuracy: 0.01 pH
- Stability: Better than .02 pH per 24 hours
- Temperature correction: 0-100°C
- Meter: Moving coil, class 0.5%

Made by N. V. Philips Eindhoven, for Philips Electrical Ltd.  
 "Philips" is the registered trade mark of Philips Electrical Ltd.  
 Sole Distributors in U.K.

**RESEARCH & CONTROL INSTRUMENTS LTD.,**  
 Instrument House, 207 King's Cross Road, London, W.C.1. Tel. Terminus 8444

(RCLO428)

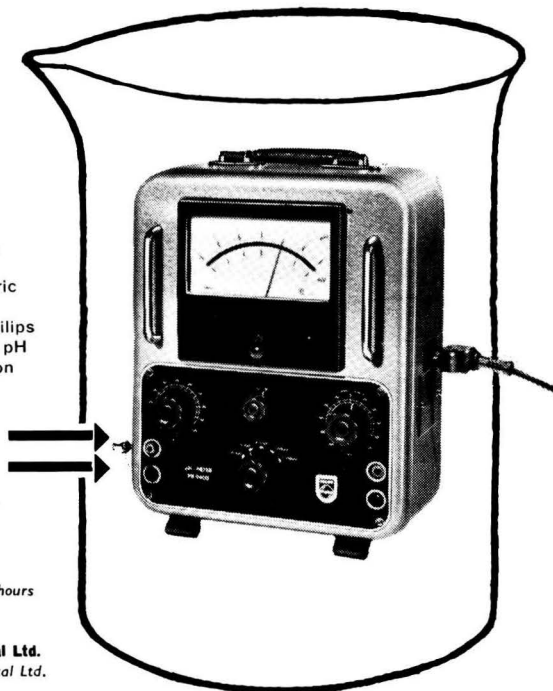

**reagents for**

**GAS**

**CHROMATOGRAPHY**

In order to provide uniform supplies over a period of years B.D.H. have specially purified large quantities of stationary phase materials for gas chromatography, which are now held in stock as single batches. The following materials, characterised by the description 'for gas chromatography', are available:

	Recommended Working Temperature
BENZYL-DIPHENYL	80° - 150°C
DIETHYL-DIGOL ( <i>ethyl carbitol; diethylene glycol diethyl ether</i> )	Room Temperature
DIGLYCEROL	20° - 100°C
DIMETHYL SULPHOLANE	Room Temperature
DINONYL PHTHALATE	20° - 100°C
FORM-DIMETHYLAMIDE ( <i>dimethyl-formamide</i> )	-20° - 20°C
n-HEXADECANE	20° - 50°C
2:6:10:15:19:23-HEXAMETHYL-TETRACOSANE ( <i>squalane</i> )	20° - 150°C
TRITOLYL PHOSPHATE ( <i>tricresyl phosphate</i> )	20° - 150°C

'Celite' for gas chromatography, prepared from 'Celite' 545 and washed and redried after grading to remove occluded dust, is issued in 100 g bottles in the grades of 30-80 and 80-120 mesh.

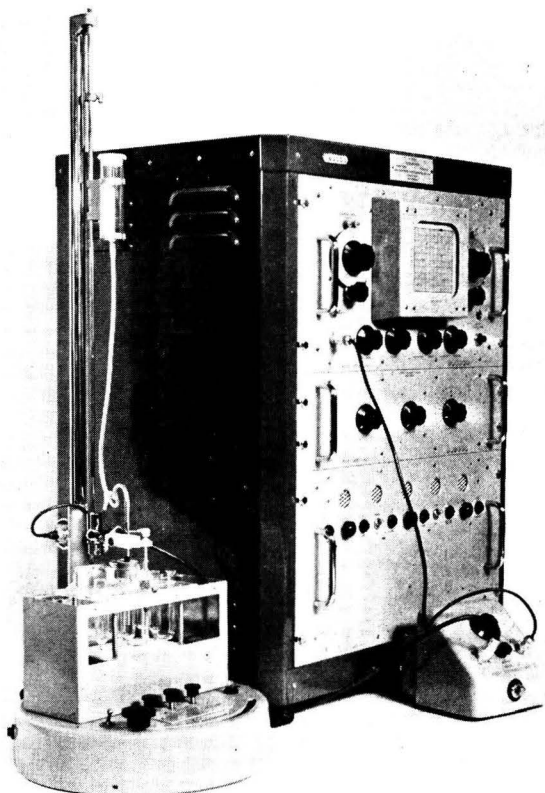

## progress in polarography

- ★ Speedy, direct or derivative operation
- ★ Direct reading from scale eliminates geometrical construction
- ★ Greater resolution due to formation of Peaked Polarograms
- ★ Polarograms reproduced every seven seconds
- ★ Increased sensitivity enables accurate determinations at concentrations of fractions of a microgram per millilitre

## with the *cathode ray* polarograph

you have the ultimate in Polarographic technique, without undue complexity of control. Suitable for research or routine, it is supplied complete with its Electrode Stand, which includes a thermostatically controlled tank, provision for simultaneous degassing of the three cells and easy means of raising and lowering the electrode in the solutions under test. Camera attachments are also available. We offer an applications advisory service together with demonstrations on your own samples.

## SOUTHERN INSTRUMENTS

ANALYTICAL INSTRUMENTS DEPT. OF SOUTHERN INSTRUMENTS LTD., CAMBERLEY, SURREY  
Telephone: CAMBERLEY 3401 (7 lines)

---



### PORTABLE pH METER CAT. No. 11071

The new Pye Portable pH Meter is completely self-contained, with batteries, direct-reading meter and accessories. The front of the right hand compartment drops down to provide an electrode stand. The sheathed electrode assembly, however, can be carried in the hand when it is required to take on the spot dip tests.

A four valve amplifier with a large degree of negative feedback enables a robust meter movement to be used and provides exceptional linearity and stability of calibration. The input stage uses an electrometer type of valve which reduces errors due to grid current and input conductance to a very low order. All valves are robust sub-miniature types giving maximum immunity from mechanical shock and very low power consumption. Consumption is balanced between batteries to equalise battery life and to ensure that the very low battery drain is used to the greatest advantage.

The instrument is contained in a resin-sealed hardwood case, which has been specially treated against acids and other corrosives.



### PYE UNIVERSAL pH METER CAT. No. 11067

The Pye Universal pH Meter combines extreme accuracy, stability and simplicity of operation. The reading is given directly on a large meter of scale length  $4\frac{1}{2}$  inches. The range is 0-8 and 6-14pH units; each division is 0.1pH and readings can be estimated to 0.01pH. Millivolt ranges can also be selected: 0-800 and 600-1400mV.

Normally there are only two controls to adjust each day and the readings are almost entirely unaffected by wide mains supply variations. Zero stability is  $\pm 0.02$ pH for mains voltage variations of  $\pm 15$  per cent and frequency variations of  $\pm 3$ c/s. Circuit accuracy is such that the response is stable and linear to  $\pm 0.1\%$  under the above conditions of mains variation. Instrument sensitivity is 100 microamps/pH and external indicators and controllers can be plugged in without disturbing the panel meter. A total resistance up to 10 kilohms may be used. Both automatic and manual slope correction over the range 0-100°C is provided.

A versatile electrode kit is supplied and a wide range of pH electrodes is also manufactured for special application.



SCIENTIFIC  INSTRUMENTS

*Please write for our new leaflets.*

**W. G. PYE & CO. LTD.,**

**GRANTA WORKS, NEWMARKET RD., CAMBRIDGE.**

Tel: Cambridge 54411.

Grams: Pye, Cambridge

# THE ANALYST

THE JOURNAL OF THE SOCIETY FOR ANALYTICAL CHEMISTRY

## CONTENTS

	Page
Proceedings of the Society for Analytical Chemistry .. .. .	401
<b>ORIGINAL PAPERS</b>	
A Modified Hydroxamic Acid Method for Determining Total Esterified Fatty Acids in Plasma—D. M. Morgan and K. J. Kingsbury .. .. .	409
The Determination of Small Amounts of $\alpha$ -Picoline in Pyridine by a Solution-temperature Method—K. A. Adey and J. D. Cox .. .. .	414
A Method for the Rapid Detection of Small Concentrations of Organic Bases in Urine—P. J. Morgan .. .. .	418
The Determination of DDT Residues in Foodstuffs—G. A. Sergeant and R. Wood .. .. .	423
The Determination of Boron in Plain-carbon and Alloy Steels—J. Borrowdale, R. H. Jenkins and C. E. A. Shanahan .. .. .	426
The Determination of Tin in Iron and Alloy Steels—A. I. Williams .. .. .	433
The Determination of Oxygen in Titanium - Manganese Alloys—D. F. Wood and J. A. Oliver .. .. .	436
The Determination of Tungsten as Tristri- <i>n</i> -butylammonium I2-Tungstophosphate—C. C. Miller and D. H. Thow .. .. .	440
Raman Spectra in Spectrofluorimetry—C. A. Parker .. .. .	446
<b>NOTES</b>	
The Additive Effect of Substituent Groupings on the Chromatographic Behaviour of Phenoxacetic Acids—L. S. Bark and R. J. T. Graham .. .. .	454
The Separation and Colorimetric Determination of Cobalt in Presence of Copper and Nickel—W. D. Duffield .. .. .	455
The Non-aqueous Titration of Phenolic Hydroxyl—E. J. Greenhow and J. W. Smith .. .. .	457
The Use of Gas Chromatography for Determining Water in Pharmaceutical Preparations—D. A. Elvidge and K. A. Proctor .. .. .	461
A Field Method for the Determination of Phosgene—B. E. Dixon and G. C. Hands .. .. .	463
The Extraction of Pigments from Plant Material—V. H. Booth .. .. .	464
A Rapid Method for the Determination of Benzoic Acid in Soft Drinks—E. English .. .. .	465
Book Reviews .. .. .	466
Publications Received .. .. .	472
Reports of the Analytical Methods Committee: Reprints .. .. .	472