

# The ANALYST

A Monthly Publication  
dealing with all branches  
of Analytical Chemistry:  
the Journal of the Society  
for Analytical Chemistry

Published for the Society by  
W. HEFFER & SONS LTD., CAMBRIDGE

**Volume 84**

**No. 999, Pages 329-400**

**June 1959**

# THE ANALYST

THE JOURNAL OF THE SOCIETY FOR ANALYTICAL CHEMISTRY

---

## PUBLICATION COMMITTEE

Chairman: K. A. Williams

### Members:

N. L. Allport  
A. L. Bacharach  
B. A. Ellis, O.B.E.  
D. C. Garratt  
J. H. Hamence

J. Haslam  
H. M. N. H. Irving  
W. C. Johnson, M.B.E.  
J. I. M. Jones  
E. Q. Laws

R. F. Milton  
J. G. Sherratt  
L. S. Theobald  
T. S. West  
D. W. Wilson

and the President and Honorary Officers

President of the Society: R. C. Chirnside

Hon. Secretary of the Society:  
R. E. Stuckey

Hon. Treasurer of the Society:  
A. J. Amos

Hon. Assistant Secretaries of the Society:  
L. Brealey; S. A. Price

### Editor:

J. B. Attrill, M.A., F.R.I.C.

14 BELGRAVE SQUARE, LONDON, S.W.1

Telephone: BELgravia 3258

### Assistant Editor:

P. W. Shallis

---

## NOTICE TO SUBSCRIBERS

(Other than Members of the Society)

All subscriptions to *The Analyst*, including *Analytical Abstracts*, should be sent through a Bookseller or direct to

W. HEFFER & SONS LTD., CAMBRIDGE, ENGLAND

Subscriptions are NOT accepted for *The Analyst* alone

Subscriptions to *The Analyst*, together with *Analytical Abstracts* printed on one side of the paper (without index), can be accepted at £8 15s. per annum.

Subscriptions to *The Analyst*, together with *Analytical Abstracts* printed on one side of the paper (with index), can be accepted at £9 12s. 6d. per annum.

N.B.—Members send their subscriptions to the Hon. Treasurer.

Single Copies Price 15s. Post Free

Subscription Rate, inclusive of *Analytical Abstracts* and Indexes, £8 8s. per annum, post free.

Volume 84, No. 999

June 1959

Analysing organic compounds?

Relax!...

LOUGHBOROUGH GLASS HAVE THE ANSWER

Here are three ways of solving your problems

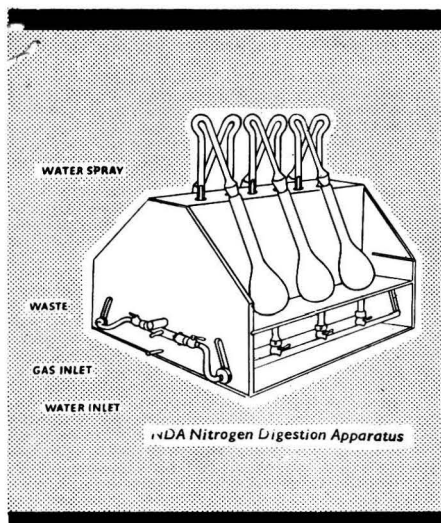
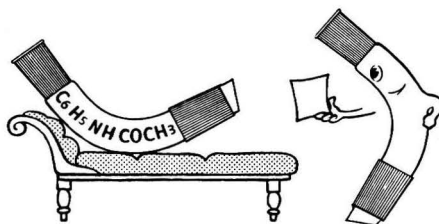

#### ◀ NDA—Nitrogen Digestion Apparatus

This is for nitrogen estimation according to Kjeldahl. Compact, portable, needs no fume cupboard and will carry out multiple digestions wherever there are gas, water and waste connections.

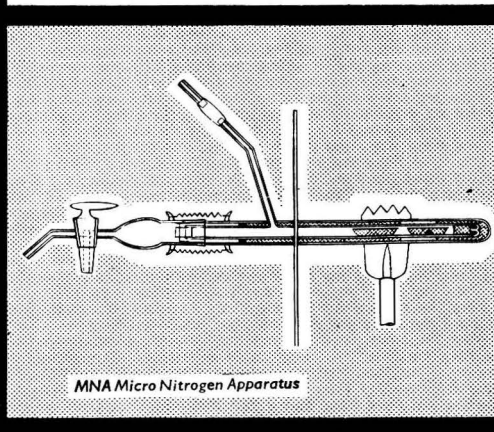

#### MNA—Micro Nitrogen Apparatus ▶

A novel assembly—also for determining nitrogen content, but this time by the Dumas and Pregl method. Small quantities—quick answers.

#### MCA—Micro Combustion Apparatus

A first cousin to MNA, but more general in purpose. A new design for the rapid combustion of organic compounds, including volatile ones.

FULLER INFORMATION FROM :



LOUGHBOROUGH GLASS COMPANY LTD., LOUGHBOROUGH, LEICS

Telephone: Loughborough 4881    Telegrams: Glass-Telex-Loughborough    Telex: 34/629

(R1)



### PORTABLE pH METER CAT. No. 11071

The new Pye Portable pH Meter is completely self-contained, with batteries, direct-reading meter and accessories. The front of the right hand compartment drops down to provide an electrode stand. The sheathed electrode assembly, however, can be carried in the hand when it is required to take on the spot dip tests.

A four valve amplifier with a large degree of negative feedback enables a robust meter movement to be used and provides exceptional linearity and stability of calibration. The input stage uses an electrometer type of valve which reduces errors due to grid current and input conductance to a very low order. All valves are robust sub-miniature types giving maximum immunity from mechanical shock and very low power consumption. Consumption is balanced between batteries to equalise battery life and to ensure that the very low battery drain is used to the greatest advantage.

The instrument is contained in a resin-sealed hardwood case, which has been specially treated against acids and other corrosives.

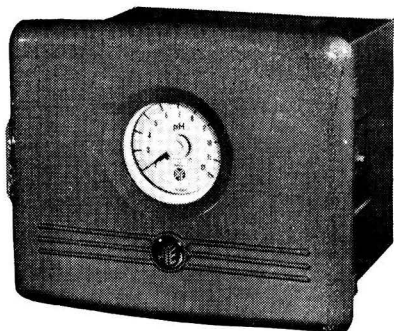

### INDUSTRIAL pH AMPLIFIER "H" CAT. No. 11530

The Pye Industrial pH Amplifier has been designed to operate under the widest range of factory conditions and provides a robust, reliable and accurate means of achieving higher productivity, better quality of products and considerable saving in labour and plant maintenance costs.

The instrument is essentially a voltage amplifier with a high internal gain and a large amount of negative feedback; there is exceptional linearity of response and the sensitivity is unaffected by mains variations or valve changes. The sensitivity is high (100 microamps/pH) and therefore external recorders, indicators, controllers and alarm systems can be operated from the same amplifier and may if necessary be mounted some distance away. Complete automatic temperature compensation is provided over the range 0-100°C. There is exceptional zero stability.

The pH Amplifier is supplied in a flush mounting, moisture and fume-proof case. A flameproof model (Cat. No. 11540) is also available.

The panel meter has an 8 inch scale length and is calibrated 2-12pH or to the range specified by the customer.

The pH Amplifier is designed to operate with Pye electrode assemblies, either the Immersion Type or the Continuous Flow Type. They are adaptable to virtually all types of processes and are robust, reliable and easy to maintain.

SCIENTIFIC  INSTRUMENTS

*Please write for our new leaflets.*

**W. G. PYE & CO. LTD.,**  
**GRANTA WORKS, NEWMARKET RD., CAMBRIDGE.**  
 Tel: Cambridge 54411. Grams: Pye, Cambridge

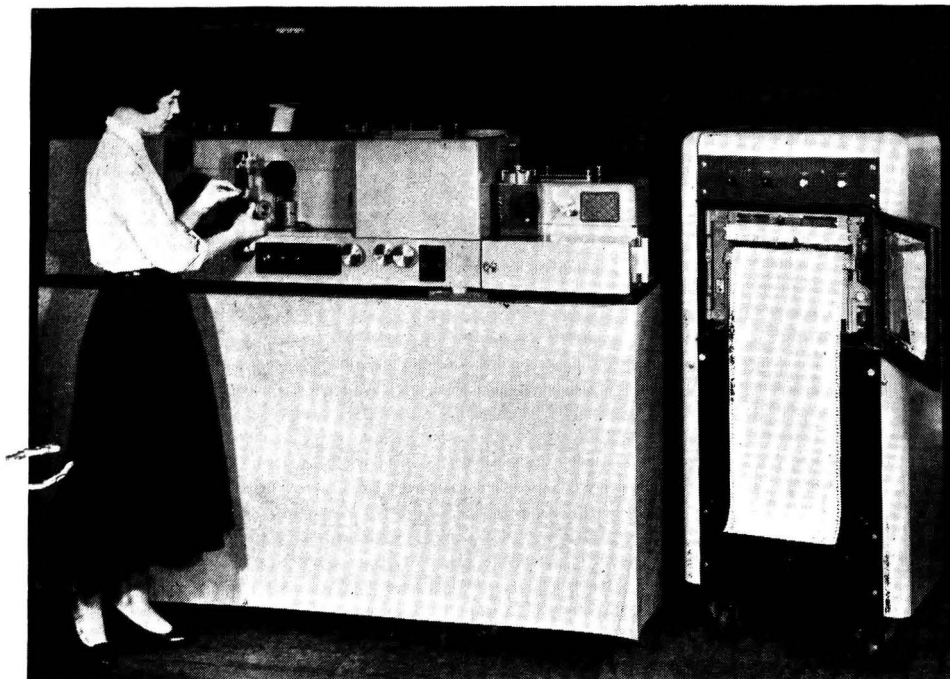

### *Why the H 800?*

Why the H 800? That is a question best answered perhaps by one of the many users of the instrument who find that it meets their most exacting requirements. But here are a few of the reasons for their choosing the H 800 infra-red recording spectrophotometer in the first place:

- High resolution—one wave number at 10 microns using a sodium chloride prism, 948.8  $\text{cm}^{-1}$  and 952  $\text{cm}^{-1}$  bands of ammonia easily resolved, even when scanning at one micron per minute.
- Wide spectral range—from the visible up to 40 microns.
- Low stray light—less than one per cent at 14 microns, using a sodium chloride prism.
- Reproducibility—less than  $\pm \frac{1}{2}$  per cent difference between two readings made on any one sample.
- Accuracy |better than  $\frac{1}{2}$  per cent of full-scale deflection, in transmission measurements.
- Versatility — double-beam microscope polarizer, integrator, grating mount, and other accessories available.

*For full details of the H 800, write for catalogue CH 310/f9*



98 ST PANCRAS WAY LONDON NW1

Telephone: Gulliver 5636



## “QUICKFIT” KJELDAHL APPARATUS

Write now for this Supplement No. 5. It is a constructive and informative booklet illustrating apparatus for determination of Nitrogen content. It details semi-micro and macro Kjeldahl apparatus which can further be utilised for distillation of some fatty acids and for general steam distillation.

TELEPHONE

Stone 481

QUICKFIT & QUARTZ LTD., Dept. O.U., “Quickfit” Works, Heart of STONE, STAFFS.

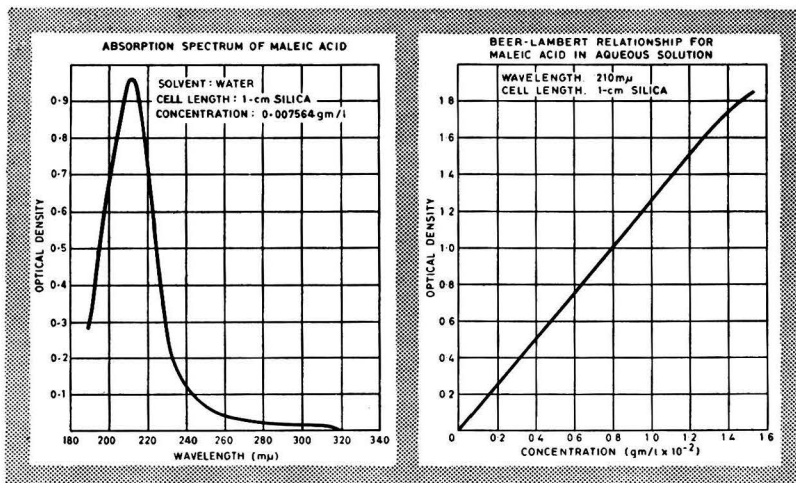

## High performance at low wavelengths

The absorption spectrum of maleic acid reproduced here emphasises the excellent performance of the SP.500 Spectrophotometer at low wavelengths. The second graph shows the Beer-Lambert relationship\* at 210mμ, and illustrates the virtual freedom from stray light at this wavelength.

With the new fused silica prism, the SP.500 Spectrophotometer reaches still further into the ultraviolet—down to 186mμ, the limit set by the absorption bands of atmospheric oxygen. The advantages of this are two-fold: a new region, hitherto accessible only to specially prepared instruments is made available for every user, and the performance of the instrument, over the whole of the important 200mμ—240mμ region, reaches a new high level. The standard test specification for the SP.500 now stipulates not more than 0.2% stray light at 200mμ—a clear indication of the instrument's quality.



**UNICAM**  
SP. 500 SPECTROPHOTOMETER

UNICAM INSTRUMENTS LIMITED · ARBURY WORKS · CAMBRIDGE

U185A

# VERSATILE



The Perkin-Elmer Vapour Fractometer separates gases and liquids with boiling points up to 400°C. Requiring only a very small sample, the Fractometer achieves quick and accurate analysis, and the separated components can conveniently be collected. We should like to supply full details.

**Vapour Fractometer  
(Model 154)**

Separates multi-component mixtures boiling up to 400°C  
 Highly-sensitive thermal conductivity detector (Thermistor type)  
 Choice of over 20 different columns for wide range of applications  
 Columns easily interchanged  
 Accessories include  
 Precision gas sampling system  
 Precision liquid introduction system  
 Columns for preparative scale work  
 Sample components easily collected under all conditions

**Perkin-Elmer**

**ANALYTICAL  
INSTRUMENTS**

160 Cheapside, London EC2 · Telephone MONarch 8177



# New 'Stabilec' Oven



**To satisfy the current need for a reliable, low-priced laboratory oven, B.T.L. offer a completely redesigned version of their famous 'Stabilec' oven.**

The oven chamber is corrosion resistant, with a choice of stainless steel or electro-tinned mild steel, and contains two removable shelves. The oven is heated by convection from easily replaceable elements, and temperature is indicated by a bent-stemmed thermometer in the door. Temperature control is by means of a B.T.L. bimetallic regulator. The control knob is marked 0-100 and a calibration table is supplied with each oven. The temperature range is 30°C. — 200°C. with reproducibility within  $\pm 1^\circ\text{C}$ .

Overall size: 24" x 17" x 17½"; internal chamber space: 14" x 12" x 12"; weight: 32 lbs.

C22/018 (Electro-tinned) £26 10s. 0d.

C22/019 (Stainless) £32 0s. 0d.



*complete laboratory service*

BAIRD & TATLOCK (LONDON) LTD · CHADWELL HEATH · ESSEX · ENGLAND  
Branches in London, Manchester and Glasgow. Agents throughout U.K. and all over the world

TAS/BT41

# Lab's Labour Lost

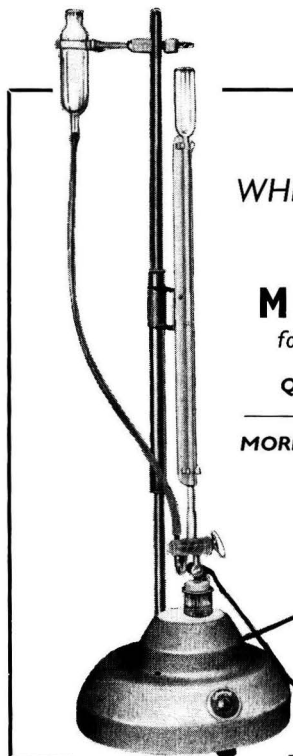

## WHEN YOU USE THE NEW **Gallenkamp** **POTENTIOMETRIC MICROTITRATION APPARATUS.**

*for quicker and more accurate determinations of chlorides*

### QUICKER

Each determination takes about 2 minutes—over 100 a day.

### MORE ACCURATE

Accurate to better than  $\pm 1\%$  of total quantity determined.



A complete description of the apparatus, which is due to Dr. I. D. P. Wootton, Ph.D., M.A., M.B., B.Chir., F.R.I.C. is given in "Micro-Analysis in Medical Biochemistry" 3rd ed. by E. J. King and I. D. P. Wootton. See also Laboratory Equipment Test Report No. 35, "Laboratory Practice" 8, 1, 1959, 11.

This new apparatus is simple to operate and specially designed for multiple routine determinations of chlorides in

- ★ Plasma      ★ Serum
- ★ Cerebro-spinal fluids
- ★ Urine

and determinations of salinity

- Semi-micro scale—only 0.2 ml sample required, 1% accuracy.
- Results direct in mE/i.
- Uses only two standard solutions—no indicators.
- Trouble-free magnetic stirring.
- Built-in galvanometer—complete freedom from sticking on slow approach to objective end point.
- Mains operated. Nothing to wear out.

ASK FOR PUBLICATION 601.

# Gallenkamp

## SUPPLY THE WORLD'S LABORATORIES

A. GALLENKAMP & CO. LTD., Sun Street, London, E.C.2  
Telephone: Bishopgate 0651    Telegrams: Gallenkamp, Stock, London

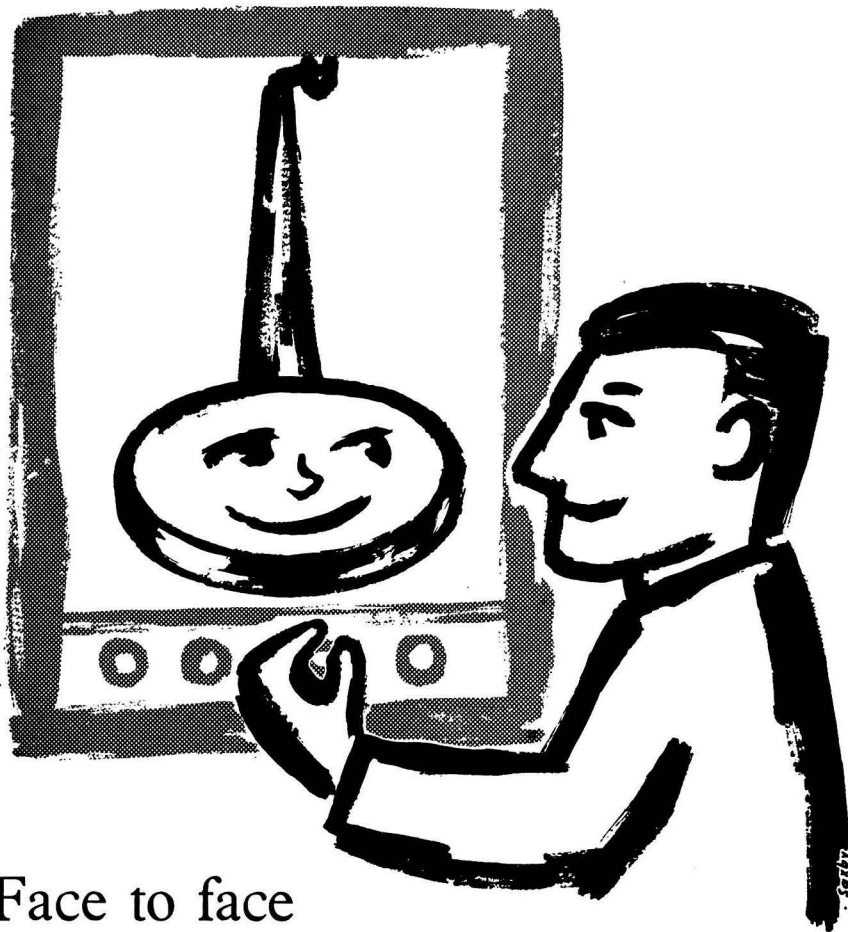

# Face to face

## with speed and accuracy

The **speed** of the Oertling One-pan balance comes from its excellent functional design plus, of course, the **Releas-o-Matic** two-speed automatic release which permits rapid weighing without damage.

The **accuracy** comes from the excellent technical design plus, again, **Releas-o-Matic** which protects the knife-edges throughout years of constant use.

**Speed, accuracy, Releas-o-Matic** — three excellent reasons for choosing an Oertling. And the fourth is the nation-wide Oertling "after-sales" maintenance service. Write for details to: L. Oertling Ltd., St. Mary Cray, Kent, or ring Orpington 25771.

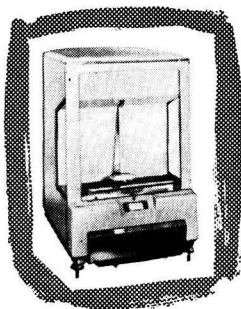

### better weighing

# STANTON'S

## NEW 1959 CATALOGUE

is your complete guide to  
precision balances

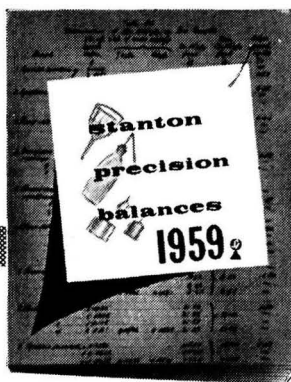

*Here's a selection you can't afford to miss*

### *New Features* — Set of weights included

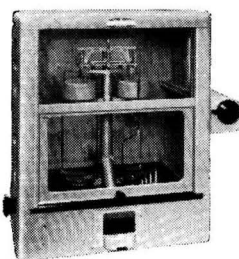

#### STANTON A.49

Already one of the most popular balances in our range. A set of five weights from 10-100 g. is now built into the case on a small turntable adjacent to the pan, for greater convenience and quicker weighing.

Capacity 200 g Sensitivity 0.1 mg.

### *New Feature* — Twin Bankweight Loading

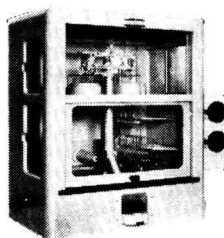

#### STANTON B.20

A worthy successor to Britain's first full Weight-loading Balance, this model now incorporates a new graticule and twin bank weightloading, for greater convenience and quicker weighing.

Capacity 200g Sensitivity 0.1 mg.

### *New Feature* — Vernier Scale — Partial Release

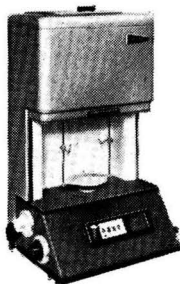

#### STANTON ULTRAMATICS

Four models now available, all incorporating facilities for tare weighing and partial release. New numbered Vernier Scales on Models U.M.3 and U.M.10, for greater convenience and quicker weighing.

Capacity 200 g Sensitivities 0.1 mg.—1 mg.

### *And still the best value obtainable—*

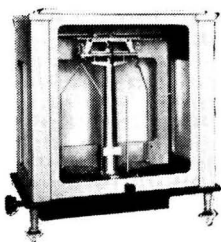

#### STANTON C.26

A firm favourite in schools and University Laboratories where accuracy, dependability and robustness are the key requirements.

Capacity 200 g Sensitivity 0.1 mg.

*Our new catalogue is more informative than our press advertisement. A DEMONSTRATION will be more convincing than either. A postcard will bring a technical representative to your laboratory.*



*Guaranteed*  
**STANTON PRECISION BALANCES**

STANTON INSTRUMENTS LTD., 119 Oxford Street, London, W.1. Telephone Gerrard 7533/4

# Scientific groundwork in Pyrex

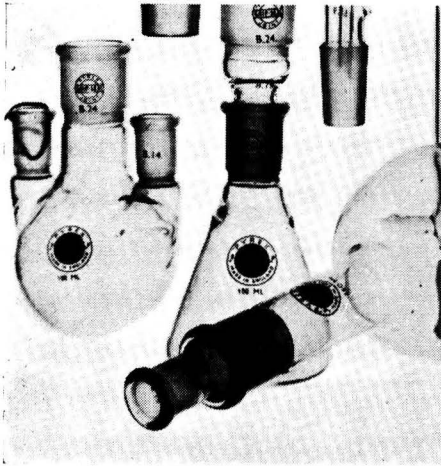

—or, to be precise, scientific ground *glass* work. A craftsman's job, this. Assemblies of scientific apparatus, like chains, are at the mercy of their weakest link: the joint that won't join, maybe, or the stopper that won't stop. PYREX have been making apparatus for years. They know you can't get interchangeability, quick assembly, quick dismantling and long life without the precision of real craftsmanship. PYREX are always improving their production methods to attain even higher standards of quality. This is one good reason (among many) why everyone who is looking for quality glassware looks for PYREX

## 'GRIP-SEAL' interchangeable ground glass joints

precision-ground to close-limit tolerances meeting BSI recommendations  
heavy wall, robust moulded section, extra tough clamping area  
anti-chip, fire-polished ends  
wide adaptability and the chemical-mechanical-thermal stability of all PYREX glass!

● Ask for a catalogue from

INDUSTRIAL SALES DIVISION JAMES A JOBLING & CO LTD Wear Glass Works Sunderland

# PYREX

Regd. Trade Mark

BRAND



## Laboratory and scientific glass



This one  
address  
is the key

S I M A

**INSTRUMENT CENTRE**

20 QUEEN ANNE STREET, LONDON, W.1

Telephone: IMPerial 6000

(Press enquiries: LANgham 4251)

Here the whole world can find the finest scientific instruments, key information and prompt advice.

- ★ Electronic and nuclear instruments
- ★ Navigational and survey equipment
- ★ Optical and ophthalmic instruments
- ★ Laboratory, medical and X-ray apparatus
- ★ Instruments for process control and automation
- ★ Kinematograph and allied instruments
- ★ All industrial instrumentation

THE SCIENTIFIC INSTRUMENT MANUFACTURERS ASSOCIATION OF GREAT BRITAIN

Space presented by TOWNSON & MERCER LIMITED, Croydon, England. Specialists in precision constant temperature apparatus.

# THE ANALYST

## PROCEEDINGS OF THE SOCIETY FOR ANALYTICAL CHEMISTRY

### SPECIAL MEETING

A SPECIAL Meeting of the Society was held at 7 p.m. on Wednesday, May 20th, 1959, in the meeting room of the Chemical Society, Burlington House, London, W.1. The Chair was taken by the President, Mr. R. C. Chirnside, F.R.I.C.

The subject of the meeting was "The Determination of Vitamin E; A Collaborative Study of Quantitative Paper Chromatography and the Development of a Recommended Method of Analysis." The speakers, all members of the Vitamin-E Panel of the Analytical Methods Committee, were A. L. Bacharach, M.A., F.R.I.C.; J. Green, B.Sc., Ph.D., F.R.I.C.; P. W. Russell Eggitt, B.Sc., Ph.D., F.R.I.C.; R. J. Ward, B.Sc., Ph.D., F.R.I.C.

### DEATHS

WE record with regret the deaths of—

Andrew Carey

Henry Dryerre

Harold Harman

Frederick Leigh Okell.

### NORTH OF ENGLAND SECTION

AN Ordinary Meeting of the Section was held at 2.15 p.m. on Saturday, April 11th, 1959, at the City Laboratories, Mount Pleasant, Liverpool. The Chair was taken by the Chairman of the Section, Dr. J. R. Edisbury.

The following paper was presented and discussed: "The Training of Analytical Chemists," by G. F. Longman, B.Sc., F.R.I.C., and J. W. Lucas, B.Sc., F.R.I.C.

### WESTERN SECTION

A JOINT Meeting of the Western Section with the Mid-Southern Counties Section of the Royal Institute of Chemistry was held at 7.45 p.m. on Wednesday, April 8th, 1959, at the Cathedral Hotel, Salisbury. The Chair was taken by Mr. P. J. C. Haywood, B.Sc., F.R.I.C.

The following paper was presented and discussed: "Advantages and Disadvantages of Visual Colorimetry," by G. J. Chamberlin.

The meeting was preceded at 5.30 p.m. by a visit to the works of The Tintometer Ltd.

### MIDLANDS SECTION

AN Ordinary Meeting of the Section was held at 6.30 p.m. on Thursday, April 9th, 1959, in the Mason Theatre, The University, Edmund Street, Birmingham 3. The Chair was taken by the Chairman of the Section, Dr. S. H. Jenkins, F.R.I.C., F.Inst.S.P.

The following paper was presented and discussed: "Analytical Chemistry in Glass Manufacture," by J. Davies.

AN Ordinary Meeting of the Section was held at 6.30 p.m. on Thursday, April 30th, 1959, at Boots Pure Drug Co. Ltd., Beeston, Nottingham. The Chair was taken by the Chairman of the Section, Dr. S. H. Jenkins, F.R.I.C., F.Inst.S.P.

The following paper was presented and discussed: "Quality Control in a Pharmaceutical Organisation," by D. C. Garratt, Ph.D., D.Sc., F.R.I.C.

The meeting was preceded by a conducted tour of some of the laboratories of Boots Pure Drug Co. Ltd. and a short film show.

#### BIOLOGICAL METHODS GROUP

A DISCUSSION Meeting of the Group was held at 6.30 p.m. on Thursday, April 16th, 1959, in "The Feathers," Tudor Street, London, E.C.4. The Chair was taken by the Vice-Chairman of the Group, Mr. J. S. Simpson, F.I.M.L.T.

A discussion on "Problems of Recording and Communicating Technical Information in a Commercial Research Organisation" was opened by Pamela D. Waterhouse, B.Sc.

#### SUMMARY OF A PAPER PRESENTED AT A MEETING OF THE SCOTTISH SECTION

THE following is a summary of the paper presented by E. L. P. Mercy, Ph.D., D.I.C., at the Ordinary Meeting of the Scottish Section on Wednesday, March 18th, 1959, in Glasgow. A first report appeared in *The Analyst*, 1959, **84**, 258.

#### A REVIEW OF THE RAPID METHODS OF SILICATE ANALYSIS

DR. EDWARD L. P. MERCY reviewed and criticised the systems of analysis of silicate rocks and similar materials by spectrophotometric, volumetric and flame-photometric techniques. One such system had been investigated by Mercy (*Geochim. Cosmochim. Acta*, 1956, **9**, 161), and it was shown that the precision and accuracy obtainable under routine conditions were comparable with the ordinary standards expected from inorganic chemical analysis. In the opinion of the author, all published methods had defects, especially in the determination of aluminium, calcium, magnesium and sodium. Current research was directed towards eliminating such defects and increasing the accuracy of the methods. Recent developments, such as the use of hexamine in the separation of the  $R_2O_3$  group and the direct titration of aluminium with EDTA in the presence of iron, titanium, calcium and magnesium, were discussed.

## Report of the Analytical Methods Committee 1958

THIS fourth Report of the Analytical Methods Committee of the Society for Analytical Chemistry gives an account of the progress of work during the twelve months ending February 28th, 1959.

#### GENERAL REVIEW

During the year the Committee was sorry to lose through resignation both Mr. R. C. Chirnside and Dr. J. Haslam after many years' service as members of the Committee. Their help and guidance was much appreciated and this opportunity is taken to express to them the thanks of the Committee.

They are succeeded by Mr. W. T. Elwell and Mr. H. N. Wilson, who joined the Committee in June.

#### PROGRESS OF WORK—

The year has been one of continued progress in the activities of the Committee; there has been an increase in the number of sub-committees and panels and a marked increase in the number of committee meetings.

*Work completed*—The notable event during the summer was the publication of "Recommended Methods for the Analysis of Trade Effluents," prepared by the Joint Committee



of the Society and the Association of British Chemical Manufacturers. Although all the methods (between 50 and 60) contained in the book had been published individually in *The Analyst* during the preceding two years, the book itself has had an immediate success. The Joint Committee completed the work in a comparatively short time (three and a half years altogether), although a considerable amount of practical investigation was entailed.

The Vitamin-E Panel of the Analytical Methods Committee has now completed its work and its method for "The Determination of Tocopherols in Oils, Foods, and Feeding Stuffs," to be published early in the summer, is the outcome of five years' collaborative research by members of the Panel. An account of the problems encountered and the original work carried out to resolve them is to be the subject of a special meeting of the Society in May.

The beginning of the year saw the completion of the research work at Harwell by the Society's Research Scholar, Mr. T. T. Gorsuch, on the use of radiochemical techniques to investigate the recovery of trace elements from organic materials. This work was sponsored by the Analytical Methods Trust Fund in 1956, and Mr. Gorsuch worked in close collaboration with the Metallic Impurities in Organic Matter Sub-Committee throughout his investigations. His report is to be published in the March issue of *The Analyst*, but a preview describing his work was given to a large audience at the Royal Institution last October.

Meanwhile, work continues in the existing Sub-Committees of the Analytical Methods Committee and the Panels of the Joint Committee with the Pharmaceutical Society, and it is satisfactory to report that some of these have already completed part of their original programmes.

The Metallic Impurities in Organic Matter Sub-Committee extensively revised the method for lead (originally published in 1954) and will publish its report in the March issue of *The Analyst*: it has also prepared a report on the uses and handling of perchloric acid, to be published in the April issue.

A panel of the Joint Committee with the Pharmaceutical Society, which is investigating methods of assay of crude drugs, has prepared a short report for publication in the April issue of the *Journal of Pharmacy and Pharmacology* on the stability of solutions of rescinnamine and of trimethoxycinnamic acid during exposure to daylight. This work arose out of the panel's investigation into spectrophotometric methods for the assay of rauwolfia, in which it was found that exposure to daylight markedly affected the ultra-violet absorption characteristics of the solutions but did not alter their pharmacological activities. Two other panels of this Joint Committee have completed the first parts of their programmes, and their reports are being prepared for publication. One of these, on methods for determining the capsaicin content of Capsicum, B.P.C., and some of its products, has already been approved, and publication is expected later in the year: the other report, on a method for determining the rotenone content of ground *Lonchocarpus* root, is in preparation.

Other sub-committees and panels not mentioned above are continuing investigations of methods for—

Meat products;

Direct micro-determination of oxygen in organic matter (Unterzaucher method);

Trace elements in fertilisers and feeding stuffs;

Essential oils;

Anthraquinone drugs; and

*Digitalis* (chemical method).

*New projects*—The value of collaborative investigations by technical committees is being increasingly recognised, as evidenced by requests during the year from two organisations for the preparation of recommended methods of analysis.

In the first instance, the Scientific Sub-Committee of the Ministry of Agriculture, Fisheries and Food approached the Analytical Methods Committee for information about standard methods for the determination of those additives commonly used to supplement animal and poultry feeding stuffs. Because of the wide interest in the problem, the Analytical Methods Committee agreed to undertake the work. A steering Sub-Committee was set up at the end of 1958, and the task of selecting or preparing suitable methods has been delegated to four working panels, whose members are specialists in the analysis of the particular types of additives concerned, namely, antibiotics, prophylactics, trace elements and vitamins. All the panels have drawn up their programmes of work and have begun collaborative check tests of suggested methods.

แผนกห้องสมุด กรมวิทยาศาสตร์

กระทรวงอุตสาหกรรม

In the second instance, a new sub-committee has been appointed to investigate methods for determining semi-micro amounts of chlorine in organic compounds, particularly pesticide formulations. This work, which has already reached an advanced stage, was undertaken at the request of the Association of British Manufacturers of Agricultural Chemicals.

Another sub-committee that started work during the year is that on methods for the determination of pesticides in foodstuffs. A sub-committee for this purpose was first appointed in 1954 and published in 1957 its report on "The Determination of Small Amounts of Organic Chlorine in Solvent Extracts of Vegetable Material." With the planning of a larger programme of work, having a wider scope than before, the sub-committee has been reconstituted as a steering committee with power to delegate individual projects to working panels.

One of the first tasks of this sub-committee has been the planning of an investigation into possible qualitative methods for the biological determination of the presence or absence of toxic residues in foods. To this end a short preliminary survey is to be made of any information that may be available in British and Continental laboratories, and a grant has recently been awarded by the Trustees to Mr. P. H. Needham of Rothamsted Experimental Station to carry out this work. The practicability of instituting a longer-term research project into the development of a suitable method will be assessed when the results of the survey are known.

Last year it was reported that agreement had been reached by the Analytical Methods Committee with the Scientific Sub-Committee on Poisonous Substances used in Agriculture and Food Storage of the Ministry of Agriculture, Fisheries and Food and with the Association of British Manufacturers of Agricultural Chemicals for the collaborative testing of proposed methods of analysis of pesticides residues in foodstuffs—the request for such tests to be made by any of the three organisations when a method is deemed to be at a suitable stage of development. Two methods are at present under test—one for DDT and one for BHC—each by a separate working Panel composed of members nominated by the three organisations, the responsibility for the Analytical Methods Committee's share in the scheme being assumed by the Pesticides Residues Sub-Committee.

Fuller details of the personnel, terms of reference and progress of work of all sub-committees, joint committees and panels will be found on p. 333.

*Publication of Standard Methods*—When the Analytical Methods Committee was reorganised in 1955, it was intended that the functions of the secretariat should be two-fold: (a) to service and co-ordinate the work of all technical sub-committees and joint committees with other organisations, and (b) to undertake the editorial work connected with the projected expansion of the "Bibliography of Standard Methods of Analysis" (published in 1951) into a complete collection of methods.

However, the demand made for the preparation of new methods by technical committees does not leave any time for the present secretariat to devote to the collection and editing of existing standard methods. It has, therefore, recently been decided that this editorial work is of sufficient importance to merit the appointment of a Publications Secretary under the direction of a special Publications Sub-Committee.

#### RESEARCH PROJECTS—

As mentioned earlier in this Report, the first full-scale research project sponsored by the Committee has been successfully completed, namely that by Mr. Gorsuch, at Harwell, employing radiochemical techniques, and a second project has now been started to explore the possibilities of devising a rapid biological "sorting" test for toxic pesticide residues in food.

A third project sponsored by the Committee has been a short-term investigation under the direction of Dr. H. M. N. H. Irving at Oxford to devise a method for determining traces of silver in the presence of organic matter. This investigation, which arose out of the work of the Joint Committee with the Association of British Chemical Manufacturers during the preparation of methods for the analysis of trade effluents, has been completed, and a report is in preparation.

#### ANALYTICAL METHODS TRUST FUND—

The first three years of the Committee's existence as a financially independent unit of the Society was completed last year, and the Trustees made a renewed appeal to the original

subscribers to the Trust Fund for a continuation of their subscriptions. The result was that 45 industrial organisations gave donations for 1958, the total received being £5394. Of these, 18 gave promises of annual sums for periods varying from three to seven years, 10 were already under contract by Deeds of Covenant for a period of seven years and 17 gave single donations.

#### INCOME AND EXPENDITURE—

The audited statement of accounts (see Appendix I) for the financial year ending October 31st, 1958, shows an expenditure of £4086 and a total income of £6026. The expenditure is a decrease of £688 on that for 1957, which included capital expenditure on office equipment as a result of the move to permanent offices as well as the second year's scholarship grant.

It is estimated that the expenditure for 1959 will be considerably higher owing to increase in the work of the Committee, necessitating the appointment of additional staff, including a Publications Secretary (see p. 332).

### REPORTS OF SUB-COMMITTEES OF THE ANALYTICAL METHODS COMMITTEE

#### ADDITIVES IN ANIMAL FEEDING STUFFS SUB-COMMITTEE

##### CONSTITUTION—

D. C. Garratt, Ph.D., D.Sc., F.R.I.C.

(Chairman)

A. J. Amos, B.Sc., Ph.D., F.R.I.C.

J. H. Hamence, M.Sc., Ph.D., F.R.I.C.

R. F. Phipers, B.Sc., Ph.D.

S. A. Price, B.Sc., F.R.I.C.

C. J. Regan, B.Sc., F.R.I.C.

W. L. Sheppard, A.R.I.C.

R. E. Stuckey, Ph.D., D.Sc., F.P.S., F.R.I.C.

F. R. Williams

Miss C. H. Tinker (Secretary)

*Boots Pure Drug Co. Ltd.*

*Analytical and Consulting Chemist*

*Public Analyst, Official Agricultural Analyst and*

*Consulting Chemist*

*The Cooper Technical Bureau*

*Vitamins Ltd.*

*Formerly Chemist-in-Chief, London County Council*

*Unilever Ltd.*

*British Drug Houses Ltd.*

*Ministry of Agriculture, Fisheries and Food*

TERMS OF REFERENCE—"To investigate and prepare methods for determining the amounts of additives (nutrients, stimulants and prophylactics) in animal and poultry feeding stuffs.

##### PROGRAMME OF WORK—

As mentioned earlier in this Report (p. 331), this Sub-Committee was appointed in October, 1958, as a result of a request from the Scientific Sub-Committee of the Ministry of Agriculture, Fisheries and Food for information on the existence of suitable methods for determining the amounts in animal and poultry feeding stuffs of those substances normally used to supplement the feed.

The Sub-Committee itself acts in a steering capacity, and the work of investigating the suitability of existing methods, or of devising new methods if necessary, has been delegated to various working panels. Four of these panels have so far been appointed and they are already engaged in a programme of collaborative tests of proposed methods for antibiotics, prophylactics and vitamins (sub-divided into two panels for the fat-soluble and the water-soluble types, respectively). These check tests are necessary to determine the validity of the methods when applied to such complex materials as feeding stuffs, since the additives are usually present at very low concentrations and the presence of other additives as well as the normal constituents of the feed may interfere with the determinations.

Methods for the determination of mineral additives are already under investigation by another Sub-Committee, namely that on Trace Elements in Fertilisers and Feeding Stuff (see p. 338).

The constitutions and programmes of work of the four panels are given below.

#### ANTIBIOTICS PANEL

##### CONSTITUTION—

S. A. Price, B.Sc., F.R.I.C.

(Chairman)

A. J. Cavell, M.Sc., A.R.C.S., D.I.C., F.R.I.C.

*Vitamins Ltd.*

*Ministry of Agriculture, Fisheries and Food,  
National Agricultural Advisory Service*

O. Hughes  
 J. S. Simpson, F.I.M.L.T.  
 Miss J. Stephens, B.Sc.  
 G. Sykes, M.Sc., F.R.I.C.  
 J. H. Taylor, Ph.D., M.R.C.V.S.  
 Miss A. M. Parry (*Secretary*)

*Pfizer Ltd.*  
*Glaxo Laboratories Ltd.*  
*Distillers Co. Ltd.*  
*Boots Pure Drug Co. Ltd.*  
*Cyanamid of Great Britain Ltd.*

#### PROGRAMME OF WORK—

Chemical and microbiological methods (depending on the level in the feed) for the following antibiotics, permitted by law in the United Kingdom, are being examined: penicillin; aureomycin; oxytetracycline ("Terramycin").

#### PROPHYLACTICS PANEL

##### CONSTITUTION—

R. F. Phipers, B.Sc., Ph.D.  
 (*Chairman*)  
 C. W. Ballard, B.Sc., F.P.S., F.R.I.C.  
 N. C. Brown, M.A., B.Sc., A.R.I.C.  
 H. G. Dickinson, B.Sc., Ph.D.  
 A. W. Hartley, F.R.I.C.  
 A. Holbrook, F.R.I.C.

*The Cooper Technical Bureau*

*May & Baker Ltd.*  
*The Cooper Technical Bureau*  
*Ward, Blenkinsop & Co. Ltd.*  
*Spillers Ltd.*  
*Imperial Chemical Industries Ltd. (Pharmaceutical Division)*  
*Smith Kline & French Laboratories Ltd.*

S. G. E. Stevens, B.Sc., F.R.I.C.  
 Miss A. M. Parry (*Secretary*)

#### PROGRAMME OF WORK—

Chemical methods for the following prophylactics (coccidiostats and anti-blackhead drugs) are being examined—

Sulphaquinolaxaline	Aminonitrothiazole
Sulphadimidine (sulphamethazine)	Acinitrazole
Sulphaguanidine	Furazolidine
Nitrofurazone	
Nitrophenide	
Nicarbazin (pyrimethamine)	

#### VITAMINS (FAT-SOLUBLE) PANEL

##### CONSTITUTION—

W. L. Sheppard, A.R.I.C.  
 (*Chairman*)  
 C. R. Loudon, B.Sc., F.R.I.C.  
 R. A. Rabnott  
 S. A. Reed, B.Sc., A.R.I.C.  
 K. L. Smith, M.P.S.  
 G. Walley, B.Sc., F.R.I.C.  
 J. Williams, B.Sc., Ph.D., F.R.I.C.  
 D. R. Wraige, B.Sc., A.R.I.C.  
 Miss C. H. Tinker (*Secretary*)

*Unilever Ltd.*

*R. Silcock & Sons Ltd.*  
*Analytical and Consulting Chemist*  
*The British Cod Liver Oil Co.*  
*Boots Pure Drug Co. Ltd.*  
*Unilever Ltd.*  
*Spillers Ltd.*  
*J. & H. Robinson Ltd.*

#### PROGRAMME OF WORK—

Chemical methods for vitamin A and for  $\beta$ -carotene are being examined.

#### VITAMINS (WATER-SOLUBLE) PANEL

##### CONSTITUTION—

A. J. Amos, B.Sc., Ph.D., A.R.I.C.  
 (*Chairman*)  
 B. M. Gibbs, B.Sc., A.R.I.C.  
 S. A. Price, B.Sc., F.R.I.C.  
 H. Pritchard, M.Sc., F.R.I.C.  
 F. Clermont Scott, B.Sc., F.R.I.C.  
 J. S. Simpson, F.I.M.L.T.  
 G. Sykes, M.Sc., F.R.I.C.  
 J. Williams, B.Sc., Ph.D., F.R.I.C.  
 Miss C. H. Tinker (*Secretary*)

*Analytical and Consulting Chemist*

*Unilever Ltd.*  
*Vitamins Ltd.*  
*Analytical and Consulting Chemist*  
*Vitamins Ltd.*  
*Glaxo Laboratories Ltd.*  
*Boots Pure Drug Co. Ltd.*  
*Spillers Ltd.*

## PROGRAMME OF WORK—

Microbiological methods for the following vitamins are being examined: riboflavin; vitamins B<sub>12</sub> (cyanocobalamins and derivatives); nicotinic acid (and derivatives); pantothenic acid; vitamin B<sub>6</sub> (pyridoxine); and choline.

Vitamin E (particularly  $\alpha$ -tocopherol), which is also added to feeds, has already been investigated by a panel of the Analytical Methods Committee, and a comprehensive report on its determination, involving the use of paper chromatography as a quantitative chemical procedure, is to be published shortly (see also p. 338).

## CHLORINE IN ORGANIC COMPOUNDS SUB-COMMITTEE

## CONSTITUTION—

R. Belcher, Ph.D., D.Sc., F.Inst.F., F.R.I.C.

(Chairman)

J. H. Dunn, B.Sc., A.R.I.C.

K. Gardner, B.Sc., F.R.I.C.

R. Goulden, A.R.I.C.

G. Ingram, A.R.I.C.

Miss A. M. G. Macdonald, M.Sc., Ph.D., A.R.I.C.

Miss C. H. Tinker (Secretary)

*University of Birmingham (Department of Chemistry)*

*Imperial Chemical Industries Ltd. (Central Agricultural Control)*

*Fisons Pest Control Ltd.*

*"Shell" Research Ltd.*

*Courtaulds Ltd.*

*University of Birmingham (Department of Chemistry)*

TERMS OF REFERENCE—"To prepare methods for the determination of organically-bound chlorine, having special reference to commercial preparations such as pesticides."

## PROGRESS OF WORK—

As mentioned earlier in this Report (see p. 332), this Sub-Committee was appointed in July, 1958, as a result of a request by the Association of British Manufacturers of Agricultural Chemicals for a method for organically-bound chlorine. Although the immediate requirement for such a method is in connection with the analysis of pesticides, the selection of a general method having wider applications has been considered desirable. To this end a number of materials having chlorine contents ranging from 1 to 65 per cent. are being tested collaboratively on the semi-micro scale by an oxygen combustion method.

## ESSENTIAL OILS SUB-COMMITTEE

## CONSTITUTION—

G. W. Ferguson, B.Sc., Ph.D., F.R.I.C.

(Chairman)

A. J. M. Bailey, B.Sc., F.P.S., F.R.I.C.

D. Holness, B.A.

H. T. Islip, B.Sc., F.R.I.C.

P. McGregor, B.Sc., A.H.-W.C., F.R.I.C.

T. L. Parkinson, B.Sc., Ph.D., F.R.I.C.

J. H. Seager, M.Sc., F.R.I.C.

G. E. Smith, B.Sc., F.R.I.C.

S. G. E. Stevens, B.Sc., F.R.I.C.

B. D. Sully, B.Sc., Ph.D., A.R.C.S., F.R.I.C.

Miss C. H. Tinker (Secretary)

*Analytical and Consulting Chemist*

*W. J. Bush & Co. Ltd.*

*Unilever Ltd.*

*Tropical Products Institute*

*Department of the Government Chemist*

*Beecham Food Products Research Department*

*Yardley & Co. Ltd.*

*Stafford Allen & Sons Ltd.*

*Smith Kline & French Laboratories Ltd.*

*A. Boake, Roberts & Co. Ltd.*

## PROGRESS OF WORK—

The Sub-Committee is engaged in the re-examination of the older chemical methods for the analysis of essential oils in the light of modern techniques, particularly gas-liquid chromatography and infra-red spectroscopy. By means of the former, the chemical reactions during analysis are being studied, the results obtained with the oils being compared with those from synthetic mixtures of the pure constituents; infra-red spectroscopy is used to check the purity of the standards. This type of investigation is being applied to the study of the Fiore and Glichitch methods for the determination of linalol, and also to the hot formylation method for the determination of citronellol in oils.

Alternative methods are being sought for the determination of phenols, since the present alkali absorption method is not specific. The efficiency of various drying agents for essential oils is being investigated. The Sub-Committee is also looking at methods for the determination of the non-volatile residue.

Close liaison is being maintained with the corresponding technical committee of the British Standards Institution, particularly in connection with the investigation of methods at present under discussion by the relevant committee of the International Organisation for Standardisation, of which the B.S.I. is the United Kingdom member.

#### MEAT PRODUCTS SUB-COMMITTEE

##### CONSTITUTION—

S. M. Herschdoerfer, Ph.D., F.R.I.C.

(Chairman)

S. Back, B.Sc., F.R.I.C.

Miss E. M. Chatt, B.Sc., F.R.I.C.

P. O. Dennis, B.Sc., F.R.I.C.

C. D. Essex, A.M.Inst.B.E., F.R.I.C.

J. R. Fraser, B.Sc., A.C.G.F.C., F.R.I.C.

R. A. Lawrie, B.Sc., Ph.D., A.R.I.C.

H. Amphlett Williams, Ph.D., A.C.G.F.C.  
F.R.I.C.

Miss C. H. Tinker (Secretary)

*T. Wall & Sons Ltd.*

*Crosse & Blackwell Ltd.*

*British Food Manufacturing Industries Research Association*

*Oxo Ltd.*

*Oxo Ltd.*

*Department of the Government Chemist*

*D.S.I.R., Low Temperature Research Station*

*Public Analyst*

TERMS OF REFERENCE—“(a) The determination of the meat content of products containing meat; (b) the determination of the constituents of meat and meat products.

NOTE—The term ‘meat products’ to include hydrolysed protein and, if found necessary, fish pastes.”

##### PROGRESS OF WORK—

The Sub-Committee has continued its collection of data on the nitrogen contents of various cuts of the different types of meat used in the manufacture of meat products, with a view to re-assessing the present values for nitrogen factors. This re-assessment has been considered necessary because it has long been thought that the factors recommended by Stubbs and More (based on the evidence to hand at that time) are no longer realistic. In an endeavour to collect as many data as possible, an appeal for information has been made to a number of European meat research organisations as well as to a number of manufacturers in Britain.

The Sub-Committee now considers that it has sufficient data for pork and is endeavouring to obtain more information on beef; it is hoped to be able to publish an interim report on the findings before long. Figures for turkey and chicken meats are to be considered next.

#### METALLIC IMPURITIES IN ORGANIC MATTER SUB-COMMITTEE

##### CONSTITUTION—

W. C. Johnson, M.B.E., F.R.I.C.

(Chairman)

L. Brealey, B.Sc.

Miss E. M. Chatt, B.Sc., F.R.I.C.††

J. C. Gage, B.Sc., Ph.D., F.R.I.C.

T. T. Gorsuch, B.Sc., A.R.I.C.†

C. L. Hinton, F.R.I.C.\*\*

E. I. Johnson, M.Sc., F.R.I.C.

I. MacIntyre, M.B., Ch.B.\*

T. McLachlan, D.C.M., A.C.G.F.C., M.I.Biol.,  
F.R.I.C.

R. F. Milton, B.Sc., Ph.D., M.I.Biol., F.R.I.C.

G. E. Willis, B.Sc., Ph.D., A.R.I.C.

Miss A. M. Parry (Secretary)

*Hopkin & Williams Ltd.*

*Boots Pure Drug Co. Ltd.*

*British Food Manufacturing Industries Research Association*

*Imperial Chemical Industries Ltd. (Industrial Hygiene Laboratories)*

*U.K. Atomic Energy Authority (The Radiochemical Centre)*

*British Food Manufacturing Industries Research Association*

*Department of the Government Chemist*

*University of London (Post-Graduate Medical School)*

*Public Analyst*

*Analytical and Consulting Biochemist*

*Imperial Chemical Industries Ltd. (Dyestuffs Division)*

\* Resigned—October, 1958.

\*\* Resigned—December, 1958.

† Elected—October, 1958.

†† Elected—January, 1959.

TERMS OF REFERENCE—“To investigate the determination of small quantities of metals in organic matter.”

## PROGRESS OF WORK—

Owing to pressure of work, Mr. T. McLachlan, Chairman of the Sub-Committee since its re-organisation in 1955, resigned from the Chair in July, and Mr. W. C. Johnson was appointed in his place; Mr. McLachlan will continue to serve as a member of the Sub-Committee.

*Method for lead*—The Report on the determination of lead has been completed and will be published in the March issue of *The Analyst*.

*Method for arsenic*—Final tests are being carried out by the molybdenum-blue method for arsenic and publication of the Report is expected during the coming year.

*Destruction of organic matter*—Work is proceeding on the collection of methods for the destruction of organic matter, both by wet and by dry combustion. This will be published as a separate document to which reference will be made in subsequent reports on the determination of trace metals.

Preliminary studies are now being made of methods for the determination of copper and mercury.

## DIRECT MICRO-DETERMINATION OF OXYGEN IN ORGANIC MATTER SUB-COMMITTEE

## CONSTITUTION—

D. W. Wilson, M.Sc., F.R.I.C.

(Chairman)

G. C. Ackroyd, B.Sc., A.R.I.C.

P. R. W. Baker, B.Sc., A.R.I.C.

Miss B. B. Bauminger, Ph.D., A.I.R.I., F.R.I.C.

W. T. Chambers, B.Sc., Ph.D., A.R.I.C.

A. F. Colson, B.Sc., Ph.D., F.R.I.C.

Miss M. Corner, B.Sc., F.R.I.C.

Miss J. Cuckney

F. Ellington, B.Sc., A.R.C.S., F.R.I.C.

G. Ingram, A.R.I.C.

F. J. McMurray

M. P. Mendoza, B.Sc., A.R.C.S.

F. H. Oliver

H. J. Warlow

C. Whalley, B.Sc., F.R.I.C.

Miss C. H. Tinker (Secretary)

*Sir John Cass College (Department of Chemistry)*

*D.S.I.R., Fuel Research Station*

*Wellcome Research Laboratories*

*Dunlop Research Centre*

*British Rubber Producers' Research Association*

*Imperial Chemical Industries Ltd. (Alkali Division)*

*D.S.I.R., National Chemical Laboratory*

*Imperial College of Science and Technology*

*(Department of Chemistry)*

*National Coal Board, Central Research Establishment*

*Courtaulds Ltd.*

*Wellcome Chemical Works*

*British Coal Utilisation Research Association*

*Parke, Davis & Co. Ltd.*

*D.S.I.R., Fuel Research Station*

*Laporte Chemicals Ltd.*

TERMS OF REFERENCE—"To investigate the Unterzaucher method, and its modifications, for the micro-determination of oxygen."

## PROGRESS OF WORK—

The Sub-Committee is continuing its investigation of the Unterzaucher method in an attempt to unify the procedure, since many small modifications to the original technique have been adopted from time to time by the various laboratories. Two series of collaborative tests have been carried out and, as a result, a third series is being planned to investigate the fundamental mechanism of the method.

## PESTICIDES RESIDUES IN FOODSTUFFS SUB-COMMITTEE

## CONSTITUTION—

R. A. E. Galley, B.Sc., Ph.D., A.R.C.S., D.I.C.,  
F.R.I.C. (Chairman)

G. L. Baldit, B.Sc., A.R.I.C.

B. A. Ellis, O.B.E., M.A., F.R.I.C.

J. C. Gage, B.Sc., Ph.D., F.R.I.C.

D. C. Garratt, Ph.D., D.Sc., F.R.I.C.

G. S. Hartley, D.Sc.

J. G. Reynolds, F.Inst.Pet., F.R.I.C.

G. Taylor, O.B.E., F.R.I.C.

*Tropical Products Institute*

*Plant Protection Ltd.*

*Department of the Government Chemist*

*Imperial Chemical Industries Ltd. (Industrial Hygiene Laboratories)*

*Boots Pure Drug Co. Ltd.*

*Research Centre of Fisons Pest Control Ltd.*

*"Shell" Research Ltd.*

*Public Analyst, Official Agricultural Analyst and Consulting Chemist*

Miss C. H. Tinker (Secretary)

TERMS OF REFERENCE—"To consider the analytical problems that arise, or may arise, in connection with the presence of pesticide residues in foodstuffs; and to advise as to analytical procedures for the detection and determination of any such residues or their breakdown products."

## PROGRESS OF WORK—

A full account of the programme of work of this Sub-Committee, which was re-constituted as a steering committee in May, 1958, will be found earlier in this Report (see p. 332).

## TRACE ELEMENTS IN FERTILISERS AND FEEDING-STUFFS SUB-COMMITTEE

## CONSTITUTION—

C. J. Regan, B.Sc., F.R.I.C. (Chairman)	Formerly Chemist-in-Chief, London County Council
S. M. Boden, B.Sc., A.R.I.C.	Ministry of Agriculture, Fisheries and Food, National Agricultural Advisory Service
L. Brealey, B.Sc.	Boots Pure Drug Co. Ltd.
S. G. Burgess, B.Sc., Ph.D., F.Inst.Pet., M.Inst.S.P., F.R.I.C.	London County Council
J. H. Hamence, M.Sc., Ph.D., F.R.I.C.	Public Analyst, Official Agricultural Analyst and Consulting Chemist
R. F. Milton, B.Sc., Ph.D., M.I.Biol., F.R.I.C.	Analytical and Consulting Biochemist
R. L. Mitchell, B.Sc., Ph.D., F.R.S.E., F.R.I.C.	Macaulay Institute for Soil Research
J. B. E. Patterson, M.Sc., F.R.I.C.	Ministry of Agriculture, Fisheries and Food, National Agricultural Advisory Service
W. L. Sheppard, A.R.I.C.	Unilever Ltd.
J. Williams, B.Sc., Ph.D., F.R.I.C.	Spillers Ltd.
Miss C. H. Tinker (Secretary)	

TERMS OF REFERENCE—“To devise appropriate methods of analysis (to be recommended for inclusion in the Regulations under the Fertilisers and Feeding Stuffs Act, 1926) for the determination of boron, cobalt, copper, fluorine, iodine, iron, magnesium, manganese, molybdenum, selenium and zinc, which can be expected to be present in fertilisers and feeding stuffs.”

## PROGRESS OF WORK—

As a result of a number of collaborative tests during the year, methods for the end-determination of 10 of the 11 elements mentioned above have been tentatively adopted. All of these are based on published methods, but modifications have been found necessary to cater for the various types of materials usually encountered in practice. Methods for magnesium are still under test, but it is hoped to recommend a method in the near future. Suitable methods for the preliminary treatment of the sample have yet to be devised for some of the elements.

In addition to the 11 elements included in the terms of reference, it was decided to prepare methods for chromium and nickel, since these metals are likely to be present in sewage sludges used as fertilisers: methods have been tentatively adopted.

The Sub-Committee will publish a comprehensive report of its findings. However, since it also acts as the Trace Elements Panel of the new Additives in Animal Feeding Stuffs Sub-Committee, the relevant sections of its final report will be made available to that committee as soon as possible.

## VITAMIN-E PANEL

## CONSTITUTION—

A. L. Bacharach, M.A., F.R.I.C. (Chairman)	Consulting Chemist
J. Green, B.Sc., Ph.D., F.R.I.C. (Honorary Technical Secretary)	Vitamins Ltd.
V. H. Booth, Ph.D.	Agricultural Research Council (Dunn Nutritional Laboratory)
A. R. Moss, B.Sc., Ph.D.	Roche Products Ltd.
H. N. Ridyard, B.Sc., A.K.C., F.R.I.C.	Research Association of British Flour Millers
P. W. Russell Eggitt, B.Sc., Ph.D., A.R.I.C.	Spillers Ltd.
C. A. Shacklady, B.Sc., A.R.I.C.	J. Bibby & Sons Ltd.
P. Stross, B.Sc.	British Drug Houses Ltd.
G. Walley, B.Sc., F.R.I.C.	Unilever Ltd.
R. J. Ward, B.Sc., Ph.D., A.R.I.C.	Medical Research Council (Dunn Nutritional Laboratory)
E. C. Wood, B.Sc., Ph.D., A.R.C.S., F.R.I.C.	Public Analyst and Consulting Chemist
Miss C. H. Tinker (Secretary)	



TERMS OF REFERENCE—"To survey the methods already proposed for the estimation of Vitamin E and to recommend to the [Vitamins] Sub-Committee a standard method or methods."

PROGRESS OF WORK—

As mentioned earlier in this Report (see p. 331), the Panel has completed its programme and its Report will be published in the summer. The Panel has now been disbanded.

REPORT OF THE P.S. - S.A.C. JOINT COMMITTEE ON  
METHODS OF ASSAY OF CRUDE DRUGS

MAIN COMMITTEE

CONSTITUTION—

*Representing the Pharmaceutical Society of Great Britain—*

K. R. Capper, Ph.D., B.Pharm., F.P.S., D.I.C. *Pharmaceutical Society of Great Britain*  
(Chairman)

J. W. Fairbairn, B.Sc., Ph.D., F.P.S., F.L.S., *University of London (School of Pharmacy)*  
F.R.I.C.

R. Higson, F.P.S. *Ministry of Health, Supplies Division*

W. Mitchell, B.Sc., Ph.D., F.R.I.C. *Stafford Allen & Sons Ltd.*

R. E. Stuckey, Ph.D., D.Sc., F.P.S., F.R.I.C. *British Drug Houses Ltd.*

*Representing the Society for Analytical Chemistry—*

C. A. Johnson, B.Sc., B.Pharm., F.P.S., A.R.I.C. *Boots Pure Drug Co. Ltd.*

H. C. Macfarlane, A.R.T.C.S., F.R.I.C. *Analytical and Consulting Chemist*

D. Watt, F.P.S. *T. & H. Smith Ltd.*

D. C. Garratt, Ph.D., D.Sc., F.R.I.C. *Chairman of the Analytical Methods Committee*

*Representing the Tropical Products Institute—*

A. J. Feuell, B.Sc., Ph.D., A.R.I.C. *Tropical Products Institute*

Miss C. H. Tinker, B.Sc., Ph.D., A.R.I.C. *Secretary to the Analytical Methods Committee*  
(Secretary)

Miss A. M. Parry, B.Sc. *Assistant Secretary to the Analytical Methods*  
(Assistant Secretary) *Committee*

TERMS OF REFERENCE—"To prepare standard methods of assay of crude drugs and kindred materials."

PROGRESS OF WORK—

The Main Committee, set up in 1956, acts as a steering committee and the work of preparing methods of assay is delegated to working panels. The progress of work in each of the five panels in being at present is reported below.

When the Joint Committee was appointed, a lengthy programme of work was planned and, when opportunity permits, further panels will be appointed.

PANEL 1: *Digitalis purpurea*—CHEMICAL METHOD

CONSTITUTION—

Professor H. Brindle, M.Sc., F.P.S., F.R.I.C. *Emeritus Professor of Pharmacy, University of*  
(Chairman) *Manchester*

G. E. Foster, B.Sc., Ph.D., F.R.I.C. *Wellcome Chemical Works*

G. J. Rigby, M.Sc., Ph.D., Dip.Bact. *University of Manchester (Department of Phar-*  
*macy)*

K. L. Smith, M.P.S. *Boots Pure Drug Co. Ltd.*

Professor J. P. Todd, Ph.D., F.P.S., F.R.I.C. *Royal College of Science and Technology, Glasgow*  
(School of Pharmacy)

W. D. Williams, B.Pharm., Ph.D., F.P.S., *Royal College of Science and Technology, Glasgow*  
A.R.I.C. (School of Pharmacy)

Miss A. M. Parry (Secretary)

TERMS OF REFERENCE—"To investigate chemical methods for the assay of digitalis and its preparations and to attempt to correlate them with the biological method of assay."

PROGRESS OF WORK—

The Panel is continuing its investigations into chemical methods of assay of the glycosides present in digitalis, with a view to establishing a correlation between the results obtained chemically and the biological activity of the drug.

## PANEL 2: CAPSICUM—CAPSAICIN CONTENT

## CONSTITUTION—

H. B. Heath, M.B.E., B.Pharm., F.P.S. ( <i>Chairman</i> )	<i>Stafford Allen &amp; Sons Ltd.</i>
E. A. Elsbury, F.R.I.C.	<i>Parke, Davis &amp; Co. Ltd.</i>
Miss B. M. Luckett	<i>W. J. Bush &amp; Co. Ltd.</i>
C. A. MacDonald, B.Sc., F.R.I.C.	<i>Evans Medical Supplies Ltd.</i>
G. R. A. Short, F.P.S.	<i>W. J. Bush &amp; Co. Ltd.</i>
D. O. Singleton, B.Sc.	<i>Beecham Maclean Ltd.</i>
Miss A. M. Parry ( <i>Secretary</i> )	

TERMS OF REFERENCE—"To investigate methods of assay of capsicum and capsicum products with particular reference to the determination of the capsaicin content."

## PROGRESS OF WORK—

The Panel has now completed its investigations into methods for the determination of capsaicin in Capsicum, B.P.C., and in the oleoresin, tincture and ointment specified in the B.P.C., and has prepared a report, which will shortly be published.

The recommended methods include details of the preliminary treatment of the various samples, of two extraction procedures, one chromatographic and the other an ether-alkali partition extraction, and of three methods for the determination of capsaicin. Of these, a spectrophotometric method, in which the difference in absorption characteristics of capsaicin in acid and in alkaline solutions is utilised, gives the most reproducible results. The other two methods are a direct spectrophotometric procedure and a colorimetric method based on the coupling reaction between diazobenzenesulphonic acid and capsaicin.

Work is proceeding on other official preparations, on the assessment of synthetic capsaicins and on formulated products of capsicum. The Panel will later turn its attention to paprika and its preparations.

## PANEL 3: ANTHRAQUINONE DRUGS

## CONSTITUTION—

W. Mitchell, B.Sc., Ph.D., F.R.I.C. ( <i>Chairman</i> )	<i>Stafford Allen &amp; Sons Ltd.</i>
J. W. Fairbairn, B.Sc., Ph.D., F.P.S., F.L.S. F.R.I.C.	<i>University of London (School of Pharmacy)</i>
C. A. Johnson, B.Sc., B.Pharm., F.P.S., A.R.I.C.	<i>Boots Pure Drug Co. Ltd.</i>
S. C. Jolly, B.Sc., B.Pharm., F.P.S., A.R.I.C.	<i>Pharmaceutical Society of Great Britain</i>
H. A. Ryan, B.Sc., F.R.I.C.	<i>Westminster Laboratories Ltd.</i>
W. Smith, B.Sc., F.R.I.C.	<i>Allen &amp; Hanburys Ltd.</i>
R. V. Swann, B.Sc., F.R.I.C.	<i>Allen &amp; Hanburys Ltd.</i>
Miss A. M. Parry ( <i>Secretary</i> )	

TERMS OF REFERENCE—"To investigate methods for estimating the purgative activity of drugs and preparations of drugs containing anthraquinone derivatives, with a view to recommending standard methods of assay."

## PROGRESS OF WORK—

On taking up an appointment overseas, Dr. J. M. Rowson resigned from the Chair and was succeeded by Dr. W. Mitchell.

After exploratory work on the comparison between the activity of Alexandrian and Tinnevely senna pods, determined by biological assay, and their sennoside contents, found by chemical methods, the Panel is continuing collaborative tests on the latter; a spectrophotometric modification of the method is being investigated as a possible alternative to the colorimetric determination.

The Panel is most grateful to Westminster Laboratories Ltd. for providing supplies of pure Sennoside B for use in its work.

## PANEL 4: RAUWOLFIA

## CONSTITUTION—

C. A. Johnson, B.Sc., B.Pharm., F.P.S., A.R.I.C. ( <i>Chairman</i> )	<i>Boots Pure Drug Co. Ltd.</i>
T. Davies, B.Sc., A.R.I.C.	<i>CIBA Laboratories Ltd.</i>

Miss B. Gartside, B.Pharm.  
J. J. Lewis, M.Sc., F.P.S.

*Pharmaceutical Society of Great Britain*  
*University of Glasgow (Department of Materia*  
*Medica and Therapeutics)*  
*Riker Laboratories Ltd.*

A. W. Peacock, B.Pharm., F.P.S.  
Miss A. M. Parry (*Secretary*)

TERMS OF REFERENCE—"To investigate methods of assay for rauwolfia and its preparations with particular regard to the content of reserpine and related alkaloids."

PROGRESS OF WORK—

The Panel has investigated two procedures for the assay of *Rauwolfia serpentina*, both based on published work. The first, a colorimetric procedure for the determination of reserpine and related alkaloids, shows promise, and good replication within a single laboratory can be obtained; however, some further modification to the method is still required to reduce a certain amount of inter-laboratory variation. It is hoped that a report recommending a method of assay will be published shortly. The second procedure, based on the ultra-violet absorption characteristics of trimethoxybenzoic acid and trimethoxycinnamic acid, has been abandoned, since it has been shown that the latter acid is subject to rapid change when its solutions are exposed to daylight. A paper giving details of this work is being published in the April issue of the *Journal of Pharmacy and Pharmacology* under the authority of the Main Committee.

The Panel is grateful to Messrs. CIBA Laboratories Ltd., and Messrs. Riker Laboratories Ltd., for their continued gifts of alkaloids and raw materials.

PANEL 5: LONCHOCARPUS AND DERRIS

CONSTITUTION—

R. F. Phipers, B.Sc., Ph.D.  
(*Chairman*)

*The Cooper Technical Bureau*

R. Buckley, B.Sc., A.R.I.C.

*Plant Protection Ltd.*

J. A. Dawson, B.Sc., A.R.I.C.

*Tropical Products Institute*

W. E. Drinkwater, F.R.I.C.

*Boots Pure Drug Co. Ltd.*

R. V. Foster, M.Sc., A.R.I.C.

*The Cooper Technical Bureau*

S. C. Jolly, B.Sc., B.Pharm., F.P.S., A.R.I.C.

*Pharmaceutical Society of Great Britain*

J. T. Martin, B.Sc., D.Sc., F.R.I.C.

*University of Bristol (Long Ashton Research Station)*

R. A. Rabnott

*Analytical and Consulting Chemist*

D. V. Richmond, B.Sc.

*University of Bristol (Long Ashton Research Station)*

F. H. Tresadern

*Stafford Allen & Sons Ltd.*

Miss A. M. Parry (*Secretary*)

TERMS OF REFERENCE—"To investigate methods of assay of derris, lonchocarpus and their preparations, with particular reference to the determination of their rotenone content."

PROGRESS OF WORK—

Since its formation in July, 1957, the Panel has carried out a considerable amount of collaborative work on investigations into a chemical method for the determination of rotenone in ground lonchocarpus root, and a report on the recommended method is now being prepared for publication. It was realised that rotenone is not the only constituent of lonchocarpus exercising a biological effect, but it was considered desirable to find an acceptable method of determination for use in commercial transactions.

The method to be recommended is based on that published in the British Veterinary Codex, 1953, but a number of modifications have been made, including the introduction of a preliminary alkali-washing procedure for the removal of phenolic and emulsifying constituents, which greatly facilitates the crystallisation of the rotenone.

Work is now proceeding on methods for the determination of rotenone in formulated products used for pest control, and eventually the Panel hopes to examine methods of analysis that will estimate the insecticidal value of all the biologically-active materials present.

## APPENDIX I

THE SOCIETY FOR ANALYTICAL CHEMISTRY ANALYTICAL METHODS TRUST  
ACCOUNTS FOR THE YEAR ENDED OCTOBER 31ST, 1958*Income and Expenditure Account for the Year Ended October 31st, 1958*

1957				1957		
£	£	£	£	£	£	
	Rent, Light, Heat and			5900	Subscriptions from Industry ..	5394
289	Telephone .. ..	222		10	Interest from Investments (gross) ..	10
2630	Salaries .. ..	2785		28	Bank Deposit Interest .. ..	622
487	Office Equipment ..	119				
184	Printing and Stationery	222				
20	Travelling Expenses ..	12				
107	Expenses of Meetings ..	76				
21	Audit Fee .. ..	21				
	Postage and Petty Ex-					
	penses .. ..	105				
3816			3562			
958	Scholarship Grant ..		524			
	Excess of Income over					
	Expenditure for the					
	year ended October					
	31st, 1958, transferred					
	to Accumulated Fund		1940			
1164						
<u>£5938</u>		<u>£6026</u>		<u>£5938</u>		<u>£6026</u>

*Accumulated Fund*

1957				1957		
£	£	£	£	£	£	
10,854	Balance carried to Balance Sheet	12,794		9690	Balance at October 31st, 1957 ..	10,854
					Excess of Income over Expendi-	
					ture for the year ended October	
				1164	31st, 1958 .. .. .	1940
<u>£10,854</u>		<u>£12,794</u>		<u>£10,854</u>		<u>£12,794</u>

*Balance Sheet at October 31st, 1958*

1957				1957		
£	£	£	£	£	£	
10,854	Accumulated Fund:				Investments (at Cost):	
	Balance at October 31st, 1958 ..	12,794			£100 Ceylon Govern-	
914	Sundry Creditors .. .. .	121			ment 3½% Stock,	
				61	1934-59 .. .. .	61
					£100 3½% Conversion	
				83	Stock .. .. .	83
				100	£100 3½% War Stock	100
				244	(Market Value at	
					31.10.58, £250)	244
				31	Sundry Debtors ..	169
					Cash at Banks:	
				7000	Deposit Account ..	7000
				4493	Current Account ..	5502
				11,493		
<u>£11,768</u>		<u>£12,915</u>		<u>£11,768</u>		<u>£12,915</u>

*Report of the Auditors to the Trustees of The Society for Analytical Chemistry Analytical Methods Trust Fund*

We have examined the above Balance Sheet which in our opinion gives a true and fair view of the state of affairs of the Trust at 31st October, 1958.

10 New Court,  
Lincoln's Inn,  
LONDON, W.C.2.  
17th April, 1959.

(Signed) RIDLEY, HESLOP & SAINER,  
Chartered Accountants,  
Auditors.

*Schedule of Investments at October 31st, 1958*

	Nominal Amount	Cost	Market Value 31.10.58	Income Received Gross
Ceylon Government 3½% Stock .. .. .	100	61	96	3
3½% Conversion Stock .. .. .	100	83	87	4
3½% War Stock .. .. .	100	100	67	3
		<u>£244</u>	<u>£250</u>	<u>£10</u>

## APPENDIX II

## SUBSCRIBERS TO THE TRUST FUND DURING 1958

Albright & Wilson Ltd.	Horlicks Ltd.
James Anderson & Co. (Colours) Ltd.	Huntley & Palmers Ltd.
The Associated Ethyl Company Ltd.	Iford Ltd.
J. Bibby & Sons Ltd.	Imperial Chemical Industries Ltd.
A. Boake, Roberts & Co. Ltd.	Laporte Chemicals Ltd.
Boots Pure Drug Co. Ltd.	J. Lyons & Co. Ltd.
Bovril Ltd.	Macfarlane Lang & Co. Ltd.
The British Aluminium Co. Ltd.	May & Baker Ltd.
British Celanese Ltd.	The Metal Box Company Ltd.
The British Drug Houses Ltd.	The Millers' Mutual Association
British Glues & Chemicals Ltd.	National Coal Board
British Oxygen Research & Development Ltd.	Peek, Frean & Co. Ltd.
Brotherton & Co. Ltd.	Pilkington Brothers Ltd.
Cadbury Brothers Ltd.	Procea Products Ltd.
Cooper, McDougall & Robertson Ltd.	Quaker Oats Ltd.
The Distillers Company Ltd.	Rowntree & Co. Ltd.
Dunlop Research Centre	"Shell" Research Ltd.
The Electricity Council	John & E. Sturge Ltd.
Glaxo Laboratories Ltd.	Unilever Ltd.
Arthur Guinness, Son & Co. (Park Royal) Ltd.	Vitamins Ltd.
H. J. Heinz Ltd.	Wallace & Tiernan Ltd.
Hopkin & Williams Ltd.	The Wellcome Foundation Ltd.
	Weston Research Laboratories Ltd.

# X-Ray Fluorescence Analysis

## A Review

By F. BROWN

(Research Department, Imperial Chemical Industries Ltd., Billingham Division, Billingham, Co. Durham)

When an element is irradiated with X-rays of sufficiently high energy, secondary, or fluorescence, X-rays are emitted that are characteristic of the element. Measurement of the intensity and wavelength of fluorescence radiation is now a well established method of analysis and has been applied to the determination of the elements from sodium (11) to uranium (92) in powder, liquid or metal samples. Coefficients of variation of about 1 per cent. in the concentration range 5 to 100 per cent. and of 5 per cent. in the 0.1 to 1 per cent. range can usually be obtained, and, in favourable instances, determinations at the parts per million level can be made. The method is rapid, independent of the chemical combination of the element and non-destructive in the sense that the specimen examined is not destroyed, although some specimen preparation may be necessary.

### X-RAY SPECTRA

THE origin and general characteristics of X-ray spectra are well known; the features of particular importance to X-ray spectrometry may be summarised as follows.

When a stream of electrons is stopped by the target of an X-ray tube, part of the primary X-radiation emitted is in the form of a continuous spectrum covering a broad wavelength range (see Fig. 1).<sup>1</sup> The kinetic energy of the incident electrons is dissipated by successive collisions with the atoms of the target material and part of the energy lost in each collision is re-emitted as an X-ray photon of definite frequency.

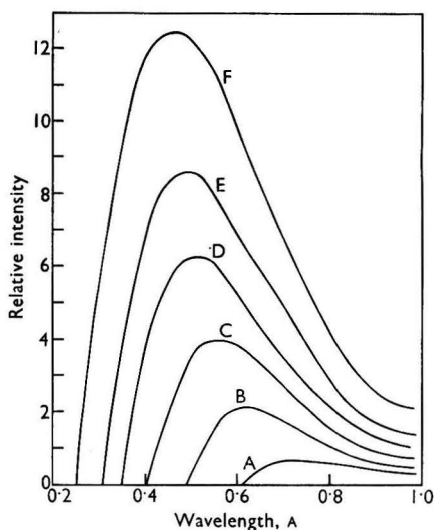

Fig. 1. Variation in the spectral distribution of tungsten continuous radiation with tube voltage<sup>1</sup>: curve A, 20 kV; curve B, 25 kV; curve C, 30 kV; curve D, 35 kV; curve E, 40 kV; curve F, 50 kV

The continuum terminates abruptly on the short-wavelength side and this limiting radiation is emitted when an electron loses all its energy in a single collision. The wavelength of

the spectral limit is related to the accelerating voltage applied to the X-ray tube, which limits the kinetic energy of the electrons, by the equation—

$$Ve = \frac{hc}{\lambda_{\min.}} \quad \dots \quad (1)$$

where  $V$  is the X-ray tube voltage,  $e$  is the charge on the electron,  $h$  is Planck's constant,  $c$  is the velocity of light and  $\lambda_{\min.}$  is the wavelength of the spectral limit.

An increase in tube voltage results in an increase in the total energy emitted and a movement of the spectral distribution towards shorter wavelengths; the total energy emitted also increases with increasing atomic number of the target material.

The primary characteristic spectrum is made up of radiations, or lines, that have discrete wavelengths and is obtained in addition to, and superimposed on, the continuum when the incident electrons have sufficient energy to eject an electron from one of the inner shells of a target atom. The resulting ionised atom regains stability by successive electron transitions from states of higher to lower energy, and the energy released by each transition appears as a spectral line having a frequency dependent on the difference in energy of the electron in the initial and final states.

K-series lines are obtained when a K electron is ejected and arise by electron transitions from outer shells to the K shell. The L electrons are grouped according to their binding energy into three sub-shells,  $L_I$ ,  $L_{II}$  and  $L_{III}$ , and each sub-shell has an associated spectral series. The complete M spectrum is made up of five series corresponding to the five sub-shells.

The relative simplicity of characteristic X-ray spectra is explained by the limited number of energy levels in the atom, together with certain prohibited transitions. From Fig. 2,<sup>2</sup> which shows the permitted transitions between energy levels in a uranium atom, it is evident that the complexity of a complete spectral series depends on the number of energy levels in the main shell and therefore increases in the order  $K \rightarrow L \rightarrow M$ . As the atomic number decreases, the outer shells successively disappear and the characteristic X-ray spectrum becomes simpler.

The frequency,  $\nu$ , of a spectral line belonging to a particular series varies regularly with atomic number,  $Z$ . This relationship is expressed by Moseley's law—

$$\nu^{\frac{1}{2}} = K(Z - \sigma) \quad \dots \quad (2)$$

where  $K$  is a proportionality constant and  $\sigma$  is another constant, the value of which depends on the series.

The characteristic X-ray spectrum of an element can also be excited by X-rays if this primary X-radiation is sufficiently energetic to ionise an inner shell. The energy needed to eject an electron completely from the atom is greater than that liberated as secondary X-radiation by an electron transition from the outermost shell to the ionised shell. Since this transition gives rise to the line of highest frequency in the series, it follows that all the emitted lines will be of lower frequency, or longer wavelength, than that of the absorbed radiation. The phenomenon is therefore termed fluorescence.

If the wavelength of X-radiation incident on an element is gradually decreased, the X-ray photons become progressively more energetic until, at a certain wavelength, they are able to ionise one of the inner shells and produce the characteristic lines of a spectral series. At this critical wavelength there is a sharp rise (the absorption edge) in the absorption of X-radiation by the element. There is one absorption edge associated with each energy level, and, as the wavelength of the incident radiation is decreased, there is successive ionisation of the  $M_V$  to  $M_I$ ,  $L_{III}$ ,  $L_{II}$ ,  $L_I$  and, finally, the K shell, with the appearance of lines of the corresponding spectral series (see Fig. 3).<sup>3</sup> The wavelengths of some spectral lines and absorption edges of several elements are shown in Table I.<sup>4</sup>

A spectral series will be excited by primary continuous radiation only when the wavelength limit,  $\lambda_{\min.}$ , equation (1), is shorter than the absorption edge of the series. Since  $\lambda_{\min.}$  depends on the voltage applied to the X-ray tube, there is a critical excitation potential below which the lines of a spectral series will not be excited by primary radiation. This critical value can be calculated for any series by substituting the appropriate absorption-edge wavelength for  $\lambda_{\min.}$  in equation (1).

The critical excitation potential for any given series increases progressively with atomic number. The K-series lines of sodium (11) and uranium (92) appear at critical potentials of 1.07 and 115 kV, respectively; uranium L lines appear at 21.7 kV. X-ray tubes currently

available have a maximum rating of 50 or 60 kV and are therefore unable to excite the K spectra of elements of high atomic number. The K spectra are generally used for elements up to about barium (56) and the L spectra from lanthanum (57) to uranium (92).

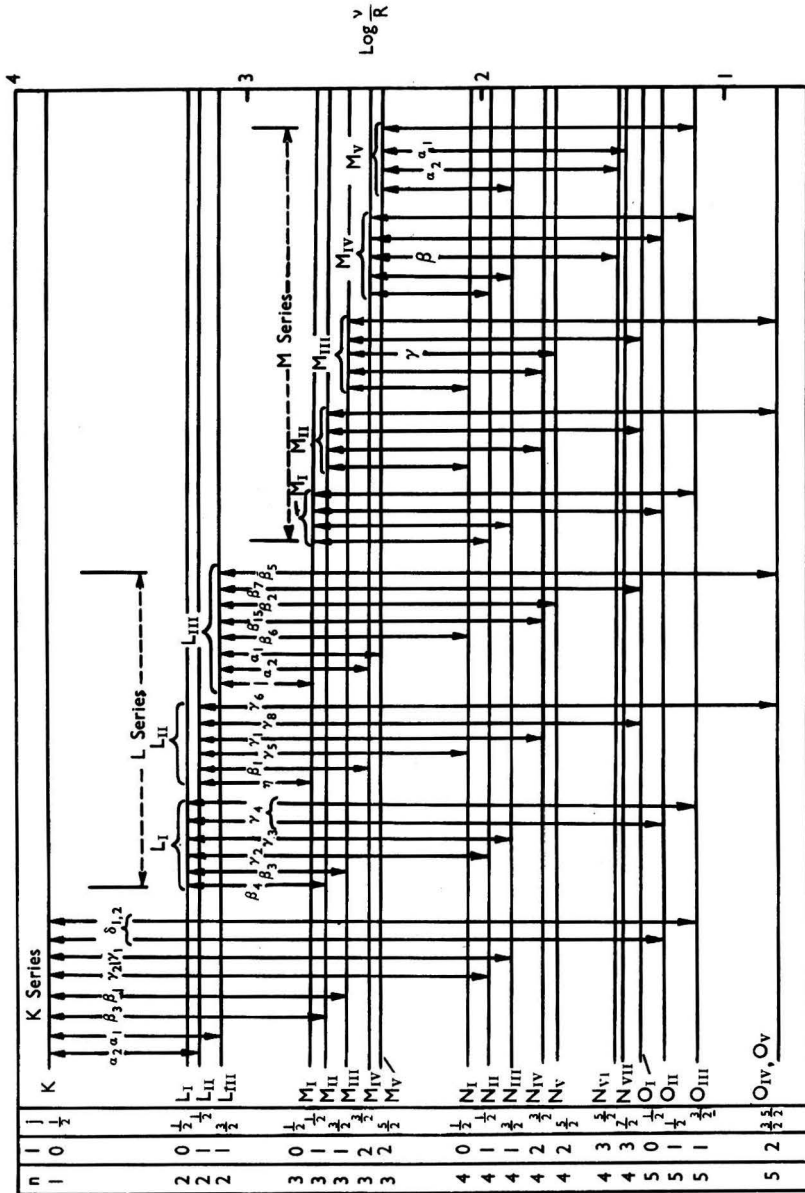

Fig. 2. X-ray energy level diagram for uranium-92, showing the transitions permitted by the selection rules  $\Delta l = \pm 1$ ;  $\Delta j = \pm 1, 0$

DEVELOPMENT OF X-RAY SPECTROMETRY

In 1908, Barkla and Sadler<sup>5</sup> showed that secondary X-rays, which had a constant coefficient of absorption and were therefore termed "homogeneous," were emitted when an element was bombarded with a beam of primary X-rays.

Friedrich, Knipping and Laue<sup>6</sup> demonstrated that a crystal could act as a grating for the diffraction of X-rays, and W. L. Bragg<sup>7</sup> suggested that such diffraction could be regarded as a



reflection of the electromagnetic radiation from well populated layers of atoms in the crystal. W. H. Bragg used the cleavage face of a rock salt crystal to reflect X-rays emitted from the platinum target of an X-ray tube. The crystal was placed on the prism table of a spectrometer and the radiation was detected by using an ionisation chamber mounted on the spectrometer arm. By rotating the crystal, in order to vary the angle of incidence, at half the angular speed of the ionisation chamber, he was able to obtain the first X-ray spectrum. Further work on the reflection of radiation from crystal planes led to Bragg's law—

$$n\lambda = 2d \sin \theta \quad \dots \quad (3)$$

which relates the wavelength of the reflected radiation,  $\lambda$ , the angle of incidence,  $\theta$ , on atomic planes of interplanar spacing  $d$ , and the order of reflection,  $n$ . Reflection will occur only when equation (3) is satisfied, so a heterogeneous beam of X-rays can be analysed by measuring the angles at which there is reflection from atomic layers of known interplanar spacing.

TABLE I

## WAVELENGTHS OF SOME SPECTRAL LINES AND ABSORPTION EDGES OF CERTAIN ELEMENTS

These wavelengths have been taken from Compton and Allison's Tables<sup>4</sup> and converted from kXU to A by using the factor 1.00202

Element	Atomic number	K series				L series				
		$\alpha_1$ A	$\alpha_2$ A	$\beta_1$ A	$\lambda_{\text{abs.}}$ A	$\alpha_1$ A	$\alpha_2$ A	$\beta_1$ A	$\gamma_1$ A	$\lambda_{\text{abs.}}(L_{\text{III}})$ A
Magnesium ..	12	9.889		9.558	9.515	—	—	—	—	—
Sulphur ..	16	15.372	5.375	5.031	5.019	—	—	—	—	—
Titanium ..	22	2.749	2.752	2.514	2.496	—	—	—	—	—
Copper ..	29	1.541	1.544	1.392	1.380	—	—	—	—	—
Niobium ..	41	0.746	0.750	0.666	0.653	5.724	5.730	5.491	5.035	5.223
Iodine ..	53	0.433	0.438	0.384	0.374	3.148	3.157	2.937	2.583	2.719
Tungsten ..	74	0.209	0.214	0.184	0.179	1.476	1.487	1.282	1.099	1.214
Uranium ..	92	0.127	0.131	0.112	0.107	0.911	0.922	0.720	0.615	0.722

The next stage in the development of X-ray spectrometry was due to Moseley,<sup>8</sup> who investigated the spectra emitted by several elements that, in turn, were used as the target of an X-ray tube. The radiation was dispersed by using a crystal of potassium ferrocyanide and was recorded on a photographic plate. The relationship he found between the frequency of a spectral line of a particular series and the atomic number of the element was referred to in the previous section, equation (2).

The potentialities of X-ray emission spectrometry as an analytical method were evident from Moseley's work, and X-ray spectra were later used to identify the elements masurium (43), illinium (61), hafnium (72) and rhenium (75).

In order to use primary X-ray spectra for analysis, the specimen must be plated or smeared on to the target of the X-ray tube. This has several disadvantages: the tube must be re-evacuated when the specimen is changed; the heating effect of the electron stream may cause chemical reaction, selective volatilisation or melting; when photographic recording is used, weak lines may be difficult to detect because of the blackening effect of the continuous radiation. However, in spite of these drawbacks the technique did achieve some success<sup>9</sup> to <sup>14</sup> and is still used to-day.

Analysis by using fluorescence spectra avoids these difficulties because the specimen is placed outside the X-ray tube and no secondary continuum is obtained. The disadvantage is that fluorescence lines are much weaker than primary lines, and, since photographic recording was almost universally used in the early days, long exposures were often necessary. von Hevesy and his co-workers<sup>15</sup> first used fluorescence spectra for analysis, and other successful applications<sup>14,16,17</sup> have been reported.

The widespread application of X-ray fluorescence analysis is the direct result of improvements in X-ray tubes and the development of counter tubes as detectors. It has been found particularly useful in routine analysis and for determining closely related elements, for example, the rare earths, the noble metals, niobium and tantalum, and hafnium and zirconium, when other methods of analysis are difficult or time-consuming.

## GENERAL PRINCIPLES

The following description of a plane-crystal spectrograph, which is most generally used for analysis, is based on the instrument made by Philips Electrical Ltd., The Netherlands, and shown in Fig. 4.

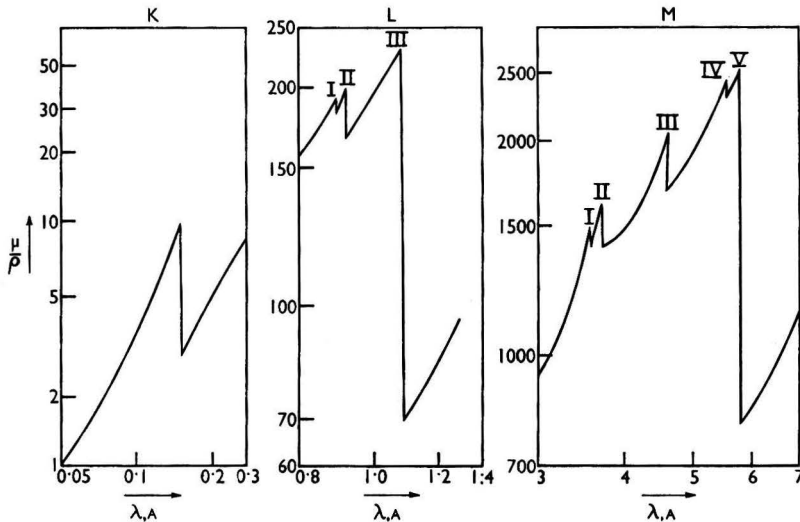

Fig. 3. Variation in the mass absorption coefficient ( $\mu/\rho$ ) with wavelength ( $\lambda$ ) in the regions of the K, L and M absorption edges<sup>a</sup>

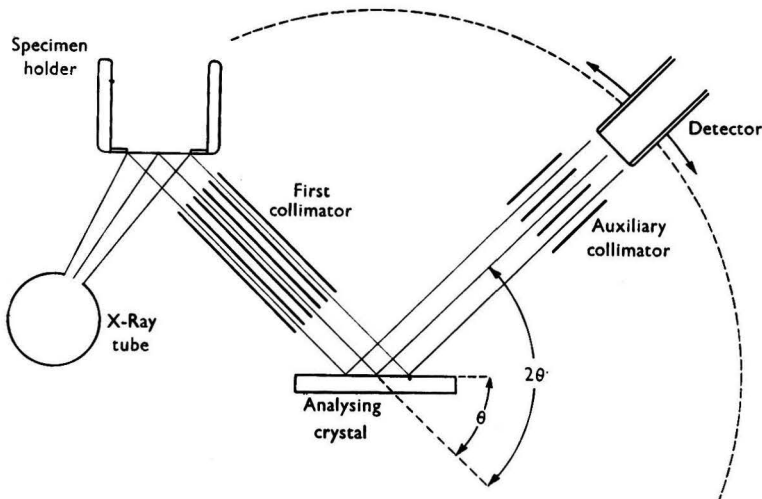

Fig. 5. Diagrammatic arrangement of the plane-crystal X-ray spectrograph

The arrangement for exciting, dispersing and detecting fluorescence radiation is shown diagrammatically in Fig. 5. The specimen in the specimen holder is irradiated from below with an unfiltered beam of primary X-rays, which causes the elements present to emit their characteristic fluorescence lines. Part of the fluorescence beam is collimated by a Soller slit system and directed on to the plane surface of the analysing crystal. The line radiations are reflected according to Bragg's law and pass through an auxiliary collimator to the detector, where the energy of the X-ray photons is converted into electrical impulses, or "counts." The impulses are then amplified and fed to an electronic counting panel, where they may be

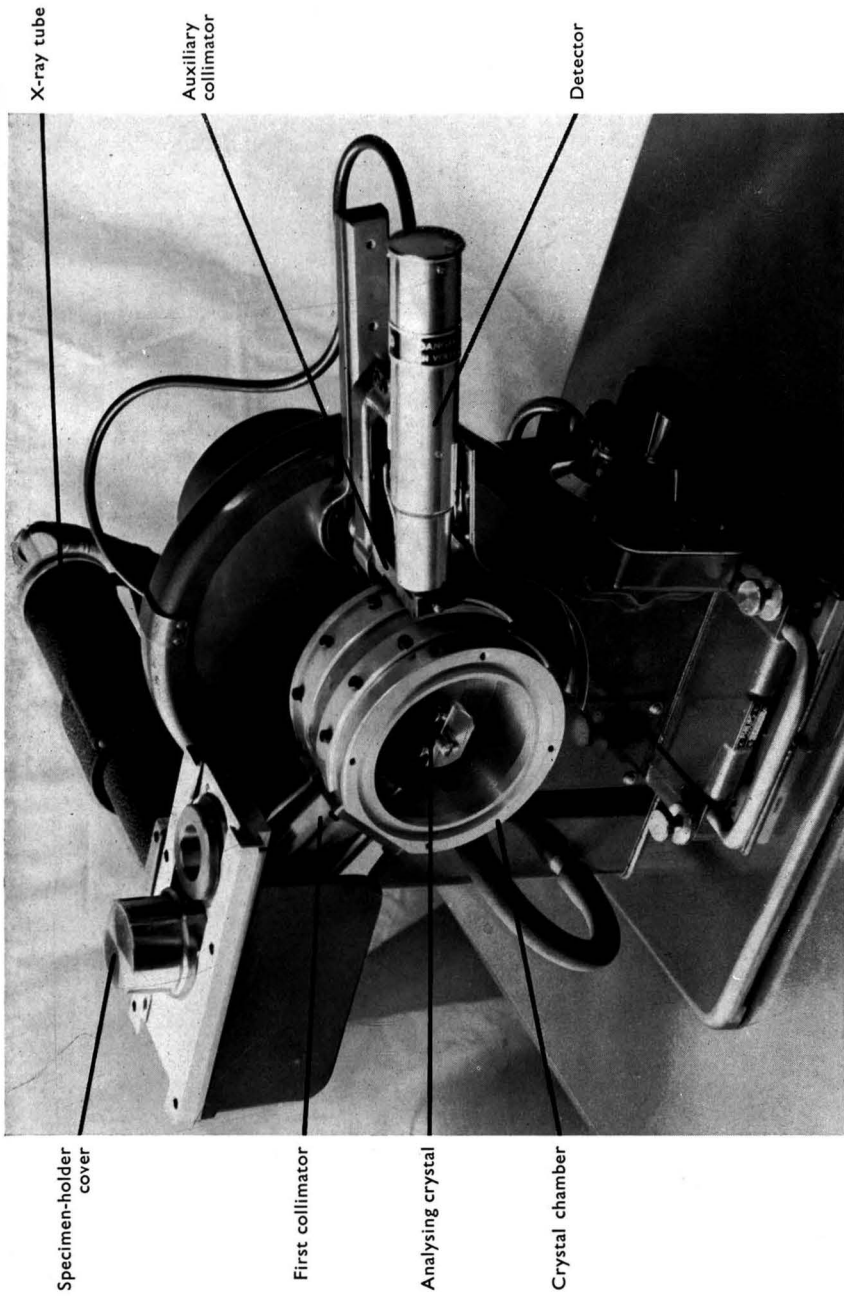

Fig. 4. Philips X-ray fluorescence spectrograph

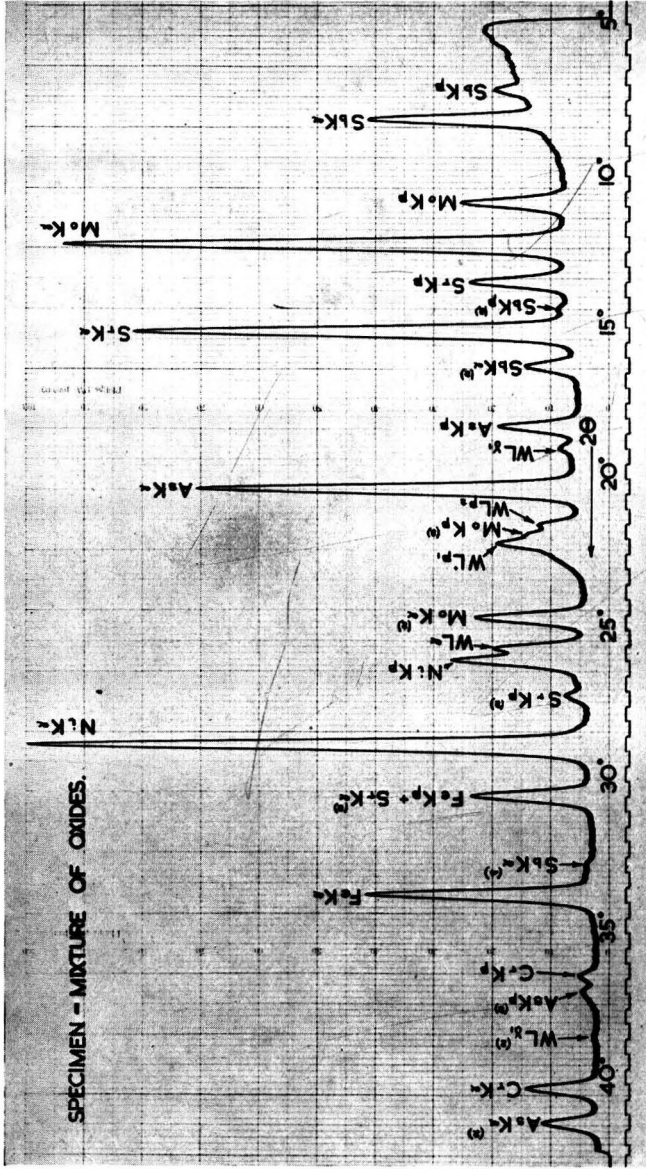

Fig. 6. Spectral scan of specimen containing 1 per cent. each of antimony, molybdenum, strontium, arsenic, nickel, iron and chromium, as oxides, in a silica matrix. Higher order reflections are shown by superscripts. Conditions: tungsten tube; 50KV; 20 mA; quartz crystal; scintillation counter at 950 volts; scan speed 1° (2θ) per minute

either integrated in a rate meter and recorded on a strip chart or else scaled down to units that can be visually observed on decatron scalars.

Intensity losses caused by absorption of the longer wavelength, or soft, X-rays by air can be reduced by evacuating the crystal chamber shown in Fig. 4. Absorption by air can be completely avoided by using a vacuum spectrograph, which permits the evacuation of the entire radiation path. Alternatively, the radiation path can be enclosed in a rubber bag and the air displaced by helium, which has a low absorption for soft X-rays.<sup>18</sup> Because of the shortage of helium, vacuum spectrographs are used in Europe for investigating radiation of longer wavelength (3 to 11 Å).

Focusing spectrographs that involve reflection from<sup>19</sup> and transmission through<sup>20</sup> a curved crystal have been described. Collimators are not required and the increase in intensity obtained by focusing the fluorescence lines makes the technique suitable for the analysis of small specimens (~1 mg). Plane and curved crystal arrangements have been described by Birks, Brooks and Friedman.<sup>21</sup>

For qualitative analysis it is usual to make a chart record. The angle,  $\theta$ , between the plane surface of the crystal and the incident fluorescence beam is gradually increased, and at certain well-defined angles the appropriate fluorescence lines are reflected. The detector and crystal are rotated, either manually or automatically, at angular speeds in the ratio 2 to 1 and the variation in the detected intensity is recorded on a moving chart as a series of peaks, corresponding to fluorescence lines, above a background, principally due to general scattering of the primary radiation by the specimen, as shown in Fig. 6. The angular position of the detector, in degrees of  $2\theta$ , is also recorded on the chart, so that a peak can be identified from the angle at which it appears. Tables have been published<sup>22</sup> listing characteristic lines, wavelengths and values of  $2\theta$  for use with various analysing crystals. Additional evidence for identification may be obtained from relative peak heights and by determining the voltage at which the peak appears, *i.e.*, the critical excitation potential.

For quantitative analysis it is necessary to measure the intensity of a characteristic line of the element. This can be done either by collecting counts for a certain period of time (fixed-time method) or by measuring the time necessary to collect a pre-set number of counts (fixed-count method).<sup>23</sup> It is usual to measure intensities at the peak angle and at a suitable background position close to the peak, and the net line intensity (peak *minus* background), in counts per second, is then related to the concentration of the element.

## EQUIPMENT

### X-RAY TUBES—

X-ray tubes are usually of the sealed-off type having tungsten, molybdenum or gold targets. They have power ratings of from 1 to 3 kW and operate with half- or full-wave rectification. With Philips equipment, constant intensity of primary radiation is achieved by high stabilisation of the tube current and voltage. The focus of the electron beam and the viewing angle are such that the primary beam is projected on to an area of about 500 sq. mm on the surface of the specimen. The tube window is of thin (~1 mm) beryllium, which will transmit X-rays of wavelength up to 3 to 4 Å.<sup>3</sup>

It has been stated previously that the excited secondary radiation does not include a continuous spectrum, but the primary continuum is scattered by the specimen and is chiefly responsible for the background radiation. Characteristic primary radiation from the target material, and from any impurities present in the target, is also scattered and will be recorded, so it would be unwise to choose, for example, a tungsten tube for the determination of tungsten in a specimen. The spectral purity of the primary beam can be investigated by scanning the complete spectral range, carbon or sugar, which give no recorded fluorescence lines, being used as a specimen.

### SPECIMEN HOLDER—

The Philips specimen holder is an aluminium cylinder 32 mm in diameter and 29 mm deep. The specimen is supported by a thin film of Mylar, and an aluminium mask restricts the area of specimen illuminated to a rectangle 18 mm × 27 mm. Specimen holders made from plastic material are available for the examination of acid or alkaline solutions.

## COLLIMATORS—

The fluorescence radiation is collimated either by a series of narrowly spaced metal plates or a bundle of tubes. The angular divergence of the rays that reach the crystal is limited by the first collimator (see Fig. 5). The auxiliary collimator is coarser and is particularly useful at very low values of  $\theta$  for preventing radiation that has not been reflected by the crystal from reaching the detector.

The width of a spectral line depends on the degree of collimation. Increased resolution can be obtained by decreasing the separation of the metal plates or by increasing the length of a collimator, but this is achieved at the expense of intensity. The effects of various collimating systems on line intensities, line profiles and line-to-background intensity ratios have been investigated by Campbell, Leon and Thatcher.<sup>24</sup>

## ANALYSING CRYSTALS—

According to Bragg's law, there is a theoretical upper limit of  $2d$  for the wavelength that can be reflected from a crystal of interplanar spacing  $d$ , and this limiting radiation will be reflected when  $2\theta$  is  $180^\circ$ . This angle is beyond the range of X-ray spectrographs, and, in addition, the intensity of reflected radiation decreases rapidly with increasing angle, so it is usual to select a crystal having an interplanar spacing such that the desired radiation is reflected in the angular ( $2\theta$ ) range  $10^\circ$  to  $100^\circ$ . The interplanar spacing of the crystal also determines the degree of dispersion of the spectral lines; for maximum dispersion, the crystal having the least spacing should be used.

The crystal should be large enough to accept at small angles all the radiation transmitted by the first collimator and must emit no fluorescence lines of its own that would overlap the spectral lines of interest.

Some examples of the crystals used as analysers are shown in Table II.

TABLE II  
TYPICAL ANALYSING CRYSTALS

Crystal	Reflecting plane	Interplanar spacing (d), Å
Topaz .. .. .	303	1.356
Lithium fluoride .. .. .	200	2.014
Sodium chloride .. .. .	200	2.821
Calcium fluoride .. .. .	111	3.16
Quartz .. .. .	10 $\bar{1}$ 1	3.343
Ethylenediamine D- tartrate .. .. .	—	4.404
Ammonium dihydrogen orthophosphate .. .. .	—	5.325
Gypsum .. .. .	020	7.60
Mica .. .. .	002	9.963

## DETECTORS—

Geiger, proportional and scintillation counters<sup>25 to 29</sup> have replaced photographic film for the detection of fluorescence X-radiation. The spectral sensitivity of each type varies with wavelength, as shown in Fig. 7,<sup>30</sup> and the choice of a detector is governed primarily by the radiation to be detected.

The Geiger counter<sup>31</sup> is widely used for detecting radiation in the range 0.7 to 3 Å, and, since it is relatively insensitive to scattered hard radiation, the background intensity is low. Its principal disadvantage is the long time needed for the counter to recover after a discharge has occurred (dead time). During this time, 200 to 300 microseconds, the counter is inactive and at moderately high intensities there are serious counting losses. A Geiger counter is not normally used for measuring intensities in excess of 1000 counts per second.

Proportional<sup>32, 33</sup> and scintillation<sup>34</sup> counters have a short dead time ( $\sim 0.2$  microseconds), so that the response to X-ray photons is linear up to extremely high count rates. In addition, the amplitude of a pulse delivered by these counters is proportional to the energy, and therefore inversely proportional to the wavelength, of the absorbed X-ray photon, so it is possible to discriminate electronically against unwanted radiations. An important advantage of the scintillation counter is its high sensitivity over the range 0.3 to 2.5 Å, but it is not used for detecting radiation softer than Ti  $K\alpha$  because the signal is then indistinguishable from detector noise.

A gas-flow proportional counter<sup>18</sup> is used with vacuum or helium-filled spectrographs for detecting soft X-radiation (3 to 11 Å). The mixture of gases, usually 90 per cent. of argon and 10 per cent. of methane, flows continuously through the tube, so that a leak-proof window is not necessary. In consequence, the window can be made extremely thin and high transmittance for long wavelengths is obtained.

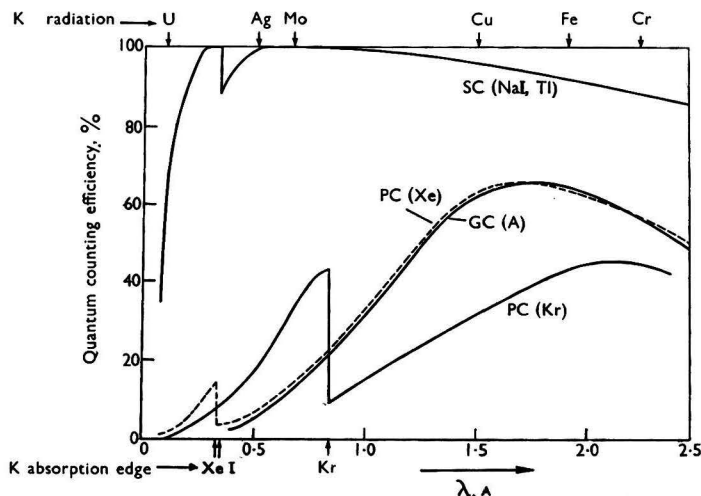

Fig. 7. Variation in calculated quantum counting efficiency with wavelength ( $\lambda$ ) for typical scintillation (SC), krypton- or xenon-filled proportional (PC) and argon-filled Geiger (GC) counters<sup>30</sup>

#### QUANTITATIVE ANALYSIS

##### SPECIMEN PREPARATION—

The specimens examined are often the actual samples received for analysis, but some specimen preparation is occasionally necessary.

The effects due to differences in the sizes of the particles must be considered when powders are examined, because the absorption of fluorescence radiation increases with grain size. Methods for avoiding particle-size problems include (i) grinding the sample, either alone<sup>35</sup> or with an added abrasive, such as silicon carbide,<sup>36,37</sup> until the effect of particle-size differences is negligible, (ii) mixing the sample with a binder and pressing into briquette form,<sup>38,39</sup> and (iii) dissolving the sample in fused borax and casting the melt as a glass disc.<sup>40</sup>

Bulk metal samples must be of a size such that they will fit the specimen holder and should present a flat surface to the primary beam. Koh and Caugherty<sup>41</sup> found that surface finish, grain size and residual stresses do not greatly affect the intensity of characteristic radiation from alloys. If metallic samples are received as millings, drillings, filings or wire, it is necessary either to use the acid solution as a specimen or to evaporate the solution to dryness and examine the powder.<sup>39</sup>

The use of solutions as specimens<sup>42,43,44,45</sup> is particularly suitable for many internal-standard and addition methods of analysis. The heating effect of the X-ray beam may result in concentration errors, owing to expansion or vaporisation of the liquid, but such errors are usually small because of the short irradiation time.

The amount of specimen used is not important provided that the area defined by the aluminium mask is completely covered and a certain critical depth of penetration by X-rays is exceeded. (In some instances, *e.g.*, the determination of silver and bromine on photographic film, the critical depth is not exceeded.) This depth is about 0.03 mm for nickel, iron and chromium,<sup>41</sup> 0.25 mm for minerals<sup>46</sup> and several millimetres for liquid specimens.

##### EXCITATION—

A spectral series will be most effectively excited by radiation that has a wavelength coincident with the absorption edge of the series. When several elements in a specimen have

to be excited, it is impracticable to use a different monochromatic radiation of the ideal wavelength for exciting each element, so it is necessary to use the primary continuous radiation. The primary characteristic radiation will make an appreciable contribution to the excitation when a strong primary line has a wavelength just shorter than the absorption edge of the series. Since the total energy emitted as primary radiation increases with the atomic number of the target material, it would be expected that radiation from a tungsten target would be more effective than that from a molybdenum target for exciting X-ray spectra. Campbell, Carl and White<sup>47</sup> have found that primary radiation from tungsten is more generally useful but, for exciting the elements from germanium (32) to yttrium (39), a molybdenum tube is preferable because of the contribution of the molybdenum characteristic spectrum.

The optimum excitation voltage depends on the absorption edge of the series to be excited. As the tube voltage increases, there is an increase in the intensity of the primary continuous spectrum and a decrease in the wavelength of the radiation having the maximum intensity (see Fig. 1). The most effective component of the continuum for exciting a spectral series is that just on the short-wavelength side of the absorption edge, so for exciting short-wavelength spectra it is evident that the tube should be operated at its maximum voltage. For fluorescence radiation of longer wavelength, a voltage setting below maximum is better, because the most effective component is now in the long-wavelength region, where an increase in tube voltage results in a small increase in intensity relative to the integrated intensity of the continuum. At higher voltages, therefore, the background intensity due to general scattering of the continuum will increase more rapidly than the intensity of the fluorescence line and the resulting decrease in the ratio of peak to background gives a lower sensitivity.<sup>3</sup> The optimum tube voltages for exciting the K spectra of iron and molybdenum are 35 and 60 kV, respectively.<sup>29</sup>

#### ABSORPTION EFFECTS—

Ideally, the intensity of a line would be independent of the matrix and would increase linearly with concentration over the range 0 to 100 per cent. It would then be possible to determine the concentration of an element in any sample by using only the pure element as a standard. Deviations from linearity are due to absorption of X-radiation, both primary and fluorescence, by the elements present in the sample.<sup>48</sup>

The absorption coefficient for X-radiation increases between absorption edges as approximately the fourth power of the atomic number,<sup>4</sup> so the composition of the specimen will influence the depth of penetration of the primary beam and therefore the number of atoms of the element being determined that will be excited. The measured fluorescence radiation is affected by specimen composition in the same way.

The second type of absorption effect depends on the relative position of characteristic lines and edges. For example, Fe  $K\alpha$  radiation ( $\lambda = 1.932 \text{ \AA}$ ) is strongly absorbed by chromium ( $\lambda_{\text{abs.}} = 2.066 \text{ \AA}$ ); Ni  $K\alpha$  radiation ( $\lambda = 1.655 \text{ \AA}$ ) is strongly absorbed by and therefore excites iron ( $\lambda_{\text{abs.}} = 1.739 \text{ \AA}$ ). Thus, if iron is to be determined in a specimen containing iron, nickel and chromium, the intensity of Fe  $K\alpha$  radiation will depend not only on the iron content but also on the amounts of nickel and chromium present.<sup>41</sup>

#### METHODS OF QUANTITATIVE ANALYSIS—

For quantitative analysis it is necessary to obtain a relationship between line intensity and concentration of the element to be determined.

The simplest method is to prepare a calibration curve showing the variation in line intensity with concentration by using chemically analysed samples. The curve will be linear only if the absorption effects described in the previous section are negligible, and any deviations from linearity may be minimised by using standards that are closely similar in composition.<sup>49</sup> This method is particularly well suited to the analysis of routine samples, in which the concentration of each element is restricted to a fairly narrow range.

In the addition technique, the intensity of the analytical line is measured before and after the addition of a known amount of the element.<sup>47</sup> The method is best suited to the determination of concentrations of less than 5 per cent. of an element, because it is necessary to assume a linear relationship between line intensity and concentration.

The internal-standard method, which has been widely used to avoid absorption problems,<sup>50,51,52</sup> involves the addition to the sample of a known amount of a reference element that will give a characteristic line close to the analytical line and is affected in the same way



by disturbances due to absorption. Standards are used to determine the variation in the ratio of the analytical and reference-line intensities with concentration, and the calibration may be used to determine the element in variable matrices. The choice of a reference element depends on the relative positions of the characteristic lines and absorption edges of the element to be determined, the reference element and the disturbing elements responsible for absorption effects.<sup>37,53</sup> Preferential absorption of a line would occur if a disturbing element had an absorption edge between the comparison lines; one line would be preferentially enhanced by a strong disturbing line between the absorption edges of the comparison elements. These circumstances must be avoided by choosing an appropriate reference element.

Matrix dilution will also avoid serious absorption effects. The samples are heavily diluted with a material having a low absorption, so that the resulting specimens have about the same absorption for X-rays. The concentration, and therefore the effect, of the disturbing elements is reduced, and although the intensity of the measured radiation is also reduced, a linear calibration graph can be obtained. Gunn<sup>54</sup> used a (1 + 1) mixture of lithium carbonate and corn starch as a diluent; the method of fusing the samples with borax and casting the melt as a glass disc has already been mentioned.<sup>40</sup>

Arithmetical correction factors have been used to overcome absorption problems.<sup>55</sup> These factors are calculated from a family of curves showing the variation of intensity with concentration of the element to be determined, each curve representing a different amount of the disturbing element. Sherman<sup>56</sup> derived a set of equations relating intensity to concentration by using parameters obtained from the examination of standards, and Noakes<sup>57</sup> has described an absolute method for the analysis of multi-component alloys.

#### APPLICATIONS

Comprehensive bibliographies of the analytical applications of X-ray fluorescence spectrometry have been published by Mack<sup>58</sup> and Liebhafsky and Winslow.<sup>59</sup> The following examples will illustrate the rapidity, versatility and precision of the technique.

The analysis of high-temperature alloys<sup>49,60</sup> and the investigation of oxidation and diffusion processes in metallic systems<sup>41</sup> have been described. Molybdenum (0.7 to 5.8 per cent.) and ruthenium (0.5 to 4.6 per cent.) in uranium have been determined with average absolute errors of 0.03 and 0.05 per cent., respectively.<sup>61</sup> Silverman, Houk and Moudy<sup>62</sup> obtained a coefficient of variation of 0.5 to 1.0 per cent. for the determination of 15 to 25 per cent. of uranium dioxide in stainless steel by using strontium as internal standard. The counting time was about 12 minutes, and large amounts of iron, chromium and nickel were without effect on the result.

Methods for the analysis of various types of mineral have been discussed by Carl and Campbell.<sup>46</sup> The determination of thorium in ores and rocks by using thallium<sup>63</sup> or selenium<sup>66</sup> as internal standard has been described, and Gulbransen<sup>64</sup> has determined barium in barite ores to within 0.5 per cent. of the result obtained by wet chemical methods. After a calibration curve has been prepared and the sample ground, a determination can be made in 3 minutes. The analysis of amphibolite rocks has been investigated by Chodos, Branco and Engel,<sup>35</sup> whose preliminary results indicate that iron, calcium, titanium, potassium, manganese, silicon, aluminium and magnesium can be determined with a relative error of 2 to 3 per cent. in 2 hours. Methods for the determination of niobium and tantalum in ores,<sup>46,51,52</sup> yttrium, thorium and the rare-earth elements in bastnaesite ore<sup>65</sup> and yttrium in rare-earth mixtures<sup>66</sup> have been reported.

Marine sediments have been analysed for barium and titanium (0.01 to 2.0 per cent.) and zinc (0.004 to 0.6 per cent.),<sup>67</sup> and Campbell, Carl and White<sup>47</sup> have compared methods of X-ray fluorescence analysis for determining germanium in coal and coal ash. By a preliminary chemical extraction of the germanium, concentrations above 0.001 per cent. could be determined to within 10 per cent. of the amount present. Clark and Terford<sup>68</sup> have found that X-ray analysis is far more reliable than chemical analysis for determining 1 to 20 per cent. of iron in dust samples. I have used a Geiger-counter spectrograph for determining strontium, as parts per million and parts per ten thousand, in samples of sodium chloride and limestone, respectively. MacNevin and Hakkila<sup>69</sup> have described a method for the determination of palladium, platinum, rhodium and iridium, in which filter-paper impregnated with a solution of the elements is used as a specimen.

Other applications that have been described include the determination of lead<sup>42,70</sup> and bromine<sup>42</sup> in petrol, bromine in liquid hydrocarbons,<sup>50</sup> uranium in aqueous solutions,<sup>43,71</sup>

barium, calcium and zinc in lubricating oils,<sup>44</sup> vanadium and nickel in residual fuels and charging stocks<sup>72</sup> and potassium in potash concentrates and tailings.<sup>73</sup>

I have found that the X-ray technique greatly facilitates the routine analysis of a wide variety of catalysts, the analysis time often being a matter of minutes. Absorption effects have been avoided by matrix dilution with borax. Dyroff and Skiba<sup>74</sup> have reported the determination of iron, nickel and vanadium on cracking catalysts in an analysis time of 15 minutes, and Gunn<sup>75</sup> has determined platinum (0.05 to 1 per cent.) on re-forming catalyst with a standard deviation of  $\pm 0.006$  per cent. of platinum at the 0.6-per cent. level.

The method has been used for the measurement of the plating thickness of metals,<sup>76</sup> and Rhodin<sup>77</sup> analysed thin ( $\sim 100$  Å) films of iron, nickel, chromium and stainless steels prepared on a Mylar support by evaporation *in vacuo*.

#### FUTURE DEVELOPMENTS

Major developments in instrumentation to extend the range of elements that can be determined to those below sodium (11) do not appear to be imminent. Improvements in X-ray tubes and detectors will increase the rapidity and precision of analyses, and automatic instruments, which are used in the U.S.A. for process control, are now being developed in Europe. It seems certain that applications of the technique to routine and non-routine analytical problems will be extended and that X-ray fluorescence spectrometry will continue to grow in popularity and importance.

I thank Mr. H. N. Wilson, Dr. J. M. Skinner and Mr. A. E. Heron for their interest and advice during the preparation of this paper.

#### REFERENCES

1. Ulrey, C. T., *Phys. Rev.*, 1918, **11**, 401.
2. Richtmyer, F. K., Kennard, E. H., and Lauritsen, T., "Introduction to Modern Physics," Fifth Edition, McGraw-Hill Book Co. Inc., New York, 1955, p. 371.
3. Parrish, W., *Philips Tech. Rev.*, 1955/1956, **17**, 269.
4. Compton, A. H., and Allison, S. K., "X-rays in Theory and Experiment," Second Edition, D. Van Nostrand Co. Inc., New York, 1935.
5. Barkla, C. G., and Sadler, C. A., *Phil. Mag.*, 1908, **16**, 550.
6. Friedrich, W., Knipping, P., and Laue, M., *Ber. bayer. Akad. Wiss.*, 1912, 303.
7. Bragg, W. L., *Proc. Camb. Phil. Soc.*, 1913, **17**, 43.
8. Moseley, H. G. J., *Phil. Mag.*, 1913, **26**, 1024; 1914, **27**, 703.
9. Hadding, A., *Z. anorg. Chem.*, 1922, **122**, 195.
10. Coster, D., and von Hevesy, G., *Nature*, 1923, **111**, 182.
11. Stintzing, H., *Z. phys. Chem.*, 1924, **108**, 51.
12. Glocker, R., and Frohnmayer, W., *Ann. Phys.*, 1925, **76**, 369.
13. Eddy, C. E., and Laby, T. H., *Proc. Roy. Soc.*, 1930, **127**, 20.
14. Calvert, J. T., *Trans. Faraday Soc.*, 1930, **26**, 509.
15. von Hevesy, G., "Chemical Analysis by X-rays and its Applications," McGraw-Hill Book Co. Inc., New York, 1932.
16. Glocker, R., and Schreiber, H., *Ann. Phys.*, 1928, **85**, 1089.
17. von Hamos, L., *Nature*, 1934, **134**, 181.
18. Hendee, C. F., Fine, S., and Brown, W. B., *Rev. Sci. Instrum.*, 1956, **27**, 531.
19. Birks, L. S., and Brooks, E. J., *Anal. Chem.*, 1955, **27**, 437.
20. Brissey, R. M., *Ibid.*, 1952, **24**, 1034.
21. Birks, L. S., Brooks, E. J., and Friedman, H., *Ibid.*, 1953, **25**, 692.
22. Powers, M. C., "X-ray Fluorescent Spectrometer Conversion Tables," Philips Electronics Inc., Mt. Vernon, New York, 1957.
23. Parrish, W., *Philips Tech. Rev.*, 1955/1956, **17**, 206.
24. Campbell, W. J., Leon, M., and Thatcher, J., "Proceedings of the 6th Annual Conference on Industrial Applications of X-ray Analysis," Denver Research Institute, Denver, Colorado, 1957, p. 193.
25. Korff, S. A., "Electron and Nuclear Counters," D. Van Nostrand Co. Inc., New York, 1946.
26. Wilkinson, D. H., "Ionisation Chambers and Counters," Cambridge University Press, 1950.
27. Parrish, W., and Kohler, T. R., *Rev. Sci. Instrum.*, 1956, **27**, 795.
28. Dowling, P. H., Hendee, C. F., Kohler, T. R., and Parrish, W., *Philips Tech. Rev.*, 1956/1957, **18**, 262.
29. Friedman, H., Birks, L. S., and Brooks, E. J., *Special Technical Publication No. 157*, American Society for Testing Materials, 1953, p. 3.
30. Taylor, J., and Parrish, W., *Rev. Sci. Instrum.*, 1955, **26**, 367.
31. Friedman, H., *Proc. Inst. Radio Engrs.*, 1949, **37**, 791.
32. Hendee, C. F., and Fine, S., *Phys. Rev.*, 1954, **95**, 281.
33. Bessen, I. I., "Proceedings of the 6th Annual Conference on Industrial Applications of X-ray Analysis," Denver Research Institute, Denver, Colorado, 1957, p. 455.

34. Birks, J. B., "Scintillation Counters," McGraw-Hill Book Co. Inc., New York, 1953.
35. Chodos, A. A., Branco, J. J. R., and Engel, C. G., "Proceedings of the 6th Annual Conference on Industrial Applications of X-ray Analysis," Denver Research Institute, Denver, Colorado, 1957, p. 315.
36. King, A. G., and Dunton, P., *Science*, 1955, **122**, 72.
37. Adler, I., and Axelrod, J. M., *Spectrochim. Acta*, 1955, **7**, 91.
38. ———, ———, *Anal. Chem.*, 1954, **26**, 931.
39. Davis, C. M., and Clark, G. R., "Proceedings of the 6th Annual Conference on Industrial Applications of X-ray Analysis," Denver Research Institute, Denver, Colorado, 1957, p. 351.
40. Claisse, F., *Norelco Reporter*, 1957, **3**, 1.
41. Koh, P. K., and Caugherty, B., *J. Appl. Phys.*, 1952, **23**, 427.
42. Birks, L. S., Brooks, E. J., Friedman, H., and Roe, R. M., *Anal. Chem.*, 1950, **22**, 1258.
43. Birks, L. S., and Brooks, E. J., *Ibid.*, 1951, **23**, 707.
44. Davis, E. N., and van Nordstrand, R. A., *Ibid.*, 1954, **26**, 973.
45. Pish, G., and Huffman, A. A., *Ibid.*, 1955, **27**, 1875.
46. Carl, H. F., and Campbell, W. J., *Special Technical Publication No. 157*, American Society for Testing Materials, 1953, p. 63.
47. Campbell, W. J., Carl, H. F., and White, C. E., *Anal. Chem.*, 1957, **29**, 1009.
48. Friedman, H., and Birks, L. S., *Rev. Sci. Instrum.*, 1948, **19**, 323.
49. Brissey, R. M., Liebhafsky, H. A., and Pfeiffer, H. G., *Special Technical Publication No. 157*, American Society for Testing Materials, 1953, p. 43.
50. Kokotailo, G. T., and Damon, G. F., *Anal. Chem.*, 1953, **25**, 1185.
51. Campbell, W. J., and Carl, H. F., *Ibid.*, 1954, **26**, 800.
52. Mortimore, D. M., Romans, P. A., and Tews, J. L., *Appl. Spectroscopy*, 1954, **8**, 24.
53. Cope, J. H., *Norelco Reporter*, 1956, **3**, 41.
54. Gunn, E. L., *Anal. Chem.*, 1957, **29**, 184.
55. Mitchell, B. J., "Proceedings of the 6th Annual Conference on Industrial Applications of X-ray Analysis," Denver Research Institute, Denver, Colorado, 1957, p. 253.
56. Sherman, J., *Special Technical Publication No. 157*, American Society for Testing Materials, 1953, p. 27.
57. Noakes, G. E., *Ibid.*, p. 57.
58. Mack, M., *Norelco Reporter*, 1956, **3**, 37.
59. Liebhafsky, H. A., and Winslow, E. H., *Anal. Chem.*, 1958, **30**, 580.
60. Brissey, R. M., *Ibid.*, 1953, **25**, 190.
61. Flikkema, D. S., and Schablaske, R. V., "Proceedings of the 6th Annual Conference on Industrial Applications of X-ray Analysis," Denver Research Institute, Denver, Colorado, 1957, p. 387.
62. Silverman, L., Houk, W. W., and Moudy, L., *Anal. Chem.*, 1957, **29**, 1762.
63. Adler, I., and Axelrod, J. M., *Ibid.*, 1955, **27**, 1002.
64. Gulbrandsen, L. B., *Ibid.*, 1955, **27**, 1181.
65. Lytle, F. W., Botsford, J. I., and Heller, H. A., "Proceedings of the 6th Annual Conference on Industrial Applications of X-ray Analysis," Denver Research Institute, Denver, Colorado, 1957, p. 367.
66. Heidel, R. H., and Fassel, V. A., *Anal. Chem.*, 1958, **30**, 176.
67. Lewis, G. J., jun., and Goldberg, E. D., *Ibid.*, 1956, **28**, 1282.
68. Clark, G. L., and Terford, H. C., *Ibid.*, 1954, **26**, 1416.
69. MacNevin, W. M., and Hakkila, E. A., *Ibid.*, 1957, **29**, 1019.
70. Lamb, F. W., Niebylski, L. M., and Kiefer, E. W., *Ibid.*, 1955, **27**, 129.
71. Kehl, W. L., and Russell, R. G., *Ibid.*, 1956, **28**, 1350.
72. Davis, E. N., and Hoeck, B. C., *Ibid.*, 1955, **27**, 1880.
73. Gulbrandsen, L. B., *Ibid.*, 1956, **28**, 1632.
74. Dyroff, G. V., and Skiba, P., *Ibid.*, 1954, **26**, 1774.
75. Gunn, E. L., *Ibid.*, 1956, **28**, 1433.
76. Beeghly, H. F., *J. Electrochem. Soc.*, 1950, **97**, 152.
77. Rhodin, T. N., *Anal. Chem.*, 1955, **27**, 1857.

Received February 2nd, 1959

## Analytical Methods Committee

REPORT PREPARED BY THE VITAMIN-E PANEL

### The Determination of Tocopherols in Oils, Foods and Feeding Stuffs

THE Analytical Methods Committee has received the following report from its Vitamin-E Panel. The Report has been approved by the Analytical Methods Committee and its publication has been authorised by the Council.

#### REPORT

In March, 1953, the Sub-Committee on Vitamin Estimation of the Analytical Methods Committee was asked by the Biological Methods Group to report on the need to promulgate standard methods of analysis for the tocopherols.

A Vitamin-E Advisory Panel was accordingly appointed "to survey the methods already proposed for the estimation of vitamin E and to report to the Sub-Committee on the work required to establish a standard method or methods." The Panel consisted of A. L. Bacharach (Chairman), F. Brown, T. Moore, A. R. Moss, H. N. Ridyard and S. A. Price (Hon. Secretary). This Panel recommended unanimously, after one meeting, that approval for a method or methods was desirable. Its report was accepted in 1953 by the Analytical Methods Committee, which forthwith appointed a working Vitamin-E Panel to follow the lines indicated in the Advisory Panel's report. The membership of the working Panel was A. L. Bacharach (Chairman), J. Green (Hon. Secretary), P. W. Russell Eggitt, A. R. Moss, H. N. Ridyard, C. A. Shacklady, P. Stross, G. Walley, R. J. Ward and E. C. Wood. On her appointment as Secretary to the Analytical Methods Committee early in 1955, Dr. C. H. Tinker took over the secretaryship of the Vitamin-E Panel, but Dr. J. Green agreed to continue as Hon. Technical Secretary to the Panel, and in this capacity has earned both the Panel's and Dr. Tinker's gratitude for his continuous and valuable help. At a later stage of the Panel's work, Dr. V. H. Booth was co-opted as a member of the Panel.

The Panel is most grateful to a number of manufacturers and members of their scientific staffs for supplying various concentrates, oils and solutions essential to its work, namely, J. Bibby and Sons Ltd., British Drug Houses Ltd., Roche Products Ltd. and Vitamins Ltd. Especial thanks are also afforded to Dr. Philip L. Harris of Distillation Products Inc., Rochester, New York, U.S.A., for generous gifts of purified tocopherols.

#### INTRODUCTION—

The determination of vitamin-E activity, when it is not carried out directly by biological assay, involves two logically connected but methodologically different processes. The first involves chemical analysis, the second computation only, but computation based on previous biological assays. The vitamin-E activity of any material can be determined if two conditions are satisfied. First, there must be available means of determining with sufficient accuracy the amounts of the different tocopherols present in the material. Secondly, weighting factors must be available for application to each separately determined tocopherol, so that the total amount present can then be appropriately expressed in terms of the biological activity of one of them—preferably of  $\alpha$ -tocopherol, because it is the most widely distributed, the best known and probably the most biologically active for most species; moreover, the International Standard of vitamin E is DL- $\alpha$ -tocopheryl acetate.

Of this two-stage process for determining vitamin-E activity, only the first fell within the scope of the Panel's activities, for only the first comes into the category of an analytical determination. The second stage is, moreover, for vitamin-E determination, fraught with peculiar and complex difficulties, to which brief reference is made below. Nevertheless the solving in advance of the purely analytical problems besetting tocopherol determination might be an advantage, however contrary to the traditional pattern of events in the history of vitamin determination.

## THE OBJECTIVE—

The words used in the Report of the Vitamin-B<sub>12</sub> Panel (*Analyst*, 1956, 81, 132) seem to us to apply, *mutatis mutandis*, to the problem of vitamin-E analysis. They were "When the test substance has biological activity, it is not the function of the Panel to supplement its analytical recommendations by interpretations of that activity or to institute relevant researches in clinical medicine or animal nutrition. The Panel . . . has accordingly restricted its deliberations and experiments to the establishment for the determination of vitamin B<sub>12</sub> of an analytical method that . . . is least affected by the known vitamin B<sub>12</sub>-like substances that may co-exist with the vitamin B<sub>12</sub>."

The Vitamin-E Panel has had to solve a more difficult analytical problem. When it began its work, four tocopherols had been discovered; since then three others have been isolated from natural sources. The seven tocopherols have different biological activities as well as different chemical properties; moreover, these activities are not necessarily the same in different biological tests. Indeed, because of the varied distribution of the tocopherols in natural products, a considerable proportion of a foodstuff's vitamin-E activity might be contributed by a tocopherol of low biological potency.

The Panel could not escape the conclusion that its terms of reference implicitly ask for a method capable of measuring with reasonable precision and accuracy all seven tocopherols. As the unexpected dimensions of this task became apparent to the Panel, its members were to some degree consoled by realizing that they were undertaking what is almost certainly the first collaborative study of two-dimensional paper chromatography as a procedure in quantitative analytical chemistry.

The tocopherols have been regarded as methylated derivatives of a parent compound, for which the name tocol, originally put forward by Karrer and Fritzsche,<sup>1</sup> has been accepted. Its structure and that of the derivatives are given by the general formula—

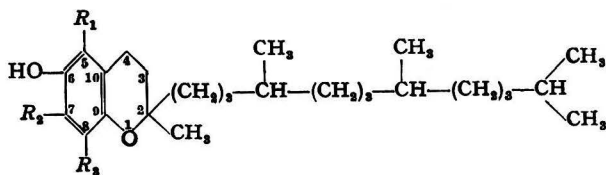

Tocol:  $R_1 = R_2 = R_3 = H$ .

TABLE I  
STRUCTURAL RELATIONSHIP OF THE TOCOPHEROLS

Tocopherol	Chemical name	Methyl groups
$\alpha$	5:7:8-Trimethyltol	$R_1, R_2$ and $R_3$
$\beta$	5:8-Dimethyltol	$R_1$ and $R_3$
$\gamma$	7:8-Dimethyltol	$R_2$ and $R_3$
$\eta$	7-Methyltol	$R_2$
$\delta$	8-Methyltol	$R_3$

For a note on the structures of  $\epsilon$ - and  $\zeta$ -tocopherol, consult text.

Table I shows the structures of those individual tocopherols for which they have been ascertained. There are now serious reasons<sup>2</sup> for doubting the identity of  $\epsilon$ -tocopherol with 5-methyltol and of  $\zeta$ -tocopherol with 5:7-dimethyltol, structures that had previously been allotted to them; no such structures have therefore been assigned in Table I. In this, the alphabetical order of the Greek letters merely denotes the order in time of first identifying the different tocopherols and gives no key to structure. It is possible that further work on the structures of  $\epsilon$ - and  $\zeta$ -tocopherol may lead to some modification of the general statements about the relationship between tocol and the tocopherols.

While trying to develop a method that could be used for determining all seven tocopherols in whatever amounts and proportions they might be present, whether in a single raw material or a complex mixture, such as a compounded animal feeding stuff, the Panel bore continuously in mind that the analytical problem might frequently be a less complex one and that the method could be correspondingly simplified in certain circumstances.

## THE TOOLS

Several review articles have appeared on the analysis of vitamin E. The most recent of them is that by Lehman,<sup>3</sup> who has surveyed all the "classical" methods available for the determination of vitamin E. Methods of paper chromatography, which have formed the basis of the Panel's work, are mentioned in this article, but are not given particularly favourable or even adequate consideration. Moreover, three tocopherols are now known that were not discussed by Lehman, and their existence makes the older methods inapplicable. It is therefore necessary to deal briefly with the present status of methods for vitamin-E determination, if only to put paper chromatography in proper perspective among them.

All proposed procedures for vitamin-E analysis include three main stages—

- (1) extraction of the lipid containing the vitamin E;
- (2) removal of interfering substances; and
- (3) determination of the tocopherols.

Stages (1) or (2) may be omitted whenever the tocopherol is already at a high enough concentration to permit stage (3) to be carried out without appreciable error. In addition, a further stage (4) must be added if it is necessary to determine individual tocopherols, as the Panel believes that it usually is.

## EXTRACTION—

The materials investigated by the Panel were primarily vegetable oils. The methods described below should be applicable to the fat-soluble extracts of other biological materials, but detailed methods for making the extracts have not been investigated by the Panel in concert. It was the opinion of the Panel that the tocopherols were sufficiently stable to involve no especial hazards or difficulties when one of the several normal methods of fat extraction is used. Several such methods<sup>4,5,6</sup> applied particularly to tocopherol determination have been described in the literature and are, in the opinion of individual members of the Panel, satisfactory.

## REMOVAL OF INTERFERING SUBSTANCES—

This stage includes a number of steps that may be used singly or together. In general, two types of interfering substances exist in natural products: those that have reducing power and therefore interfere with the final determination by giving falsely high results; and those that inhibit or enhance the colour produced in the final determination, although having no reducing power.

(a) *Saponification* of the lipid fraction usually removes all substances of the second type and some of the first. It also serves to concentrate the tocopherol fraction more than is possible by any other practicable single step. Saponification is the most effective first purification step, whatever means of final determination is used; but in the past saponification has often been avoided because of the real danger to which it may subject the alkali-sensitive tocopherols. Many methods of saponification described in the literature do not give satisfactory recovery of vitamin E. However, the Panel is satisfied that this step can be carried out with nearly quantitative recovery of tocopherols, providing suitable precautions are taken.

(b) *Molecular distillation* has been used by some who have wished to avoid saponification. In this method,<sup>7</sup> the tocopherols are concentrated in a small pot-type non-cyclic molecular still. The distillate contains the vitamin E, freed from many interfering substances, but carotenoids and some other reducing compounds collect in the fraction that contains the tocopherols.

(c) *Hydrogenation* has been used as a purification step, usually in conjunction with molecular distillation.<sup>4,8</sup> The distilled sample is reduced with hydrogen over a palladium catalyst. Carotenoids and some other substances are reduced and do not thereafter interfere in the analysis, whereas tocopherols are not altered. Methods (b) and (c) do not appear suitable as stages in a "standard" method.

(d) *Sulphuric acid procedure.* Non-tocopherol reducing materials have sometimes been removed by shaking a solution of the vitamin-E concentrate or oil in light petroleum with 85 per cent. v/v sulphuric acid.<sup>9</sup> There are doubts, however, as to the quantitative nature of this

method. It may produce artefacts giving falsely high results in the final colorimetric determination.<sup>10</sup>

(e) *Column chromatography* has also been used. Most workers have adopted the method of Emmerie and Engel<sup>11</sup> as modified by Kjölhede,<sup>12</sup> passing the vitamin-E solution through a column of activated floridin earth, previously treated with stannous chloride. This type of chromatography, especially as recently improved, removes carotenoids, vitamin A and some other reducing substances. Lehman has stated in his review<sup>3</sup> that "there is serious risk of loss in this step." This view may have arisen, mistakenly, from the work of Kaunitz and Beaver,<sup>13</sup> who concluded that the presence of fat in extracts *increased* the adsorption of tocopherols on floridin and hence that some tocopherol was lost during filtration. This would hardly seem to be in keeping with the known effects of fats on adsorptive properties, and it is likely that the results were influenced by the marked depressive effect of fats in the ferric chloride - dipyriddy determination, also investigated by the same workers, whose procedure did not include saponification. The Panel has found that floridin earth chromatography can be performed without detectable loss, providing that suitable precautions are taken in the preparation of the column and elution of the tocopherols (consult Appendix II).

(f) *Paper chromatography* may also play its part in removing interfering matter, but its main role is to separate the different tocopherols. It is dealt with on p. 360.

#### DETERMINATION OF THE TOCOPHEROLS—

It seems generally agreed that the Emmerie - Engel method<sup>11</sup> is the most suitable. The tocopherol is treated with a mixture of ferric chloride and 2:2'-dipyriddy in ethanolic solution. Tocopherols reduce the iron to the ferrous state; it then combines with the dipyriddy to form a red colour, which is measured in a photoelectric colorimeter or spectrophotometer. Under standardised conditions, the method gives a high degree of accuracy and precision with pure tocopherols. However, individual tocopherols react at somewhat different rates and give somewhat different intensities of colour.<sup>14</sup>  $\delta$ -Tocopherol, in particular, reacts differently from the others. Therefore earlier methods have included highly standardised procedures for the assay of substances containing more than one tocopherol; indeed, procedures recommended for the final determination are almost as numerous as the workers who have investigated them.

#### DETERMINATION OF INDIVIDUAL TOCOPHEROLS—

Before 1953, only four tocopherols had been discovered in natural sources. Even so, the determination of those four compounds individually was difficult by "classical" methods. Three general procedures were available.

(i) Differentiation of the tocopherols by making use of their different rates of oxidation under certain conditions.<sup>15</sup> This method does not appear to be accurate, and it has been little used.

(ii) The "nitroso" method of Quaife<sup>16</sup> has been more widely used for the determination of "non- $\alpha$ -tocopherols." It depends on the fact that  $\beta$ -,  $\gamma$ - and  $\delta$ -tocopherol react with nitrous acid to give yellow nitroso-derivatives. These can be determined together by colorimetric methods, and the  $\alpha$ -tocopherol is then found by subtraction from the total tocopherols as measured by the Emmerie - Engel procedure. The nitroso method, although simple, suffers from the disadvantage that the important  $\alpha$ -tocopherol is measured by difference. Since the three nitroso-derivatives have different extinctions, prior knowledge of the test sample's composition is necessary to permit use of a sufficiently accurate mean extinction for the subtraction needed to give a value for  $\alpha$ -tocopherol. This introduces additional error. Although the three nitroso-derivatives can be separated by column chromatography,  $\beta$ -,  $\gamma$ - and  $\delta$ -tocopherol are not distinguished from each other by the method as normally used.

Recent work<sup>17,18</sup> has shown that the nitroso method itself can be troublesome, owing to the reaction of nitrous acid with the ethanol solvent. Moreover, the nitroso procedure can be used only on samples of fairly high potency.

(iii) *Dianisidine coupling method.* The  $\gamma$ - and  $\delta$ -tocopherol couple with diazotised *o*-dianisidine in alkaline solution to give dyes that can be extracted and determined colorimetrically.<sup>19</sup> If  $\beta$ -tocopherol be assumed absent,  $\alpha$ -tocopherol can be found by a subtraction procedure, but any  $\beta$ -tocopherol present will be measured with the  $\alpha$ -tocopherol determination. Impurities inhibit the coupling reaction, which is also affected by the presence of much  $\alpha$ -tocopherol. Recent work<sup>20</sup> has shown that the coupling of  $\delta$ -tocopherol may be incomplete.

In an unknown sample, recovery experiments must be carried out to determine the extent of inhibition (and presumably also of non-reaction).

The discoveries of  $\epsilon$ -,  $\zeta$ - and  $\eta$ -tocopherol render the classical methods obsolete, except in certain clearly defined circumstances. The  $\epsilon$ - and  $\eta$ -tocopherol both give the nitroso reaction, but  $\zeta$ -tocopherol does not, and it will therefore be measured with  $\alpha$ -tocopherol by this method. Because  $\eta$ -tocopherol gives the dianisidine coupling reaction, its presence must complicate  $\gamma$ - and  $\delta$ -tocopherol determinations, and the non-coupling of  $\epsilon$ - and  $\zeta$ -tocopherol destroys the validity of dianisidine methods for even approximately measuring  $\alpha$ -tocopherol.

#### PAPER CHROMATOGRAPHY—

Recent methods<sup>21,22,23</sup> for chromatographic separation of tocopherols on paper have several advantages over the classical methods of vitamin-E determination and deal successfully with most of the problems raised by the discovery of the new tocopherols. The advantages are that—

(a) the known tocopherols are separated into five "spots" or zones on the paper. The  $\alpha$ -,  $\delta$ - and  $\zeta$ -tocopherol occur as individual spots and can be determined individually. The  $\beta$ - and  $\gamma$ -tocopherol occur together as one spot and  $\epsilon$ - and  $\eta$ -tocopherol together as another. Dianisidine coupling carried out directly on the paper chromatogram identifies  $\gamma$ - and  $\eta$ -tocopherol;

(b) the important  $\alpha$ -tocopherol can be determined directly, without the use of any subtraction procedure;

(c) the isolation of the individual tocopherols and knowledge about their reactions with ferric chloride render unnecessary any compromise over reaction conditions for the colorimetric assay. There is also no necessity to assume an arbitrary conversion factor, since, with certain exceptions discussed on p. 365, the conversion factor for each tocopherol can be used independently;

(d) because individual tocopherols are separated on the chromatogram, some of the older purification techniques become unnecessary. Only such purification is carried out as is essential for subsequent successful chromatographic separation. This always involves saponification of low-potency oils and may also require chromatography on floridin earth for removal of interfering substances. Once the separation is made, however, the analyst can, by running authentic tocopherols on the paper as tracers in a control test, be assured that he is measuring a tocopherol and nothing else;

(e) the method is suitable for micro-determinations below the range of the older methods.

#### METHOD

The Panel has examined in detail through collaborative tests the various steps involved in the determination of the tocopherols. Analysis of samples likely to present themselves for tocopherol determinations may involve all, or most of, the seven stages enumerated below with their purposes.

(a) Solvent extraction of a representative sample with a lipid solvent, for quantitative separation of all tocopherols present, along with other fatty material.

(b) Saponification of the lipid extract and separation from it of the unsaponifiable matter. The method is based on that of Totic and Moore.<sup>24</sup>

(c) Separation of most of the steroid material by freezing from solution in methanol.

(d) Column chromatography on floridin earth to remove carotenoids and residual steroids.<sup>25</sup> (See Appendix II.)

(e) Two-dimensional paper chromatography,<sup>23</sup> to separate the tocopherols into five zones, and individual elution.

(f) Treatment of the eluates with the Emmerie - Engel reagent and reading of the extinctions at 520  $m\mu$  in a suitable instrument.<sup>6</sup> The Panel considers the presently described modification of the Emmerie - Engel method to be an advance on any previous technique. It is rapid and well suited for determining tocopherols in micro amounts. The concentration of reagents is such that all the tocopherols give maximum or almost maximum colour in the short time (2 minutes) before measurement is made.



(g) Calculation of tocopherol equivalents from extinctions by using the established factor for each tocopherol.

The seven stages enumerated above may not all be necessary. The most obvious omission is of stage (a) when the sample to be examined is a clean oil or fat. Stage (c) is only necessary for materials of low potency. Stage (d) can be omitted during the analysis of samples containing more than 5 to 10 mg of tocopherols per g of oil, and possibly in certain other circumstances not easy to define or forecast.

The results of a typical collaborative test on two vegetable oils and a chick meal are given in Appendix III.

#### REAGENTS—

*Pyrogallol solution, 5 per cent. w/v in ethanol*—Prepare this solution daily for each assay.

*Potassium hydroxide solution*—Dissolve 160 g of potassium hydroxide, analytical-reagent grade, in 100 ml of distilled water.

*Diethyl ether*—Analytical-reagent grade or anaesthetic B.P. (For note on peroxide content, see Appendix I, 1.)

*Ethanol, absolute*—Purify by distillation in an all-glass apparatus over potassium permanganate and potassium hydroxide (1 and 2 g, respectively, per litre of ethanol).

*Ethanol, diluted*—Add 75 parts by volume of absolute ethanol to 25 parts by volume of distilled water.

*Floridin earth XS*—Specially selected for use in tocopherol determination.\*

*Stannous chloride*—Analytical-reagent grade.

*Hydrochloric acid, sp. gr. 1.18*—Analytical-reagent grade.

*Benzene*—Analytical-reagent grade.

*cycloHexane*—Analytical-reagent grade.

*Zinc oxide*—Analytical-reagent grade.

*Ammonium hydroxide, sp. gr. 0.880*—Analytical-reagent grade.

*Ammonium carbonate*—Analytical-reagent grade.

*Sodium fluorescein*—A 0.1 per cent. solution in water.

*Papers*—Whatman No. 1 grade "for chromatography," in sheets 51.2 cm × 46.4 cm (22½ inches × 18½ inches). (For notes on No. 4 grade paper, see Appendix I, 4.)

*Liquid paraffin solution*—A 3 per cent. w/v solution of liquid paraffin B.P. in light petroleum, boiling range 60° to 80° C.

*Ferric chloride solution*—Ferric chloride hexahydrate, analytical-reagent grade, 0.2 per cent. w/v in ethanol. Being extremely liable to photochemical reduction, this solution must be prepared directly in the amber bottle in which it is to be stored. The bottle should not be exposed even to moderate daylight and is best masked by a covering of black paper or black paint.

*Dipyridyl solution*—A 0.5 per cent. w/v solution of 2:2'-dipyridyl, analytical-reagent grade, in ethanol.

#### ANALYTICAL PROCEDURE—

##### 1. Saponification of the oil—

Weigh accurately about 1 g of the oil into a round-bottomed flask (50 to 150 ml is a suitable size). Add 4 ml of the pyrogallol solution, and heat in a water bath, using a cold-finger condenser or a small reflux condenser fitted with a ground-glass joint. When the mixture boils, remove the condenser, and add 1 ml of the potassium hydroxide solution. Replace the condenser, immerse the flask in the boiling-water bath, and heat under vigorous reflux for 3 minutes, with occasional shaking.

Remove the flask from the water bath, cool the contents, and add 20 ml of distilled water. Extract the unsaponifiable matter with diethyl ether three times, using about 25 ml for each extraction. If the phases fail to separate quickly and sharply, add .1 or 2 ml of ethanol. If emulsions persist, consult Appendix II. Wash the combined ether extracts with 20-ml portions of distilled water until neutral to phenolphthalein, avoiding vigorous shaking at first. Three or four washes are usually necessary. Transfer the ether solution to a round-bottomed flask, and remove the ether by evaporation in a current of nitrogen, or under reduced pressure, while warming the solution on the water bath. Dry the residue, if

\* "Floridin earth XS for the determination of vitamin E" (obtainable from the British Drug Houses Ltd.).

necessary, by adding a little absolute ethanol and benzene and re-evaporating. Do not dry the solution with magnesium sulphate or sodium sulphate, because these chemicals may contain traces of iron. Dissolve the dry residue either in 5 ml of benzene for step 3 or in methanol (see Appendix I, 2) for step 2.

#### 2. Removal of sterols—

It is rarely necessary to remove sterols before chromatography. However, with extracts of certain materials, poor separation on paper may be due to the presence of sterols. Directions for removing these are given in Appendix I, 2.

#### 3. Floridin earth separation—

(a) *Apparatus*—Columns are prepared in the usual type of chromatographic adsorption tube, 1.2 to 1.4 cm internal diameter and about 16 to 20 cm long. Tubes must not have smaller dimensions than those indicated.

(b) *Preparation of column*—Mix 5 g of floridin earth and 0.5 g of stannous chloride with 20 ml of hydrochloric acid, and bring to the boil. With rapid stirring, pour the slurry into a chromatographic tube in one continuous operation, so that the earth settles with an even gradation. After the liquid has passed through, wash the column successively with five portions, each of 5 ml, of ethanol, and then with five portions, each of 5 ml, of benzene.

(c) *Column chromatography*—Pass the benzene solution from step 1 (or step 2) through the prepared floridin earth column. Elute the column with seven portions, each of 5 ml, of benzene, the complete elution taking not less than 45 minutes. Nitrogen under pressure or gentle suction may be used to hasten both the preparation of the columns and the chromatography, provided the latter process takes not less than 45 minutes. If total reducing substances are to be determined, an aliquot may be taken at this stage. It is safe to store the benzene solution overnight in a refrigerator.

#### 4. Paper chromatography—

(a) *Preparation of zinc-ammine solution*—Dissolve 16 g of zinc oxide and 25 g of ammonium carbonate in a mixture of 150 ml of ammonium hydroxide and 600 ml of distilled water. Add 5 ml of sodium fluorescein solution. This zinc-ammine solution is indefinitely stable in a stoppered bottle.

(b) *Preparation of zinc carbonate impregnated paper*—Because solvents move faster along the machine direction of filter-paper than across it, all the papers should be similarly orientated. The procedure described below ensures the most evenly coated papers with the minimum handling of the working portion; the position of the written date gives a clue to the machine direction of the paper. Cut the large sheets of paper into four equal parts, as indicated in Fig. 1. Pour the zinc-ammine solution into a large dish. Immerse each sheet separately in the solution to within about 5 cm of one short edge, and hang all the sheets to drain at room temperature for about an hour. The dry margin allows the use of clips for supporting the papers. Dry the papers, hanging vertically, at 95° to 100° C for 3 hours in an oven with or without forced air circulation. Remove the dried papers, cut a 20-cm square from the coated portion of each sheet, and write the date close to the edge GH. The prepared papers may be stored for a few weeks in a thoroughly dry place, but they are soon spoiled by humidity.

Rule each paper lightly in pencil, as shown by the thin lines in Fig. 1. Punch holes in the corners, if necessary, for use on a frame.

(c) *Apparatus*—Chromatography in both dimensions is done by the ascending-solvent method, and should be carried out in a glass tank large enough to hold the 20-cm × 20-cm papers in a vertical position. It is advisable to use a separate tank for each dimension. Alternatively, both runs may be carried out in the same tank; the necessary change of solvent must then be made before running the second dimension. The inside walls of each tank must be lined with a sheet of filter-paper, saturated with the mobile phase. The tanks must have gas-tight lids, and they should be shielded from strong light.

When less than four papers are run together, and provided that the chromatograms are to be examined later under ultra-violet light (method (i) of section (f) below), they may be supported in each tank by glass rods, arranged so that the papers hang evenly, with their edges dipping into the solvent. It is, however, more convenient to use some sort of two-dimensional chromatographic frame for carrying the papers, and this is recommended. If spot location is to be by spraying (method (ii) of section (f) below), or, if four or more papers

are to be run together, such a frame is essential. Its use enables the papers to be manipulated easily and simultaneously during the various stages of the chromatographic separation, and ensures that the chromatograms are uniform and reproducible. Such frames have been described,<sup>26,27</sup> and are suitably made of aluminium. Commercial frames are also available (see Appendix I, 5).

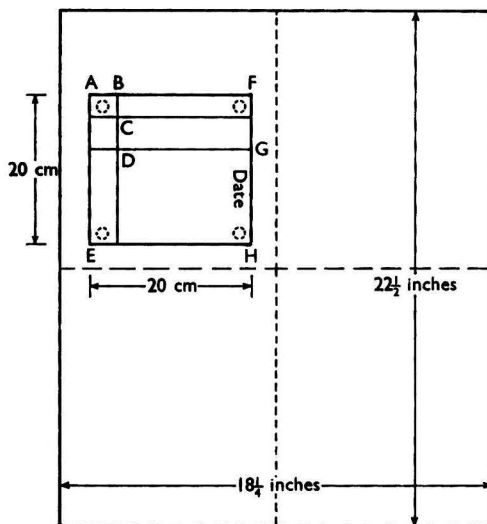

Fig. 1. Dimensions of zinc carbonate impregnated paper. Care should be taken to preserve the machine direction of the paper (as indicated on the package).  $AB = BC = 2$  cm.  $CD = 3$  cm. The letters need not be copied; they are inserted here only for explanatory purposes

(d) *First-dimension chromatography*—Evaporate the solution from step 3 (c) to dryness under reduced pressure or in nitrogen. Dissolve the residue in 0.5 to 3 ml of benzene in a stoppered flask, to give a solution containing 0.5 to 2.0 mg of tocopherol per ml, if possible. (Polar solvents must not be used for preparing this solution.) Set the tocopherol solution, by means of discrete additions of 10 to 20  $\mu$ l, as a narrow band across the starting line CD (Fig. 1), so that, in all, 5 to 30  $\mu$ g of each tocopherol are present. The total solution set should not contain more than 100  $\mu$ g of total tocopherols. Use three replicate papers for each test sample and a fourth paper as a blank. The additions should be made from a fine-tipped glass capillary, calibrated by weight, from a 10- $\mu$ l blood pipette, from a Trenner pipette with a curved tip (Appendix I, 9) or from an Agla micrometer syringe. It is important to apply the solution as a regular band.

Into the first chromatographic tank pour enough 30 per cent. v/v benzene in cyclohexane to produce a depth of about  $\frac{1}{2}$  to 1 cm. Support test and blank papers with the dates at the top and their edges AE just immersed in the solvent. Leave the papers in the tank until the solvent front has migrated about 15 cm. This usually takes about 1 hour.

(e) *Second-dimension chromatography*—If no frame is being used, remove the papers individually from the first tank and dip each one in the liquid paraffin solution, with edge EH at the bottom, to within  $\frac{1}{2}$  cm of the line DG. If a frame is used, remove it with the papers from the first tank, and, with edges EH at the bottom, immerse the assembly in a bath of the liquid paraffin solution to within  $\frac{1}{2}$  cm of the line DG. Remove the papers from the paraffin solution, drain, and allow the light petroleum to evaporate in the air. Then place the papers in the second tank with edge AF just immersed in the 75 per cent. ethanol as the mobile phase. Run the papers for 2 to 3 hours or until the front has migrated to within 4 or 5 cm from the top of the papers.

Remove the papers from the tank, and dry them by means of a current of nitrogen or air.

(f) *Removal of spots from chromatograms*—Remove the papers from the frame, if one is used. Use either of two methods for spot location and removal for analysis. Method (i) is much to be preferred, but method (ii) can be used when no ultra-violet lamp is available. Even when method (i) is used, it is still desirable to spray one of the papers as in the first part of method (ii) in order to confirm the position of reducing spots.

- (i) Examine the dry papers in a dark room under ultra-violet light; the lamp should not be nearer to the paper than 10 cm. (See Appendix I, 8.) Tocopherol spots are visible as dark patches on a fluorescing background, less than  $1 \mu\text{g}$  being easily detected. (See Fig. 2.) Mark the spots by ringing with a hard pencil as quickly as possible, with a slight margin round each spot. Remove the paper, and cut out the marked spots with sharp scissors, cutting within the pencilled lines. With the minimum of handling, roll the cut-out pieces of paper into cylinders and drop each one separately into a numbered test-tube (measuring about  $10 \text{ cm} \times 1.5 \text{ cm}$  and fitted with a B14 ground-glass stopper) containing 3 ml of ethanol and 0.5 ml of the dipyrindyl solution. (See Appendix I, 6.) Mark the blank chromatogram correspondingly, and cut out the blank areas similarly.

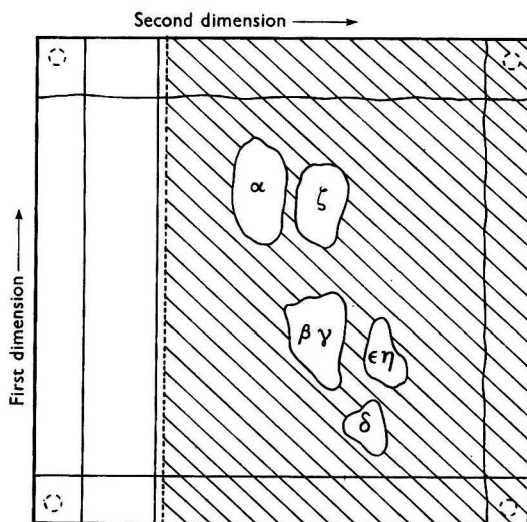

Fig. 2. Reproduction, one-third full size, from a paper, marked to show the positions of tocopherol zones after two-dimensional chromatography. The shaded area shows the part of the paper impregnated with paraffin after running in the first dimension. The wavy lines show approximate levels reached by the solvent fronts

- (ii) Spray one of the test papers heavily from a fine glass atomiser with the mixed reagent (equal parts of the ferric chloride solution and the dipyrindyl solution). Tocopherols appear as red spots, which should be ringed with a hard pencil. If no ultra-violet lamp is available use these spots to locate tocopherols on the assay papers. Remove the sprayed spots and a generous margin by cutting outside the pencilled rings, and use the resulting series of holes as a template for marking another test paper, and a blank paper. Alternatively, trace the sprayed paper on to a clean sheet of thin paper, and use the latter as a template. Having marked the tocopherol positions, cut out the areas from both test and blank papers, and drop them into tubes containing dipyrindyl solution, as in (i) above.

##### 5. *Positions of the spots on the chromatogram*—

The seven tocopherols separate as shown in Fig. 2. Depending on the material being analysed, one spot or several spots may be visible. Although by this method,  $\beta$ - and  $\gamma$ -tocopherol are inseparable, as are  $\epsilon$ - and  $\eta$ -tocopherol, instructions for their distinction are given in Appendix I, 7. Other spots appearing on the papers are normally distinguished from the

tocopherols by their positions. It must be emphasised that, depending on the degree of purification of the sample and the relative proportions of the different tocopherols present, some distortion of the movements of the spots may occur. Absolute  $R$  and  $R_F$  values may be disregarded, however; provided separation occurs according to the general pattern shown in Fig. 2, the next stage may be carried out. If separation is unsatisfactory, or recognition difficult, consult Appendix II.

#### 6. Colorimetric determination—

Gently swirl the stoppered test-tubes, each containing 3.5 ml of ethanolic dipyrindyl solution and the slip of paper, for a few seconds. Transfer to a darkened room, and carry out the rest of the determination under dim *artificial* light. To one of the solutions add 0.5 ml of the ferric chloride solution from a fast-delivery pipette, shake the stoppered tube for a moment, and then transfer the contents to a glass spectrophotometer cell 1 cm in path length. Exactly 2 minutes after adding the ferric chloride, measure the extinction at 520  $m\mu$  against a similar cell containing ethanol. Repeat this procedure with each tube. Subtract the reading of each "blank" tube from the reading obtained from the corresponding "test" tube. This gives the "net extinction" reading. Multiplication of the net extinction reading by the spectrophotometric factor for the tocopherol being measured gives directly the number of micrograms of tocopherol in the cut-out spot.

#### 7. Blanks—

The tocopherol-containing solution has been indirectly measured against a corresponding blank solution. The highest accuracy can only be obtained, therefore, if it can be safely assumed that the blank reaction of the mixed reagents is identical in both "blank" and "test" tubes. The "blank" has two components, namely (a) that derived from the residual reducing material in the paper, and (b) the reaction between the dipyrindyl and traces of ferrous iron in the ferric chloride. Component (a) amounts to an extinction of about 0.010 (see Appendix I, 3); component (b) can be reduced to about 0.050 by suitable precautions, such as preparing and keeping the ferric chloride solution in the dark and the observance of scrupulous cleanliness in the use of the pipettes for ferric chloride. Ferric chloride is converted to the ferrous state photochemically; hence the solution should not be exposed to daylight in transparent glass. The total blank value can be reduced to about 0.060 to 0.080. Blanks that give extinctions of over 0.100 are likely to be unstable and should be suspect. If high blank values continue, and other forms of contamination have been eliminated, it is best to prepare a new ferric chloride solution in a dark bottle previously cleaned with chromic acid solution.

#### 8. Calculations—

Where  $G$  = grams of oil taken,

$V$  = volume of benzene in millilitres to prepare solution for paper chromatography,

$v$  = volume in microlitres spotted on paper,

$D$  = net extinction, and

$F$  = spectrophotometric factor for 4 ml,

then each tocopherol, in micrograms per gram, is given by—

$$\frac{D \times F \times V \times 1000.}{v \times G}$$

The recommended factors,  $F$ , are—

$\alpha$ -tocopherol	98
$\beta$ -tocopherol	96
$\gamma$ -tocopherol	90
$\delta$ -tocopherol	75
$\epsilon$ -tocopherol	96
$\zeta$ -tocopherol	94
$\eta$ -tocopherol	88

The  $\beta$ - and  $\epsilon$ -tocopherol are determinable when spots in their respective positions give no colour on spraying with the dianisidine reagent. (See Appendix I, 7.) However, if the dianisidine reaction shows the presence of  $\gamma$ - or  $\eta$ -tocopherol the analyst may either assume that  $\beta$ - and  $\epsilon$ -tocopherol are absent or attempt a differential analysis of the four substances by chromatographic separation of nitroso-derivatives, such as has recently been described by Marcinkiewicz and Green.<sup>28</sup> Factors for  $\gamma$ - and  $\eta$ -tocopherol should be used even though  $\beta$ - or  $\epsilon$ -tocopherol, or both, may be present but masked.

## Appendix I

### NOTES ON TECHNIQUE AND APPARATUS

#### 1. ETHER—

Normally, ether is stabilised by adding to it a small amount of a reducing substance that prevents peroxide formation. The reducing substance does not affect tocopherol analysis; it is removed during washing after saponification or during floridin earth purification. If, however, the ether has been in the laboratory for a long time, it may contain peroxides. These may be removed by the method of Werner.<sup>29</sup> Shake 500 ml of ether for 6 minutes with a mixture of 4 g of silver nitrate in 30 ml of water and 2 g of sodium hydroxide in 50 ml of water, allow the phases to separate, decant and use the ether without distillation.

#### 2. REMOVAL OF STEROLS—

If it is required to remove sterols before treatment of the unsaponifiable fraction by chromatography on floridin earth, proceed as instructed below.

Dissolve the unsaponifiable residue in boiling methanol (analytical-reagent grade), and transfer the solution to a 15-ml centrifuge tube, using, in all, 12 ml of solvent. Cool to about  $-10^{\circ}\text{C}$  in a suitable bath, remove the precipitate by centrifugation in a previously cooled centrifuge cup, and pour the supernatant liquid into a flask. Redissolve the sterol precipitate in 5 ml of hot methanol, and repeat the process twice. Evaporate the combined methanol solutions to dryness under reduced pressure. Dissolve the residue in 5 ml of benzene.

#### 3. TREATMENT OF FILTER-PAPER—

Some batches of chromatographic paper have contained reducing material that raised the blank value. This may be removed by continuous extraction of the paper with hot methanol in a Soxhlet apparatus or by extraction and decantation in a measuring cylinder.

#### 4. PREPARATION OF ZINC CARBONATE IMPREGNATED PAPERS—

Zinc carbonate paper of sufficient activity can be prepared by drying in the atmosphere overnight (providing the relative humidity is not too high) instead of in an oven, but oven drying gives the more active paper.

Two members of the Panel (R. J. W. and V. H. B.) have found that Whatman No. 4 filter-paper has the advantage that it permits faster running in both dimensions. A word of caution is necessary. These papers are considerably thicker than No. 1 papers and, after removal from the second tank, retain more moisture. Small amounts of water increase the blank reading,<sup>30</sup> and care must be taken to see that these papers are completely and evenly dried before cutting. Drying is comparatively simple if single papers are used, but if several papers are in a frame, they should be stood in a gentle stream of nitrogen for at least 20 minutes.

#### 5. CHROMATOGRAPHY TANKS AND FRAMES—

A suitable chromatographic tank and frame for supporting the papers is that manufactured by Shandon Scientific Co., under the name Multi-Sheet Frame Chromatank. A similar assembly, in stainless steel with polythene spacers, is manufactured by Baird and Tatlock Ltd. The aluminium dish normally supplied is not necessary. Since the two-dimensional chromatography used in the recommended method differs in several respects from normal two-dimensional chromatography, a more useful type of frame can probably be made specially for it. (See also above, Analytical Procedure, 4 (c), p. 362.)

#### 6. DIPYRIDYL SOLUTION—

When large numbers of tubes are to be filled, it is convenient to use 3.5 ml of 0.07 per cent. 2:2'-dipyridyl solution instead of 0.5 ml of 0.5 per cent. dipyridyl solution plus 3 ml of ethanol. This solution is conveniently dispensed from a 3.5-ml automatic pipette.

#### 7. DETECTION OF $\gamma$ -, $\eta$ - AND $\delta$ -TOCOPHEROL BY DIAZOTISED *o*-DIANISIDINE—

*Sodium carbonate*—A 5 per cent. w/v solution in water.

*Diazotised o-dianisidine*—Dissolve 0.5 g of *o*-dianisidine dihydrochloride in 60 ml of water. Add 6 ml of hydrochloric acid, sp.gr. 1.18, and then 12 ml of 5 per cent. aqueous sodium nitrite solution. Mix thoroughly. After 5 minutes add 12 ml of 5 per cent. aqueous urea solution.

Spray one of the test papers (it is advisable to run an extra paper if the presence of  $\gamma$ -,  $\eta$ - or  $\delta$ -tocopherol is suspected) heavily with the sodium carbonate and then with the diazotised *o*-dianisidine from a fine glass atomiser. The tocopherols may be identified by the resultant colours<sup>25</sup>:  $\gamma$ -, blue-green changing to indigo;  $\eta$ -, brownish purple changing to purple;  $\delta$ -, reddish brown changing to purple. The colours may be stabilised by washing the papers in water after spraying.

The presence of colour in either the  $\gamma$ - or the  $\eta$ -position does not exclude the presence of  $\beta$ - or  $\epsilon$ -tocopherol, respectively.

#### 8. DETECTION OF SPOTS BY ULTRA-VIOLET LIGHT—

A suitable lamp for this purpose is one emitting light with a waveband around 254 m $\mu$ , such as the Shandon Chromatolite. A new lamp should be run for 2 or 3 hours before being put into use for ultra-violet location of tocopherols on paper. Other sources of ultra-violet illumination have been found suitable.

#### 9. SPECIAL GLASSWARE—

The 3.5-ml automatic pipette, Trenner pipettes, chromatographic tubes for floridin earth columns and glass atomisers for spraying chromatograms may be obtained from V. C. Ward, Church Street, Little Shelford, Cambridge.

## Appendix II

### SOME DIFFICULTIES AND SOME SUGGESTIONS

#### SAPONIFICATION AND EXTRACTION—

After the saponification has been completed, the extraction of the tocopherols into ether must be carried out as rapidly as possible, the aim being to achieve clean, fast separation of the two phases at every stage. Sometimes emulsions are formed; they can usually be dispersed by adding a few millilitres of ethanol. If they persist, it may be because the directions have not been followed closely enough; the proportions of reagents are somewhat critical, and too much ethanol may even encourage the formation of emulsions. Vigorous shaking at any stage is unnecessary and should be avoided, especially as some biological materials are naturally rich in emulsifying agents.

#### FLORIDIN EARTH CHROMATOGRAPHY—

Occasionally a batch of floridin earth may be found with too slow a percolation rate for column chromatography. This fault is difficult to remedy; in practice it is simplest to procure another batch.

Carotenoids, vitamin A and its derivatives, sterols and some other substances are adsorbed on floridin, producing a green, blue or red band. Sometimes, when the eluate is yellow or the coloured band reaches the bottom of the column, subsequent paper chromatography may be unsatisfactory. This may be because the column was developed too fast; or the ethanol used in its preparation contained water; or possibly the column was overloaded, too large a sample of oil having been saponified.

The "activity" or adsorptive power of the column depends chiefly on the fineness of the particles and the extent of dehydration produced by washing with ethanol. The conditions recommended in the method described here give an active column, suitable for removing most normal amounts of interfering substances. It may occasionally be found, if an extremely active batch of floridin is used, that even 35 ml of benzene is insufficient to elute all the  $\delta$ -tocopherol, which is the most strongly adsorbed tocopherol; if so, increase the amount of benzene to 40 or even 45 ml.

#### PAPER CHROMATOGRAPHY—

(a) *Exploratory techniques*—An analyst first practising the method and unfamiliar with paper chromatography will find it a good plan to chromatograph first a solution of  $\alpha$ -tocopherol and then a solution containing a known mixture of tocopherols. Reference solutions are best prepared in benzene and, for convenience, should contain about 1 mg of each tocopherol per ml. They may be kept in a refrigerator without appreciable deterioration.

In analysing a specimen of oil whose tocopherol content cannot be approximately guessed it is often advisable in step 4 (*d*) to apply a different amount of the benzene solution to each

of two or three papers. When the developed chromatograms are scanned, the one with the optimum amount of each tocopherol can be recognised easily after a little practice. It is sometimes useful to survey an unknown solution by a preliminary run on a single-dimensional zinc carbonate paper strip or, more rarely, to run a preliminary paraffin-coated strip. These preliminary runs give information about the tocopherols present and their separations. It must be emphasised that either single-dimensional procedure is for guidance only.

(b) *The use of tracers*—Sometimes a lipid is encountered containing uncommon proportions of tocopherols or excessive amounts of unusual impurities. Such material may produce a distorted paper chromatogram, on which the spots are sufficiently displaced to make difficult the identification of tocopherols by position alone. If this occurs, a duplicate paper, to which small amounts of  $\alpha$ -,  $\gamma$ - or  $\delta$ -tocopherol have been added to act as tracers, may be of use. It should be prepared as follows. Add from a micro-pipette, along the starting line CD of chromatographic paper, about 10  $\mu\text{g}$  of each tocopherol being investigated. The solutions of tocopherols in benzene, described above, are convenient for this purpose, 10  $\mu\text{l}$  being a satisfactory amount to add to the paper. Then add the test solution in the usual fashion. It is important that the tracers be added first, to ensure their even solubility in the small amount of test solution. Prepare a test paper, omitting the tracers, and run both papers together. The tracer tocopherols will migrate to the same positions as those in the test solution when they are identical with them.

(c) *Unsatisfactory chromatograms*—If the developed papers are still damp with aqueous solvent, observation of the spots under ultra-violet light is unsatisfactory.

If the tocopherols seem to have migrated too far in the first dimension or if they are poorly separated, it may be because the papers are stale; the zinc adsorbent deteriorates in time, especially in a humid atmosphere. If the tanks are shallow and are not lined with filter-paper, excessive evaporation of solvent from the front may occur; this causes fast running and poor separation of bands. Alternatively, the solvent in the first tank may need modifying. It has been found that, under the conditions that obtain in some laboratories, 25 per cent. of benzene in *cyclohexane* is sufficient. If the tocopherols do not appear to have migrated enough, it may be necessary to increase the benzene to 35 per cent. Some members of the Panel consider that 0.5 per cent. of ethanol in *cyclohexane* produces as good chromatograms as do the benzene - *cyclohexane* mixtures, but this percentage is somewhat critical and difficult to maintain in the tank. If the migration of the tocopherols in the second dimension is grossly abnormal, the solvent in the second tank may be at fault: it should be changed.

If papers show ill-defined spots of unexpected shapes or in the "wrong" places, it may well be that the papers have been overloaded, possibly with tocopherol, but more probably with other lipid materials. Spots that absorb ultra-violet light and do not reduce ferric chloride, as well as spots that fluoresce, are not tocopherols. If large amounts of interfering substances are observed on the paper, saponification may have been incomplete or the treatment with floridin earth ineffectual or the oil one requiring the "removal of sterols" step.

When lipids of very low potency (say, less than 0.05 mg of total tocopherols per g) are being analysed, two further difficulties in the paper chromatography are occasionally encountered, particularly if the lipids have been extracted from certain animal tissues. Even when purification according to the recommended method (including the "separation of sterols" step) has been performed, the residual tocopherol fraction may contain substantial amounts of hydrocarbons and other inert material. Because of the low tocopherol content of the sample, the fraction has to be added to the starting line of the paper in such an amount that not only does the first dimension become clogged for several centimetres along its length, but also an immiscible barrier may form at the paraffin boundary along the line DG. Tocopherols may be trapped in the barrier; if this happens, no separation will take place. Sometimes the phenomenon leads to streaking over a large area of the paper. One device that has proved successful in dealing with many of these difficult materials is a modification of the floridin earth purification. After normal preparation of the column, including the wash with five portions of 5 ml of benzene, pass 25 ml of light petroleum (40° to 60° C) through the column. Dissolve the tocopherol residue from step 1 (or, more usually with these difficult materials, step 2) in 5 ml of light petroleum, and add the solution to the top of the column. Develop the column with 25 ml of light petroleum. Discard the filtrate, which contains many of the interfering substances, and elute the tocopherols with the normal 30 ml of benzene.



## SPECTROPHOTOMETRIC FACTORS—

The factors given in the recommended method have been obtained as a result of careful study in several laboratories, and it is unlikely that the individual analyst will want to determine them for himself. The determination of tocopherols by the ferric chloride - dipyrindyl oxidation method is affected slightly by conditions that vary from laboratory to laboratory; in the opinion of the Panel, the recommended procedure has eliminated most of these effects as causes of variation. Those that remain—due to variations in temperature, humidity and purity of reagents—are not normally under control; in any event, the factors are not likely to vary by more than 2 per cent. between different laboratories. If the analyst should wish, for the most accurate work, to determine any factor in his own laboratory, he should procure a sufficiently pure specimen of the tocopherol concerned and carry out some determinations daily for a while at two or three different levels of tocopherol. In practice, he is most likely to be interested in the accurate determination of  $\alpha$ -tocopherol.

## GENERAL PRECAUTIONS—

The tocopherols are reasonably stable substances. They are most vulnerable to oxidation in the presence of traces of alkali, and the necessity for care and speed during the saponification stage has already been stressed. Strong light, abnormally high temperatures and the presence of ozone or ammonia in the air have all been found to affect the tocopherols during paper chromatography. Chromatograms should not be left in the dry state for longer than necessary. For useful information on paper chromatography, including hints on cleanliness in handling papers, consult Mitchell.<sup>31</sup>

If an analysis cannot be completed in a day, it is advisable to interrupt the procedure after saponification and extraction, or after floridin treatment, and to store the benzene solution in a refrigerator.

## Appendix III

### COLLABORATIVE TESTS

In the course of 5 years' work, the members of the Panel carried out 20 different collaborative tests, the numbers participating ranging from three to seven. Every stage of the recommended method was checked, and the determinations included both recovery experiments and analyses of "unknown" samples. It is not proposed to attempt here to summarise all these tests, but it seems desirable to illustrate by example the kind of work done and the kind of results obtained. We have therefore selected for presentation, as Tables II and III, tests designed to settle two specific issues, both of which have been canvassed in connection with already published methods of tocopherol determination. They deal with the practicability of quantitative tocopherol recovery after the recommended saponification procedure and with the ability of the floridin earth adsorption to remove interfering substances without loss of tocopherol.

## EXAMINATION OF SAPONIFICATION PROCEDURE—

A sample of wheat-germ oil was saponified by the recommended procedure. The non-saponifiable fraction was dissolved in ethanol and total reducing substances were measured, as if they were all  $\alpha$ -tocopherol, by the recommended procedure. The analysis was repeated, after adding 1.5 mg of  $\alpha$ -tocopherol to the 1 g of oil taken. Each determination was made at two levels and reported as "tocopherol equivalent" in mg per g of oil. Table II summarises the results. The mean recovery was 95.4 per cent., and the standard error of this mean was  $\pm 1.5$  per cent. The difference of the mean recovery from 100 per cent. is, therefore, significant ( $P > 0.05$ ) and shows that a small loss may occur during saponification.

## EXAMINATION OF SEPARATE AND COMBINED PROCEDURES FOR SAPONIFICATION, FLORIDIN EARTH TREATMENT AND STEROL REMOVAL—

A gram of wheat-germ oil was saponified; its "tocopherol equivalent" was determined and expressed as mg per g. (Result *a*, Table III.) A gram of wheat-germ oil was saponified; the non-saponifiable fraction was purified by chromatography on floridin earth by a modification of the recommended method. The "tocopherol equivalent" was measured. (Result *b*.)

TABLE II  
RECOVERY OF TOCOPHEROL ADDED TO AN OIL BEFORE SAPONIFICATION

Laboratory	"Tocopherol equivalent," mg per g	Recovery of added
		$\alpha$ -tocopherol, %
B	2.80	94
C	2.95	92
D	2.88	95
E	2.87	97
F	2.87	100

TABLE III  
RECOVERY OF TOCOPHEROL AFTER FLORIDIN EARTH TREATMENT AND STEROL REMOVAL  
"Tocopherol equivalent," mg per g of oil

Laboratory	"Tocopherol equivalent," mg per g of oil				
	<i>a</i>	<i>b</i>	<i>c</i>	<i>a</i> - <i>b</i>	<i>b</i> - <i>c</i>
B	2.94	2.71	2.63	0.23	0.08
C	3.08	2.69	2.64	0.39	0.05
D	2.93	2.69	2.69	0.23	0.00
E	2.73	2.68	2.63	0.05	0.05
F	2.88	2.72	2.51	0.16	0.21
G	2.79	2.63	2.69	0.16	-0.06

A gram of wheat-germ oil was saponified; the sterols were removed from the non-saponifiable fraction by the recommended procedure. The purified tocopherol fraction was then chromatographed on floridin earth and the "tocopherol equivalent" was measured. (Result *c*.)

The three groups of results in Table III express analyses at different stages of the recommended method. The figures under *a* - *b* do not signify a real loss of tocopherol, since the floridin earth column is intended to remove non-tocopherol reducing substances (which appear in the "tocopherol equivalents" as expressed in column *a*). The values under *b* - *c*, on the other hand, suggest a possible small loss of tocopherols during removal of sterols by freezing, but the difference between the means is not significant.

During statistical examination of the results obtained in this test, duplicate and triplicate determinations in individual laboratories were studied. The internal precision ("repeatability," within laboratories) was significantly higher than the external precision ("reproducibility," between laboratories).

#### RECOVERY TESTS—

A typical commercial oil was fortified with additional amounts of tocopherols. Samples of each oil, fortified and unfortified, were sent to each collaborator for analysis by the recommended method. The results are shown in Table IV.

TABLE IV  
RECOVERY TEST ON TOCOPHEROLS ADDED TO AN OIL\*

Oil X was produced by the addition of natural  $\alpha$ -,  $\gamma$ - and  $\delta$ -tocopherol to oil V. The amounts added per gram of oil were  $\alpha$ -, 186  $\mu$ g;  $\gamma$ -, 191  $\mu$ g;  $\delta$ -, 166  $\mu$ g

Laboratory	Tocopherols found in oil V		Tocopherols found in oil X			Recovery of —		
	$\alpha$ , $\mu$ g per g	$\gamma$ , $\mu$ g per g	$\alpha$ , $\mu$ g per g	$\gamma$ , $\mu$ g per g	$\delta$ , $\mu$ g per g	$\alpha$ , %	$\gamma$ , %	$\delta$ , %
B	302	378	500	605	166	106	118	100
D	325	432	489	612	130	88	95	79
	337	442	532	667	152	105	117	92†
F	333	409	513	596	155	97	98	94
	285	386	468	590	160	99	106	96†
	280	369	453	549	158	93	94	95†
G	235	273	366	479	86	70	108	57
H	262	381	458	525	64	105	76	39
	285	342	433	508	92	80	87	56

\* The only departure from the recommended method was that 30 ml of benzene were used for the elution from the floridin earth columns.

† No. 4 papers used (see Appendix I, 4).

Laboratories B, D, F and G had taken part in most of the previous tests and so were reasonably experienced in the recommended procedures. The dangers of arguing too much from tests of this kind are known to the Panel, but nevertheless it is believed that the results do bear out the satisfactory nature of the method as a whole. The results, apart from two of the figures for recovery of  $\delta$ -tocopherol, are considered to give a reasonably good forecast of those to be expected from other analysts. Laboratory H carried out the analyses of this test without any previous experience in the procedure and reported also that the work was done under "unusually difficult conditions." The results for  $\alpha$ - and  $\gamma$ -tocopherol obtained by this laboratory agreed well with the others, and in the Panel's view this is good evidence that the procedure recommended can be successfully followed by skilled analysts. The low recoveries of  $\delta$ -tocopherol reported by Laboratory H, and in two other analyses, were almost certainly due to incomplete elution from the flordin earth column. Since this collaborative test was completed, the volume of benzene recommended for the elution has been increased by 5 ml, which, in the opinion of members of the Panel, will avoid this snag.

#### COLLABORATIVE TEST ON THE FULL ANALYTICAL PROCEDURE FOR OILS—

The results in Table V record another collaborative test by members of the Panel. They illustrate some of the unavoidable vicissitudes encountered by those taking part as volunteer members in a collaborative analysis. It was originally planned that the two oils and the sample of chick meal should all be analysed by the approved method in six different laboratories, in duplicate by each analyst and when possible by more than one analyst in each laboratory. In the event, circumstances decreed that the tests could only be completed in three laboratories, for reasons that have no relevance to the validity of the methods used, and also that not every test could be done in duplicate. As some compensation for these defects, it was found possible in one laboratory for three analysts to examine all three samples. The departure from the originally planned scheme had as one consequence that no simple method of statistical evaluation could usefully be applied.

TABLE V  
TYPICAL SET OF RESULTS OBTAINED IN COLLABORATIVE TESTS

Laboratory	Tocopherols found in oil Y, $\mu\text{g}$ per g				Tocopherols found in oil Z, $\mu\text{g}$ per g				Tocopherols found in chick meal, $\mu\text{g}$ per g					
	$\alpha$	$\beta$	$\epsilon$	Total	$\alpha$	$\gamma$	$\delta$	Total	$\alpha$	$\beta$	$\epsilon$	$\zeta$	Total	
A	1827	757	156	2740	8	362	239	609	13.8	8.7	7.7	2.0	32.2	
	1810	743	69	2622	10	341	260	611						
	1713	830	92	2635	11	320	266	597						
B	1713	709	97	2519	8	292	223	523	14.2	9.2	7.0	1.8	32.2	
	Worker 1	1654	665	92	2411	8	288	199	495	14.0	10.0	6.7	1.6	32.3
		1647	705	137	2489	0	297	199	496	14.0	10.1	7.4	1.4	32.9
1647		705	137	2489	0	297	199	496	14.5	10.1	6.7	1.5	32.8	
Worker 2									12.5	9.7	7.2	1.5	30.9	
									13.5	10.6	6.9	0.6	31.6	
									12.8	9.6	6.9	1.3	30.6	
Worker 3									14.2	10.1	7.0	2.0	33.3	
	1640	600	70	2310	0	301	214	515	12.7	8.6	6.7	2.1	30.1	
					0	291	201	492	12.8	8.7	7.7	2.3	31.5	
C	1766	733	93	2592	30	328	230	588	15.4	10.8	7.8	2.3	36.3	
									15.4	10.5	8.0	2.0	36.2	
D	1718	705	55	2478	0	379	243	622						
	1737	767	66	2570	0	370	252	622						
					0	362	281	643						

#### REFERENCES

1. Karrer, P., and Fritzsche, H., *Helv. Chim. Acta*, 1938, **21**, 1234.
2. Green, J., personal communication.
3. Lehman, R. W., *Methods of Biochemical Analysis*, 1955, **2**, 153.
4. Quaife, M. L., and Harris, P. L., *Anal. Chem.*, 1948, **20**, 1221.
5. Bratzler, J. W., Loosli, J. K., Krukovsky, V. N., and Maynard, L. A., *J. Nutrition*, 1950, **42**, 59.
6. Eggitt, P. W. R., and Ward, L. D., *J. Sci. Food Agric.*, 1953, **4**, 569.
7. Quaife, M. L., and Harris, P. L., *Ind. Eng. Chem., Anal. Ed.*, 1946, **18**, 707.
8. Quaife, M. L., and Beihler, R., *J. Biol. Chem.*, 1945, **159**, 663.
9. Parker, W. E., and McFarlane, W. D., *Canad. J. Res.*, 1950, **18B**, 405.

10. Devlin, H. B., and Mattill, H. A., *J. Biol. Chem.*, 1942, **146**, 123.
11. Emmerie, A., and Engel, C., *Rec. Trav. Chim. Pays-Bas*, 1939, **58**, 283.
12. Kjölhede, K. Th., *Z. Vitaminforsch.*, 1942, **12**, 138.
13. Kaunitz, H., and Beaver, J. J., *J. Biol. Chem.*, 1946, **166**, 205.
14. Stern, M. H., and Baxter, J. G., *Anal. Chem.*, 1947, **19**, 902.
15. Hove, E. L., and Hove, Z., *J. Biol. Chem.*, 1944, **156**, 601.
16. Quaife, M. L., *Ibid.*, 1948, **175**, 605.
17. Polister, B. H., *Anal. Chem.*, 1954, **26**, 407.
18. Eggitt, P. W. R., and Norris, F. W., *J. Sci. Food Agric.*, 1956, **7**, 493.
19. Weisler, L., Robeson, C. D., and Baxter, J. G., *Anal. Chem.*, 1947, **19**, 906.
20. Green, J., and Marcinkiewicz, S., *Analyst*, 1959, **84**, 297.
21. Brown, F., *Biochem. J.*, 1952, **51**, 237; 1952, **52**, 523.
22. Eggitt, P. W. R., and Ward, L. D., *J. Sci. Food Agric.*, 1953, **4**, 176.
23. Green, J., Marcinkiewicz, S., and Watt, P. R., *Ibid.*, 1955, **6**, 274.
24. Tosic, J., and Moore, T., *Biochem. J.*, 1945, **39**, 498.
25. Green, J., *J. Sci. Food Agric.*, 1958, **9**, 801.
26. Datta, S. P., Dent, C. E., and Harris, H., *Biochem. J.*, 1950, **46**, xlii.
27. Watt, P. R., and Green, J., *Chem. & Ind.*, in the press.
28. Marcinkiewicz, S., and Green, J., *Analyst*, 1959, **84**, 304.
29. Werner, E. A., *Ibid.*, 1933, **58**, 335.
30. Hobson-Frohock, A., personal communication.
31. Mitchell, L. C., *J. Ass. Off. Agric. Chem.*, 1957, **40**, 999.

## A Polarographic Method for Determining Nitrate in Meat and Meat-curing Brines

By J. H. DHONT

(Central Institute for Nutrition and Food Research T.N.O., Utrecht, The Netherlands)

A polarographic method for determining nitrate is described; it is based on nitration of phenoldisulphonic acid and subsequent electrolytic reduction of the nitro compound at a dropping-mercury electrode, the diffusion current being proportional to the concentration of nitrate originally present. The effects of nitration time and interfering substances, such as chloride, nitrite and amino acids, the completeness of the nitration reaction and reproducibility have been investigated. The method is suitable for the determination of nitrate in brines contaminated with proteins.

THE determination of nitrates in heavily contaminated solutions, such as meat-curing brines, is of special interest in the meat industry, but constitutes a difficult analytical problem.

The usual polarographic procedures involve the catalytic action of polyvalent cations, such as molybdenum<sup>1</sup> or uranyl ion,<sup>2</sup> on the reduction of nitrate ion. Ingram<sup>3</sup> used cerium<sup>III</sup> ion for the polarographic determination of nitrate in brines. We found that organic compounds present in brines and meat extracts affected the polarographic wave obtained with molybdenum or uranyl ion. An irregular shift of the half-wave potential occurred, together with serious distortion of the reduction wave, and it was difficult or impossible to measure the diffusion current accurately.

Nitration of phenoldisulphonic acid results in the formation of 6-nitrophenol-2:4-disulphonic acid and an extremely small amount of picric acid.<sup>4</sup> This reaction forms the basis of many colorimetric procedures. It was shown that the nitro group of 6-nitrophenol-2:4-disulphonic acid was reducible at a dropping-mercury electrode and gave well defined waves, even in extremely acid solutions and in presence of organic material.

### EXPERIMENTAL

#### NITRATION REACTION—

The nitration of phenoldisulphonic acid by small amounts of potassium nitrate was carried out in the following way.

A 5.0-ml portion of standard nitrate solution was placed, by pipette, in a small Pyrex dish and evaporated to dryness on a bath of boiling water. To the residue were added 2 ml of phenoldisulphonic acid reagent solution (see "Reagents," p. 374), and the dish was replaced

on the water bath for a few minutes. The contents of the dish were then transferred to a 10- or 25-ml calibrated flask, cooled to room temperature and made up to the mark with water. After the solution had been thoroughly mixed, it was transferred to the electrolysis cell of a polarograph, and, after oxygen had been removed by passing nitrogen through the solution, a polarogram was recorded between 0.0 and -0.7 volt against a mercury-pool anode.

A nitration time of 3 minutes is sufficient at the temperature of the bath of boiling water; longer nitration times, up to 30 minutes, have no effect on the results.

Experiments showed that the nitration product is stable for at least 1 hour. After 6 hours, the diffusion current is too low, as can be seen from the following results—

Time after completion of nitration, hours	..	0.5	6	24
Diffusion current, arbitrary units	..	56.0	53.0	52.0

The relationship between diffusion current and nitrate concentration is linear, at least between 6.2 and 124 mg of nitrate per litre. The equation of the line was  $i = 4.85 c$ , where  $i$  is the diffusion current in arbitrary units and  $c$  is the nitrate concentration in parts per million; the standard deviation of the constant was  $\pm 0.0455$ .

Analytical experience suggests that a constant proportion of the nitrate reacts with phenoldisulphonic acid to form the nitro-derivative. Two methods were used to investigate the completeness of nitration. In one method, the nitro-derivative was formed from known amounts of potassium nitrate and was compared absorptiometrically with known amounts of 6-nitrophenol-2:4-disulphonic acid prepared by King's procedure.<sup>5</sup> In the other method, the nitro-derivative was formed in the same way and its electron uptake per mole was determined during reduction at a dropping-mercury electrode.

The absorptiometric measurements were made at 430  $m\mu$  with an Engel absorptiometer manufactured by Kipp, Delft, The Netherlands. The solutions of the nitro-derivative had a pH of 9.7.

The relationship between optical density and concentration was calculated from experiments in which small amounts of potassium nitrate were allowed to react with phenoldisulphonic acid and was found to be  $d = 0.2295 c$ , where  $d$  is the optical density and  $c$  is the concentration of nitrate in parts per million; the standard deviation of the constant was  $\pm 0.00630$ .

The equation found for solutions containing known amounts of 6-nitrophenol-2:4-disulphonic acid was  $d = 0.2271 c$ ; the standard deviation of the constant was  $\pm 0.00536$ . These equations show that the values obtained in the two experiments are all on the same straight line. This indicates practically quantitative reaction between phenoldisulphonic acid and nitrate under the conditions described.

Coulometric measurement of the electron uptake confirmed this conclusion. The number of electrons,  $n$ , participating in the electrode reaction was determined by a millicoulometric method recently described by Weaver and Whitnack.<sup>6</sup> As the concentration of the compound that is reduced enters into the calculation, the concentration of potassium nitrate used to nitrate the phenoldisulphonic acid can be used instead to control the completeness of the reaction. Three experiments with potassium nitrate solutions between 0.0001 and 0.0040  $N$  gave values of  $n$  equal to 5.8, 6.2 and 6.1.

The calculated value of  $n$  being 6, the reaction was assumed to be in accordance with the following equation—

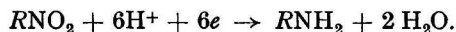

The pH in these experiments was 0.9 to 1.1, as measured by a hydrogen electrode.

Here, too, quantitative reaction between nitrate and phenoldisulphonic acid can be assumed.

#### INTERFERING SUBSTANCES—

Chloride ion commonly interferes in nitration reactions. A series of experiments was carried out with a phenoldisulphonic acid reagent solution consisting of 4 g of phenol, 4 g of water and 100 ml of concentrated sulphuric acid. When this solution was used, it was found that the diffusion current was strongly depressed when chloride ions were present during nitration.

When the amounts of water in the phenoldisulphonic acid reagent and in the residue were decreased, the effect of chloride ion on the nitration reaction also decreased.

The true diffusion current occurred when the residue was heated for a few minutes at 110° to 115° C before the phenoldisulphonic acid reagent solution was added and when, at the same time, 10 g of phosphorus pentoxide were added to the reagent solution. The reaction between hydrochloric and nitric acids does not apparently proceed in absence of water.

The presence of nitrite causes irregular deviations in the polarogram; nitrite must therefore be removed from the sample. This can be accomplished by treatment with urea at a pH of about 3. After 30 minutes, 0.05 per cent. of nitrite in the sample can be completely removed under these conditions.

Added amino acids were found to have no effect. The solutions used in these experiments contained 50 mg each of tyrosine, phenylalanine and glutamic acid and 47 µg of potassium nitrate per 10 ml.

Although tyrosine can be easily nitrated, no deviations were caused by the presence of the relatively large amount of this compound.

#### METHOD

##### APPARATUS—

A photographic recording Heyrovský-type polarograph manufactured by Laboratorní Pstroje, Prague, Czechoslovakia, was used.

##### REAGENTS—

*Phenoldisulphonic acid reagent solution*—Dissolve 4 g of crystalline phenol in 100 ml of concentrated sulphuric acid. When dissolution is complete, add 10 g of phosphorus pentoxide. The reagent is ready for use when the phosphorus pentoxide has dissolved; it may contain a slight precipitate, but this is of no importance.

*Hydrochloric acid, 19 per cent.*—Dilute 1 volume of hydrochloric acid, sp.gr. 1.19, with 1 volume of distilled water.

*Lead acetate solution, 20 per cent. w/v, aqueous.*

*Urea solution, 6 per cent. w/v, aqueous.*

*Standard nitrate solution*—Dissolve 0.200 g of potassium nitrate in water, and dilute to 100 ml in a calibrated flask.

##### PROCEDURE FOR BRINES—

Place 5 to 10 g of sample in a 250-ml calibrated flask, and add 1 ml of 6 per cent. w/v urea solution and 0.1 ml of 19 per cent. hydrochloric acid. Set aside for 1 hour at room temperature, and then dilute to the mark. Transfer 25 ml of the solution to a 50-ml calibrated flask, add 5 ml of 20 per cent. w/v lead acetate solution, dilute to the mark and filter.

Place 5 to 10 ml of the filtrate in each of two porcelain or borosilicate-glass dishes, and add 0.5 ml of standard nitrate solution to the contents of one dish. Evaporate the solutions to dryness on a bath of boiling water, heat the dishes for 3 to 5 minutes in an oven at 110° to 120° C, and allow to cool in a desiccator.

Add 2 ml of phenoldisulphonic acid reagent solution to each residue when cool, and place the dishes on a bath of boiling water for about 3 minutes. Carefully rinse the contents of each dish into a 10-ml calibrated flask with distilled water, and dilute to the mark when the solution has attained room temperature.

Pour the contents of the flask, including any precipitate that may have formed, into the electrolysis cell of a polarograph, and remove oxygen by passing a stream of nitrogen through the solution. Measure the diffusion current at 0.00 and -0.60 volt against the mercury-pool anode, and correct for the reagent blank value. Calculate the concentration of nitrate in the sample from the increase in diffusion current caused by the addition of the standard nitrate solution.

##### PROCEDURE FOR MEAT AND MEAT PRODUCTS—

Cut a 10-g sample into small pieces, and place in a 250-ml calibrated flask. Add 5 ml of 6 per cent. w/v urea solution and 0.5 ml of 19 per cent. hydrochloric acid, dilute to the mark with distilled water, and transfer the mixture to a Waring Blendor. Disintegrate the meat, and remove the suspended material by filtration. Place 40 ml of the filtrate in a 50-ml calibrated flask, add 5 ml of 20 per cent. w/v lead acetate solution, dilute to the mark, and filter. Continue as described under "Procedure for Brines," beginning at "Place 5 to 10 ml of the filtrate. . . ."

## DISCUSSION OF RESULTS

The height of the plateau of the polarographic wave obtained when phenoldisulphonic acid is nitrated in presence of brines and meat is affected by the presence of proteins, salts and fat; these constituents affect the viscosity and surface activity of the solution and may also influence the nitration reaction. However, when a standard addition of nitrate was made, as described, reproducibility was fairly good. Ten determinations on a solution containing 1.00 per cent. of potassium nitrate and 27 per cent. of sodium chloride gave a mean value of 1.006 per cent. of potassium nitrate with a standard deviation of  $\pm 0.039$  per cent. Eight sets of duplicate determinations on meat extracts containing from 0.36 to 1.43 per cent. of potassium nitrate had a maximum relative error of 6 per cent.

The proposed method was used in a series of recovery experiments on known amounts of potassium nitrate added to 10-g samples of meat; the results were as follows—

Amount of potassium nitrate added, % .. ..	0.312	0.780	1.00
Amount of potassium nitrate found, % .. ..	0.298	0.770	1.09
Recovery, % .. .. ..	95.5	98.7	109

TABLE I

## RECOVERY OF ADDED POTASSIUM NITRATE FROM COVER-BRINE

The sample of brine used contained 0.480 per cent. of potassium nitrate

Amount of potassium nitrate added, %	Total amount of potassium nitrate found, %	Amount of added potassium nitrate recovered, %	Recovery, %
2.22	2.66	2.18	99.0
1.11	1.57	1.09	99.0
	1.59	1.11	100.0
1.00	1.52	1.04	104.0
	1.422	0.942	94.2
	1.476	0.996	99.6

Another series of recovery experiments was carried out on known amounts of potassium nitrate added to a cover-brine containing 0.480 per cent. of potassium nitrate; the results are shown in Table I. A third series of recovery experiments was carried out on known amounts of potassium nitrate added to pump-brine containing 15 to 20 per cent. of sodium chloride; the results were as follows—

Amount of potassium nitrate added, % .. ..	1.00	1.00	1.50	0.950
Amount of potassium nitrate found, % .. ..	1.00	0.96	1.51	0.973
Recovery, % .. .. ..	100.0	96.0	99.4	102.3

The minimum amount of potassium nitrate that could be determined by the proposed method was 0.015 per cent.; in this instance, however, the relative error was 25 per cent.

I thank Dr. P. Hirsch-Ayalon and Mr. B. Krol for suggestions and advice during this investigation, and Miss J. Jongerden for carrying out many of the experiments.

## REFERENCES

1. Johnson, M. G., and Robinson, R. J., *Anal. Chem.*, 1952, **24**, 366.
2. Kolthoff, I. M., Harris, W. E., and Matsuyama, G., *J. Amer. Chem. Soc.*, 1944, **66**, 1782.
3. Ingram, M., *J. Soc. Chem. Ind.*, 1941, **60**, 126.
4. Chamot, E. M., and Pratt, D. S., *J. Amer. Chem. Soc.*, 1910, **32**, 630.
5. King, R., *J. Chem. Soc.*, 1921, **119**, 2105.
6. Weaver, R. D., and Whitnack, G. C., *Anal. Chim. Acta*, 1958, **18**, 51.

Received January 12th, 1959

## The Colorimetric Determination of Dieldrin in Extracts of Coffee Bark

BY E. JOHN SKERRETT AND E. A. BAKER

(Research Station, Long Ashton, Bristol)

Dieldrin is extracted from coffee bark and, after the removal of interfering plant material, is converted to the corresponding ketone by the action of boron trifluoride. The 2:4-dinitrophenylhydrazone is then formed and the red colour produced by interaction with tetraethylammonium hydroxide is measured at 440  $m\mu$ .

BORER beetles are responsible for serious damage in East African coffee plantations, young trees being especially susceptible to attack. In Tanganyika, a substantial measure of control has been achieved by spraying with solutions of dieldrin (HEOD<sup>1</sup>). As a corollary to these spraying measures, it was necessary to determine the level of insecticide residue on the bark of the tree in order to define the requirements for an efficient spraying programme.

The most widely used colorimetric method for the determination of dieldrin has been O'Donnell, Johnson and Weiss's phenyl azide procedure,<sup>2</sup> although Gunther, Kolbezen and Blinn<sup>3</sup> have reported the formation of a colour from 4 to 50  $\mu\text{g}$  of dieldrin by heating with *p*-nitrophenol. Other methods for determining dieldrin depend on the determination of the organically bound chlorine<sup>4,5</sup> or on infra-red absorption.<sup>6</sup> In seeking an alternative colorimetric method for dieldrin, the possibility of utilising the epoxy oxygen atom as the functional group for linkage to a chromophoric molecule was examined. Work on the chemistry of steroids<sup>7,8,9</sup> suggested that the boron trifluoride-ether complex might form a ketone, II, from the dieldrin molecule, I. Preparation of a 2:4-dinitrophenylhydrazone would then give a colour that could be measured after intensification with alkali.<sup>10</sup>

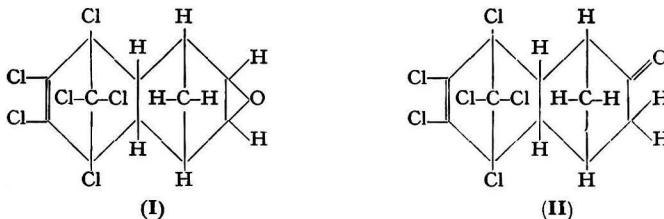

### EXPERIMENTAL

In preliminary experiments, solutions of the boron trifluoride-ether complex in benzene were used, in order to reduce the possibility of side reactions (see House and Wasson<sup>11</sup>). Although these experiments showed promise, blank values were high. Careful preparation of the complex from gaseous boron trifluoride and ether at low temperatures, recrystallisation of the 2:4-dinitrophenylhydrazine and rigorous purification and drying of all solvents greatly reduced this trouble. The reaction was carried out at 78° C for 30 minutes; this period was apparently the optimum, as shown by the following results—

Time of heating, minutes	..	..	..	10	20	30	60	120
Optical density of final colour	..	..	..	0.750	0.801	0.801	0.770	0.773

Tetraethylammonium hydroxide<sup>12</sup> was found to be a convenient alternative reagent to the customary ethanolic potassium hydroxide solution for colour development. The final colour reached a maximum after 1 minute and was stable for 10 minutes, as can be seen from the following results—

Time after colour development, minutes	1	2	3	4	5	10	20	30	60
Optical density	.. 0.716	0.715	0.715	0.714	0.714	0.715	0.710	0.710	0.690



Optical-density measurements were made with a Unicam SP600 spectrophotometer at 440  $m\mu$ , the maximum on the absorption spectrum, see Fig. 1.

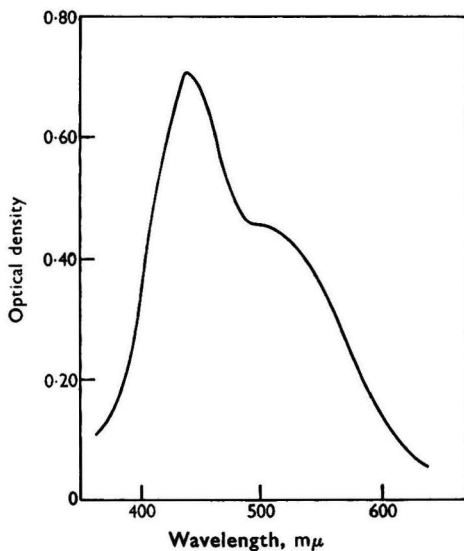

Fig. 1. Absorption spectrum of 2:4-dinitrophenylhydrazone in alkaline solution

For work on benzene extracts of coffee bark, it was necessary to remove plant pigments and waxes. Although interference from these sources was greatly reduced by passing the extract through an alumina column, preliminary treatment of the solution with calcium oxide and then active carbon was found to be necessary. The extract was then passed through a column containing alumina covered by a layer of anhydrous sodium sulphate to complete the removal of traces of water. However, when the most active grade of alumina was used, some of the insecticide was retained on the column. Adjustment of the activity to grade II (see Brockmann and Schodder<sup>13</sup>) minimised this effect and still achieved removal of the plant material.

A standard curve was prepared by applying the proposed method to known amounts of dieldrin added to benzene extracts of 10.4 sq. cm of bark surface. After subtraction of the blank value, the optical densities of the resulting solutions, measured in 1-cm cells, indicated a linear relationship of the form  $A = 4.20 \times 10^{-3} B$ , where  $A$  is the optical density and  $B$  is the number of micrograms of dieldrin present.

## METHOD

### REAGENTS—

*Boron trifluoride - ether complex*—Use the apparatus shown in Fig. 2. Place 10 to 25 ml of ether in flask A, and cool to  $-70^{\circ}\text{C}$  in a mixture of ether and solid carbon dioxide. Pass a slow stream of gaseous boron trifluoride (see Note) through the washing vessel, B, which is filled to the level shown with boron trifluoride - ether complex, and into flask A. Gently agitate the flask, and pass gas until fumes emerge from tube D. Store the complex at  $0^{\circ}\text{C}$  in a container of the type shown in Fig. 3, which permits the escape of any excess of boron trifluoride fumes; the fumes are corrosive.

NOTE—Formation of the complex is markedly exothermal; this necessitates gradual addition of boron trifluoride to avoid temperature increase. If the slow rate of gas flow results in "sucking back," this can be overcome by tilting flask A until the end of the tube is only just below the surface of the ether (it is helpful if the ground-glass joint at C is fitted with a polytetrafluoroethylene lining). Attempts to increase the flow rate of boron trifluoride apparently cause local overheating, and the resulting liquid, which has a distinct yellowish or brown tinge, gives a high blank value.

**Benzene**—Heat analytical-reagent grade benzene with 0.5 per cent. v/v of boron trifluoride - ether complex for 4 hours. Cool, wash three times with water, once with 10 per cent. sodium hydroxide solution and once more with water. Heat under reflux with 1 g per litre each of 2:4-dinitrophenylhydrazine and trichloroacetic acid<sup>14</sup> for 6 to 8 hours, and use a Dean and Stark trap to remove water. Fractionate, heat under reflux with potassium to remove final traces of water, and fractionate again.

**Ether**—Prepare in the manner described for benzene.

**Ethanol**—Fractionate commercial-grade absolute ethanol in presence of 1 g of 2:4-dinitrophenylhydrazine and 0.2 ml of hydrochloric acid, sp.gr. 1.18, per litre.

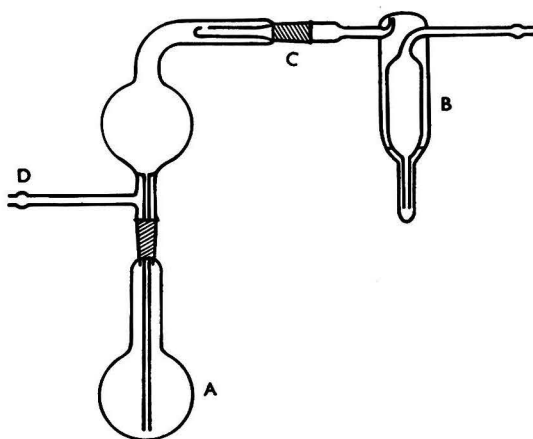

Fig. 2. Apparatus for preparing boron trifluoride - ether complex

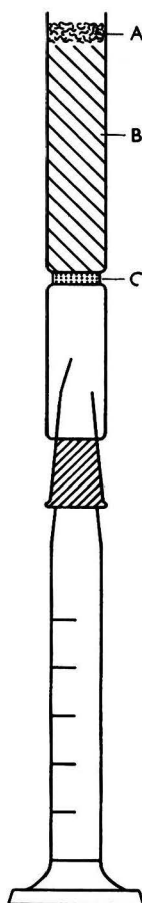

Fig. 3. Storage container for boron trifluoride - ether complex: A, glass wool; B, silica gel; C, sintered-glass disc

**2:4-Dinitrophenylhydrazine solution**—Dissolve 10 mg of analytical-reagent grade 2:4-dinitrophenylhydrazine that has been twice recrystallised from benzene in 5 ml of 20 per cent. v/v sulphuric acid. Prepare this solution freshly each day, and extract with 0.1 ml of benzene immediately before use.

**Calcium oxide**—Heat calcium carbonate (formed by precipitation with ammonium carbonate) for 8 hours at 820° C, and allow to cool in a desiccator over fresh phosphorus pentoxide.

**Alumina**—Stir H-grade alumina with approximately 0.02 N acetic acid at 80° to 100° C for 3 to 5 hours. Allow the mixture to settle, and decant the supernatant liquid. Repeat this procedure twice with 0.02 N acetic acid and once with water. Dry in an oven for 3 hours at 120° C, break up any lumps, and then heat at 600° C for 3 hours. Cool to 200° C, and store over phosphorus pentoxide. Adjust the activity to Brockmann grade II<sup>18</sup> by

placing a thin layer of alumina overnight in a closed vessel containing an amount of water equivalent to 1 per cent. of the weight of alumina. Use immediately, as grade II alumina deteriorates rapidly when stored.

*Carbon*—Stir 100 g of Darco G60 carbon (obtained from Darco Carbon Corporation, New York) with 200 ml of benzene for 30 minutes. Separate the carbon by filtration, and dry in air first at room temperature and then at 110° C for 4 hours.

*Tetraethylammonium hydroxide solution, 25 per cent. w/v.*

*Hydrochloric acid, sp.gr. 1.18.*

*Potassium hydroxide, 10 N.*

#### PROCEDURE—

Place approximately 10 sq. cm of coffee bark in a Soxhlet apparatus, and extract with benzene. After the third syphoning, concentrate the extract to 10 ml, add 0.5 g each of calcium oxide and Darco G60 carbon, and swirl intermittently for 5 minutes. Pour the mixture into a 15-mm internal diameter chromatographic tube containing 5 g of alumina covered by 5 g of anhydrous sodium sulphate. Wash the extraction flask and column with two 5-ml portions and one 15-ml portion of benzene, and evaporate the combined eluates to 5 ml. Cool, and add 1 ml of a freshly prepared (9 + 1) mixture of benzene and boron trifluoride-ether complex. Heat for 30 minutes at 78° C (preferably in an oil-bath to prevent reaction between the complex and water vapour), and then cool to 0° C. Add 20 ml of saturated sodium hydrogen carbonate solution, re-cool to 0° C in 10 minutes, and rinse into a separating funnel (stopcock lubricated with water only) with 5 ml of benzene. Shake vigorously for 30 seconds, discard the aqueous layer, wash with 25 ml of water, and again discard the aqueous layer. Dry the solution by slow passage through a 15-mm layer of anhydrous sodium sulphate, and wash the sodium sulphate with 15 ml of benzene. Remove the solvent by distillation in a water bath. Dissolve the residue in 0.5 ml of ethanol (warm slightly if necessary), add 0.1 ml of 2:4-dinitrophenylhydrazine solution, and set aside for 15 minutes. Add 5 ml of benzene, and transfer to a separating funnel. Wash successively with 10 ml of hydrochloric acid, sp.gr. 1.18, 5 ml of 10 N sodium hydroxide, 10 ml of hydrochloric acid, sp.gr. 1.18, and 20 ml of water. Pass the benzene layer through a 5-mm layer of anhydrous sodium sulphate into a 10-ml graduated glass cylinder fitted with a stopper, and wash the sodium sulphate with more benzene until the volume is 7.5 ml. Add 2.5 ml of ethanol and 1 drop (approximately 0.05 ml) of 25 per cent. w/v tetraethylammonium hydroxide solution, mix thoroughly by inverting the cylinder several times, and set aside for 1 minute. Measure the resulting colour in a 1-cm cell at 440 m $\mu$  with a Unicam SP600 spectrophotometer; use a solution similarly prepared from uncontaminated bark as blank.

#### RESULTS

Known amounts of dieldrin were added to the benzene extracts from 10.4-sq. cm portions of uncontaminated coffee bark to give samples corresponding to the range of insecticide concentrations likely to occur in practice. The results, which indicate recoveries between 98 and 106 per cent., were as follows—

Dieldrin added, $\mu$ g	..	50	50	50	100	100	150	150	200	200
Dieldrin found, $\mu$ g	..	53	51	53	101	100	150	147	201	199

Work on the application of the proposed method to spray residues of endrin is in progress.

We thank Professor H. G. H. Kearns and Dr. J. T. Martin for their interest in the work; we also thank the Imperial Smelting Company Ltd. for a gift of a cylinder of boron trifluoride, and members of their research department for guidance in its manipulation.

#### REFERENCES

1. "Recommended Common Names for Pesticides," British Standard 1831:1957.
2. O'Donnell, A. E., Johnson, H. W., jun., and Weiss, F. T., *J. Agric. Food Chem.*, 1955, **3**, 757.
3. Gunther, F. A., Kolbezen, M. J., and Blinn, R. C., *J. Econ. Ent.*, 1954, **47**, 185.
4. Ewart, W. H., Gunther, F. A., Barkley, J. H., and Elmer, H. S., *Ibid.*, 1952, **45**, 578.
5. Agazzi, E. J., Peters, E. D., and Brooks, F. R., *Anal. Chem.*, 1953, **25**, 237.
6. Garhart, M. D., Witmer, F. J., and Tajima, Y. A., *Ibid.*, 1952, **24**, 851.
7. Heusser, H., Eichenberger, K., Kurath, P., Dällenbach, H. R., and Jeger, I., *Helv. Chim. Acta*, 1951, **34**, 2125.
8. Heusler, K., and Wettstein, A., *Ibid.*, 1953, **36**, 398.

9. Bladon, P., Henbest, H. B., Jones, E. R. H., Lovell, B. J., Wood, G. W., and Woods, G. F., *J. Chem. Soc.*, 1953, 2921.
10. Lappin, G. R., and Clark, L. C., *Anal. Chem.*, 1951, 23, 541.
11. House, H. O., and Wasson, R. L., *J. Amer. Chem. Soc.*, 1956, 78, 4394.
12. Porter, C. C., *Anal. Chem.*, 1955, 27, 805.
13. Brockmann, H., and Schodder, H., *Ber.*, 1941, 74, 73.
14. Henick, A. S., Benca, M. F., and Mitchell, J. H., jun., *J. Amer. Oil Chem. Soc.*, 1954, 31, 88.

Received November 12th, 1958

## The Spectrophotometric Determination of Silica in Presence of Fluorine and Phosphorus

By S. GREENFIELD

(*Albright & Wilson (Mfg.) Ltd., Research Department, Oldbury, Birmingham*)

A method is described for determining silica in minerals containing phosphorus and fluorine. It is particularly applicable to phosphate rocks and the slags resulting from the electrothermal reduction of such rocks.

The method is based on the fact that fluorosilicic acid reacts with ammonium molybdate to form molybdosilicate, which is then reduced to molybdenum blue. Reduction of any molybdophosphate formed is prevented by careful control of acid concentration.

SILICON tetrafluoride is lost when silica is determined by dehydration from acid solutions of certain fluorine-containing slags and phosphate rocks. This difficulty can be overcome by the use of methods<sup>1</sup> involving alkaline fusion, water extraction and precipitation of silica by zinc nitrate and carbonate, but the time required is considerable. A possible alternative procedure was suggested by the fact that fluorosilicic acid,<sup>2</sup> like silicic acid,<sup>3</sup> reacts with ammonium molybdate to form molybdosilicic acid. The conditions for forming molybdosilicate also favour formation of molybdophosphate, although, at a sufficiently high acid concentration,<sup>4</sup> molybdosilicate can be reduced to molybdenum blue, but molybdophosphate and ammonium molybdate can not.

After the sample had been fused in sodium peroxide and the aqueous extract had been boiled to destroy the peroxides, it was proposed to pour the cooled extract into an excess of hydrochloric acid. In this way, it was thought, all the silica would be retained in solution as orthosilicic and hydrofluorosilicic acids; any polymerisation of silicic acid would be avoided, since the final solution would not approach pH 8 to 9, at which maximum polymerisation has been reported.<sup>5</sup> It was considered to be important to avoid polymerisation, as the higher silicic acids are less reactive to ammonium molybdate than is the monomeric form.<sup>5,6</sup> When molybdosilicate had been formed, the acidity of the solution could be increased and reduction to molybdenum blue effected.

### EXPERIMENTAL

#### FORMATION OF MOLYBDOSILICATE—

To ascertain the correct conditions for forming molybdosilicate, the hydrochloric acid content of an ammonium molybdate solution was varied from 0.1 to 0.6 *N*. When this solution was added to a standard silicate solution, the acidity of the final solution varied between 0.028 and 0.39 *N*. The optical densities of the coloured solutions so formed were measured in 1-cm cells with a Unicam SP500 spectrophotometer at an empirically chosen wavelength of 360 *mμ*. Maximum colour development occurred when the final solution was 0.17 *N* in hydrochloric acid, see Fig. 1. The time required for maximum colour development at this acidity is less than 4 minutes, and when colour development is complete, the optical density remains approximately unchanged for at least 180 minutes, which indicates that there is little, if any, polymerisation. Five minutes was finally chosen as a suitable development time. Under these conditions, the absorption maximum occurs at 352 *mμ*.

Many workers<sup>2,7,8,9</sup> have considered it necessary to add boric acid in order to complex fluoride before the molybdosilicate is formed, and it has been suggested<sup>10</sup> that fluoride

interferes by forming fluorosilicate complexes and that boric acid is necessary to de-complex the silica (low-stability fluoro complex) and so restore the colour. Under the conditions of this particular application of the molybdosilicate reaction, fluorine was without effect; this was verified by allowing aliquots of a standard silicate solution to react with ammonium molybdate under the conditions specified and measuring the optical densities of the coloured solutions so formed. This experiment was repeated after 3 mg of fluorine, as sodium fluoride, had been added to each solution. Finally, a series of determinations was made in which standard sodium fluorosilicate solution was used in place of the silicate solution. Each value of optical density, plotted as ordinate against silica content as abscissa, was on a single straight line.

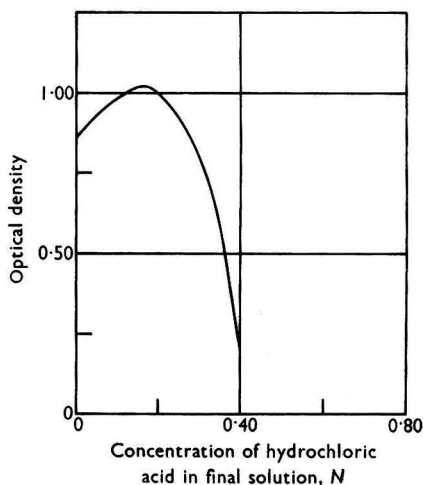

Fig. 1. Effect of acid concentration on formation of molybdosilicate. Final solution contained 50 ml of 1 per cent. w/v acidified ammonium molybdate solution and 20 ml of 0.004 per cent. w/v silica solution

#### REDUCTION OF MOLYBDSILICATE—

From previous experience, it was thought that stannous chloride could be used to reduce molybdosilicate to molybdenum blue. This was confirmed by experiment, and the resulting blue colour had absorption maxima at 636 and 800  $m\mu$ . It was apparent that measurements at 800  $m\mu$  would have greater sensitivity than those at 636  $m\mu$ , and the former wavelength was chosen.

The acidity at which molybdosilicate could be reduced by stannous chloride without reduction of ammonium molybdate or molybdophosphate was ascertained by adding 10-ml portions of a 1 per cent. w/v stannous chloride solution to solutions of ammonium molybdate in which the hydrochloric acid content varied from 1.0 to 3.0 *N*. This experiment was repeated with solutions of molybdosilicate and molybdophosphate. The optical densities of the solutions were measured against water in 1-cm cells at 800  $m\mu$  and all readings were corrected for dilution to 160 ml. The results showed that, when the solution was between 2.2 and 3.0 *N*, neither ammonium molybdate nor molybdophosphate was reduced to any great extent, whereas molybdosilicate was reduced to molybdenum blue, see Fig. 2 (a).

It was found later that, when phosphate and titanate were present together, the blue colour was intensified after reduction with stannous chloride, which suggested the formation of a complex with ammonium molybdate. This difficulty was overcome by setting the solution aside for 10 minutes after the acidity had been increased but before reduction. Fig. 2 (b) shows the effect of this modification on the results by the previous experiments. When it had been formed, the molybdenum blue was stable for long periods. Two minutes after the addition of stannous chloride solution to the molybdosilicate solution, the optical density was 1.048; it increased to 1.053 after 5 minutes and remained within  $\pm 0.002$  of this value for 30

minutes, after which a gradual decrease occurred, the optical density falling to 1.043 after 90 minutes. The effect of temperature is more noticeable, see Fig. 3.

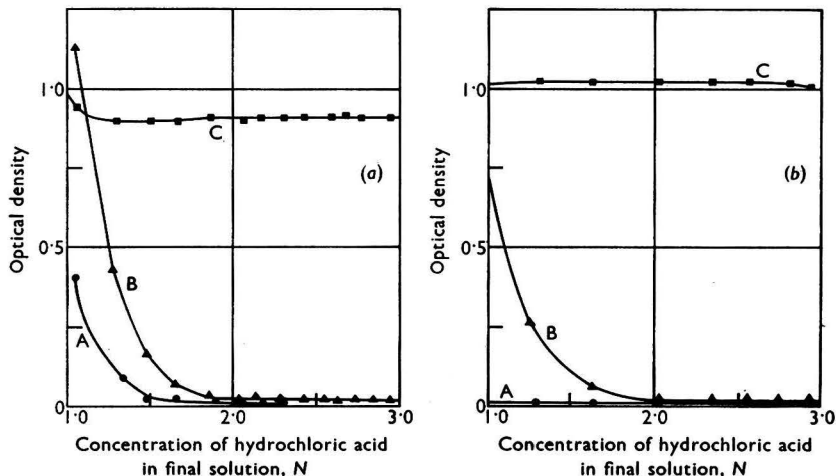

Fig. 2. Effect of acid concentration on reduction of ammonium molybdate, molybdophosphate and molybdosilicate (a) with no interval between increase in acidity and reduction, (b) with 10-minute interval: curve A, 50 ml of 1 per cent. w/v acidified ammonium molybdate solution and  $x$  ml of 50 per cent. v/v hydrochloric acid; curve B, 50 ml of 1 per cent. w/v acidified ammonium molybdophosphate solution, 20 ml of 0.0053 per cent. w/v potassium dihydrogen orthophosphate solution and  $x$  ml of 50 per cent. v/v hydrochloric acid; curve C, 50 ml of 1 per cent. w/v acidified ammonium molybdosilicate solution, 20 ml of 0.004 per cent. w/v silica solution and  $x$  ml of 50 per cent. v/v hydrochloric acid

After suitable fusion techniques had been devised and the necessary adjustments in acid concentrations had been made to counteract the alkalinity introduced, a calibration curve was prepared by using standard silicate solution, silicate solution with 6 mg of added fluorine, silicate solution with 15 mg of added phosphorus and standard sodium fluorosilicate solution.

All the points were on the same straight line, which indicates that the method is free from interference by amounts of fluorine and phosphorus equivalent to 6 and 15 per cent. w/w, respectively, in a 0.1-g sample.

#### METHOD

##### REAGENTS—

All reagents should be free from silica, and the solutions should be stored in polythene bottles.

*Ammonium molybdate stock solution*—Dissolve 50 g of ammonium molybdate in distilled water, and filter the solution, if necessary, into a 500-ml calibrated flask. Dilute to the mark at 20° C with distilled water.

*Hydrochloric acid, 4 N*—Standardise, and adjust accurately to 4 N.

*Ammonium molybdate solution, acidified*—By pipette, place 100 ml of stock ammonium molybdate solution and 75 ml of 4 N hydrochloric acid in a 1-litre calibrated flask, and dilute to the mark at 20° C with distilled water.

*Ammonium molybdate solution, 1 per cent. w/v, aqueous*—By pipette, place 50 ml of stock ammonium molybdate solution in a 500-ml calibrated flask, and dilute to the mark at 20° C with distilled water.

*Hydrochloric acid, 50 per cent. v/v*—By pipette, place 250 ml of hydrochloric acid, sp.gr. 1.18, in a 500-ml calibrated flask, and dilute to the mark at 20° C with distilled water.

*Silicate solution*—Fuse 1.0 g of pure silica with 10 g of anhydrous sodium carbonate in a platinum crucible. Extract the melt in a polythene beaker with distilled water, and when dissolution is complete, transfer the solution to a 1-litre calibrated flask. Dilute to the mark at 20° C with distilled water, and immediately transfer the solution to a polythene bottle.

*Stannous chloride solution, 1 per cent. w/v*—Warm 2.5 g of stannous chloride in 3 ml of hydrochloric acid, sp.gr. 1.18, until dissolution is complete. Cool, transfer to a 250-ml calibrated flask, and dilute to the mark at 20° C with distilled water.

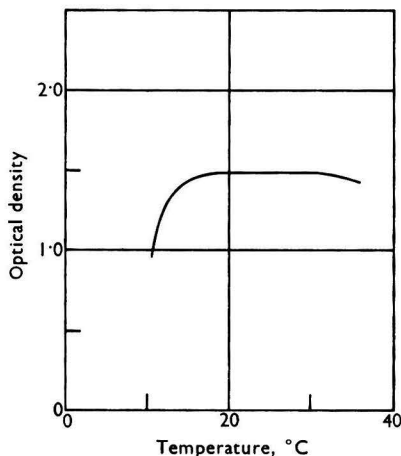

Fig. 3. Effect of temperature on formation of molybdenum blue

#### PROCEDURE FOR STANDARDISING SILICATE SOLUTION—

By pipette, place 50 ml of silicate solution in a platinum dish, acidify with hydrochloric acid, sp.gr. 1.18, and evaporate to dryness on a water bath. Moisten the residue with hydrochloric acid, sp.gr. 1.18, and add 25 ml of distilled water. Warm gently until the salts have dissolved, and filter the solution through a Green's No. 802 filter-paper into a polythene beaker. Wash the precipitate with distilled water, but do not rub the platinum dish with a rubber-tipped glass rod. Transfer the filtrate to the original dish, and again evaporate to dryness on a steam-bath. Heat the dish for 1 hour in an electric oven at 110° C. Cool, moisten with hydrochloric acid, sp.gr. 1.18, and add a little water as before. When the salts have dissolved, filter the solution through a Green's No. 803 filter-paper, and wash the precipitate with distilled water, but do not use a rubber-tipped glass rod. Combine the two filter-papers in the original platinum dish, heat until the papers char, and ignite the silica to constant weight at 1200° C in an electric muffle-furnace. Treat the residue with a few drops of dilute sulphuric acid and 2 to 3 ml of hydrofluoric acid, evaporate on the steam-bath, and remove the last traces of sulphuric acid on a hot-plate. Ignite to constant weight as before.

$$\text{Amount of silica present, g per ml} = \frac{\text{Loss in weight, g}}{50}$$

#### PREPARATION OF SAMPLE SOLUTION—

Fuse 3.0000 g of anhydrous sodium carbonate in a tall 10-ml platinum crucible. When molten, gently swirl to form an even lining that extends nearly to the top of the crucible. Cool slowly to avoid cracking the lining. Transfer 0.1000 g of sample and 0.5000 g of sodium peroxide to the crucible, and mix intimately with use of a platinum rod. Fuse at a temperature not above 750° C. Extract the melt in a covered 150-ml platinum dish with 50 ml of hot distilled water, and boil for 15 minutes. Cool to room temperature, and, with constant stirring, pour into a mixture of 55 ml of 4 N hydrochloric acid and 20 ml of cold distilled water in a 400-ml polythene beaker. Set the beaker aside until dissolution is complete, transfer to a 250-ml calibrated flask, and dilute to the mark at 20° C with distilled water. Rinse a polythene bottle two or three times with the solution, and store the remainder therein.

#### PROCEDURE FOR DETERMINING SILICA—

*Test solution*—By pipette, place 50 ml of 1 per cent. w/v aqueous ammonium molybdate solution in a dry 250-ml beaker, and add, also by pipette, 20 ml of sample solution. Set aside for 5 minutes  $\pm$  5 seconds at 20°  $\pm$  1° C. From a burette, add 60 ml of 50 per cent. v/v

hydrochloric acid, mix well, and set aside for 10 minutes  $\pm$  5 seconds at  $20^\circ \pm 1^\circ$  C. Add 10 ml of 1 per cent. w/v stannous chloride solution, and set aside for a further 5 minutes  $\pm$  5 seconds at  $20^\circ \pm 1^\circ$  C.

*Compensating solution*—By pipette, place 50 ml of 1 per cent. w/v aqueous ammonium molybdate solution in a dry 250-ml beaker, and add 60 ml of 50 per cent. v/v hydrochloric acid from a burette. By pipette, add 10 ml of 1 per cent. w/v stannous chloride solution and then 20 ml of sample solution. Set aside for  $20 \pm 1$  minutes at  $20^\circ \pm 1^\circ$  C.

Measure the optical density of the test solution against the compensating solution in 1-cm cells at 800  $m\mu$ , and determine the amount of silica in the sample by reference to a previously prepared calibration graph.

Carry out the entire method on a blank solution of the reagents.

#### PREPARATION OF CALIBRATION GRAPH—

Weigh accurately 2.0, 1.98, 1.96, 1.94, 1.92 and 1.90 g of anhydrous sodium carbonate into six 250-ml polythene beakers, and dissolve each portion in 100 ml of distilled water. Add to the six solutions 0, 2, 4, 6, 8 and 10 ml of standard silicate solution. Transfer the solutions to six NPL grade A 250-ml calibrated flasks, and dilute each to the mark at  $20^\circ$  C with distilled water. Store the solutions in polythene bottles.

Prepare test and compensating solutions as described above, but use acidified ammonium molybdate solution in place of 1 per cent. w/v aqueous ammonium molybdate solution. Measure the optical densities of the solutions against the compensating solutions, subtract the blank value, and plot a graph of corrected optical density against amount of silica present.

NOTE—The stipulated additions and conditions must be closely adhered to if the method is to be operated successfully.

TABLE I  
COMPARISON OF RESULTS BY THE PROPOSED AND GRAVIMETRIC PROCEDURES

Sample No.	Silica content, % w/w	Average silica content, % w/w	Procedure used
1	2.21, 2.22, 2.25	2.23	} Gravimetric
2	6.11, 6.09, 6.08	6.09	
3	10.60, 10.56, 10.59	10.58	
<i>In presence of added fluorine and phosphorus—</i>			
1	2.247, 2.246, 2.249, 2.246, 2.247, 2.249, 2.250, 2.251, 2.249, 2.247	2.248	} Spectrophotometric
2	6.080, 6.100, 6.075, 6.100, 6.125, 6.100, 6.103, 6.105, 6.100, 6.080	6.098	
3	10.30, 10.50, 10.35, 10.55, 10.30, 10.25, 10.30, 10.55, 10.50, 10.45	10.405	
<i>In absence of fluorine and phosphorus—</i>			
3	10.30, 10.30, 10.30, 10.20, 10.35, 10.55, 10.35, 10.45, 10.55, 10.55	10.39	

#### RESULTS AND CONCLUSIONS

In order to check the method, three slags were synthesised in an induction furnace; the slags contained approximately 50 per cent. w/w of aluminium oxide, 40 per cent. w/w of calcium oxide, 3 per cent. w/w of titanium dioxide, 0 to 10 per cent. w/w of silica and small amounts of iron oxide, sulphate, sulphide, magnesium oxide and alkalis. The silica contents of the slags, which were free from fluorine and phosphorus, were determined gravimetrically, every possible precaution being taken to ensure the accuracy of the analyses. The slags were then analysed by the proposed procedure, 3 per cent. w/w of both fluorine, as sodium fluoride, and phosphorus, as sodium dihydrogen orthophosphate, being added at the fusion stage; the determinations were carried out by an assistant who had only a few hours' experience of the method. Finally, one of the slags was analysed by the proposed method without any addition of fluoride or phosphate. The results of these experiments are shown in Table I, from which it can be seen that the proposed method is at least as accurate as the gravimetric method. It is also more rapid ( $2\frac{1}{2}$  hours), probably has a greater precision and is free from



interference by fluorine and phosphorus. The method has been used in these laboratories for 3 years.

I thank Mr. M. Attwood, who carried out nearly all of the experimental work.

#### REFERENCES

1. Hoffman, J. I., and Lundell, G. E. F., *Bur. Stand. J. Res.*, 1929, **3**, 581.
2. Case, O. P., *Ind. Eng. Chem., Anal. Ed.*, 1944, **16**, 309.
3. Jolles, A., and Neurath, F., *Z. angew. Chem.*, 1898, **11**, 315.
4. Vaughan, E. J., "Further Advances in the Use of the Spekker Photo-Electric Absorptiometer in Metallurgical Analysis," *Monograph*, The Institute of Chemistry, London, 1942, p. 6.
5. Richardson, E., and Waddams, J. A., *Res. Correspondence*, 1954, 7.
6. Weitz, E., Francke, H., and Schuchard, N., *Chem. Z.*, 1950, **74**, 256.
7. Lacroix, S., and Labalade, M., *Anal. Chim. Acta.*, 1949, **3**, 383.
8. Cade, G. N., *Ind. Eng. Chem., Anal. Ed.*, 1945, **17**, 372.
9. Brabson, J. A., Mattraw, H. C., Maxwell, G. E., Darrow, A., and Needham, M. F., *Anal. Chem.*, 1948, **20**, 504.
10. Charlot, G., and Bézier, D., "Quantitative Inorganic Analysis," Methuen & Co. Ltd., London, 1957, p. 568.

Received December 4th, 1958

## The Quantitative Determination of some Noble Metals by Atomic-absorption Spectroscopy

BY R. LOCKYER AND G. E. HAMES

(*Hilger & Watts Ltd., 98 St. Pancras Way, London, N.W.1*)

Silver, gold, platinum, rhodium and palladium have been quantitatively determined in concentrations down to 1 p.p.m. in solution. Reproducibility was good, and no inter-element effects were found, even when excesses of lead and iron were present. A complication peculiar to gold is described.

THE technique of atomic-absorption spectroscopy has been described recently.<sup>1,2,3,4</sup>

#### DESCRIPTION OF APPARATUS

Standard Hilger and Watts hollow-cathode lamps were used as line sources, the cathodes having liners made from the appropriate metal foil obtained from Johnson, Matthey & Co. Ltd. Power for the lamp was obtained from a Hilger FA41 stabilised-supply unit. A standard Uvispek H700 spectrophotometer fitted with a Hilger H909 atomic-absorption attachment was used. This is a new attachment, and its mode of operation can be seen from Figs. 1 and 2. Fig. 1 shows the spray, spray chamber and sample beakers. The simple coaxial spray is made of Perspex and ebonite. The spray unit is connected to the burner unit by a poly(vinyl chloride) tube, this arrangement being adopted to permit the operator to remain at the spectrophotometer while he manipulates the samples. Fig. 2 shows a rear view of the burner unit with the cover removed to show the Meker-type burner. The spray is operated by compressed air at about 15 lb per sq. inch, and the burner burns ordinary town gas; consumptions are 17 litres of air and 5 litres of gas per minute. Light from the hollow-cathode lamp is collimated by the lens housed at the outer end of the burner casing. The parallel beam then traverses the flame and is focused on the entrance slit of the spectrophotometer by the lens at the inner end of the burner housing. This lens is arranged so that the flame is de-focused to minimise the effect of any flame emission.

#### METHOD OF OPERATION

After the lamp has been aligned and the wavelength-drum set for the appropriate line, the spectrophotometer is set to zero with the shutter closed. Distilled water is then sprayed into the flame, and the spectrophotometer is balanced on the "check" position, *i.e.*, the signal from the lamp is made to correspond to zero on the optical-density scale. A solution of the metal is then sprayed into the flame; this reduces the signal from the lamp, owing to absorption in the flame. The reduction in signal is conveniently expressed as an optical density, which can be read directly from the spectrophotometer. Optical-density determinations are made at various concentrations of the metal and a calibration graph is plotted, from which the

concentrations of sample solutions can readily be found. Table I shows the lamp current, the spectral line used and the optical densities corresponding to the introduction of different amounts of metals into the flame. Eleven determinations were made at each concentration, and Table I shows the mean of these, together with the standard deviations. Calibration graphs plotted from the results are shown in Fig. 3.

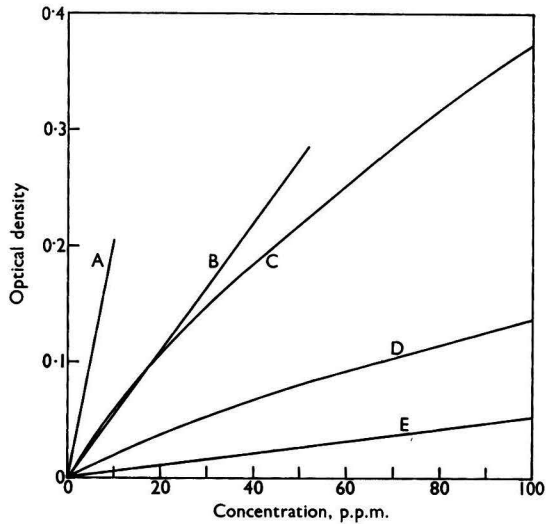

Fig. 3. Calibration graphs: curve A, silver; curve B, gold; curve C, palladium; curve D, rhodium; curve E, platinum

TABLE I

OPTICAL-DENSITY VALUES FOR SOLUTIONS OF SILVER, GOLD, PLATINUM, PALLADIUM AND RHODIUM

Each result is the mean of eleven determinations

Concentration, p.p.m.	Optical density of solution containing—				
	silver	gold	platinum	palladium	rhodium
0.1	0.002 ± 0.0008	—	—	—	—
0.5	0.010 ± 0.0007	—	—	—	—
1	0.020 ± 0.0007	0.005 ± 0.0007	—	—	—
2	0.041 ± 0.0007	0.011 ± 0.0007	—	0.012 ± 0.0007	0.004 ± 0.0007
3	0.061 ± 0.0009	0.015 ± 0.0008	—	—	—
4	0.082 ± 0.0011	0.022 ± 0.0015	—	—	—
5	0.103 ± 0.0008	0.027 ± 0.0012	—	0.030 ± 0.0008	0.011 ± 0.0008
6	0.123 ± 0.0010	0.034 ± 0.0011	—	—	—
7	0.144 ± 0.0011	0.039 ± 0.0009	—	—	—
8	0.164 ± 0.0010	0.045 ± 0.0012	—	—	—
9	0.184 ± 0.0015	0.050 ± 0.0009	—	—	—
10	0.205 ± 0.0011	0.056 ± 0.0015	0.004 ± 0.0012	0.053 ± 0.0008	0.020 ± 0.0011
20	—	0.110 ± 0.0005	—	0.101 ± 0.0011	0.040 ± 0.0012
25	—	—	0.013 ± 0.0010	—	0.046 ± 0.0009
30	—	0.165 ± 0.0005	—	0.143 ± 0.0008	—
40	—	0.220 ± 0.0005	—	0.184 ± 0.0012	—
50	—	0.274 ± 0.0000	0.027 ± 0.0009	0.218 ± 0.0015	0.080 ± 0.0012
60	—	—	—	0.253 ± 0.0014	—
80	—	—	—	0.316 ± 0.0024	—
90	—	—	—	0.343 ± 0.0005	—
100	—	—	0.100 ± 0.0012	0.374 ± 0.0014	0.139 ± 0.0003

Silver was determined at 3281 Å and a hollow-cathode current of 10 mA

Gold was determined at 2428 Å and a hollow-cathode current of 10 mA

Platinum was determined at 2659 Å and a hollow-cathode current of 36 mA

Palladium was determined at 2476 Å and a hollow-cathode current of 50 mA

Rhodium was determined at 3435 Å and a hollow-cathode current of 20 mA

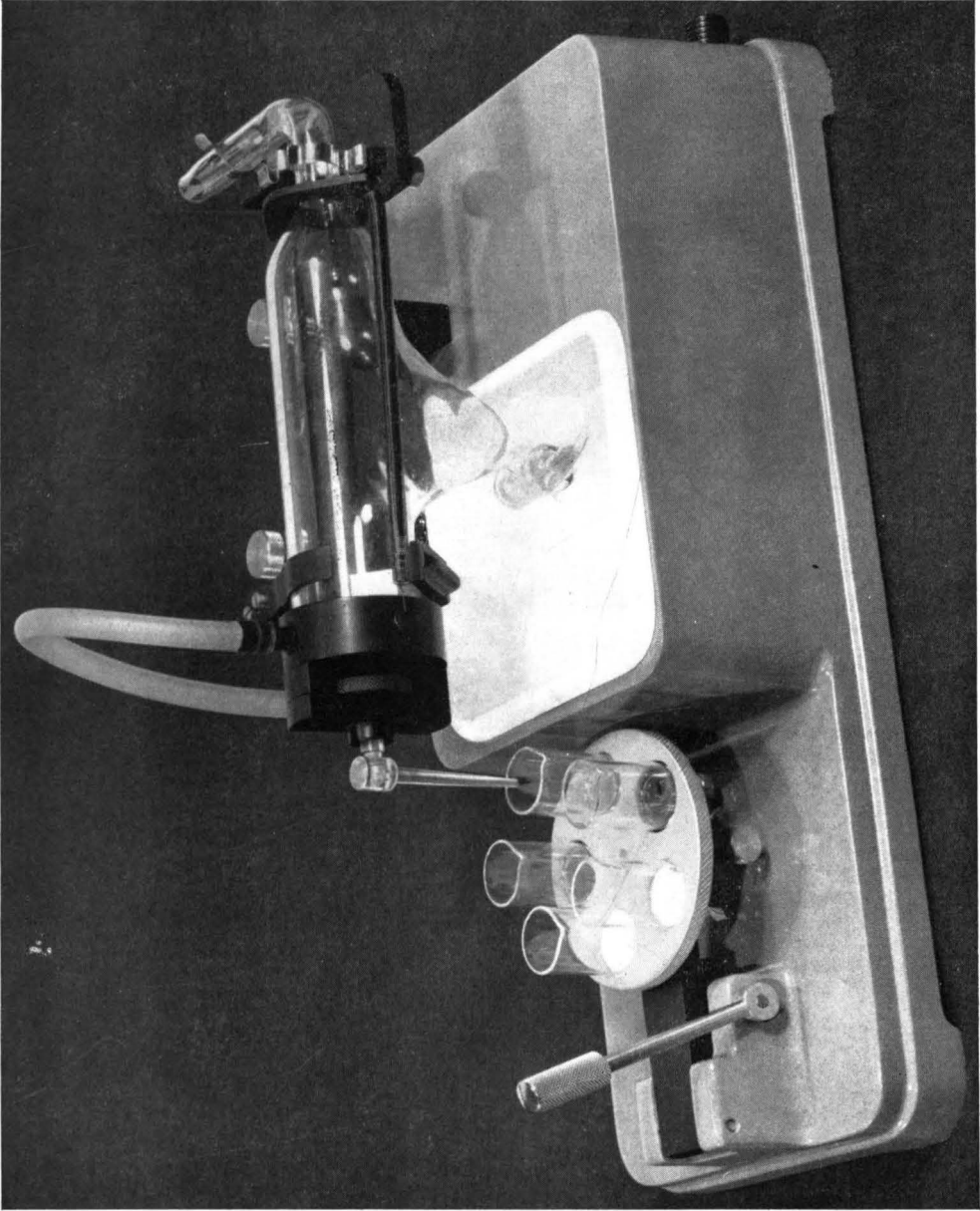

Fig. 1. Atomic-absorption attachment showing spray, spray chamber and sample beakers

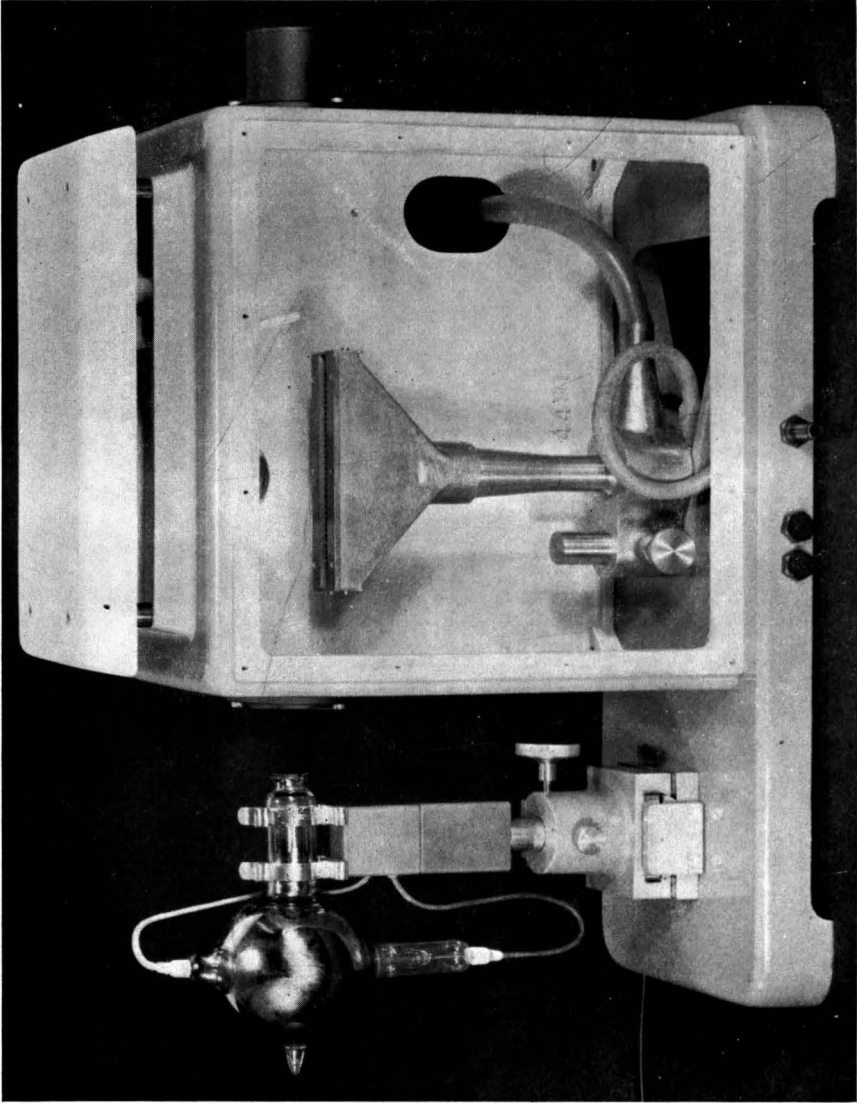

Fig. 2. Burner arrangement

## INTERFERENCE EFFECTS

Trials were made with each of the metals being studied in the presence of the others, an exception being made for silver, as solutions of the other metals contained chloride. However, the presence of a little suspended silver chloride did not affect the determinations of the other metals. In no instance was any interference detected. The effect of iron and lead was also examined, since comparatively large amounts of these elements would be present in determinations; no interference was found. With gold, care had to be taken to oxidise iron completely, or gold was lost by reduction to the metal; this loss was by no means instantaneous nor was it immediately obvious, as it was some time before a visible precipitate was formed. Another complication with gold, which at first caused difficulty in obtaining consistent results, was that, at a given concentration, the absorption decreased as the burner warmed up. When a water-jacket was fitted round the top of the burner, reproducibility became good. No such effect was observed with any of the other metals studied. In explanation of this effect, it is suggested that when the burner top became hot, the relatively unstable gold salts in the solution decomposed to form metallic gold before the solution entered the flame. The aggregates of gold so formed, although obviously extremely small, were not atomic and hence could not contribute to absorption.

## CONCLUSIONS

Atomic-absorption spectroscopy affords a convenient approach to the analysis of silver, gold and the platinum-group metals. Sensitivity is adequate, reproducibility is good and interferences are unlikely.

We thank Dr. A. Strasheim, National Physical Research Laboratory, Pretoria, for his suggestion that a new analytical method for these metals might be desirable, and Dr. A. C. Menzies, Controller of Research, Hilger and Watts Ltd., for his encouragement and for permission to publish this paper.

## REFERENCES

1. Walsh, A., *Spectrochim. Acta*, 1955, **7**, 108.
2. Menzies, A. C., "Colloquium Spectroscopicum Internationale VI, Amsterdam, 1956," Pergamon Press Ltd., London, 1957, p. 106.
3. Russell, B. J., Shelton, J. P., and Walsh, A., *Spectrochim. Acta*, 1957, **8**, 317.
4. Allan, J. E., *Analyst*, 1958, **83**, 466.

Received January 26th, 1959

## The Identification of Lucas 700 Headlamp-glass Fragments by their Physical Properties

By D. F. NELSON

(*The Dominion Laboratory, P.O. Box No. 562, Dunedin, New Zealand*)

Some physical properties of glass from fifty different Lucas 700 headlamps have been measured with a view to studying their usefulness in the identification of fragments in forensic work. The variations in colour and hardness are sufficient to permit classification into several groups. Comparative density observations permitted the greatest differentiation between samples, only two pairs of samples being indistinguishable. Each of the fifty specimens could be distinguished with certainty from the others.

The observed values for density and refractive index, together with variations in colour and hardness, are reported with brief statistical treatment. With the possible exception of density and refractive index in the small lower-density group, these four properties are independent of each other. Dispersion and fluorescence of the samples were found to be of no practical use. The results can be used to calculate the probabilities that two glasses from different headlamps would be indistinguishable in any particular instance.

THE value of the comparison of physical properties of glass fragments in the investigation of crime is well known.<sup>1,2</sup> Even when glass samples are of closely similar origin, *e.g.*, beer bottles,<sup>3</sup> the physical properties have been reported as being sufficiently varied to permit identification of individual samples in many instances. Modern headlamp glasses have been studied by Burd and Greene,<sup>4</sup> but their work was done with "sealed beam" headlamps, as used in the United States of America. Claims for probabilities that glass samples from different sources will be distinguishable<sup>5</sup> are based on comparative observations of a number of samples without reporting numerical values.

The present study arose during the investigation of a "hit-and-run" motor collision. It was necessary to determine whether the glass from one Lucas 700 headlamp could be distinguished from others of the same make. When investigating a motor accident, in order to determine whether broken glass came from a suspected person's car it is necessary to consider two questions, (*a*) what is the probability of getting differences as large as those observed from two samples of glass from the same headlamp, and (*b*) what degree of confidence is there that the two samples came from the same headlamp?

In order, therefore, to allow a mathematical treatment of these questions, and also for future use, individual determinations were made of density and refractive index, and values were assigned for colour and hardness. A knowledge of the way in which properties are distributed over the population at large, and also within individual headlamps, is useful (but not essential) for answering the first question and is essential for answering the second.

It was found that most modern British motor vehicles in New Zealand are fitted with Lucas 700 headlamps with the block pattern glass, *i.e.*, a 7-inch diameter headlamp glass with the word "Lucas" moulded in a circle in the middle of the glass and the words "700 Headlamp" embossed on the lower part of the glass.

### EXPERIMENTAL

Glass from fifty Lucas 700 headlamps was obtained from motor-repair depots in Dunedin between December, 1955, and October, 1956. In order to ascertain the variations within individual headlamps, six of the fifty glasses were sampled at centre, top, bottom, left side, and right side.

The density of each fragment was determined by flotation in bromoform diluted with xylene, which was chosen because its vapour pressure at 20° C is close to that of bromoform.<sup>6</sup> The volume used was 10 to 15 ml, contained in a stoppered cylinder and maintained at 20.0° ± 0.2° C in a water bath, xylene or bromoform being added dropwise until the glass fragment was suspended. The density of the flotation liquid was determined in a density bottle.

Comparative density tests were made with two chips of glass together in the immersion liquid. The density of the liquid was adjusted until one sample floated and the other sank.

When the difference in density was extremely small, the final adjustment of density was made by varying the temperature.

The refractive index of small chips was determined by observing the Becke line when the chips were immersed in liquids of known refractive index, usually mixtures of castor oil and clove oil. Observations were made in a room that was carefully adjusted to 20° C (20° ± 0.5° C), as a variation of 1° C altered the refractive index of the immersion liquids by 0.0004. In addition, selected samples were ground and polished, and their refractive indexes were measured with an Abbé refractometer at 20° C,  $\alpha$ -bromonaphthalene being used as the contact fluid and sodium light for illumination. The refractometer was calibrated by using a standardised glass slip ( $n_D = 1.5208$ ). Dispersion was measured at the same time by using white light and taking readings from the compensating drum of the refractometer.

Six arbitrary colour standards were selected from among the samples. These were assigned numbers from 11 to 16 and ranged in colour from very pale yellow through colourless to either pale blue or green. The remaining samples were then compared with the standards and placed in six corresponding colour groups. For these comparisons, fragments at least 1 cm square were used. If necessary, however, small fragments can be compared for colour under a low-power binocular microscope, but great care must be taken to compare chips of corresponding thickness.

Arbitrary standards of hardness were chosen from among the samples by determining their mutual scratching powers, as recommended by Tryhorn.<sup>2</sup> The fifty samples were then divided into six groups, which were numbered 1 to 6, group 6 being the hardest. The size of the fragments that can be used is limited by the ability of the operator to hold them for the scratching test.

The fluorescence of the samples in ultra-violet light was observed by using an Osram mercury-vapour lamp with a Woods-glass bulb (wavelength approximately 3000 to 4000 Å).

## RESULTS

The observed values for density, refractive index, colour and hardness are shown in Table I, in which the samples are arranged in ascending order of density.

Under the conditions used for determining density, the standard deviation for six replicate determinations was ±0.001 g per ml. It is estimated that the results are within ±0.002 g per ml of the true density.

In all instances when the determined densities differed by less than 0.004 g per ml, comparative density tests were carried out. In comparative density observations, it was found that a temperature rise of less than 0.2° C altered the density sufficiently to cause a floating glass chip to sink. It was also found that one immersion liquid varied in density from 2.5142 to 2.4996 g per ml when the temperature was raised from 17° to 23° C. Hence, a temperature change of 0.2° C causes a density change of 0.0005 g per ml. From this, it can also be calculated that a temperature rise of 1° C causes unit volume of the immersion liquid to increase by approximately  $10 \times 10^{-4}$ . The coefficient of cubical expansion of glass is approximately  $0.25 \times 10^{-4}$  (expressed as increase per unit volume per °C). The error caused by expansion of the glass sample can therefore be disregarded in this work.

When comparative density observations were carried out on five chips from different parts of the same headlamp, a temperature rise of less than 0.2° C was sufficient to cause all five chips just floating to sink. It was therefore apparent that density differences between chips from the same headlamp are within the limits of sensitivity of the method, *viz.*, 0.0005 g per ml.

It was estimated that refractive indexes determined by the immersion method would be within ±0.001 of the true values, and this was confirmed by the measurements made on selected samples by using the Abbé refractometer. The values measured with the refractometer were reproducible to ±0.0001.

The maximum variations in refractive index found in samples from different parts of the same headlamp was 0.0002. As the values were subject to a possible error of ±0.0001, this variation is at the limits of significance.

Eleven of the fifty samples were examined for dispersion ( $n_F - n_C$ ). As the values found ranged from  $0.0082 \pm 0.0003$  to  $0.0087 \pm 0.0003$ , it was evident that this property was of little use for differentiating between samples.

In the six tests when samples from different parts of the same headlamp were compared for colour, one sample was chosen and the remaining four were compared with it. In no instance was it possible to distinguish between them. As the six standards by which the whole population was divided into classes were distinguishable, the variation within an individual headlamp is less than the variation between the standards on either side.

Similarly, samples from different parts of individual headlamps were indistinguishable in hardness; the variation in hardness within individual headlamps is therefore less than the variation between the standards on either side.

When all fifty samples were examined under ultra-violet light only two (Nos. 38 and 48) could be readily distinguished from the remainder. As both these samples were at the blue or green end of the colour scale, the use of ultra-violet light did not carry the differentiation as far as visible light.

TABLE I  
PROPERTIES OF LUCAS 700 HEADLAMP-GLASS SAMPLES

Sample No.	Density at 20° C, g per ml	Refractive index at 20° C	Colour, group No.	Hardness, group No.
17	2.473	1.511	13	4
28	2.473	1.511	13	5
29	2.473	1.510	14	1
31	2.475	1.511	13	4
26	2.475	1.510	14	3
36	2.476	1.511	14	3
46	2.478	1.512	14	5
12	2.495	1.515	13	2
49	2.515	1.521	15	5
34	2.520	1.517	13	2
8	2.521	1.518	14	2
32	2.523	1.518	15	3
48	2.525	1.519	16	6
9	2.525	1.519	15	6
2	2.526	1.518	14	1
25	2.528	1.519	13	3
5	2.536	1.521	13	2
39	2.537	1.522	15	4
19	2.537	1.517	11	5
10	2.537	1.521	14	4
44	2.538	1.518	12	3
42	2.540	1.518	11	4
33	2.542	1.519	12	3
22	2.542	1.519	12	4
43	2.543	1.519	11	5
24	2.543	1.519	13	4
30	2.546	1.513	13	3
18	2.546	1.520	12	2
20	2.549	1.513	13	6
6	2.550	1.513	13	3
40	2.551	1.521	15	6
4	2.556	1.514	14	5
50	2.556	1.513	13	4
14	2.557	1.515	13	4
7	2.557	1.515	12	6
11	2.558	1.514	13	4
1	2.559	1.515	13	2
15	2.559	1.514	15	3
47	2.560	1.514	13	6
45	2.563	1.515	13	5
23	2.565	1.515	12	4
21	2.569	1.516	13	3
27	2.579	1.514	14	3
35	2.583	1.518	13	4
13	2.584	1.515	14	3
37	2.590	1.514	15	4
38	2.595	1.515	16	5
3	2.596	1.518	12	2
41	2.604	1.516	16	6
16	2.632	1.517	14	4



## DISCUSSION OF RESULTS

Although many of the samples have the same values of density or have values within the limits of experimental error, only two pairs (samples Nos. 28 and 29 and samples Nos. 7 and 14) were indistinguishable by observing comparative density. Samples Nos. 28 and 29, which were indistinguishable by density alone, were slightly but distinctly different in refractive index and different in hardness. Samples Nos. 7 and 14, although indistinguishable in refractive index, were distinctly different in both colour and hardness. In agreement with the observations of Marris,<sup>1</sup> it was found that density is a more useful property than refractive index for distinguishing between different glasses. This disagrees with the general observations of Gamble, Burd and Kirk<sup>7</sup> in their study of a large number of glasses from different sources.

The densities of the fifty samples studied show marked bimodal distribution, possibly owing to some change in the manufacturing process. Eighty-six per cent. of the samples appear to belong to one distribution (mean, 2.5520 g per ml; standard deviation,  $\pm 0.0266$  g per ml) combined with another group (mean, 2.4747 g per ml; standard deviation,  $\pm 0.0019$  g per ml), which forms 14 per cent. of the samples. Although the distribution of the larger group is slightly skew and slightly leptokurtic, it is probably sufficient not only to treat it as normal because the description, which is based on a relatively small sample, is obviously only approximate, but also to regard the whole population as a combination of this distribution and of a smaller group concentrated near 2.47 g per ml.

The distribution of the refractive index values is symmetrical and slightly platykurtic, but it can reasonably be treated as normal (mean, 1.5160; standard deviation,  $\pm 0.0032$ ).

Colour and hardness values were determined only on arbitrary scales and can be compared only with internal standards. Although the standards cannot be transferred, an indication is given of the degree to which other workers can divide the headlamp populations. An attempt was made to divide the ranges in a uniform manner. As the divisions into groups were at the limits of distinguishability, it is possible to move from the borderline of one group into the next group when colour and hardness are re-assessed. Two samples from the same source might be classified in adjacent groups if compared with the standards, but not if a direct comparison were made.

Colour distribution is substantially unimodal, being colourless at the centre and tapering to pale yellow at one side and bluish at the other, with one sample (No. 48—a distinct green) distinguishable from the remainder. The mean value of the group numbers assigned for colour (11 to 16) is 13.4 with a standard deviation of  $\pm 1.25$ .

The distribution for hardness appears to be unimodal (mean 3.8; standard deviation  $\pm 1.37$ ).

The numbers assigned for colour and hardness are such that, if treated as quantitative measures, the distributions can be regarded as normal.

If these various measurements are to be used together as evidence of identity, it is desirable to know whether they are interrelated. The values reported were plotted and examined on scatter diagrams. With the exception of a possible correlation between refractive index and density in the samples in the lower-density group, there seems to be no evidence of correlation between any pairs of properties. The samples in the lower-density group have lower refractive indexes than have the remainder of the samples and the spread of refractive-index values is low for this group. If this be true in general, then, if a headlamp belongs to this lower-density group, the extra evidence supplied by the refractive index is less useful than if the headlamp belongs to the higher-density group.

When it is desired to determine whether the glass found at the scene of an accident came from a broken headlamp of a suspected person's car, the first question to be considered is "What is the probability of getting differences as large as those observed from two samples of glass from the same headlamp?" Within individual Lucas 700 headlamps, variations of the properties studied were found to be too small to be detected by the methods used. If two samples of glass come from the same headlamp, differences in physical properties cannot normally be detected. With more refined methods, or possibly with certain particular headlamps, measurable differences might be observed from place to place within the headlamp. In such an instance, if several fragments of glass from each source are available, the question may be answered by means of well established statistical techniques such as Students T-test or randomisation tests.

If the glass samples from the two sources are indistinguishable, or if the probability mentioned in the first question is not small, then the hypothesis that both samples of glass came from the same headlamp is tenable. The second question then follows, "What degree of confidence is there that the two samples came from the same headlamp?"—*i.e.*, "What is the probability of getting equal or better agreement by chance?" This requires a knowledge of the distribution of properties over the population at large and also within individual headlamps.

Such knowledge of the Lucas 700 headlamp population is given here, and details of the calculations necessary to answer this question will be given elsewhere.

I thank Miss V. Z. Symonds for technical assistance in the later stages, Mr. O. H. Keys, Government Analyst, Dunedin, for advice and criticism, Dr. R. M. Williams, Director, Applied Mathematics Laboratory, New Zealand, for statistical guidance, and the Director, Dominion Laboratory, New Zealand, for permission to publish this paper.

#### REFERENCES

1. Marris, N. A., *Analyst*, 1934, **59**, 686.
2. Tryhorn, F. G., *Police J.*, 1939, **12**, 301; *J. Crim. Law & Criminol.*, 1939/1940, **30**, 404.
3. Kirk, P. L., and Roche, G. W., *J. Crim. Law & Criminol.*, 1947, **38**, 168.
4. Burd, D. Q., and Greene, R. S., *Ibid.*, 1949, **40**, 85.
5. Kirk, P. L., "Density and Refractive Index. Their Application in Criminal Identification," Charles C. Thomas, Springfield, Ill., 1951, p. 49.
6. Stull, D. R., *Ind. Eng. Chem.*, 1947, **39**, 517.
7. Gamble, Lucy, Burd, D. Q., and Kirk, P. L., *J. Crim. Law & Criminol.*, 1943, **33**, 416.

First received August 26th, 1957  
Amended, April 30th, 1958

## Notes

### A SYSTEMATIC SCHEME OF SEMI-MICRO QUALITATIVE ANALYSIS FOR ANIONIC SURFACE-ACTIVE AGENTS: AN ADDENDUM

IN our paper<sup>1</sup> on this subject nine special tests were referred to as being used several times in the systematic scheme. Only eight were in fact described; the ninth test, which is very similar to test 5, is as follows—

9. *Hydrolysis with syrupy phosphoric acid*—Place 5 mg of the active material at the bottom of a boiling tube, taking care that none adheres to the side of the tube. Add 0.2 ml of syrupy phosphoric acid, place the boiling tube in the heating block and heat for 10 minutes, maintaining the contents of the tube just below the boiling-point. Cool and, with the dropping-pipette, transfer the contents of the boiling tube to a semi-micro test-tube, dilute with an equal volume of water and neutralise to Congo red paper with 40 per cent. sodium hydroxide solution. Make alkaline to litmus with 15 per cent. sodium carbonate solution and extract three times with 0.5-ml portions of light petroleum - diethyl ether mixture (1 + 1). Combine the solvent extracts, wash three times with 50 per cent. ethanol and evaporate carefully to one-third of the initial volume. This is the ether extract used for the indicator test in Table V of the scheme. The extracted aqueous solution is retained for subsequent tests.

#### REFERENCE

1. Holness, H., and Stone, W. R., *Analyst*, 1957, **82**, 166.

CHEMICAL ENGINEERING DEPARTMENT  
MANCHESTER COLLEGE OF SCIENCE AND TECHNOLOGY  
MANCHESTER, 1

H. HOLNESS

POTTER & MOORE LTD.,  
LEYTON, LONDON, E.10

W. R. STONE  
Received March 23rd, 1959

## A COMPOSITE SPECTROPHOTOMETRIC METHOD FOR DETERMINING MOLYBDENUM, VANADIUM AND TITANIUM IN LOW-ALLOY STEELS

COMPOSITE procedures designed to improve the efficiency of the analysis of steels have been investigated in this laboratory, and an absorptiometric method for chromium and manganese has been reported.<sup>1</sup> Since for such purposes refinements are necessary in the application of absorptiometers, it has subsequently been decided that the use of simple and relatively inexpensive spectrophotometers is to be preferred. This Note describes the use of a Unicam SP600 spectrophotometer for the simultaneous determination of molybdenum, vanadium and titanium in low-alloy steels.

It is desirable, for simplicity, to use a reagent that reacts with all the elements under consideration, and the initial choice was between catechol<sup>2</sup> and hydrogen peroxide.<sup>3</sup> It was considered that a procedure involving catechol was unlikely to be simple, as the reagent has a colour, which must be considered in the mathematical evaluation, and also reacts with iron, manganese and aluminium. Hydrogen peroxide, on the other hand, is colourless and, of the commonly occurring alloying elements, only reacts with hexavalent chromium. It has been shown<sup>3,4</sup> that the coloured ions formed by molybdenum, vanadium and titanium with hydrogen peroxide are stable in the presence of each other, the total optical density of a solution containing all three ions being the arithmetical sum of the individual optical densities, provided that the individual solutions contain only molybdenum, vanadium or titanium and the reagents necessary for colour formation. It was considered that with little modification this procedure could be developed to fulfil our requirements.

### EXPERIMENTAL

By using solutions of ammonium molybdate, ammonium vanadate and potassium titanyle oxalate, Weissler's general conclusions<sup>3,4</sup> were confirmed. With the instrument available, measurements could not be made below 350 m $\mu$ , so that this wavelength was initially used in the determination of molybdenum, although the maximum absorption of this element is at a shorter wavelength; a small loss in sensitivity was therefore incurred. Since it was intended that the final procedure should be carried out by staff who are not highly skilled, it was considered desirable to avoid the use of perchloric acid if possible; the use of nitric acid as the necessary oxidising medium for colour formation was therefore investigated and found to be entirely satisfactory.

Measurements were then made on solutions containing ferric nitrate in addition to molybdenum, vanadium and titanium, a ferric nitrate solution of the same concentration as the test solution being used as blank. The absorption of the blank solution at shorter wavelengths was found to be so great that the spectrophotometer slit could not be opened sufficiently to permit a balance to be found, but this absorption was reduced by adding orthophosphoric acid, which allowed measurements to be made at 380 m $\mu$  and above. It was therefore necessary to determine molybdenum at 380 m $\mu$ , and all subsequent measurements were made at 380, 410 and 460 m $\mu$ .

Tests showed that changes in the concentrations of nitric and orthophosphoric acids had negligible effect on the absorptions of the three elements under consideration; this suggested a dissolution procedure that could be used for calibration purposes and for the samples under test.

### CALIBRATION PROCEDURE—

Three separate series of solutions were prepared to cover the ranges 0.3 to 1.5 per cent. of molybdenum, 0.25 to 1.0 per cent. of vanadium and 0.025 to 0.10 per cent. of titanium. Each solution contained 1 g of pure iron dissolved in 20 ml of nitric acid, sp.gr. 1.20, to which were added 3 ml of orthophosphoric acid, sp.gr. 1.74. The molybdenum series was prepared by adding 0, 3, 6, 9, 12 and 15-ml portions of a solution containing 1 mg of molybdenum per ml, and the vanadium and titanium series were prepared by adding 0, 2.5, 5, 7.5 and 10-ml portions of solutions containing 1 mg of vanadium or 0.1 mg of titanium per ml. Each solution was diluted to 50 ml, from which two 20-ml aliquots were withdrawn. To one aliquot was added 1 ml of 20-volume hydrogen peroxide, 1 ml of water being added to the other. The optical density of each solution was then measured against its corresponding blank in 1-cm cells at 380, 410 and 460 m $\mu$ . Optical density - concentration graphs were then plotted for each metal at each wavelength and the gradients of the corresponding nine linear equations were evaluated. From these were calculated the following relationships—

$$\text{Molybdenum concentration, \%} = 1.334 D_{460} - 2.872 D_{410} + 2.267 D_{380}$$

$$\text{Vanadium concentration, \%} = 1.800 D_{460} - 1.142 D_{410} + 0.246 D_{380}$$

$$\text{Titanium concentration, \%} = 0.908 D_{410} - 0.622 D_{460} - 0.208 D_{380}$$

where  $D_{380}$ ,  $D_{410}$  and  $D_{460}$  are the optical densities at 380, 410 and 460  $m\mu$  of a solution containing the three metals in the ranges tested.

#### INTERFERENCE—

Chromium appeared to be the only element likely to interfere, since, in the hexavalent state, it forms an intense blue colour with hydrogen peroxide. Although the peak absorption of this colour is not in the range 380 to 460  $m\mu$ , its absorption band is wide and there is considerable background absorption in this range. Since (a) the amount of chromium to be tolerated is high, *i.e.*, about 3 per cent. of the steel content, and (b) the compensating blank solution would not allow for the background effect and would lead to high readings, it is essential that chromium be reduced to a valency state in which it does not interfere. The proposed dissolution procedure maintains chromium in its lower oxidation state. In this condition it does not interfere, as was confirmed by measurements on a range of synthetic solutions containing different amounts of chromium.

It was considered that other elements present in the types of steel for which the method was intended would not interfere, an appreciation that was subsequently vindicated by the agreement between results obtained by the proposed procedure and the certified values of the samples analysed. Band-width restrictions cannot be quoted, since the spectrophotometer used was not fitted with any means of indication.

#### METHOD

##### PROCEDURE—

Dissolve 1 g of the steel sample in 20 ml of nitric acid, sp.gr. 1.20, and, when all reaction has ceased, add 3 ml of orthophosphoric acid, sp.gr. 1.74. Evaporate to a small volume, cool, and add 10 ml of nitric acid, sp.gr. 1.20, and 3 ml of orthophosphoric acid, sp.gr. 1.74. Repeat if necessary to dissolve the carbides. Add 20-volume hydrogen peroxide dropwise to reduce any manganese that may have been oxidised, and boil to destroy excess of the reagent. Filter through a Whatman No. 541 filter-paper to remove undissolved silica, cool the filtrate, and dilute to 50 ml. Withdraw two 20-ml aliquots. To one aliquot (the blank) add 1 ml of water, and to the other add 1 ml of 20-volume hydrogen peroxide. Measure the optical densities of the coloured solution against the blank in 1-cm cells at 460, 410 and 380  $m\mu$  with a suitable spectrophotometer. Determine the percentages of vanadium, titanium and molybdenum in the sample by one of the procedures described under "Evaluation."

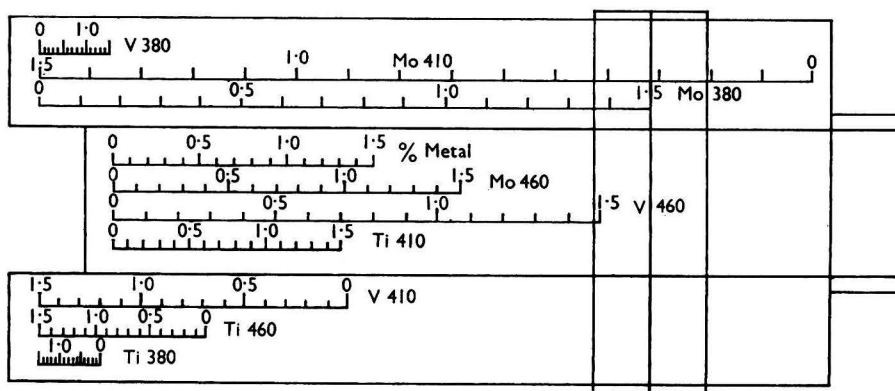

Fig. 1. Slide rule

#### EVALUATION

The percentages of molybdenum, titanium and vanadium may be calculated by direct substitution of the measured optical densities in the equations on p. 393. However, as this is a somewhat tiresome practice, two simplifications have been evolved and tested.

The first was simply the graphical representation of the nine terms relating optical density and the product of this and the appropriate constant included in the three equations. For example, for the product  $1.334 D_{460}$ , a line of gradient 1.334 was drawn, and, when any given optical density

at 460  $m\mu$  was read as abscissa, the corresponding ordinate was the required product. In this way, the arithmetic was reduced to simple addition and subtraction.

The second simplification was the construction of a slide rule, see Fig. 1, with which to perform the operations of addition and subtraction. The rule has a slide, a cursor and ten linear scales. Nine of these scales are graduated in optical-density units and have lengths proportional to the respective constants in the previously derived equations; the tenth scale gives the percentage of metal present.

## DISCUSSION OF RESULTS

Results by the proposed method on the British Chemical Standard range of low-alloy steels, to which additions of titanium had been made, are shown in Table I; reproducibility and accuracy are satisfactory for routine purposes in the ranges covered by the samples tested. The general level for the coefficient of variation is 3 per cent.

TABLE I  
RESULTS BY THE PROPOSED METHOD ON LOW-ALLOY STEELS

Sample	Molybdenum present, %	Vanadium present, %	Molybdenum found, %	Vanadium found, %	Titanium added, %	Titanium found, %		
B.C.S. No. 251	..	0.185	0.034	0.19	0.035	0.050	0.051	
				0.18	0.035		0.047	
				0.18	0.03		0.049	
				0.18	0.03		0.100	
				0.19	0.035		0.099	
				0.20	0.02		0.100	
				0.0	0.47		0.057	
				0.0	0.48		0.056	
				0.0	0.46		0.046	
				0.0	0.45		0.106	
B.C.S. No. 252	..	0.007	0.46	0.0	0.48	0.050	0.056	
				0.0	0.46		0.046	
				0.0	0.45		0.106	
				0.0	0.48		0.101	
				0.0	0.49		0.096	
				0.99	0.21		0.050	0.050
				0.99	0.22		0.046	
				0.92	0.21		0.047	
				0.97	0.22		0.108	
				0.98	0.21		0.101	
B.C.S. No. 253	..	0.94	0.22	0.95	0.22	0.100	0.099	
				1.20	0.53		0.058	
				1.31	0.52		0.048	
				1.26	0.52		0.051	
				1.29	0.52		0.104	
				1.27	0.53		0.101	
				1.32	0.53		0.096	
				1.45	0.26		0.046	
				1.46	0.27		0.048	
				1.47	0.26		0.047	
B.C.S. No. 254	..	1.29	0.52	1.48	0.27	0.050	0.095	
				1.47	0.26		0.094	
				1.40	0.27		0.104	
				0.55	0.35		0.052	
				0.53	0.34		0.051	
				0.55	0.33		0.053	
				0.54	0.34		0.103	
				0.55	0.34		0.102	
				0.53	0.35		0.099	
				0.30	0.09		0.049	
B.C.S. No. 255	..	1.41	0.26	0.31	0.09	0.050	0.053	
				0.33	0.10		0.055	
				0.30	0.09		0.104	
				0.32	0.10		0.104	
				0.32	0.10		0.095	
				0.39	0.64		0.051	
				0.45	0.66		0.051	
				0.39	0.63		0.052	
				0.43	0.65		0.100	
				0.40	0.62		0.092	
B.C.S. No. 256	..	0.53	0.36	0.41	0.64	0.100	0.098	

In general, the procedure is equally suitable for determining any one or two of the elements molybdenum, titanium and vanadium in the absence of the remainder.

The method is simple, and a single sample can be analysed in less than 30 minutes. It is not suggested that the procedure is suitable when the highest order of accuracy is required, since any error that exists or is incurred may clearly have a larger effect on the values of the results for a system in which optical-density differences are used than on a method in which only one element is determined.

We thank the drawing office of this establishment for preparing the slide rule, and the Admiralty for permission to publish this Note.

## REFERENCES

1. Curry, D. R., *Analyst*, 1958, **83**, 106.
2. Patrovský, V., *Chem. Listy.*, 1955, **49**, 854; *Chem. Abstr.*, 1955, 13018f.
3. Weissler, A., *Ind. Eng. Chem., Anal. Ed.*, 1945, **17**, 695.
4. —, *Ibid.*, 1945, **17**, 775.

BRAGG LABORATORY  
NAVAL ORDNANCE INSPECTION ESTABLISHMENT  
JANSON STREET, SHEFFIELD 9

M. FREEGARDE  
MISS B. JONES  
First received *March 20th*, 1958  
Amended, *December 22nd*, 1958

### THE SIMULTANEOUS SPECTROPHOTOMETRIC DETERMINATION OF ETHYL METHYL KETONE AND ETHYL ACETATE

It recently became necessary to determine the relative amounts of ethyl methyl ketone and ethyl acetate in a mixture of the two used as the solvent base for a liquid rubber. The conventional method of accomplishing this, after separation by distillation, is (a) to hydrolyse the ethyl acetate by heating under reflux with a known amount of sodium hydroxide solution, the excess of which is subsequently determined by titration with a standard acid, and (b) to form the oxime of the ketone by reaction with hydroxylamine hydrochloride, the equivalent amount of hydrochloric acid liberated in this reaction being titrated potentiometrically with standard alkali. As these procedures are somewhat time-consuming, it was decided to investigate the possibility of utilising the well known ultra-violet absorptions of the two liquids.

The extinction coefficients of both ethyl methyl ketone and ethyl acetate over a wide range of wavelengths are sufficiently high to prohibit spectrophotometric measurements of the pure liquids. It was therefore necessary to find a non-absorbing miscible liquid for dilution purposes. Of the several common organic liquids tried, *cyclohexane* was found to be suitable and was used to prepare mixtures of each of the two liquids under consideration. The optical densities of these mixtures were measured between 220 and 350  $m\mu$  with a Unicam SP500 spectrophotometer. Ethyl methyl ketone exhibited a maximum absorption at 280  $m\mu$  with a molecular extinction coefficient of 17.2 and ethyl acetate showed an absorption of extinction coefficient 49.1 at 220  $m\mu$ . The maximum absorption of ethyl acetate is several millimicrons below 220  $m\mu$ , but the absorption of *cyclohexane* in this region renders 220  $m\mu$  the shortest wavelength at which measurements are practicable. Ethyl acetate did not absorb at 280  $m\mu$ , and the molecular extinction coefficient of ethyl methyl ketone at 220  $m\mu$  was 0.82.

Measurements on solutions the concentrations of which separately covered the ranges 0 to 5 ml of ethyl methyl ketone per litre and 0 to 1.5 ml of ethyl acetate per litre showed that both solutions obeyed Beer's law in these ranges, which were chosen to cover an ethyl acetate concentration in the rubber solvent of 30 per cent. v/v or less. By measuring the optical densities of solutions containing ethyl methyl ketone and ethyl acetate in these ranges at 220 and 280  $m\mu$ , it was then shown that all optical-density values were additive for solutions containing mixtures of the two compounds. The values chosen were 0, 1, 2, 3, 4, and 5 ml of ethyl methyl ketone per litre and 0, 0.3, 0.6, 0.9, 1.2 and 1.5 ml of ethyl acetate per litre; a total of thirty-six solutions. The measurements can be summarised by the following expressions—

$$\text{Optical density at } 220 \text{ } m\mu \text{ (1-cm cell)} = 0.506 C_1 + 0.009 C_2 \quad \dots \dots (1)$$

$$\text{Optical density at } 280 \text{ } m\mu \text{ (1-cm cell)} = 0.191 C_2 \quad \dots \dots (2)$$

where  $C_1$  and  $C_2$  represent the concentrations of ethyl acetate and ethyl methyl ketone, respectively, in millilitres per litre. Upon this basis, the procedure described below was devised for the analysis of solvent mixtures containing 30 per cent. v/v or less of ethyl acetate.

## METHOD

## PROCEDURE—

By pipette, place a 2-ml aliquot of the distillate from the liquid rubber in a 20-ml calibrated flask, and dilute to the mark with *cyclohexane*. Mix thoroughly, and, by graduated pipette, transfer a 2.5-ml aliquot of the solution to a 50-ml calibrated flask. Dilute to the mark with *cyclohexane*. Mix thoroughly, and measure the optical densities of this solution in 1-cm quartz cells at 280 and 220  $m\mu$  with a suitable ultra-violet spectrophotometer. Use *cyclohexane* as blank. Relate the measurements to the concentrations of ethyl methyl ketone and ethyl acetate by comparison with calibration measurements made on solutions of the pure liquids.

## RESULTS

The proposed method was compared with the conventional chemical method, samples of the distillate from the liquid rubber under investigation being used. The spectrophotometric values were substituted in equations (1) and (2), and the results are shown in Table I. Agreement is satisfactory, the proposed method being characterised by a coefficient of variation of  $\pm 1$  per cent. or less. The samples for which the method was developed contained 30 per cent. or less of ethyl acetate, but it is considered that, should the necessity arise, this figure could be extended to 100 per cent. by making all measurements in cells of shorter light-path or by using more dilute solutions throughout, with a probable decrease in precision. The proposed method is considerably more rapid than the conventional method, since, after distillation of the liquid rubber sample, a combined determination can be completed in 5 minutes.

TABLE I  
COMPARISON OF RESULTS BY SPECTROPHOTOMETRIC AND CHEMICAL METHODS

Each result is the mean of five determinations

Solvent	Method of determination	Solvent found, %	Standard deviation, %
Ethyl acetate .. ..	Chemical	26.5	0.25
	Spectrophotometric	27.0	0.29
Ethyl methyl ketone .. ..	Chemical	72.2	1.12
	Spectrophotometric	73.3	0.44

This Note is published by permission of the Admiralty.

BRAGG LABORATORY  
NAVAL ORDNANCE INSPECTION ESTABLISHMENT  
JANSON STREET, SHEFFIELD 9

M. FREEGARDE  
MISS B. JONES  
Received January 5th, 1959

## Ministry of Agriculture, Fisheries and Food and Ministry of Health

### STATUTORY INSTRUMENTS\*

1959—No. 734. **The Ice-Cream (Heat Treatment, etc.) Regulations, 1959.** Price 3d.

*These Regulations, which came into operation on April 27th, 1959, consolidate and amend the Ice-Cream (Heat Treatment, etc.) Regulations, 1947 to 1952.*

1959—No. 831. **The Arsenic in Food Regulations, 1959.** Price 3d.

*These Regulations, which will come into operation on August 10th, 1959, lay down statutory limits for the arsenic content of foods and beverages.*

### CIRCULAR FSH 8/59\*

#### Milk and Dairies (General) Regulations, 1959

##### Approved Chemical Agents

*This Circular (price 4d.), dated May 1st, 1959, lists all the products approved by the Minister of Agriculture, Fisheries and Food and the Minister of Health for the cleansing of milk tankers, vessels or appliances as an alternative to scalding with boiling water or steam, in accordance with Regulation 27 (6) (a) of the Milk and Dairies (General) Regulations, 1959. Most have already been approved under the Milk and Dairies Regulations, 1949.*

\* Obtainable from H.M. Stationery Office. Italics indicate changed wording.

## Book Reviews

**GAS CHROMATOGRAPHY 1958.** Edited by D. H. DESTY. Pp. xiv + 383. London: Butterworths Scientific Publications; New York: Academic Press Inc. 1958. Price 70s.; \$12.00.

This book presents a readable account of the proceedings of the second symposium organised by the Gas Chromatography Discussion Group under the auspices of the Hydrocarbon Research Group of the Institute of Petroleum and the Koninklijke Nederlandse Chemische Vereniging held at the Royal Tropical Institute, Amsterdam, 19th to 23rd May, 1958. Almost all the papers in it were read at the Symposium, and the subject matter is divided, conveniently, into three separate sections.

The first section deals with the theory of gas chromatography. There are papers on the attainment of high column efficiencies and the use of columns containing wetted glass beads and of coated capillaries. The theoretical considerations on the separation of highly radioactive gases are dealt with, and further papers describe such subjects as sorption isotherms and sorption columns, diffusion processes in gas chromatography, symmetrical elution curves and the determination of activity coefficients by gas-liquid chromatographic procedures. The treatment in this section is often highly mathematical, but the non-mathematical reader need not be too perturbed. He will find that one of the most useful features of the book is the full description of the various discussions, and in reading these discussions he will note the reactions of many practically-minded men to the theoretical implications of the papers in this section.

The second section deals with new techniques and apparatus. It begins with a masterly survey by Dr. Martin on recent trends and developments. Flame ionisation, emissivity, hydrogen flame, argon, katharometer and thermal conductivity detectors are all described. There are useful papers dealing with the practical construction of high-efficiency columns, multiple columns and programmed column heating, base-line control and stationary phases. This section will be of great interest to all those analysts who are seeking to improve the efficiency of the columns they use and the sensitivity of the detectors they are concerned with.

The third section will have a strong appeal to all those analysts who are using gas chromatographic methods in their laboratories. The automatising of gas chromatography and automatic "preparative-scale" gas chromatography are described, and there are some interesting papers on such subjects as the analysis of essential oils, the separation of amino acid derivatives, the evaluation of sugars as stationary phases for the separation of phenols and the application of high-temperature work in the petroleum industry. Dr. A. T. James has contributed a useful summing up of the Symposium, and recommendations are made about the nomenclature and the presentation of gas-liquid chromatographic retention data.

Literature references are given at the end of each paper, and the presentation of this mass of data in such an excellent and readable form reflects great credit on the editor, D. H. Desty. All those analysts in whatever field who believe that gas-chromatographic procedures can help them in their work will find this book invaluable. They will realise in reading it that the theoretical considerations governing the choice and method of packing of their columns are of primary importance. They will probably feel the urge to insist that new and better detecting systems are developed. Moreover, in becoming acquainted with the many different types of analysis now carried out by gas-chromatographic tests they will, I feel sure, also become increasingly aware that this method in due course will become much more quantitative in character as new developments proceed. As a result of all this, many of the older methods of separation in current use will have to take second place. This book can be heartily recommended to "gas chromatographers" wherever they are.

J. HASLAM

**PRACTICAL CLINICAL BIOCHEMISTRY.** By HAROLD VARLEY, M.Sc., F.R.I.C. Second Edition. Pp. viii + 635. London: William Heinemann Medical Books Ltd. 1958. Price 42s.

The first edition of this book appeared in 1954. It was so far ahead of any other book on the same subject that it rapidly became a standard textbook and could be found in the library of almost every clinical laboratory. The new edition brings the book up to date, incorporating as it does the advances in methods of analysis and biochemical techniques that have subsequently occurred. It is fairly safe to say that practically any method that a chemist in a clinical laboratory will be called upon to perform has been described fully in this volume.

The first part of the book deals with some extremely practical details about the collection and keeping of biological specimens before analysis. Colorimetry and spectrophotometry are discussed in a cursory fashion, but the control of accuracy is given more prominence. The next 50 pages



deal with the biochemistry of diabetes. Various methods for blood glucose determinations are given, also glucose tolerance tests, the detection of sugar in urine and ketosis and its significance in diabetic coma. Blood and urine tests for kidney function and disease are fully described, and then come tests for gastric, liver and pancreatic function. The various inorganic substances and acid-base balance are next dealt with, and then oxygen capacity and haemoglobin determinations. Vitamins and hormones are also given place, and there are useful chapters on the examination of cerebrospinal fluid, milk, urinary stones and body pigments. Finally, there is a short chapter on drugs and poisons, and appendixes containing useful information on indicators, buffer solutions, etc.

The new matter in this volume is most helpful. The chapter on hormones has been completely re-written and contains the latest techniques for pregnandiol and oestrogens, and some hitherto unpublished work from the author's laboratory on the dihydroxyphenolic hormones. Methods for assessment of adrenocortical function are well described, including 17-ketogenic and 17-hydroxy-corticosteroids and the dihydroxyacetones. In the chapter on non-protein nitrogen are described the newer uricase method for uric acid, chromatography of amino acids, 5-hydroxyindoles (useful in diagnosis of metastasizing carcinoma) and serum transaminases. It is safe to assume that another edition will contain a chapter on enzyme analysis, a technique that will be increasingly used in the future. The chapter on plasma proteins has been much extended and gives an excellent description of electrophoretic technique. Several methods for cholesterol determination are given, including the recently popular method in which ferric chloride and sulphuric acid are used. (It is the reviewer's opinion that the time is ripe for much greater precision in the determination of cholesterol levels; the methods based on the various modifications of the Liebermann-Burchard reaction are no longer satisfactory.)

Many of the newer "function" tests are described, including methods for tubeless gastric analysis and the sweat test for fibrocystic disease of the pancreas and protein-bound iodine for thyroid functions. The section on drugs and poisons is useful for general purposes, but insufficiently detailed for forensic work.

The book shows a wealth of knowledge relating to clinical interpretation of results, is clearly set out and is well indexed. I am sure that its popularity will lead the author to start work immediately on the third edition of a subject expanding in geometrical progression.

R. F. MILTON

XV CONGRESSO INTERNACIONAL DE QUIMICA PURA E APLICADA (*Quimica Analitica*): Actas do Congresso (8 a 16 de Setembro de 1956). Volume I. Pp. 1028. Lisbon: General Secretary of the XVth International Congress of Pure and Applied Chemistry, Instituto Superior Technico. 1957. Price, together with volumes II and III, 320 Escudos.

This is the first of three volumes to be published of the Proceedings of the Lisbon Conference. It contains 111 communications of which 49 were delivered to the section on Microchemical Methods and 62 to that on Electrical Methods. Eighty-four papers do not appear to have been published elsewhere, of which nine appear in summary only. Inevitably the quality of the communications is variable, but the volume contains many useful contributions to analytical chemistry. A full list of contents is published in *Analytical Abstracts* (1959, 6, 1175).

The publication has been delayed owing to the tragic death in a motor accident of the Secretary-General of the Congress, Eng. L. de M. Acciaiuoli.

NORMAN EVERS

SYMPOSIUM ON SPECTROCHEMICAL ANALYSIS FOR TRACE ELEMENTS. Papers presented at the Sixtieth Annual Meeting of the American Society for Testing Materials, Atlantic City, N.J., June 18th, 1957. Pp. vi + 79. Philadelphia, Pa.: American Society for Testing Materials. 1958. Price \$2.75.

Much of the early spectrochemical work on the determination of elements at trace levels was carried out on samples of an agricultural, geological or biological nature. Recent developments have extended interest in contents around the part per million level to other fields, including semi-conductors and atomic energy. In consequence, the complexity of the samples to be examined has increased, and no one method can be expected to cover all elements or all materials. The papers reprinted in this publication were presented at a Symposium of the 1957 Annual Meeting of the American Society for Testing Materials and deal with some specialised methods for specific problems, rather than discussing the wider aspects of the subject.

The first contribution, by V. A. Fassel, W. A. Gordon and R. W. Tabeing, describes the determination by emission methods of oxygen in metals, down to 20 p.p.m. in steel and to a somewhat higher level in titanium and lanthanum. Excitation is by direct-current arc discharge in an atmosphere of argon. The paper by J. A. Norris reviews the field of trace-element determination

in metals, taking 100 p.p.m. as the upper limit for trace elements in metals. Tables are presented showing the limits of direct determination of many trace elements in different metallic bases. There is also a brief discussion of various methods of chemical separation and concentration. Both contributions deal with applications to atomic-energy problems.

J. M. Morris and F. X. Pink deal with the determination of trace elements in germanium and silicon, discussing the methods of separation required to remove the major constituents before excitation in a graphite spark source. In semi-conductors, interest in such elements as boron, aluminium, phosphorus, antimony and arsenic extends to the parts per thousand million level and analytical curves, with molybdenum as internal standard, are shown for these elements.

From the Harvard Medical School, B. L. Vallee reports good results from methods with porous-cup excitation. He presents results from various fractions of livers and other biological materials, discussing the significance of the distribution in the study of enzyme activity. Some methods applicable to soils and plants are described by W. G. Schrenk of the Kansas Agricultural Experiment Station, and K. J. Murata of the U.S. Geological Survey deals with trace elements in geological materials. In both instances, direct-current arc excitation is preferred, prior chemical concentration often being necessary to obtain the required sensitivity.

The papers in this symposium are variable in approach, originality and amount of spectrochemical detail presented; this detracts somewhat from the value of the publication, which is rather expensive for its size. One wonders whether it would not be better if such papers were made available through the normal channels of journal publication. R. L. MITCHELL

### Publications Received

- COLORIMETRIC METHODS OF ANALYSIS: INCLUDING PHOTOMETRIC METHODS.** Volume IIA. By FOSTER DEE SNELL, Ph.D., and CORNELIA T. SNELL, Ph.D. Pp. x + 793. Princeton, N.J., New York, Toronto and London: D. Van Nostrand Co. Inc. 1959. Price \$15.00; 112s. 6d.
- CHROMATOGRAPHIC REVIEWS: PROGRESS IN CHROMATOGRAPHY, ELECTROPHORESIS AND RELATED METHODS.** Volume I. Edited by MICHAEL LEDERER. Pp. x + 276. Amsterdam, New York and Princeton: Elsevier Publishing Co.; London: D. Van Nostrand Co. Ltd. 1959. Price 45s.
- INDEX OF CHEMISTRY FILMS: A COMPREHENSIVE LIST OF FILMS AND FILMSTRIPS ON CHEMISTRY AND RELATED TOPICS.** Pp. x + 150. London: The Royal Institute of Chemistry. 1959. Price 5s.
- THE SEQUESTRATION OF METALS: THEORETICAL CONSIDERATIONS AND PRACTICAL APPLICATIONS.** By ROBERT L. SMITH, B.Sc., Ph.D., R.R.I.C. Pp. viii + 256. London: Chapman & Hall Ltd. 1959. Price 42s.
- PRINCIPLES OF ELECTROLYSIS.** By C. W. DAVIES, D.Sc., F.R.I.C. Pp. vi + 30. London: The Royal Institute of Chemistry. 1959. Price 3s. 6d.  
*Monographs for Teachers No. 1.*
- PRINCIPLES OF OXIDATION AND REDUCTION.** By A. G. SHARPE, M.A., Ph.D., F.R.I.C. Pp. vi + 30. London: The Royal Institute of Chemistry. 1959. Price 3s. 6d.  
*Monographs for Teachers No. 2.*
- INFESTATION CONTROL: A SERVICE TO AGRICULTURE AND FOOD STORAGE.** Issued by The Ministry of Agriculture, Fisheries and Food. Pp. iv + 32. London: Her Majesty's Stationery Office. 1958. Price 4s.
- NOTES DU SERVICE DE GÉOLOGIE ET DE PROSPECTION MINIÈRE: ANALYSE DES EAUX. MÉTHODE UTILISÉE AU LABORATOIRE DE CHIMIE DU SERVICE DE GÉOLOGIE ET DE PROSPECTION MINIÈRE DE L'A.O.F.** By B. MARTINET, Ing. chim. Pp. 26. Dakar, French East Africa: Haut Commissariat de la République en A.O.F.
- PAINT TRADE MANUAL OF RAW MATERIALS AND PLANT.** Compiled by H. W. CHATFIELD, Ph.D., B.Sc., F.R.I.C., M.I.Chem.E. Third Edition. Pp. xii + 380. London: Scott Greenwood & Son Ltd. 1959. Price 30s.
- QUANTITATIVE METHODS IN HUMAN PHARMACOLOGY AND THERAPEUTICS.** Volume 3. Edited by D. R. LAURENCE, M.D. Pp. xviii + 254. London, New York, Paris and Los Angeles: Pergamon Press Ltd. 1959. Price 45s.  
*Proceedings of a Symposium held in London on 24th and 25th March, 1958.*
- PROGRESS IN BIOCHEMISTRY: A REPORT ON BIOCHEMICAL PROBLEMS AND ON BIOCHEMICAL RESEARCH SINCE 1949.** By FELIX HAUROWITZ, M.D., Dr.rer.nat. Pp. xii + 358. Basle, Switzerland: S. Karger; New York and London: Interscience Publishers Ltd. 1959. Price \$8.50; 60s.

**CLASSIFIED ADVERTISEMENTS**

*The rate for classified advertisements is 5s. a line (or space equivalent of a line), with an extra charge of 1s. for the use of a Box Number. Semi-displayed classified advertisements are 60s. per single-column inch.*

**ANALYST** back volumes and sets wanted to buy for cash, Also other scientific journals. Write to A. Ashley, 27, East 21 Street, New York, 10, N.Y., U.S.A.

**BRITISH TITAN PRODUCTS COMPANY LIMITED**

has vacancies for

**CHEMISTS**

in its Research Laboratories at  
Billingham, Co. Durham.

The Company is primarily concerned with the large scale manufacture of Titanium Dioxide and is characterised by a considerable expansion in post-war years. This continuing development is associated with a multiplicity of physical and inorganic chemical problems which can provide an interesting and worthwhile job in well equipped laboratories and pilot plants.

Applications are invited from Graduates with good honours degrees for the above vacancies. Some industrial experience is desirable, but not essential. Salaries and prospects are very attractive for men with the right qualities: conditions of work are good: a Staff Bonus, Superannuation Scheme and Non-contributory Life Assurance are in operation: housing assistance is available if required.

Applications will be treated in the strictest confidence and should be addressed to the Personnel Manager, British Titan Products Company Limited, Billingham, Co. Durham, quoting Reference S.1.

**EXPERT IN PHYSICAL TESTS METHODS**

**THE** Research Division of a Group of Companies in the textile, adhesives and rubber and plastics fields wish to appoint a fully qualified man to a position in their Standards Division. Experience in physical testing rather than in the mentioned fields is to be preferred and the position is suited to a chemist with a physical approach to technical problems. 2nd Class Honours or the equivalent professional qualification in chemistry, plastics or rubber are essential. Applicants should be under 30 years of age. The salary paid will be according to qualifications and experience and is in line with the more generous scales in industry. Holidays and working hours are in conformity with modern practice and a generous pension scheme is in operation. The Laboratories are situated in a country district 25 miles north of London. Write, giving details of age, qualifications, previous experience and salary required to: Research Manager (Administration), Smith and Nephew Research Ltd., Hunsdon Laboratories, Nr. Ware, Herts.

**ANALYST**

AN EXPERIENCED  
**CHEMIST**

with A.R.I.C. or equivalent qualifications is required to undertake advanced analytical work on oils, fats, soap products and detergents for a Works Laboratory in Manchester.

Applicants who should desirably have experience in this field should write giving full details of age, education, qualifications and experience to Box No. 3988, The Analyst, 47 Gresham Street, London, E.C.2.

Replies to be received not later than 25th June, 1959.

**MICRO-ANALYST** required to take charge of a laboratory performing elemental analysis of organic compounds at Chesterford Park Research Station, near Saffron Walden, Essex. Sound knowledge of general techniques and practical experience essential. Five day week. Good canteen facilities. Lodging accommodation arrangeable. Full particulars and salary expected to Personnel Manager, Fisons Pest Control Limited, Harston, Cambridge, quoting Reference No. 1483.

**THE DISTILLERS COMPANY LIMITED****SENIOR ANALYST**

The Company has a vacancy for an experienced analytical chemist in the Works Laboratories at the Hull, Yorkshire, factory of the Chemical Division, where a wide range of organic chemicals is manufactured in bulk.

Candidates, aged 30-40, must hold an honours degree in Chemistry, or an equivalent qualification, and have experience of analytical work in industry and of control of staff. The successful candidate will directly supervise a team of technical assistants engaged on analytical control of manufacturing processes, and will be responsible for the improvement of methods, the preparation of reports and the maintenance of records. He will be responsible to the Chief Works Chemist and will work in a large modern, well equipped laboratory.

Write:

STAFF MANAGER,  
THE DISTILLERS COMPANY LIMITED,

21, ST. JAMES'S SQUARE,  
LONDON, S.W.1.

Quote Ref. 50/59.A.

**ASSISTANT ANALYST**

required in the Analytical Section at  
**Woodstock Research Centre**

near

**Sittingbourne, Kent**

Applicants of Higher National Certificate Standard preferably in the age range 18-25, should have had experience in one or more of the following fields:—organic micro-analysis, general organic analysis, analysis of agricultural technical products and formulations, determination of toxicant residues in crop or animal products. Five day week, canteen facilities and excellent pension scheme.

Please write giving full details of age, experience and qualifications to:—

"SHELL" RESEARCH LIMITED,  
PERSONNEL RECRUITMENT W.,  
16, FINSBURY CIRCUS,  
LONDON, E.C.2.

TWO

**LABORATORY  
ASSISTANTS**

with National Certificate in Chemistry are required for Works Laboratory in the Manchester area for duties in soapmaking and oils and fats chemistry

Applications, stating age, education, qualifications and experience, should be addressed to Box No. 3989, The Analyst, 47, Gresham Street, London, E.C.2, to be received not later than 25th June.

**LAPORTE CHEMICALS  
LIMITED**

require the following

**ANALYTICAL CHEMISTS**

for their Analytical Research Laboratories  
at LUTON, Beds.:-

(1) A CHEMIST or PHYSICIST to take charge, under the Chief Analyst, of work using radio-chemical techniques and of work on X-ray diffraction.

Candidates should have a good honours degree in chemistry or physics or possess an equivalent qualification. They should have had several years experience in either radioactive tracer or X-ray diffraction work.

(2) ANALYTICAL CHEMISTS to work on the development of new methods and on the application of new analytical techniques, including automation.

Candidates should have a degree in chemistry or an equivalent qualification. Some experience would be an advantage.

The work is of a non-routine nature and is concerned with the development of analytical methods for the Company's processes and products. The laboratory facilities are excellent and include the latest physical instruments. There is adequate scope for advancement.

Replies giving details of age, qualifications and experience and quoting Ref: LCL/A1/44 should be addressed to Laporte Group Personnel Manager, Hanover House, 14 Hanover Square, W.1.

**A** YOUNG and vigorous organic chemical company with strong international connections wishes to fill the additional technical post of Senior Analytical Chemist. Applicants aged preferably 27-35 years, graduate in chemistry, with 5-10 years experience of organic chemical control work, analytical methods on research. Administrative ability an advantage. Excellent prospects for a dedicated enthusiast. Good salary. Pension and Life Assurance Schemes. Reply in complete confidence stating age, present position and salary to Box No. 3987, The Analyst, 47 Gresham Street, London, E.C.2.

**BORAX CONSOLIDATED LIMITED**

require a

**SENIOR ANALYTICAL  
CHEMIST**

for their Research Centre and Laboratories situated in Chessington, Surrey.

Applicants must be chemistry graduates (or A.R.I.C. by examination) and have had several years' varied experience of practical inorganic and organic analysis. Experience in microchemistry is desirable. The Chemist (male) appointed will be required to take charge of an established Section whose main function is to provide an analytical service for the Research Department. The work is of a non-routine nature, and duties will include development of new methods. Applicants must have had experience in a similar appointment, and be good organisers and able to control staff.

The salary paid will be commensurate with experience and the responsibility involved. A non-contributory pension scheme is operated. Five-day week.

Applications should in the first instance be addressed to Staff Manager, Borax Consolidated Limited, Carlisle Place, S.W.1.

COMMONWEALTH OF AUSTRALIA  
AUSTRALIAN ATOMIC ENERGY COMMISSION  
ANALYTICAL RESEARCH CHEMIST—A61416-2006  
AUSTRALIAN ATOMIC ENERGY COMMISSION  
RESEARCH ESTABLISHMENT,  
LUCAS HEIGHTS, SYDNEY, AUSTRALIA

An excellent opening presents itself to a GRADUATE in CHEMISTRY interested in a wide range of analytical chemistry problems relating to atomic energy. A full range of the latest instrumentation is available in modern chemical laboratories. The successful appointee will be required to supervise a staff of approximately 14 within the Analytical Chemistry Group. Total staff of the Research Establishment is at present about 450 and further rapid expansion is under way. Applicants should have had at least 8-10 years post-graduate experience.

Further information may be obtained from: Chief Scientist, A.A.E.C. Research Establishment, Private Mail Bag, Sutherland, New South Wales, Australia, or A.A.E.C. Liaison Officer, Australia House, Strand, London, W.C.2.

**R**USTON & HORNSBY LIMITED, LINCOLN, have a vacancy for SENIOR ANALYST in the analytical section of the central metallurgical laboratories of this large engineering works. Applicants must have experience in the latest techniques of analysis for the wide range of materials encountered in an engineering works, including ferrous and non-ferrous metals, solid liquid and gaseous fuels, and of ashes and deposits, etc. Salary according to qualifications and experience. Membership of a generous pension scheme. Applications from suitable qualified persons, with age and outline of previous experience, should be forwarded to The Manager, Industrial Relations Department.

**M**ICROANALYST. Fully qualified microanalyst (Ph.D.) with eight years experience of supervision and organisation of analytical methods and research, available immediately, preferably Southern England. Prepared to equip and run new microanalytical laboratories, or to supervise microanalytical department. Reply to Box 3990, The Analyst, 47, Gresham Street, London, E.C.2.

**O**LD established analytical and consulting practice for sale. Address Box No. 3991, The Analyst, 47 Gresham Street, London, E.C.2.

**A**NALYST with industrial experience in drugs or fine-chemicals required for Consulting Laboratory in London. Progressive post for man under 30. Salary £1000 p.a. Five-day week. Applications with full details to Box 3992, The Analyst, 47, Gresham Street, London, E.C.2.

**BINDING**

Have your back numbers  
of The Analyst bound in  
the standard binding case

Send the parts together  
with a remittance for 12/6

to:

**W. Heffer & Sons Ltd**  
**Hills Road Cambridge**

# it's MONROE again...

Once again Monroe strides ahead in the race to provide business with high-efficiency low-cost mechanised figuring. Latest addition to the comprehensive Monroe range, the LN-163 is the only hand-operated calculator that gives you "tens carry" and "0 series" dials. As a first step towards mechanising your figuring work . . . as an invaluable auxiliary to your present equipment . . . the super-efficient, full keyboard, Monroe LN-163 is a machine well worth investigating.

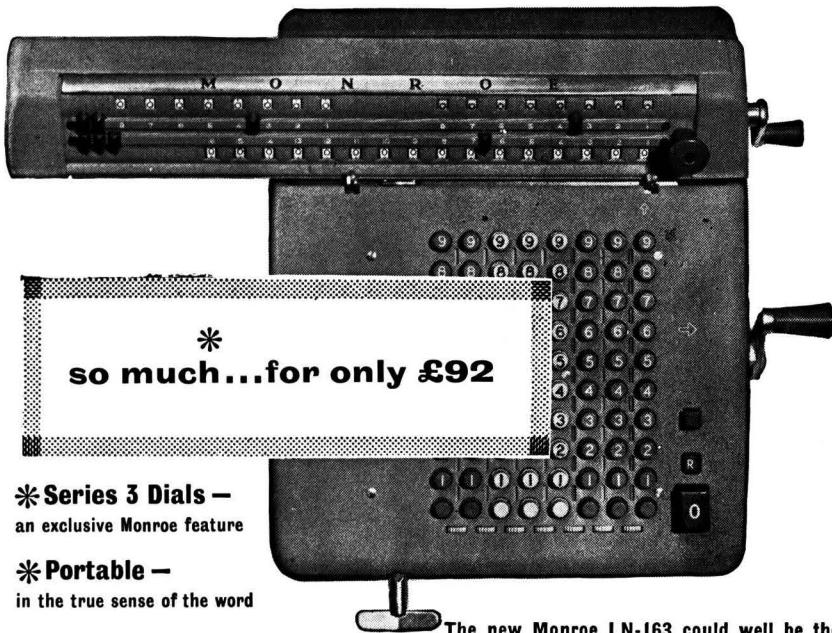

**\* Series 3 Dials —**  
an exclusive Monroe feature

**\* Portable —**  
in the true sense of the word

**\* Full Keyboard —**  
with all its attendant advantages

**\* Direct Alignment —**  
keyboard columns and carriage dials

**\* Ease of Operation —**  
fatigue-free, wrist-only action

**\* Silence —**  
the quietest machine ever made

The new Monroe LN-163 could well be the solution of your figuring problems. Ask your local Monroe Branch for a personal demonstration — or write for further details to:—

**MONROE**

MONROE CALCULATING MACHINE COMPANY LIMITED, Bush House, Aldwych,  
London, W.C.2 COVent Garden 0211

CF 4  
DOUBLE-BEAM  
RATIO RECORDING  
U.V. GRATING  
SPECTROPHOTOMETER  
1850—10,000 Å

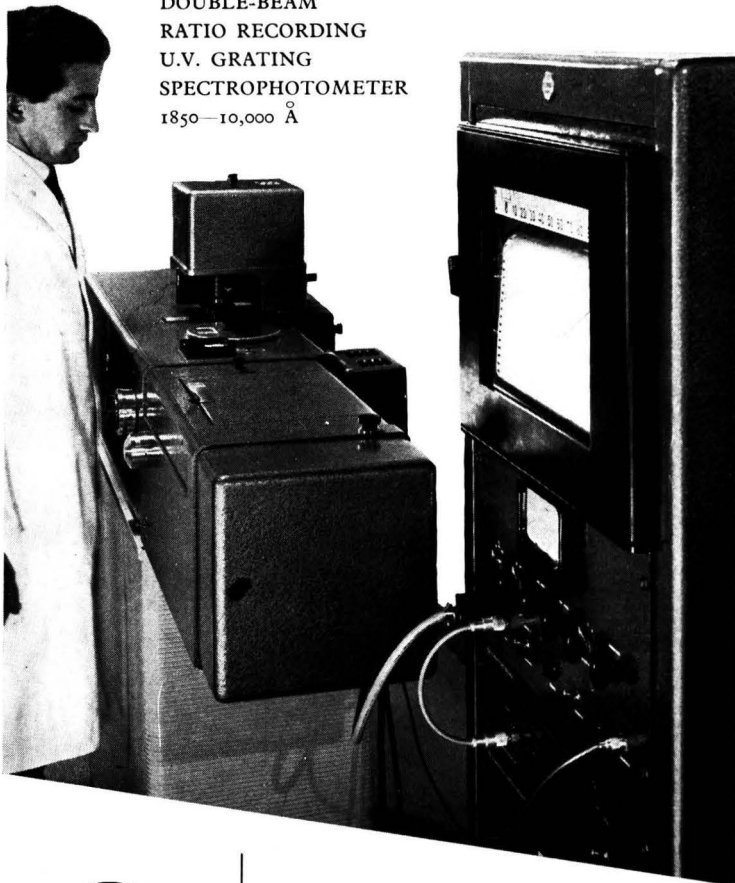

ATTACHMENTS ARE  
AVAILABLE FOR RAPID  
CHANGEVER TO

- Spectrofluorimetry
- Flame Spectroscopy
- Turbidity Measurements
- Fluorescence Measurements
- Reflection Measurements
- Total Light Reflection  
Measurements (Ulbrich Sphere)
- Heated and Flow-Through  
cells are available.
- Standard absorption paths up  
to 40 mm. may be increased  
up to 1 metre by an attachment.

**Note these outstanding features**

**CONSTANT BANDWIDTH** over the whole working range, because of the perfectly linear dispersion of the grating monochromator. No slit adjustments are required during recording. Bandwidths of 1-2 Å are possible.

**UNIFORM RESOLUTION** over the entire ultraviolet, visible and near infrared spectrum.

**COMPLETE FREEDOM FROM STRAY LIGHT** enables precision measurements to be made down to 1870 Å.

**ELECTRICAL COMMUTATION** of the Photomultiplier signals prevents errors in the measuring circuit and is maintenance-free.

**TRUE DOUBLE-BEAM SYSTEM** of the flicker type ensures complete stability and accuracy.

**AUTOMATIC ENERGY COMPENSATION** controls and levels differences in spectral energy emission of the source and spectral sensitivity of the photomultiplier.

**NO BATTERIES**, all mains-operated.

**ALSO AVAILABLE AS A VERY-HIGH PRECISION SINGLE BEAM NON-RECORDING INSTRUMENT. PHOTOMETRIC ACCURACY 0.15%**

Write for illustrated bulletin No. 56/6 to

**OPTICA UNITED KINGDOM LIMITED**  
A7 Factory, Princes Way Team Valley Trading Estate  
GATESHEAD-ON-Tyne, 11.



## GREEN'S PURE FILTER PAPERS

are

Competitive in Price and  
made to published standards.

Ask for free descriptive book  
MG. 59 which gives you the  
specification.

**J. BARCHAM GREEN LTD**  
Maidstone                      England



## 'AGLA'

### MICROMETER SYRINGE

A precision instrument  
for use as a burette or  
syringe, and capable of  
measuring very small  
volumes of fluid with an  
accuracy of 0.00005 ml.



**BURROUGHS WELLCOME & CO.**  
(THE WELLCOME FOUNDATION LTD.) LONDON

## NILOX

### LABORATORY GAS SCRUBBER

The new 'Electrochemical Laboratories'  
gas purification system has the following  
advantages:—

- O<sub>2</sub>-free gas stream on tap.
- Uses plain commercial N<sub>2</sub>, H<sub>2</sub>, A.
- Acidic and basic impurities removed.
- Stream can be left on overnight.
- Saves cost of high purity cylinders.
- Initial and running costs low.

Typical analysis:—

- |  |                         |
|--|-------------------------|
| (1) Plain commercial N <sub>2</sub>                      | 2000 ppm O <sub>2</sub> |
| (2) High purity commercial N <sub>2</sub> . . . . .      | 10 ..                   |
| (3) 'NILOX' — purified N <sub>2</sub> from (1) . . . . . | 0.2 ..                  |

*Details on request.*

### ELECTROCHEMICAL LABORATORIES

5, HIGHFIELD, WARDLE ROAD,  
SALE, MANCHESTER

Tel.: Sale 6529

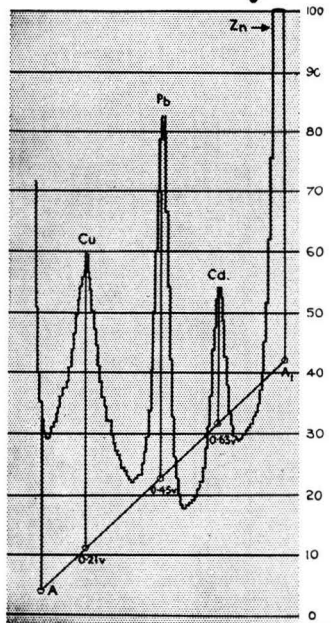
\* **COPPER · LEAD · CADMIUM....with ZINC***How long would it take to analyse*

by CONVENTIONAL METHODS, a solution having the following metals present —

COPPER - - - 3 p.p.m.                      CADMIUM - 2 p.p.m.  
LEAD - - - 7 p.p.m.                         ZINC - 200,000 p.p.m. ?

These Square Wave Polarograms recorded by the

## MERVYN-HARWELL SQUARE WAVE POLAROGRAPH Mk. III

are reproduced here to show the identification of these metals, in these proportions, in solution. Note the high ratio of Zn to Cd., without interference. The peaks are identified by the automatic potential markers AA1, which enable half-wave potentials to be accurately established. Permanently recorded on a 10" wide chart.

\* This was an actual problem presented to Mervyn Instruments by a leading chemical manufacturing organisation.

Speediest, most Accurate, the Fundamental Development in Analysis — and therefore the most Economic. Convenient in Design, Sensitive in Application.

Send for our full technical leaflets, quoting "Analyst" to

**MERVYN INSTRUMENTS**

COPSE ROAD, ST. JOHN'S, WOKING, SURREY.

Telephone: Woking 5200.

FBI8c

## THE LABORATORY GLASSBLOWERS COMPANY

COMPLETE LABORATORY FURNISHERS

PRESENTS:—

### THE WATSON MARLOW AIR FLOW INDUCER

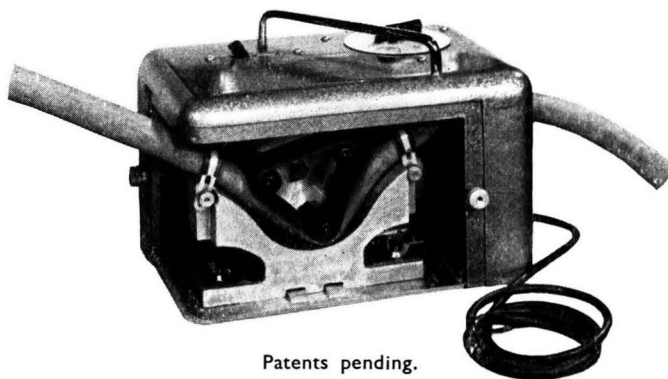

Patents pending.

The Fluid, any fluid, flows through the pipe and nothing else.

FULL PARTICULARS AND PRICE ON APPLICATION.

**THE LABORATORY GLASSBLOWERS CO., VALLEY WORKS,  
LANE END ROAD, SANDS, HIGH WYCOMBE, BUCKS.**

TELEPHONE HIGH WYCOMBE 2419



# The world's most extensive range of MASS SPECTROMETERS

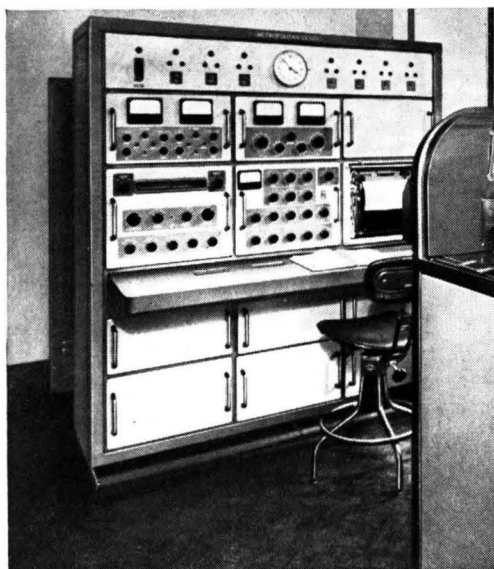

Designed to exploit fully the very latest analytical techniques, these Mass Spectrometers produced by Metropolitan-Vickers Electrical Co. Ltd. represent the most comprehensive range of instruments offered by any company in the world.

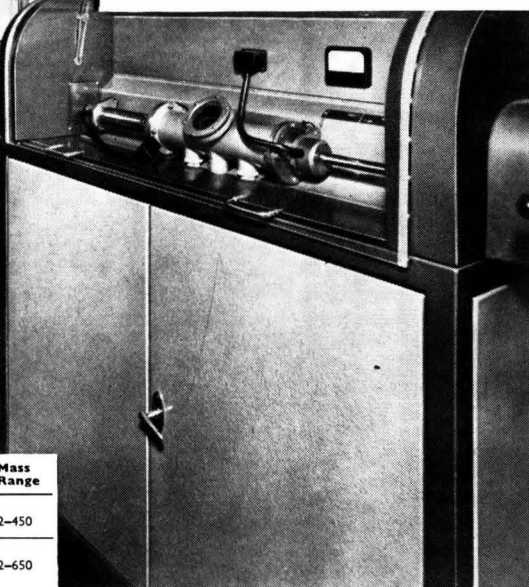

TYPE	PURPOSE	Mass Range
Metrovick MS2-G Mass Spectrometer	For chemical and isotopic analysis of gases and volatile liquids	2-450
Metrovick MS2-H Mass Spectrometer	For analysis of high molecular weight compounds and general chemical analysis	2-650
Metrovick MS2-S Mass Spectrometer	For isotopic analysis of solids using surface ionisation techniques	2-450
Metrovick MS2-SG Mass Spectrometer	For isotopic analysis of solids and gases	2-450
Metrovick MS2-X Mass Spectrometer	For isotopic analysis of uranium hexafluoride and similar compounds	2-450
Metrovick MS3 Mass Spectrometer	For chemical and isotopic analysis of gases and volatile liquids in the low mass range	2-130
Metrovick MS4 Mass Spectrometer	For respiratory gas analysis	18-48
Metrovick MS5 Mass Spectrometer	For routine isotopic analysis of solid samples using surface ionisation techniques	6-400
Metrovick MS6L Mass Spectrometer	For gas leak detection using helium as tracer For gas leak detection using methane as tracer For gas leak detection using argon or butane as tracer	4-32 14-56 30-120
Metrovick MS7 Mass Spectrometer	For analysis of impurities in solids, such as metals, alloys, semi-conductors, graphite, etc.	7-240
Metrovick MS9 Mass Spectrometer (Replacing type MS8)	This is a very high resolution spectrometer for qualitative and quantitative analysis of organic compounds	—

*At Oxford University—A Metrovick MS5 Mass Spectrometer recently installed at the Department of Geology and Mineralogy.*

Full technical details of any of the instruments listed will be gladly supplied on request.

In addition, experts of Metropolitan-Vickers Technical Service are available to advise or assist you on any aspect of mass spectrometric analysis.

**METROPOLITAN-VICKERS**

ELECTRICAL CO. LTD. · TRAFFORD PARK · MANCHESTER, 17

*An A.E.I. Company*

## FOR IMMEDIATE pH MEASUREMENT

The Philips PR.9400 Direct-reading pH Meter is mains-operated and can be used for all pH, redox-potential measurements and potentiometric titrations, including measurements in earthed liquids. Other important advantages of the Philips PR.9400 are current-less measurement on three pH ranges, electrical zero-point at pH7 and provision for the attachment of continuous recording and control instruments. It may be used as a high resistance D.C. millivoltmeter. Both glass and calomel electrodes are available.

### Specification :

Measuring ranges: pH 0-6, 3-9, 8-14  
Sensitivity: Better than 0.01 pH  
Reproducibility: 0.01 pH  
Measuring accuracy: max. 0.02 pH  
Reading accuracy: 0.01 pH  
Stability: Better than .02 pH per 24 hours  
Temperature correction: 0-100°C  
Meter: Moving coil, class 0.5%

"Philips" is the registered trade mark of Philips Electrical Ltd.

Product of N.V. Philips, Eindhoven. Sole Distributors in U.K.:

**RESEARCH & CONTROL INSTRUMENTS LTD.,**  
INSTRUMENT HOUSE, 207 KING'S CROSS ROAD, LONDON, W.C.1. TEL. TERMINUS 8444

(RCL0428)

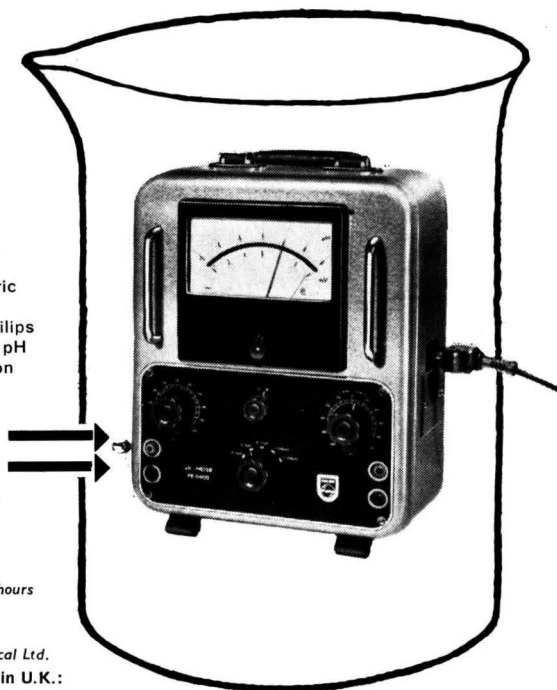

### TALKING SHOP!

They are both research chemists but they work in widely differing fields; their requirements for laboratory chemicals are on the whole distinct. However if you asked them why they obtained their supply of laboratory chemicals from May & Baker they would give you the same answer. They demand reliability and convenience; **M&B** brand laboratory chemicals provide just those qualities. There are now well over six hundred laboratory chemicals in the **M&B** range. The labels on the containers give full individual specifications of the contents.

*Detailed information is available on request.*



**LABORATORY CHEMICALS AND REAGENTS**

MANUFACTURED BY **MAY & BAKER LTD** · DAGENHAM · Tel: *DO Minton 3060 Ext. 320*  
LA 467

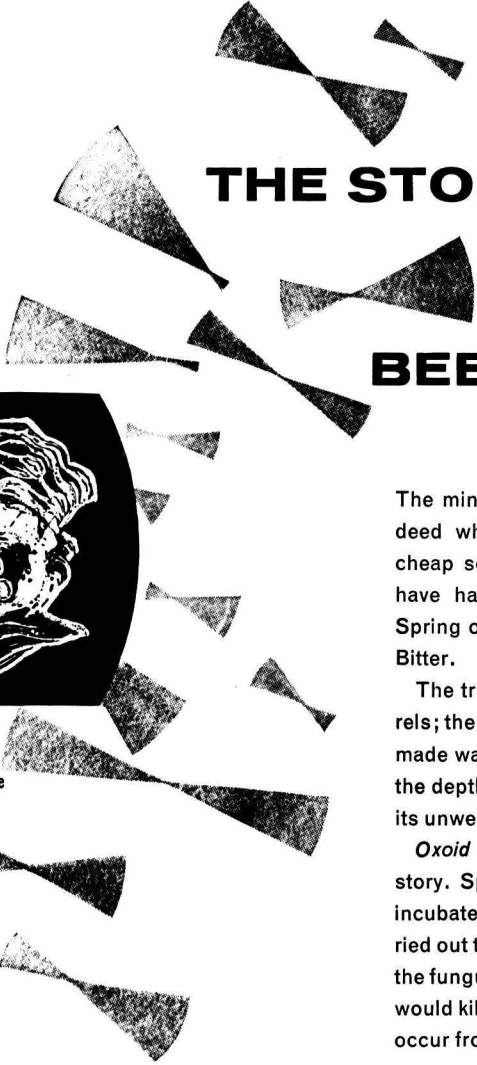

# THE STORY OF THE PERSIAN BEER BARREL



The fungus *Stereum subpileatum* breaks down the cell structure of the wood

The mind of the beer drinker boggles indeed when he finds his pint smells of cheap scent . . . and that is what might have happened to many a man in the Spring of 1957, when he ordered X's Best Bitter.

The trouble was traced back to the barrels; the Persian oak from which they were made was infected with a fungus, living in the depths of the wood, that gave the beer its unwelcome perfume.

*Oxoid Wort Agar* then came into the story. Specimens of infected wood were incubated in the Agar, and tests were carried out to discover effective ways of killing the fungus. The normal steaming of staves would kill the fungus, but reinfection could occur from unheated heads of casks.

FOR PROGRESSIVE LABORATORIES,

**OXOID**

CULTURE MEDIA

The use of **Oxoid Culture Media** ensures constant quality and uniformity in your laboratory technique. Absolutely reliable, quick, convenient and economical, **Oxoid Culture Media** are available in tablet or granular form. Full details from: **Oxoid Division of Oxo Ltd.**, Thames House, London, E.C.4 (CENTRAL 9781)

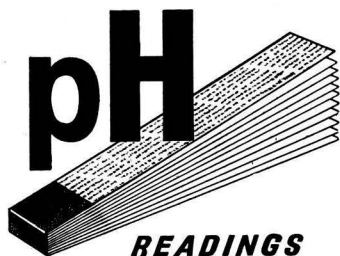
**CONFIDENCE IN****READINGS**

WITH

**JOHNSON  
TEST PAPERS**

Johnson Universal and Comparator Test papers are universally accepted for their accuracy.

Universal Test Papers will give the pH value of any solution to within 0.5 pH in the range of 1 to 10.

Comparator Test Papers give even greater accuracy. They indicate values from 3.6 to 10 pH in steps of 0.3 pH. Comparator Paper No. 1035 determines pH values from 1.0 to 3.5 in steps of 0.5 pH. Johnsons also supply Litmus papers and an extensive range of other Indicator papers for specific uses in Science and Industry. Write for leaflet.

**JOHNSONS OF HENDON LTD.**  
LONDON, N.W.4



**ANALOID REAGENTS  
FOR  
METALLURGICAL ANALYSIS**

A range of compressed chemicals specially prepared for the Analoid System of Analysis.

Full particulars and an outline of all methods supplied on request.

**RIDSDALE & CO. LTD.**  
**NEWHAM HALL, MIDDLESBROUGH**

**NEW  
BRITISH CHEMICAL STANDARDS**

No. 280 Low Carbon Ferro-Manganese  
No. 208/1 High Carbon Ferro-Manganese  
No. 181/1 4%Cu Aluminium Alloy to  
BS 1490: LM14  
No. 182/1 11%Si Aluminium Alloy to  
BS 1490: LM20

Full particulars in list No. 395  
free on request from

**BUREAU OF ANALYSED SAMPLES LTD**  
**NEWHAM HALL, MIDDLESBROUGH**

**PROCEEDINGS OF THE CONGRESS  
ON  
MODERN ANALYTICAL CHEMISTRY  
IN INDUSTRY**

held at  
**The University of St. Andrews**  
**June 24th to June 28th, 1957**

organised by  
The Scottish Section of The Society for Analytical Chemistry

244 pp, cloth

**£2 2s net**

Published by

**HEFFER - CAMBRIDGE**

# VITREOSIL

(Pure Fused Silica)

## LABORATORY WARE



- Highly resistant to thermal shock.
- Completely inert to all acids except hydrofluoric.
- Standard equipment for ashing determinations.
- For repeated use up to 1050°C.

*Leaflets available on request.*

*We also manufacture an extensive range of Vitreosil Industrial Ware*



**THE THERMAL SYNDICATE LTD.**

P.O. BOX No. 6, WALLSEND, NORTHUMBERLAND  
Telephone: Wallsend 6-3242/3

LONDON OFFICE: 9 BERKELEY STREET, W.1.  
Telephone: Hyde Park 1711/2



## Laboratory Chemicals are specially packed



The many different packages used for B.D.H. laboratory chemicals are designed to ensure safety, economy and maximum convenience. Polythene has revolutionized many containers; glass bottles for both solid and liquid chemicals have been redesigned, new 'closures' introduced, double-capped bottles developed to avoid volatilization losses; and brighter, more attractive labels give space for technical information, specifications of purity and warnings on hazardous materials:

There are more than 6,000 laboratory chemicals and reagents in the B.D.H. catalogue, and upwards of a thousand of them are labelled with specifications of purity.

**THE BRITISH DRUG HOUSES LTD.**

# THE ANALYST

THE JOURNAL OF THE SOCIETY FOR ANALYTICAL CHEMISTRY

## CONTENTS

	Page
<b>Proceedings of the Society for Analytical Chemistry</b> .. .. .	329
<b>Report of the Analytical Methods Committee, 1958</b> .. .. .	330
<b>REVIEW</b>	
<b>X-Ray Fluorescence Analysis—F. Brown</b> .. .. .	344
<b>ORIGINAL PAPERS</b>	
<b>Analytical Methods Committee—The Determination of Tocopherols in Oils, Foods and Feeding Stuffs</b> .. .. .	356
<b>A Polarographic Method for Determining Nitrate in Meat and Meat-curing Brines—J. H. Dhont</b> .. .. .	372
<b>The Colorimetric Determination of Dieldrin in Extracts of Coffee Bark—E. John Skerrett and E. A. Baker</b> .. .. .	376
<b>The Spectrophotometric Determination of Silica in Presence of Fluorine and Phosphorus—S. Greenfield</b> .. .. .	380
<b>The Quantitative Determination of Some Noble Metals by Atomic-absorption Spectroscopy—R. Lockyer and G. E. Hames</b> .. .. .	385
<b>The Identification of Lucas 700 Headlamp-glass Fragments by their Physical Properties—D. F. Nelson</b> .. .. .	388
<b>NOTES</b>	
<b>A Systematic Scheme of Semi-micro Qualitative Analysis for Anionic Surface-active Agents: An Addendum—H. Holness and W. R. Stone</b> .. .. .	392
<b>A Composite Spectrophotometric Method for Determining Molybdenum, Vanadium and Titanium in Low-alloy Steels—M. Freearde and Miss B. Jones</b> ..	393
<b>The Simultaneous Spectrophotometric Determination of Ethyl Methyl Ketone and Ethyl Acetate—M. Freearde and Miss B. Jones</b> .. .. .	396
<b>Ministry of Agriculture, Fisheries and Food and Ministry of Health</b> .. .. .	397
<b>Book Reviews</b>	
<b>Gas Chromatography 1958. Edited by D. H. Desty</b> .. .. .	398
<b>Practical Clinical Biochemistry. By Harold Varley</b> .. .. .	398
<b>XV Congresso Internacional De Quimica Pura E Aplicada (<i>Quimica Analitica</i>)</b> .. ..	399
<b>Symposium on Spectrochemical Analysis for Trace Elements. Papers presented at the Sixtieth Annual Meeting of the American Society for Testing Materials</b> .. .. .	399
<b>Publications Received</b> .. .. .	400