

174.116.97

# The Chemical Age

VOL LXIX

12 DECEMBER 1953

No 1796



*Branches at*  
81, Fountain Street, Manchester, 2  
65, West Regent Street, Glasgow, C.2  
40, Queen Street, Belfast, N.I  
Morrison, Nr. Swansea, S. Wales

# Ask Berk

for

**Acids**

**Chemicals**

**Drugs and Botanicals**

**Filter Aids, Bentonites  
and Zircon**

**Mercurials**

**Metal Powders**

**Pneumatic Drying Installations**

**Protective Coatings**

**F. W. BERK & Co. Ltd.**

**COMMONWEALTH HOUSE,  
1-19, NEW OXFORD STREET,  
LONDON, W.C.1.**



Phone: CHAncery  
6041 (16 lines)

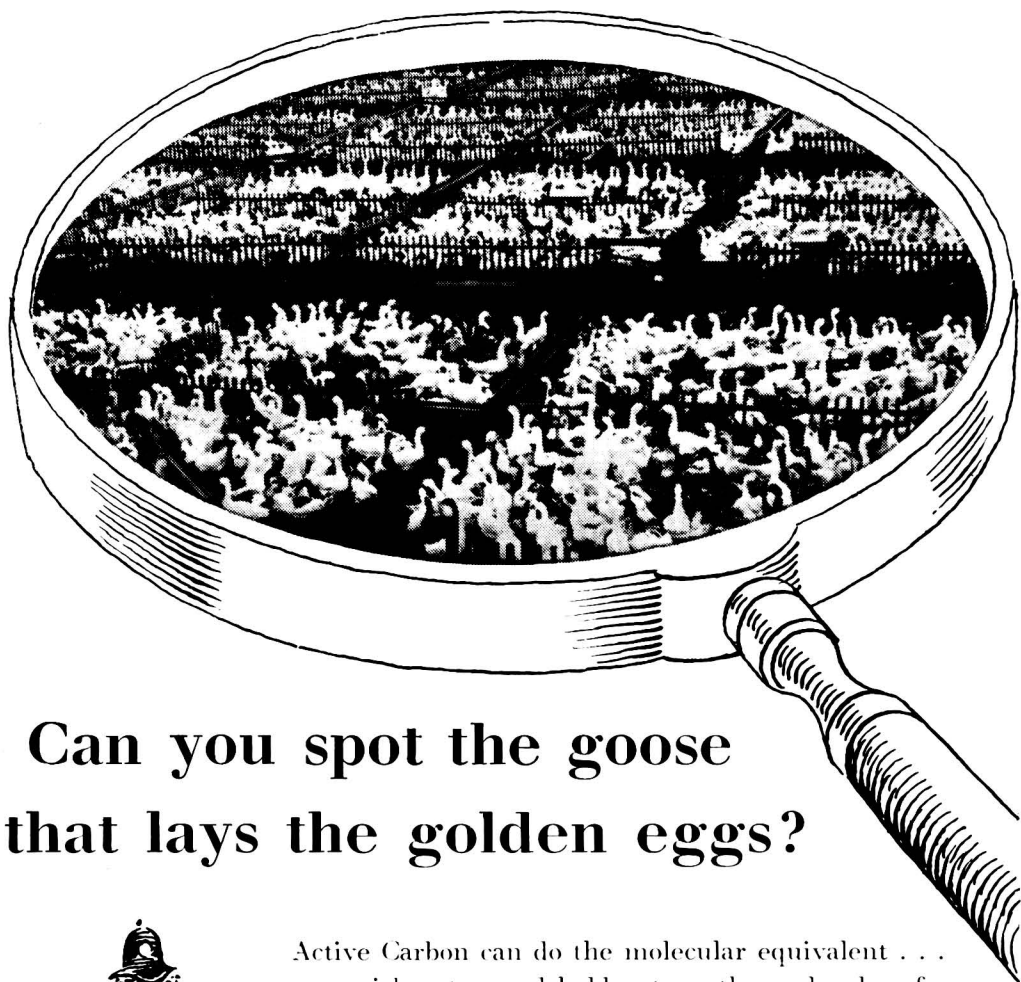

## Can you spot the goose that lays the golden eggs?

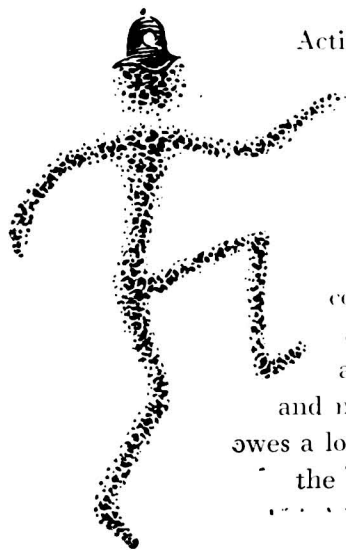

Active Carbon can do the molecular equivalent . . . pick out — and hold onto — the molecules of an expensive solvent dispersed in the air, for instance.

In hundreds of dry-cleaning works, chemical works and paint shops the use of Active Carbon pays

handsome dividends. But solvent recovery is only one of its gifts: it can also remove unwanted colours, unpleasant odours and tastes. It is used as a catalyst carrier in the manufacture of P.V.C. : and the purity of many foodstuffs

and many pharmaceuticals owes a lot to Active Carbon ; the experts in charge are

**SUTCLIFFE  
SPEAKMAN**

The valve with the  
*world-wide* reputation

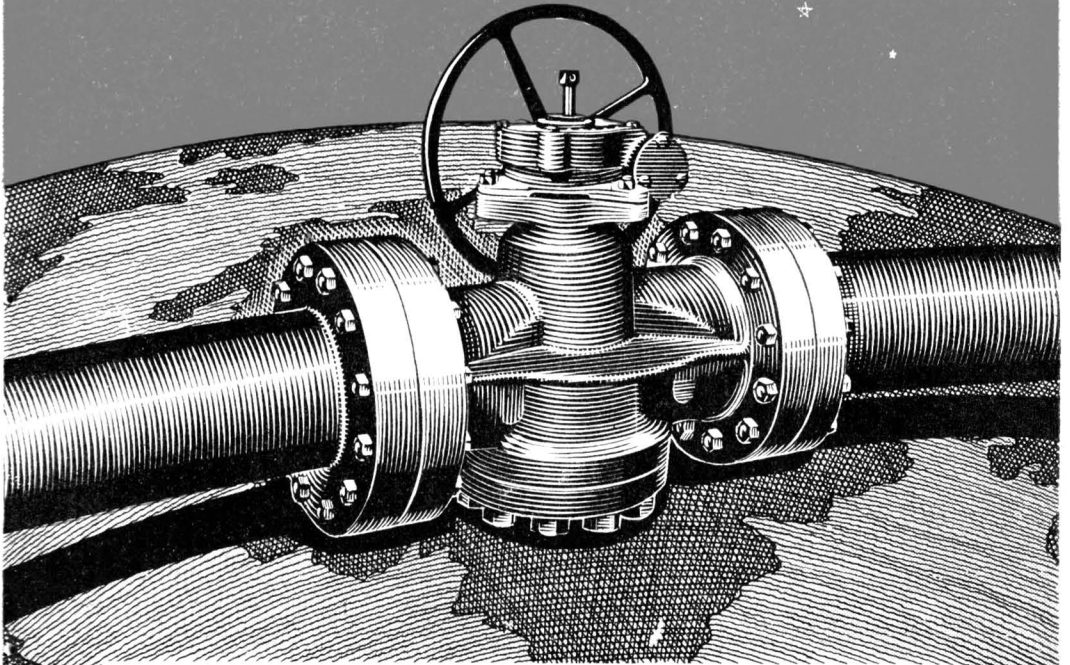

AUDCO Lubricated Valves are in daily use in the Chemical Industry throughout the world, where their effectiveness has been proved under the most adverse conditions. They handle almost all fluids and gases, whether corrosive or erosive, with equal efficiency and economy. The more recently developed Inverted Type Audco Valve shown above is recommended in place of the Standard Type on the larger-sized lines.

**AUDCO**  
*Lubricated*  
**VALVES**

Audley Engineering Co., Ltd., Newport, Shropshire

# COMBATING CORROSION

The C.I.D. at work

(Corrosion Investigation Department).

## TESTING ABRASION RESISTANCE

For protecting plant where corrosive action is accompanied by abrasion, St. Helens technologists have developed a special compound of natural rubber. As with all 'Cabtyrit' compounds, exacting tests are applied to ensure uniformity in production and dependability in service. The following standard compounds are available to meet conditions arising in chemical plants:

### NATURAL RUBBER

A number of anti-corrosive grades for general application for temperature conditions up to 160° F. (70° C.).

### HEAT-RESISTING NATURAL RUBBER

Especially for general application and where elevated temperature conditions exist—up to 212° F. (100° C.).

### ABRASION-RESISTING NATURAL RUBBER

A resilient lining designed to give maximum resistance to abrasive conditions.

### EBONITE (HARD RUBBER)

To give protection against very severe corrosive conditions.

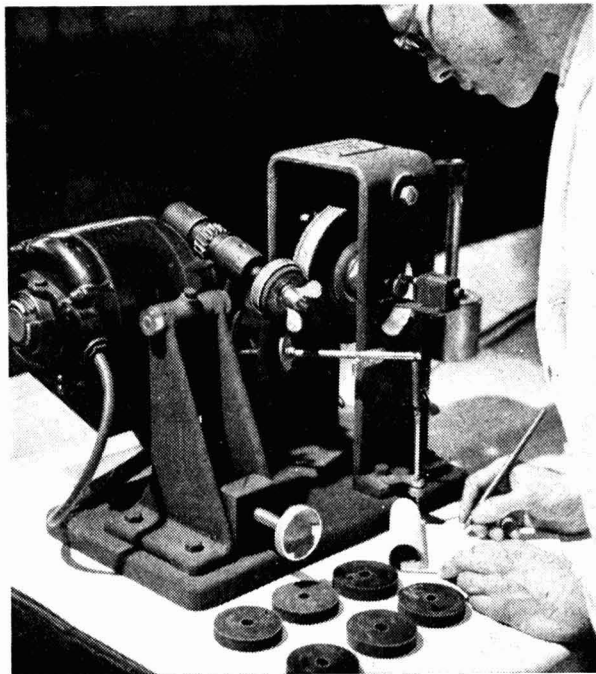

### FLEXIBLE EBONITE

A special grade of ebonite for use on equipment subjected in operation to physical shock and impact.

### POLYCHLOROPRENE (NEOPRENE)

Suitable for conditions which involve elevated temperatures and/or oils, solvents and greases.

### POLYVINYL CHLORIDE (P.V.C.)

Particularly suitable for the storage of Nitric and Chromic Acids at normal temperatures and up to 140° F. (60° C.).

# St. Helens

'CABTYRIT'

## ANTI-CORROSIVE SERVICE

St. Helens make a scientific approach to the problem of combating corrosion, and have the necessary experience and resources to investigate any problem of plant protection. Special compounds will be developed where necessary. Enquiries are invited.

ST. HELENS CABLE & RUBBER CO., LTD.  
SLOUGH, BUCKS. Telephone: SLOUGH 20333

# Propylene derivatives...

**PROPYLENE GLYCOL**



**DIPROPYLENE GLYCOL**



**PROPYLENE OXIDE**



**1:2 - DICHLOROPROPANE  
(PROPYLENE DICHLORIDE)**



**ISOPROPYL ALCOHOL**



**ISOPROPYL ETHER**



**ACETONE**

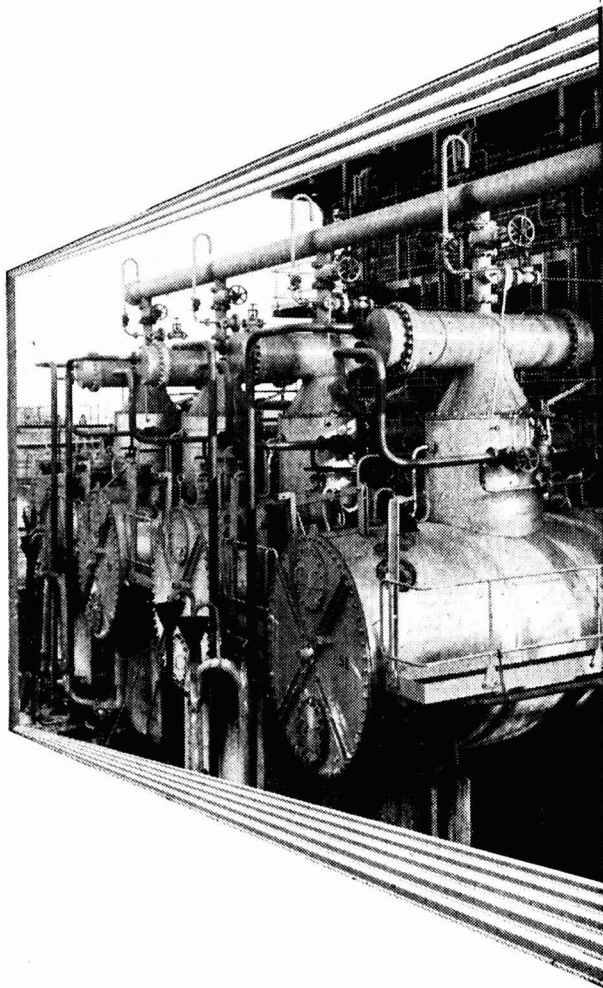

*Full information, samples and prices  
on request to the manufacturers:*

## **PETROCHEMICALS LIMITED**



LONDON SALES OFFICE  
170, Piccadilly,  
London, W.1  
Telephone: MAYfair 6618

MANCHESTER SALES OFFICE  
Partington Industrial Estate,  
Urmston, Manchester.  
Telephone: Irlam 2601

# DICYANDIAMIDE

*now available  
for immediate delivery  
from*

CHEMICALS DIVISION

**THE BRITISH OXYGEN CO. LTD.**

VIGO LANE, CHESTER-LE-STREET, CO. DURHAM. Telephone : Birtley 145



**A NEW FIBREFREE FILTER PAPER**

*the complete wet-strength equivalent of the standard*

*Postlip paper is made by EVANS, ADLARD & CO. LTD.*

ENQUIRIES AND ORDERS FOR "POSTLIP" PAPERS SHOULD BE ADDRESSED TO OUR SALES REPRESENTATIVES :

**TECHNICAL PAPER SALES LTD., 9, Bridewell Place, London, E.C.4**  
Telephone : CENTRAL 9833

# Beneath the foam is **NANSA S\***

Developed primarily as a basic ingredient of detergent powders, no comparable British product has so many applications as NANSA S. This 40% active dodecyl benzene sodium sulphonate covers practically the whole field of domestic and industrial detergents. It serves as a wetting-out, detergent, emulsifying, dispersing and foaming agent in the textile industry; as the basis of heavy duty detergents for laundry,

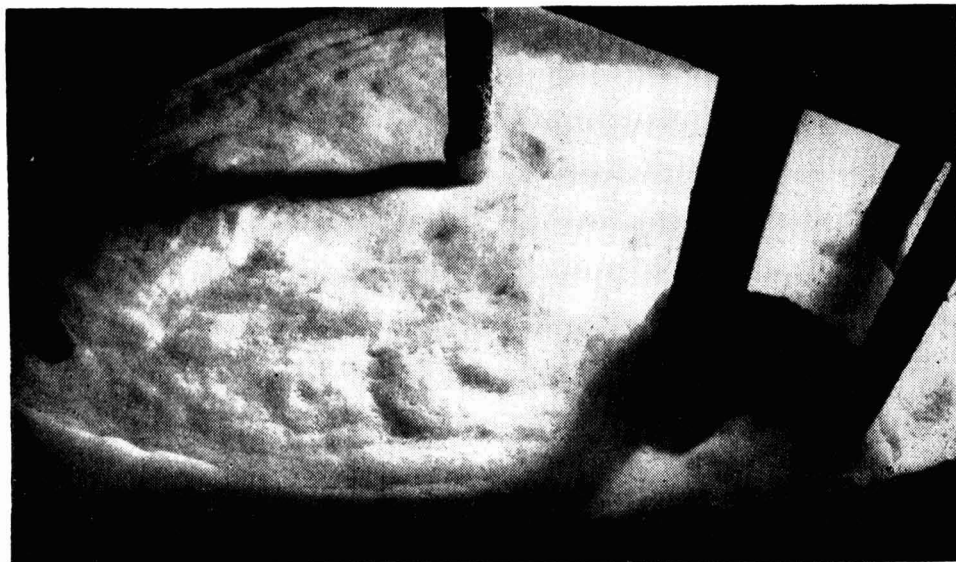

household, dairy and industrial uses and of light duty detergents for household use; in floor cleaners, printing ink, metal polishes and scouring powders, in paper processing, electroplating, glass cleaning and the manufacture of compound fertilizer.



**\* CHARACTERISTICS:** Non-hygroscopic, free-flowing powder in bead form. White to pale cream. Faint characteristic odour. Simple to store, handle and weigh. Cheaper to transport than liquids. Has good lime soap dispersion and wetting powers, lends itself readily to the preparation of homogeneous blends with diluents or builders, and has a high foaming capacity in all natural waters.

AGENTS & OFFICES IN PRINCIPAL CITIES OF THE WORLD

MARCHON PRODUCTS LTD. Head Office: Whitehaven. Telephone: Whitehaven 650-1-2 & 797-8-9 (6 lines)  
Telegrams: Marchonpro, Whitehaven. London Office: 140, Park Lane, W.1. Telephone: Mayfair 7385-6-7  
Telegrams: Marchonpro, Audley, London.

Manufacturers of fatty alcohol sulphates (EMPICOLS) emulsifiers (EMPILANS) self-emulsifying waxes (EMPIWAXES) alkyl aryl sulphonates (NANSAS) and other detergent bases, activators and emulsifiers in powder, paste and liquid forms, and other industrial chemicals

# FLUOR SPAR

## HIGH GRADE

### GLEBE MINES LTD.

EYAM . . . Nr. SHEFFIELD

*Telephone: EYAM 281 12 - Telegraphic Address: FLUORIDES EYAM*

## HOLMES - KEMP

### ADSORPTIVE

# DRYERS

#### FOR AIR OR GAS

The Holmes-Kemp dynamic dryer treats air or gas for complete removal of water vapour utilising Silica Gel or Activated Alumina as the adsorptive medium.

Heat for re-activation can be supplied by electricity, town gas or steam as desired.

*Dewiled brochure available on request.*



**W. C. HOLMES & CO. LTD. HUDDERSFIELD**

Telephones: Huddersfield 5280. London. Victoria 9971. Birmingham, Midland 6830.

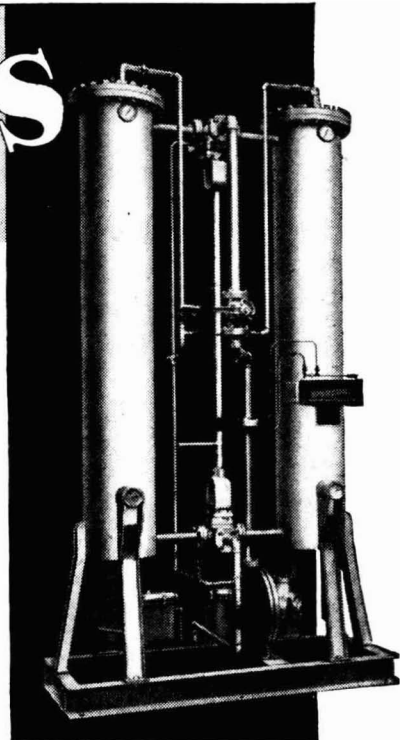



*An absolutely first-class  
machine for grinding...*

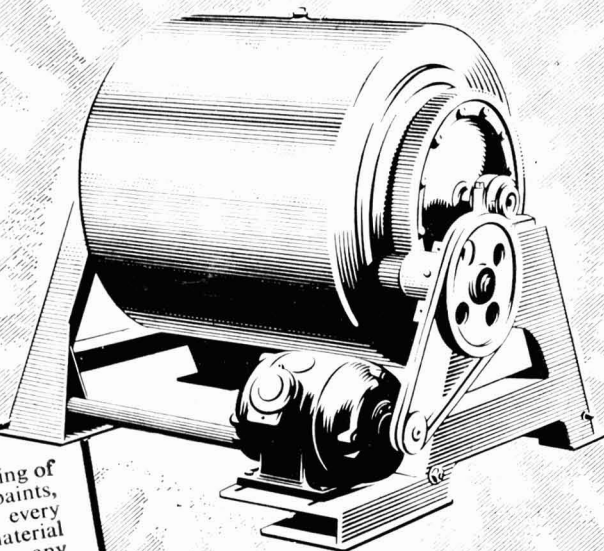

For wet or dry grinding of clay, quartz, glazings, paints, printing ink, and every possible kind of raw material of any hardness to any defined degree of fineness.

Compact, ruggedly built and simple to operate, the Coborn Ball Mill is a first-class investment at the right price. If you have a grinding problem, it will pay you to consider using the 'COBORN'!

Can be supplied with or without motor, and with sillex lining, according to requirements.

*...the* **COBORN**  
PORCELAIN LINED  
**BALL MILL**

★ ASK TO-DAY  
for prices and  
details, from the  
sole U.K.  
Distributors.

**GEORGE**  **COHEN**

SONS AND COMPANY LIMITED

WOOD LANE, LONDON, W.12. Telephone: Shepherds Bush 2070.

Telegrams: Omniplant, Telex, London. STANNINGLEY.

Nr. LEEDS. Telephone: Pudsey 2241. Telegrams: Coborn, Leeds

And at Kingsbury (nr. Tamworth) · Manchester · Glasgow · Swansea · Newcastle · Belfast  
Sheffield · Southampton · Bath



## ATOMISATION.

If you wish to disintegrate a liquid, there is little YOU can do about changing the physical properties of the liquid except to heat it.

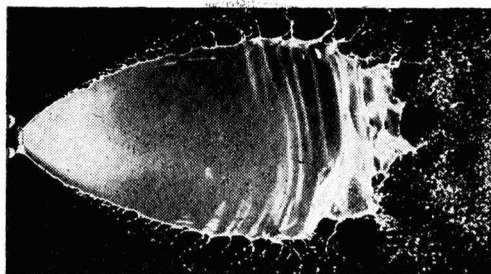

The initial stage of atomisation.  
Exposure 1 micro second.

### BUT

You can do something about your atomising plant. You can consult URQUHART'S (1926) LTD. who have been manufacturing Atomisers for over twenty-five years. Single or two-fluid atomisers from 1-lb. to 2,000-lbs. of liquid per hour.

### LET URQUHART'S SOLVE YOUR ATOMISATION PROBLEMS

Also manufacturers of Fuel Oil Burning Equipment for all purposes including Combustion Chambers rated at  $10^6$  B.Th.U.s per cubic foot per hour and with positive control of combustion conditions.

## Urquhart's (1926) Ltd

33, Chase Road  
London, N.W.10  
Elgar 3331.



Albion Dockyard  
Bristol 1.  
Bristol 23050.

... if you can't  
**PREVENT...**  
**YOU CAN**  
**SAFEGUARD...**



Boys will be boys—and when there's a hot day—and convenient stream—what is more natural than their wish for a "dip"? If you have an **EFFLUENT PROBLEM** it is almost certain that we can be of help. The use of **ALUMINIUM SULPHATE** is frequently an essential step in the process of producing a satisfactory liquid effluent. We should be glad to examine your present effluent and offer our advice . . . . .

THE  
**ALUMINA** COMPANY LIMITED.  
**IRON BRIDGE WORKS WIDNES**  
LANCASHIRE.

Tel:  
**WIDNES**  
2275

## STEEL SHAW

### PEBBLE MILLS

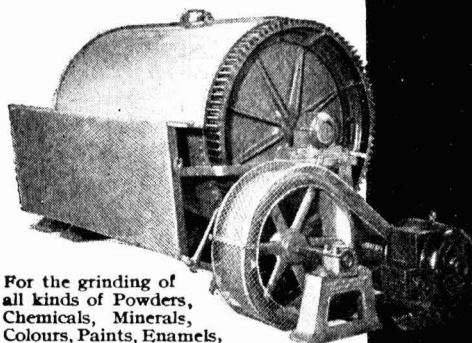

For the grinding of all kinds of Powders, Chemicals, Minerals, Colours, Paints, Enamels, etc. Supplied lined with hard Porcelain, Sillex, or special linings, and can be insulated to suit particular classes of work.

Send for our free illustrated literature  
**STEELE & COWLISHAW, LTD.**,  
Engrs. (Dept. No 12) Head Office & Wks.  
**COOPER STREET, HANLEY,**  
**STOKE-ON-TRENT**

Telephone: Stoke-on-Trent 2109  
London Office: 329, High Holborn, W.C.1  
Telephone: Holborn 6023.

Nearly a Century's Experience in Grinding

**Announcing**

**another NEW DISTEC product**

HG 271

**HARDENED CASTOR OIL**

HG 271 is a hard solid of high melting point—chemically a glyceride, but physically resembling a wax, with practically no odour. It has many important uses, notably in the manufacture of lithium, barium and sodium greases. It is also of interest to the wax, plastics, candle and polish industries.

**Average Tests of HG 271**

F.F.A. (as Oleic Acid) . . . . .	2 per cent max.
Acid Value . . . . .	4 max.
Saponification Value . . . . .	180-187
Iodine Value (Wijs) . . . . .	3 max. usually 1-2
Hydroxyl Percentage . . . . .	4.5-4.8
Melting Point (°C) . . . . .	85-87

(Complete fusion, capillary tube)

**Your special needs**

*We shall be delighted to give further information and to discuss with you your own special needs and problems. Why not write us today?*



**fatty acids and glycerides**

HESS PRODUCTS LTD. 4 ALBION STREET LEEDS 1 Leeds 22827

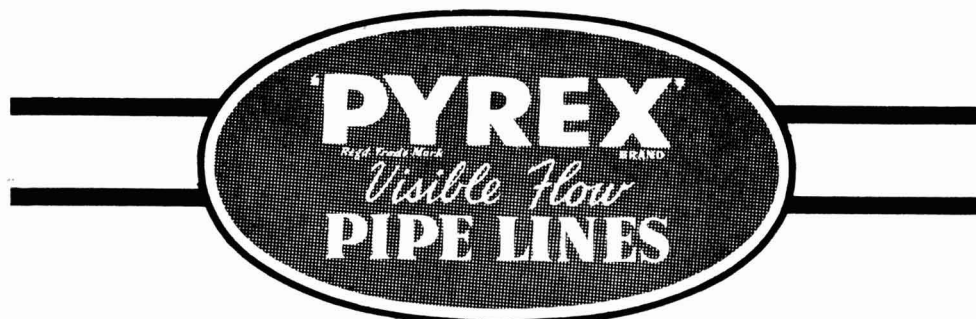

**JAMES A. JOBLING & CO. LTD.**

HAVE PLEASURE IN INTRODUCING

**Q.V.F. Ltd.**

(QUICKFIT VISIBLE FLOW)

James A. Jobling & Co. Ltd. and Quickfit & Quartz Ltd., have jointly formed this new Company to be their **sole selling agency** for Pipeline and Chemical Plant fabricated from 'PYREX' Brand Glass.

The Company will, as from 1st December, 1953, handle all new enquiries and orders of 'PYREX' *Visible Flow* Glass Pipelines and 'Quickfit' Chemical Glass Plant.

Q.V.F. Ltd., will undertake the standardisation, development and design of Glass Chemical Plant and Pipework for the Chemical, Food and Associated Industries, offering to all past, present, and future customers, a complete engineering service from design to erection of Glass Plant.

All our friends are asked to contact

**Q.V.F. Ltd.**

**Mill Street, STONE,**

**Staffordshire.**

*Telephone : Stone 511*

for all their requirements in Industrial Glassware.



**James A. Jobling & Co. Ltd.**  
**Wear Glass Works**  
**Sunderland**

The original and only makers of 'PYREX' Brand Glass in the United Kingdom.



---

Volume LXIX

Number 1796

*Established* 1919

---

# The Chemical Age

*The Weekly Journal of Chemical Engineering and Industrial Chemistry*

---

BOUVERIE HOUSE · 154 FLEET STREET · LONDON · EC4

---

Telephone : CENTRAL 3212 (26 lines)

Telegrams : ALLANGAS · FLEET · LONDON

## CONTENTS · 12 DECEMBER 1953

Papilloma of the Bladder	1218
Research Work in the Coal Industry	1219
Annealing of Copper Strip	1221
The Complete Synthesis of Cortisone	1222
Detection of Traces of Oxygen	1226
Rigid PVC & Its Applications	1227
Low Alloy Steels Analysis	1229
Anti-Static Rubbers	1230
Problems in Biochemical Engineering	1231
Technical & Technological Education	1233
The Chemist's Bookshelf	1235
Home News Items	1237
Overseas News Items	1238
Personal	1239
Publications & Announcements	1241
Law & Company News	1242
Next Week's Events	1244
Market Reports	1244

---

*Editor : E. A. Running*

*Publisher & Manager : John Vestey*

**MIDLANDS OFFICE :**  
Daimler House, Paradise  
Street, Birmingham

Phone : Midland 0784/5

**SCOTTISH OFFICE :**  
116, Hope Street,  
Glasgow, C.2.

Phone : Central 3954/5

**LEEDS OFFICE :**  
Martins Bank Chambers,  
Park Row, Leeds, 1

Phone : Leeds 22601

SINGLE COPY 1/- (BY POST 1/3)

ANNUAL SUBSCRIPTION 42/-

# HYDROFLUORIC ACID

**ANHYDROUS AND SOLUTIONS ALL STRENGTHS  
ALSO PURE REDISTILLED 40% w/w**

## FLUORIDES, Neutral

Sodium, Magnesium, Barium,  
Potassium, Lead, Zinc, Ammonium,  
Aluminium Lithium, Chromium.

## BiFluorides (Acid)

Ammonium Sodium, Potassium.

## Double Fluorides (Cryolites)

Sodium HexafluoroAluminate  
Potassium HexafluoroAluminate

## SILICOFLUORIDES

Magnesium, Zinc, Ammonium,  
Barium, Potassium, Lead,  
Hydrofluosilicic Acid.

## BOROFLUORIDES

Sodium, Potassium, Ammonium,  
Lead, Copper, Zinc, Cadmium,  
Fluoboric Acid Solution.

OTHER FLUORIDES TO SPECIFICATIONS.

### Glass Etching Acids

Ammonia White Acid and VITROGRAPHINE.

## JAMES WILKINSON & SON, LTD.

TINSLEY PARK ROAD, SHEFFIELD, 9

Phone 41208/9 'Grams "CHEMICALS" Sheffield



## Plant for the Chemical Industry

for ACID NEUTRALIZATION, CLARIFICATION OF LIQUIDS,  
DEWATERING OF SLUDGES, EFFLUENT PURIFICATION,  
FILTRATION AND FLOCCULATION, PICKLING LIQUOR  
TREATMENT, PURIFICATION OF TRADE WASTE, SEDI-  
MENTATION AND THICK-  
ENING, SEPARATION OF  
SOLIDS FROM LIQUIDS,  
SODA RECOVERY. WET  
MATERIAL HANDLING

Including

AGITATORS CAUSTICIZ-  
ERS, CLARIFIERS, CLASS-  
IFIERS, CONVEYORS,  
DEWATERING MACHINES,  
ROTARY, VACUUM FIL-  
TERS, SAND WASHERS,  
SLUDGE PUMPS,  
THICKENERS, etc.

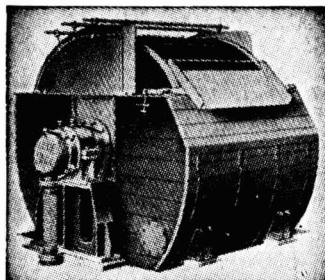

Rotary Pulp Washing Machine, with  
Pitch Pine Trough, Wash Gear and  
Scraper Knife

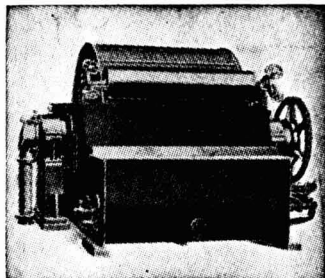

Rotary Vacuum Filler, with Take-off  
Roller and Repulper

## UNIFLOC LIMITED

— SWANSEA —

Phone : Swansea 55164 (3 lines)

Grams : Unifloc, Swansea

---

## Taking the Air

---

THE Interim Report of the Beaver Committee on Air Pollution has already been widely discussed in the daily Press—indeed, the amount of space so swiftly devoted to it reflects the greatest credit upon British newspapers. For, like a good many social problems of our changing times, air pollution, or at any rate what can be done about it, depends considerably upon public opinion. Smoke, fog, and their monster-child smog, are by no means new problems. John Evelyn's 'Fumifugium, or the Inconvenience of the Aer and Smoake of London Dissipated,' dated 1661, is a three-century forerunner of the Beaver Committee's Report, differing only in that it was a self-appointed investigator whose conclusions and suggestions were being presented. When Evelyn said, 'Sure we are, how much the Respiration is perturb'd, and concern'd, when the Lungs are prepossessed with the gross and dense vapours, brought along in the Aer,' he was firmly on the same ground as the 1953 Committee who state that 'Pollution has long been thought to be associated with respiratory disease in both its acute and chronic forms, and it is possible that some carcinogenic substance in smoke plays a part in the causation of cancer of the lung.'

There is a fundamental difference between the London smoke problem of Evelyn's day and the smog problem of our twentieth century cities. Then Evelyn laid the full blame upon factory chimneys, upon the 'Brewers, Diers, Lime-burners, Salt, and Sope-boylers.' Modern legislation, mainly of this century, has greatly dissolved the problem of industrial smoke emission; but all our centres of manufacture and business have become centres also of

congested residence, and none of the smoke prevention bylaws apply to private houses. Rightly, the Beaver Committee says, 'Domestic smoke, being discharged at low temperature and at a low level, and principally arising when fog is normally prevalent, has in densely populated areas the greatest effect in forming smog.'

The estimated annual air pollution in Great Britain from solid fuel usage is 2,100,000 tons of smoke, 600,000 tons of grit, 5,000,000 tons of sulphur dioxide, and 20,000,000 tons of carbon monoxide. Unfortunately these totals, grim enough without any worsening, are not averaged in time or place. The pollution is much more concentrated in thickly populated areas and it is intensified in winter months. Though district measurements of air pollution are now undertaken under the guidance of a DSIR research committee, with 160 local authorities or other bodies co-operating, relatively few daily measurements are made. The Beaver Committee calls for a substantial increase in local pollution measurement, for without this fuller recording of the facts 'it is impossible to gauge the magnitude of the problems to be solved, or to measure the effects of changing conditions or ameliorative action.'

Fogs are natural and uncontrollable phenomena. Apart from their effect upon visibility, fogs themselves are relatively harmless. Smoke makes fogs more persistent and frequently by providing formation nuclei and by cutting off sunshine, thus retarding the natural fog remedies of heating and evaporation. The smog hazard is markedly serious, therefore, in areas or regions with high fog frequency and high population density. The Beaver Committee Report gives as an appendix an excellent map,

charting the black spot centres for smog, and these are regrettably numerous. London in this matter is not at all alone.

One immediate recommendation of the Committee, though put forward as a palliative and not in any sense as a solution, is simple and sensible. Warnings should be issued, particularly through the BBC, whenever serious fog is likely to obtain for at least 24 hours. According to official statements this recommendation was already accepted and put into force even before the public issue of the Report. At such times of maximum smog risk, householders should not bank coal fires at night, nor burn rubbish or bonfires; those who can use smokeless fuels should ensure that only these are used, and the admixture of coke to coal is suggested at times of special risk. Factories, large buildings, etc., should immediately bring all smoke prevention actions into maximum effect. Drivers of all motor vehicles should switch off engines whenever stationary, even temporarily. If the fullest possible public co-operation could be secured the results may be much greater than the Committee apparently envisages.

Can public opinion be sufficiently engaged? We would like to be optimistic but it is difficult to ignore the social and psychological prototype of the road accident problem, the deadly facts of which are even more starkly obvious. Will 'smoke sense' be stimulated without penalties and compulsions when even with these directive influences road sense is still so unevenly displayed? This analogy is more appropriate than most. The road user can rightly blame much of the accident-risk upon bad and obsolete roads; the private fuel user can equally blame smoke upon bad combustion appliances and scarcities of smokeless fuels. In both cases, however, the consequences of basically unhelpful conditions could be greatly eased by intelligent adjustment. There is perhaps one hopeful difference. On the roads a majority compliance with safety requirements is not enough to prevent serious accidents; with smoke, the reduction in smog risk is likely to be proportional to the extent of private anti-smoke action.

The longer target of smoke prevention rests on the use of smokeless fuels in

all domestic appliances' and the Committee finds it a plain and inescapable fact that 'there is nothing like enough smokeless fuel in the country for this purpose either now or in sight within the next few years.' The eminently practical suggestion is made that enough production to supply the worst 'smog-liable' areas might be developed within only a few years. Action along these lines must bring legislation. A priority of distribution of smokeless fuel must be associated with some compulsion of usage, but we are already insisting that only pasteurised or attested milk shall be distributed in areas where the supply of these grades is adequate, a technico-legal development that is more complex and advanced than the prescribed use of smokeless fuels. The Committee has been much less bold on the matter of appliances. 'We are at the same time examining whether there are possibilities of material reduction in smoke emission by developing and using domestic appliances to burn bituminous coal smokelessly.' It is to be hoped that Dr. Harold Hartley's views will be obtained by the Committee for in his Melchett Lecture he observed that 'it can be stated definitely that most of the technical problems associated with the burning of bituminous coal in the home, virtually without smoke production and at high overall efficiencies have been solved.'

But apart from smog and the less dramatic everyday damage that is caused by air pollution, what an appalling wastage of resources is revealed by the figures for chimney effluents! Twenty million tons of carbon monoxide—the calorific value of nearly 6,000,000 tons of coal, more than a thirtieth of the total tonnage used by both industry and homes! Five million tons of sulphur dioxide, equivalent in sulphur to 2,500,000 tons and convertible (theoretically) into four times our annual requirement of sulphuric acid! Wastage recovery can never achieve full measure but surely coal, one of our few basic resources, should be handled more respectfully. The facts of national economics as well as the London death certificates of December, 1952, cry out against the crime of air pollution.



## Notes & Comments

### Dealing with Waste CN

CYANIDE waste from the manufacture of benzyl cyanide has been disposed of by a new method based upon old knowledge. The main reaction involves using a surplus of cyanide so that the waste effluent contains 10,000 ppm. of sodium cyanide. Chlorination was first considered, as at pH greater than 8.5 the much less toxic cyanate is produced; however, both the cost of chlorine and of the plant for treatment were formidable, and a further examination of the whole problem led to a literature research. In this search an old German process—the heating of cyanide to produce ammonia and formate—was encountered. This method has now been effectively introduced. The effluent is led into an iron vessel and heated to 160–170° for six to seven hours. The cyanide content is reduced from 10,000 to about 4 ppm. and, after dilution with other process waste water, the finally discharged effluent has no more than 0.4 ppm. (*Chemical Week*, 1953, **73**, [21], 57.) The US organisation concerned is said to be uninterested in patenting the disposal treatment, which is believed to be just as applicable to larger volumes of waste cyanide liquors. The original German process was not developed with any disposal-treatment purpose; it was investigated as a possible means of ammonia production.

### Chlorophyll Candour

IN *Canadian Chemical Processing* (1953, **37**, [October], 96) H. C. Ehrmantraut of the Illinois Institute of Technology has presented a brief but commendably realistic picture of chlorophyll research today. Claims for chlorophyll's therapeutic properties are far from novel; they go back at least 35 years, and more than 20 years ago a monograph on this subject was published. One of the major confusions is the general use of the name 'chlorophyll' for what, in fact, is a variable range of 'chlorophyll derivatives.' Chlorophyll is a sensitive

substance and will suffer modification even under mild treatment, and 'whole families of degradation products are readily produced.' Much of the pharmacological work of the past has been carried out with derivatives 'prepared by gross treatment of green leaf extracts with no stringent efforts to purify the chlorophyll prior to treatment or to isolate single components of the reaction mixture.' All that has come from acetone extracts of green foliage is certainly not chlorophyll. Ehrmantraut calls for a critical re-examination of chlorophyll's biological effects with emphasis laid upon the relative properties of different derivatives. These should not only be prepared from dried leaf meal as generally used commercially, but also from fresh green leaves to ensure that the starting material has not suffered change during leaf meal preparation. Three major fields for study are suggested: odour elimination, bacteriostatic power, and wound healing. Surprisingly Ehrmantraut omits the cardiac field though it was as a heart stimulant that chlorophyll initially raised clinical hopes. A comprehensive research study by a group of workers is badly needed at a time when 'the true value of chlorophyll preparations is largely obscured by the trumpeting of advertising agencies.'

### Magnesium versus Petrol ?

AT a recent meeting of the Magnesium Association in New York, the use of pulverised magnesium as a fuel for cars and aircraft was prophesied. Three hundred and fifty pounds of this metallic element potentially has the power of 18,000 pounds of aviation spirit. Magnesium powder alone would not seem likely to be successful as a fuel; the presence of a stabiliser is necessary. Efforts in the past to develop magnesium as a power-fuel involved mixing the powdered magnesium with powdered aluminium, but the formation of aluminium oxide led to operative difficulties. Now it is claimed that a specially designed aeroplane engine has already been built for mag-

nesium-fuelling; pending patent establishment details of this engine have been kept secret, and the stabilising agent remains unnamed. The agent cannot be substantially present in the mixture for the final fuel has a magnesium content of over 95 per cent. Fineness of grinding is fundamental. The standard mentioned in New York was six microns, obtained by a hammer mill from magnesium ingots of high purity (over 99 per cent). Waste magnesium from borings, etc., has so far not been a successful source of the element for producing a working fuel. A special oxidising agent is not apparently required; in the test engine air was used.

### *Prospects Rosy*

**T**HERE seem at least two general arguments favouring this eventual development. First, the world's reserves of hydrocarbon oils are limited; even the occasional discovery of new

fields does not wholly offset the stark facts about the stocks of oil left in old ones. Second, the product of magnesium oxidation is not gaseous, and it is increasingly obvious that the air of thickly populated areas is being seriously polluted by products from the internal combustion engine. These are not powerful arguments today, but in 20 or 40 years' time they may well be decisive. The supply of magnesium would certainly present little difficulty; the extraction-from-sea-water process is capable of unlimited extension. Next to sodium, magnesium is the most abundant metal of sea water. A cubic mile of sea water contains 26,000,000 tons of magnesium salts, about a fifth of the tonnage of sodium chloride present. The disposal of the oxide left after magnesium fuel combustion would not present any major difficulties for it would have regular value as a liming agent for the soil. In theory, therefore, and looking distantly ahead, the prospects of a huge powdered magnesium industry are quite rosy.

---

### *Papilloma of the Bladder*

THE disease papilloma of the bladder has been added to the list of diseases prescribed under the Industrial Injuries Act by Regulations made by Mr. Osbert Peake, Minister of Pensions and National Insurance.

The Regulations came into force on 7 December. They provide Industrial Injuries benefits for persons suffering from the disease as a result of certain specified occupations in which they have been employed at some time since 5 July, 1948, the date the Act came into operation.

Most of the occupations covered are in the chemical industry, mainly in certain processes involving contact with the chemicals  $\alpha$ -naphthylamine,  $\beta$ -naphthylamine or benzidine, or any of the salts of those substances. Cover is also given to workers engaged in the production of the dyes auramine or magenta. (There is nothing to indicate that the finished dyes are in any way harmful.) The disease has often been referred to in the past as 'aniline tumour' or 'aniline cancer,' but recent research does not support the view that aniline is a cause. (See THE CHEMICAL AGE, 5 December, p. 1183.)

---

The National Insurance (Industrial Injuries) (Prescribed Diseases) Amendment (No. 2) Regulations 1953 (SI. 1953, No. 1740) are obtainable from HMSO price 3d.

---

### *Output of Rubber*

FOR the month of October world production of natural rubber totalled 142,500 tons. This was 2,500 tons above the figure for the previous month and brought to 1,410,000 tons the total output for the first ten months of this year.

World consumption during the month was 132,500 tons, the total for the first ten months thus being increased to 1,305,000 tons. The Rubber Study Group Secretariat reports that on 31 October world stocks of natural rubber stood at 822,500 tons.

World production of synthetic rubber in October reached its lowest monthly level this year at 64,000 tons, compared with 67,500 tons in September. For the third month running, world consumption of synthetic rubber was 65,000 tons.

# Research Work in the Coal Industry

## Discussion by Parliamentary & Scientific Committee

AT a meeting of the General Committee of the Parliamentary and Scientific Committee on 5 November, the chairman (Sir Wavell Wakefield, M.P.) announced that it had been decided to devote this meeting and the next one or two to a study of the application of science in the coal industry. He then welcomed the two speakers who were to inaugurate the discussion: Sir Hubert Houldsworth, Q.C., D.Sc., chairman of the National Coal Board; and Dr. D. T. A. Townend, Director of the British Coal Utilisation Research Association.

Sir Hubert spoke as follows:—

I think it would be no exaggeration to say that before nationalisation the application of science to the coal mining industry was confined to coal preparation, to carbonisation problems, and as far as the primary underground operations were concerned, almost entirely to safety matters. The industry had not harnessed to its help scientific research work nearly to the same extent that many other industries had done.

On nationalisation, the National Coal Board recognised that here was a gap, and a gap which must be filled. It divided this work into two parts: research work, and what we call 'scientific control'—the application of scientific methods to the day-to-day running of the industry. We still have those two main branches of our work.

### Shortage of Staff

The building up of the scientific staff was not easy. As you know there was, and still is, a dearth of men of science, and the building up of the organisation was therefore difficult at first, because of this shortage, which we shared with practically all other industries.

We have now reached a stage where our expenditure is roughly £800,000 per annum on research work, and slightly over £1,000,000 per annum on the day-to-day scientific control. I am not suggesting that money expenditure is the proper measure of the success of any organisation. That depends on other factors, but the figures do give some indication of the growth of the employment of scientific men and the supporting technical staff.

I will deal first with our research work. A research station was established at Stoke Orchard. It was engaged both on preparation and on carbonisation problems, as well as on our underground problems. Towards the end of 1951 the Board established a second research station at Isleworth, which is dealing solely with research work relating to pit problems. Stoke Orchard is now devoted wholly to the treatment and processing of coal, carbonisation problems, etc.

We aim at having a staff at each of these stations of about 350, and of these probably something of the order of 80 will be men of science, with a supporting staff of good technicians of some 100 or so. We are approaching those figures and have about 300 at each establishment.

### Fundamental Research

We are not excluding fundamental research. There is always a danger of an industrial organisation concentrating on the application of science, rather than the discovery of fundamental principles, and we are seeking to hold the balance between the two. There is a growing appreciation among industrialists generally of the importance of fundamental research. . . .

It is no good evolving ideas in the laboratory, or getting to the pilot plant stage, unless you have effective arrangements for developing those ideas and applying them further. We have decided to build a large central engineering establishment, not with the intention of going into competition with the producers of machinery, but because we want to translate our ideas into prototype machines and there is delay in getting that done at the present time. We have discussed this matter with the manufacturers of mining face machinery and they have, without any qualification at all, agreed that that is a proper thing for the Board to do. We are seeking at the moment the proper man to take charge of the establishment, and hope shortly to make an appointment. . . .

We are not neglecting the investigation of human problems, as distinct from fuel research and research into mechanical problems. In collaboration with the Medical Research Council and with Oxford and Cam-

bridge Universities, we have got field work and researches started on the terrible disease of pneumoconiosis. We want to know what type and size of dust is causing the disease. It has been suggested that development of the disease in a human being is much worse if tubular infection is present. The universities and the Medical Research Council are experimenting on questions of that nature with animals.

The Scientific Control service now devotes a good deal of its time to dust counts, in connection with pneumoconiosis, and our research people are seeking to develop automatic machines for dust recording. We are studying too, with the assistance of the universities, the question of the effect of humid conditions and high temperatures on the workers, because we are likely to have to go, in the future, to increasing depths of working, where questions of humidity and temperature will become even more important than they are in our present workings.

#### Dr. Townend's Address

Dr. Townend said that he was happy to follow Sir Hubert, as the National Coal Board was the principal supporter of his own organisation.

The problems of coal utilisation in industry which, including collieries, absorbed over 60,000,000 tons per annum, were mainly related to steam raising; this provided the largest category of coal consumption in the country. Prior to the war, more or less free choice of grades was available, but at present choice was restricted owing to general shortage. Furthermore, as already indicated, mechanised mining, and the working of more difficult seams, was tending to produce more small coal.

A national need, therefore, had arisen for a scientific appraisal of the influence of various characteristics of coal supplies on boiler performance; and this had been undertaken by BCURA since 1948. The variables studied involved the influence of rank, size, moisture content, ash content and coking properties on the overall performance of boilers; the task had now been completed and the results published in so far as the chain grate stoker was concerned.

In the field of water-tube boilers, Dr. Townend referred briefly to some of the operational difficulties which had been encountered in the past due to combustion

problems arising from the inorganic constituents of coal; these were mainly concerned with the formation of deposits on superheater tubes and the corrosion of air heaters.

Attempts at a more complete understanding of the chemical mechanisms operative under the conditions concerned had been pregnant with scientific interest. A high sulphur content of coal affected mainly the corrosion problem; for if the outlet flue gases had a high acid content, their temperature could not be reduced below the dewpoint without risk of corrosion; and a reduction in exit temperature of 16° corresponded with a gain in efficiency of 1 per cent. The alkali content of coal appeared to be mainly responsible for the formation of the difficult deposits; and their accumulation affected both heat transfer and gas flow. They had also been found to depend on the conversion of sulphur to sulphur-trioxide during the combustion process, and on metal surfaces.

Dr. Townend concluded by reference to the great need for more fundamental research into the constitution of coal itself; for a better understanding of our basic fuel underlay improvements in almost every field of its utilisation. In the past, attacks had been made first by the chemist, then by the geologist and today by the physical chemist. Coal was not just a black solid; it was a most fascinating material possessing a vast internal pore structure providing an internal surface of 2-20 acres/pound. Indeed, anyone watching coal burning on a fire, would note that individual pieces frequently retained their shape until they had been some 70 or 80 per cent consumed; this was due to the interesting fact that the pieces burnt internally as well as externally.

#### More Intensive Study Needed

A better understanding of coal, however, needed more intensive study by those having expert knowledge in cognate scientific specialisations; because of the difficulties involved, its elucidation had not in the past attracted many academic workers. The development of the petro-chemical industry had, in the popular mind, led to the dispraise of its coal counterparts; but by comparison, the chemical constitution of oil from whatever source, had always been simple, quite apart from the fact that coal possessed a complicated solid structure.

Answering W/C. E. A. A. Shackleton.

M.P., in the ensuing discussion, Dr. Townend said that even with smokeless fuels one could not do away with the sulphur content of the fuel, nor even was oil immune from this defect. Dr. G. E. Foxwell said that if carbon was not present the sulphur would be much less virulent.

Professor J. D. Bernal endorsed the remarks made about the need for fundamental research, particularly the lack of work done in universities hitherto. There was no Chair of Geochemistry in this country. In reply to a question by Professor Bernal, Sir Hubert said they were exploring the possibility of removing sulphur from coal, which was a very difficult problem. He agreed that the absence of a Chair of Geochemistry was a serious gap.

## Annealing of Copper Strip

### G.E.C.'s New Furnace at I.C.I. Works

A NEW 275 kW vertical cylindrical furnace, installed by The General Electric Co. Ltd. for the bright annealing of copper strip at the Kynoch works of Imperial Chemical Industries Ltd., is capable of handling charges weighing up to three tons.

The furnace is of a type developed by G.E.C. and now widely used for the processing of coiled ferrous and non-ferrous metals in controlled atmospheres. The charge is placed in a sealed container and is maintained in a controlled atmosphere throughout the process.

Economic use of power is obtained by a

system of heat recuperation whereby as the container and its charge are removed from the furnace their heat content is used to pre-heat newly charged pots. The installation at the Kynoch works of I.C.I. has forced air circulation to speed this transfer of heat and to give effective heat recuperation even at comparatively low temperatures.

Several containers, each more than 3 ft. in diameter and more than 12 ft. in length, are used to permit a continuous cycle of operations during which the charge is maintained in an atmosphere of cracked and burnt ammonia. To ensure uniformity of treatment, the atmosphere is circulated over the charge by a fan fitted to the lid of each container. The charge may consist of two or three coils which are stacked one above the other. Special handling gear is used to up-end the coils on to perforated carrier plates.

### OCCA Ladies' Night

The annual Ladies' Night organised by the London Section of The Oil & Colour Chemists' Association, and held at the Criterion Restaurant, Piccadilly Circus, W.1, on Friday, 4 December, was again a very successful and enjoyable function, and the attendance was a record. The members and their guests were received by Mr. R. F. G. Holness, B.Sc., A.R.I.C. (the chairman of the Section) and Mrs. Holness, and by Mr. H. Gosling, A.M.C.T. (the president of the Association) and Mrs. Gosling; and after dinner there was dancing until a late hour.

*General view of the new 275 kW installation at the Kynoch Works of I.C.I. for the bright annealing of copper strip. The equipment was supplied by The General Electric Co. Ltd.*

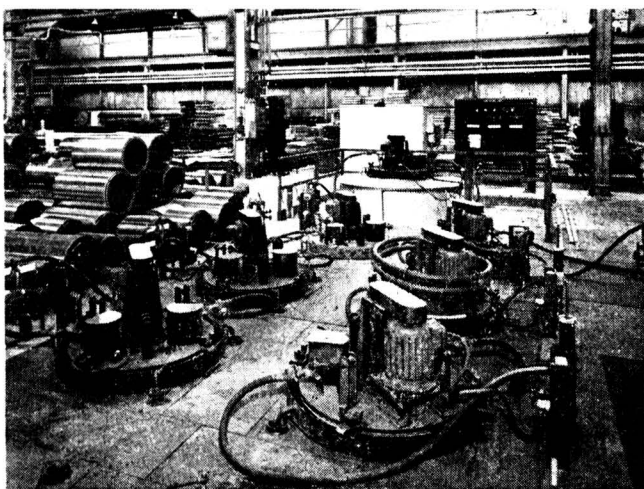

# The Complete Synthesis of Cortisone

## Industrial Production Now Possible

**I**NTEREST in the total synthesis of steroids has been widespread since Win-daus and Wieland first elucidated the structure of the cholesterol and cholic acid groups in 1932. The first success came in 1939 to Bachmann, Cole and Wilds, who obtained equilenin from Cleves acid in 23 steps; and nine years later œstrone was synthesised by Anner and Miescher from decalin.

Apart from their great importance in medicine, the hormones of the adrenal cortex have been particularly challenging to organic chemists in view of the unusual oxygenation at the 11-position. Following the discovery of the remarkable properties of cortisone (17-hydroxy-11-dehydrocorticosterone, Reichstein's Compound E) in the treatment of arthritis, interest has centred in the synthesis of this substance, and the subject has become one of commercial importance.

The only abundant steroids in nature are de-oxygenated at the 11-position, and chemical methods have been devised for the transformation of  $\Delta^2$ ,  $\Delta^{5,7}$  and 12-COOH steroids into suitable intermediates. Recently direct bio-oxidation procedures, employing *Rhizopus nigricans* or *Aspergillus niger*, have been developed.

### Major Industrial Moves

The first major move in the commercial exploitation of cortisone came last year, when the Monsanto Chemical Co. in America obtained a \$18,400,000 certificate for the erection of a plant to manufacture the hormone. This August the company applied for patents on a complete synthetic method using toluene as a starting material.

Since the content of these patents is not yet public property, the ensuring description is, in some degree, conjectural, but it is based on already published papers and on communications released by the researchers in the Monsanto laboratories.

The first stages of the synthesis involve an orthodox conversion of toluene to toluquinone, by nitration, reduction to *o*-toluidine, and careful oxidation (with  $MnO_2$ , for instance) to the quinone.

The ensuing 13 steps were des-

cribed by Woodward in his most important paper on 'The Complete Synthesis of Steroids' (*J. Amer. Chem. Soc.*, 1952, **74**, 4223). The principal difficulty encountered in building up steroid structures is the complication due to the presence of asymmetric carbons. For instance, the presence of nine such centres in cholesterol means a possible 512 stereoisomers, of which only one is the naturally-occurring substance.

### Complete Configuration

Fortunately, the complete configuration of cortisone is known, and the problem is resolved into discovering a means of fusing the rings in the correct steric relation.

Acetylation of toluquinone yields 2,4,5-triacetoxytoluene, which gives the 2,4,5-hydroxy compound on hydrolysis with sulphuric acid in methanol. Treatment with aqueous ferric chloride provides the 4-hydroxy quinone: the hydroxyl is protected by methylation, and coupling with butadiene in benzene solution gives *cis*-1,4-diketo-2-methoxy-10-methyl- $\Delta^{2,6}$ -hexahydronaphthalene (I). These two rings are destined to be rings C and D in the cortisone skeleton, and in this case the configuration should be *trans* (II). Caustic soda in dioxan will promote the rearrangement and seeding with a little of the *trans* product will cause the reaction to go to completion.

This is the first steric problem solved. Reduction with lithium aluminium hydride gives the dihydroxy derivative (III), which on demethylation with dilute sulphuric acid in dioxan yields 1-hydroxy-2-keto-10-methyl  $\Delta^{3,6}$  hexahydronaphthalene (IV). The remaining hydroxyl is removed by acetylation followed by zinc dust reduction to give 2-keto-10-methyl- $\Delta^{3,6}$  hexahydronaphthalene (V), which is then coupled with ethyl formate to give the 1-hydroxymethylene derivative (VI).

Ethyl vinyl ketone adds on in the presence of potassium *tert*-butoxide to give the 1-formyl-1- $\gamma$ -ketopentyl derivative (VII) and ring closure is effected by potassium hydroxide in aqueous dioxan, giving 1,14-dimethyl-2-keto- $\Delta^{1(11),6,9}$ -octahydrophenanthrene (VIII), which has come to be known as Woodward's tricyclic ketone.

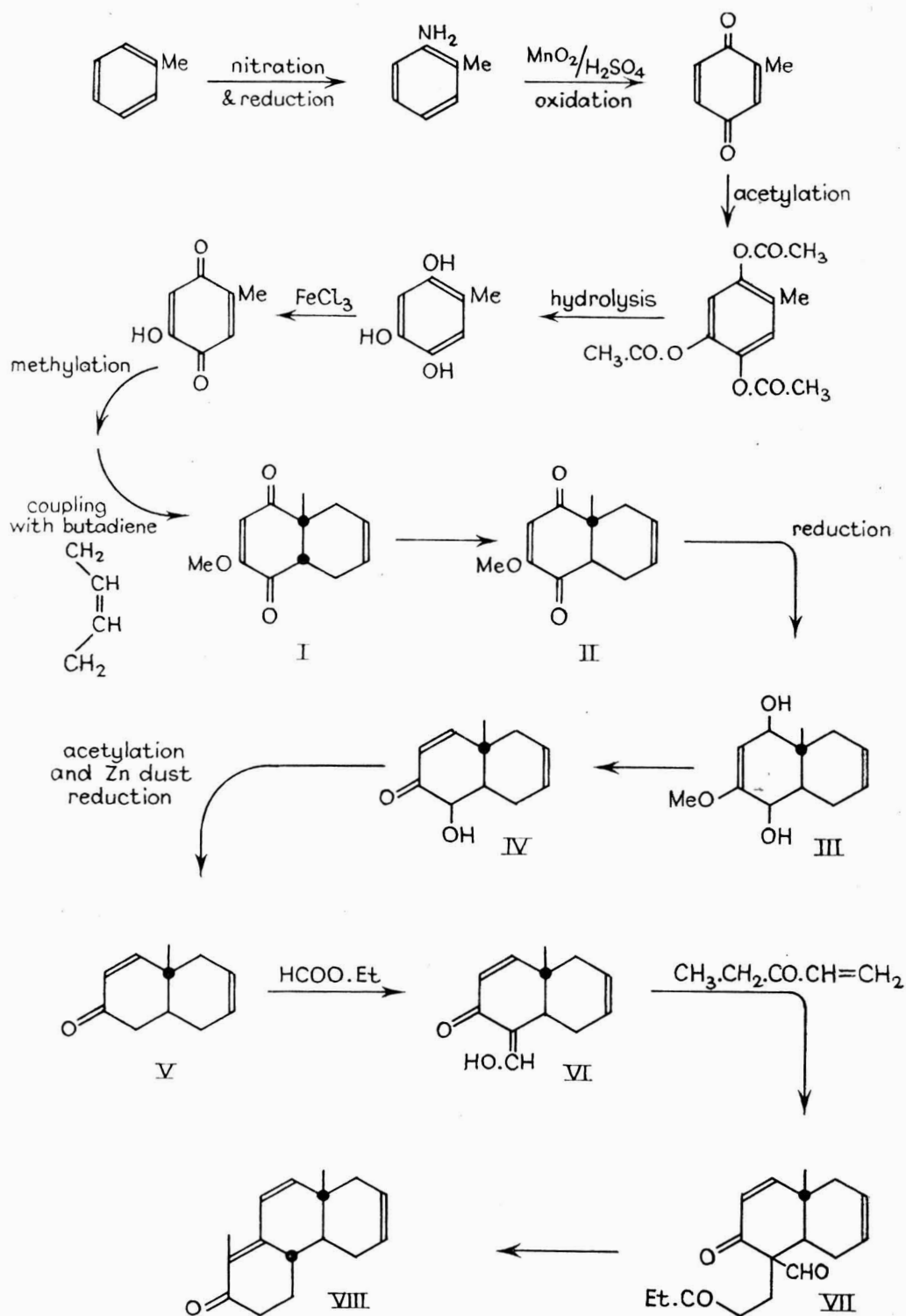

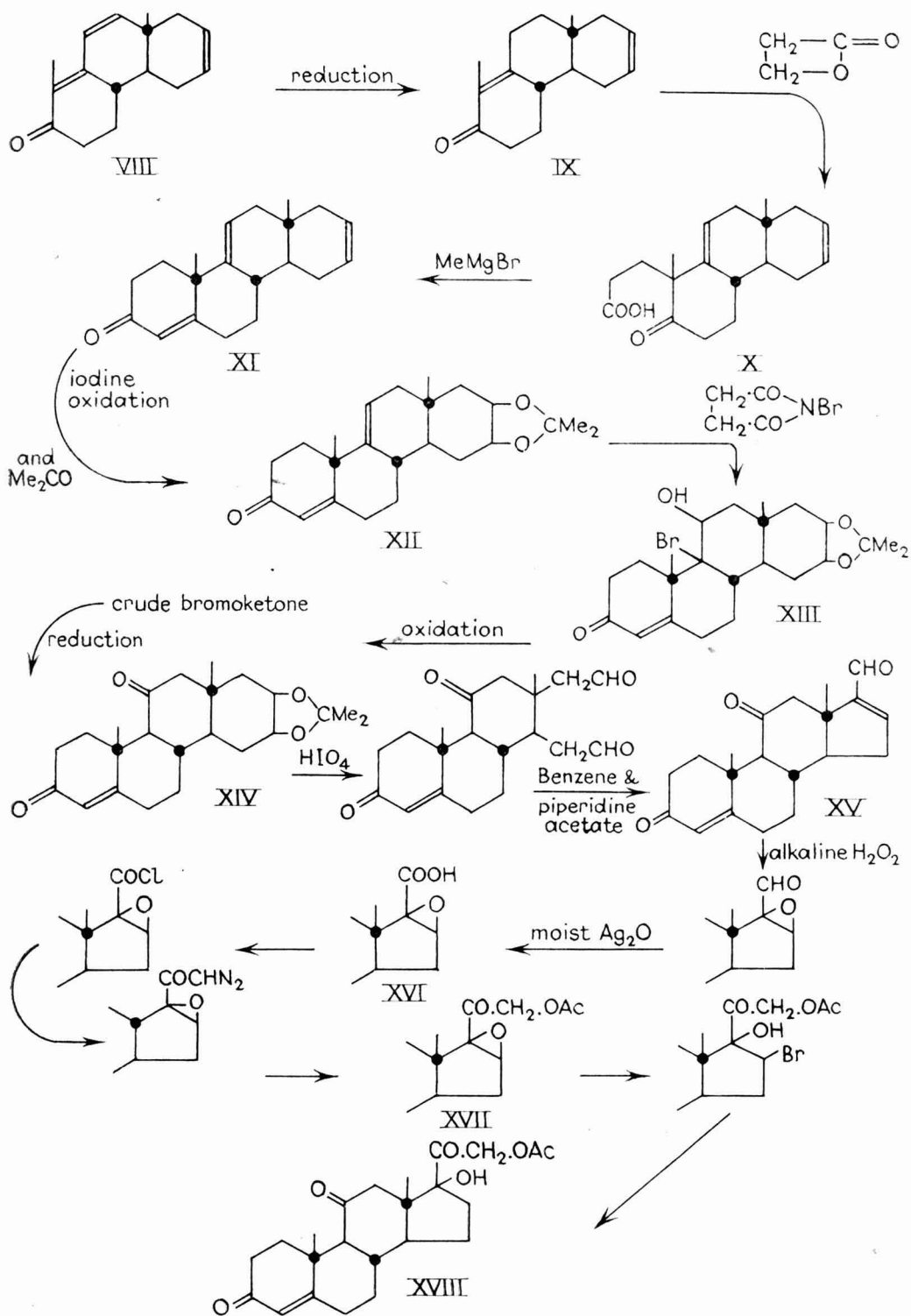



Woodward showed that this substance was a suitable starting point for a whole range of steroids, including cortisone, which could be reached in 37 synthetic steps. A recent paper from the Monsanto research laboratories, however, (Barkley *et al.*, *J. Amer. Chem. Soc.*, 1953, **75**, 4110) outlines a procedure involving only 17 steps.

Reduction of the tricyclic ketone with hydrogen, using palladium supported on strontium carbonate as catalyst, gives IX; the 3-position is blocked by the methyl-anilinomethylene derivative, and treatment with  $\beta$ -propiolactone in an ethereal solution of potassium amide gives 1-( $\beta$ -carboxyethyl)-1,14-dimethyl-2-keto- $\Delta^9$ ,<sup>10</sup> decahydrophenanthrene (X). This readily forms the enol lactone, which is treated with methyl magnesium bromide, and on cyclisation the product is XI.

The cortisone skeleton is now stereoisometrically complete, and the interest of the succeeding steps lies in the fact that the cortical side chain and 11-oxygen are introduced without the need to protect the  $\alpha$ - $\beta$ -unsaturated ketone in ring A.

Oxidation with iodine and silver acetate in dilute acetic acid provides the  $\beta$ -*cis* glycol, from which the acetonide XII is obtained. This is 3-keto-16 $\beta$ ,17 $\beta$ -dihydroxy- $\Delta^{4,9(11)}$ -D-homoandrostadiene acetonide, and it was proved by conversion to  $\Delta^9(11)$ ,<sup>16</sup>-21-*nor*-progesterone.

#### Introducing Five-Membered Ring

Treated with N-bromosuccinimide and sulphuric acid in aqueous acetone, XII gives 3-keto-11 $\beta$ ,16 $\beta$ ,17 $\beta$ -trihydroxy- $\Delta^4$ -9 $\alpha$ -bromo-D-homoandrostene acetonide (XIII). This is oxidised with chromium trioxide in pyridine to a crude bromoketone, which is left in solution and reduced directly to the 3,11-diketo compound (XIV). Periodate oxidation opens ring D, and it is closed again to a five-membered form (XV) with piperidine acetate in benzene solution. XV is 11-keto- $\Delta^{16}$ -21-*nor*-progesterone.

The remaining steps are concerned with the introduction of the cortical side-chain and the cortisone 17-hydroxyl. Treatment with alkaline hydrogen peroxide gives the 16 $\alpha$ ,17 $\alpha$ -oxido derivative, and oxidation of the aldehyde group with moist silver oxide gives 3,11-diketo-16 $\alpha$ ,17 $\alpha$ -oxido- $\Delta^4$ -etiocholenic acid (XVI).

Reaction of the dry sodium salt with oxalyl chloride provides the acid chloride,

from which the crystalline diazoketone is obtained by diazomethane. Hot acetic acid gives 16 $\alpha$ ,17 $\alpha$ -oxido-3,11,20-triketo-21-hydroxy- $\Delta^4$ -pregnene acetate (XVII); the oxidó ring is opened with hydrogen bromide, and reduction with Raney<sup>\*</sup> nickel gives the final product XVIII, *dl*-cortisone acetate, proved by its IR spectrum.

No figures have been given for the overall yields obtainable, but Woodward quoted figures for the overall reaction toluquinone  $\rightarrow$  VIII of about 25 per cent. Monsanto obviously consider that synthesis of cortisone is a commercial proposition, particularly in view of the shortage of suitable naturally-occurring steroids as starting materials. Whatever the outcome, the importance of this work, from the chemical, medical, and industrial points of view, is without question.

### Appeal for Equipment

A LETTER signed by Mr. T. Drummond Kerr, president of the Borough Oil & Colour Students' Association, appealing for funds to equip a paint testing laboratory in the new building of the Borough Polytechnic, London, was circulated recently and at a meeting of the committee last week it was reported that of the £2,000 target, £1,288 had so far been received.

The list is not yet closed, but the committee, which consists of representatives of the Society of British Paint Manufacturers, the London Colour, Paint and Varnish Manufacturers' Association, the London Section of the Paint Manufacturers & Allied Trades Association and the Oil & Colour Chemists' Association, expressed satisfaction with the response. Further contributions will be gratefully received by the secretary of the Borough Polytechnic, Borough Road, London, S.E.1, cheques to be made payable to the Borough Polytechnic.

#### Uranium Found in Cornwall

A Geological Survey team, which has been carrying out explorations on behalf of the Ministry of Supply for some time, has found uranium deposits at Altarnun, near Launceston, and on the edge of Bodmin Moor. It is not yet known whether the deposits are of economic value.

# Detection of Traces of Oxygen

## A New Instrument for Industrial & Laboratory Use

**D**URING recent years many industries have sought a practical and accurate means for detecting and measuring small quantities of oxygen present as an impurity in other gases. Traces of oxygen in sintering atmospheres have frequently remained undetected, with consequent substantial losses due to spoiled product. Minute quantities of oxygen in the atmosphere of heat treating and welding furnaces have resulted in impaired quality, especially when working with stainless and other alloy steels. Slight oxygen impurity in the gases used for filling vacuum tubes and lamps has caused costly spoilage. These and many other instances have stimulated both users and manufacturers of industrial gases to seek a practical and reliable method for detecting and measuring traces of oxygen.

The new Deoxo Indicator, made by Baker Platinum Ltd., manufacturers of the Deoxo Catalytic Gas Purifier, has been specially designed for this purpose. Ruggedly constructed and capable of operation for long periods with little or no attention, the instrument is suited both to industrial and to laboratory use. It indicates the presence of from 0.001 per cent to 1.0 per cent oxygen in inert gases, hydrogen, nitrogen, carbon dioxide and saturated hydrocarbon gases. The accuracy of indication is conservatively estimated at  $\pm 2$  per cent of the value of full scale reading.

### Operation of the Indicator

The principles of operation are very simple. Except in cases where the gas being tested already contains sufficient hydrogen, a small amount of this gas is generated in a self-contained electrolytic cell and mixed with the sample. After passing through a drying chamber and an activated charcoal purifier the sample enters a calorimeter containing a catalyst. During passage over the catalyst, combination of any oxygen with the hydrogen is effected.

The heat liberated is directly proportional to the concentration of oxygen in the sample, provided the amount of hydrogen present or added is in excess of that required to combine with the maximum percentage of oxygen which the indicator will measure. A

thermopile, with the cold junction located in the gas stream ahead of the catalyst and the hot junction located in the gas stream emerging from the catalyst chamber, indicates the temperature rise in the gas.

There is a straight line relationship, within the range of the instrument, between the voltage generated by the pile and the per cent oxygen present. By means of a sensitivity control, the instrument reading for a given per cent O<sub>2</sub> may be varied over a wide range. By reversing the electrolytic cell circuit, whereby excess quantity of oxygen instead of hydrogen is introduced into the sample, the instrument may be modified to detect and measure small quantities of hydrogen impurity in other gases.

### Easy Recalibration

Since the activity of the catalyst might change over a long period, a means for easily recalibrating the instrument is provided. For purposes of calibration, the test gas, after excess hydrogen has been added, is diverted through a separate catalyst chamber so that all oxygen present is removed by reaction with the hydrogen. Oxygen is then added at a measured rate, generated at a third electrode in the electrolytic cell, the rate of generation being regulated by measuring and controlling the electrolysis current. Since the rate of flow of de-oxygenised sample gas is indicated by a flowmeter and since the oxygen<sup>o</sup> is added at a known rate, the percentage of oxygen may readily be calculated and the galvanometer reading thus directly translated into per cent oxygen.

When required, the Deoxo Indicator can be furnished with a recorder or alternatively a potentiometer-recorder and controller.

---

### Silicones in Scotland

A demonstration of the potential scope of silicones in industry and commerce was staged in Glasgow last week. Shown in polishes, as water repellants and in a wide range of other uses, silicones are to be promoted extensively in Scotland. Arrangements have been made for their production by I.C.I. Ltd. at Ardeer, where plant is being laid down for the purpose.

# Rigid PVC & its Applications

## Important Material in the Construction of Chemical Plant

THROUGHOUT the world the consumption of vinyl materials is increasing as rapidly as manufacturing capacity can be expanded. By the beginning of next year the production of PVC raw materials in Britain will have increased some ten-fold since the war; yet demand continues to exceed supply. The output of PVC products has expanded as well; for example, the production of PVC sheeting is sixteen times larger than in 1946, and reports that new calenders are still being installed suggest that expansion in this branch of the industry is by no means ended.

It was as a flexible material that this versatile plastic first became well-known. Germany during the war was the first to appreciate the value of unplasticised or rigid PVC and her immediate neighbours were not long in following this lead. Latterly, however, countries outside the continent of Europe have taken increasing interest in the potentialities of rigid PVC which is now rapidly coming to the fore throughout the world as a material of construction.

Compounded without a plasticiser, PVC possesses in an enhanced degree many of the valuable properties associated with the flexible grades, such as low inflammability, low flame spread, and outstanding resistance to corrosion. For example, plasticised PVC may be attacked by concentrated acids and alkalis and the plasticiser may be extracted by most organic solvents, but unplasticised PVC is only affected by ketones, esters, cyclic ethers, nitro compounds, and chlorinated solvents. At sub-zero temperatures unplasticised PVC becomes brittle, but this tendency is insignificant until  $-40^{\circ}$  is reached. For most purposes the material should not be used without mechanical support at temperatures above  $60^{\circ}$ , as it can then flow if under sufficient pressure.

### May be Turned, Drawn or Moulded

Below the solidification region, unplasticised PVC may be turned or drawn. In the production of electric cable aluminium and even copper can be cold drawn from rod of 0.5 in. to wire of 0.05 in. with a rigid PVC sheath. The cables so formed may be severely deformed by rolling, swaging and

pressing, without any change in the mutual position of conductors, insulation and sheath, since the combination of copper or aluminium and PVC behaves like a uniform metallic body.

At temperature ranges above the solidification region but below the flow region, unplasticised PVC may be formed by free blowing, blow moulding, and compression moulding. In this temperature region the material tends to recover after the deforming pressure is discontinued at the same temperature, since the deformation is partly elastical and internal stresses therefore remain. The closer to the flow temperature, the smaller is the percentage of recovery. Calendering and extrusion are therefore performed exclusively at temperatures well above the flow temperature.

### No Surfacing Required

By passing the softened sheet over formers 'deep drawn' articles which are both strong and dimensionally stable are produced. The sheet is moulded at temperatures of only  $100-160^{\circ}$ , no surfacing being required.

Processing rigid PVC above the flow point presents special difficulties, because this material has a much higher internal friction than plasticised compounds at the same temperature. It could be rendered as flowable as plasticised PVC by the application of higher temperatures, but this solution is impracticable when conventional machines are used, because PVC decomposes if held for more than a few minutes at temperatures above about  $200^{\circ}$ . This limitation has been overcome by the development of machines so designed that the processing time is restricted to seconds instead of minutes, thereby enabling temperatures up to  $300^{\circ}$  to be applied without the slightest trace of decomposition.

Under all normal conditions unplasticised PVC is very stable, the maximum linear change in dimensions being as low as 1.0 per cent within the temperature range from below freezing point to  $50^{\circ}$ .

Unplasticised PVC can be machined by most of the standard processes used in the woodworking industry. It can be stuck to

itself and to other materials such as paper, fabrics or wood by means of special cements. Rigid PVC components are readily assembled and jointed by welding, thus enabling the material to be used for the fabrication of very large items of chemical plant. At present the techniques most commonly used are hot air welding, heat element welding, friction welding, and HF welding. Hot air welding is a valuable method of joining two rigid PVC parts to one another, particularly in the case of butt or angle welds, where the surfaces to be joined are relatively small in area.

#### Various Sizes of Piping

Unplasticised piping is extruded by British firms in sizes ranging from  $\frac{7}{8}$  in. to  $1\frac{1}{4}$  in. dia. with varying wall thickness; piping up to 6 in. dia. or larger can be extruded if desired. Due to its chemical resistance, which is superior to that of stainless steel in many applications, it has a much longer life than ordinary steel piping. Because of its proven superior physical strength and outdoor ageing properties over those of other rigid plastics, it shows comparable superiority in operational performance.

Another important advantage of rigid PVC piping is that it is less than one-fifth the weight of steel piping, with consequent saving of transport and assembly costs. It is also considerably easier to install, since it can be flanged, screwed, or fitted with slip-fit joints produced on site. If slip-fit joints are used these can be made tight merely by wetting with a solvent, thus saving both time and labour. Bends can be produced on site by heating the pipe to approximately  $80^\circ$ , the blow-pipe being held in such a position that the flame does not reach the pipe. Factory produced shapes can be supplied. Further savings result from the smooth interior finish of PVC pipe, which reduces the frictional resistance to fluid flow, thus permitting smaller diameter pipes to be used without any decrease in flow.

An estimate of the 'short time' bursting pressure of rigid PVC tubing can be obtained from the following formula:—

$$\text{Bursting pressure} = \frac{2 \times \text{tensile strength} \times \text{wall thickness}}{\text{Inside diameter}}$$

When pipes are subjected to pressures for long periods the bursting strength is lower than that calculated by the formula given

above and, consequently, suitable safety factors have to be applied.

When calculating required bursting strength for free-standing piping to operate at ordinary temperatures, it is usual to allow a safety factor of 4:1. Rigid PVC piping may, however, be employed at higher temperatures as a lining inside a steel pipe. Here, of course, the operative bursting strength is that of the supporting steel, and the temperature in service may rise even above the softening (flexible) point of the PVC without giving trouble.

The plating industry in Britain is lining its tanks and other equipment with rigid PVC as a protection against the corrosive action of plating solutions and acid fumes.

Unplasticised PVC is extensively used on the Continent for water mains, chemical piping, conduit and waste pipes. From the United States come reports of a new rigid vinyl piping, capable of handling corrosive chemicals at 500 psi. working pressure ( $25^\circ$ ) which has been produced by Kralog Plastic Pipe Co., Inc. It can be used for the transmission of practically all chemicals, including oxidising agents up to  $85^\circ$ . In Italy rigid PVC piping is replacing sandstone piping because of its superior oil and chemical resistance. These pipes are extruded in diameters up to 15 in. with wall thicknesses up to almost  $\frac{1}{2}$  in. The production of rigid PVC piping has only recently been undertaken by the British plastics industry; now that this piping has become available it is making rapid headway and a substantial increase in demand is foreseen.

Rigid plastics sheets based on Geon PVC are being used in California to line a sewer pipe nearly seven miles long. The purpose of this lining, for which some 400,000 sq. ft. of plastic will be required, is to prevent disintegration of the concrete caused by the oxidation of hydrogen sulphide.

#### Combination Sheet

Another interesting development is the introduction of a combination sheet comprising a rigid PVC sheet about  $1/16$  in. thick, to which is adhered a plasticised sheet of similar thickness. The latter serves as a flexible backing for the rigid PVC sheeting, which is in contact with the liquid in the tank. An important advantage of this arrangement is that plasticised PVC is bonded to metal more readily than rigid

PVC, adhesion being obtained without the use of heat.

Unplasticised PVC is finding increasing applications not only as tubing and in foil or sheet for protective lining, but also in the form of self-supporting constructional parts for chemical apparatus. Pickling cabinets are now being made in Britain entirely from rigid PVC, the pipe and tube connections and even the valves being manufactured from the same material. Hitherto, one of the principal obstacles to the production of pickling or plating plants, which must be fully corrosion-resistant throughout, has been the difficulty of finding a satisfactory material for the joints. Experiments are now being made with all-plastic couplings and with nylon nuts and bolts, so that the whole of the piping can be immersed.

#### Manufacturers Experimenting

Some manufacturers are experimenting with the use of rigid PVC for duct fabrication, thus avoiding the necessity for lining metal ducts with corrosion-resistant materials. The larger items now being fabricated in this versatile plastic include absorption towers and gas washing towers, rotary fillers, and a variety of tanks and deep trays. In Germany a large brick chimney stack some 270 ft. high was badly damaged by chemical fumes and repairs to the masonry would have been very costly. An economical solution to this problem was found by constructing a subsidiary stack about 18 in. diameter, which consisted of short cylindrical sections fabricated in rigid PVC.

Among the many smaller items now being produced in rigid PVC are refrigerator components, acid scoops, pickling and dipping baskets, fan impellers and casings, safety helmets for chemical workers, drip trays, and cooling coils.

Still a very young material industrially, particularly in the United Kingdom, unplasticised PVC is the subject of vigorous research and development programmes. Once chemical engineers have fully realised its possibilities, it is likely to be specified for applications demanding high resistance to atmospheric and chemical corrosion, combined with low inflammability and durability. The ultimate level of consumption is naturally difficult to estimate; one observer, however, places this at 100 times the present tonnage.

## Low Alloy Steels Analysis

AS part of a programme for standardising methods for the determination of elements in iron and steel, the British Standards Institution has published 'Recommended Method for the Spectrographic Analysis of Low Alloy Steels' (BS. 1121B: 1953). This is based on the work of the spectrographic analysis sub-committee of the British Iron and Steel Research Association, whose report has been published by the Iron and Steel Institute as special report No. 47, 'Spectrographic Analysis of Low Alloy Steels.'

The method provides for the excitation of the samples by means of a condensed spark discharge. A flat sparking surface technique is used, the emitted spectral radiations being dispersed by a large quartz prism spectrograph and recorded on a photographic plate. The internal standard method, in which the density of a chosen spectral line of the element being determined is compared with the density of a chosen iron line, is used to make an evaluation from the spectrogram. The comparison of the densities is made by means of a non-recording densitometer, and the percentage concentration of the element is finally obtained from a concentration calibration curve derived from the analysis of standard samples.

Copies of this standard (price 5s.) may be obtained from the British Standards Institution, Sales Branch, 2 Park Street, London, W.1.

---

#### Fire Protection

Eight comprehensive sections, each dealing with a particular phase of fire prevention or fire fighting, make up the 1954 edition of the *Fire Protection Year Book*, published by Benn Brothers, Ltd., Bouverie House, Fleet Street, London, E.C.4. Directories of public and other fire brigades, also salvage corps, are given, and one section is devoted to Commonwealth and Empire fire services. Government departments and public authorities concerned with fire prevention are listed, also organisations actively connected with or interested in fire prevention and fire fighting. The legal aspects of the subject are included and fire engineering data are given. Particularly useful is the comprehensive list of fire safety equipment suppliers.

## Anti-Static Rubbers

### New Standard for Testing Issued

THE British Standards Institution has published BS.2044:1953 covering laboratory tests for resistivity of conductive and anti-static rubbers.

Rubber is normally regarded as a material of high electrical resistivity; consequently it is widely used as an insulator. However, the incorporation of various materials, in particular certain forms of carbon black, reduces the electrical resistance greatly so that volume resistivities between  $10^{15}$  ohm-cm. and 1 ohm-cm. are obtainable.

There are various technical and industrial purposes for which rubber with a reduced resistivity is a useful material, the most frequent application being for the dissipation of static charges. In certain circumstances a lower limit of resistance value must be imposed on a product with this latter application, as a safety precaution to prevent its ignition or to prevent severe shock to a person in contact with it, in the event of faulty insulation of nearby electrical equipment.

Products which, while conducting away static charges, are sufficiently insulating to fulfil the safety requirements above are termed 'anti-static' rubbers. Products which do not fulfil the safety requirements are termed 'conductive' rubbers. Since the dimensions of the product are involved it is not possible to define a suitable range of volume resistivities for either of these classes, but only a range of resistance values between defined points. The principal hazard apart from static electricity in most buildings and with most electrical equipment is from leakage currents from normal voltage supply mains. To guard against these hazards it is recommended that the lower limit of resistance for an 'anti-static' rubber product should be  $10^5$  ohms.

### Considerable Variations

Under normal conditions of service with varying temperature and strain history the resistance of a sample of a given material can vary considerably, for example by a hundred or more times between strained material at room temperatures and material which has remained unstrained for a short period at 100°.

In order that valid comparisons may be made between test pieces a conditioning

treatment is specified so that the measurements shall be made on test pieces reduced to a constant strain and temperature condition.

The definition of a suitable electrode system is an important part of this specification, and in order to satisfy the various practical requirements for tests on laboratory prepared test pieces a variety of suitable electrode systems is given.

Copies of this standard may be obtained from the British Standards Institution, Sales Branch, 2 Park Street, London, W.1, price 2s. 6d.

## Abrasion Testing of Rubber

A NOTICE from the British Standards Institution states that it has been found that the results of abrasion tests carried out by the Du Pont method, described in BS. 903—'Methods of testing vulcanised rubber' and as adopted by Technical Committee 45—Rubber, of the International Organisation for Standardisation, are dependent on the quality and cutting power of the abrasive paper used.

The Minnesota Mining and Manufacturing Company, of Arden Road, Adderley Park, Birmingham 8, have been approached concerning the production of such papers and the particular requirement of constant cutting power has been discussed with them. They fully appreciate the importance of strict control of paper characteristics and they are prepared to supply a batch of paper with similar characteristics to those which have been tested and found satisfactory.

The manufacturers are prepared to manufacture a quantity sufficient for 10,000 Du Pont machine discs. These will be printed with normal marking as Tri-m-ite paper, Grade 180 E, with the additional words 'Special ISO batch' on the back.

It is suggested, therefore, that laboratories requiring test results to BS. 903 or in accordance with the agreement reached by ISO, which will be interchangeable and free from the difficulty of a change of abrasion index with life of paper, should obtain a consignment of this special batch by ordering from this manufacturer. The manufacturer has undertaken to reserve this batch exclusively for such orders, and has suggested that a reasonable minimum quantity would be 500 discs.

# Problems of Biochemical Engineering

## Maintenance of Sterility in Fermentation Processes

**R**EADING a paper to the Institution of Chemical Engineers in London on 8 December, Mr. J. J. H. Hastings, M.B.E., of The Distillers Co. (Biochemicals), Ltd., considered some of the biochemical engineering problems related to the newer fermentation industries. In these industries, he said, very large plants were used to produce micro-quantities of finished products such as vitamins and antibiotics, and problems had been introduced which did not arise in the older processes of brewing and yeast manufacture.

### Ten Questions

Referring principally to the experience gained in the preparation of penicillin, Mr. Hastings listed 10 questions whose answers a chemical engineer would require before preparing a flowsheet for industrial production:

(1) Would the mould grow and also produce penicillin in a deep layer of aerated liquid?

(2) How much air did the mould need for successful penicillin production, and what was the best way to distribute the air through the liquid? This was a problem of theoretical interest to the biochemist, but one of great practical and economic importance to the engineer.

(3) What method was employed for the sterilisation of the large quantities of air required? The basic methods were known to be heat, wet scrubbing, or dry filtration.

(4) Would mechanical agitation be necessary in addition to that provided by aeration, and if so, in what form?

(5) What materials of construction were to be employed for the fermentation vessels, and would they be subject to corrosive attack? It was known that traces of certain elements were inhibitory, either to the growth of the organism, or to the production of penicillin.

(6) What internal pressures would the vessels have to sustain (a) during steam sterilisation, and (b) during aeration of the medium throughout the fermentation?

(7) What means would be required to control the temperature within narrow limits? Cooling might be required when

the fermentation was proceeding rapidly, and heating in the early and later stages.

(8) What conditions of time and temperature were required for the sterilisation of plant and medium? Could a compromise be found between conditions giving a complete sterilisation and those in which components of the medium were unaffected? And what of the maintenance of sterility in joints, valves, thermometers and gauges?

(9) How could complete removal of the mycelium from the liquor be effected at the end of the fermentation? Could the biochemist co-operate by defining growth conditions under which the most suitable form of mycelium would be obtained?

(10) Were there likely to be any hazards, health problems or nuisances which the chemical engineer must guard against by suitable precautions or by plant design? What would be the nature of the effluent, and how could it best be disposed of?

Unfortunately there was no one answer to each of these 10 questions. Indeed, each time a new fermentation process was undertaken, they must be asked all over again. Although good standards of working practice have been established, much still remains to be achieved. It was proposed to discuss certain points which had received less attention than many in the literature, in particular the maintenance of sterility.

### Air Sterilisation

Heating is by far the most certain method of sterilising air, but it is the most expensive. At 300° all living micro-organisms are destroyed in a few seconds, and at temperatures a little higher death is almost instantaneous. A large holding vessel is therefore not required with air at these temperatures, but the air must be cooled before use in the fermenters. The design of an efficient heat exchanger for this duty is important.

Sterilisation by heat is used in small scale production units where electrical heating is usually preferred.

Some of the earliest penicillin plants employed wet scrubbing methods with only moderate success. The main difficulty lay

in wetting the organisms, which are as small as one micron, and a further difficulty was the danger of carrying forward an aerosol of disinfectant into the fermenter.

The most successful method of wet scrubbing has been to use porous elements for passing air into the liquid scrubbing medium. A depth of not more than two feet has been found the best for the porous elements which can be sintered carbon or metal, fused silica or quartz. There are, however, difficulties in the application of this method which still need to be overcome.

The porous elements must be robust to withstand frequent heat sterilisation. A fractured element which permits large bubbles to pass destroys the efficiency. At present the unit elements available are small in size and a very large number must be used in parallel. This complicates the design since each element has a critical air velocity.

#### Dry Filtration

Most manufacturers have now changed over to dry filters as the simplest and cheapest method of operation. Two types of filter are used, one packed with fibrous material such as cotton-wool or sintered slag-wool, the other with coarse materials such as a loose bed of granular carbon.

A minimum depth of three inches of slag-wool, and a maximum air velocity of 1 ft. per sec. are considered adequate conditions for the complete removal of micro-organisms from the air. The chief difficulty is to ensure that no air by-passes the filter, and accurate fitting is essential. Sintered slag-wool board cannot be sterilised by steam, which destroys its structure, and must be sterilised by dry heat.

The most usual practice with cottonwool filters is to build the material as a roll on a cylindrical wire mesh enclosed in an outer chamber. A firmly packed bed at least 6 in. deep is generally considered essential. Steam sterilisation can be employed, but the cotton-wool must not be allowed to become sodden.

In a coarse filter such as granular carbon, it is thought that direct adsorption of the micro-organisms takes place, since the interstices between particles are very much larger than the size of the micro-organisms. A bed of this type may be used for many hundreds of hours without re-sterilisation. The usual size used is in the range of 20-40 mesh.

Care must be taken that too great a pressure drop does not occur. This may be due

to the use of too fine a grain of carbon, or to a change in air flow from viscous to turbulent. The latter occurs when the air velocity rises above about 1.2 ft. per sec.

The first sterilisation can be a hazardous operation. A certain amount of fine carbon dust adheres to the granules, and spontaneous ignition may occur if sterilisation is commenced with steam under pressure.

The real test of efficient filtration is the behaviour of air in large-scale fermentations. Many air-sampling devices have been devised but none is satisfactory because of the limited volume of air used; the volume of air in which one organism must be detected is very large. There is no substitute for a full-scale working test, although it is costly and time-consuming.

The normal method for the sterilisation of the materials in the fermentation vessel, prior to the commencement of the process, is by steam at a temperature of 120° for 30 minutes. This is essentially a simple matter but is complicated when precipitates of insoluble compounds are formed in the fermenter. It is important that any crevices and pockets which trap these solids should be avoided in the design of the plant. All pipe lines must be arranged to drain completely and dead lengths of pipe, such as connections to gauges, must be avoided.

Universal practice is to supply steam to every pipe connection to the fermenter, maintaining full pressure to the valve. No non-sterile services such as plant-water should be allowed to remain in connection.

#### Sources of Infection

The greatest sources of danger are valve stems and the shafts of pumps and agitators. Completely satisfactory answers have not yet been found to these difficulties. Diaphragm pumps are theoretically sound, but in practice it is found that the diaphragm does not withstand the arduous conditions of sterilisation. Sterile liquids are seldom pumped cold, but are usually moved at full sterilisation temperature, the cooler being placed between the pump and the fermenter.

None of the individual problems outlined is incapable of solution, but it does mean that the chemical engineer in this major section of the biochemical industry must have not only an understanding of the delicate processes involved, but also a proper understanding of the behaviour of micro-organisms.



# Technical & Technological Education

## Rôle of Research Associations Discussed at Conference

THE rôle of the research associations in technical and technological education was the subject of a private conference held in London on 27 November. The Advisory Council for Scientific and Industrial Research attended, together with the chairmen and directors of the research associations and a few representatives of the universities and technical colleges.

Although the object of the conference was to review the educational work already being done by the research associations and to discuss whether more could or should be done, the discussion ranged more widely, as shown by the following notes.

Several speakers referred to the training of the graduate destined for employment in industry, during the first two or three years after graduation. It was suggested that it was better, in some cases, to extend the student's background by providing an appreciation of the technological problems of industry and of the application of research to their solution, rather than to encourage him to undergo the specialised training required to qualify for a Ph.D. degree at a university. This could be done by a period of training at a research association.

### Preference for Ph.D. Studies

Nearly all students receiving DSIR post-graduate awards prefer to remain at a university, it was stated, because, apart from one or two exceptional arrangements, this is the only way in which their work is, at present, eligible for a Ph.D. The universities show reluctance to depart from the principle that the Ph.D. can be awarded only for work done on university premises. Some speakers considered that too much importance was attached to this degree, but it was recognised that it is much sought after. The Ph.D., it was felt, should be reserved for students who have proved their aptitude for research and for successfully pursuing research studies in several subjects.

It was suggested that there were a number of ways in which the essential authority of the university could be preserved while allowing some post-graduate studies to be carried out in research association laboratories or elsewhere. Developments of this

kind were to be encouraged in the national interest. The opinion was expressed that university regulations for the admission of students for post-graduate work tended to be somewhat restrictive, and the conference thought that some relaxation would be in the interest of all.

Many professional institutions play an important part in establishing qualifications which industry regards as of degree standing. It was considered that this rôle might be further developed. These professional qualifications have merit as an alternative to the Ph.D., which is not always appropriate, and also possibly as first degree qualifications before university post-graduate studies.

### Post-graduate Survey Proposed

The conference thought that an estimate should be made of how many young people are receiving post-graduate training and of what becomes of them so as to help in determining the best type of training.

The research associations offer opportunities for vacation students. An appeal was made to the universities and the associations to ensure that the time spent was beneficial both to the student and the association.

The research associations have a wealth of new knowledge which could more often be made available to the training staffs in universities and technical colleges. Training staffs already draw upon this knowledge through research association publications and lectures. The idea of temporary attachment to the research association staff might be further explored. Not all industries, however, can afford to make their recent advances so widely available.

The discussions showed that there was scope for closer collaboration between the universities and technical colleges on the one hand, and the research associations on the other. It was urged that the responsible bodies concerned should consider this aspect further. As an interim measure it was agreed that the DSIR and the Ministry of Education should arrange for more information about the research associations to be available to the technical colleges and *vice versa*.

It was emphasised that technical colleges

now provide a wide range of courses, up to and including the post-graduate level. Some of these courses are given by lecturers from research associations and some are attended even by university professors. Mention was made of the need for greater emphasis on training for management if full use was to be made of science by industry, but it was suggested that industry was not yet fully exploiting university courses already available. Senior research association staffs have an important role to play, it was contended, as advisers on the educational needs of the industries they serve.

The importance of research association publications as an educational medium was referred to and the need to write these in terms that could be understood by the people who were to use them was stressed.

---

### *Complaints About Fumes*

A REPLY to complaints about fumes from Courtauld's rayon factory at Greenfield, was read at a recent meeting of Whitford Parish Council on 28 November. It was alleged at a previous meeting that the fumes were noticeable some miles from the factory. The firm's reply stated that they were very much alive to the trouble, but unfortunately the design and construction of the necessary plant to abate the nuisance presented a difficult scientific problem. A team of chemical engineers was permanently engaged in an attempt to find a solution, and their most recent work showed some promise of success. A scrubbing tower was being erected at the Greenfield factory, and it was hoped to have it in use by the end of the year. This equipment was intended primarily for the purpose of carrying out large-scale experiments in fume treatment, and the firm hoped that it would eventually lead to a process which could be applied to all their Flintshire factories.

---

### *Chemicals in Colombia*

THE past few years have seen a marked expansion of Colombia's chemical industry. Production of sulphuric acid is now more than enough to meet home demands and a modern plant at Betania is using the large salt deposits at Zipaquirá, north of Bogotá,

to produce large quantities of caustic soda, chlorine, soda ash, etc.

The sulphuric acid is produced at two different plants, while a plant near Cali is turning out sufficient sulphur to meet national requirements, although high-grade refined sulphur is still imported. A company in Bogotá, as well as the Government-owned plant at Betania, is producing chlorine, caustic soda, ferric chloride and soda ash. Two or three plants specialising in glycerin production are under construction or are being planned, while small quantities of acetic acid, methanol, acetone and wood tar are already being produced, also a small quantity of organic chemicals.

Despite these developments, the country still relies to a considerable extent on the importation of a wide range of chemicals, chief importers being the pharmaceutical, rayon and rubber tyre industries. There is also extensive reliance on outside suppliers for insecticides, fungicides and pesticides.

---

### **Q.V.F. Ltd.**

Q.V.F. Limited, a new company formed to market the 'Visible Flow' glass pipeline manufactured by James A. Jobling & Co., Ltd., and the 'Quickfit' industrial plant in glass of Quickfit & Quartz, Ltd., came into effective operation on 1 December.

The organisation includes a research and development department, under the control of Mr. J. McNicol Bruce, technical director. Here new ideas and designs will be evolved and proved under working conditions. This department will operate in support of chemical-plant design engineers and in collaboration with customers on specific problems, whether glass equipment plays a large or only small part in the final layout.

This new project in no way affects existing arrangements for marketing of 'Quickfit' interchangeable laboratory glassware by Quickfit & Quartz, Ltd.

---

### **Museum Pieces**

Four field medicines issued to British troops during the Crimean War have been added to the Pharmaceutical Society's historical museum. The bottles, labelled 'The British Pharmacy, Smyrna,' contain powdered rhubarb; milk of sulphur and cream of tartar; calcined magnesia; and ipecacuanha wine.



# The Chemist's Bookshelf

**ELECTROCHEMICAL CONSTANTS.** United States National Bureau of Standards Circular 524. Office of Scientific Publications, Washington. 1953. Pp. 310. \$2.

This book is a collection of papers presented at a Symposium on Electrochemical Constants held by the United States National Bureau of Standards in 1951. Thirty papers, three in abstract form only, are given and the authors are all well known in the field of electrochemistry. The term 'Electrochemical Constants' is used in a broad sense and a wide range of topics is covered making the book an authoritative survey of modern views on a variety of electrochemical subjects.

Three papers are concerned with the determination of the Faraday. One of them considers errors arising from inclusions in the silver of the silver coulometer. The others are concerned with the determination of  $F$  by oxidation of oxalate ions and by a new method involving finding the ratio of charge to mass using the cyclotron resonance condition. An extended Onsager equation for dilute aqueous solutions of electrolytes is given by Baker and Kraus, and the high field conductivity of paraffin chain electrolytes is considered by Gusman and Cole as a means of providing information regarding micelles.

Other papers are concerned with the determination of transport numbers by various methods including those involving the e.m.f.-centrifuge and moving boundary techniques. Harned discusses diffusion coefficients of electrolytes in dilute aqueous solutions. Four papers are concerned with standard cells; their ageing, the septa used in their construction and the unit of e.m.f. being considered. There are two papers dealing with thermodynamics, one discussing thermal diffusion of electrolytes and the other thermoelectric and thermomagnetic effects. There are contributions on half cell and standard potentials and a brief

account by Latimer of the use of potential diagrams in the interpretation of inorganic chemistry. Two papers are concerned with activity coefficients of electrolytes, one dealing with the effect of pressure. Scatchard contributes a comparison of methods of treating equilibria and reaction rates in dilute solutions of electrolytes.

There is a useful paper on the standardisation of the  $pH$  scale. Others include a discussion by Overbeck on constants involved in the treatment of electrical double layers, a contribution by Ferguson on the mechanism of overvoltage, a review, well documented with references, of parameters of electrode kinetics by Bockris, and a survey of electrokinetic work in capillary systems and colloidal solutions by Rutgers and De Smet. An extremely interesting paper on e.m.f. from proton transfer reactions is contributed by Shedlovsky and Muller discusses a correction factor for the Ilkovic equation in polarography.

All those engaged in electrochemical research will find much to interest and stimulate them in this book, and teachers of honours degree physical chemistry much useful summarised information. Not the least interesting parts of the book are the discussions following each paper.—W.R.M.

**PHYSICAL CONSTANTS OF HYDROCARBONS.** Volume V. By Gustav Egloff. Reinhold Publishing Corporation, New York. 1953. Pp. x + 524. £8.

Considerable progress has been made in the chemistry of hydrocarbons since the first of this series of American Chemical Society Monographs was published in 1939. Developments in the techniques of structural analysis, and in methods of synthesis, have necessitated the revision of certain structures and have enabled others to be ascertained with greater precision than was possible previously. These advances, together with the vast array of fresh determinations made on well-characterised com-

pounds, have rendered the earlier volumes considerably out of date, and the present volume is really a revised version of Volume I.

It deals with paraffins, olefines, acetylenes and other aliphatic hydrocarbons, and should prove invaluable to workers in the petroleum industry. It covers all papers recorded in *Chemical Abstracts* before September, 1951, together with later papers in the leading American, British and Russian journals. As compared with Volume I, there are some minor changes in nomenclature and in the method of expressing variation of boiling point with pressure; when warranted by the data available, the Antoine equation is now used, because of the wider pressure range over which it is applicable. The book is a detailed catalogue compiled by a specialist for other specialists.—E.J.B.

**MICROSCOPY FOR CHEMISTS.** By H. F. Schaeffer. D. van Nostrand Company Inc., New York; Macmillan and Co., Ltd., London. 1953. Pp. 264 + viii. 34s.

This is a rather disappointing book. Most existing information on the use by chemists of the microscope occurs either in advanced textbooks or as a section in books dealing with instrumental methods of analysis in general. There is room for a single textbook which would act as an introduction for the chemist who feels that he could usefully apply the microscope, but who does not wish to delve too deeply into the more complex parts of optical crystallography. There is a wide variety of methods available to such a worker. Consequently, working from the title, the reviewer approached this book feeling that it might meet the requirements. Regretfully it must be decided that this is not so.

The first half of the book presents a theoretical treatment, and the second half is devoted to a practical course based on this. In many places the theoretical treatment is muddy and inadequate. Space is wasted in dealing with elementary principles, such as the nature and behaviour of simple lenses or the phenomena of refractive index, which might safely be assumed either to be a part of the knowledge of the worker, or to be readily available to him in an elementary text-book of physics if he really felt in need of the information. Even so, the treatment is often rather confusing.

Where the topics are at all difficult of presentation several existing works can be thought of where the treatment is much clearer; and usually insufficient of this more advanced matter is given to be of much value. It is true that the author points out that 'the specialised technique of optical crystallography is not within the province of this brief work.' But some sort of treatment is essential, and the amount given here is quite inadequate. Again, the actual measurement of refractive index ought to have been treated more rigorously, since this is one of the most important simple operations in chemical microscopy. Valuable procedures such as the recently developed examination of the crystallisation of organic compounds from the melt are ignored.

The choice of some of the experimental matter is open to question. Although a worker may require to understand the relation of numerical aperture to the optical behaviour of an objective, few users of the microscope as a simple analytical tool might expect to require to determine this value experimentally. Other more utilitarian experiments would have been preferable, such as less specialised organic work than that included (examination of simple eutectics, for example) or a more extensive selection of crystal tests for inorganic ions.

Altogether the reviewer is convinced that well within the limits of space here allowed a more utilitarian presentation of the subject could have been provided. Without a good deal of further work, both in reading and in practice, the most conscientious user of this book will fall very far short of competence in the sort of problems he is likely to meet in his everyday work.—CECIL L. WILSON.

### Exemptions from KID

THE Treasury have made an Order under Section 10(5) of the Finance Act, 1926, exempting from Key Industry Duty, for the period 3 December, to 18 February, 1954, the following:—2-aminoethyl alcohol, *p*-*tert*-butylphenol, ethyl cyanoacetate and maleic anhydride. The Order is the Safeguarding of Industries (Exemption) (No. 9) Order, 1953, and is published as Statutory Instruments 1953, No. 1725. Copies may be obtained from HM Stationery Office, Kingsway, London, W.C.2, and branches, or through any bookseller.

---

# HOME

---

## Chemical Society Library

The Chemical Society Library will close at 1 p.m. on Wednesday, 23 December, for the Christmas holidays and will re-open on Tuesday, 29 December.

## Shell Reduce Nonanol Prices

A reduction of £25 per ton in the price of their Nonanol is announced by Shell Chemicals Ltd. As from 1 December a price scale will operate ranging from £195 per ton for small lots in 5-gallon drums to £150 per ton for 500 tons in 40/45 gallon drums. Other terms and conditions of sale remain unchanged.

## Air Pollution

Mr. Arnold Marsh, general secretary of the National Smoke Abatement Society, spoke on 'Air Pollution & the Law' at a joint meeting of the North Western division of the society and the North Western section of the Institute of Fuel at Liverpool last week. Modern science and technology, he said, could solve the smoke problem, but only with the backing of sound and adequate legislation.

## Nature Photography

As part of its centenary year celebrations, the Royal Photographic Society is holding an exhibition of nature photography at its headquarters, 16 Princes Gate, London, S.W.7, until 22 December. Following a private view of the exhibition last week, Field Marshal Viscount Alanbrooke introduced a showing of some of his own remarkable nature films and gave a running commentary.

## Starch & Dextrine Order Revoked

From 6 December licences will no longer be necessary for the use, obtaining and supply of starch and dextrine. The Minister of Food announced in July that, as from 27 September the distribution, sale and use of starch and dextrine would be free of existing controls. To ensure a smooth transition from control to freedom, however, it was decided to retain the licensing arrangements until a later date. There are now adequate supplies to meet the current and prospective needs of users, and the Minister has therefore revoked the Starch and Dextrine (Control) Order, 1943.

## Industrial Instruments

Evershed & Vignoles Ltd. have now taken over the responsibility for distributing the products manufactured and previously marketed by Tinsley (Industrial Instruments) Ltd. In future all correspondence in connection with Tinsley instruments should be addressed to Evershed & Vignoles Ltd., Acton Lane Works, Chiswick, London, W.4 (tel.: ELGar 6081).

## Clayton Aniline Co. Ltd.

As from 1 January next, the sales and service departments of the Clayton Aniline Co. Ltd., Clayton, Manchester 11, for both Clayton and Basle products, will operate as a separate company from the same address, but under the name of the Clayton Dye-stuffs Co. Ltd., who have also been appointed sole concessionaires for Ciba Ltd., Basle.

## Essay Competition

'Science in Industry' is the subject of an essay competition organised by *Research*, 436 Strand, London, W.C.2, from whom full particulars may be obtained. Since the competition was first announced, with prizes of £100 and £50, and an additional award of £50 for young scientists, the *Sunday Times* has agreed to offer two extra prizes of £100 and £50.

## Symposium on Gas Absorption

The Midlands branch of the Institution of Chemical Engineers is organising a symposium on 'Gas Absorption,' to be held at Birmingham University from 5-7 April, 1954. Inquiries should be addressed to 'Symposium,' Chemical Engineering Department, The University, Edgbaston, Birmingham, 15.

## Analytical Chemistry

Mr. A. A. Smales, of the Atomic Energy Research Establishment, Harwell, is to introduce a discussion on 'Radio-chemical Methods in Analysis' at a meeting of the Midlands Society for Analytical Chemistry, to be held in the Mason Theatre, Edmund Street, Birmingham, on 15 December, at 7 p.m. Mr. Smales will deal with the principles and applications of isotope dilution in analytical chemistry, also the identification and use of radioactive tracers and radio-activation.

---

# OVERSEAS

---

## New Co-enzyme Reported

The Pabst Brewing Company, whose research in fields related to food chemistry has carried it into a wide scientific realm, has announced the isolation of a new co-enzyme from yeast, uridine triphosphate. A major use of UTP, it is reported, will be in cancer research.

## New Norwegian Laboratory

To deal with problems relating to the exploitation of low-grade ores, a new laboratory, financed chiefly by contributions from the mining industry, has been built at the Norwegian Technical University, Trondheim. It is a five-storey building and near it are an ore-crushing plant and silos. Further experiments are to be made at the laboratory with iron ore from the Dunderland deposits bought by the Government, a practical method of refining the ore having already been discovered at the university.

## Oil Struck in Australia

Considerable publicity was given last week-end to the news that oil had been struck near Exmouth Gulf, about 700 miles north of Perth, by the West Australian Petroleum Co. The Secretary of the Department of National Development, Dr. H. G. Raggatt, said it was almost a foregone conclusion that a large-scale field had been found. Later it was stated that the Standard Oil Company of California was drawing up plans to develop the whole area. Oil so far found was reported to be a high-quality paraffin base oil which could yield high-grade petrol as well as kerosene diesel fuel.

## Canadian Chemical Trade

With no slackening in demand, domestic prices for chemicals in Canada remain firm, although competition in some lines is exceedingly keen, reports the Purchasing Agents' Association of Toronto. In foreign markets, mercury continues weak with Mexican competition having considerable influence. Essential oils are strong and price gains are reported. Similar strength has also been reported in industrial and edible oils. A general rise in US DDT prices has been freely predicted. New plant facilities for the production of benzol in Western Ontario are a valuable addition to domestic sources of supply.

## Uranium Extraction

For the second time since the installation of a uranium extraction plant at the Randfontein Estates mine was begun towards the end of last year, an extension to the plant has been authorised by the Atomic Energy Board of South Africa.

## Phosphorus in Coal & Coke

A new method for estimating phosphorus present in coal and coke, has been developed by the Indian National Fuel Research Institute, Jealgora. The method has been tested in four of the institute's laboratories, and is being submitted to the Standards Organisation for international use in fuel analysis.

## Another Uranium Plant

The fourth and largest uranium plant in South Africa was officially opened this week at the Western Reefs mine in the Klerksdorp district of the Far Western Rand by the Minister of Mines, Dr. A. van Rhijn. A sulphuric acid plant is included in the new plant.

## Contract for Distillation Unit

A New York message states that the Pennzoil Company has awarded a contract for a new crude oil distillation unit to the M. W. Kellogg Co., subsidiary of Pullman Incorporated. The unit will be a combination atmospheric and vacuum distillation plant capable of processing 12,000 barrels of Pennsylvania crude oil a day. It will be installed in Pennzoil's Rouseville (Pa.) refinery and will replace three smaller distillation units used for many years.

## German Plastics in 1952

During 1952, German production of artificial plastic materials amounted to 200,000 tons, which is about 12 per cent of world production. Exports totalled 23,817 tons, with a value of DM. 102,000,000. This year's production is expected to be 250,000 tons, provided exports develop favourably. During January-July, 1953, approximately 21,200 tons were exported with a value of DM. 90,000,000, as compared with 13,518 tons and DM. 70,000,000 respectively, the previous year. Exports included 47 per cent of polymerisation products, 24 per cent of condensation products and 26 per cent of products derived from cellulose.

# PERSONAL

MR. T. L. FORDY has been appointed a director of Van den Berghs & Jurgens Ltd., the margarine manufacturing subsidiary of Unilever Ltd.

MR. L. H. COOPER, chairman of the Mond Nickel Co., Ltd., has been elected a vice-president of the parent company, International Nickel Company of Canada.

MR. TILTON H. DOBBIN has been promoted from director of commercial properties to assistant treasurer of Mathieson Chemical Corporation, Baltimore, Md., and treasurer of the corporation's chemical divisions.

MR. B. WHITE has joined the board of A. Boake Roberts & Co. (Holding) Ltd.

COMMANDER K. H. S. COHEN, who, after a distinguished naval career was seconded to the intelligence department of the Foreign Office, where for many years he was responsible for continental information, has been appointed European adviser to the United Steel Companies Ltd. For some time the company has wished to make a closer study of trends in European industry and Commander Cohen will do this on their behalf.

PROFESSOR C. K. INGOLD, Professor of Chemistry, University College, University of London and Director of Chemistry Laboratories, who is president of the Chemical Society, was made an honorary life member of the New York Academy of Sciences at the annual meeting last week.

MR. R. W. OXTOBY, who has been appointed general manager of the pharmaceutical factory which is being planned for the Burmese Government by Evans Medical Supplies Ltd., is already in Rangoon for preliminary discussions with the Burmese Embassy. Hitherto, he was the company's manager for South East Asia as well as manager of their Singapore house.

MR. W. A. SHAW has been appointed sales director and elected as a member of the board of Evershed & Vignoles Ltd. He has been with the company since 1913. Succeeding him as general sales manager is MR. H. W. GRIFFITHS, formerly export sales manager.

The wedding took place at St. Margaret's Church, Thornbury, Bradford, on 5 December of MR. JOHN MITCHELL, B.Sc., son of Mrs. and the late Mr. S. Mitchell, of Moore Avenue, Great Horton, Bradford, and Miss Jean Marriott, daughter of Mrs. and the late Mr. T. A. Marriott, of Thornbury Avenue, Bradford. The bridegroom is a research chemist with the I.C.I. at Stockton-on-Tees, while the bride is a Bradford police-woman.

MR. F. J. HUNT, a director of Van den Berghs & Jurgens Ltd., has retired after 37 years in the margarine industry.

Sharples Centrifuges Limited of Stroud announce that MR. M. E. O'KEEFE TROWBRIDGE, B.Sc., A.C.G.I., A.M.I. Chem. E.,



*Mr. Trowbridge*

has recently joined their head office staff. Mr. Trowbridge was formerly Head of the Projects Initiation Department of Head Wrightson Processes Limited of London. Prior to that he was with Imperial Chemical Industries (Billingham Division). He is well known both here and in the USA

for his work on heat transfer and on solid/liquid separation processes, and is the author of a number of technical papers.

Sharples Centrifuges Ltd., by this and other staff appointments recently announced, have extended their specialist advisory service on all industrial separation and filtration problems. They are also making available in the United Kingdom a wide range of bulk solids centrifugal separators previously only manufactured by their parent company, The Sharples Corporation of Philadelphia.

Appointment of R. L. HOCKLEY as vice-president of Mathieson Chemical Corporation, following his resignation on 25 November as president of Davison Chemical Corporation, has been announced by THOMAS S. NICHOLS, Mathieson president.

Mr. Hockley will assume executive responsibilities of major importance in the Mathieson organisation. His appointment becomes effective 1 January and he will be located at the Mathieson executive offices in Baltimore.

Well known in the chemical industry, Mr. Hockley is 45 years old and has occupied various positions in Davison over the past 19 years. He is a director of the Mercantile Safe Deposit and Trust Company of Baltimore, US Hoffman Machinery Corporation, and the Manufacturing Chemists' Association, Inc.

Appointment of A. H. ANDERSEN as technical director of The Shawinigan Chemicals Limited, was recently announced in Canada by V. G. Bartrams, president of the company. Mr. Andersen, a native of Norway, joined Shawinigan Chemicals in 1926 and has been for the past two years director of development. He will be succeeded in his former post by F. K. ROGERS, assistant director of development for the past two years, who has been with the company since 1942.

When the new chemistry building of Sheffield University is opened on 5 February next by the Earl of Scarborough, Lord Chamberlain and Lord Lieutenant of the West Riding, a special degree congregation will be held. The following honorary degrees will be conferred:—LL.D.: MR. T. A. MCKENNA, chairman and managing director of the Staveley Coal & Iron Co., Ltd.; D.Sc.: SIR CYRIL HINSHELWOOD, Professor of Physical Chemistry in the University of Oxford, and past president of the Chemical Society, and PROFESSOR C. K. INGOLD, Professor of Chemistry, University College, University of London, and president of the Chemical Society.

The Professional Progress Award in chemical engineering will be presented at the annual meeting of the American Institute of Chemical Engineers next week to MR. G. E. HOLBROOK, assistant director, development department, E. I. du Pont de Nemours & Co., for 'his remarkable record as a chemical engineer in his successive positions of directing research, development, and plant production of organic chemicals and for his energetic public services in advancing the profession of chemical engineering.' Other awards to be presented at the meeting are the William H.

Walker Award for distinguished publication record, to PROFESSOR W. R. MARSHALL, JR., professor of chemical engineering, University of Wisconsin; and the Junior Member Award to PROFESSOR LEROY A. BROMLEY, associate professor of chemical engineering, University of California, Berkeley.

---

## Obituary

MR. WILLIAM BLACK, for more than 50 years managing director of the Charlestown Lime Co., Ltd., has died at the age of 87. He was associated with the lime industry in the Firth of Forth towns of Limekilns and Charlestown.

MR. IAN LE MAY MCCALLUM, director of Isdale & McCallum Ltd., Paisley soap manufacturers, and son of Mr. Charles J. McCallum, managing director of the firm, has died at the age of 40.

PROFESSOR NORMAN M. COMBER, Professor of Agricultural Chemistry and Head of the Department of Agriculture at Leeds University until he became emeritus last September, died at his home at Leeds on Saturday at the age of 65. He was born at Brighton in 1888 and was educated at a secondary school there and at the Royal College of Science in London. After taking his degree he joined the staff of the East Anglian Institute of Agriculture and from there went straight to Leeds University in 1913. He was appointed Professor of Agricultural Chemistry there in 1924 and head of the Agricultural Department in 1932. His long experience and painstaking work earned for him a national reputation in the spheres of agricultural chemistry and education. He was president of the agricultural section at the meeting of the British Association in 1949.

MR. FRANK W. SHEPHERD, a special director and superintendent of production with Dorman Long and Co., Middlesbrough, who died suddenly on Saturday at his home at Nunthorpe, near Middlesbrough, at the age of 57, had been with the firm more than 40 years. He was a member of the central council of the Iron and Steel Trades Employers' Association, of which he was a past president, a past chairman of the Cleveland Ironmasters' Association, and a past president of the Cleveland Institution of Engineers.



# Publications & Announcements

A PAPER read at an evening meeting of the Scottish department of the Pharmaceutical Society in Edinburgh last January, on 'Pharmacy and Medicine in Old Edinburgh', by C. G. Drummond, M.P.S., has been reprinted by the Pharmaceutical Press in booklet form. The paper is illustrated with a number of reproductions of early 18th-century prescriptions. Copies may be obtained, price 2s. 6d. post free, from 17, Bloomsbury Square, W.C.1.

\* \* \*

JUST as there are many different metals and their alloys, so there are many different plastics, each with special properties, and the selection of the right plastic for a job is very important. A booklet has just been published which describes the general properties of mouldings made from the more widely used Bakelite phenolic materials, and contains technical guidance for prospective users and designers. Among other materials described are mouldings which are heat, shock, water, acid and alkali, or crack resistant, and impregnated fabrics and papers. Copies may be obtained from Bakelite Ltd., at 12-18 Grosvenor Gardens, London, S.W.1.

\* \* \*

REDUCING foundry losses to a minimum is the aim of L. H. Dowling & Sons, of Minworth, Warwickshire, and a brochure recently produced by them illustrates in some detail the service they are able to offer. Their process for the reclamation of non-ferrous metal residues was developed during the war, and they are now able to collect residues from foundries and return the recovered metal within 48 hours, charges being based upon the weight of the residue processed, and not upon the weight of metal extracted.

\* \* \*

LEAFLET No. 313 from the Cambridge Instrument Co., Ltd., 13 Grosvenor Place, S.W.1, describes a new attachment for use with the Cambridge direct writing polarograph which increases its sensitivity up to a maximum of 20 times, and gives records that are simpler in form and easier to interpret. As is well known, the Heyrovsky dropping mercury electrode method of

solution analysis, on which the Cambridge polarograph is based, employs a DC supply and the records obtained generally exhibit a series of 'steps,' the position of which on the voltage scale indicates the nature of the ions present in the solution, while from the height of the 'step' it is possible to determine the concentration of the ions. The new 'Univector' attachment enables a pure AC voltage to be superimposed on the applied DC voltage and the polarograms are automatically analysed and phase-selected so that the record does not form steps but rises from the base line to a peak, the height of which is a direct linear function of the concentration of the element. The increased sensitivity obtained enables concentrations of 1 mg. per litre to be determined to 5 per cent while many substances can be detected to 0.1 mg. per litre.

\* \* \*

INCLUDED in the October issue of 'Aluminium News' is an eight-page supplement on magnesium, in the belief that users of aluminium have a natural interest in the progress of its sister light metal. Among a number of features in 'Aluminium News' is a short article on aluminium in the rubber industry. The monthly is published from Box 6090, Montreal, Canada.

\* \* \*

HITHERTO, a compound of rubber dissolved in bitumen has been used for the expansion jointing of concrete on airfields, these joints opening and closing seasonally by as much as a quarter of an inch. With jet planes, however, it has been found that not only is the bitumen softened by the fuel spilled from the jet, but the compound is softened by the heat from the engines, while the blast from them blows it from the joint on to the runway. To meet this situation, a new composition has been developed with a special primer from blends of synthetic resin and rubber, with other plastics. This, it is claimed, remains elastic whatever the weather, gives positive adhesion to the concrete and is not affected by jet fuel. Known as Semguard Grade J, the new product is made by Semtex Ltd., under the protection of patent No. 581,368 and application Nos. 6919/53 and 7122/53.

# Law & Company News

## Commercial Intelligence

The following are taken from the printed reports, but we cannot be responsible for errors that may occur.

### Mortgages & Charges

(Note.—The Companies Consolidation Act of 1908 provides that every Mortgage or Charge, as described herein, shall be registered within 21 days after its creation, otherwise it shall be void against the liquidator and any creditor. The Act also provides that every company shall, in making its Annual Summary, specify the total amount of debt due from the company in respect of all Mortgages or Charges. The following Mortgages or Charges have been so registered. In each case the total debt, as specified in the last available Annual Summary, is also given—marked with an \*—followed by the date of the Summary but such total may have been reduced.)

**RADIOL CHEMICALS, LTD.** (formerly Radi Chemicals, Ltd.), London, S.W. 4 November, mortgage, to Halifax Building Society securing £650 and further advances; charged on 135 Disraeli Road, Putney. \*Nil. 20 July, 1953.

### Satisfactions

**BRITISH EMULSIFIERS, LTD.**, London, W. Satisfaction, 12 November of mortgages registered 21 November, 1947, and 1 January, 1952.

**GURNEY SLADE LIME & STONE CO., LTD.**, Bournemouth. Satisfaction, 11 November, of charge registered 4 March, 1953.

**LEDA CHEMICALS, LTD.**, London, W. Satisfaction, 13 November, of mortgages registered 25 October and 4 December, 1951.

**PHYLAX SERUM LABORATORIES, LTD.**, Exning. Satisfaction, 7 November, of charge registered 1 May, 1950.

## New Registrations

### Q.V.F. Ltd.

Private company. (525,325.) Capital £100,000. Manufacturers of and dealers in chemical plant and laboratory apparatus and articles of all kinds made from glass, silica, quartz and other similar substances, etc. Directors: Sir Graham Cunningham, Joseph A. Falconer, Chas. J. P. Hope, Brian H. Turpin, John N. Bruce, and John G. Window. Reg. office: Mill Street, Stone, Staffs.

### Pfizer Ltd.

Private company. (526,209.) Capital £50,000. Objects: To acquire, manufacture, assemble, process, own, hold, distribute, import, export, and otherwise deal in

chemical, medical and pharmaceutical products of all kinds, etc. First directors to be appointed by the subscribers. Reg. office: 137/139 Sandgate Road, Folkestone, Kent.

## Company News

### Allen & Hanburys Ltd.

For the year ended 30 June last, group profit of £390,121 is reported by Allen & Hanburys Ltd. This compares with £471,279 for the previous year. After deducting depreciation, debenture interest and tax, etc., the net profit is shown as £72,116, against £135,964. Dividend for the year is 17½ per cent on the larger capital.

### A. Boake Roberts & Co. (Holding) Ltd.

The payment of interim ordinary dividends is being resumed by A. Boake Roberts & Co. (Holding) Ltd., the interim dividend in respect of the year ending 31 March next being 2½ per cent, less tax. This, states the board, should not be construed as indicating an increase in the total for the year. The dividend for 1952-53 was 10 per cent, less tax, compared with an interim of 5 per cent and a final of 12½ per cent, both less tax, for 1951-52. Referring to trading for the six months ended 30 September last, the chairman, Mr. F. C. Pentecost, states that during this period the new operating company found competition very keen and profit margins narrowed.

### British Benzol & Coal Distillation Co. Ltd.

A silver jubilee bonus of 5 per cent is recommended by the directors of British Benzol & Coal Distillation Co., Ltd., as well as a final dividend of 10 per cent, making 15 per cent for the year ended 31 October (the same as for the previous year). The net profit of £56,222 compares with £58,391, after tax of £70,100, against £70,000.

### Erinoid Ltd.

The trading profit of Erinoid Ltd. for the year ended 31 July was £154,012, as compared with £91,445 for the previous year. After deductions in respect of depreciation, interest on FCI loan, tax, etc., net profit is returned as £36,089, against a loss of £19,189. No ordinary dividend was paid last year, but this year one of 5 per cent is recommended.

# Do you want 5-50 Gallons of Distilled Water per DAY ?



**PERMUTIT**  
*Portable*  
**DEMINROLIT'**  
*will give it to you*

Here is the modern equivalent of distilled water, produced by 'Deminrolit' at a fraction of the cost of distillation. No heat or steam required. Operated by ion exchange, producing water free from dissolved solids.

Send for Technical Publication No. 62 giving full details.

The **PERMUTIT Company Ltd.**

Dept. V. A. 154, Permutit House, Gunnersbury Avenue, London, W.4. Telephone: CH15wick 6431

## Next Week's Events

### MONDAY 14 DECEMBER

#### Society of Chemical Industry

Leeds: The University, 7 p.m. Yorkshire section, jointly with Plastics Group and Plastics Institute. Dr. R. J. W. Reynolds: 'The Relation Between the Chemical Constitution and the Properties of Polymers.'

Newcastle: Old Assembly Rooms. Newcastle Section, jointly with RIC (Newcastle Section) and CS. Dinner and entertainment.

#### Institution of the Rubber Industry

Manchester: Engineers' Club, Albert Square, 6.15 p.m. J. Maitland-Edwards and Dr. F. H. Cotton: 'Education in the Rubber & Plastics Industries.'

### TUESDAY 15 DECEMBER

#### Society of Chemical Industry

London: Geological Society's rooms, Burlington House, Piccadilly, 5.30 p.m. Chemical Engineering Group. G. E. Eltenton: 'Instruments for Quality Control.'

#### Midlands Society for Analytical Chemistry

Birmingham: The University, 7 p.m. A. A. Smales: 'Radio-chemical Methods in Analysis.'

### WEDNESDAY 16 DECEMBER

#### Society of Chemical Industry

Dublin: Trinity College, 7.45 p.m. Dublin and District Section. Scientific films.

Falkirk: Lea Park Rooms, 7.30 p.m. Stirlingshire & District Section, jointly with Society of Public Analysts (Scottish Section). R. L. M. Syngé: 'Principles of Chromatography.'

#### Institution of Chemical Engineers

Birmingham: Mason Theatre, Edmund Street, 6.30 p.m. Graduates' & Students' Section (Midlands Centre). J. Gill: 'Fluorine Plastics.'

### THURSDAY 17 DECEMBER

#### Chemical Society

London: Burlington House, Piccadilly, 7.30 p.m. Reading of original papers.

Aberdeen: The University, 5.15 p.m. Jointly with RIC and SCI. H. W. Cremer: 'Some Aspects of Chemical Engineering.'

#### Institution of Chemical Engineers

Leeds: The University, 7 p.m. Graduates' & Students' Section (Yorkshire Centre). J. H. F. Hallet: 'The Principles & Applications of Fluidisation.'

#### Textile Institute

Manchester: 10 Blackfriars Street, 7 p.m. Dr. A. R. Urquhart: 'Artificial Fibres from Natural Polymers.'

### FRIDAY 18 DECEMBER

#### Society of Chemical Industry

London: King's College, Strand, 7 p.m. Fine Chemicals Group. D. H. R. Barton: 'Steroidal Alkaloids.'

#### Incorporated Plant Engineers

Birmingham: Imperial Hotel, 7.30 p.m. E. E. Jelliffe: 'Industrial Safety.'

## Market Reports

LONDON.—Active trading conditions continue to prevail in most sections of the industrial chemicals market and deliveries to the home consuming industries cover good quantities. More interest in contract replacement business has been in evidence but it is not yet known whether any of the existing rates are likely to be changed. Prices generally are steady, the chief alteration being a reduction of £7 15s. per ton in the price of white lead ground in oil, and £6 15s. per ton reduction in the price of red lead ground in oil. Dry white lead, dry red lead and litharge have been reduced by £2 per ton. The changes became effective as from 1 December. Most of the routine soda products are moving steadily, as also are the potash chemicals, hydrogen peroxide, acetic acid, acetone and formaldehyde. A brisk trade is passing in the coal tar products market with the light distillates remaining in short supply.

MANCHESTER.—From the point of view of new business there have been signs on the Manchester chemical market during the past week of the usual year-end slackening of buying interest and this is likely to continue over the next few weeks. Contract deliveries of textile and other industrial chemicals, however, have again been on reasonably steady lines and prices are held pretty well throughout the range. Among fertilisers basic slag is being taken up in good quantities, with a moderate trade passing in most other sections. In the tar products market, creosote oil, carbolic acid, and most of the light distillates are going steadily into consumption.

GLASGOW.—There has been considerable activity in the heavy chemical market during this week consequent on the tendency to increase prices for continental materials and home products.

# INTERMEDIATE PRODUCTS ANILINE DYES FAST BASES FOR ICE COLOURS

Benzol, Nitrobenzol, Binitrobenzol, Toluol, Ortho & Para Nitrotoluol, Binitrotoluol (All Grades)

Para Nitro Ortho Toluidine, Meta Nitro Para Toluidine

ORTHO TOLUIDINE      PARA TOLUIDINE

Extensive Range of Oil Colours, Acid Colours, Basic Colours, Direct Colours, Pigment Colours,

Azoic Colours for Wool, also Colours suitable for all Trades

META TOLUYLENE DIAMINE      META PHENYLENE DIAMINE

## JOHN W. LEITCH & CO., LTD.

MILNSBRIDGE CHEMICAL WORKS

Telephone :  
189-190 MILNSBRIDGE

### HUDDERSFIELD

Telegrams :  
LEITCH, MILNSBRIDGE

**INDIA**  
Khatau Valabhdas & Co.  
Vadgadi, Bombay.

**SCOTLAND**  
Kirkpatrick & Lauder Ltd  
180, Hope Street, Glasgow C.2.

**CANADA**  
Prescott & Co., Regd.  
2209 Hingston Ave.,  
N.D.G. Montreal 28, Quebec.

*Announcing the Opening of the New*

**TOWERS LONDON AREA BRANCH**

*January 1954*

at  
Wallingford Rd.,  
Industrial Estate,  
**UXBRIDGE,**  
Middlesex

*For all Scientific  
Supplies 'phone  
**TOWERS at  
UXBRIDGE 8461***

Servicing the  
Counties of :—

**LONDON**  
BEDFORD  
BERKSHIRE  
BUCKINGHAM  
CAMBRIDGE  
ESSEX  
HERTFORD  
KENT  
MIDDLESEX  
OXFORD  
SURREY  
SUSSEX

Prompt motor delivery service.

## J. W. TOWERS & CO. LTD.

Head Office & Works : WIDNES, Lancashire

Branches : Manchester, Liverpool, Stockton-on-Tees.

# CLASSIFIED ADVERTISEMENTS

## SITUATIONS VACANT

*The engagement of persons answering these advertisements must be made through a Local Office of the Ministry of Labour or a Scheduled Employment Agency if the applicant is a man aged 18-64 inclusive, or a woman aged 18-59 inclusive, unless he or she, or the employment, is exempted from the provisions of the Notifications of Vacancies Order, 1952.*

**SENIOR SCIENTIFIC OFFICERS; SCIENTIFIC OFFICERS; PATENT EXAMINER AND PATENT OFFICER CLASSES.** The Civil Service Commissioners invite applications for permanent and pensionable appointments to be filled by frequent competitive interviews. The Scientific posts are in various Government Departments and cover a wide range of Scientific research and development in most of the major fields of Fundamental and Applied Science. In Biological subjects the number of vacancies is small; individual vacancies exist at present for candidates who have specialised in Palaeobotany, Invertebrate Fossils and Foraminifera. The Patent posts are in the Patent Office (Board of Trade), Admiralty and Ministry of Supply.

Candidates must have obtained a University Degree with first or second-class honours in an appropriate scientific subject (including Engineering) or in Mathematics, or an equivalent qualification; or for Scientific posts, possess high professional attainments. Candidates for Senior Scientific Officer posts must in addition have had at least three years' post-graduate or other approved experience.

**AGE LIMITS:** Senior Scientific Officers, between 26 and 31, but specially suitable candidates under 26 may be admitted. For Scientific Officers and Patent Classes, between 21 and 28 during 1953 (up to 31 for permanent members of the Experimental Officer Class competing as Scientific Officers). Inclusive London salary scales: Senior Scientific Officers (men), £917-£1,075; (women), £786-£949; Scientific Officers (men), £440-£812; (women), £440-£707. Patent Examiner and Patent Officer Classes (men), £440-£760; (women), £440-£576. Women's rates for Patent Classes under review. Somewhat lower rates in the provinces.

Further particulars from the **CIVIL SERVICE COMMISSION, SCIENTIFIC BRANCH, TRINIDAD HOUSE, OLD BURLINGTON STREET, LONDON, W.1** (quoting No. S.53/53 for Senior Scientific Officers and S.52/53, S.128/53 for the other posts). Completed application forms to be returned on or before 31st December, 1953. 24054/100/J.P.

**JOHNSON, MATTHEY & CO., LIMITED**, Refiners and Engineers in Precious and Special Metals, offer a **SENIOR APPOINTMENT**. Candidate must be between the ages of 30 and 40 and be technically highly qualified, preferably in extraction metallurgy and have proven ability as an organiser and works experience, both technical and administrative. He should possess strong commercial sense and cost consciousness, be able to develop processes and plant from experimental and pilot stages, design and supervise construction of commercial working units, and have ability to recognise potential commercial value of ideas and to develop and exploit them. This post offers wide scope to man of established worth. Write giving full particulars of career to date, present salary, and reasons for application to **SECRETARY, JOHNSON, MATTHEY & CO., LIMITED, 78, HATTON GARDEN, LONDON, E.C.1.**

**MILL CHEMIST** (Graduate) required for Paper Mills in Lanarkshire, Scotland. Applicants should have practical experience in paper manufacture; salary in accordance with qualifications. Write, giving full particulars age, education, qualifications and experience, salary expected, etc., to **SECRETARY, ROBERT CRAIG AND SONS, LTD., MOFFAT MILLS, AIRDRIE, LANARKSHIRE.**

## SITUATIONS VACANT

**ENGINEER or CHEMIST** required by Chemical Engineering Firm in London. Qualifications are:—Age about 30; experience in pickling and chemical treatment of metals; experience of general office procedure and technical sales an advantage. The position offers excellent opportunities to a man having these qualifications, coupled with a keen business outlook. Write, stating fullest possible particulars, including age, qualifications and salary required, to **BOX No. C.A. 3282, THE CHEMICAL AGE, 154, FLEET STREET, LONDON, E.C.4.**

**WELL-KNOWN** French Firm manufacturing complete Chemical Plants and Equipment, with world references, wants for U.K. first-class Agent, live wire, well introduced in Chemical Industry, preferably with some Chemical Engineering knowledge. Apply, with full details references, **LILLET 12850 RUE VIVIENNE 17—PARIS.**

## FOR SALE

- 8 brand new jacketed **STERILIZING VESSELS**, 7 ft. long by 3 ft. diam., complete with fittings.
- 2—18 in. **KEK PLATE MILLS**, complete with feeders delivery bins, motors and entablature.
- 9 Worssam **ROTARY PRESSES.**
- POWDER DRESSING or SIFTING MACHINES**, various sizes.
- 1 Johnson **FILTER PRESS**, 36 in. square, plate and frame type, double inlet and enclosed delivery ports.
- 1 Johnson **FILTER PRESS**, 47 plates, 32 in. square, centre feed, bottom corner open delivery.
- Wood **FILTER PRESS**, fitted 69 ribbed plates, 2 ft. 8 in. square, with top centre feed and bottom enclosed delivery channel.
- 24 in., 30 in. and 36 in. **HYDRO EXTRACTORS**, self-balancing, swan-neck type, self-emptying bottom, belt and motor driven.
- Heavy cake **CRUSHING MILL**, 2-pair high, by Nicholson, for cake up to 3 in. thick, rolls 30 in. long, top with coarse teeth 9 in. diam. bottom with finer teeth 12 in. diam.
- Bennett Copper-built **EVAPORATOR**, 4 ft. diam. by 4 ft. 6 in. high, steam jacketed bottom, mounted on legs, with swan-neck vapour pipe and separate vertical belt driven vacuum pump.
- "U" shaped horizontal jacketed **MIXER**, 7 ft. long, 3 ft. wide, 3 ft. 3 in. deep, belt and gear driven.
- 3—5 roll **REFINERS**, fitted chilled iron, water-cooled rolls, 40 in. long, 16 in. diam. belt and gear driven, with clutch drive suitable for motor, by Baker Perkins, Ltd.
- 1 No. 1A water-cooled **CIRCULATOR MILL.**
- 6—Excellent Nickel-lined Jacketed **TILTING PANS**, 60 gallons capacity and for 40 lb. working pressure.
- 2—Brand New Enclosed Aluminium **TANKS**, approximately 11 ft. long by 4 ft. 9 in. wide by 7 ft. 3 in. deep.
- 5—Excellent Porcelain **DISC MILLS.**
- 1—Aluminium **STILL**, steam jacketed, dished top and bottom; approximately 4 ft. 8 in. diameter by 6 ft. deep.
- 1—Very fine **GARDNER SIFTER and MIXER**. Internal dimensions of trough, 5 ft. 9 in. by 24 in. by 23 in. deep, complete with wood-built hopper, elevator, A.C. motor and starter, all in first-class condition.

**RICHARD SIZER, LTD.,  
ENGINEERS,  
HULL.**

Telephone 31743.

## FOR SALE

**CHARCOAL, ANIMAL AND VEGETABLE**  
horticultural, burning, filtering, disinfecting,  
medicinal, insulating; also lumps ground and granulated;  
established 1830; contractors to H.M. Government.—  
**THOS. HILL-JONES, LTD., "INVICTA" WORKS, BOW**  
**COMMON LANE, LONDON, E. TELEGRAMS: "HILL-**  
**JONES, BOCHURCH LONDON." TELEPHONE 3285**  
**EAST.**

**ECONOMIC BOILERS**—9 ft. diam. by 12 ft. 6 in.  
Foster Yates, 200 lb. w.p.; 8 ft. diam. by 14 ft.  
Paxman, 180 lb. w.p. Twenty others, all sizes.  
Whessoe Open Top Riveted Steel **MIXING TANK**  
13 ft. diam., by 15 ft. deep, 9/16 in. plate.

**NEW GALVANISED PIPING.** Immediate delivery.  
Johnson Filter **PRESSES**, 25 in., 18 Frame,  
practically new.

**TWO** 35 ft. long by 9 ft. diam. Lead-lined **TANKS.**  
**ONE** Stainless **CONICAL HOPPER**, 7 ft. 3 in. diam.,  
overall depth, 7 ft. 6 in.

**TWO** Broadbent **WATER-DRIVEN CENTRIFUGES**,  
30 in. diam., 12 in. deep, 1,150 r.p.m., 150 lb.  
pressure.

**SIX O.T. TANKS**, 7 ft. diam., 14 ft. deep, rubber and  
brick lined.

**Six Aluminium CONDENSERS**, 14 ft. long by 2 ft. 6 in.  
diam. 386 Tubes, 3/4 in. o.d.

**FORTY Riveted RECEIVERS**, 8 ft. 6 in. long, 5 ft. 6 in.  
diam., 75 lb. w.p.

**CAST-IRON PIPES**, 5000 ft. Each 6 in. and 8 in. **NEW**  
**VALVES** in Stainless, Gunmetal, Enamel Lined.  
Free Catalogue. "Watkins Machinery Record," available

**FRED WATKINS, (BOILERS) LTD.,**  
**COLEFORD, GLOS.**

**STAINLESS STEEL PLATE HEAT EXCHANGER**  
by A.P.V. CO., LTD. Type HH. 76 plates 43 in  
by 16 in., total projected area 346 sq. ft.  
Hydraulically operated opening and closing gear.

**STAINLESS STEEL CRYSTAL DRIER** by MITCHELL,  
3 ft. 6 in. diam. by 1 ft. 6 in. deep. **STEAM**  
**JACKETED** flat bottom with two S.S. paddles  
underdriven through bevel gearing from direct-  
coupled 1 h.p. 400/3/50 geared motor. Jacket  
working pressure, 15 lb. per square inch.

**M.S. SPIRIT EXTRACTION PLANT**, comprising 3 ft.  
diam. by 5 ft. deep extractor with dished bottom  
jacketed for 5 lb. per square inch working pressure,  
condenser, separator, storage tank.

**KESTNER HORIZONTAL TUBULAR EVAPORATOR**,  
having six turns copper tube 1 1/2 in. bore by 6 ft.  
long, complete with copper reception pot.

**STEAM JACKETED COPPER STILL**, 150 gallons  
capacity. Fitted swan-neck, sight and light  
glasses, etc., and complete with copper coil con-  
denser. Jacket working pressure 40 lb. per  
square inch.

**STEAM JACKETED COPPER BOILING PAN**, 100 gallons  
capacity. Bolted-on cast-iron jacket suitable for  
40 lb. per square inch working pressure.

**DOUGH MIXER**, having "U" trough 1 ft. 5 in. by  
1 ft. 7 in. wide at top by 2 ft. deep. Sheet brass  
trough, cast-iron ends, G.M. agitator. Belt driven  
and arranged for hand tilting.

**M.S. HORIZONTAL "U" TROUGH MIXER**, 3 ft. by  
1 ft. 9 in. by 2 ft. deep. Fin-type agitating gear  
belt driven through helical gearing from fast and  
loose pulleys. Arranged for hand tilting.

Cast-iron **VACUUM DRYING OVEN** by TAYLOR,  
4 ft. by 2 ft. 10 in. by 4 ft. 6 in. front to back,  
having ten steam-heated M.S. platens pitched at  
3 in. Hinged door at each end. Steam working  
pressure, 15 lb. per square inch.

**HARRISON-CARTER DISINTEGRATORS**, sizes 2 1/2 and  
00. Belt driven.

**PROCESS & CHEMICAL ENGINEERING CO., LTD.,**  
**6/8, NORTHUMBERLAND PARK,**  
**TOTTENHAM,**  
**LONDON, N.17.**

Phone: Tottenham 2436 (3 lines).

## FOR SALE

**C. BARBER, LTD.**

**C.I. FILTER PRESS**, 25 1/2 in. square, by **MANLOVE**  
**ALLIOTT**, plate and frame type, 13 chambers,  
arranged for washing. Excellent condition.

**TWO HYDRO EXTRACTORS**, 72 in., by **BROADBENT.**  
(One new and unused.)

**TWO "HORMANN" 30 cm. Stainless Steel FILTER**  
**PRESSES.**

**STORAGE BINS** in stainless steel, cylindrical, with  
covers. 40/12/14/10 gallons capacity.

**CANNON STEAM-JACKETED ENAMEL-LINED PANS**,  
10 and 25 gallons. All new and unused.

**DOULTON 25-gallon COPPERS** with lids. **NEW** and  
unused.

**WELDED VESSELS** of all types, in mild steel or stainless.  
Fabricated to customer's specifications.

**HYDRO-EXTRACTOR**, 26 in., by **CHERRYTREE.**

**C. BARBER LTD.**

**SILVERDALE GARDENS**  
**HAYES MIDDLESEX**

Telephone—Hayes 2735/6

**600****ECONOMIC BOILERS**

**SELF-CONTAINED ECONOMIC** by **H. T. DANKS**,  
8 ft. 6 in. dia. by 14 ft. long between tubeplates.  
Evap. 8,000 lb. at 100 lb. W.P. oil fired. Equip-  
ment includes main oil storage tank, feed tanks  
and feed pumps.

**SELF-CONTAINED ECONOMIC** by **WILSON BOILER**  
**WORKS**, treble pass, 8 ft. diam. by 11 ft. 6 in.  
over tubeplates. Evap. 6,500 lb. at 160 lb. W.P.  
Complete with coal and oil firing equipment by  
Clyde Fuel Systems.

**SELF-CONTAINED ULTRANOMIC** by **DAVEY PAXMAN**,  
8 ft. diam. by 9 ft. 3 in. over tubeplates. Treble  
pass. Evap. 5,196 lb. at 160 lb. W.P. Hand  
coal firing.

**SELF-CONTAINED ECONOMIC** by **DAVEY PAXMAN**,  
7 ft. 6 in. diam. by 12 ft. 6 in. over tubeplates.  
Evap. 4,500 lb. at 140 lb. W.P. Hand coal fired.

**TWO SELF-CONTAINED ECONOMIC** by **DANIEL**  
**ADAMSON**, 7 ft. 6 in. diam. by 12 ft. 6 in. long  
over tubeplates. Evap. 4,140 lb. at 160 lb. W.P.  
Hand coal fired. Both new.

**NEW SELF-CONTAINED FARRARTUBE ECONOMIC**,  
7 ft. diam. by 12 ft. 6 in. over tubeplates. Evap.  
4,100 lb. at 120 lb. W.P. Hand coal fired.

**TWO SELF-CONTAINED ECONOMIC** by **JOHN**  
**THOMPSON**, 6 ft. diam. by 9 ft. 6 in. over tube-  
plates. Evap. 2,400 lb. at 100 lb. W.P. Each  
fitted with Hodgkinson Sprinkler Stockers.

**TWO SELF-CONTAINED ECONOMIC** by **EDWIN**  
**DANKS**, 5 ft. 6 in. diam. by 9 ft. 6 in. over tube-  
plates. Evap. 1,800 lb. at 100 lb. W.P. Both  
oil fired with Cycle Rotamiser Equipment.

**GEORGE COHEN SONS & CO., LTD.,**  
**WOOD LANE, LONDON, W.12.**

Tel.: Shepherds Bush 2070 and  
**STANNINGLEY, NR. LEEDS.**

Tel.: Pudsey 2241.

**FOR SALE. JOHNSON PLATE AND FRAME FILTER**  
**PRESS, HARD RUBBER COVERED THROUGHOUT.**  
17-in. square cakes, 14 frames, side feed and side dis-  
charge, hand screw closing. Price £375. **BOX No.**  
**C.A. 3280, THE CHEMICAL AGE, 154, FLEET STREET**  
**LONDON, E.C.4.**

**MONEL METAL-LINED STEAM JACKETED PAN**,  
75 gallons capacity; also **COPPER STEAM**  
**JACKETED PAN**, 40 in. diam. by 12 1/2 in. deep.  
**HAROLD POTTER & CO., LTD., CANAL STREET,**  
**NOTTINGHAM.**

---

**FOR SALE**

---

**MORTON, SON & WARD, LIMITED**

offer  
**"MORWARD" "U"-shaped Trough POWDER MIXERS**, any size up to 3 tons.  
**MIXERS**—Horizontal or Vertical, jacketed or unjacketed. Several in stock.  
**JACKETED PANS** in stainless steel or mild steel, with or without mixing gear.  
**TROUGH MIXER** by **CHALMERS**, 3 cwt., stainless steel lined tilting trough.  
**TROUGH MIXERS** by **GARDNER**, 3 cwt., stainless steel lined troughs.  
**ONE 500g. JACKETED AUTOCLAVE** with detachable cover, 150 lb. in jacket.  
**500g., 300g. and 200g. AUTOCLAVES** in mild steel riveted construction, with detachable covers.

**HYDRO EXTRACTORS**

Large selection in stock, 72 in. to 36 in., by **BROADBENT**, and 42 in. by **WATSON LAIDLAW**, all electric, underdriven, thoroughly reconditioned, complete with starters and guaranteed.

**PUMPS**: A range of new **MONO** Pumps and several other 2 in. to 6 in. in stock. New and second-hand.

**INQUIRIES INVITED.**

**MORTON, SON & WARD, LIMITED,**  
**WALK MILL,**  
**DOBCROSS, NR. OLDHAM,**  
**LANCS.**

Phone: Saddleworth 437.

**PHONE 98 STAINES**

**850** gallon **RUBBER LINED CYLINDRICAL ENCLOSED TANKS**, 8 ft. 6 in. by 4 ft. 6 in. diam.  
**7,000** gallon **GLASS LINED CYLINDRICAL ENCLOSED TANKS**, 18 ft. by 9 ft. diam.

**GUNMETAL DUPLEX FIN-BLADE JACKETED TILTING ENCLOSED MIXER** by "MELVIN," 29 in. by 27 in. by 24 in.

**JACKETED CYLINDRICAL STEEL MIXING PANS**, 30, 40, 100, 150 up to 1,375 gallons.

**S.S. Pans**, 100 and 50 gallons; **DITTO**, jacketed, 50 gallon with electric stirrer.

Two—**PORTABLE ELECTRIC STIRRERS**, 400/3/50 (unused).

**PUMPS, HYDROS, STILLS, OVENS, DRYERS, CONDENSERS, ETC.**

**HARRY H. GARDAM & CO., LTD.,**  
**STAINES.**

**ONE TORRANCE MICRO TWIN-ROLLER MILL.** Cast rolls, 14 in. by 8 in. Water cooled. Fast and loose pulley-drive.

**TWO DE LAVAL SEPARATORS, VEE-BELT DRIVE.** Good condition.

**THOMPSON & SON (MILLWALL), LIMITED,**  
**CUBA STREET, LONDON, E.14. TEL. EAST 1844.**

---

**WANTED**

---

**INDUSTRIAL BY-PRODUCTS, LTD.**, 16, Philpot Lane, London, E.C.3, will be pleased to receive particulars of any by-products, waste materials and residues for disposal.

---

**SERVICING**

---

**CRUSHING, GRINDING, MIXING and DRYING** for the trade.  
**THE CRACK PULVERISING MILLS LTD.**  
 Plantation House,  
 Mining Lane,  
 London E.C.2.

---

**SERVICING**

---

**GRINDING, CRUSHING AND GRADING**

**FINE GRINDING LTD.,**

**BLACKHOLE MINE, EYAM**

**TELEPHONE: EYAM 227**

**PULVERISING** of every description of chemical and other materials for the trade with improved mills, wharfage, and storage facilities. **THOS. HILL-JONES LTD., "INVICTA" WORKS, BOW COMMON LANE, LONDON, E.** **TELEGRAMS: "HILL-JONES, BOCHURCH LONDON."** **TELEPHONE 3285 EAST.**

**WET AND DRY GRINDING**, Micronising, Grading and Mixing of Minerals and Chemicals for all trades. Also suppliers of ground zircon, sillimanite, fused silica, precision casting materials and a wide range of ground minerals.

**W. PODMORE & SONS, LTD.,**  
**SHELTON, STOKE-ON-TRENT,**  
 Phones **STOKE-ON-TRENT 2814 & 5475**

---

**WORKING NOTICES**

---

**THE** Proprietors of Patent No. 582908, for "PROCESS FOR THE CLARIFICATION OF GLYCEROL LIQUORS OBTAINED BY THE FERMENTATION OF NATURAL OCCURRING CARBO-HYDRATES SUCH AS MOLASSES," desire to secure commercial exploitation by licence or otherwise in the United Kingdom. Replies to **HASELTINE LAKE & CO., 28, SOUTHAMPTON BUILDINGS, CHANCERY LANE, LONDON, W.C.2.**

**THE** Proprietor of British Patent No. 644030, entitled "IMPROVEMENTS IN THE PRODUCTION OF CARBON DISULPHIDE," offers same for licence or otherwise, to ensure its practical working in Great Britain. Inquiries to **SINGER, STERN & CARLBERG, CHRYSLER BUILDING, NEW YORK 17, N.Y., U.S.A.**

---

**PATENTS & TRADE MARKS**

---

**KINGS PATENT AGENCY, LTD.** (B. T. King, B.A.M.I. Mech. E., Patent Agent), 146a, Queen Victoria Street, London, E.C.4. **ADVICE** Handbook, and Consultation free **Phone: City 6161.**

**For Classified Advertising**  
**THE CHEMICAL AGE**

Gives direct and immediate penetration. Is the recognised liaison between buyer and seller.

Accepts advertisements up to first post on Tuesday for insertion in that week's issue.

Gives a reduced rate for more than three insertions and

**PULLS IN RESULTS**



# KEEBUSH

Keebush is an acid-resisting constructional material used for the construction of tanks, pumps, pipes, valves, fans, etc. It is completely inert to most commercial acids; is unaffected by temperatures up to 130°C; possesses a relatively high mechanical strength, and is unaffected by thermal shock. It is being used in most industries where acids are also being used. Write for particulars to—

## KESTNER'S

5 Grosvenor Gardens, London, S.W.1

## Solvent Recovery Plant

### Carbon Adsorption System

British Carbo-Norit Union, Ltd.  
176, Blackfriars Rd., London, S.E.1

THE WORLD'S GREATEST BOOKSHOP

# FOYLES

★ FOR BOOKS ★

All new Books available on day of publication. Secondhand and rare Books on every subject. Stock of over three million volumes

Subscriptions taken for British, American and Continental Magazines

119-125 CHARING CROSS RD., LONDON, W.C.2  
Gerrard 5660 (16 lines) ★ Open 9-6 (inc. Sat.)  
Nearest Station: Tottenham Court Road

FOR VALVES AND COCKS FOR ACIDS  
IN IMPROVED DESIGNS

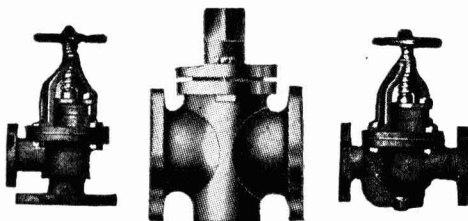

HAUGHTON'S METALLIC CO., LTD.  
30, ST. MARY-AT-HILL, LONDON, E.C.3

# BOULTON

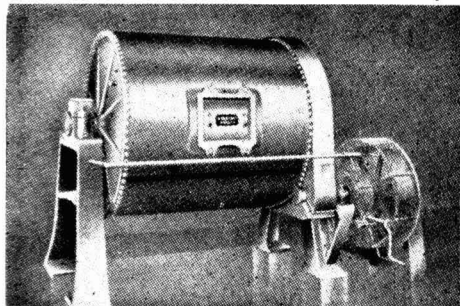

Ball & Pebble Mills  
ALSO RELINING IN PORCELAIN, STEEL, ETC.

WILLIAM BOULTON LTD.  
PROVIDENCE ENGINEERING WORKS  
BURSLEM · STOKE-ON-TRENT

PHONE: STOKE-ON-TRENT 87234 (4 Lines) TELEGRAMS: BOULTONS BURSLEM

## The Outstanding Issue of the Year



### A MILESTONE IN CHEMICAL TRADE JOURNALISM

The 1954 *Chemical Age* Annual Review Number will be a digest of an eventful year. It will record progress in instrumentation, modern laboratory equipment, new plant and machinery, the rapid strides in inorganic, organic, analytical and physical chemistry and the manner in which these advances have been applied to chemistry in industry. It will be a permanent record of chemistry in 1953.

## The Chemical Age

ANNUAL REVIEW NUMBER

JANUARY 9th 1954

Book Your Advertisement NOW and get the Best Choice of Position

## INDEX TO ADVERTISERS IN THIS ISSUE

	Page		Page
Alumina Co., Ltd. (The)	1210	Kilner, John, & Sons (1927), Ltd.	1250
Audley Engineering Co., Ltd.	1203	Leigh & Sons Metal Works, Ltd.	1250
Berk, F. W., & Co., Ltd.	Front Cover	Leitch, John W., & Co., Ltd.	1245
Blundell & Crompton, Ltd.	Cover Three	Marchon Products, Ltd.	1207
Boulton, William, Ltd.	1249	Markland Scowcroft, Ltd.	Cover Three
British Carbo-Norit Union, Ltd.	1249	Penryhn Quarries, Ltd.	1250
British Oxygen Co., Ltd. (The)	1206	Permutit Co., Ltd. (The)	1243
Classified Advertisements	1246, 1247, 1248	Petrochemicals, Ltd.	1205
Cohen, George, Sons & Co., Ltd.	1209	St. Helens Cable & Rubber Co., Ltd.	1204
Foyle, W. & G., Ltd.	1249	Steele & Cowlshaw, Ltd.	1210
Glebe Mines, Ltd.	1208	Sutcliffe Speakman & Co., Ltd.	Cover Two
Harris (Lostock Gramam), Ltd.	Cover Three	Technical Paper Sales, Ltd.	1206
Haughton's Metallic Co., Ltd.	1249	Towers, J. W., & Co., Ltd.	1245
Hess Products, Ltd.	1211	Unifloc, Ltd.	1214
Holmes, W. C., & Co., Ltd.	1208	Urquhart's (1926), Ltd.	1210
Jobling, James A., & Co., Ltd.	1212	Wilkinson, James, & Son, Ltd.	1214
Kestner Evaporator & Engineering Co., Ltd.	1249	Wilkinson Rubber Linatex, Ltd.	Back Cover
		Wood, Harold, & Sons, Ltd.	1250

**"Fullersite"** SLATE FILLER  
*for*  
 BITUMINOUS PRODUCTS, PAINTS,  
 MOULDED RUBBER GOODS,  
 PHARMACY, CERAMIC WARE  
 apply:—**PENRHYN QUARRIES LTD.**  
 Port Penrhyn, Bangor  
 N. Wales

SPECIALISTS IN  
**BULK LIQUIDS**  
 TRANSPORT  
 Acids • Oils • Spirits  
 and General Chemicals

**Harold Wood & Sons, Ltd.**  
 Wormald Street, Heckmondwike  
 Telephone: HECKMONDWIKE 1011/5  
 Telegraphic Address: "Transport" Heckmondwike  
 London Office: 22 SOUTH MOLTON ST., LONDON, W.1  
 Telephone: Mayfair 6060

**"ZULO"**



**LEIGH & SONS METAL WORKS LTD.**  
 Orlando St., BOLTON

**CARBOY HAMPERS**

CARBOYS; PACKED CARBOYS  
 CARBOY TILTERS AND BARROWS.  
 SAFETY CRATES TOP PROTECTORS.

**JOHN KILNER & SONS (1927) LTD**  
 ESTABLISHED 1867  
 Calder Vale Glass Works, Wakefield, Yorks.  
 'PHONE: WAKEFIELD 2042 'GRAMS: GLASS, WAKEFIELD

SPECIALISTS IN

**Carboys • Demijohns  
 Winchesters**

# "VULCAN"

BRAND

**CARBOY HAMPERS**

**PACKED CARBOYS**

**SAFETY CRATES**

**PROTECTING HOODS.**



**HARRIS**  
**(LOSTOCK GRALAM) LTD.**  
**LOSTOCK GRALAM,**  
**NORTHWICH**

## COPPER PLANT

for the CHEMICAL TRADES

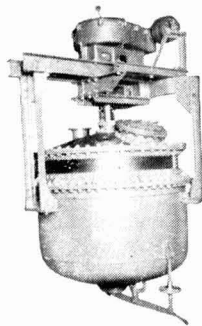

*Large steam jacketed copper Boiling and Mixing Pan with geared agitators, steam jacket of mild steel*

**STILLS**  
**RECTIFYING**  
**COLUMNS**  
**CONDENSERS**

—  
**Autoclaves**  
**Calandrias**  
**Vacuum Pans**  
**Boiling Pans**  
**Pipework,**  
**Coils, etc.**

ESTABLISHED 1825

**BLUNDELL & CROMPTON**  
LIMITED

WEST INDIA DOCK RD., LONDON, E.14  
Phone: East 3838 (3 lines) Grams: Blundell,  
& 1408 Phone, London

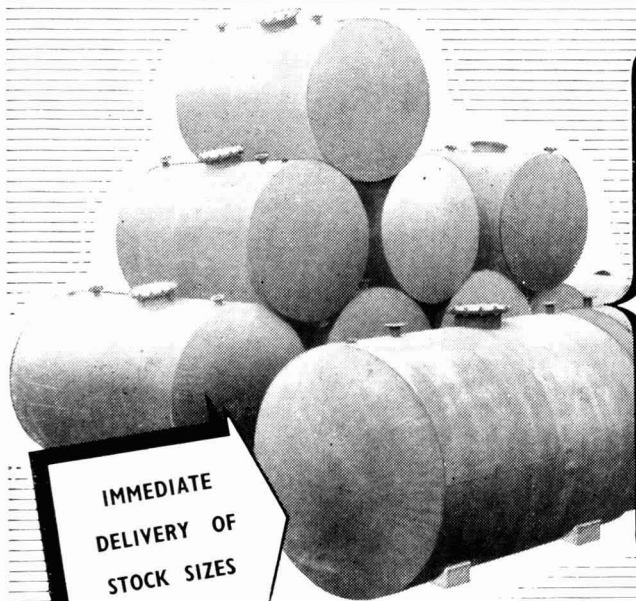

**IMMEDIATE**  
**DELIVERY OF**  
**STOCK SIZES**

### HIGH GRADE STORAGE VESSELS

available for your immediate use—  
in sizes ranging from 500-5,000  
gallons, while special sizes can  
be delivered to order

Our vessels are steel plated, electrically welded and can be specially treated for all classes of work—for use underground and for storing solvents and practically every fluid. Every vessel is tested before delivery

Write, phone or call for price list and details of any size tank in which you are interested.

Markland Scowcroft, with their wide experience and skilled craftsmanship, are also at your service for Boilers Tubes Valves and Fittings.

M.T.O.T.

**MARKLAND SCOWCROFT LTD**

**COX GREEN WORKS, BROMLEY CROSS**  
**NEAR BOLTON. Phone EAGLEY 600**



These tanks, at one of the largest chemical plants in the north have been lined internally with 9,000 sq. ft. of Linatex. This *repeat* order is further striking testimony to the toughness and durability of this 95% pure natural rubber. Linatex resists corrosion and abrasion—is resilient and non-absorbent. For over 25 years Linatex has been specified for structures, plant, machinery and equipment of every description. Its uses are unlimited. Our resident engineer in your district will be pleased to tell you all about Linatex — and how it might solve your problem.

**LINATEX** for linings—95% pure natural rubber



making rubber serve industry

Wilkinson Rubber Linatex Ltd., Frimley Rd., Camberley, Surrey. Tel: CAMberley 1595 *Factories and Distributors throughout the World*

L24