

# THE Chemical Age

VOL. LXX

17 APRIL 1954

No. 1814

**CRUICKSHANK'S**

**acids  
and**



**chemicals**

Hydrofluoric Acid

and Fluorides

Fluoboric Acid and

Fluoborates

Hydrofluosilicic Acid

and Silicofluorides

Cyanides of Cadmium, Copper,  
Gold, Nickel, Potassium,  
Sodium, Silver, Zinc

**Nickel and Zinc Compounds**

**Liver of Sulphur**

**Prepared Plating Salts** for  
Brass, Cadmium, Chromium,  
Copper, Nickel, Silver, Tin,  
Zinc, etc.

**Copper Salts**

Carbonate, Chloride,  
Nitrate, etc.



Phone :  
Central 8553 (6 lines)  
Grams :  
Cruickshank, B'ham

**R. CRUICKSHANK LTD**

**CAMDEN STREET  
BIRMINGHAM, 1**

# Simplicity

## Steam Traps

cannot jam or blow steam. Unique in design, foolproof in operation.

"Simplicity" Steam Traps have only one moving part—a free floating stainless steel sphere.

Each trap is guaranteed. Send for a trap on trial. Write for fully descriptive pamphlet, No. ST9A.

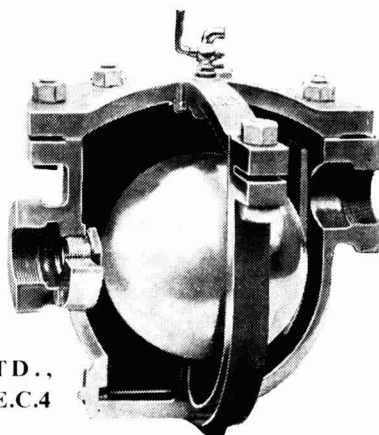

THE KEY ENGINEERING CO., LTD.,

4, Queen Victoria Street, London, E.C.4

Telephone ; City 1185/6



and Trafford Park, Manchester.

Tel : Trafford Park 1903

DHF 7

### HYDRATED CARBONATE OF POTASH

83/85%  
In Polyethylene Lined Barrels

### CALCINED CARBONATE OF POTASH

96,98% and 98/100%

### CAUSTIC POTASH

Solid Fused  
90/92%

### POTASSIUM PERMANGANATE

Pharmaceutical and Technical

### TITANIUM DIOXIDE

Anatase Quality 98/100% TiO<sub>2</sub>

Enquiries to :

## CHEMITRADE LIMITED

17 STRATTON ST. • LONDON W.1

Telephone : GROsvenor 3422

Cables : Multikem, London

Carbonate of Potash supplied in conjunction with Mercantile Holding & Trading Co., Ltd.

# 2 new

## MONOCARBOXYLIC ACIDS

### SICCATIC ACID 'A'

(Dineopentyl Acetic Acid)

M.pt. 81-83°C  
Mol.Wt. 200

### SICCATIC ACID 'B'

(Methyl-tert Butyl Neopentyl Acetic Acid)

M.pt. 125-127°C  
Mol.Wt. 200

Research Samples and Technical information available on application.

## ALCHEMY LIMITED

HEAD OFFICE :  
Brettenham House, Lancaster Place, Strand,  
London, W.C.2. Tel. No. : TEMple Bar 5801

# PERFORATED METALS

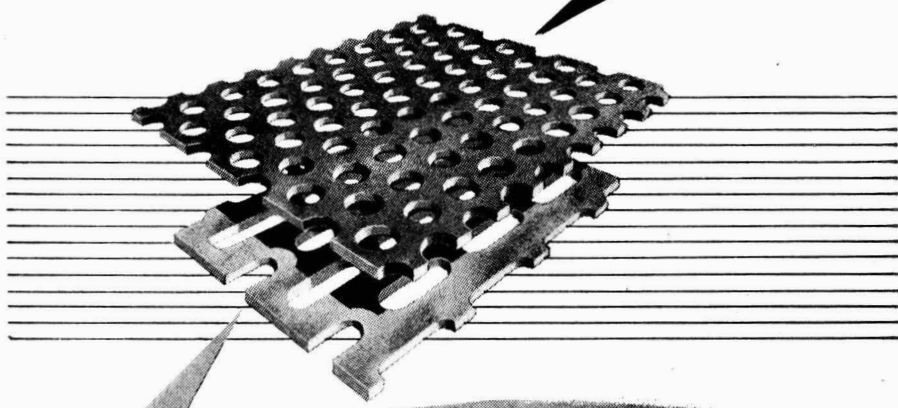

- \* ANY SIZE OR SHAPE OF HOLE . . . . .
- \* IN ALL METALS . . . . .
- \* ACCURATE AND DURABLE

 **Greenings**  
N. GREENING AND SONS LTD  
BRITANNIA WORKS  
WARRINGTON • ENGLAND  
P.O. BOX 22

ESTABLISHED 1799  
Telephone: WARRINGTON 1901  
Telegrams: GREENINGS, WARRINGTON

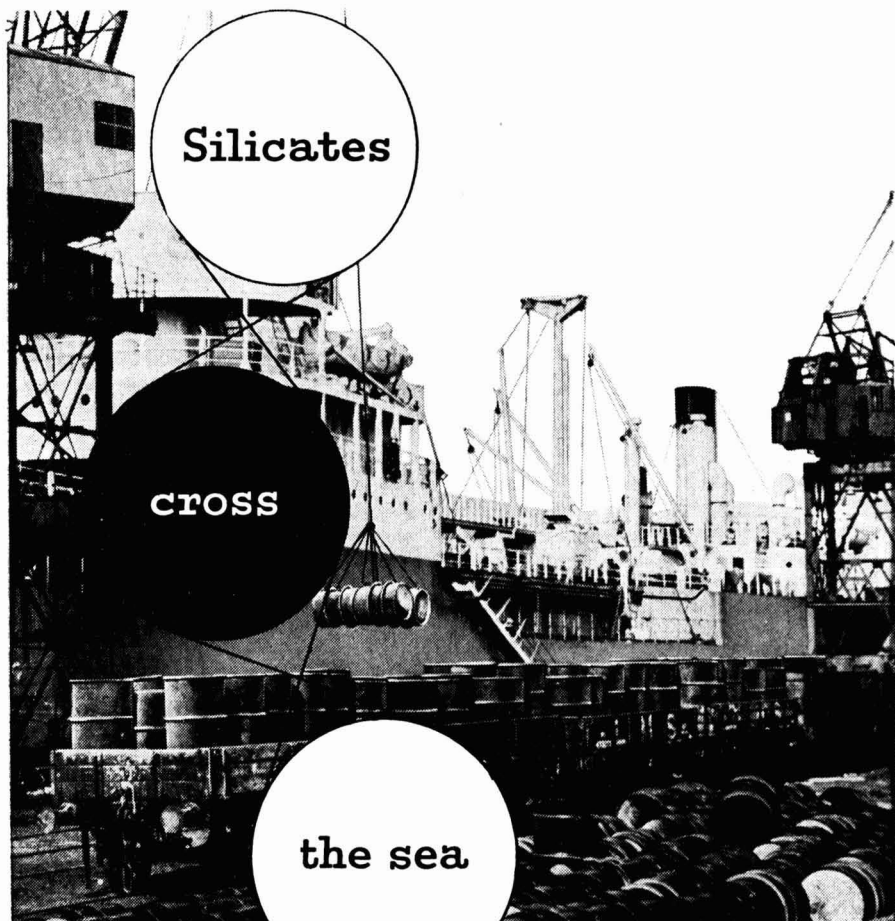

Photograph by Fenno Jacobs

Every year Crosfields sell thousands of tons of silicates and metasilicates to foreign countries, bringing valuable foreign currency to Britain—and bringing to users all over the world the benefit of Crosfields experience in the production and use of all kinds of silicate products. Export is a strong point where Crosfields are concerned. So if you need silicates and live far away—get in touch with Crosfields. (By the way, they'll be just as pleased to help if you live around the corner.)

Silicates for Industry

**Crosfield**

**JOSEPH CROSFIELD & SONS LIMITED, WARRINGTON, LANCASHIRE**

CSP4-19-100



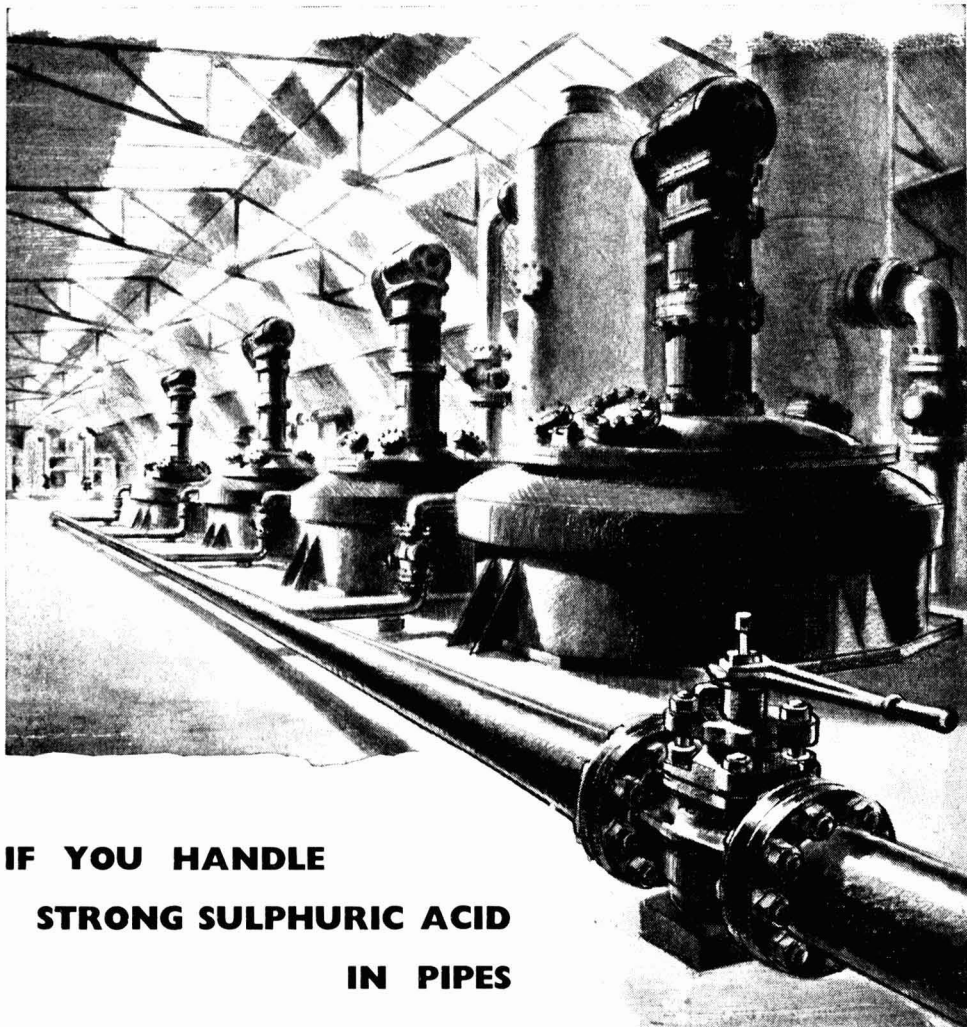

## IF YOU HANDLE STRONG SULPHURIC ACID IN PIPES

The combination of Audco Type S.R. Valves with Audco Lubricant 631 has given surprisingly good results in the handling of concentrated Sulphuric Acid. Troublesome sticking of the valves caused by the formation of sulphate scale has been virtually eliminated. Type S.R. seats in a well designed valve, allied to the lubricating properties, film strength and resistance of Lubricant 631 to both hot and cold acids, ensure absolute efficiency and dependable operation at all times.

For medium and low concentration, Audco Valves in Audcoloy, Reinforced Ebonite, Monel, Stainless Steel and Bronze are recommended. Our Technical Staff will be pleased to advise.

**AUDCO**  
*Lubricated*  
**VALVES**

*One lubricant for most valve services, plus grease gun lubrication, plus simple lubrication schedules, gives good valve performance and long life at low cost. This is made practicable by Audco Lubricant No. 631, a recent development now field proved. It has excellent lubricating properties, very wide temperature range and resistance to most pipeline fluids and gases.*

**Audley Engineering Co., Ltd., Newport, Shropshire**

# CERAMIC MEDIA FOR THE CHEMICAL INDUSTRIES

The development of "Celloton" and "Porsilex" ceramic materials may be largely attributed to the vast inter-war expansion of the chemical and food industries.

## CHARACTERISTICS

### "Celloton"

"Celloton" is essentially used in the form of ceramic diaphragms for electro chemical processes. It is available in four grades of porosity having the characteristics shown in the table below :

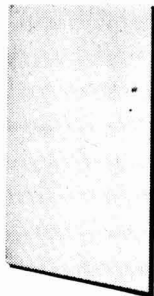

	CF18	CF26	HI25	HI94
Max. Pore Size in microns ...	6.1	3.5	1.3	1.4
Porosity ...	39.9	36.0	47.8	46.8
Permeability ...	3.0	2.5	1.9	2.0
Electrical Resistance Factor ...	5.6	7.0	3.3	3.4
Mechanical Resistance Kgs./mm.2	6.7	3.08	2.33	2.62
Thickness of Test Piece ...	3 mm.	3 mm.	3 mm.	3 mm.

Permeability=Volume in cc. passed by 100 sq. cms. per minute at 20°C. and a pressure of 10 cms. of water.

Elec. Resist. Factor =  $\frac{\text{Resistance of impregnated diaphragms}}{\text{Resistance of electrolyte of same dimensions}}$

It is available as flat plates (up to 30 in. square by 3 mm. thick), as tubes (open ended or closed), as boxed diaphragms, plates and discs in a variety of sizes.



### "Porsilex"

"Porsilex" is the ideal filtration and diffusion medium for innumerable purposes. Mechanically strong and durable, it is resistant to most corrosive fluids and possesses a high and regular pore density which is controlled in manufacture to provide a wide range of media available in the form of rectangular and circular tiles, discs and tubes.

## AEROX LIMITED

"Leaders in a Specialised Field"

Head Office and Porous Ceramic Works : Hillington Road, Glasgow, S.W.2

Phone : Halfway 2015 Grams : "Filters" Glasgow

Southern Office and Filter Works :

Crompton Way, Crawley, Sussex

Phone : Crawley 1277 Grams : "Aeromic" Crawley

# Advice about fire

It costs you nothing to consult Pyrene Fire Engineers about fire protection for your plant—yet it may result in the saving of thousands of pounds worth of equipment.

The wide experience of The Pyrene Company in developing specialised fire fighting appliances and installations for the Chemical Industries—including Pyrene Carbon Dioxide and CO<sub>2</sub> Dry Chemical Appliances for laboratories and similar risks, and Pyrene CO<sub>2</sub> or Mechanical Foam Installations for bulk storage of highly inflammable liquids or for process plant—is always at your disposal.

*If you wish to receive illustrated literature, or would like our technical representative to call, without obligation, write now to Dept. C.A.4, THE PYRENE COMPANY LTD., 9 GROSVENOR GARDENS, LONDON, S.W.1.*



**THE BEST KNOWN NAME IN FIRE PROTECTION**



**FATTY ACIDS**

*90% pure and low  
Iodine value*

The Distec technique of fractional distillation offers you a wide range of fatty acids of a purity unattainable by any other means. They can moreover be *tailored to your own specifications*. This may solve *your* problem—why not write to us about it? We'll be delighted to tell you how we can help.



Caprylic C7 H15 COOH  
 Capric C9 H19 COOH  
 Lauric C11 H23 COOH  
 Myristic C13 H27 COOH  
 Palmitic C15 H31 COOH  
 Stearic C17 H35 COOH  
 Behenic C21 H43 COOH

**also available:**

Caprylic-Capric, Stearine,  
 Mixed Unsaturated Acids,  
 Hardened Castor Oil



**FATTY ACIDS** pure because fractionated

*For fully descriptive catalogue, prices and samples, write to:*

**HESS PRODUCTS LTD 4 ALBION ST LEEDS 1. LEEDS 22827**

# T. DRYDEN LTD.

## Complete Laboratory Furnishers

*Chemicals and Acids for Laboratory and Industrial Purposes*

SCIENTIFIC GLASSWARE AND APPARATUS  
THERMOMETERS HIGHCLASS FURNISHING  
PHOTOGRAPHIC CHEMICALS & EQUIPMENT

SOUTH WALES STOCKIST and DISTRIBUTOR OF

PYREX, HYSIL and WOODS' GLASSWARE.  
WHATMAN, POSTLIP and GREENS' FILTER PAPERS.  
BAIRD & TATLOCK'S APPARATUS.  
ROYAL WORCESTER and DOULTON PORCELAIN.  
A. GALLENKAMP'S SPECIALITIES.  
FIRECLAY and VITREOSIL WARE.  
OERTLING & STANTON BALANCES.  
"ANALAR" ACIDS and CHEMICALS.  
BRITISH ROTOTHERM TEMPERATURE GAUGES.  
E-MIL VOLUMETRIC GLASSWARE and THERMOMETERS.  
"ALDIS" PROJECTORS, EPIDIASCOPES, Etc.

Phone : Swansea 55844/5

**LANDORE  
SWANSEA**

**J. F. Farwick & Co**  
LIMITED Est. 1809

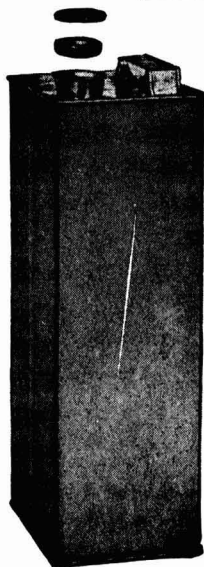

### IMPERIAL DOUBLE SEAMED SQUARE

Cans fitted with various types of necks, ranging from  $\frac{1}{4}$  pint to 1 gallon capacity.

### R.D. CONTAINERS

The fullway opening lever container comprising a special fitting plug easily removed, with a tabbed capsule covering to ensure a perfect sealing.

**208/214 YORK ROAD,  
BATTERSEA, LONDON,**

Telephone **S.W.11.** Telegrams  
Battersea 7008 Calorigen, Batt, London





# STANTON *Leadership*

The design and construction of every modern Precision Balance manifests the influence that STANTONS have exerted during the past few years.

**STANTON were first with:**

- Synthetic Sapphire (Corundum) Planes
- Full weight-loading balances in Britain
- Balances with a special application e.g. Gas Density Determination, Thermo Recording Work, Remote Control Work

**STANTON** *now present 2 new models*

## Model A.D.3.

Capacity : 200g.  
Sensitivity : 0.1mg. per  $\frac{1}{2}$  division

Reading from graticule screen in ideal position; stainless steel pans with spring loaded adjustable pan stops; selected agate knife edges; synthetic sapphire (corundum) planes; external weight loading up to 1g. no fraction weights required.

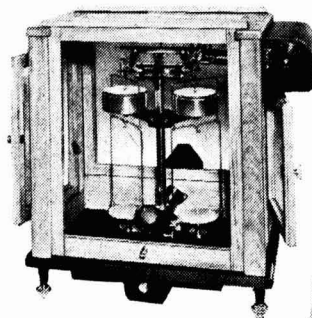

*Fully descriptive illustrated folder on request*

## Model B.A.9.

Capacity : 200g.  
Sensitivity : 0.1mg. per  $\frac{1}{2}$  division

Reading from ideally placed graticule screen; stainless steel pans with spring loaded adjustable pan stops; selected agate knife edges; synthetic sapphire (corundum) planes external weight loading up to 200g.; balance incorporating a set of stainless steel weights adjusted to NPL Class "A" tolerance.

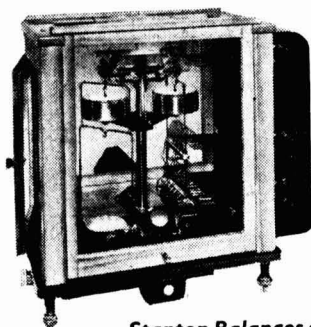

Stanton Balances are stocked by leading laboratory furnishers



**STANTON** PRECISION BALANCES

Stanton Instruments Ltd., 119 Oxford St., London, W.1. Gerrard 7533-4.

*This  
is the  
way to  
weigh—*

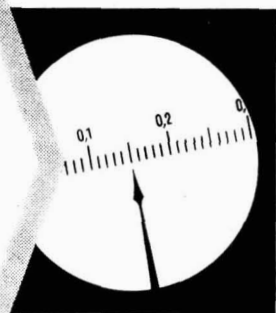

The Ultra Rapid Precision Balance really does "meet a long felt need." It shows the exact weight directly on an 8½" long scale, and a magnetic damping device brings the pointer to rest almost instantly. No more fiddling with fractional weights, no more waiting while Newton asserts his principle! Made in 6 sizes with capacities ranging from 200 to 10,000 grams. The perfect general purpose laboratory balance. May we send you details?

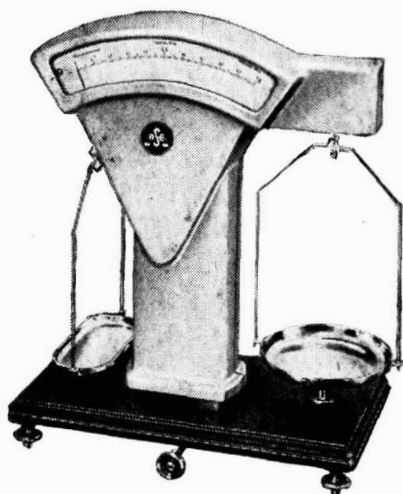

**SHANDON**

**SHANDON SCIENTIFIC COMPANY,  
6 CROMWELL PLACE, LONDON, S.W.7**

Phone: KNightsbridge 1131-3

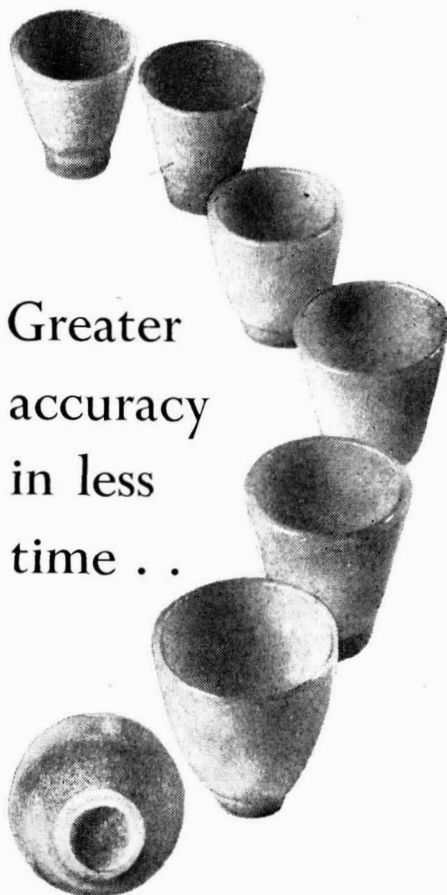

Greater  
accuracy  
in less  
time . .

By fusing Vitreosil porous discs into Vitreosil Filtering and Ignition Crucibles the need for preparing separate filtration mats is eliminated. Precipitates can be fired in the crucible up to 1050°C, and the whole analysis from filtration to final weighing can be carried out quickly and more accurately in the one crucible. Vitreosil filtering and ignition crucibles are available with discs in four grades of porosity.

**VITREOSIL**  
*pure fused silica*

LABORATORY WARE • INDUSTRIAL WARE  
• COOLING COILS • PROCESS PLANT

THE THERMAL SYNDICATE LIMITED  
WALLSEND • NORTHUMBERLAND

Telephone: Wallsend 63242

London: 12-14 Old Pye St., Westminster, S.W. 1.

# PHILIPS Electron Microscope

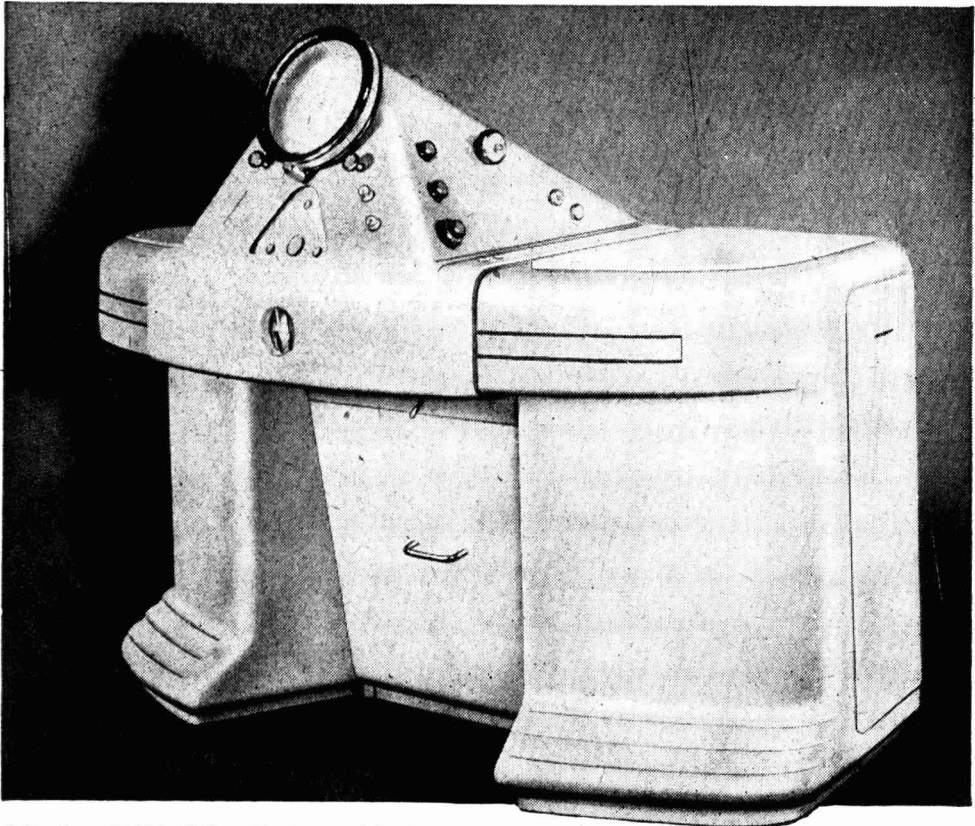

*A Product of N.V. Philips Gloeilampenfabrieken, Eindhoven, Holland*

- Acceleration voltage up to 100 kV.
- Magnification range continuously variable between 1,000 and 60,000 diameters.
- Photographic enlargement up to 150,000 diameters.
- Stereo-micrographs obtainable.
- Special self-sealing airlock for specimen holder.
- Film camera for obtaining micrographs.
- Focusing device and quick electronic alignment.
- Apertures adjustable and removable for cleaning without dismantling.
- Large *final* image screen of 8-in. diameter.
- Microscope tube not sensitive to vibration.
- No special foundations required.
- Suitable to work in any climate and at any altitude.



## PHILIPS ELECTRICAL

L I M I T E D

MAKERS OF: INDUSTRIAL X-RAY EQUIPMENT · ELECTRONIC APPARATUS · LAMPS & LIGHTING EQUIPMENT · ARC & RESISTANCE WELDING PLANT & ELECTRODES · SOUND AMPLIFYING INSTALLATIONS · MAGNETIC FILTERS · BATTERY CHARGERS & RECTIFIERS

X-RAY DEPT., CENTURY HOUSE, SHAFTESBURY AVENUE, LONDON, W.C.2.

(XB701B)

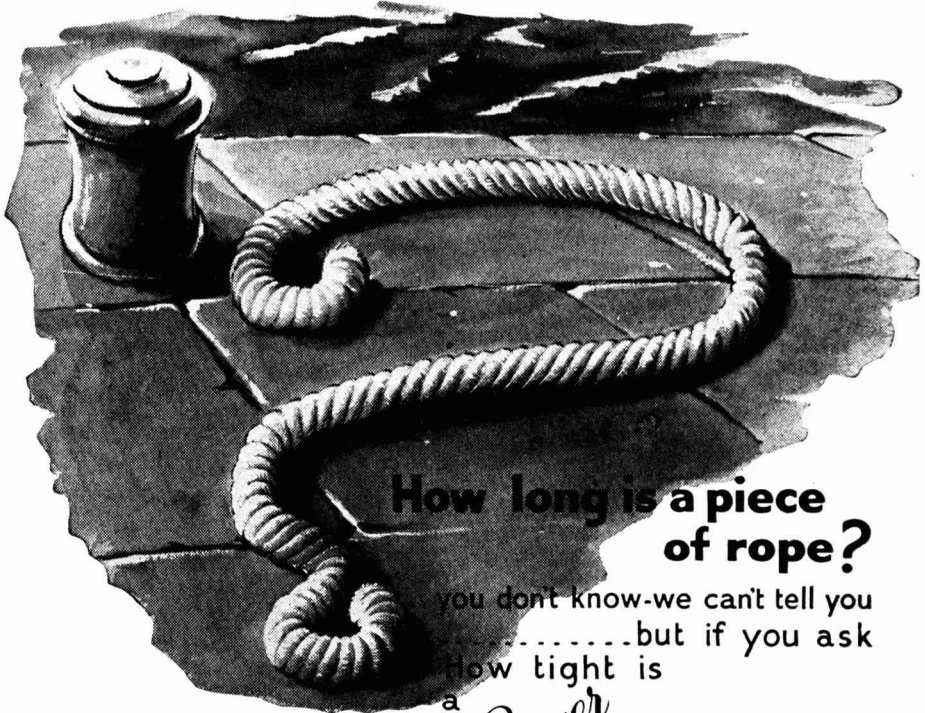

## How long is a piece of rope?

you don't know—we can't tell you  
..... but if you ask  
How tight is

a  
*Klinger*

**SLEEVE PACKED  
COCK**

we really do know

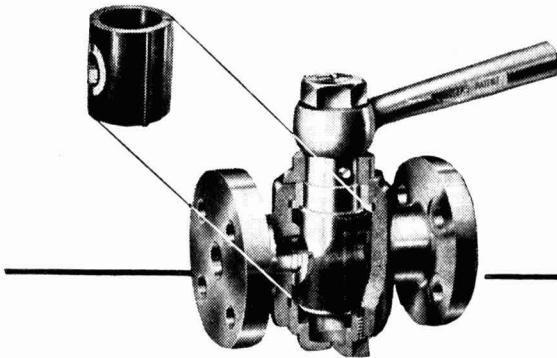

Write for the Klinger Master Catalogue which describes the complete range of Klinger products, compressed asbestos jointings for all purposes, valves, cocks, level gauges, synthetic and silicone rubbers.

**RICHARD KLINGER LIMITED**  
**KLINGERIT WORKS · SIDCUP · KENT**  
 Cables: Klingerit Telephone: Fooks Cray 3022  
 AGENTS THROUGHOUT THE WORLD



---

Volume LXX  
Number 1814

# The Chemical Age

Established 1919

*The Weekly Journal of Chemical Engineering and Industrial Chemistry*

---

BOUVERIE HOUSE · 154 FLEET STREET · LONDON · EC4

---

Telephone : CENTRAL 3212 (26 lines)

Telegrams : ALLANGAS · FLEET · LONDON

## CONTENTS · 17 APRIL 1954

Trade in Radiation	877
New Laboratory for NPL	881
Clothes Storage	884
Water Pollution Research	885
Sulphuric Acid Output	888
Comparative Studies in Gallium Chemistry	889
New Automatic Packaged Boiler	891
Lack of Science Teachers	892
The Chemist's Bookshelf	893
Resignations Sought	895
Home News Items	896
Overseas News Items	897
Personal	898
Publications & Announcements	899
Law & Company News	901
Next Week's Events	902
Market Reports	902

---

Editor : E. A. Running

Publisher & Manager : John Vestey

MIDLANDS OFFICE :  
Daimler House, Paradise  
Street, Birmingham

Phone : Midland 0784/5

SCOTTISH OFFICE :  
116, Hope Street,  
Glasgow, C.2.

Phone : Central 3954/5

LEEDS OFFICE :  
Martins Bank Chambers,  
Park Row, Leeds, 1

Phone : Leeds 22601

SINGLE COPY 1/- (BY POST 1/3)

ANNUAL SUBSCRIPTION 42/-

*"Geryk"* - all British

**VACUUM PUMPS**  
FOR FACTORY OR LABORATORY PURPOSES

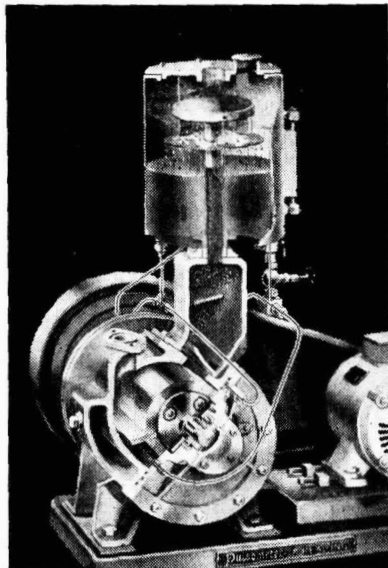

All Types and Sizes for  
All Duties

**Wet and Dry Pumps**

**Reciprocating and Rotary**

**Single and Two-stage  
High Vacuum Pumps**

List No. 3342

**Pulsometer Engineering Co. Ltd.**  
Nine Elms Ironworks, Reading.

# BRITISH TAR PRODUCTS

LIMITED

Makers of

PYRIDINE

PHENOL

CRESYLIC ACIDS

META-CRESOL

NAPHTHALENE

TOLUOLE

ANTHRACENE OIL

SOLVENT NAPHTHA

XYLOLE

ORTHO CRESOL

METHYL CYCLOHEXANOL

CYCLOHEXANOL

SALES OFFICE :

418<sup>A</sup> GLOSSOP ROAD, **SHEFFIELD, 10**

Telephone: 60078-9

Telegrams : " CRESOL, SHEFFIELD; 10 "

---

## 'Perfluoro' Progress

---

IT was rather more than two years ago that our leader drew attention to the new chapter in industrial chemistry that was being opened by the fluorocarbon compounds (see CHEMICAL AGE, 1952, 66, 429). Despite the individual reactivity of carbon and fluorine as elements, their combination in organic molecular patterns leads to materials of exceptional stability. Today, the easier name 'fluorocarbons' seems to have lost a little favour; these compounds are usually denoted by the prefix perfluoro-, e.g. the displacement of hydrogen in acetone ( $\text{CH}_3\text{COCH}_3$ ) by fluorine to make  $\text{CF}_3\text{COCF}_3$  gives us 'perfluoroacetone.' This is more precise and systematic nomenclature but we hope, nevertheless, that the generic name will remain 'fluorocarbons' and not gradually become 'the perfluoros.'

We observed two years ago that 'it seems safe to predict that many more fluorocarbons will be preparable than the silicon analogues of carbon compounds' and time has swiftly justified this suggestion. As a broad generalisation, all hydrogen atoms in organic compounds can be replaced by fluorine atoms. Perfluoro-chemistry might be looked upon as a photographic representation of organic chemistry. Furthermore, it is possible to prepare compounds in which some of the hydrogen atoms have been replaced by other halogens so that still another range of substances—the 'fluorohalocarbons'—can achieve a new and synthetic existence. With fluorine, man has indeed become a versatile maker of new molecules, and several fields of practical utilisation have become markedly visible—high temperature lubrication, heat transfer and refrigerant use, and chemically inert plastics.

The wartime need for a stable and non-reactive substance that would mix inertly with uranium hexafluoride was

dealt with previously; indeed, more than one new fluorocarbon substance was required for the development of the first atomic bomb. Since then, however, much cheaper methods of preparation than direct C-F interaction have become available, notably the cold electrochemical process wherein the analogous organic compound is dissolved in the anhydrous hydrofluoric acid of the fluorine electrolysis cell. In addition, two fluorinating agents have become more widely and cheaply available, cobalt trifluoride and chlorine trifluoride. It is certain that fluorine's invasion of organic chemistry would have remained an academic curiosity and a costly necessity of atomic projects but for great progress in the production of commercial fluorine. All the perfluoro-development and all its new potentialities rest upon inorganic and electrochemical advances.

The modern fluorine cell is a very different apparatus from Moissan's original of the late 19th century. The expensive need for alloys of platinum and iridium has gone. Although it was quite quickly found that copper or nickel could replace the alloy for cell-wall construction, modern cells are now constructed of mild steel with cathodes of sheet steel and anodes of graphite. Gone, too, is the need for refrigeration; Moissan had to create a working temperature of  $-30^\circ$  to  $-50^\circ$  but today's cells, using fused potassium hydrogen fluoride containing up to 40 per cent HF, run at an electrolysis temperature of about  $100^\circ$ . These steady rather than sudden developments in the fluorine-producing cell have made relatively cheap and bulk-produced fluorine possible. However, the use of active fluorinating agents preparable from the element must always be a second-choice commercial route to the new perfluoro-

compounds. The cold electrolytic process based on hydrofluoric acid is cheaper and usually involves more docile reactions. In a sense, therefore, fluorine progress has turned back upon itself, and the electrochemical advances that first made the element cheaply available have led also to the electrolytic cell method for making organic compounds of fluorine without directly using the element.

Atomic projects no longer monopolise the need for fluorocarbon oils or greases. Jet propulsion has created many new demands for high temperature lubricants, and there has been a small-ranged choice between the silicones and the fluorocarbons. We suggested in 1952 that 'quite often the fluorocarbon will possess the greater stability,' and it would now appear to be true that under severe conditions fluorocarbon lubricants maintain their chemical inertia more reliably than silicones. Moderate chain-length polymerisation of the simpler perfluorohydrocarbons produces high temperature lubricants of better stability than the perfluorination of higher paraffins. It would be easy to pass by this example of multi-synthesis as a normal development of modern chemistry, but it surely deserves special recognition. First, entirely new monomeric molecules have been prepared giving rise to a range of substances with new combinations of useful properties. Then, and within only a few years, it has been found that better combinations of these useful properties can be obtained by polymerising the simpler monomers. Are there so many parallels to this synthesis-upon-synthesis achievement that we should take it for granted? Atomic and jet-flying man has had to make explorations well beyond the realm of mineral and natural substances to achieve his new powers over force and space. Whether this will bring progress or regress for civilisation is another matter and not on our present agenda. It can only be hoped that the vital contribution of perfluoro-chemistry to atomic and jet propulsion development will prove peaceful and beneficial rather than catastrophic.

In the refrigerant and heat transfer field fluorocarbons are well established.  $\text{CCl}_2\text{F}_2$ , the original 'Freon,' is no

longer a lone member of its family, and there is today a range of these non-corrosive, non-toxic, odourless and inflammable substances from  $\text{CHFCl}_2$  to  $\text{CF}_3\text{CH}_2\text{Cl}$  whose boiling points differ by  $180^\circ$ . Freeze-drying has added to the demand, and it is perhaps a possibility of the future that the development of the heat-pump will also call for quantities of fluorocarbon heat transfer fluids.

Plastic polymers made from the monomeric 'Freons' have also gained industrial foothold, and they will probably be better known under the names of 'Teflon' or 'Fluon.'  $(\text{CF}_2 = \text{CF}_2)_n$  is relatively simply made from the 'Freon' series. It is a crystalline material of remarkable chemical stability, immune to the most pressing attentions of organic solvents, alkalis and acids. Not even HF affects it. Its plasticity is not all that might be desired but for special corrosion-resisting tasks the mechanical difficulties of working the material into shape are minor compared with the value of such unique chemical inertia. More amenable to moulding but slightly less inert and electrically resistant is 'Fluorothene,' the polymer built up from perfluorovinyl chloride,  $\text{C}_2\text{ClF}_3$ . In this field we are possibly only at the beginning for we must suppose that all perfluoro-compounds containing a double bond are theoretically polymerisable. However, materials such as these are always likely to be costly compared with the ordinary organic polymers.

'Fluorine is probably the most active element known . . . No compound with chlorine is known.' These are two sentences from a highly respected text-book of just over 25 years ago. The first is still admissible, the second out-dated. Yet the more we plunge into fluorine's chemistry, the more we find that this highly active element confers immense stability upon so many of the molecules it enters. It is fluorine in mineral rock phosphate that makes this geo-complex a relatively unavailable form of phosphate. It is fluorine as fluorides in water that brings stability to the stuff of teeth. And it is fluorine in organic molecules that brings us high-temperature oils and non-inflammable liquid refrigerants and plastic polymers that defeat all forms of chemical attack.



## Notes & Comments

### CIL Partition

**B**EFORE the end of this month shareholders in Canadian Industries Ltd. are expected to approve a partition of the joint ICI and Du Pont interests, at present amounting to 83.6 per cent of the common stock. It is a separation made necessary by a 1952 antitrust order by a United States court. The two resultant companies will be Canadian Industries (1954) Ltd., in which ICI will hold 82.3 per cent of the stock, and Du Pont of Canada Ltd., in which Du Pont will hold a similar majority of the stock. The minority of shareholders in CIL will become shareholders in the two new companies, each \$100 holding being converted into a \$50 holding in each of the companies; in addition they will receive a one-tenth addition to their holding, a 'bonus' offering that will not apply to the ICI or Du Pont shares in CIL stock. There seems little doubt that this rearrangement of ownership and control will satisfy everybody concerned.

### Division of Assets

**T**HE division of assets is a far more cumbersome operation. CIL 1954 will take over agricultural chemicals, chemicals, explosives, ammunition, paints and coated fabrics and plastic departments. This involves some 20 of the present CIL plants. The new Du Pont company will take over films, textile fibres including nylon and Cellophane, and sheeting and tubing manufacture from polythene resin flake. Polythene resin flake, however, will be made by CIL 1954 as this goes with their take-over of plastics. It remains to be seen whether the new companies will eventually compete in particular fields. It has already been commented in America that paint may be one field of direct competition though the evidence for this—the fact that Du Pont regain their former paint brand name of Duco—seems somewhat slender. Competition is an unpredictable possibility, as unpredictable as chemical industry developments in 10 or 15 years'

time. Either company presumably may develop an entirely new product that will compete in its utilisation with an existent product of the other company. Monopoly, using that volatile word to mean the inverse of competition, does not, with chemicals, begin and end on paper. History shows only too emphatically that monopolies can begin by chance or arrangement but end abruptly in the research laboratory. It is pleasant to find that the British portion after the subdivision will carry on the name of Canadian Industries with all the CIL trademarks. In this there would seem some recognition of the sentimental rights of Canada's mother-country.

### Pests & Poisons

**A**NEW trade publication from one of the leading British agricultural chemical companies, dealing exclusively with the troubles that may beset the grower of hops, makes those outside this ever-advancing field of technology realise how complex the problems of crop control have become. By far the most serious attack that may be made upon hops is that of the hop aphid and known not too accurately as 'black blight.' In the past, frequent dustings or sprayings with quassia or nicotine were required; now with the development of the organophosphorus insecticides much less frequent treatment brings surer control. But these new substances are much more dangerous to handle, whether the systemic plant-absorbed variety or the mainly contact-acting parathion are used. Their application is legally controlled, with statutory obligations under the Agriculture (Poisonous Substances) Regulations 1953. For this reason an alternative programme of hop aphid control is offered, one that is based upon gamma-BHC and involving no special precautions such as the use of protective clothing. Nevertheless, it is clearly and fairly pointed out by the manufacturers that this alternative treatment will not only cost more, but will be less efficient.

## Contract Spraying

THE answer to any dilemma thus presented to the smaller grower is given by the modern contract spraying service. Only a few days ago a small tomato grower in one of Britain's foremost centres for this crop told us in conversation that he himself no longer bothered about spraying work. At intervals he called in a contractor who thoroughly filled his houses with highly effective but also highly toxic insecticide; pests and their eggs were disposed of in the same operation. The requirements of modern legislation were fulfilled by the contractor and his staff. In any centre for specialised cropping there must be steadily expanding opportunity for such services. The expert in application can stand between the chemical manufacturer and the grower and ensure that these efficient but hazardous modern substances are applied without risk. It seems preferable to choosing less hazardous insecticides whose cost is greater and whose specific efficiency is less. Ideally, of course, we need insecticides that are fully effective but free from toxic hazards in use, but for many of the most serious plant affections these substances, natural or synthetic, do not exist.

## IN THE EDITOR'S POST

### Old Industrial Customs

SIR.—May I seek through your columns the help of your readers in what I hope may prove an interesting study. For a long time I have held that many of the day-to-day happenings and misunderstandings in our factories, shipyards, mills and mines are due not to immediate causes, but to far-off events, customs, traditions and superstitions. To give but one example—the antagonism that is sometimes revealed between the manual and 'black-coated' workers is not, as often supposed, of modern origin. Professor Gordon Childe, in 'What Happened in History,' records that:—

'A late Egyptian papyrus in the form of a father's advice to his son contrasts the prospects of a clerk who may "become an official of high rank," and will be "exempt from all manual tasks" with the position of a metal worker, "with fingers

like a crocodile's," of a mason and of other craftsmen.'

Whereas much is known of the origins of common daily superstitions—not passing under a ladder; turning money at the new moon; not marrying on a Friday, etc—little appears to have been recorded of old notions and customs that still linger on in industry. And, having used this word 'industry', can any of your readers inform me when it was first used to denote those collective activities associated with the winning, fashioning and, to some extent, the marketing, of earth's raw material?

I shall be most grateful for any information that may result from your kindness in publishing this note.—Yours, etc.,

ROBERT HYDE.

'Gleivering,' Beech Road,  
Haslemere, Surrey.

[Sir Robert Hyde, K.B.E., was the founder and lately director of the Industrial Welfare Society.—ED.]

## ICE Annual Meeting

PROGRAMMES have now been issued for the 32nd annual corporate meeting of the Institution of Chemical Engineers which is to be held at the May Fair Hotel, Berkeley Street, London, W.1, on Friday, 30 April.

Under the chairmanship of the president, Mr. Stanley Robson, the meeting will begin in the garden suite at 11 a.m., and in addition to the customary business the Osborne Reynolds Medal and the Moulton Medal will be presented. Mr. Robson will give his presidential address at noon, his subject being 'Progress & Objectives.'

Sir John Cockcroft, director of the Atomic Energy Research Establishment, Harwell, will be the principal guest at the annual dinner which will be held in the ballroom, beginning at 7 p.m. for 7.30 p.m. Numerous other distinguished guests will be there, including presidents of kindred institutions and societies. Members are being invited to bring ladies and other guests up to a limit of three per member. Tickets cost 30s. each. So that adequate arrangements can be made, those desiring to participate are asked to notify the Institution not later than 20 April.

# Trade in Radiation

## Some Details of an Expanding British Industry

**B**USINESS in British radiochemicals in 1953 was more than six times what it was in 1948, and is growing rapidly. Four new buildings at the Radiochemical Centre, Amersham, built to raise production from the test-tube and beaker to the pilot-plant scale, were opened by Sir Henry Dale, O.M., F.R.S., on 8 April. Designed and constructed by the Ministry of Works to the requirements of the Centre's chemists and engineers, the new buildings are the first in this country specially laid out for the accommodation of isotope production processes.

To mark the occasion of the opening, Sir Henry operated remote control mechanisms to seal a bottle containing radioactive phosphorus. Among those present at the opening were the Lord President of the Council (Lord Salisbury), Sir John Cockcroft (director of the Atomic Energy Research Establishment, Harwell), Sir Ernest Rock Carling (Home Office), Sir Charles Harington (director of the National Institute for Medical Research), Sir Donald Perrott (secretary to the Department of Atomic Energy), Professor W. V. Mayneord (Royal Cancer Hospital), Major G. Boyce (chairman of the Amersham Rural District Council), Doctor Henry Seligman (head of the

Isotopes Division at Harwell), Doctor P. Grove (manager of the Radiochemical Centre), and others.

Sir Henry recalled that during the war this centre under Doctor Grove had recovered important quantities of radium for use in the war efforts when supplies from Belgium were cut off. It was then known as Thorium Limited, and a secret Cabinet committee, of which Sir Henry was chairman, decided that because of the great prospective new wealth of radio isotopes which were going to become available for research, medical treatment and other purposes, the government should acquire the centre.

The very substantial quantity of radioactive isotopes which has come from Harwell and Amersham in recent years has mostly been produced in simple laboratory apparatus, requiring considerable direct manipulation, and housed in general purpose buildings. The demand has now so far increased that for several of the more important isotopes it has become necessary to construct individual chemical plants, completely screened and remotely operated, and to install them in buildings designed for the purpose. Improved facilities for dispensing, packing and dispatching the products are also included.

*The new units at Amersham; the wooden glass-fronted structures over the vestibules house the air-conditioning plant. In the foreground can be seen one of the jacking trolleys used for the transport of small quantities of radioactive material, while the tractor in the background is moving a larger quantity*

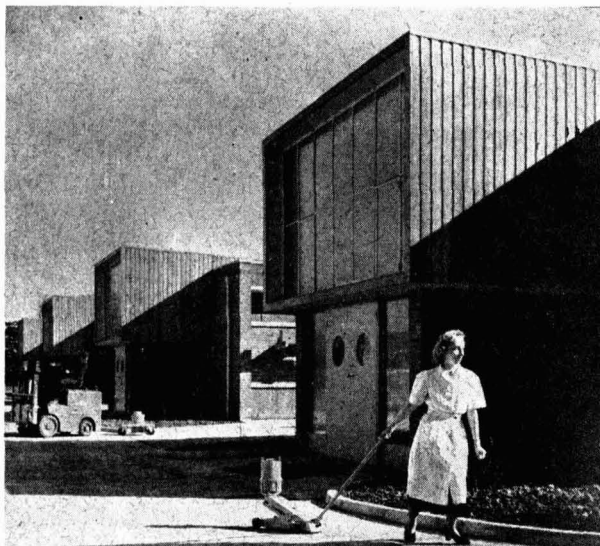

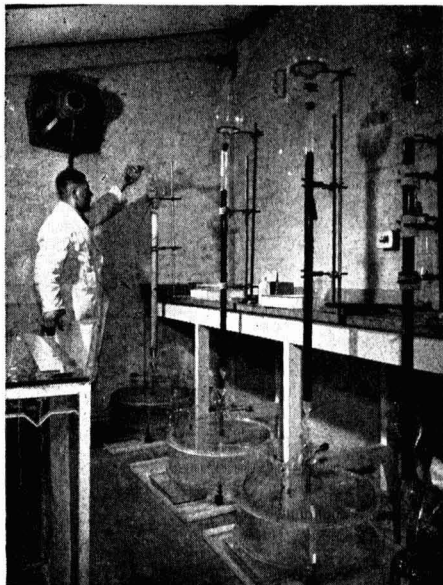

*The separation of active amino-acids from the protein hydrolysate is carried out by column chromatography. To separate the seventeen amino-acids about 2,000 fractions have to be collected by means of automatic collectors*

The building scheme provides for an eventual eight buildings, each to be used for a group of processes of a similar character. The four buildings so far constructed consist each of a single room with a floor area of 900 sq. ft., completely clear of permanent fittings. All necessary services are provided in overhead ducts, emerging through the ceiling at intervals to serve six production units in each room. Air conditioning plant is situated in a glass-fronted unit over the vestibule of each building, and special drainage is provided for radioactive effluent.

The buildings are separated well from one another, so as to reduce the radiation field between them, and to allow access for heavy vehicles carrying supplies of radioactive raw materials.

Installation of the chemical production plants has been going on for about six months and is nearly half completed; five units are in operation. The laboratory processes which have hitherto been employed for the separation of isotopes would involve danger to health if employed on a larger scale, and it has been necessary to develop new methods which are basically suited to remote control. The design of each plant

has had to meet the following requirements: complete screening against radiation; avoidance of any direct handling of active materials; and effective control of gaseous, liquid and solid effluent.

Screening is provided against  $\gamma$ -emitters by 4 in. of lead bricks, 6 in. of lead glass brick, or 18 in. of concrete, and against  $\beta$ -emitters by  $\frac{1}{2}$  in. asbestos or Perspex. All equipment which may become radioactive is contained in sealed compartments, so that if future modifications are required, each plant can be dismantled without interference with the structure of the building.

Manipulation of apparatus within the units is by means of remote handling tongs. These are mounted on long steel rods sealed through the front wall of the unit by large ball and cup joints, and a trigger action moves the sprung jaws open or shut at the end of the rods. Various cranes and railways are also used where necessary. To move active material in small quantities outside the screening walls of the unit, Perspex air-lock boxes are employed. Larger quantities are moved in lead-shielded trolleys. Most of the handling equipment has been constructed in the Centre's workshops to designs by Harwell.

The products of the Centre fall into two classes: radiation sources and labelled compounds; there are some 20 different isotopes and several hundred compounds described in the price list 'Radioactive Materials,' published last year.

The most versatile single isotope, and one of the first with which the Centre concerned itself, is Carbon-14. Aluminium nitride is prepared at Amersham, sealed in aluminium cans, and irradiated for about a year in the production piles at Windscale. Some of the nitrogen-14 is thus converted into carbon-14, and the active material is returned to Amersham. Owing to the long period of irradiation and the need to devise a target material which will withstand the vigorous conditions in the pile, the building-up of stocks of carbon-14 has taken a considerable time; annual production is now sufficient to meet the demand (about 10 c. per annum).

The initial form in which carbon-14 is used, as  $^{14}\text{CO}_2$ , is of only limited interest, but it makes a convenient starting-point for organic synthesis. Under Dr. J. R. Catch, the organic group has during the past five years prepared over 100 compounds by chemical methods. A typical product is



labelled glycerol,  $^{14}\text{CH}_2\text{OH}\cdot\text{CHOH}\cdot\text{CH}_2\text{OH}$ , which is produced at the rate of about 1 gm. per year, at an activity of 10 mc. and a cost of £2,000.

Increasing use is being made of biological methods. Sugars uniformly labelled may be obtained by photosynthesis in tobacco or canna leaves grown in  $^{14}\text{CO}_2$ ; specifically labelled sugars are obtained by chemical methods.

More recently the common green alga, *Chlorella vulgaris*, has been grown very successfully in rotating bottles under a bright light to produce plant protein uniformly labelled. All the amino-acids produced by hydrolysis of this protein will be labelled at every carbon atom, since the algae have been supplied only with labelled carbon dioxide, and they may be separated by chromatography.

An interesting example of the uses to which these highly active amino acids may be put is that of the 'radioactive egg.' A hen at the National Institute of Medical Research was fed with 3 mc. of protein (at a cost of £300); a large proportion of this activity turned up in one of the eggs subsequently laid, in the form of labelled albumen. It is expected that the future will see many adaptations of this method.

The two isotopes in greatest demand for medical purposes are iodine-131 and phosphorus-32, and these are commonly employed in the simple form in which they are first extracted.

Both these isotopes are separated in one of the new buildings, where units for the

separation of radiogold, sodium-22, sulphur-35, and iron-55 and -59 will also eventually be erected. For the production of iodine-131, tellurium in a silicon container is irradiated in BEPO for about two weeks. As much as possible, chemical extraction methods have been avoided, and the iodine is removed by dry distillation into dilute caustic soda. This requires only simple heating, and can be controlled by automatic instruments. After about two days all the iodine has been removed, and the tellurium can be returned to BEPO for further irradiation. The particular advantage of this cyclic process is that any unwanted volatile impurities will be removed during the first distillation, and the products become steadily purer.

About 2-3 c. are obtained in the distillate each time. The solution in the absorbers is assayed and then passed to the dispensary, where it is sub-divided into required amounts. Since iodine is a  $\gamma$ -emitter, the whole unit is enclosed in 4 in. lead or 18 in. concrete.

Phosphorus-32 is produced similarly from sulphur, and again the method is cyclic. In this case, however, the sulphur is distilled off and the phosphorus left as residue. Any residual sulphur is removed, and the phosphorus at the same time brought into solution, by refluxing with dilute HCl and  $\text{H}_2\text{O}_2$ . Phosphorus is a  $\beta$ -emitter and is only enclosed in asbestos and Perspex.

In an adjacent building, uranium fission products are separated. Waste solutions of fission products are received from the atomic

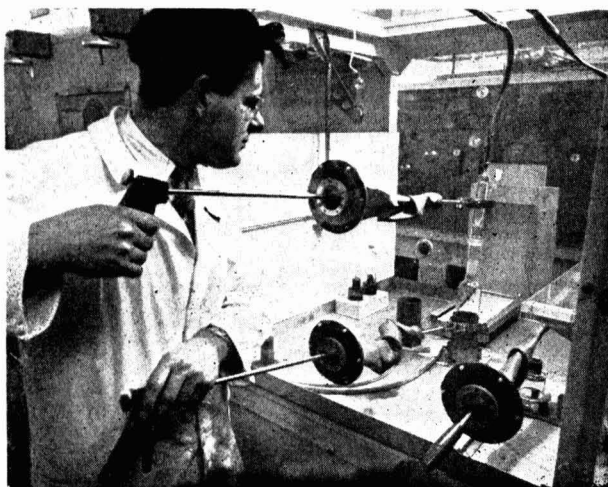

*Final reflux stage in separation of radioactive phosphorus from sulphur. The chemist is operating his remote controls protected by a sheet of Perspex*

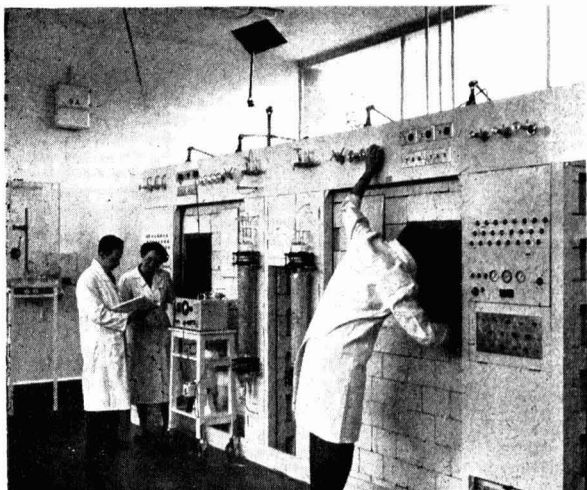

*Separation plant for strontium-90 and caesium 137, screened by nearly two feet of concrete and operated entirely by remote control. Mirrors over the top of the units enable the processes inside to be observed*

factories at Windscale and Springfields, and so far methods have been developed of extracting strontium-90 and caesium-137. It is hoped that further methods of extraction and further uses for other isotopes will be developed, since the solutions are highly radioactive and disposal is costly.

Both the isotopes extracted at the moment have industrial applications, due to their long half-life: strontium-90 (20 years) is used for thickness gauges, static eliminators, skin radiation and luminous compounds; and caesium-137 (33 years) is employed in industrial radiography.

Strontium is separated by precipitation from nitric acid; the normal batch quantity is about 13 mg. (20 c. of fission products and 2 c. of strontium). Caesium is precipitated as the phosphotungstate, a normal batch being about 130 mg. (100 c. fission products, 10 c. caesium). Both are very active  $\gamma$ -emitters and are screened with 4 in. lead bricks and viewed through a 6 in. lead glass window. Solutions are moved and filtered by alternate sucking and blowing mechanisms, with glass beads as non-return valves, and small quantities of solution are moved about in Perspex air-lock boxes.

So that these fission products can be generally useful in industrial applications, it is most important that they should be incorporated in forms safe and convenient to use. Considerable effort has therefore been devoted to producing radiation sources in standard physical forms. Silver foils containing strontium-90 are now widely used in industry.

Until 1949 nearly all the work carried out at Amersham was with the natural radioactive elements, and there is still considerable academic interest in the elements themselves, and the medical requirements for radon seeds and radium needles have in fact increased. During the last five years about 12,500 radium needles and 164,000 radon seeds have been manufactured at the Centre, and particular care has been taken to maintain their quality.

Business has boomed indeed during the past five years, rising from some £38,000 in 1949 to more than £114,000 last year. About 36 per cent of this was exported (sterling 3 per cent, dollars 14 per cent, other currencies 19 per cent) and consignments were made to 36 countries. The principal customers were the US, Canada, Germany, France and Sweden. During last month over 1,000 deliveries were made from Amersham; this sharp increase over previous figures was partly due to the transfer of iodine and phosphorus business from the Isotope Division at Harwell, but the growth in demand continues steadily.

#### **Southern Rhodesia Cement Works**

A new cement works for Salisbury, Southern Rhodesia, is to be sponsored by Associated Portland Cement Manufacturers. Investigations have shown that cement-making materials exist in suitable quality and quantity close to Salisbury. The works will be designed to produce 120,000 tons of cement a year. Capital expenditure required is estimated at £1,500,000.

# New Laboratory for NPL

*First in Nearly 20 Years*

IN 1928, plans were discussed at the National Physical Laboratory for the construction of a new building opposite what is now the Duplex Tunnel Building; they came to nothing. Last week, on 6 April, the new Metallurgical Building, on the same site but about half the size of the previously-projected building, was opened by Sir Lawrence Bragg, a former Director of NPL. Nevertheless, as Sir Edward Bullard, the present director, pointed out in his introductory speech, this was the first new building (as distinct from wind tunnels) since the photometry building in 1936, and he hoped it would be the first of several.

Anyone who had worked in a laboratory more than 40 years old, he said, must have wished heartily that it could have been burnt down; the design of the new laboratories, therefore, had been made as flexible as possible. On the upper floor of the building rooms were separated by light partitions which could be removed in a few hours. The design was by the Ministry of Works architects, who had proved very adaptable, and he hoped that in the future more and more laboratories would be built on the same shell principle.

Introducing Sir Lawrence Bragg, Sir Edward said that no one more suitable could have been chosen for the opening ceremony,

and Sir Lawrence had needed very little persuasion to come. It could truly be said that within his lifetime a complete new science, that of X-ray crystallography, had come into being. They were also fortunate in the presence of Lady Bragg, who, unfortunately, would not make a speech. He presented her with something both ceramic and metallic, a piece of costume jewellery made by Lady Bullard.

Sir Lawrence said that the metallurgical division had a great tradition to live up to. It was remarkable how much of the pioneer work on the structure of metals was English; not only the development of X-ray metallography, but the theories of order and disorder in metals. Of course, most theories of metal structure (except his own!) were pure waffle, but one day some genius would clear up the whole subject of metal physics.

He thought it imperative that NPL should not only keep standards but set them. It was the place which should know the best and be in a position to use it. He was therefore sure that the X-ray laboratory would be a model of its kind, and he wished it all good luck.

Dr. N. P. Allen, Superintendent of the Metallurgy Division, presenting the key of the new building to Sir Lawrence, said it had been specially designed to represent

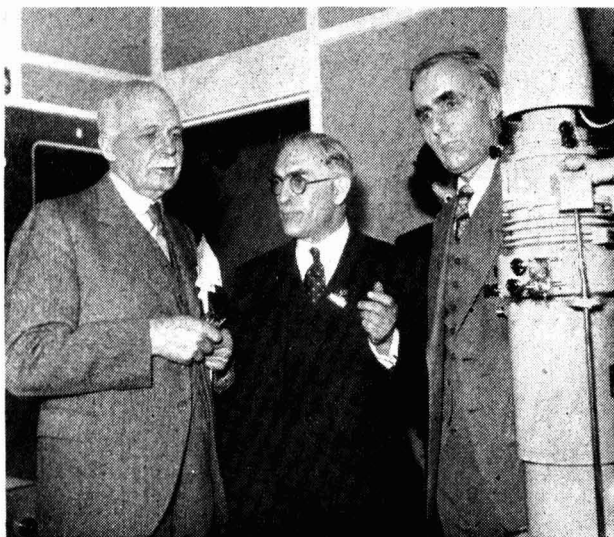

*Sir Lawrence Bragg, Dr. N. P. Allen and Sir Edward Bullard discuss an electron microscope in the X-ray laboratory*

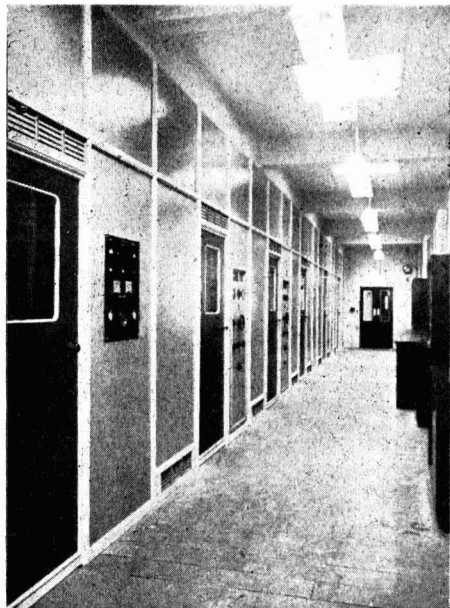

***The main X-ray laboratory, showing on the left separate cubicles each containing one diffraction unit***

many past and present activities of the division. Made by Mr. Glaysher, who was in his 40th year with the laboratory, it was of titanium, melted and forged in the laboratory, and engraved and pierced at the Royal Mint. An inserted piece of gold brought together the oldest and newest of the commercial metals.

The yellow piece at the bottom of the stem was of aluminium bronze, a product of the early researches of Sir Harold Carpenter, the first superintendent. The first ring was of Y alloy, recalling the development of aluminium alloys during the first world war and the researches into age-hardening carried out when Sir Lawrence was director.

NPL pure iron constituted the second ring; and the third was of iron-nickel-tungsten alloy, the result of work on heat resisting alloys and the phenomenon of creep at high temperatures. The fourth ring was of uranium, on which NPL had carried out research during the early part of the war.

A piece of silver in the middle of the key symbolised the present work on solid solutions, and the red metal at the end was 15 per cent gold in copper, used in the study of solid solutions by X-ray line intensities.

The new building has been made necessary by the development of techniques for the examination of the fine structure of metals and the growth of interest in the properties of materials at very high temperatures. It consists of two storeys with a total floor area of 11,700 sq. ft., of which about 5,800 sq. ft. is experimental working space, to accommodate the ceramics section, the X-ray section and a new radioactive tracer section.

The ceramics section is on the ground floor, and consists of five laboratories and offices and a furnace room. This room contains a large natural draught recuperative gas-furnace, capable of reaching temperatures of 1,800°, and firing on a considerable scale will be possible.

Among work carried out in the ceramics section will be the comparison of tensile strengths of fused tubing above 1,800°, part of the research being done in the development of rocket propulsion; and the manufacture of very fine alumina tubes for platinum/platinum-rhodium thermocouples.

Also on the ground floor is the radioactive section, where tracer techniques are applied to metallurgical problems; one of the first investigations will be concerned with phosphorus in iron. This section is provided with air conditioning and drainage entirely separate from the rest of the building.

#### **Precautions against Contamination**

The whole section is approached through an air lock, a warning buzzer based on a differential pressure gauge giving notice of anyone's entry. Precautions have been taken to ensure that radioactive material cannot be carried to any other part of the building to upset the electronic counters in the X-ray section: all workers in the tracer laboratory are required to change and take a shower before leaving; a slightly low pressure is maintained within the section so that no air leaves except by filters; and a slightly high pressure is maintained in the rest of the building.

All rooms have been designed so that they may be sluiced down; all waste water is run to delay tanks until its activity is below the MRC limit; the air filters remove particles down to a diameter of 2  $\mu$ ; and the exhaust trunk is monitored to make sure that active material is not vented to the atmosphere. A lead-lined safe is fitted with a door on the outside of the building, so

that deliveries of active material may be made at any time in 24 hours.

The upper floor is designed for X-ray diffraction studies of metals and for electron microscopy, and replaces three small rooms in the main metallurgy building. Except for three offices and one laboratory, it consists of a single large room 66 ft. by 44 ft., which can be divided into a number of cubicles, each of which is intended to contain a single piece of equipment. All services are carried in a carefully planned

system of wall and floor ducts, and of particular interest is a circulating system of clean distilled water at 50 psi. and 20-25° for cooling purposes.

Among the apparatus at present housed in the section are pieces of standard X-ray equipment for powder camera and orientation studies; Geiger-Müller counter sets at the moment engaged in high precision measurements of diffraction line intensities; and an Ehrenberg fine focus source giving a beam of  $5 \times 40 \mu$ .

## Projection Welding

### Advantages Over Spot Method

**P**ROJECTION welding is a method of resistance welding mild steel in which current flow and heating during welding are localised by the form of the parts being welded rather than by the electrodes in contact with the work. This is usually accomplished by a projection on one or both of the workpieces, and it is from this that the process derives its name. The projection may be formed by pressing, in the case of sheet metal, by forging or machining from solid pieces, or on the edge of strip by using special shears or punches.

The advantages of projection welding over spot welding include: more uniform results; ability to make several welds simultaneously; longer electrode life and lower electrode maintenance; improved finished appearance; and possibility of making welds which could not be made otherwise.

The majority of projection welding is carried out on steel with carbon content not exceeding 0.1 per cent, and if the carbon content is higher than this, particularly if it is associated with high percentages of manganese, and minor constituents such as nickel, chromium, molybdenum, etc., hard and brittle welds may cause difficulty. Generally, the thicker the material being welded, the higher the carbon content which can be tolerated.

A booklet on the subject, Ref. T30, has been published by the British Welding Research Association, 29 Park Crescent, London, W.1. price 3s. 6d. Prepared by a committee of the Association composed of resistance welding experts from the industry of Great Britain, this informative booklet covers all aspects of the method, and is the

first available in Britain to deal solely with this subject.

Recommendations are made to cover machines and electrodes, materials to be used, types of projections, and machine settings for various thicknesses of material. All are prepared from a series of extensive researches conducted by the BWRA during the past five or six years, and the booklet concludes with a section of suggested practices based on present industrial experience.

## Annatto for Dairy Products

THE British Standards Institution, in their series of standards covering dairy products, has issued BS. 2450, 'Annatto for dairy products.' This standard has been prepared with the object of reducing to a minimum the variations in the commercially available naturally occurring colouring matter known as 'annatto.'

While it has been possible to define in precise terms the colour of specified dilutions, it has not been possible to state with any degree of precision the colour imparted to cheese by the addition of a definite quantity of the colouring matter to milk. This differs appreciably according to the type of cheese, method of manufacture, storage, etc. The colour also varies from rind to centre and even over a small area such as 1 sq. in., so that an estimate of the colour can only be made by averaging a number of readings.

In conformity with modern practice the colour of standard dilutions of annatto has been expressed in C.I.E. units, but equivalents for two types of colorimeter commonly used in laboratory practice have also been given with the object of facilitating the measurement of the colour quality. Copies of this standard may be obtained from the British Standards Institution, price 2s.



## The Size of Particles

OPENING The Institute of Physics' four-day conference on the 'Physics of Particle Size Analysis' in the University of Nottingham last week, Sir Geoffrey Taylor, F.R.S., compared the difficulty of the underlying physical phenomena with processes such as the winnowing of chaff from wheat. The attendance of close on 300 people, including several from overseas, and the many original papers presented, reflect the considerable and growing importance of the subject in industry and in its applications in medicine. Recent developments in automatised methods of counting and sizing particles, including blood counts, were of special interest at the conference, and these discussions were supplemented by demonstrations of several new machines.

Other aspects of particle size analysis covered included the motion of particles in fluids and a comparison of sedimentation

methods for particle size analysis. Molecular phenomena encountered in the relative motion of fluid and fine particles, such as slip flow, surface diffusion and electroviscosity, also received consideration. Recent theoretical and experimental studies of the scattering and absorption of light by particles formed a valuable background in the study of photo-extinction and similar methods of size analysis. Consideration was also given to the practical issues of particle shape factors and visual counting and sizing with a microscope. The conference concluded with a general discussion, including comparison of methods of size analysis and the adhesion of dust particles.

The papers presented at the conference and the discussion on them are being published by the Institute as a supplement to its *British Journal of Applied Physics*. (Copies can be ordered through any bookseller or direct from The Institute of Physics, 47 Belgrave Square, London, S.W.1.)

## Clothes Storage

THE 'Sieber' patented hanger equipment is claimed to be particularly suitable for clothes storage in the chemical and allied industries. It comprises a unique method whereby the whole of an individual's clothing may be stored on a special hanger complete with basket. Hygienic requirements are fulfilled most satisfactorily. The equipment is solidly constructed of  $\frac{1}{4}$  in.

mild steel rod and is made to last a lifetime. Airing and drying of damp or rain-soaked garments is ensured, as clothing is spread out and not confined in a closed space without adequate ventilation. The manufacturers, James Sieber Equipment Co. Ltd., Africa House, Kingsway, London, W.C.2, offer a free planning service to those interested, provided they send a rough sketch of the area in which installation is intended, giving the dimensions.

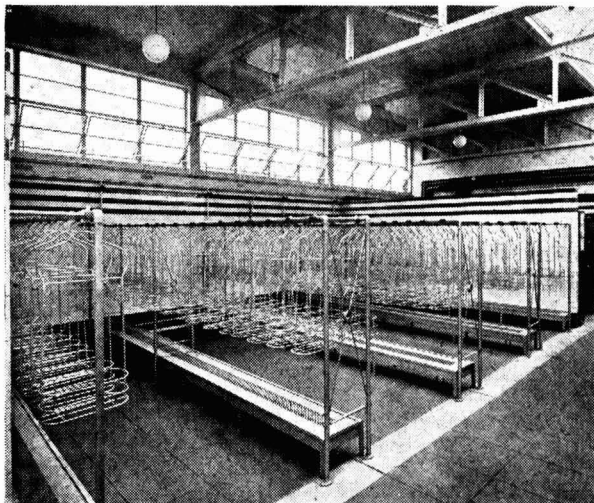

*A typical installation of Sieber patented hanger equipment*



# Water Pollution Research

## Progress in 1953 Reviewed in Board's Report

PLEASURE is expressed in the report of the Water Pollution Research Board for 1953\* that the central Water Pollution Research Laboratory at Stevenage is now being built. The report, which is signed by Professor D. M. Newitt as chairman, states that although there has been some delay, chiefly from shortages of labour and building materials, the work is well in hand and it is estimated by the Ministry of Works that the building should be ready for occupation during this year.

Reference is made to the work which was started in 1950 (at the request of the Ministry of Housing & National Government) to ascertain whether the methods of treating domestic water supplies ordinarily used at a water works would remove small quantities of radioactive isotopes if these were present in the water owing to enemy action or through having been discharged to rivers from industrial, medical or research establishments.

A laboratory was specially equipped for this work and several members of the staff received training and much valuable assistance at the Atomic Energy Research Establishment, Harwell, which also supplied the specialised equipment. A short description of the removal of radio-iodine during treatment of water was given in the report of the Director of Water Pollution Research for 1952 and in the present report there is a similar description of the removal of radio-strontium and other isotopes. The full results of this work, states the report, have been communicated to the Ministry of Housing & Local Government, who have issued a first circular to water undertakers and others concerned with the purity of water to assist them in planning civil defence.

### Thames Estuary Survey

The survey of the Thames Estuary, to which reference was made in previous reports, is still occupying a large proportion of the staff of the laboratory. The immediate object of the work now in hand is to provide information on which a considered policy for the future of the estuary can be based; thus, for example, decisions will have

to be made on the extent to which sewage and trade wastes should be purified before discharge to the estuary, on the amount by which the temperature of the estuary may be allowed to rise through use of water for cooling condensers at power stations, and on the extent to which fresh water should be taken from the upper reaches of the Thames for public supply.

### Biological Destruction of CN

Of the investigations made during the year on the treatment of industrial wastes, states the report, perhaps one of the most interesting is that on the destruction of cyanide by biological action. The work illustrates the diverse effects which substances from industrial processes may have on micro-organisms under different conditions. Thus, when cyanide is added to a sewage which has not previously contained it, it has an immediately adverse effect on biological processes of sewage treatment.

As was shown in the Report for 1952, however, the organisms responsible for the purification of the sewage will, in time, tolerate the presence of quite large concentrations of cyanide and will destroy it as it passes through a percolating filter. It has now been shown that they will do this even if the cyanide is not mixed with sewage but is the only source of carbon and possibly of nitrogen applied to a filter. The report adds: 'We propose to recommend that this work should be continued and extended in order to assess the possibility of using the process for the treatment on a large scale of certain industrial wastes containing cyanide.'

In the report of the Director of Water Pollution Research, which is combined with the Board's report, prominence is given to the investigation into the extent to which radioactive isotopes in water would be removed when the water was treated at a water works (referred to above).

The work reported refers to the removal of the  $\beta$ -active fission products, strontium-89 and 90, ruthenium-106, and cerium-144. Most of the work has been concerned with radio-strontium since this is one of the most

\* *Water Pollution Research*, 1952, HMSO, 2s. 6d. net.

dangerous of the possible contaminants of water supplies. The maximum permissible concentration of Sr-90 in drinking water, suggested by the International Commission on Radiological Protection<sup>2</sup>, is  $8 \times 10^{-7}$   $\mu\text{c}$ . per ml.—the lowest value recommended for any  $\beta$ -emitter.

In most of the experiments with radio-strontium a 'carrier-free' solution of Sr-90, as strontium nitrate, was used as the source of activity, though in a few of the earlier experiments a mixture of Sr-89 and Sr-90 was used.

#### Treatment with Coagulants

Experiments in beakers with both hard and soft natural waters, and with 'synthetic' tap water, states the report, showed that treatment with coagulants, in the quantities ordinarily used at a water works, did not remove more than 5 per cent of the initial activity due to strontium. This proportion could be increased by increasing the quantity of coagulant or by raising the pH value, but to remove any substantial proportion of the strontium required very large amounts of coagulant. Thus, treatment with ferric sulphate at a level of 100 ppm. Fe removed only 10 per cent of the initial radio-strontium at pH 7.0 and about 50 per cent at pH 11.0.

The effect was tried of softening water containing active strontium by adding calcium hydroxide followed by sodium carbonate. When these reagents were added in amounts approximately equivalent to the temporary and permanent hardness respectively, between 60 and 75 per cent of the active strontium was removed in all cases, this amount being largely independent of the relative proportions of temporary and permanent hardness and of the concentration of inactive strontium in the water. In some experiments this large proportion of the strontium was removed when the conditions were such that the solubility of strontium carbonate was not exceeded; it is supposed that this effect was due to the incorporation of strontium ions into the crystal lattice of the precipitated calcium carbonate.

In other experiments a 'synthetic' tap water with a total hardness of 300 ppm.  $\text{CaCO}_3$  was used; to this was added radio-strontium and 0.54 ppm. inactive strontium. When this water was treated with different quantities of lime, the proportion of radio-

strontium removed increased linearly with the proportion of hardness removed; the maximum removal of the radio-strontium when the water was completely softened was about 80 per cent.

A larger proportion of radio-strontium was removed when waters were softened by the base-exchange process using a sulphated coal, a synthetic aluminosilicate, and a synthetic resin. During the first cycle of softening more than 99 per cent of the radio-strontium was usually removed. In further cycles the proportion tended to decrease, but did not fall below about 97 per cent during the course of the experiments. These results were obtained with small columns of exchange materials. In similar work with a commercial domestic water softener operated under the conditions recommended by the makers, the proportion of radio-strontium appearing in the treated water was never more than 3.3 per cent of the initial value.

The effect of treating water containing radio-strontium in slow sand filters was also studied. At first almost complete removal was obtained, but the efficiency decreased rapidly until, after continuous use for 14 days, the activity in the treated and untreated water was approximately the same. When the filter was then treated with water containing no radio-strontium, the quantity of activity in the effluent fell rapidly and after three days was about one-tenth of its maximum value, after which it continued to decrease at a slow rate. It was shown that more than 99 per cent of the active strontium retained in the top layer of a slow sand filter was associated with the detritus and organic film at the surface and was readily separated from the sand during the normal process of washing.

#### Other Radio-isotopes

The behaviour of strontium was rather different from other radio-isotopes examined. With ruthenium-106, for example, activity appeared in the effluent within two hours of the first application of water to a slow sand filter; similarly, when filtration of uncontaminated water was resumed, the activity of the effluent fell rapidly. It was shown that the action of a slow sand filter in removing at least some radio-isotopes from water may be due in part to the adsorption of the isotopes on the sand grains as well as to the presence of micro-organisms.

For example, in experiments with cerium-144 approximately 60 per cent of the activity in the contaminated water was removed by a sterile filter. Under similar conditions a mature filter removed more than 97 per cent of the activity.

A considerable amount of work is being done to estimate the accuracy with which oxygen in solution can be determined under different conditions. There was some doubt as to whether in determining oxygen by the Winkler method—which is very rapid and convenient—sufficient oxygen entered a sample bottle during the addition of reagents to affect the result appreciably. This was checked, using a specially designed apparatus<sup>3</sup>, and it was found that the error was inappreciable. The Winkler method is also being checked by parallel gasometric determinations. It has been shown that when the Winkler method is used for determining dissolved oxygen in small samples of water an appreciable error may be introduced if starch is used as indicator; for a 10-ml. sample the error may be as high as 0.2 ppm. oxygen. This error can best be eliminated by using an amperometric method to indicate the end-point in the titration<sup>4</sup>.

#### Industrial Waste Waters

Dealing with industrial waste waters, the report recalls that it was shown last year that although the efficiency of treatment of sewage by biological filtration is at first reduced when very small concentrations of metallic cyanides are added to the sewage, this effect soon disappears. If the amounts of cyanide added are gradually increased, concentrations of the order of 100 ppm. are eventually tolerated without causing much deterioration in the quality of the effluent.

The report goes on to state that it has now been found that some metallic cyanides (potassium cyanide and the complex cyanides of zinc and cadmium) can be destroyed by biological action in a percolating filter without the addition of sewage or any other nutrient. For example, when a solution containing potassium cyanide equivalent to 100 ppm. HCN was treated, the concentration of HCN in the effluent did not exceed 1 ppm. With the complex cyanides of copper, nickel, and iron destruction is much less complete. It is possible that biological treatment of some types of waste water from electro-plating, and of the washing waters produced when steel is

hardened by dipping in molten sodium cyanide, might be both cheaper and more convenient than the chemical methods at present used. It is hoped to carry out tests with pilot plant.

#### Gas Works Liquor

At the sewage works at Stivichall, near Coventry, states the report, experiments were continued on the treatment of sewage to which was added spent liquor from the gas works at Hinckley, where hot gas is treated in electrostatic detarrers. Addition of about 2.5 per cent by volume of the spent liquor caused little deterioration in the quality of the sewage effluent. With ordinary spent liquor—such as that from the Leamington gas works with which experiments were carried out previously—so high a concentration would, of course, cause a very marked deterioration. The Hinckley liquor, however, does not contain retort-house liquor which is kept separate and is disposed of on land. When an appropriate amount of retort-house liquor was added to the spent liquor the effect of the mixture on sewage treatment was greater. Even so, the effect appears to be much less than was caused by the same proportion of mixed liquor from Leamington, where the hot gas is not treated by electrostatic precipitation.

The experiments on anaerobic fermentation of 'black liquor' from the kieren of cotton previously reported have been continued on a pilot plant scale. With a period of digestion of four days at 30° the biochemical oxygen demand of the liquor (which had previously been neutralised) was reduced by about two-thirds. The gas evolved contained nearly 70 per cent methane.

The laboratory is collaborating with the Ministry of Agriculture and Fisheries in a study of the effects of pollution on fish. A detailed survey is being made of conditions in an open channel carrying, with very little dilution, the effluent from the Colne Valley sewage works before it joins the River Colne. Perhaps the most striking observation made during this survey, so far as it has gone, is that the effluent channel contains at times very large numbers of fish. During the year over 9,000 coarse fish of four species were caught. The numbers vary considerably from time to time but the changes do not seem to be correlated with changes in the chemical condition of the effluent. One result of the survey has been

to emphasise how little is known about the natural movements and habits of fish in unpolluted rivers.

For comparison with the field observations, measurements of toxicity of substances likely to be present in sewage effluents are being made in the laboratory. One such substance is ammonia, the toxicity of which increases markedly with increase in pH value and with reduction in concentration of dissolved oxygen. Even when water is well oxygenated, a reduction in concentration—for example, from 100 per cent to 80 per cent of the saturation value—causes quite a large increase in the toxic effect of ammonia, and this may well be the general effect with most other poisons. Thus, in a river which contains directly toxic substances the precise level of oxygenation may be of great importance even though the level is much higher than that which, by itself, would cause asphyxiation.

#### REFERENCES

- <sup>1</sup> Downing, A. L., Wheatland, A. B., and Eden, G. E. *J. Instn. Wat. Engrs.*, 1953, 7, 555.
- <sup>2</sup> International Commission on Radiological Protection. *Nucleonics*, 1951, 8, [2], 70.
- <sup>3</sup> Staff of the W.P.R. Laboratory. *Wat. Sanit. Engr.*, 1953, 4, 48.
- <sup>4</sup> Knowles, G., and Lowden, G. F. *Analyst*, 1953, 78, 159.

## Floating Roofs

ASHMORE, Benson, Pease & Co., of Stockton-on-Tees, have just announced the conclusion of an agreement with General American Transportation Corp. of Chicago, to manufacture the patented Wiggins 'Hidek' and 'Lodek' floating roof structures for the petroleum and petrochemical industries.

In both the 'Hidek' and the 'Lodek' types the roof floats on the stored liquid and rises and falls in a free vertical movement during filling and emptying operations. An ingenious patented sealing device provides the seal between the roof and the tank shell.

The Wiggins 'Hidek' floating roof is designed for use in the storage of the more volatile products and eliminates the standing loss due to evaporation occurring in the vapour space between the stored liquid and the fixed roof of a storage tank.

The Wiggins 'Lodek' floating roof is designed for use in the storage of the less volatile corrosive crude oils and prevents the trapping of vapours between the liquid surface and the roof.

## Sulphuric Acid Output

### Lower in January, But Total Still High

ALTHOUGH sulphuric acid production in the UK during January was less than in December, 1953, it was higher than the average production for any month during the previous two years.

According to the latest (March) issue of the *Monthly Digest of Statistics*, published by the Central Statistical Office, the January figure was 174,800 tons (as 100 per cent acid), a decrease of 3,700 tons compared with the December figure. The previous highest monthly figure in 1953 and 1952 was 171,200 tons in November, 1953. Consumption of sulphuric acid (as 100 per cent acid) in January last was 177,000 tons, which was the same as for the previous month.

The total production of phosphatic fertilisers ( $P_2O_5$  content) in January was 34,600 tons, which was 2,300 tons more than in December, but 1,100 tons less than in January, 1953. Total consumption was the same as production—34,600 tons—which was 600 tons higher than the December figure.

Production of nitrogenous fertilisers in January was also higher, the total of 27,840 tons being 2,530 tons above the December figure and 710 tons more than the total for January, 1953. Disposals during January totalled 26,780 tons, compared with 19,050 tons in December. There was a decline in compound fertiliser production, the January figure of 172,000 tons being 9,200 tons below the December total, but 12,700 tons above that for January, 1953. Consumption of compound fertilisers in January last rose to 149,500 tons from 139,000 tons in December.

The latest available statistics for industrial alcohol are those relating to November, 1953. These show production at 480,000 gal., a decrease of 70,000 gal. compared with the previous month, and consumption at 570,000 gal., a decrease of 20,000 gal.

Carbon black production in January last dropped slightly in comparison with December, the total of 1,180 tons being 300 tons less than for the latter month. On the other hand, consumption rose from 1,070 tons in December to 1,120 tons in January.

The British Ceramic Society is officially co-operating in the European Ceramic Association Conference which is to be held in Italy between 27 September and 2 October.

# Comparative Studies in Gallium Chemistry

## Absorption Spectra of Gallium Complexes

THERE is no known mineral of which gallium is an essential constituent, but small quantities of this metal are being recovered from flue dusts in Britain and from the treatment of zinc residues in the United States. Though this metal has tended to be regarded as a by-product of germanium production, it possesses certain unique properties of potential value to industry, notably a melting point of only 29.7°.

Research on gallium is at present in progress on both sides of the Atlantic. A process for the recovery of gallium from flue dust was developed by the Chemical Research Laboratory, which has supplied samples on loan to research institutions, while the National Physical Laboratory is studying the unusual electrical properties of the metal. Some American work on gallium chemistry is reviewed in reports received by the Technical Information and Documents Unit of the DSIR.

An investigation of the relationship between pH and the extraction characteristics of acetate-buffered gallium (III) solutions is described by T. Moeller, A. J. Cohen and G. L. King, of the Illinois University, Urbana. This work formed part of a programme of comparative studies of the gallium-indium-thallium family.

### Quantitative Separation

The investigators have shown that under controlled conditions gallium can be quantitatively separated from large amounts of aluminium, using 5,7-dibromo-8-hydroxyquinoline in chloroform as the extracting medium. It had also been shown that solutions of gallium dibromoxinate in chloroform obey Beer's Law and that the 410 m $\mu$  peak is useful for the determination of between 0.0625 and 1.00 mg. of gallium per litre of solution. It would be useful if one could separate micro-amounts of gallium from large amounts of aluminium by direct extraction and determine the quantities by a spectrophotometric method. The extraction of gallium from sulphuric acid solutions buffered with sodium acetate has been investigated using dibromoxine in chloroform, in order to determine whether the gallium could be quantitatively

extracted and the optimum range of extraction. It was desirable to determine whether aluminium could be extracted in the optimum range under the same conditions.

### Extension of Earlier Work

Both 5,7-diiodo-8-hydroxyquinoline and 5-chloro-7-iodo-8-hydroxyquinoline being readily available, it was thought to be of interest to prepare the gallium derivatives of these reagents and to observe their absorption spectra in order to extend relationships established in earlier work. The experiments showed that gallium could be quantitatively extracted in micro-amounts from aqueous sulphate solutions buffered to pH values between 4.75 and 5.25 by the use of dibromoxine in chloroform. The quantity extracted is determined by comparison of the gallium dibromoxinate absorption peak at 410 m $\mu$  with the extinction of standards. It appears that aluminium is not extracted under the same conditions in this pH region.

Gallium diiodo- and chloroiodoxinates were prepared and appeared to give quantitative precipitation of gallium. The absorption spectra of these two gallium compounds were observed, as well as of the two reagents. The absorption spectra of these compounds were similar to those of other halogen derivatives studied previously. The peak wavelengths of these compounds were shifted to higher values, as was to be expected, with an increase in the molecular weight.

Oxine (8-hydroxyquinoline) is an excellent chelating agent and forms a number of more or less intensively coloured compounds with various metal ions. This property has led to its extensive use as an analytical reagent. In the formation of these chelated compounds the metal ion acts as a base while oxine, which is amphoteric in its properties, acts as an acid. In general, the number of oxine molecules attached to the metal ion is the same as the valence number of the metal ion in question. Oxine itself can exist in keto and enol forms.

Theoretically, therefore, it is possible for the metal ion to be bound through a co-ordinate bond to either the nitrogen or the oxygen, depending on whether the keto or



enol form of oxine is involved in the reaction. Most evidence seems to indicate that the enol form of oxine is predominant. It has been shown that the magnetic susceptibilities of oxinates of the divalent metals magnesium, zinc and cadmium are highly diamagnetic. This pronounced diamagnetic character indicates that the metal is bound through a co-ordinate to the nitrogen. Since this is true of divalent metals, there seems no reason to expect that trivalent metals, including gallium, would not behave in a similar manner.

Oxine has been used by a number of workers as a quantitative precipitating agent for gallium. One method for the quantitative determination of trace amounts of gallium is based on the fluorescence of a chloroform solution of gallium oxinate. It depends on the extraction of gallium oxinate from an aqueous phase at a pH of 2.6-3.0 with chloroform and a visual examination of the chloroform extract with a series of standards. Cohen and Moeller had previously investigated the absorption spectrum of gallium oxinate in chloroform solutions and found that three characteristic absorption peaks occurred in the range 300-400 m $\mu$ . They suggested the use of one of the peaks as an analytical method for the spectrophotometric determination of gallium.

#### Dihalogenated Oxinates

The purpose of the investigation here described was to extend Cohen's work on the preparation and study of the absorption spectra of various gallium dihalogenated oxinates. In addition, the extraction of some of these oxinates into chloroform solutions was investigated. Among the dehalogenated oxines studied were: dichloroxine (5,7-dichloro-8-hydroxyquinoline), dibromoxine (5,7-dibromo-8-hydroxyquinoline), diiodoxine (5,7-diiodo-8-hydroxyquinoline), and chloroiodoxine (5-chloro-7-iodo-8-hydroxyquinoline).

The work has shown that under proper conditions gallium may be quantitatively precipitated by any one of the dihalogenated derivatives. Each of these gallium complexes in chloroform solution possesses a characteristic absorption spectrum over the range 300-600 m $\mu$ , consisting of three broad absorption peaks, the most intense of which occurs in the vicinity of 400 m $\mu$ . In all cases this major peak has been found to obey Beer's law through the range of extinc-

tion values from 0 to 2.0 and apparently this peak is suitable for the spectrophotometric determination of gallium. The structure responsible for this major absorption peak is subject to photochemical decomposition when exposed to a direct light, but if precautions are taken to protect the solutions from light, reproducible results may be obtained for a period of at least a week.

Gallium Complex	Absorption Peak Major m $\mu$	Specific Extinction
Oxinate	392.5	92.8
Dichloroxinate	409	109
Dibromoxinate	410	125.7
Chloroiodoxinate	414	112
Diiodoxinate	416	125

It can be seen from the table above that, as the molecular weight of the particular gallium oxide derivative complex increases, the major absorption peak is shifted to longer wavelength values. With the exception of dibromoxinate, the specific extinction values also show a corresponding increase with increasing molecular weight. The value reported for dibromoxinate is rather higher than would normally be anticipated. In general, it seems that the substitution of halogens in the 5,7 positions on an oxine nucleus results in both hyperchrome and bathochrome effects; i.e., the extinction value is increased and the absorption band is shifted to lower frequencies.

On the whole, the extraction of gallium (III) in chloroform solutions of the various dehalogenated oxine derivatives has not proved particularly successful from an analytical point of view. Apparently the method is dependent on the previous history of the gallium solution to be extracted, and in most cases it is difficult, if not impossible, to obtain quantitative extraction of gallium (III), even though large excesses of the extracting reagent are employed.

The formation of the particular gallium oxine derivative complex in the aqueous phase and the subsequent extraction of this complex into chloroform is the most efficient extraction procedure so far employed. Analyses of the gallium content of the extract can readily be accomplished by absorption measurements, employing the major absorption peak for the particular complex in question. The extraction of gallium oxinate and gallium dichloroxinate using this procedure has been investigated, but the extent and number of interfering elements has yet to be determined.



# New Automatic Packaged Boiler

## A Landmark in Fuel Economy

THE Productivity Council reports covering investigations into various industries have been receiving a considerable amount of publicity over the past few years. One report which has perhaps never been given sufficient prominence is that concerning fuel conservation. Among the itemised list of recommendations was the following: 'There is need (in Britain) for the development of a type of self-contained automatically controlled oil-fired boiler of the American "packaged" pattern to supply the heat requirements of commercial buildings and small industrial plants.'

This need has now been met by G.W.B. Furnaces Ltd., of Dudley, Worcs., who are offering to the British market, for the first time, a completely self-contained packaged boiler suitable for either oil firing, gas firing, or a combination of both fuels.

### Horizontal Fire Tube Type

The boiler, marketed under the registered name of 'Powermaster,' is of the super-economic, horizontal fire tube type with three-pass gas travel, and is available in models giving steam outputs from 517-17,250 lb. per hr. The hot gases pass through the central cylindrical combustion tube to the rear, and then reverse through the lower bank of tubes, to the front; finally the gases then reverse again to the rear through the third set of tubes in two parallel banks on either side of the combustion tube, to the fume outlet.

The boiler complete with all ancillary equipment necessary for successful operation, including burner equipment, automatic controls, etc., is delivered to the customers' works, mounted on a strong steel base. No special settings or foundations are required and the unit, being already interpiped and interwired, only requires the fuel, water, electricity and steam connections to be made to render it capable of immediate operation.

The size of the packaged 'Powermaster,' when compared with a boiler of equivalent output, is far smaller (approximately one-half the space required) than a unit of conventional design. There is no need for a costly and unsightly stack since a forced draught fan is incorporated in every boiler,

resulting in the necessity for only a simple vent pipe for fume exhaust.

The focal point of any boiler is, of course, its heating system. In the 'Powermaster' oil-fired unit this consists of the 'Voriflow' air atomising oil burner which gives an excellent flame pattern, so important in multi-pass boilers, and consistently clean combustion over loads of from 20-100 per cent.

Among the advantages of the air atomising type of burner is the low oil pressure required, well under 20 psi., as compared with up to 300 psi. for a mechanical pressure atomising burner. The 'Voriflow' oil burner is capable of handling fuel oils from light oil with a viscosity of 31 sec. Redwood up to the heaviest oils of 3,500 sec. viscosity and over.

The 'Voriflow' gas burner is of the pre-mix design. The gas flows through the central nozzle from the gas plenum while, at the same time, combustion air from the blower enters the air plenum, automatically controlled by the motor operated damper. Primary pre-mixing air is directed through holes into the gas nozzle against venturi shaped baffles. The outer secondary air ring controls the quantity of secondary com-

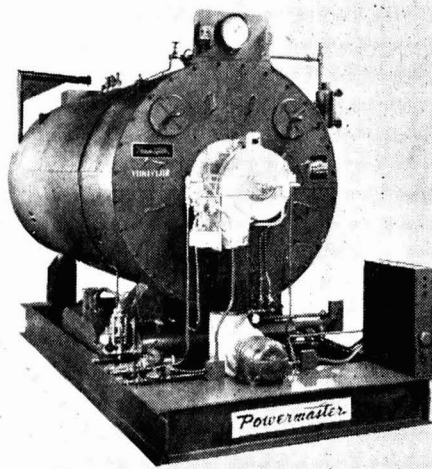

The 'Powermaster' oil-fired unit

bustion air admitted to the combustion chamber.

All necessary equipment for automatic and safe operation is fitted to every 'Power-master', including low water cut-off, draught fan interlock, excess pressure switch, excess temperature switch and automatic combustion control.

## Mechanical Handling

### Minister of Supply to Open 4th Exhibition

THE Minister of Supply, Mr. Duncan Sandys, M.P., will open the fourth Mechanical Handling Exhibition and Convention at Olympia, London, on 9 June. All space has been let for the exhibition, the world's largest and most comprehensive display of labour-aiding and ancillary equipment, which will remain open until 19 June.

The Convention to be held in conjunction with the exhibition consists of eleven papers by authorities in their differing fields on aspects of the handling of varying types and weights of materials, and an 'Any Questions?' session, under the chairmanship of Mr. W. J. Brown, of radio and TV fame, when six experts will attempt to solve any problem submitted to them from the audience.

The convention programme is now complete, as follows:—

10 June, 2.30 p.m.: 'Work Study and the Materials Handling Engineer,' by C. G. Chantrill. 11 June, 11 a.m.: 'Bulk Handling by Transporters,' by P. B. Tucker; 2.30 p.m.: 'Heavy Type Mobile Cranes,' by A. Hallsworth. 12 June, 11 a.m.: 'Bridging the Handling Gap,' by John Bright; 2.30 p.m.: Open Forum 'In Search of Better Handling.' 14 June, 11 a.m.: 'Belt Conveyors: application of all types to mechanical handling,' by T. R. Mackie; 2.30 p.m.: 'Notes on some Unusual Handling Problems,' by R. L. Sauvée. 15 June, 2.30 p.m.: 'Long Aerial Ropeways as applied to Mineral Development,' by Reginald H. Pearson. 16 June, 11 a.m.: 'Philosophy of Cargo Handling,' by Cdr. A. C. Hardy; 2.30 p.m.: 'Economics of Modern Materials Handling with Industrial Trucks,' by R. B. Lister. 17 June: Second European Mechanical Handling Conference (Private). 18 June, 11 a.m.: 'Safe Use of Fork Lift Trucks in Industry,' by A. C. Cooper; 2.30 p.m.: 'Process Mechanisation with the Aid of Spiral Conveyors,' by J. M. Beskine.

## Lack of Science Teachers

### FBI Committee Formed

THE serious effect on industry of the shortage of science teachers in schools was the subject of a conference of educationalists and industrialists organised by the FBI in January. A resolution passed at the conference recommended the Federation to set up a committee, representative of education, industry, and other employers of scientists, with the aim not only of increasing the supply of science teachers to the schools in the difficult years, 1955 to 1960, but of seeking a permanent solution.

Following this recommendation, the Federation has formed a Committee on the Shortage of Science Teachers with Dr. Percy Dunsheath, C.B.E. (chairman of the FBI Education Committee) as chairman, and the following members, each of whom will be serving in a personal capacity:

*Schools:* Miss M. J. Bishop, C.B.E. (Godolphin & Latymer School, Hammer-smith); Mr. W. R. Hecker (St. Dunstan's College, London); Mr. Ian Hepburn (Oundle School); Dr. W. G. Humphrey (The Leys School, Cambridge); Miss K. E. Parks (North London Collegiate School).

*Universities:* Professor J. W. Cook, F.R.S. (Regius Professor of Chemistry, The University, Glasgow); Mr. J. G. W. Davies, O.B.E. (secretary, Cambridge University Appointments Board); Professor E. Giffen (Professor of Engineering, Queen Mary College, University of London).

*Technical Colleges:* Dr. G. E. Watts (Principal, Brighton Technical College).

*Industry:* Mr. A. D. Bonham-Carter (Unilever Ltd.); Dr. W. S. Bristowe (Imperial Chemical Industries Ltd.); Mr. G. S. C. Lucas, C.B.E. (British Thomson-Houston Co. Ltd.); Mr. J. A. Oriel, C.B.E. (Shell Petroleum Co. Ltd.); Mr. L. A. Pilkington (Pilkington Bros., Ltd.); Mr. Madron Seligman (The A.P.V. Co. Ltd.); Mr. A. H. Wilson, F.R.S. (Courtaulds Ltd.).

*Government and Nationalised Industry:* Dr. B. K. Blount, (DSIR); Sir George Gater, G.C.M.G., K.C.B. (chairman of the Technical Personnel Committee, Ministry of Labour); Mr. M. Milne-Watson (chairman, North Thames Gas Board).

Sir Martin Roseveare and Mr. A. A. Part, M.B.E., of the Ministry of Education, have been invited to attend as observers.



**FLUORESCENCE ANALYSIS IN ULTRA-VIOLET LIGHT.** By J. A. Radley and Julius Grant. Fourth revised and enlarged edition. Chapman & Hall Ltd., London. 1954. Pp. 560. 52s. 6d.

Some 15 years have now elapsed since the appearance of the previous edition of this well-known volume on fluorescence analysis. During this period many new scientific papers have been published on this subject, although much of that described in German and other foreign journals has become available only comparatively slowly. It is a notable indication of the general interest maintained in fluorescence analysis that whereas the second edition dealt with about 1,500 references to the literature the number mentioned in the present edition is in the region of 3,500. A comparable increase has also taken place in the overall size of the book.

The general layout of the work is retained from previous editions. The theory and technique of fluorescence analysis form the subject of the first part of the book, and here the nature of light and the production and measurement of ultra-violet radiation are described. Details are given of various filters suitable for the absorption or transmission of ultra-violet radiation, and this section ends with an extensive account of the methods and technique employed in the application of fluorescence to scientific and technical problems.

The second and major section of the book deals with the uses of fluorescence analysis in various fields. Descriptions are given of its numerous applications in industries such as agriculture and those devoted to the commercial production of fuels, leather, paints and varnishes, paper and cellulose, rubber goods, textiles, and dyes. Problems of a more fundamental nature in bacteriology, botany, inorganic and organic chemistry, and medical and biological work may be solved with its aid. Among the chemical applications is the important use

of fluorescent indicators for volumetric analysis, which arises from the fact that the fluorescence of solutions of a number of substances changes in intensity or in colour with alterations in the *pH* of the solution. An extensive account is included of the applications of fluorescence analysis in the examination of drugs and food products. The latter account contains a valuable new section on the applications of fluorescence in the evaluation of certain of the vitamins and their related compounds. Other interesting applications are in the solution of problems concerned with museum work, such as distinguishing between spurious and genuine specimens, and with legal and criminological investigations. Forty-five photographs illustrating various fluorescence phenomena are included at the end of the volume.

The present edition is well produced and will no doubt receive as favourable reception from the scientific reader as did its predecessors.—G.S.E.

**TOXIC SOLVENTS.** By Ethel Browning, HM Medical Inspector of Factories. Edward Arnold & Company, London. 1953. Pp. viii + 168. 18s.

This book is not an easy one to review, as even the most diligent search has failed to suggest anything about it which the reviewer could criticise adversely. It deserves a place on every chemist's bookshelf, and its price is within the compass of most chemists' pockets.

'Toxic Solvents' gives the general properties of a considerable number of the most commonly used organic solvents, together with other relevant chemical matters, and these characteristics are set out with the clarity and consistency that make reference easy. Any attempt to create 'alarm and despondency' has been avoided, and the book could be placed in the hands of a quite junior assistant without his having any fear in connection with the work on which he

was engaged. There is a short, but adequate, medical glossary at the end and, in this case, one might remark that the definition given here of 'oedema' as a 'swelling' might cause some surprise to a non-medical man, as it did the reviewer, but there is no doubt that it is medically correct.

The short chapter on physiological effects of solvents is clear and readable, although Dr. Browning seems to have had some misgivings about its inclusion. There is no doubt, in the reviewer's mind, that a short and clear account, such as this is, will be of considerable value to anybody concerned with the safety of the individual. The book is well-printed and stoutly bound, so as to stand the handling which it should undoubtedly have.

In conclusion, one could do no better than quote the last paragraph of Mr. J. Davidson Pratt's foreword—'In short, this book is a valuable contribution towards ensuring the safety, health, and well-being of those who work in industries where solvents are made, handled or used.'—A. WEBSTER.

MANUAL FOR PLASTIC WELDING. Vol. 2. POLYETHYLENE. By G. Haim and J. A. Neumann. Crosby Lockwood & Son Ltd., London. 1954. Pp. 128. 30s.

This is the second volume in the Welding of Plastics series and is almost exclusively concerned with the hot-gas welding of polyethylene. Hot-gas welding is one of the most modern of crafts, having been developed during the last two decades. The procedures which have been devised are mainly applied commonsense, but commonsense based on an understanding of the medium in which it is applied. The book is intended to supply this understanding to the prospective welder and is to be used in conjunction with a practical training course. It is therefore doubly unfortunate that the introductory and theoretical section should be so badly written. The lines dealing with the chemical structure of polyethylene, although containing the relevant facts, present them in a fashion which is illuminating neither to the layman nor to the qualified chemist. It would have been preferable to begin with a description of the structure and properties of paraffin wax and discuss the differences and similarities with polyethylene having various degrees of polymerisation.

When describing the grading of polyethy-

lene the text is confused and misleading. As an example '... it is the custom to classify polyethylene by using a scale based on the fluidity of the material in the molten state ... Thus Grade 200, for example, is ten times more viscous than Grade 20.' In fact, the grade of a sample of 'Alkathene' (polyethylene manufactured in this country) is determined by weighing the amount of material in grams which flows through standard orifice under a fixed pressure at 190° in 10 minutes, the instrument used being a modification of the extrusion plastometer. It can be seen therefore that high grade numbers correspond to low values of viscosity. Again, while it is true that the viscosity of molten polyethylene is a better guide to its behaviour than the average molecular weight (at 200° the logarithm of the viscosity is approximately proportional to the square root of the number average molecular weight) nevertheless in the table of grades of polyethylene it is the molecular weight and not the melt viscosity which is quoted. Moreover, this table does not correspond in range or values with the table given in the manufacturer's booklet upon 'Alkathene.' Thus the average molecular weight of Grade 200 is quoted as 8,000 in the book and 14,000 in the booklet, the corresponding values for Grade 2 being 21,000 and 32,000.

On the other hand the chapters dealing with the practical aspect of the subject, which comprise the most important part of the book, are everywhere excellent. The commercially available forms of polyethylene are first described and then the tools and equipment. The layout for a workshop in which the welding of plastics is to be carried out is discussed and advice is given on the selection of personnel. In this connection there is a section giving a course of exercises which may be used to train prospective welders. The fabrication of chemical plant is described in considerable detail starting with the types of welds which can be employed and the methods of machining various forms of polyethylene. Plumbing with polyethylene tubing and the lining of tanks constructed from various types of material are covered. The text is made clear throughout by reference to diagrams, specifications, tables and photographs, and apart from its initial lapse the book can be recommended to all those concerned with the fabrication of articles, equipment or plant from polyethylene.—J.R.M.

## Resignations Sought

THE resignation of three of the four directors of Bowmans Chemicals Ltd., Widnes, is to be demanded at the annual meeting on 23 April by a committee of shareholders led by Mr. W. G. Black, of Heron Hill, Belvedere, Kent. The three directors concerned are Mr. E. G. Turner (chairman), Mr. S. H. W. Pert (managing director) and Mr. W. H. Bellamy (secretary and director).

In a circular letter sent to all shareholders, Mr. Black states that it is considered that the interests of the company demand that a new start be made in the direction of its affairs. After commenting that the accounts for the year ended 31 October, 1953, are satisfactory, Mr. Black goes on: 'But on closer examination you will find that the trading profit is due to three factors—the eating down of the company's stocks, general improvement in trade conditions and the great success of the process developed by Mr. David Marsh-Smith, on which the company is now largely dependent.'

### New Processing Method

Until Mr. Marsh-Smith was dismissed at an extraordinary general meeting of the company last year, he was technical director in charge of production at the company's works at Moss Bank, Widnes. He evolved a new method of processing lactic acids and lactates when (it is said) he found that the methods in use were not paying.

Among 'many points' with which it is proposed to deal at the annual meeting, Mr. Black instances the stage which negotiations have reached with the Inland Revenue over allegedly inaccurate returns in the past, the alleged execution of a mortgage on certain of the company's properties in favour of Branch Nominees Ltd. to secure £25,000, and a proposal to change the auditors.

---

### Norwegian Aluminium Plant

Norway's biggest aluminium plant—at Sunndalsöra, West Norway—which is estimated to have cost £12,500,000 and to be capable of producing 40,000 tons of aluminium a year, was officially opened recently. Two-thirds of the cost of the new plant has been financed by a USA loan, which will be repaid in the form of aluminium ingots. Full production will not be achieved until next year.

## Obituary

We regret to announce the death of MR. HAL E. HICKSON, B.Sc., D.I.C., M.I.Chem.E., aged 49, on 6 April while undergoing a minor operation. Mr. Hickson had many friends in the chemical industry and was well known among members of the Association of British Chemical Manufacturers, particularly in Group D. He was a Freeman of the City of London and was a Liveryman of the Dyers Company. Mr. Hickson was educated at Sedbergh and after graduation at the Imperial College, London, went to France where he practised for two years as a chemical engineer. After returning to England he was appointed technical manager of one of Courtauld Ltd.'s staple fibre factories in Wales. Shortly after the outbreak of the last war he became general manager of Hickson & Welch Ltd., of Castleford, and was later appointed to the board. By the end of the war his interests in timber preservation helped to develop this sphere of the company's activities. In this connection he made frequent visits to South Africa, East Africa and the United States of America and he represented the British Wood Preserving Association at the annual conference of the American Wood Preservers' Association. In recent years most of his energies were devoted to expanding the range of dyestuff intermediates and allied products manufactured by the company. At the time of his death he was joint managing director of Hickson & Welch (Holdings) Ltd., managing director of Hickson & Welch Ltd., and a director of Hickson's Timber Impregnation Co. (G.B.) Ltd., and of Hickson & Patel Ltd., Bombay.

MR. ROGER HEYWORTH, a director of Unilever Ltd., has died at the age of 52. Joining Lever Brothers Ltd. in 1923, he spent nine years on the Continent on their behalf. He was appointed chairman of Lever's associated companies in Shanghai in 1923 and joined the board of Unilever in 1947.

After being taken ill in a cafe a few hours previously, MR. FRED WILKINSON, chairman and managing director of J. B. Wilkinson (Chemicals) Ltd., died in Bradford Royal Infirmary on 9 April. Mr. Wilkinson, who was 80, was a member of the Bradford Dyers' & Colourists' Society and took an active part in local affairs.



---

# HOME

---

## Change of Address

Chemitrade Ltd. moved their offices from Piccadilly to 17 Stratton Street, London, W.1, on 12 April. The new telephone number is GROsvenor 3422.

## Another Price Increase

For the fifth time since 26 March, the Ministry of Materials has increased its selling prices for tungsten ores of standard 65 per cent grade and ordinary quality as follows: wolfram from 165s. to 175s. and scheelite from 160s. to 170s., both per ton unit delivered consumers' works. The latest increases took effect on 9 April.

## Australians Training in UK

The first six of a number of university graduates being recruited in Australia by the Anglo-Iranian Oil Co. Ltd. are now undergoing a period of training in the UK. Four chemists are studying refining processes at the company's major UK refineries (Llandarcy, Kent and Grangemouth) and two mechanical engineers are undergoing preliminary training at an engineering works at Bedford before going to a refinery for their oil training. At the end of their training the men will join the operating staff at one of Anglo-Iranian's refineries, either in the UK or overseas.

## Customs Duty on Zinc Dust

The Commissioners of Customs and Excise have been advised that all forms of zinc dust and powder (including 'blue powder' and other forms of dust and powder obtained directly from the distillation of zinc ores) are properly chargeable with customs duty on importation into the United Kingdom at the rate of 20 per cent *ad valorem* under Group VII (2) of the Schedule of Duties in Part 3 of the Customs and Excise Tariff. This ruling, in so far as it is not already applied in practice, will be brought into effect as from 1 May next. On and after that date, all importations of zinc dust or powder must be entered for customs purposes, and duty paid, in strict accordance with legal position as set out above. Any entries and home use warrants describing these goods as being liable at lower rates of duty will not be accepted.

## Aluminium Statistics

The Ministry of Supply states that the UK production of virgin aluminium during January this year amounted to 2,767 long tons; imports were 10,036 long tons and despatches to consumers totalled 16,481 long tons. Production of secondary aluminium for the same period totalled 8,975 long tons.

## Irish Salt Works Reopened

With the recent reopening of the Carrickfergus salt works after a 15 months' closure resulting from the failure of the brine supply from a local mine, 13,000 tons of salt will again be produced annually for industrial and domestic use. Imperial Chemical Industries Ltd., owners of the works, made new borings leading to the resumption of workings at Maidenmount mine, two miles from the town.

## Licence of Right

Under Section 35 of the Patents Act, 1949, the following patent was endorsed 'Licence of Right' on 26 March last: No. 674,450, S. A. Doresa, 'Process for the production of sulphur and compositions containing sulphur in a finely divided form'. Any person who claims that the patentee at the time of endorsement of the patent was precluded by a contract in which the claimant is interested from granting licences under the Patents Act may apply for cancellation of the endorsement on Patents Form No. 45, within two months after the date of the endorsement.

## To Market Vacuum Oils

Vacuum Oil Company Ltd, and Associated Coal & Wharf Companies Ltd. announce a joint arrangement whereby the A.C.W. Group undertakes the marketing on the south coast of Vacuum fuel oils which are now being produced at Vacuum Oil Company's refinery at Coryton, Essex. Vacuum Oil Company have been manufacturers and marketers in the United Kingdom of high quality lubricants since 1885, and with the completion of their Coryton refinery have recently entered the automotive and industrial fuel oil markets. The company have already inaugurated the policy of appointing established coal merchants as their fuel oil marketers.



---

# OVERSEAS

---

## Increasing Expenditure on Oil Plant

According to official American sources, the United States oil industry will spend a record \$2,860,000,000 (over £1,000,000,000) on new plant and equipment this year. This, the Petroleum Information Bureau says, is 4 per cent more than last year.

## Canadian Oil Reserves

Saskatchewan has proven oil reserves of nearly 1,000,000,000 barrels, according to a report made to the Legislature by the provincial Resources Minister, Mr. Brockelbank. He said there were 24 defined oil and natural gas fields, with 835 oil wells and 89 gas wells capable of production.

## Metal Production Up

Canadian production of primary silver, primary lead and primary and refined zinc were all higher last year than in 1952, the Dominion Bureau of Statistics reports. Output of silver amounted to 28,330,251 fine oz., or 12 per cent more than in 1952. Primary lead output totalled 195,791 tons, or 16 per cent more than in the preceding year, and output of primary zinc was up about 8 per cent to 400,041 tons.

## Customs Tariff on Polyethylene Resins

The Canadian Minister of Finance has referred to the Tariff Board as Reference No. 115 for inquiry and report, under the provisions of the Tariff Board Act, the customs tariff on polyethylene resins including, if necessary, polyethylene films, sheets, tubing, etc. Polyethylene resins are at present admitted duty free under the British Preferential and Most-Favoured-Nation tariffs under Tariff Item 901(a) 8, the item covering 'Other type' of synthetic resins without admixture, and under Tariff Item 902(o) the item covering 'Other type' of synthetic resins, compounded with other materials, etc. Polyethylene films, sheets, tubing, etc., are covered by Tariff Items 905(c) 1, 905(c) 2, and 906(e). For the purpose of receiving representations on Reference No. 115, a public hearing will be held at 541 Sussex Street, Ottawa, on 19 October next. Interested parties are requested to present at the public hearing, or file with the Secretary of the Board in advance of the date thereof, twelve copies of their representations.

## Austrian Production of Raw Magnesite

Last year, Austrian production of raw magnesite amounted to 804,800 tons, as compared with the 1952 production of 742,259 tons. The increase was due to greater mechanisation and better exploitation of deposits.

## Cement in Turkey

Following negotiations between the Turkish Cement Industry Co. and a delegation from Elazig, a £T5,000,000 company has been formed to establish a cement industry in Elazig.

## Fertilisers in the Philippines

The new Maria Cristina plants operated by the National Power Corporation at Ilagan City in the southern island of Mindanao will manufacture about 50,000 metric tons a year of commercial crystalline ammonium sulphate fertiliser of standard grade. The hydro-electric plant has a 25,000 kW. power unit and 90 per cent of its output is used by the fertiliser plant.

## Nuclear Engineering

Described as the first public meeting of its size devoted entirely to the peacetime uses of the atom, an International Nuclear Engineering Congress is to be held at the University of Michigan from 20-25 June. More than 100 papers and addresses will be given, twelve of which are from authors in Canada, England, Belgium, France, Norway, Italy, Spain and India. The technical programme has been planned by the Nuclear Energy Committee of the American Institute of Chemical Engineers.

## Australian Uranium Rush Begins

Australia's biggest uranium rush began on 1 April when the Government lifted its control over two big areas in the Northern Territory where rich deposits of this mineral are known to exist. Less than 12 hours after the lifting of the embargo, a number of claims had been pegged, and applications filed for leases at the Mines Department in Darwin. The areas opened are at Katherine and Coronation Hill, both south of Darwin. In the two areas, the Government has retained small holdings covering the sites of actual uranium discoveries.

---

## PERSONAL

---

DR. R. F. GOLDSTEIN, formerly development manager of chemical products for the British Oxygen Co. Ltd., has been appointed general manager of the chemicals division of the company.

MR. T. DALE JONES, manager of raw material supplies at Monsanto Chemicals Ltd., Ruabon, has been adopted by the Conservatives and Nat-Liberals as their candidate for Acton Ward, Wrexham, in the municipal elections next month.

MR. DENIS HAYS, buying manager of the production materials division at Fort Dunlop, has been appointed manager of replacement sales in the tyre division there. In addition to undertaking the duties carried out by the late Geoffrey Milburn as sales executive of the division, Mr. Hays will take over certain others under the direction of MR. R. C. HIAM, the division's general sales manager.

MR. A. B. HADLEY, manager of the Dunlop factories in Stoke-on-Trent, has been appointed works director of the Dunlop general rubber goods factory at Benoni, South Africa. He joined Dunlop at Manor Mills in 1919. For some time his main work was on process control and he was specialising in moulding problems when he went to Stoke as factory manager in 1945. Mr. Hadley's successor is MR. K. J. HICKIN, production manager of Dunlop's footwear division at Speke, Liverpool. Mr. Hickin joined Dunlop as a laboratory chemist when he was 17.

MR. THEODORE G. MONTAGUE, president of The Borden Company, has been elected a director of The International Nickel Company of Canada Ltd., MR. JOHN F. THOMPSON, chairman of the board of Inco, announced last week. Mr. Montague served as vice-president of The Borden Company, New York, from 1934 to 1937 and has been president since 1937. He is a director of The Borden Company Ltd. (Canada), chairman of Drake Bakeries Inc., a trustee of Bank of New York, trustee of Northwestern Mutual Life Insurance Co., and a director of the American Sugar Refining Company.

MR. T. REED, commercial works rail transport manager with Imperial Chemical Industries, Ltd., Billingham-on-Tees, has retired.

MR. J. M. F. COHEN has retired from the board of Manchester Oil Refinery (Holdings) Ltd. and MAJOR-GENERAL L. O. LYNE has been appointed to fill the vacancy.

MR. C. A. WILKES, manager of I.C.I. statistical department (Dyestuffs Division), Manchester, has been made a Fellow of the Chartered Institute of Secretaries.

MR. D. E. BUDGETT-MEAKIN has been appointed chairman and managing director of J. & E. Atkinson Ltd., in succession to MR. L. MACIVER, who has resigned from the board. The company, which manufactures perfumery and toilet soap, is a subsidiary of Unilever Ltd.

MR. HENRY M. BIBBY, great-grandson of the founder of the Liverpool seed crushing and soap manufacturing firm of J. Bibby & Sons Ltd., who has been a director since 1939, has been appointed vice-chairman of the firm in succession to MR. J. P. BIBBY, who had occupied that position since 1939 and will continue to serve on the board. MR. H. H. BIBBY and MR. HOWARD M. BIBBY have been appointed to the board.

Baker Platinum Ltd. have announced the resignation of MR. D. JAMES as managing director and the appointment of MR. S. R. BRYANT to that position. Baker Platinum Ltd. is a member of the Engelhard Group of Companies, one of the world's largest refiners and manufacturers of precious metals, with associate companies in America, Canada, South Africa, Australia and Europe. Mr. Bryant was born in Natal, South Africa, in 1905. He was educated in South Africa and trained as a mining engineer at Witwatersrand University and with the Central Mining Group. For the past 3½ years he has been manager of Harmony Gold Mine in the Orange Free State and immediately prior to resigning from the Central Mining Group was appointed as one of their consulting engineers in South Africa.

# Publications & Announcements

THE manufacture of high-grade salicylates has been the object of the Warrington Chemical & Drug Co. Ltd., Warrington, for more than 35 years, and they claim that the quality of the chemicals they produce ranks with the finest obtainable in any part of the world, since the strictest analytical control is exercised during manufacture. The plant is continually being modernised to meet present-day demands. Salicylates are used in medicine, as preservatives and in the dyeing industry, and as starting products for synthesis. Samples of the company's products may be obtained on application.

\* \* \*

LATEST number of the Instrument Engineer (April, 1954, Vol. 1, No. 5) published by George Kent Ltd., Luton, Beds., contains articles on 'Electrolytic Conductivity' by H. Wilson; 'Measurement of Natural Gas' by J. Tham; 'Uskmonth Power Station' by S. J. Clifton; and 'Flow Measurement by Differential Pressure—V' by John Lawrence Hodgson. Copies are obtainable, price 2s. 6d. each.

\* \* \*

THE difficulty of sealing effectively a driving shaft from a compressor, pump or similar piece of apparatus is well known. In many cases the leakage of obnoxious gases or liquids through a seal on the shaft can be a very serious matter, and although many types of packing and radial seals have been tried, the cost of maintenance is very high. For such applications the Electro Dynamic Construction Co. Ltd., St. Mary Cray, Kent, have introduced a coupling in which the driving member has no mechanical contact with the driven member, the power being transmitted by magnetic lines of force which pass through the hermetically sealed shroud separating the two members. The shroud is made of high electrical resistivity, non-corrosive, non-magnetic stainless steel or inconel, and is generally capable of withstanding pressures up to 50 psi., and temperatures of over 150°. A pamphlet dealing with these couplings is obtainable from the manufacturers.

\* \* \*

MOND Producer gas tars contain a high percentage of phenoloids, with a high fungicidal and bactericidal value, and with a mean molecular weight double that of coal

tar oils. These are the important constituents of 'Tectal' cordage preservatives, made by Melanoid Ltd., Dudley Port, Tipton, Staffs. Ropes treated with 'Tectal' show no 'tendering,' and tests indicate that the preservative retains its properties on long exposure. 'Tectal' can be employed by itself, or incorporated with copper naphthenate. A pamphlet describing these preservatives may be obtained from the manufacturers.

\* \* \*

STEEL tubes are regarded as having particular advantages in materials handling equipment: they are light, rigid and strong, and possess great torsional resistance. Their smooth surfaces make them easy to handle and reduce accidents. A booklet published by Tubewrights Ltd., Egginton House, 25 Buckingham Gate, London, S.W.1 (a subsidiary of Stewarts & Lloyds) shows by means of clear illustrations some examples of tubular equipment used in materials handling, including the chemical industry. The company offers to design tubular steel materials handling equipment to meet every kind of special requirement.

\* \* \*

GEMEC Ltd., who are UK distributors for Carbide & Carbon Chemicals Co., New York, have copies of the latter's booklet 'Alcohols' available. This describes the properties and applications of 17 alcohols ranging in carbon content from one to 17 carbon atoms. The lower alcohols are well-known as anti-freeze bases, solvents, anti-septics and germicides. Alcohols containing from four to eight carbons find uses in varnishes, lacquers and other protective coatings, and as extractants in various processes. The higher alcohols, particularly 2-ethylhexanol, are widely used as intermediates for plasticisers, wetting agents, and as anti-foam agents.

\* \* \*

ORGANISATION of F. W. Potter & Soar Ltd. has been developed over more than 125 years, and woven wire is produced and stocked by them in large quantities. A recently-published brochure gives details of the different metals, mesh sizes, gauges and roll widths in which the wire is available. A number of made-up sieves and strainers are also described.

A WIDE range of containers for factory and farm use is announced by Dunlop Rubber Co. Ltd., St. James' Street, London, S.W.1, in a new flexible compound of rubber resin which enables them to keep their shape under the roughest treatment. It has already been made up in a standard thickness of  $\frac{1}{8}$  in. into buckets for farms and factories, bogie linings for textile factories, square bins for cloth cuttings and other waste material, trays for rack-on-rack storage of small metal parts, and round bins to hold liquids or waste. 'Fortiflex,' as it has been named, is resistant to vegetable fats and low-concentration acids and alkalis. It is light in weight, noiseless, and easily washed, and it reduces both replacement costs and the risk of injury to workers.

\* \* \*

IT has been announced by Borax & Chemical Ltd., 229 High Holborn, London, W.C.1, that they have been appointed sole selling agents for Bikita Minerals (Private) Ltd. in Europe and the sterling area. The Bikita company, under management of Selection Trust Ltd., owns and operates an important deposit of lithium and beryllium situated near Fort Victoria in Southern Rhodesia. Initial production and bulk shipments of lepidolite (lithium ore) are now taking place. Output is to be increased in the next few months. Apart from use as raw material for production of lithium chemicals, lepidolite and associated lithium minerals are used widely in the manufacture of special glasses, vitreous enamels and ceramics, in which industries Borax & Chemicals Ltd. already have a long established connection with their range of 'Three Elephant' brand boron products. The demand for lithium products has been increasing sharply and interest is growing in lepidolite as a cheap source of lithia in glass and enamels.

\* \* \*

LEAFLET A105a, issued by R. H. Windsor Ltd., Leatherhead Road, South Chessington, Surrey, replaces Leaflet A105 and describes the improved S.H.4 fully automatic injection moulding machine, with the new valve block assembly. Self-contained and hydraulically operated, the machine is claimed to be easy to handle and capable of maintaining high rates of production. It is provided with fully or semi-automatic cycle control as required. The valves in this new system are grouped upon a single mounting block, which has holes in it to form interconnec-

tions. This grouping brings the directional controls and pressure adjusters into a single cabinet. The remaining pipe-work is thus greatly simplified and the sensitivity of the machine to the operating controls is improved.

\* \* \*

UNDER the title of 'Non-Ferrous Heavy Metal Fabrication in the USA,' the Organisation for European Economic Co-operation has published a report prepared by a Technical Assistance Mission, consisting of 22 specialists from nine European countries, which visited the US in the autumn of 1951. The object of the Mission was to study American techniques of fabricating sheet, strip, rods, sections, tubes and wire of heavy non-ferrous metals and alloys. Visits were paid to a number of plants and the Mission attended the first World Metallurgical Congress in Detroit. The report, consisting of more than 250 pages, is divided into eleven chapters written by specialised members and approved by the whole Mission. Copies are obtainable from HMSO, P.O. Box 569, London, S.E.1.

\* \* \*

THE 'Segas' catalytic oil gas process originated in the laboratories of the former South Metropolitan Gas Co. and after nationalisation of the gas industry the work was continued by the South Eastern Gas Board. In due course an agreement was made whereby The Power-Gas Corporation Ltd., Stockton-on-Tees, became the sole licensee for the commercial development of the process, which is designed to produce from oil a gas with calorific value, specific gravity and combustion characteristics similar to those of town gas. The process is fully described and illustrated in a technical publication just issued by The Power-Gas Corporation, from whom copies are obtainable on request.

\* \* \*

PREPARED by the Central Office of Information as part of the UK overseas information services, *Commonwealth Survey* is an authoritative document published fortnightly by HM Stationery Office. It is designed for use by industrialists, merchants, libraries, lecturers and others with a specialist interest in the Commonwealth. A wide variety of subject matter is covered by each issue. The annual subscription is 25s., including postage. Applications should be made to HMSO, P.O. Box 569, London, S.E.1, enclosing remittance.

## Law & Company News

### Commercial Intelligence

The following are taken from the printed reports, but we cannot be responsible for errors that may occur.

#### Satisfaction

OXY-FERROLENE LTD., London, W., manufacturers of oxygen, chemicals, etc. Satisfaction, 6 March, of mortgage registered 20 October, 1943.

---

### New Registrations

#### Sipon Products Ltd.

Private company. (531,607.) Capital £10,000. Chemical manufacturers, chemists, druggists, etc. First directors to be appointed by subscribers. Reg. office: 30 Cornhill, London, E.C.3.

#### Harliculture Ltd.

Private company. (530,659). Capital, £1,000. Manufacturing, agricultural and horticultural chemists, etc. Directors: Josephine R. F. Bonnin and Florence D. Law. Reg. office: Stafford House, Priory Avenue, Harlow, Essex.

#### Pectin, Ltd.

Private company. (531,483.) Capital £100. Importers, exporters and manufacturers of and dealers in goods and merchandise of all kinds, including chemicals, solvents, plastics, essential oils, etc. First directors not named. Solicitors: Amphlett & Co., 6 Wine Office Court, London, E.C.4.

---

### Company News

#### The Distillers Co. Ltd.

The directors of The Distillers Co. Ltd. announce that they have declared a dividend on the preference capital of the company for the six months ended 31 March, 1954, at the rate of 3 per cent less income tax, payable on 15 May to stockholders on the register at 8 April.

#### Manchester Old Refinery (Holdings), Ltd.

For the year 1953 an ordinary dividend of 6 per cent, less tax, is being paid by Manchester Oil Refinery (Holdings) Ltd., formerly Manchester Oil Refinery Ltd. This compares with 10 per cent for 1952 and

20 per cent for 1951. Group net profit is £16,000, after tax of £35,000, against £5,730 for 1952 after tax of £26,674. The amount carried forward is £43,000, after £5,000 capitalisation of a subsidiary's profits. In March, 1953, the production side of the business was transferred to a wholly-owned subsidiary, Barton Refinery, which company's name was subsequently changed to Manchester Oil Refinery Ltd.

#### Gas Purification & Chemical Co. Ltd.

Net trading profit of £16,484 for the past year is reported by the Gas Purification & Chemical Co., Ltd. This compares with £26,176 for the previous year. The net profit after tax is £6,000 (£6,930). The directors state that turnover was lower than the previous year and prices of spent oxide continued to fall, but present conditions are more favourable and the current year's trading so far is satisfactory.

#### British Industrial Plastics Ltd.

Speaking at the recent annual meeting of British Industrial Plastics Ltd., the chairman, Mr. Kenneth M. Chance, said the company's No. 2 factory had been equipped with plant designed to convert into saleable resins and moulding powders some of the products of the fractional distillation of petroleum and now that the great factories installed for that purpose in Great Britain were coming into active commission, work on methods of conversion of those products would be the main objective of the company's development department. A process had already been proved on the industrial scale for the manufacture of polystyrene, but as ample supplies were available from other sources in this country the directors considered it preferable to concentrate upon the production of resins for use with glass fibres, for which purpose the company had the rights to use the patents of the American Cyanamid Co. in this country. A building was in course of erection at Oldbury which would be equipped with a complete pilot plant for development work upon the application of those resins. Dealing with the accounts, Mr. Chance said the available profit for the group was £111,000, from which the directors recommended a final dividend of 12½ per cent, making 20 per cent, less tax, for the year.

## Next Week's Events

TUESDAY 20 APRIL

### Society of Chemical Industry

London: Royal College of Science, Imperial Institute Road, South Kensington, S.W.7, 2.30 p.m. Agriculture Group meeting. Symposium on 'The Large-scale Clearing of Forests.'

### Institute of Metals

London: Holborn Restaurant, Kingsway, W.C.1, 3 p.m. Hodsall Memorial Lecture by Dr. William Blum: 'The Future of Electroplating.'

WEDNESDAY 21 APRIL

### Society of Chemical Industry

Newcastle: King's College (Chemistry Lecture Theatre), 6.30 p.m. Newcastle Section annual general meeting. Chairman's address by A. W. Kay.

### Royal Statistical Society

Newcastle: Old Staff Room, Armstrong Buildings, King's College, 6.45 p.m. North East Group annual general meeting, followed by paper by K. R. Williams: 'Sensory Tests in Industrial Research.'

THURSDAY 22 APRIL

### Royal Institute of Chemistry

Luton: Town Hall, 8 p.m. Joint meeting with Luton Scientific Association. Tudor S. G. Jones: 'A Modern View of Chromatography.'

### Chemical Society

Belfast: Queen's University (Chemistry Lecture Theatre), 7.45 p.m. Meeting for the reading of original papers.

FRIDAY 23 APRIL

### Chemical Society

Liverpool: The University (Chemical Lecture Theatre), 5 p.m. Joint meeting with RIC, SCI, British Association of Chemists and University Chemical Society. Dr. R. H. F. Manske: 'The Story of the *iso*-Quinoline Alkaloids.'

### Society of Chemical Industry

Glasgow: Royal Technical College, 7 p.m. Glasgow Section annual general meeting, followed by paper by F. Rumford on 'Fluidised Solids.'

SATURDAY 24 APRIL

### Institution of Chemical Engineers

London: University College (Chemical Engineering Department), Gower Street, W.1, 10 a.m. Graduates' and Students' Section annual general meeting. Annual dinner and dance, Chez Auguste, Frith Street, 7 p.m.

## Market Reports

LONDON.—The demand for industrial chemicals continues to be good for most of the home outlets, but with the approach of the seasonal holiday there is some curtailment in delivery. The flow of export inquiries remains fairly consistent in volume. Apart from further increases in the basis prices of white, red lead and litharge, there have been no outstanding price changes to record, and in most sections of the market the undertone is steady. The revised basis prices as from 12 April were dry red lead £126 5s, per ton, litharge £128 5s, per ton, and dry white lead £132 5s, per ton. The coal tar products market is without new features, and for the most part items offered are being readily absorbed.

MANCHESTER.—Values of heavy chemicals on the Manchester market during the past week have been on a generally steady to firm basis, with little actual changes of any consequence to record. Deliveries under contract to the textile and allied industries and other leading consumers have been on a fair scale, although there have been unmistakable signs of a slackening-off in anticipation of the holiday break. Fresh bookings during the week have been on a moderate scale. In the fertiliser section there has been a fairly steady movement of supply of compounds, sulphate of ammonia and superphosphates. A ready outlet for most of the tar products continues to be reported.

GLASGOW.—As opposed to the previous week which was rather quiet, trade during the past week was somewhat brisker, although the increased prices which came into force due to the recent wages awards have been somewhat unsettling. Copper and zinc prices have shown a slight advance, but prices for lead products have remained unaltered.

### At the Utrecht Fair

Exhibitors at the recent Utrecht Fair included Langley Alloys Ltd., Langley, Slough, Bucks, who displayed a wide range of their products. Apart from the standard production of castings, stampings and rolled and forged sections, the company produces a range of chemical valves in various materials, such as nickel alloys, stainless steels and aluminium bronze. These were fully represented, the various types shown including 'Y' valve, gate, globe, needle, check and strainer valves.



# KEEBUSH

Keebush is an acid-resisting constructional material used for the construction of tanks, pumps, pipes, valves, fans, etc. It is completely inert to most commercial acids; is unaffected by temperatures up to 130°C; possesses a relatively high mechanical strength, and is unaffected by thermal shock. It is being used in most industries where acids are also being used. Write for particulars to—

## KESTNER'S

5 Grosvenor Gardens, London, S.W.1

## JOHN KILNER & SONS (1927) LTD

ESTABLISHED 1867

Calder Vale Glass Works, Wakefield, Yorks.

PHONE: WAKEFIELD 2042 GRAMS: GLASS, WAKEFIELD

SPECIALISTS IN

**Carboys · Demijohns  
Winchesters**



**LEIGH  
& SONS  
METAL  
WORKS**

Orlando LTD.  
St., BOLTON

**CARBOY HAMPERS**

CARBOYS: PACKED CARBOYS  
CARBOY TILTERS AND BARROWS.  
SAFETY CRATES TOP PROTECTORS

## IRONAC METAL FOR RESISTING ACIDS

VALVES, TAPS AND CASTINGS  
FOR CORROSIVES  
**HAUGHTON'S METALLIC  
CO., LTD.**

30, St. Mary-at-Hill, London, E.C.3.

## MULTITUBULAR DRIERS ROLLER FILM DRIERS FLAKERS AND COOLERS

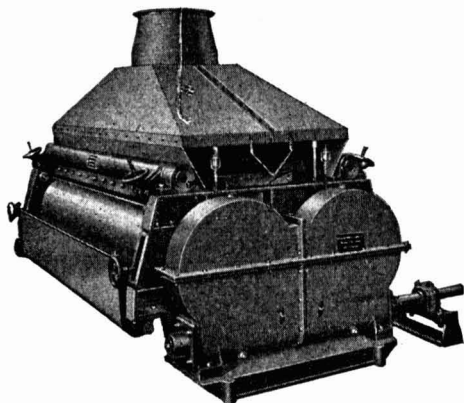

We offer accumulated experience of 50 years' specialization.

OUR WORKS, the largest in the United Kingdom devoted especially to DRYING MACHINERY, are laid out and equipped with the latest plant for this particular purpose.

MANY STANDARD SIZES including LABORATORY MODELS.

*We have test plants always available*

## RICHARD SIMON & SONS, LTD.

PHENIX WORKS, BASFORD, NOTTINGHAM

---



---

# CLASSIFIED ADVERTISEMENTS

---



---

## EDUCATIONAL

**THE INSTITUTION OF CHEMICAL  
ENGINEERS  
30TH (1954) ASSOCIATE MEMBERSHIP  
EXAMINATION**

APPLICATION forms (returnable 1st June, 1954) and particulars of the 30th Associate Membership Examination, may be obtained from the Secretary, **INSTITUTION OF CHEMICAL ENGINEERS, 56, VICTORIA STREET, LONDON, S.W.1.**

---

## SITUATIONS VACANT

*The engagement of persons answering these advertisements must be made through a Local Office of the Ministry of Labour or a Scheduled Employment Agency if the applicant is a man aged 18-64 inclusive, or a woman aged 18-59 inclusive, unless he or she, or the employment, is excepted from the provisions of the Notifications of Vacancies Order, 1952.*

### HER MAJESTY'S COLONIAL RESEARCH SERVICE NIGERIA.

A VACANCY exists for a **SCIENTIFIC OFFICER (CHEMIST)** for Sokoto Malaria Control Pilot Project (CDE 87/14/03).

**QUALIFICATIONS.**—Candidates, male, must possess at least a 2nd Class Honours Degree.

**DUTIES.**—The project will be conducted in Northern Nigeria, the experiment being designed to test house applications of modern insecticides for control of mosquitoes. The chemist will be required to follow up spraying operation by chemical studies of the persistence of insecticidal deposits and reasons for their disappearance.

**TERMS OF APPOINTMENT.**—Temporary for one tour of 12 to 24 months in first instance, with basic salary according to experience in the scale £400-£650 per annum, plus U.K. pay addition of between £40 and £57 10s. and Overseas Research allowance of between £250-£350 per annum. Gratuity at rate of 15 per cent of total basic salary drawn payable on satisfactory termination of appointment. **OUTFIT ALLOWANCE.** £60. Free passages for officer, wife and all children under 13; 1 ave o 7 days for each completed month of resident s vice; quarters, if available, at rental of 10 per cent of basic salary; income tax at local rates.

Apply in writing to the **DIRECTOR OF RECRUITMENT, COLONIAL OFFICE, GREAT SMITH STREET, LONDON, S.W.1**, giving briefly, age, qualifications and experience. Mention the reference number CDE.87/14/03

**CHEMICAL ENGINEER.** A nationally known food manufacturing company seeks for a plant in Scotland a young man of technical and administrative ability, for an appointment of progressive production responsibility. Applications are invited from graduates (Chemical Engineering, Applied Chemistry or Chemistry) with 2-5 years' industrial manufacturing experience, who seek the opportunity by hard and effective work to make a worthwhile career on the manufacturing side of a progressive expanding company. Please reply, giving age, education and experience, to **BOX No. C.A. 3305, THE CHEMICAL AGE, 154, FLEET STREET, LONDON, E.C.4.**

## SITUATIONS VACANT

**ASSISTANT CHEMIST** (Inter B.Sc.), for interesting work on **GAS and SMOKE FILTRATION** in Laboratory in Central London. Analytical training and experience useful. Excellent salary for suitable applicant. Apply **BOX No. C.A. 3304, THE CHEMICAL AGE, 154, FLEET STREET, LONDON, E.C.4.**

**CHEMIST/TECHNOLOGIST**, with experience of Rubber Latices, Dispersions, Adhesives and allied products, is required by a public company in the Manchester area manufacturing for the rubber and associated industries. This is a completely new appointment, and the successful candidate, who should be of approximate B.Sc. standard, will be required for technical development work in our laboratories and complete liaison with customers. The position provides excellent prospects for someone possessing the necessary experience and personality. Good commencing salary and participation in Staff Bonus and Pension Schemes. Full details should be given of age, education, experience and salary required. Our present staff is aware of vacancy. **BOX No. C.A. 3306, THE CHEMICAL AGE, 154, FLEET STREET, LONDON, E.C.4.**

**IMPERIAL CHEMICAL INDUSTRIES, LIMITED**, requires a **CHEMIST** for the **TECHNICAL SERVICE DEPARTMENT** of its **GENERAL CHEMICALS DIVISION** in Liverpool. Applicants should be aged 25-30, and possess a Degree in Chemistry or equivalent qualification. The work is primarily concerned with organic products, and a knowledge of Chemical Engineering would be an advantage. The starting salary would be in the range of £600 to £900, depending on age, qualifications and previous experience. Applications should be made in writing to the **STAFF MANAGER, IMPERIAL CHEMICAL INDUSTRIES, LIMITED, GENERAL CHEMICALS DIVISION, CUNARD BUILDING, LIVERPOOL 3.**

**LARGE CHEMICALS WORKS in HOME COUNTIES** require young, active men who have completed their National Service commitments, to train for shift supervisory duties in the factory. Minimum standard required is General Certificate or equivalent in Chemistry, Mathematics and English. Salary according to age, qualifications and experience. Canteen facilities. Pension Scheme. Apply **BOX No. C.A. 3301, THE CHEMICAL AGE, 154, FLEET STREET, LONDON, E.C.4.**

**WANTED** by old-established Company with varied interests, **REPRESENTATIVE** for **CHEMICAL SECTION**. State age and experience. All in strictest confidence. **WRITE 0647, WM. PORTEOUS & CO., GLASGOW.**

---

## FOR SALE

A **2-TON MOBILE CRANE** of the very latest high-speed type now available for demonstration. It costs only £1,450 and travels at 12 m.p.h. Diesel fuel consumption cost barely 9d. per hour. With a 1½ cubic yard hydraulic grab it is the simplest, cheapest and most efficient way of handling loose materials in bulk. The ideal machine for loading and unloading railway trucks and road vehicles.

**WILLIAM R. SELWOOD, LTD., CHANDLER'S FORD, HANTS.**  
Phone 2275.

## FOR SALE

**ALLEY & MAC-LELLAN A.C.I. VACUUM PUMP**, for maintaining 24 in. vacuum. Vertical type, water cooled. Displacement, 150 cu. ft. air per minute. With filter, unloader and pressure gauge reading 80 p.s.i. **F. J. EDWARDS, LTD., 359, EUSTON ROAD, LONDON, N.W.1.** (Euston 4681.)

**CHARCOAL, ANIMAL AND VEGETABLE** horticultural, burning, filtering, disinfecting, medicinal, insulating; also lumps ground and granulated; established 1830; contractors to H.M. Government.—**THOS. HILL-JONES, LTD., "INVICTA" WORKS, BOW COMMON LANE, LONDON, E. TELEGRAMS: "HILL-JONES, BOCHURCH LONDON." TELEPHONE 3285 EAST.**

**ECONOMIC BOILERS**, 10 ft. Danks, 12,000 lb. evap. 250 lb. pressure. Two Brand New 14 ft. by 8 ft. by 150 lb. w.p. **IMMEDIATE DELIVERY.** 400 other Boilers in stock.

Whesove Riveted Steel **MIXING TANK**, 13 ft. diam. by 15 ft. deep, 9-16 in. plate, cone base.

**TWO 35 ft. long by 9 ft. diam. Lead-lined TANKS.**  
**ONE Stainless CONICAL HOPPER**, 7 ft. 3 in. diam., overall depth 7 ft. 6 in.

**SIX Stainless Steel JACKETED PANS**, 60 galls.  
**TWO Broadbelt WATER-DRIVEN CENTRIFUGES**, 30 in. diam., 12 in. deep, 1,150 r.p.m.

**SIX Aluminium CONDENSERS**, 14 ft. long by 2 ft. 6 in. diam. 386 Tubes,  $\frac{3}{4}$  in. o.d.

**FORTY Riveted RECEIVERS**, 8 ft. 6 in. long, 5 ft. 6 in. diam., 75 lb. w.p. Numerous other sizes.

**Solid Drawn STEEL PIPES**, 6 in., 8 in., 10 in., 12 in., 14 in., thousands of feet in stock, plain and flanged.

**CAST-IRON PIPES**, 400 yds. 8 in. **NEW.** Also most other sizes, up to 24 in. bore.

**VALVES** in Stainless, Gunmetal, Enamel Lined. Free Catalogue. "Watkins Machinery Record," available.

**FRED WATKINS (BOILERS), LTD., COLEFORD, GLOS.**

**FOR SALE**—8 tons of **AMMONIUM BICARBONATE**, packed in 2-cwt. free drums. Samples available on request. Apply **BOX No. C.A. 3299, THE CHEMICAL AGE, 154, FLEET STREET, LONDON, E.C.4.**

**JOURNALS AND PERIODICALS** in sets and back files, bought and sold. American, British, Foreign—Chemical Scientific, Technical. Large stock. Catalogues issued. **J. S. CANNER, INC., BOSTON, 19, MASS., U.S.A.**

**MORTON, SON AND WARD, LIMITED**

office  
**JACKETED PANS**

**100g**, 150g. and 200g. **NEW** in mild steel for 100 lb. w.p. with or without mixing gear.

Others made to requirements in s.s. or m.s. with or without mixing gear.

**500g. jacketed AUTOCLAVE** with detachable cover. 150 lb. in jacket.

**MIXERS**

**'MORWARD' 'U' TROUGH MIXERS** and drying units in sizes up to 3 tons. Horizontal or vertical **MIXERS** jacketed or unjacketed made to requirements. Several in stock.

**50g., 75g. and 100g. heavy duty MIXERS** by **FALLOWS** and **BATES**. Agitators driven through bevel gears from f. and l. pulley.

**3 cwt. trough MIXERS** by **CHALMERS** and **GARDNER** s.s. lined troughs.

**200g. c.i. jacketed mixing vessel** with nickel chrome impeller type agitator driven through bevel gears from f. and l. pulley.

**PUMPS**

A large selection of **MONO** and other **PUMPS** in stock, 2 in. to 5 in. new and second hand.

**ONE 3 ft. 6 in. PEBBLE MILL** by **LINATEB** in excellent condition, motorised with inching switch.

**ENQUIRIES INVITED.**

**MORTON, SON AND WARD, LIMITED,**

**WALK MILL,**

**DOBCROSS, NR. OLDHAM,**

**LANCS.**

Phone: Saddleworth 437.

## FOR SALE

**C. BARBER, LTD.**

**C.I. FILTER PRESS**, 32 in. square plate and frame type by **MANLOVE ALLIOTT** with hydraulic closing gear. 40 chambers giving cake capacity of 40.3 cu. ft. New and unused.

**500-gal. Over-driven M.S. MIXING VESSEL**. M.S. pressure filter, 4 ft. 3 in. diam. by 5 ft. 3 in. overall height.

**C.I. FILTER PRESS**, 25 $\frac{1}{2}$  in. square, by **MANLOVE ALLIOTT**, plate and frame type, 13 chambers, arranged for washing. Excellent condition.

**CANNON STEAM JACKETED ENAMEL-LINED PANS**, 10 and 25 gallons. All new and unused.

**DOULTON 25-gal. COPPERS** with lids. **NEW** and unused.

**WELDED VESSELS** of all types, in mild steel or stainless. Fabricated to customer's specifications.

**C. BARBER LTD.**

**SILVERDALE GARDENS**

**HAYES MIDDLESEX**

Telephone—Hayes 2735/6

**7 BRAND NEW Jacketed STERILIZING VESSELS**—7 ft. long by 3 ft. diam., complete with fittings.

**2—18 in. KEK PLATE MILLS**, complete with feeders, delivery bins, motors and entablature.

**9—Worssam ROTARY PRESSES.**

**POWDER DRESSING OR SIFTING MACHINES.**

**1—Johnson FILTER PRESS**—47 plates, 32 in. sq.

**1—Johnson FILTER PRESS**—30 plates, 25 in. sq.

**Wood FILTER PRESS**—69 plates, 2 ft. 8 in. sq.

**24 in., 30 in. and 36 in. HYDRO EXTRACTORS.**

**Heavy Cake CRUSHING MILL**—2-pair high, by Nicholson.

**"U"-shaped Horizontal Jacketed MIXER**—7 ft. long, 3 ft. wide, 3 ft. 3 in. deep, belt and gear driven.

**3—5-roll REFINERS** by Baker Perkins.

**1—No. 1A Water-cooled CIRCULATOR MILL.**

**2—Excellent Nickel-lined Jacketed TILTING PANS.**

**5—Excellent Porcelain DISC MILLS.**

**1—Very Fine GARDNER SIFTER and MIXER**, trough 5 ft. 9 in. by 24 in. by 28 in. deep, with wood-built hopper, elevator, A.C. motor and starter.

**2—GARDNER 'G' size SIFTERS and MIXERS.**

**2—GARDNER 'H' size steam jacketed MIXERS.**

**6—JOHNSON FILTER PRESSES** 30 chamber 24 in. square.

**RICHARD SIZER, LIMITED, ENGINEERS, HULL.**  
Telephone: 31743.

PHONE 98 STAINES

**1,500 gal. ALUMINIUM ENCLOSED CYLINDRICAL TANK.** DITTO (two) 600 gal. With loose lids. **100 gal. ENCLOSED S.S. MIXER**, 220/1/50. (Water jacketed.)

**JACKETED "U"-TROUGH MIXER/DRYERS**, 6 ft. 3 in. by 2 ft. 3 in. by 2 ft. 7 in.

**STAINLESS STEEL ENCLOSED ELEVATOR/CONVEYOR**, 40 ft. long.

**30, 40, 60 and 100 gal. WELDED STEEL CYLINDRICAL JACKETED MIXERS**, 400/3/50.

(Twelve) **"Z"-BLADE MIXERS** up to 36 in. by 30 in. by 26 in. deep.

**DITTO 20 in. by 19 in. by 16 in. JACKETED, VACUUM, TILTING TYPE.**

**PUMPS, CONDENSERS, HYDROS, AUTOCLAVES, STILLS, OVENS, DRYERS, BOILERS, etc.**

**HARRY H. GARDAM & CO., LTD.,**

**STAINES.**

**NEW STEEL DRUMS** all sizes and types, immediate delivery from Continental production. Write or phone **STEEL DRUMS LIMITED, 118, BURDON LANE, SUTTON, SURREY.** Vigilant 4886.

## FOR SALE

## 600

## SPECIAL PURCHASE OF MODERN DRYING PLANT

**TEN NEW AND UNUSED TWIN ROLL SPRAY DRIERS** with rolls 40 in. long by 32 in. diam., suitable for 60/80 lb. sq. in. W.P., fitted spray discs and air-cooled scrapers. Main drive for rolls is by 7 h.p. A.C. motor through reduction gearbox. Drier fitted with enclosed work discharge conveyors with ancillary equipment embracing two motor-driven air blowers, motor-driven 1½ in. diam. stainless steel pump, jacketed feed tank approx. 54 in. by 37 in. by 26 in. deep, and motor-driven dresser for dried material, comprising 4 ft. long by 12 in. diam. phosphor bronze mesh covered screen, with spiral distributor to bagging-off outlet.

**FOUR NEW AND UNUSED VACUUM DRYING OVENS** of mild steel welded construction, approx. 7 ft. long by 3 ft. 6 in. wide by 3 ft. 6 in. deep, fitted nine steam-heated shelves to carry thirty-six acid resisting metal trays, 36 in. long by 16 in. wide by 1½ in. deep. Davit swung door at each end, with hand-wheel closing mechanism. Oven complete with set of thirty-six trays, motor-driven horizontal wet vacuum pump, pressure and vacuum gauges, and connecting piping.

**FOUR NEW AND UNUSED WET AND DRY HORIZONTAL VACUUM PUMPS**, type PN.6, single-stage, double-acting type. Capacity approx. 200 cu. ft. per minute displacement at speed 125 r.p.m. Fitted outboard bearing with driving pulley, approx. 12 h.p. required to drive.

**GEORGE COHEN SONS & CO., LTD.,**  
WOOD LANE, LONDON, W.12.  
Tel.: Shepherds Bush 2070 and  
STANNINGLEY, NR. LEEDS.  
Tel.: Pudsey 2241.

**HELLBRON.**—Offers are invited for 'Dictionary of Organic Compounds,' edited by Hellbron and Bunbury, 1943 edition, in three volumes, published by Eyre & Spottiswoode. Vol. I, new revised edition: Vols. II and III, reprinted with 1943 supplement. The volumes are unmarked, practically unused, and are of considerable value for reference purposes. **BOX NO. C.A. 3292, THE CHEMICAL AGE, 154, FLEET STREET, LONDON, E.C.4.**

**ONE TORRANCE MICRO TWIN-ROLLER MILL.** Cast rolls, 14 in. by 8 in. Water cooled. Fast and loose pulley-drive.

**TWO DE LAVAL SEPARATORS, VEE-BELT DRIVE.** Good condition.

**THOMPSON & SON (MILLWALL), LIMITED,**  
CUBA STREET, LONDON, E.14. TEL. EAST 1344

**"PEARL" 3 in. by 5 in. VERTICAL 3-THROW RAM PUMP** for sale. Excellent condition. **GRAY KNIGHT AND CO., LTD., 61, STOCK STREET, LONDON, E.13.**

**600 KW. HEWITTIC GLASS BULB MERCURY ARC RECTIFIERS** complete with Mains Transformer and Breco Regulator. Output 80/300 volts D.C.—Further details from: **WHITEFIELD MACHINERY & PLANT LIMITED, COBDEN STREET, SALFORD, 6.** Tel.: Pen. 1373/4.

**TWO FILTER PRESSES** by Johnson, 40 in. square plates with centre feed. 29 plates. Hand and hydraulic closing gear.  
**THOMAS MITCHELL & SONS LIMITED, BOLTON.**

## FOR SALE

**SACK AND BAG MERCHANTS AND MANUFACTURERS.** New and reconditioned for Home and Export. (Use JUTEX for sack repairing). **ALTRINCHAM JUTE LTD., WRIGHT STREET, BROADHEATH, ALTRINCHAM, CHESHIRE.**

**STAINLESS STEEL STEAM JACKETED ENCLOSED VACUUM PANS,** Hemispherical. 3 ft. 8 in. at top by 1 ft. 10 in. deep at centre with 1½ in. bore bottom centre outlet. Bolted-on domed cover, fitted with two 6 in. sight glasses, 1 in. and 1½ in. bore flanged branches and thermometer pockets. Polished internally and suitable for 28 in. vacuum. Mild steel jacket. Working pressure 30 lb. p.s.i. Mounted in mild steel angle stand. Unused.

**STAINLESS STEEL PLATE HEAT EXCHANGER** by A.P.V. CO., LTD. Type HH. 76 plates 43 in. by 16 in., total projected area 346 sq. ft. Hydraulically operated opening and closing gear.

**STAINLESS STEEL CRYSTAL DRIER** by MITCHELL, 3 ft. 6 in. diam. by 1 ft. 6 in. deep. **STEAM JACKETED** flat bottom with two S.S. paddles underdriven through bevel gearing from direct-coupled 1 h.p. 400/3/50 geared motor. Jacket working pressure, 15 lb per square inch.

**M.S. SPIRIT EXTRACTION PLANT,** comprising 3 ft. diam. by 5 ft. deep extractor with dished bottom jacketed for 5 lb. per square inch working pressure, condenser, separator, storage tank.

**KESTNER HORIZONTAL TUBULAR EVAPORATOR,** having six turns copper tube 1½ in. bore by 6 ft. long, complete with copper reception pot.

**STEAM JACKETED COPPER STILLs,** 150 gallons capacity. Fitted swan-neck, sight and light glasses, etc., and complete with copper coil condenser. Jacket working pressure 40 lb. per square inch.

**STEAM JACKETED COPPER BOILING PAN,** 100 gallons capacity. Bolted-on cast-iron jacket suitable for 40 lb. per square inch working pressure.

**DOUGH MIXER,** having "U" trough 1 ft. 5 in. by 1 ft. 7 in. wide at top by 2 ft. deep. Sheet brass trough, cast-iron ends, G.M. agitator. Belt driven and arranged for hand tilting.

**M.S. HORIZONTAL "U" TROUGH MIXER,** 3 ft. by 1 ft. 9 in. by 2 ft. deep. Fin-type agitating gear belt driven through helical gearing from fast and loose pulleys. Arranged for hand tilting.

**Cast-iron VACUUM DRYING OVEN** by TAYLOR, 4 ft. by 2 ft. 10 in. by 4 ft. 6 in. front to back, having ten steam-heated M.S. platens pitched at 3 in. Hinged door at each end. Steam working pressure 15 lb. per square inch.

**HARRISON-CARTER DISINTEGRATORS,** sizes 2½ and 00. Belt driven.

**PROCESS & CHEMICAL ENGINEERING CO., LTD.,**  
6/8. NORTHUMBERLAND PARK,  
TOTTENHAM,  
LONDON, N.17.

Phone: TOTtenham 2436 (3 lines).

## PROPERTY

**FACTORY** equipped for animal foodstuffs for disposal in London. Floor area, 18,000 sq. ft. with large covered yards of 10,000 sq. ft. Apply **LEOPOLD FARMER AND SONS, FACTORY AGENTS, 46, GRESHAM STREET, LONDON, E.C.2.** (Tel.: Mon. 3422.)

## WANTED

**INDUSTRIAL BY-PRODUCTS, LTD., 16, Philpot Lane, London, E.C.3.** will be pleased to receive particulars of any by-products, waste materials and residues for disposal.

---

**WANTED**

---

**WANTED—STAINLESS STEEL STORAGE TANKS,** 1,000 to 2,000 gallons capacities. Glass lined might suit. **BOX No. C.A. 3302, THE CHEMICAL AGE, 154, FLEET STREET, LONDON, E.C.4.**

---

**SERVICING**

---

**CRUSHING. GRINDING, MIXING and DRYING for the trade.**

**THE CRACK PULVERISING MILLS LTD.**  
Plantation House,  
Mining Lane,  
London E.C.2

**GRINDING, CRUSHING AND GRADING**

**FINE GRINDING LTD.,**

**BLACKHOLE MINE, EYAM**

**TELEPHONE: EYAM 227**

**PULVERISING** of every description of chemical and other materials for the trade with improved mills, wharfage, and storage facilities. **THOS. HILL-JONES LTD., "INVICTA" WORKS, BOW COMMON LANE, LONDON, E. TELEGRAMS: "HILL-JONES, BOCHURCH LONDON." TELEPHONE 3285 EAST.**

**WET AND DRY GRINDING, Micronising, Grading and Mixing of Minerals and Chemicals for all trades.** Also suppliers of ground zircon, sillimanite, fused silica, precision casting materials and a wide range of ground minerals.

**W. PODMORE & SONS, LTD.,**  
SHELTON, STOKE-ON-TRENT.  
Phones STOKE-ON-TRENT 2814 & 5475

---

**PATENTS & TRADE MARKS**

---

**KINGS PATENT AGENCY, LTD.** (R. T. King, A.M.I.Mech.E., Patent Agent), 146a, Queen Victoria Street, London, E.C.4. **ADVICE Handbook, and Consultation free** Phone: City 6141.

---

**WORKING NOTICE**

---

**THE Proprietors of British Patent No. 632,533, for IMPROVEMENTS IN OR RELATING TO CORROSION INHIBITION,** desire to enter into negotiations with a firm or firms for the sale of the patent or for the grant of licences thereunder. Further particulars may be obtained from **MARKS & CLERK, 57 and 58, LINCOLN'S INN FIELDS, LONDON, W.C.2.**

---

**EXPORTS**

---

**LATIN AMERICA.**—A \$2,500 million export market must be approached in the buyer's own language. Specimen copies of the Spanish and Portuguese editions of **INDUSTRIA BRITANICA,** the leading British monthly trade journal covering these nineteen Republics, together with details of free translation services available on request to: **INDUSTRIA BRITANICA, BOUVERIE HOUSE, FLEET STREET, LONDON, E.C.4.**

---

**BUSINESS OPPORTUNITIES**

---

**CHEMICAL MANUFACTURERS** seek to acquire substantial interest in reputable and well established Chemicals Export Merchant House with view to close collaboration in export markets. **BOX No. C.A. 3307, THE CHEMICAL AGE, 154, FLEET STREET, LONDON, E.C.4.**

**PARTNERSHIP** offered **GENTLEMAN** outstanding sales ability, work from **BIRMINGHAM** Office. No territory restrictions. Sales expectation from new tried product exceedingly high. £2,000 investment, fully secured, ensures Executive standing and certainty excellent income. Car owner essential. **FIELD, 70/76, ALCESTER ROAD SOUTH, KING'S HEATH, BIRMINGHAM.** (Telephone: Hig 3191/2.)

For Classified Advertising  
**THE CHEMICAL AGE**  
PULLS IN RESULTS

---

**HYDROGEN PEROXIDE**

---

Concentrated Qualities Dyestuffs & Chemicals

**COLE & WILSON, LTD.**

24, Greenhead Road, **HUDDERSFIELD**  
Phone: Huddersfield 1993. Grams: 'Colour' Huddersfield

**Filter**  
**Crucibles**  
of  
**Porous Porcelain**

retain the finest precipitates and filter rapidly. They are not affected by acids, remain constant in weight within very fine limits and can be heated to high temperatures.

Made by

**The WORCESTER**  
**ROYAL PORCELAIN CO. LTD.**

and  
Supplied by all recognised Laboratory  
Furnishers

## INDEX TO ADVERTISERS IN THIS ISSUE

	Page		Page
Aerox, Ltd.	864	Kestner Evaporator & Engineering Co., Ltd.	903
Alchemy, Ltd.	Cover Two	Key Engineering Co., Ltd. (The)	Cover Two
Audley Engineering Co., Ltd.	863	Kilner, John, & Sons (1927)	903
		Klinger, Richard, Ltd.	870
British Tar Products, Ltd.	872	Leigh & Sons Metal Works, Ltd.	903
Chemitrade, Ltd.	Cover Two	Metal Containers, Ltd.	Back Cover
Classified Advertisements	904, 905, 906, 907	Philips Electrical, Ltd.	869
Cole & Wilson, Ltd.	907	Pulsometer Engineering Co., Ltd.	872
Crosfield, J., & Sons, Ltd.	862	Pyrene Co., Ltd. (The)	864
Cruickshank, R., Ltd.	Front Cover	Shandon, E. R., & Co., Ltd.	868
Dryden, T., Ltd.	866	Simon, Richard, & Sons, Ltd.	903
Farwig, J. F., & Co., Ltd.	866	Stanton Instruments, Ltd.	867
Foxboro-Yoxall, Ltd.	Cover Three	Thermal Syndicate (The)	868
Greening, N., & Sons, Ltd.	861	Unifloc, Ltd.	908
Haughton's Metallic Co., Ltd.	903	Worcester Royal Porcelain Co., Ltd. (The)	907
Hess Products, Ltd.	865		

**UNIFLOC**  
REGD. TRADE MARK

## Plant for the Chemical Industry

for ACID NEUTRALIZATION, CLARIFICATION OF LIQUIDS, DEWATERING OF SLUDGES, EFFLUENT PURIFICATION, FILTRATION AND FLOCCULATION, PICKLING LIQUOR TREATMENT, PURIFICATION OF TRADE WASTE SEDIMENTATION AND THICKENING, SEPARATION OF SOLIDS FROM LIQUIDS, SODA RECOVERY. WET MATERIAL HANDLING

including  
AGITATORS CAUSTICIZERS, CLARIFIERS, CLASSIFIERS, CONVEYORS, DEWATERING MACHINES, ROTARY, VACUUM FILTERS, SAND WASHERS, SLUDGE PUMPS, THICKENERS, etc.

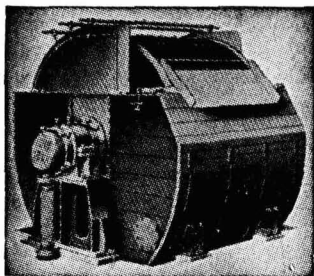

*Rotary Pulp Washing Machine, with Pitch Pine Trough, Wash Gear and Scraper Knife*

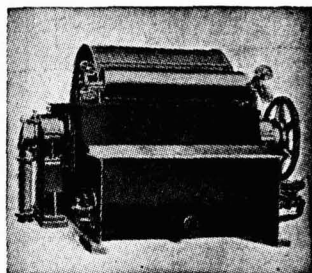

*Rotary Vacuum Filler, with Take-off Roller and Repulper*

**UNIFLOC LIMITED**  
— SWANSEA —

Phone : Swansea 55164 (3 lines)  
Grams : Unifloc, Swansea



# FOXBORO

REG. U.K. TRADEMARK NO 683659

## Instruments

# GRAPHIC & CONSOLE

### MODEL 53/58 CONSOTROL

A complete recorder and controller small enough for graphic or console presentation and occupying a panel space no larger than 6" x 6".

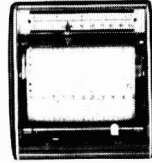

### MODEL 52 CONSOTROL

Another high-grade instrument in the same series but designed for indicating and controlling. The case dimensions are 7 3/4" high by 3 1/2" wide.

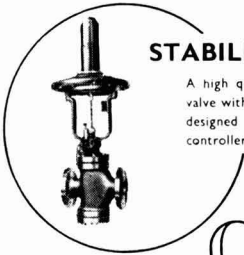

### STABILFLO VALVES

A high quality air-operated control valve with exponential characteristic, designed especially for use with the controllers shown on this page.

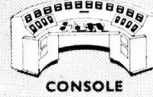
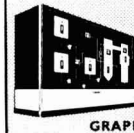

GRAPHIC

CONSOLE

# CONVENTIONAL

### MODEL 40 RECTANGULAR

A well-known and well-proven instrument, measuring 17" high by 14 1/2" wide and available for indicating, recording and/or controlling with either mechanical or Dynalog electronic measuring systems.



### ROUND FORM SERIES

This series includes the simple concentric indicator, the recorder, as illustrated, together with the indicating or recording controller with On/Off or Proportional action.



# FOXBORO-YOXALL LTD

LOMBARD RD., MERTON, LONDON, SW19

TELEPHONE NUMBER LIBerty 2461.4



CONVENTIONAL



USE THE RIGHT CONTAINER

— and keep a  
jump ahead!

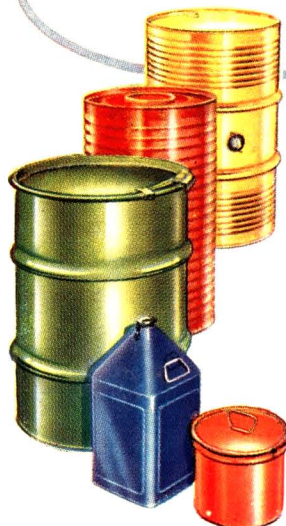

YOUR PRODUCTS ARE PROTECTED BY

# METAL CONTAINERS

FOR SAFETY IN TRANSIT

METAL CONTAINERS LTD., 17 WATERLOO PLACE, PALL MALL, LONDON  
WORKS: ELLESMERE PORT & RENFREW.

ASSOCIATED COMPANIES OVERSEAS  
M-W.104