

24.12.55

THE Chemical Age

VOL. LXXIII

3 DECEMBER 1955

No. 1899

SULPHUR

"Daffodil Brand"

DOUBLE REFINED ROLL SULPHUR

99.8/100%

SUBLIMED FLOWERS OF SULPHUR

B.P. and Commercial

POWDERED SULPHUR

All meshes

DISPERSIBLE SULPHUR

WETTABLE SULPHUR

BLACK SULPHUR

GREEN SULPHUR

"ALL GRADES FOR ALL TRADES"

Home Trade & Export

PRICE STUTFIELD & Co., LTD.

110, FENCHURCH STREET,

LONDON E.C.3.

Phone :
Royal 7011/2

Cables:
Exconsec, Fen, London

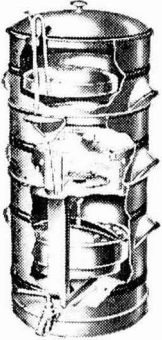

With a Wells' waste oil filter you can use your oil several times over and change it more often. A thoroughly reliable supply of oil is assured with the use of Wells' special filter pads which work in conjunction with Wells' patent syphon feed. The oil delivered from a Wells' filter can be used with complete confidence.

Write for fuller particulars of these filters

Delivery of Oil Filters and special "Wells' Filter Pads from Stock"

**Also makers of
OIL CABINETS, BARREL POURERS &
PORTABLE PARAFFIN HEATER PLANTS**

Drying Trays

- IN HARD RESISTANT VITREOUS ENAMEL
- SPECIALLY PROCESSED TO GIVE MAXIMUM SERVICE
- ALL CORNERS AND EDGES ROUNDED
- SIZES TO SUIT CUSTOMERS REQUIREMENTS
- FINISHED IN GREEN OR OTHER SELECTED COLOUR

NATIONAL ENAMELS LTD.
53, NORMAN ROAD, GREENWICH
LONDON, S.E.10.
 Telephone : Greenwich 2266-7 and 2429

cannot jam or blow steam. Unique in design, foolproof in operation.

"Simplicity" Steam Traps have only one moving part—a free floating stainless steel sphere. Each trap is guaranteed. Send for a trap on trial. Write for fully descriptive pamphlet, No. ST9A.

THE KEY ENGINEERING CO. LTD.

4 Newgate Street, London, E.C.1

Telephone: City 1185/6/7

and at Trafford Park, Manchester, 17 Telephone : Trafford Park 1903

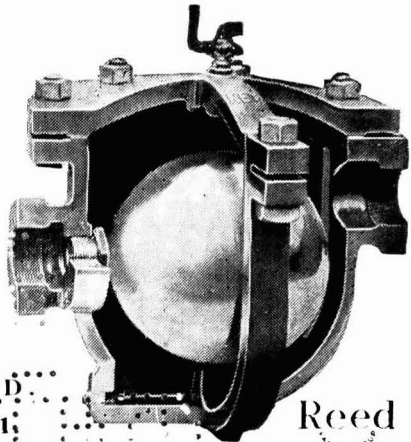

Reed
LONDON

THE SOLWAY PLANT

*A substantial contribution to
the national economy*

With the first Solway Plant in production, British industry is assured of an additional supply of 100,000 tons of sulphuric acid a year at economic rates. This vital commodity, essential to so many different industrial processes, will be produced without any additional call on foreign currency, since the Solway Plant operates with raw materials freely available on site. It will produce, in addition, a valuable co-product in the shape of 100,000 tons yearly of high-grade Portland cement.

There is no doubt that the Solway Plant, by providing an economic supply of sulphuric acid used in the manufacture of many currency-earning exports, and by helping to speed important building construction in the North-West, will make a substantial contribution to the national economy.

SOLWAY CHEMICALS LTD., WHITEHAVEN, CUMBERLAND

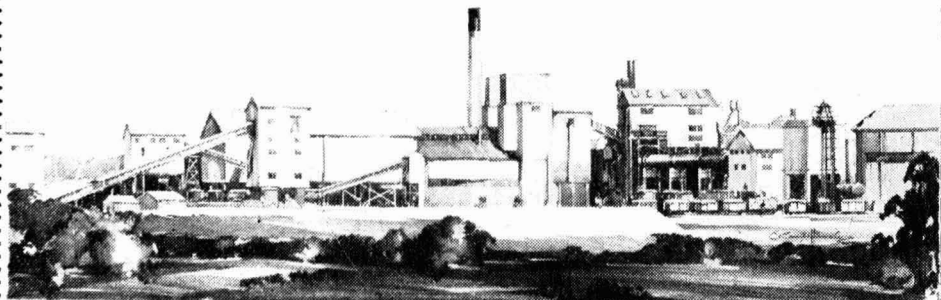

THE SOLWAY PLANT

The foundations of the Chemical Plant Hopper and Conveyors were supported on this site by 220 15-inch and 19-inch diameter bored piles constructed by us for Marchon Products Limited.

This type of pile was chosen because of the proved extreme mobility of the unit. Other advantages are that the piles can be constructed adjacent to existing buildings without harmful vibrations.

One of the contracts was under the direction of Messrs. W. V. Zinn, Consulting Engineers, Liverpool and London.

THE CEMENTATION COMPANY LIMITED

39, VICTORIA STREET, LONDON, S.W.1.

Head Office:

BENTLEY WORKS

DONCASTER

For their NEW CEMENT PACKING PLANT at Whitehaven, MESSRS. SOLWAY CHEMICALS LTD.

chose the

**“DAYLOR” COMBINED AUTOMATIC
PACKING AND WEIGHING
MACHINE**

**“DAYLOR” AUTOMATIC DUST
COLLECTOR
VIBRATING SCREEN AND
ANCILLARY PLANT**

by

J. DARNLEY TAYLOR LIMITED

100 VICTORIA STREET, LONDON, S.W.1.

Telephone: Victoria 5677

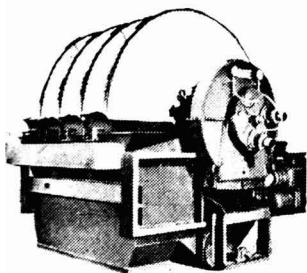

DISC FILTER

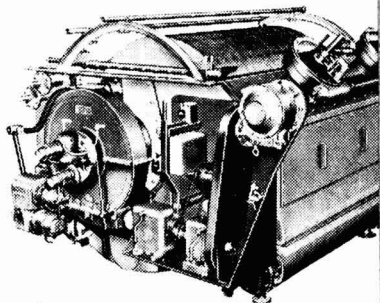
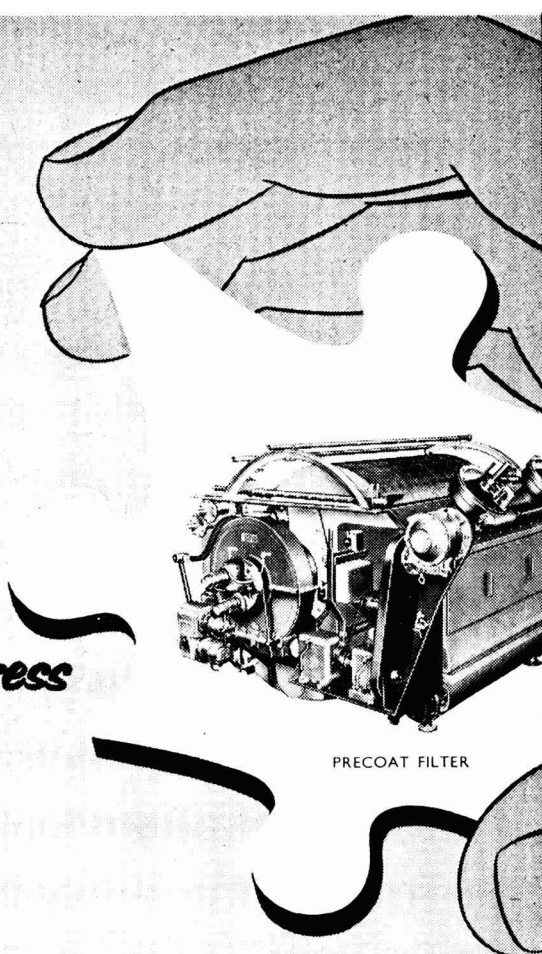

PRECOAT FILTER

EIMCO filters fit your process

Whatever your filtration problem there is an Eimco Filter specially designed for the job. Eimco Filters have been built in close collaboration with industry for many years, and their world-wide use testifies to their efficiency and reliability. They are used in the Cement, Chemical, Coal, Food, Paper, Petroleum, Sewage, Starch, Sugar and other industries for Clarifying, Dewatering, Drying, Washing and other recovery processes.

Write for more information concerning the wide range of Eimco equipment available. Our free testing facilities and world-wide experience are at your disposal.

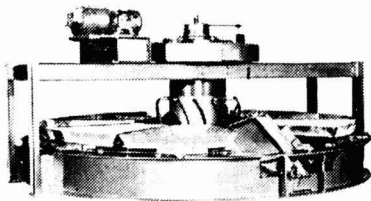

PAN FILTER

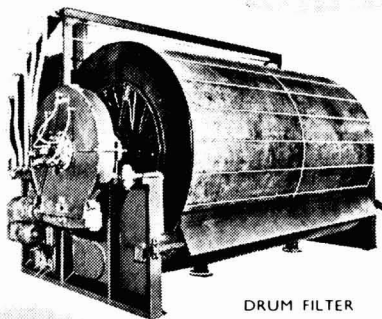

DRUM FILTER

EIMCO (GREAT BRITAIN) LTD

TEAM VALLEY GATESHEAD-ON-TYNE 11 TEL LOW FELL 7-7241 GRAMS EIMCO-GATESHEAD 11

EIMCO

EIMCO (GREAT BRITAIN) LTD

PRINCES HOUSE PICCADILLY LONDON W.1

TELEPHONE GROSVENOR 210

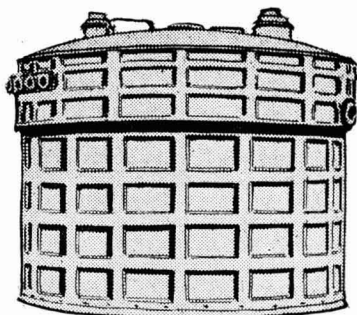

Quiet Satisfaction

The quiet satisfaction that comes from a job well done; from a job that we know will stand the test of time. That's how we feel about the part we played in the Fabrication of the lead-work for Solway Chemicals Ltd. new plant at Whitehaven.

*Satisfaction—
that's our service to industry*

MILLS PACKARD
CONSTRUCTION COMPANY, LIMITED

Duke Street, Ipswich, Suffolk. Tel : 2177

ANNOUNCEMENT

FAWCETT PRESTON & CO. LTD. OF BROMBOROUGH AND FINNEY PRESSES LTD. OF BIRMINGHAM, BOTH MEMBERS OF THE METAL INDUSTRIES GROUP OF COMPANIES, ANNOUNCE THE FORMATION OF A JOINT SALES AND SERVICE COMPANY WITH THE TITLE :—

FAWCETT-FINNEY LTD.



The new company will be responsible for sales services in connection with all products of Fawcett Preston & Co. Ltd. and Finney Presses Ltd., including :—

“**FAWCETT**” Hydraulic pumps and valves for water up to 250 H.P. Baling presses for all fibres and metals. Industrial and engineering presses.

“**FINNEY**” Greer-Mercier hydro-pneumatic accumulators. Hydraulic pumps and valves for oil. Hydraulic presses for the plastics and rubber trades. Hydraulic power packs and systems.

“**HOLLMAN**” Vertical and horizontal open-throat presses.

“**DAVIS-STANDARD**” extruding machines and ancillary equipment for plastics and rubber with a full range of dies, heads and gear for the wire covering and general plastics extrusion trade.

“**BAKER**” automatic moulding machines for the fast curing powders from 25 to 150 tons.

“**STUBBE**” Injection moulding machines.

Facilities for design and production of special-purpose plant and machinery for the engineering, ship-building and chemical trades are to be intensified at Bromborough and Birmingham. The co-ordination of both manufacturing programmes and the institution of a joint sales Company is designed to provide a greatly improved all-round service.



HEAD OFFICE & MIDLAND REGION SALES

27 Berkley Street, Birmingham 1

LONDON & SOUTHERN REGION SALES
Universal House, 60 Buckingham Palace Road, S.W.1

NORTHERN REGION SALES
Dock Road, Bromborough, Cheshire

WESTERN REGION SALES
28 Mayfield Park South, Fishponds, Bristol

Solve your pumping problems

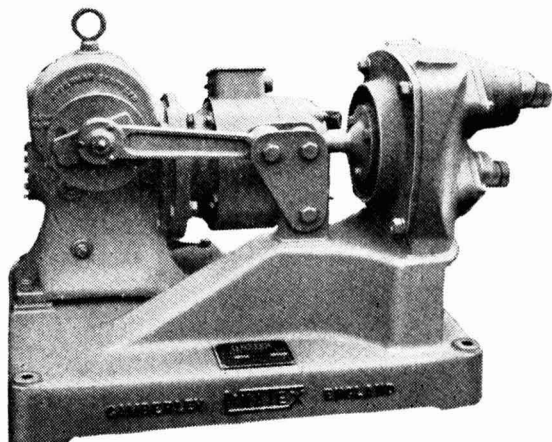

with motor or

THE LINATEX MOTOR DRIVEN DIAPHRAGM PUMP

Built on a cast iron base, this pump has an aluminium body and an electric geared motor drive. The body is lined throughout with Linatex rubber and employs solid Linatex Valves and Diaphragm with resistance to chemicals up to 65° C. Rubber bearings, requiring no lubrication, give trouble-free operation and reduce maintenance.

- Positive action
- Self priming
- No packing
- Continuous operation
- 8 Galls. min. capacity

Linatex, being 95% pure, natural rubber, has proved invaluable to all branches of industry as a wear and corrosion resistant material. Now, Wilkinsons, its makers, have adapted its enduring qualities to the problems of pumping. They have designed a range of pumps which, by incorporating Linatex into their construction, are capable of withstanding the heaviest wear from abrasives and the corrosive effects of most chemicals. The two Linatex pumps illustrated below are both specially designed to meet the needs of the chemical and allied industries.

manual

THE LINATEX HAND OPERATED DIAPHRAGM PUMP

A portable, easily operated pump specially suitable for emptying vessels, sumps, pits, etc. Like the motor driven version it is lined with Linatex and has rubber bearings.

- Light weight
- Simple operation
- No packing
- Self priming
- 8 Galls. min. capacity

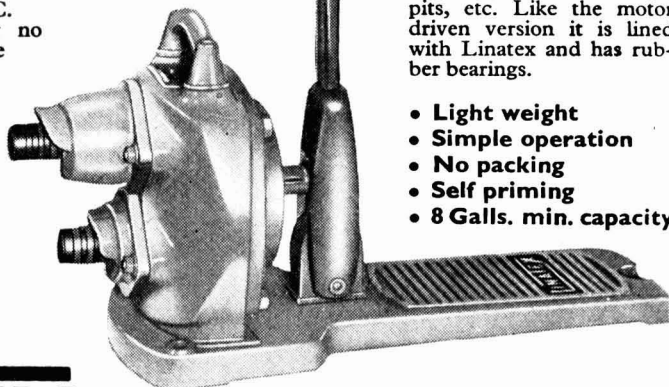

LINATEX pumps

Please write for full particulars stating whether you would like our resident engineer in your district to call on you. He will gladly assist you with your pumping problems.



WILKINSON RUBBER LINATEX LIMITED
 FACTORIES AND DISTRIBUTORS THROUGHOUT THE WORLD

CAMBERLEY · SURREY
 TEL.: CAMBERLEY 1595

INDUSTRIAL PLANT *and* SUPPLIES

**BOILERS and
ACCESSORIES**

**PIPES and
FLANGES**

**STEEL and ALLOY
SCAFFOLDING
and LADDERS**

**WELDED and
RIVETTED VESSELS**

**AIR and GAS
RECEIVERS**

**ASBESTOS
PACKINGS and
JOINTINGS**

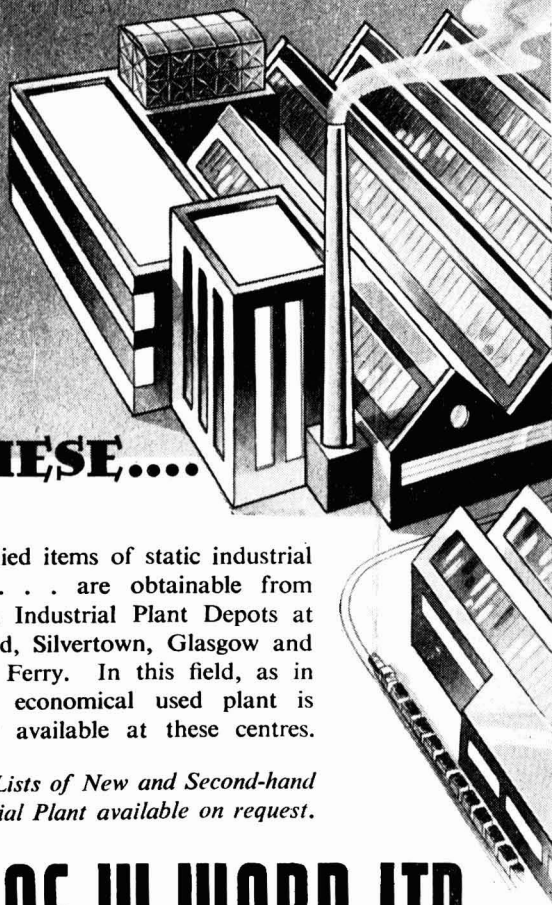

THESE....

and allied items of static industrial plant . . . are obtainable from Ward's Industrial Plant Depots at Sheffield, Silvertown, Glasgow and Briton Ferry. In this field, as in others, economical used plant is usually available at these centres.

Stock Lists of New and Second-hand Industrial Plant available on request.

THOS. W. WARD LTD
INDUSTRIAL PLANT DEPARTMENT
ALBION WORKS · SHEFFIELD

London Office—

BRETENHAM HOUSE · LANCASTER PLACE · STRAND · W.C.2

MOND *Chemical Products*

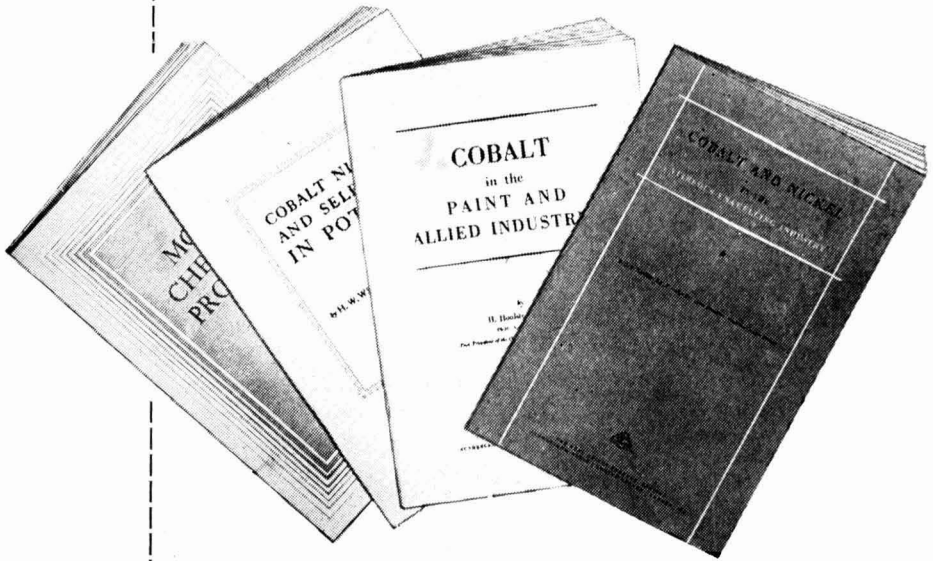

Nickel and Cobalt Oxides and Salts Selenium Tellurium

We issue the following publications on uses of Mond Chemical Products :

Cobalt and Nickel in the Vitreous Enamelling Industry. By J. E. Hansen, B.Sc., F.Am.Cer. Soc.

Cobalt, Nickel and Selenium in Pottery. By H.E. Webb, O.B.E., D.Sc., F.R.I.C., M.I.Chem.E.

Cobalt in the Paint and Allied Industries. By H. Houlston Morgan, Ph.D., A.R.C.S., F.R.I.C.

Mond Chemical Products. A list of products we regularly supply.

Copies of any of the above publications will be sent free on request.

THE MOND NICKEL COMPANY LIMITED

Thames House · Millbank · London · S.W.1





PUT AWAY THAT COIN!

That's no way to plan a lighting installation!

Nothing must be left to chance . . . type of fitting,
spacing, mounting . . . quality of distribution . . .
total wattage, and individual lighting points.

We'd like to show you the way *we* go about a job.

We'd like to show you some lighting specifications
we have prepared. Please call us in and talk it over.

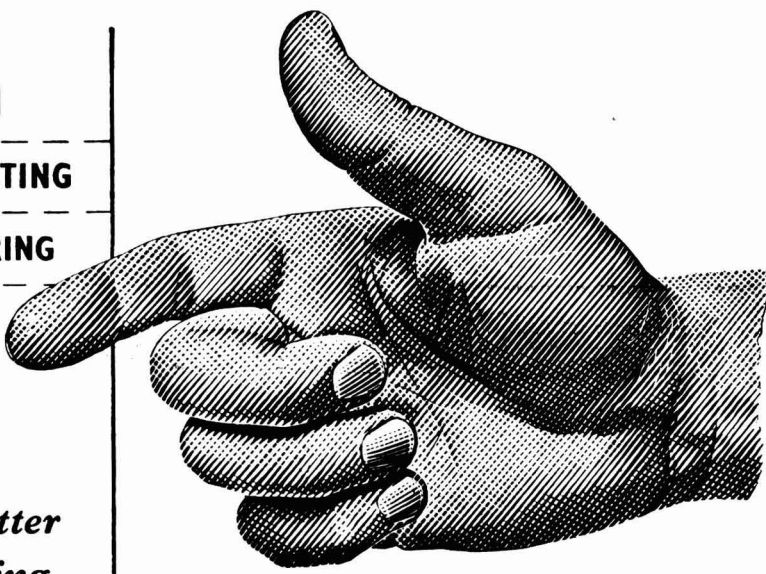

BENJAMIN

ILLUMINATING

ENGINEERING

SERVICE

*better
lighting
by*

BENJAMIN REGD.

THE BENJAMIN ELECTRIC LTD. TOTTENHAM * LONDON N. 17

Telephone: TOTtenham 5252 (3 lines)

Cables: 'Benjalect, Southtot, London'

BIRMINGHAM: 5 CORPORATION STREET, BIRMINGHAM, 2. Tel: MIDland 5197 · LEEDS: 49 BASINGHALL STREET, LEEDS, 1. Tel: Leeds 35979

Smee's 50

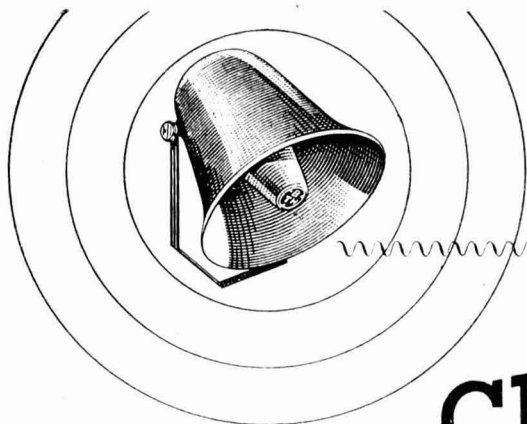

CLEAR AS A BELL

CLEARCALL

Industrial Communication System

With "Clearcall", speech can be clearly heard through the din of a noisy factory, or it can be adjusted for quiet surroundings. "Clearcall" components are of rugged industrial design, and will not fail in spite of dirt, damp, and rough usage.

The equipment is suitable for iron and steel works, rolling mills, etc., paint and varnish factories, chemical works.

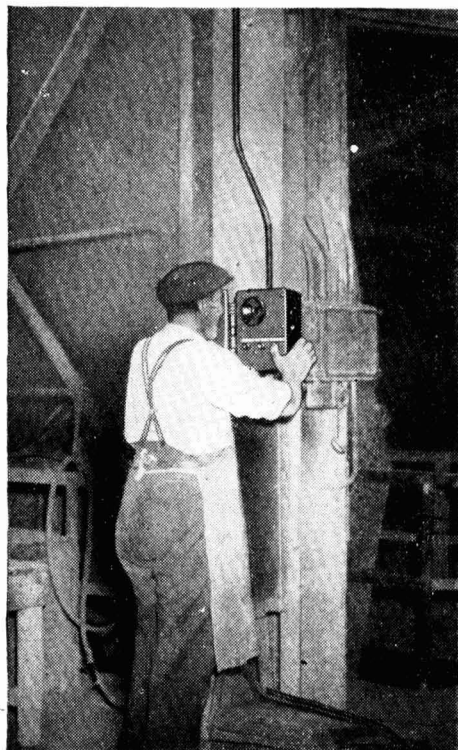

SAFE!

"Clearcall" components are the subject of an "intrinsic safety certificate" in respect of Pentane Vapour etc. Details on application.



THE
BRITISH THOMSON-HOUSTON
COMPANY LIMITED, RUGBY, ENGLAND

A 4582

Member of the AEL group of companies

● **TEXTILE CHEMICALS**

LAURYL PYRIDINIUM CHLORIDE
CETYL PYRIDINIUM CHLORIDE
 Quaternary Ammonium Compounds of high surface activity.

● **PHARMACEUTICAL CHEMICALS**

BENZALKONIUM CHLORIDE
(Distributed by Bayer Products Ltd.)
CETYL DIMETHYL BENZYL AMMONIUM CHLORIDE
CETYL TRIMETHYL AMMONIUM CHLORIDE
CETYL PYRIDINIUM CHLORIDE
 Quaternary Ammonium Compounds of high purity with outstanding Germicidal properties.

● **COSMETIC CHEMICALS**

STEBAC An outstanding base for the hairdressing industry incorporating Stearyl Dimethyl Benzyl Ammonium Chloride. The corresponding Cetyl compound is also available.

● **RUBBER CHEMICALS**

ZINC DIETHYL DITHIOCARBAMATE
ZINC DIMETHYL DITHIOCARBAMATE
TETRAMETHYL THIURAM DISULPHIDE
TETRAETHYL THIURAM DISULPHIDE

Accelerators used in Foam rubber processing.

● **ANTISTATIC CHEMICALS**

HEATEX A long chain Quaternary incorporating outstanding anti-static properties to plastics, synthetic fibres, etc.
ANTIMIDE A fatty Ethanolamid with Quaternary groups particularly useful for discharging static when processing Nylon.

INDUSTRIAL CHEMICALS

N. MONO ETHYL ANILINE
NN. DIETHYL ANILINE

We shall also shortly be introducing experimental quantities of the ring substituted Primary, Secondary and Tertiary Ethyl Anilines.

DYESTUFFS INTERMEDIATES

● **ALKYL CHLORIDES**

STEARYL CHLORIDE · CETYL CHLORIDE
MYRISTYL CHLORIDE · LAURYL CHLORIDE
BUTYL CHLORIDE

Intermediates for the manufacture of Amines, Quaternary Ammonium Compounds and Grignard compounds.

CHLORO-METHYL METHYL ETHER A useful Chloro-Methylating agent and an intermediate in the manufacture of ion exchange resins.

para CHLORO-METHYL TOLUENE
 At present in small scale production. A potential

route to Terephthalic Acid.

ANHYDROUS HYDROCHLORIC ACID GAS

Solutions in various alcohols and ethers. Extremely useful materials for Esterifications and reactions involving the use of Anhydrous HCL and for the preparation of Anhydrous Amine Salts.

CHLORINATED COMPOUNDS

LEDALOG
CHEMICALS LTD

ELEY ESTATE, ANGEL ROAD, EDMONTON, LONDON N18

Cables & Telegrams **LEDAKEM LONDON**

Telephone **EDMONTON 6322/3/4**

The *inside* secret of successful packaging

'ALKAPAKS'

POLYTHENE FILM

DRUM LINERS

—with the circular base

• • • • •

fit the drum better •

easier to insert •

less stressed when full •

fully supported at the base

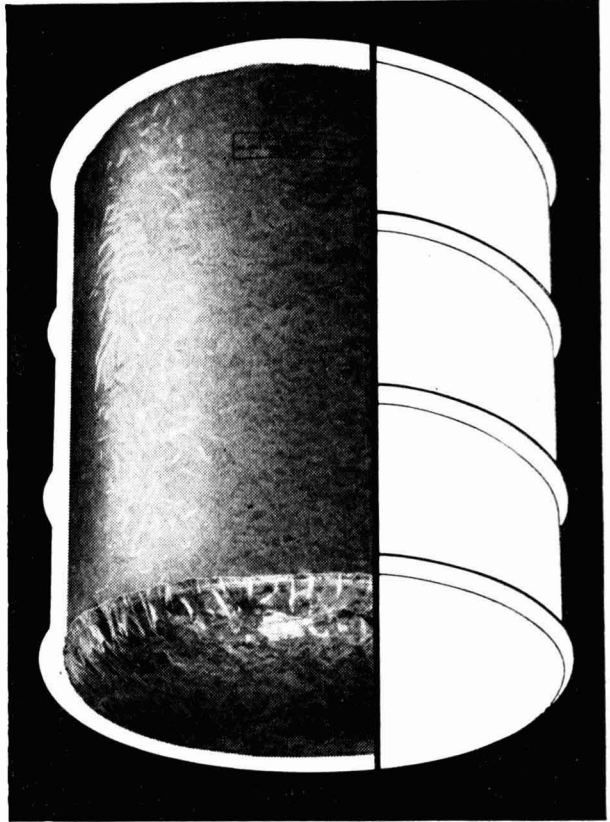

Made in a range of standard sizes for drums from 3 to 45 gallons : other sizes tailor-made to order.

With 'Alkapaks' circular-base liners, almost any product can be packed in untreated drums—and for many products, lighter, cheaper, non-returnable fibre-board and plywood kegs can be used.

'ALKAPAKS' POLYTHENE FILM
Regd.

Drum, sack and case liners, bags, envelopes and sheeting are all made from *VidQueen* brand of polythene film.

THE PAPER GOODS MANUFACTURING CO. LTD. WESTMEAD ROAD, SUTTON, SURREY
 Telephone: *Vigilant 8216*

P.G.17a



MAXIMUM OPERATING
TEMPERATURE 180°C

CONSTRUCTED IN
ALUMINIUM THROUGHOUT

CONVENIENT TEMPERATURE
REGULATION BY "GALLENKAMP-
SUNVIC" THERMOSTAT.



The oven illustrated has two aluminium shelves with wide rectangular perforations and four shelf positions are provided. Ventilators are fitted in the bottom and top of the oven, those at the top having adjustable openings to regulate air flow. A thermometer tubulure is fitted on the top, towards the back.

WRITE TO-DAY FOR DETAILS OF OUR COMPLETE RANGE OF
MODERN LABORATORY OVENS

A. GALLENKAMP & CO., LTD.

17-29 : SUN STREET : LONDON : E.C.2

TELEPHONE : BISHOPSGATE 0651 (9 lines)

TELEGRAMS : GALLENKAMP AVE. LONDON

STARBRIGHT FILTRATES

Metafilters secure the complete removal, by mechanical means, of suspended matter from liquids of any type and at any temperature and pressure.

No matter how fine the solids may be—colloidal or sub-microscopic—the Metafilter will remove it.

Metafilters are totally enclosed—so avoiding oxidation or loss of solvent, or escape of fumes. They are completely cleaned at the end of a run in a few minutes without opening up; and the residue and sludge discharged to waste without coming into contact with the atmosphere.

Filtrations until recently impossible are now carried out with ease.

Metafilters are available from 1 gallon to 10,000 gallons per hour, in all metals.

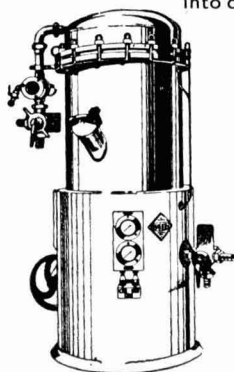

METAFILTRATION

THE METAFILTRATION COMPANY LIMITED
BELGRAVE ROAD, HOUNSLOW, MIDDLESEX

★ PHONE: HOUNSLOW 1121/2/3
GRAMS: METAFILTER, HOUNSLOW

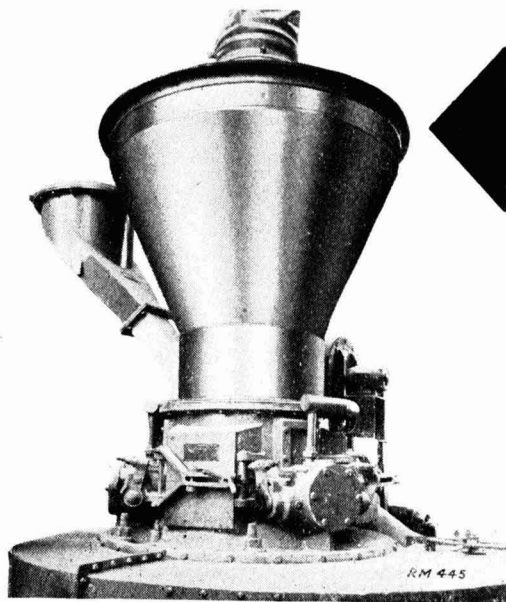

B.G.

GRINDING MILL

SIZES FROM 2 TONS TO 25 TONS PER HOUR
LOW CURRENT CONSUMPTION
SILENT OPERATION BY COMPRESSION & FRICTION
NO DUST—COMBINED DRYING
FINENESS UP TO 300 MESH

We can also supply:—
SULPHURIC ACID PLANT . ELECTROLYTIC CELLS
OXYHYDROLISERS

MORITZ

CHEMICAL ENGINEERING CO. LTD
204, Earls Court Road, London, S.W.5

Telegrams: Morichemic, London

Telephone: Frabisher 0769

INDUSTRIAL SAFETY • Fire and Accident Prevention and Protection

Nearly 100 years

since we started making Lifting Equipment. Almost a century of design, development and manufacture of the many appliances coming under this heading. It is this intensive specialised experience that guarantees the safety, quality and fitness of our products.

For all

LIFTING GEAR

consult the craftsmen

W. & E. MOORE LTD.

Poplar Testing Works,

13-31 POPLAR HIGH STREET, LONDON, E.14.

Telephones : East 2613-7 - 4601-2

R53G

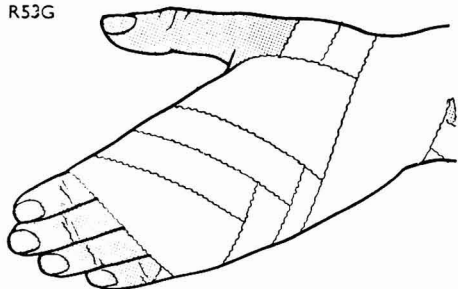

NON-PRODUCTIVE

Dermatitis, production's greatest enemy, can soon put skilled hands out of action. Rozalex is the proved safeguard against this risk. For over 25 years Rozalex have specialised in barrier creams for industry. They have provided the answer to most industrial skin irritants. Their full technical resources and experience are at your disposal on request to: Rozalex Ltd., 10 Norfolk Street, Manchester 2.

ROZALEX

BARRIER CREAMS

PROTECTION AGAINST CORROSION & CHEMICAL ATTACK

**POLYTHENE AND RIGID P.V.C.
(MATERIALS, FABRICATIONS, INSTALLATIONS)**

E.G.

**POLYTHENE TUBE AND POLYTHENE FITTINGS
WITH B.S.P. THREADS**

**POLYTHENE AND RIGID P.V.C.
PIPE LINES, DUCTING, LININGS, ETC.**

**'DENSO' TREATMENTS TO STRUCTURAL
STEELWORK**

Information and Catalogue from :

**INDUSTRIAL AND MARINE
PROTECTIVE APPLICATIONS LTD.
FOUNTAIN STREET, BARNBROOK, BURY, LANCs.
Telephone: BURY 3368/9 Telegrams: 'IMPA' BURY**

SAFER . . .

with SIEBE, GORMAN

RESPIRATORS. The Puretha Mark IV Respirator.

SELF-CONTAINED BREATHING APPARATUS for work in irrespirable atmospheres.

Oxygen and Compressed Air types

PROTECTIVE CLOTHING, Asbestos, Acid and Waterproof clothing, Goggles,

Gloves, fume and dust masks, carbon-monoxide detectors, fire extinguishers, etc.

SMOKE HELMETS.



Established 1819

SIEBE, GORMAN & CO. LTD
LONDON
EVERYTHING FOR SAFETY EVERYWHERE

Neptune Works • Davis Road • Chessington • Surrey

Telegrams : Siebe, Chessington. Telephone : Elmbridge 5900.

SG (c) 1.

• NEPRO •

LIQUID NEOPRENE PROTECTIVE COATINGS N.200

HEAVY DUTY COATING APPLIED AT OUR WORKS, FOR VALVES,
PIPES, TANKS, CHEMICAL AND MARINE PLANT, ETC.

anti-corrosive

anti-abrasive

MANUFACTURED BY

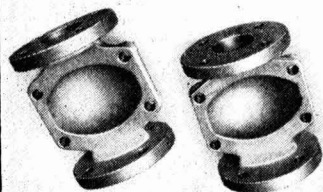

EAGLE WORKS WEDNESBURY

TEL · WED 0284 (5 LINES)

weatherproof

N.700

high-adhesion

MAINTENANCE GRADE SUPPLIED READY FOR USE, FOR PROTECTION
FROM FUME & SPLASH OF STEEL WORK AND MARINE PLANT, ETC.

We are the sole licensees in U.K. for Gates Engineering Co., U.S.A. Gaco Processes

INDUSTRIAL SAFETY • Fire and Accident Prevention and Protection

**An "EVERTRUSTY" product, backed by
our 70 years' specialised knowledge of
Industrial Safety Equipment.**



WALLACH BROTHERS LTD.
49, TABERNACLE STREET,
LONDON, E.C.2.

NON-SPARKING ← PUSH

DRAW →

SCRAPERS

14 ozs:

9 ozs:

ONE MONTH FREE TRIAL

SELF LOCKING HEAD
WET OR DRY

PATENT. PEN. 13993/55

MEIGH CASTINGS LTD.
UCKINGTON FOUNDRY, CHELTENHAM
TELEPHONE 54154.

SAFETY FIRST

THE "OLDBURY" PATENT
CARBOY DISCHARGER
will empty and elevate up to 50 feet
the contents of any carboy, bottle or
vessel, and complies with all the con-
ditions of the Factory Act of 1937.

KESTNER'S

1, Grosvenor Gardens, Westminster, London, S.W.

**For Classified Advertising
THE CHEMICAL AGE**

Gives direct and immediate penetration. Is the recognised liaison between buyer and seller. Accepts advertisements up to first post on Tuesday for insertion in that week's issue. Gives a reduced rate for more than three insertions and

PULLS IN RESULTS



with

TELCON

BERYLLIUM COPPER

TOOLS

Beryllium Copper Safety Tools, by reason of their comparatively high thermal conductivity, have little tendency to spark and can be employed with confidence in dangerous atmospheres. The great strength and hardness of these tools gives them a performance and length of life assuring their superiority in this field, and their best recommendation is their widespread use by major industrial concerns handling inflammable materials.

Distributors for Great Britain

BERYLLIUM & COPPER ALLOYS LTD

47, VICTORIA STREET, LONDON, S.W.1 ABBey 6421/2

Manufactured by

TELEGRAPH CONSTRUCTION & MAINTENANCE

TELCON WORKS • MANOR ROYAL • CRAWLEY • SUSSEX

The Chemical Age

Volume LXXIII

Number 1899

Established 1919

The Weekly Journal of Chemical Engineering and Industrial Chemistry

BOUVERIE HOUSE · 154 FLEET STREET · LONDON EC4

Telephone : FLEET STREET 3212 (26 lines) Telegrams : ALLANGAS · FLEET · LONDON

CONTENTS . 3 DECEMBER 1955

UK Chemical Exports for October	1207
SIMA Nucleonics Group	1208
Britain's Newest H ₂ SO ₄ Plant	1209
Solvic Group Expansion Scheme	1213
Flameproof Lighting Fittings	1215
Safety Notebook	1221
Lion Oil Joins Monsanto	1224
Chemist's Bookshelf	1225
Home News Items	1227
Overseas News Items	1228
Personal	1229
DSIR Invites Suggestions	1231
Company News	1232
Next Week's Events	1234
Market Reports	1236

Editor : *E. Arnold Running*

Publisher & Manager : *A. Walsby*

Director : *N. B. Livingstone Wallace*

MIDLANDS OFFICE :
Daimler House, Paradise
Street, Birmingham

Phone : Midland 0784/5

SCOTTISH OFFICE :
116, Hope Street,
Glasgow, C.2

Phone : Central 3954/5

LEEDS OFFICE :
Martins Bank Chambers,
Park Row, Leeds, 1

Phone : Leeds 22601

SINGLE COPY 1/- (BY POST 1/3)

ANNUAL SUBSCRIPTION 42/-

"Geryk" - all British

VACUUM PUMPS

FOR FACTORY OR LABORATORY PURPOSES

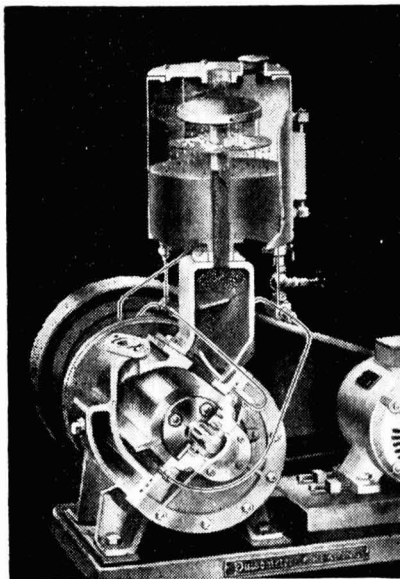

All Types and Sizes for
All Duties

Wet and Dry Pumps

Reciprocating and Rotary

**Single and Two-stage
High Vacuum Pumps**

List No. 3342

Pulsometer Engineering Co. Ltd.
Nine Elms Ironworks, Reading.

ENGLISH & FRENCH FLINT PEBBLES

IT IS A MATTER OF OPINION whether you should use English or French pebbles, but whichever is your choice we can supply you with hand-picked individually selected pebbles ranging from $\frac{1}{4}$ " to 6" in size.

They can be sent to any part of the world.

For over a century we have been noted for prompt deliveries and consistent quality and we value new enquiries.

A.L. WALLEY

FLINT WORKS,

WEST THURROCK, GRAYS, ESSEX.

Associated with ProSilex S.A. Le Treport, France.

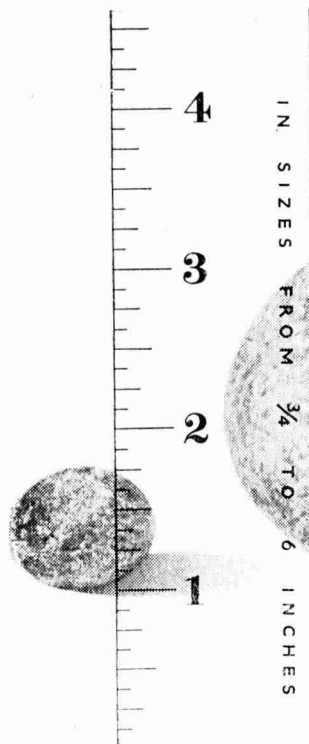

Chemicals Underfoot ?

A FEW years ago chemical conditioners for food-producing soils were hitting the headlines both in the popular and scientific Press. For the time being, at any rate, the limelight seems to have faded. The best of these products did not fail to achieve their claimed performances, but costs and difficulties of application have limited large-scale development. But this period of adulation undoubtedly obscured a totally different aspect of soil treatment with chemicals—stabilization. Soil is not only of use and importance for growing crops. It is built upon. Houses, blocks of offices, factories must be erected on it, roads and airfields must be laid on it, and often tracks for vehicles must be made out of it. Unsuitable soils must be excavated and replaced by other 'ballast' in many civil engineering projects—the labour, time, and transport needed alone cost huge sums.

If chemical treatment of existing soils could make them suitable, the saving in costs would often justify sizeable expenditure upon the chemicals required. This is a new branch of applied chemistry, born like many another development during the pressures of war. How to enable mud or shifting sand to carry the heavy paraphernalia of mechanized warfare was often a serious military problem in the 1940s. Although it cannot be claimed that chemical intervention was particularly successful despite the urgent need for 'hey presto' solutions, the

potentialities of certain chemicals as soil stabilizers began to be recognized, and research has steadily continued ever since. The subject is still in its infancy, but there are signs that the more fragile period is coming to an end.

One of the obstacles to earlier development was our general ignorance of soil science. Apart from agricultural soil science with its focus fixed upon nutrients and humus, basic research on the nature of soils had been neglected. It is only recently that clay mineralogy, soil physics and soil colloid chemistry have made inroads into a mass of complexities and variations. These have given sufficient guidance for seeking the sort of chemicals that are likely to change the physical characteristics of soils. There is a passing moral to be drawn from this. If in the course of time the chemical stabilization of soils becomes 'big business', the key that first enabled the door to be opened will have been fundamental research, mainly carried out at universities. At the same time, it must be remembered that the subject has an older empirical existence. Sun-dried earth when used as a building material by Asians, Africans, and South Americans has had its trial and error waterproofing agents—the Egyptians, for example, mixed camel dung with the dried soil. Bitumen has been extensively used to waterproof dispersed soils though it is much less effective with cohesive soils. Some of the modern silicones are

perfect waterproofers of soils, but their cost seems far too great per cubic yard of soil for any practical development.

Clay as a foundation for building work is widely recognized as one of the most difficult soils. Its compressibility is a perpetual hazard and footing loads on clay cannot be excessive without inviting settlement and cracking in the upper structure. Yet dry clay has a very high strength. A chemical agent that would produce in wet clay the properties of dry clay could transform the foundation work costs of many building and civil engineering projects. Unfortunately clays are not very permeable so that even the development of a suitable chemical additive might be beaten in practice by the difficulty of getting it to penetrate a stratum of clay to a useful depth. Successful chemical achievements seem much more likely at present in the field of aggregation, using chemicals to bind fine soil particles into larger particles. Here, of course, the scientific link between soil stabilization research and the agricultural synthetic soil conditioners is evident; US military work in this field has been much concerned with studying acrylates, also used for crop soil conditioning.

Among the aggregating chemicals are calcium and other divalent acrylates, polyacrylamide, styrene copolymers and fatty quarternary ammonium salts. Not only can these chemicals aggregate fine soils so that their strength is raised, but they enable bulkier materials that are also added to these soils for better foundation strength to be mixed into them more thoroughly. The costs of synthetic polymers may be too high for use in many civil projects, but they are not the only chemical possibilities. Salts of multi-valent metals such as aluminium sulphate, ferric chloride etc. can exert a useful compacting effect at smaller cost.

The permeability of soils to water can cause many problems in canals for irrigation or in building new reservoirs. It has been estimated that about a third of the water passing through irrigation systems is lost by seepage. Many chemicals have been tested for waterproofing dam and reservoir foundations; the creation of a durable, non-permeable or low-permeability lining brings benefits

worth a considerable cost investment. Acrylate monomer injections have been put to practical use, the polymer being formed in the soil void spaces where it acts as a water sensitive gel. An ion exchange approach has been utilized, displacing calcium cations with sodium to reduce natural soil permeability.

Certainly a parade of possibilities rather than a list of successes is all that can be described yet. Civil engineers are reluctant to experiment with chemicals. Their present practices with difficult site soils is based upon experience. Excavation and importation of more suitable base materials may be costly and cumbersome, but what can be done by these methods is fairly rigidly known. Erecting a large building on a chemically treated base obviously calls for exceptional courage and faith. Pilot scale development is not easily applicable. Nor are civil engineers and building contractors sufficiently aware that chemical solutions for some of their major problems are possibilities worth considering as future practice. The American Chemical Society made an impressive effort to bring chemists and civil engineers together earlier this year at a conference on soil stabilization by chemicals, and the recent symposium publication of most of the papers in *Industrial and Engineering Chemistry* (1955, **47**, 2230-2281) should widen its effect. It is not often that a branch of applied chemistry in so nascent a state is given encouragement of this quantity and quality.

Two major points emerged from this conference. First, although the type of chemical and chemical effects required have now been largely elucidated, the subject is still too theoretical—for most of the tasks the right chemical stabilizers have yet to be 'tailored'. Most of those so far studied are not adequate, or do not seem to be. Second, the development of potential chemical stabilizers should be aimed initially at small scale projects where the risks of experimentation will be smaller; successes in this field might then be more readily followed by trials in larger constructional work. These verdicts are perhaps disappointing in an age so accustomed to rapid chemical success, but they seem sound enough in this particular field.

Notes & Comments

New Chemical Legislation

THE long overdue revision of Regulations to the Fertilizers and Feeding Stuffs Act passed into law last month. The new regulations operate as from 1 January 1956. It is no secret that there have been many discussions between ministries, farmers, and the producing or distributing industries ever since the end of the war. The old regulations were technically obsolete as a result of progress in fertilizer technology, and the law, pending revision, had become practically a dead letter. The limits of permissible variation for compound fertilizer statements of nutrient content were too narrow for modern, high-analysis mixtures—the degree of ‘error’ allowed was much too small proportionately, however fair it may have been back in the 1920s and 1930s when a 7 per cent declaration was considered high. Such ‘new’ fertilizers as ‘Nitro-Chalk’, triple superphosphate, dicalcium phosphate, were not included in the old schedule—now, of course, they have been brought in. There was no guidance as to methods of sampling liquid fertilizers—which are now used intensively in glasshouse cropping—and this omission has been rectified.

A Major Change

AS more than 60 per cent of our fertilizer usage is in compound form, the alterations in limits of variation for this type of product must be regarded as the major change. Formerly the permissible variation for each nutrient declaration was 0.5 per cent except for nitrogen and potash declarations not over 4 per cent, when the limit allowed was only 0.3 per cent, or for the same nutrients declared at over 5 per cent, when 0.75 per cent was allowed. Now, for all nutrients, the variation allowed is 0.5 per cent where the declared amount is not over 5 per cent. For declared amounts of over 5 and up to 8 per cent, the variation becomes 0.75 per cent; and for declared amounts over 8 per cent, one-eighth of the stated amount or one-tenth is allowed accord-

ing to whether the quantity sampled is one ton or less, or more than one ton. Also, there is an over-all limit—the total sum of variations from nutrient declarations in a compound must not exceed 1.75 per cent.

Limits of Variation

BUYERS of compounds may suppose that manufacturers have been given more ‘elbow-room’, and they may feel that this is paradoxical in an age of increasing scientific control. Buyers must realize that the modern compound is a far more concentrated product, commonly containing twice or three times as much total nutrient value as lower-grade compounds of 20 and 25 years ago. Nothing spotlights this more than the former dividing lines for changes in limitations for nitrogen and potash statements—under 4 per cent or over 5 per cent! Today nitrogen contents commonly range between 7 and 12 per cent and potash declarations of 10 to 15 per cent are frequent. It is absolutely right for variations in contents above 8 per cent to take the form of proportions instead of fixed amounts; to have done otherwise would have cast an important piece of technico-legislation into final disrepute. The over-all limitation is a sufficient safeguard to the buyer should any manufacturer attempt to work ‘to a minimum’. It should also be realized that limits of variation do not cover processing deviations alone—they also cover the inevitable degrees of inaccuracy in sampling and analysis. Surveys have shown that these ‘extra-manufacture’ deviations are not nearly as small as usually supposed.

By Any Other Name

THE growth of industrial organic chemistry both in size and complexity has produced a host of problems of nomenclature. Not often is the correct scientific name of a synthetic substance suitable for commercial or popular use. Obvious examples of this are to be found by the dozen in the modern insecticides and plastics indus-

tries. Also, of course, when one of these new products has been developed by a manufacturing company, a coined name is a useful part of proprietary rights as well as being convenient. It is probably true to say that industrial chemistry in the past 10 years has been responsible for more additions of words to man's vocabulary than any other influence—nylon, lindane, aldrin, cortisone etc. That indefatigable authority on scientific names, Austin Patterson of *Chemical & Engineering News*, has been discussing this problem of name coinage recently (1955, 45, 4805), and has set out a few 'rules'.

Short & Easy

A NEW common name should be short and easy to pronounce. Such names should not resemble systematic names of chemistry too closely or a risk of confusion is introduced (an old example of this is the common name, 'superphosphate', coined more than a century ago, often most misleading to young scientists who come across it for the first time). If a suffix used for proper chemical nomenclature is used in a coined name, it should carry its genuine meaning; and on this point Mr. Patterson suggests very sensibly that there are plenty of suffixes without chemical meaning that coiners of names

might use e.g., -ac, -em, -ot. When a substance can function in the form of various salts the coined name should apply to the parent substance or radical and not to any particular salt; the antibiotic and selective weedkiller fields provide examples of this, and in general the rule would seem to be followed. No newly coined name should have a close resemblance in spelling or pronunciation with an existing scientific or common name. Should common names be made by abbreviating scientific names? This frequent device is sometimes criticized; Mr. Patterson suggests that it is not objectionable so long as there is no risk of confusion, and we are inclined to agree with this view.

Short Names Needed

IT is a valuable service to international science to focus attention upon this problem. Putting forward some tentative rules or principles should lead to constructive discussion. There can be no question that short common names are needed for every new chemical substance with a long scientific name and any commercial prospects. The recent question in the House of Commons which involved a lengthy chemical name showed that true scientific names are best kept for use in scientific circles.

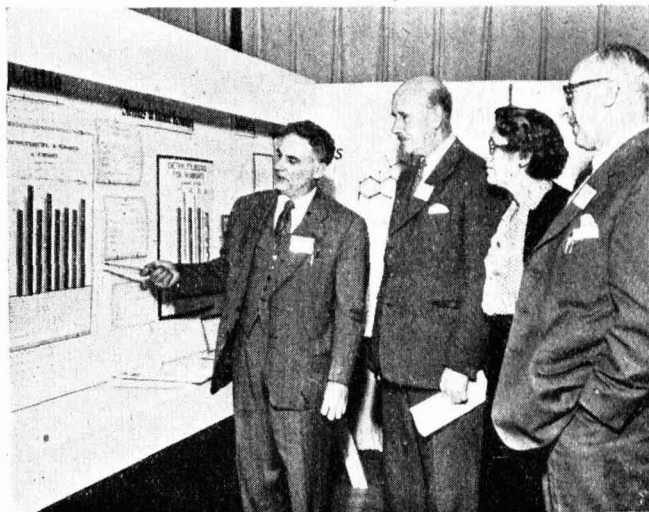

Three British delegates to the recent First International Conference on the Uses of Antibiotics in Agriculture, organized by Charles Pfizer & Co. Inc., are shown here at the Pfizer 700-acre experimental farm in Indiana. They are: Dr. W. S. Gordon of the Agricultural Research Council Research Station, Compton, Dr. Margaret Wright of the Walton Oaks Research Centre and Dr. J. Duckworth of the Rowett Research Institute. Pointing at the wall diagram is Mr. Donald Chichester of the Pfizer organization

Chemical Exports for October

America Becomes a Principal Buyer

THE value of British chemicals exported during October showed a small gain over the preceding month. Australia was still the chief importer, although the value of her imports was down by £373,719 from the September total which exceeded £2,000,000. Indian and South African imports also decreased slightly during the month. A notable feature was the increased demand from Argentina.

Demand for most chemicals was steady during the month, although there was a marked decrease in the value of fertilizer exports which fell from £535,171 in September to £234,733. Ammonium sulphate exports declined from the previous month by about one-third, a trend that appears to be continuing, for in October last year exports were more than four times greater. There was a marked demand for creosote oil which rose to 3,519,125 gallons, three times the total of gallons exported in September. By far the biggest importer of British fertilizers in October was Jamaica; £38,342 of the £207,532 spent during the month being for fertilizers.

Total for elements & compounds in £s		£4,634,650	£4,694,381	£4,122,457
Coal tar (tons)	..	6,584	13,450	14,014
Cresylic acid (gal.)	..	223,313	244,732	221,918
Creosote oil (gal.)	..	3,519,125	1,184,730	1,639,124
Total for tar products in £s		£410,796	£309,170	£354,629
Indigo, synthetic (cwt.)	..	3,648	2,805	3,351
Total for synthetic dyestuffs (cwt.)		22,191	18,167	18,745
Total for paints, pigments & tannins in £s		£2,042,015	£1,955,594	£1,346,727
Total for medicinal & pharmaceutical products in £s		£3,203,070	£3,053,274	£2,623,066
Total for essential oils, perfumes, etc. in £s		£2,297,858	£2,420,088	£1,476,939
Ammonium nitrate (tons)	..	546	847	439
Ammonium sulphate (tons)	..	9,652	24,172	38,730
Total for all fertilizers in £s		£234,733	£535,171	£752,563
Total for plastics materials (cwt.)		454,490	143,646	125,476
Disinfectants etc. (cwt.)	..	17,422	15,294	14,225
Insecticides, fungicides (cwt.)	..	38,696	52,881	27,631
Rodenticides & weed-killers (cwt.)	..	2,131	2,753	4,729
Lead tetra-ethyl (gal.)	..	502,370	342,658	475,336
VALUE OF EXPORTS IN £s: PRINCIPAL BUYERS OF CHEMICALS				
		Oct. 1955	Sept. 1955	Oct. 1954
Australia	..	1,747,950	2,121,669	1,421,937
India	..	1,501,807	1,628,320	1,251,591
South Africa	..	971,358	1,048,040	733,206
Canada	..	857,831	656,761	535,728
New Zealand	..	707,667	918,890	577,131
United States	..	679,011	679,247	582,722
Netherlands	..	654,058	685,011	547,272
Eire	..	570,782	478,617	537,883
Nigeria	..	533,817	504,496	307,632
Sweden	..	543,990	508,323	567,371
Italy	..	535,071	481,439	321,955
Western Germany	..	516,905	462,270	309,178
France	..	512,118	402,654	537,417
Argentina	..	478,540	198,022	761,088
Pakistan	..	414,664	294,256	338,940
Belgium	..	405,327	481,439	293,419
Gold Coast	..	361,965	356,153	344,073
Denmark	..	358,331	316,518	352,845
Total value of chemical exports		20,589,416	20,383,688	16,878,353

EXPORTS: PRINCIPAL COMMODITIES

	Oct. 1955	Sept. 1955	Oct. 1954
Acids, inorganic (cwt.)	18,599	17,678	13,445
Copper sulphate (tons)	2,166	1,956	1,412
Sodium hydroxide (cwt.)	300,189	358,986	321,174
Sodium carbonate (cwt.)	492,478	421,967	454,805
Aluminium oxide (tons)	1,015	1,009	117
Aluminium sulphate (tons)	4,327	4,669	4,098
Ammonia (cwt.)	8,385	11,554	9,892
Bismuth compounds (lb.)	25,279	22,406	33,455
Bleaching powder (cwt.)	32,206	29,162	18,481
Hydrosulphite	11,468	11,378	9,495
Calcium compounds, inorganic (cwt.)	32,037	44,696	23,834
Lead compounds, inorganic (cwt.)	6,261	5,362	5,486
Magnesium compounds (tons)	1,931	2,593	658
Nickel salts (cwt.)	5,650	7,394	9,231
Potassium compounds (cwt.)	5,638	6,221	3,384
Acids, organic & derivatives (value in £s)	92,053	73,227	81,871
Ethyl, methyl etc. alcohols (value in £s)	127,753	158,010	96,428
Acetone (cwt.)	9,360	10,381	10,240
Citric acid (cwt.)	2,087	2,385	2,730
Sulphonamides, unprepared (lb.)	78,782	143,383	66,084
Dyestuffs intermediates (cwt.)	5,730	8,286	5,258

Nucleonics Group

Members of SIMA Consolidated

AS more than half of its 140 member firms are engaged in manufacturing electronic, mechanical or optical instruments and equipment for atomic energy applications, the Scientific Instrument Manufacturers' Association has consolidated a permanent nucleonics group. At a meeting on 18 November, the group elected Mr. R. Y. Parry of Ekco Electronics Ltd. as its chairman, and Mr. H. A. Luss of Isotope Developments Ltd. as vice-chairman.

At the same meeting, Dr. Denis Taylor, Ph.D., F.Inst.P., of the United Kingdom Atomic Energy Authority, said that the Atomic Energy Authority welcomed SIMA's move in setting up a nucleonics group. SIMA has been active in the field of atomic energy, nucleonics and radio-isotopes for a considerable time and has acted, at the suggestion of the Atomic Energy Research Establishment, Harwell, as a liaison body for more than 100 equipment manufacturers. Five years ago SIMA produced the first edition of the radio-isotope handbook.

Earlier this year SIMA organized a group participation of some of its member firms in the Atoms for Peace Exhibition in Geneva, and is now arranging, in conjunction with the Board of Trade, a similar participation in the forthcoming Atomic Exposition in Cleveland, Ohio. To demonstrate the importance of applications of atomic energy to a wider field in this country, it is organizing an atoms, electrons and industry exhibition to be held in Bristol from 6 to 8 June next year.

GEC Atomic Group

THE GEC-Simon Carves Industrial Atomic Energy Group have come to an arrangement under which Motherwell Bridge & Engineering Co. Ltd. will be associated with them in the construction of nuclear power stations.

The works of The Motherwell Bridge & Engineering Co. Ltd. cover 35 acres and have a shop floor area of 410,000 sq. ft. With the exception of shipbuilders, the company is the largest buyer of steel plates in Britain. It has recently installed what is said to be one of the largest stress relieving furnaces of its kind in the country and a pickling plant which contains the most modern equipment.

Associated with the development of its pressure vessel shops the company has built modern laboratories for carrying out X-ray development and viewing, and mechanical and metallurgical testing covering all the modern methods of steel process control. As part of its current £1,000,000 works extension and re-equipment scheme, it is installing a 2,000-ton hydraulic press for special plate work to supplement its existing 1,000-ton press.

The company is closely associated with The Chicago Bridge & Iron Co. of America and a free interchange of technical developments and research takes place between the two companies. It is the sole licensee for Hortonspheres and is at present constructing the 140 ft. dia. sphere for the UK Atomic Energy Authority's experimental fast reactor at Dounreay, Caithness.

Polarography

New Cambridge Laboratory Opened

A SPECIAL polarographic research laboratory was opened on 16 November by Professor J. Heyrovsky of the Central Polarographic Institute of Czechoslovakia. This new laboratory has been built by the Cambridge Instrument Co. Ltd. and is adjacent to their Cambridge works.

The opening ceremony was under the chairmanship of Sir J. A. N. Barlow and the new laboratory will be in the charge of Mr. W. J. Parker.

There is still an unsatisfied demand for chemists skilled in the operation of modern scientific apparatus and in the interpretation of data, say the company, and this is no less true in the highly specialized field of polarography.

The research department of the company has done a large amount of work on the development of polarographic instruments and techniques and has always endeavoured to help users of polarographs in the solution of their own particular problems. The volume of this work has increased so much, say the company, that it has not been possible to give the immediate service that is desirable with such problems and it is for this reason that this new laboratory has been opened.

The Central Polarographic Institute of Czechoslovakia was founded in Prague by Professor Heyrovsky who invented the polarograph in 1925.

Britain's Newest Sulphuric Acid Plant

Solway Chemicals Invade London Market

Britain's newest sulphuric acid plant, owned by Solway Chemicals Ltd. and located at Whitehaven, Cumberland, was visited by The Duke of Edinburgh on Thursday of last week. The plant, which has only been in operation for a few months, uses anhydrite from mines on the site and the Duke surprised everyone by asking to be taken down to the mine face. As a result of the Duke of Edinburgh's inspection, and a well-organized tour by journalists representing trade, technical, national and local newspapers, the Solway Chemicals plant obtained an exceptionally 'good Press'.

The Whitehaven plant was built to an overall design supplied by Farbenfabriken Bayer AG, Leversuken, based on the Müller-Khüne process, and Solway had the benefit of advice and assistance from Dr. H. H. Khüne, one of the originators of the process. The rated capacity of the plant is 100,000 tons of sulphuric acid per year with 100,000 tons of cement as a by-product.

Although sulphuric acid at the moment is something of a drug on the market (less than 75 per cent of present plant capacity being used) Mr. Frank Schon, chairman of Solway, was far from pessimistic about the future when welcoming journalists. Although he frankly admitted that storage tanks were

full at the moment he pointed to the steady increase in consumption which has taken place in recent years and added that it was not impossible that the capacity of the plant would one day be doubled. Provision for such an extension has been made in the layout of the site.

Total acid production capacity in this country has increased by over 40 per cent since 1951, and less than one-third of the total UK output of H_2SO_4 to-day is derived from elemental sulphur compared with one-half only four years ago. Mr. Schon told *THE CHEMICAL AGE* that the new Solway plant could produce acid as cheaply as any anhydrite plant in the United Kingdom and more cheaply than any of those burning pyrites. He expressed the opinion that someday most of Britain's sulphuric acid would be produced from anhydrite.

There is a saying to the effect that luck comes to the deserving and the history of Solway Chemicals and the parent concern, Marchon Products Ltd. (which at the moment is being acquired by Albright & Wilson) is proof of this.

From very humble beginnings Marchon Products grew by leaps and bounds between the years 1939-1950 and became a large consumer of sulphuric acid. In view of its



A general view of Solway Chemicals Ltd., Whitehaven

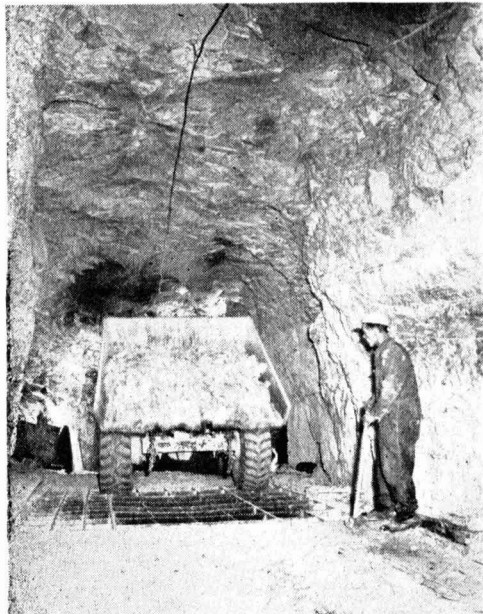

Anhydrite being dumped into a hopper in the mine for conveying to the surface

isolated position it had to pay heavy freight charges on its acid and so it was decided to build a plant of its own. A proposal for the erection of a pyrites plant was turned down by the Board of Trade and it was only then that it was discovered that the Marchon site was directly above one of the largest seams of anhydrite in the British Isles.

It is estimated that the deposits are sufficient to last for approximately 100 years and the quality of the rock and its accessibility are excellent. Shale is quarried only a stone's throw from the kilns, and coal is also available from near-by mines. Equally important, there is a local market for the by-product cement.

The only drawback to the Solway set-up is that sulphuric acid is a low-priced commodity and high freight rates can often be crippling unless a market can be found nearby. One half of the new plant's output is used at the Marchon Products plants which are only a few hundred yards away, but this still leaves approximately 50,000 tons of acid a year to dispose of. Unfortunately Cumberland cannot yet absorb any great quantity of this acid. Large quantities are therefore being offered for sale in areas which already have their own sources of supplies and train-load shipments are even being

offered to the London market. On such large quantities the freight charges are reasonable and the price of the acid from Whitehaven can be, and is, competitive in London.

Replying to a question from THE CHEMICAL AGE, Mr. Schon stated that he did not agree with the view that the current prices for sulphuric acid in Britain were too high. He admitted that the older sulphur burning plants had a great advantage in that their original cost had long ago been written off. But, he said, the production of sulphuric acid was of great national importance and at the time of the sulphur crisis the industry had been encouraged to expand output capacity by building plants which did not need Frasch sulphur. The pyrites burning plants were under a disadvantage owing to the present high cost of their raw material and this had to be taken into consideration when studying the price of sulphuric acid. When one compared British prices with the prices in foreign countries he did not believe that users of acid in this country were paying too much.

London Manufacturers Interested

Great interest in the scheme is being shown by other sulphuric acid manufacturers. In London on Tuesday a leading manufacturer told THE CHEMICAL AGE that the transportation of sulphuric acid over great distances by rail raised problems of continuity of supply. Delays caused by bad weather or railway strikes would seriously inconvenience users, most of whom had not the capacity for storing sufficient quantities of acid to guard against these contingencies. The problem of obtaining sufficient rolling stock was thought to be considerable as the number of trucks required for such a scheme would have to include those returning empty. It was also pointed out that another drawback to the scheme was the possibility of strong sulphuric acid freezing while being transported in cold weather.

The anhydrite mine at Whitehaven is some 300 ft. below ground and is reached by two 1,000 yard long drifts with a slope of one in seven. The mining is done by the very latest methods and a minimum of labour is involved. Approximately 70-80 tons of rock are brought down by each blast and this is loaded by electric shovels on to diesel dumpers. These tip their loads into a hopper in the centre of the mine, from

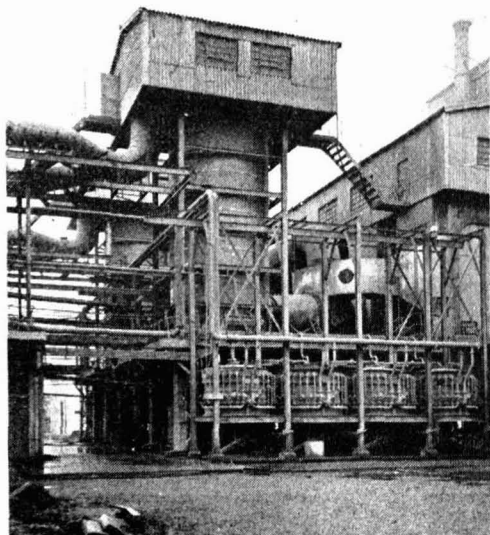

Gas cleaning and cooling

which the rock is carried by means of conveyor belts to the screening and crushing works on the surface. An average output of 350,000 tons of anhydrite a year is expected without working more than one shift a day. This is double the original estimate and the surplus is being sold for the manufacture of sulphate of ammonia.

The anhydrite leaves the screening and crushing plant in pieces of approximately $\frac{1}{4}$ in. size and is fed to the raw material silos from which it is weighed out on to a belt and fed, together with the correct proportions of shale and coke, to a ball mill. Here the mixture is ground to a fine powder and pumped to the raw meal silos where it is

analysed. If not suitable the blend is adjusted. The mixture is very roughly 80 per cent anhydrite, $13\frac{1}{2}$ per cent shale and $6\frac{1}{2}$ per cent coke.

After being mixed with 10 per cent water in a nodulizing system to cut down dust, the mixture is fed into two great kilns supplied by Edgar Allen & Co. Ltd. These kilns are each 230 ft. in length and have a diameter of 11 ft. 2 in. One kiln consumes 28 cwt. of coal per hour but the other, at the moment, is being fired by oil. The kilns are lined to withstand temperature of $1,600^{\circ}\text{C}$ although the operating temperature is $1,400^{\circ}\text{C}$.

The gases leaving the cold end of the kilns contain approximately $8\frac{1}{2}$ to 9 per cent sulphur dioxide. They are filtered, cooled and dried by conventional methods before being passed on to the sulphuric acid plant.

The acid is made by the contact system, the gas streams from the electro-precipitators passing through a drying tower in which water is removed by counter-current circulation of concentrated sulphuric acid. The dried gas then passes through blowers into converters containing the vanadium catalyst. The sulphur trioxide is then passed to the absorber towers where it is absorbed into circulating sulphuric acid which is kept at a constant strength by the controlled addition of water. The plant is also equipped to produce oleum.

A section of the plant worthy of special mention is the group of 14 acid coolers which were manufactured by Mills Packard Construction Co. Ltd. at their Ipswich works from lead supplied by British Lead Mills Ltd. They were transported as complete units by road to Whitehaven.

Each cooler unit weighs seven tons, is con-

Heat exchangers and converters. Much of this section was built by W. J. Fraser, Ltd.

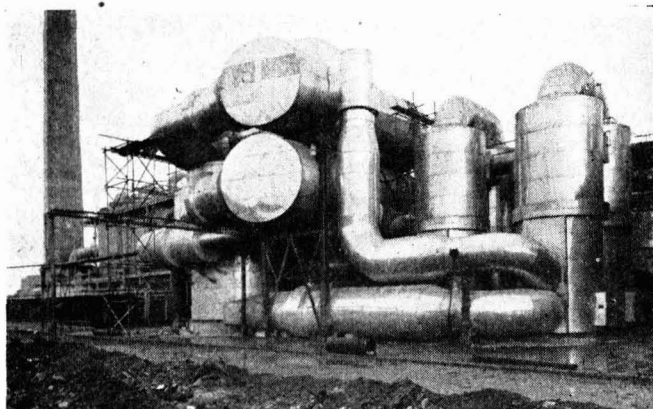

Another part of the gas cleaning and cooling department at Whitehaven

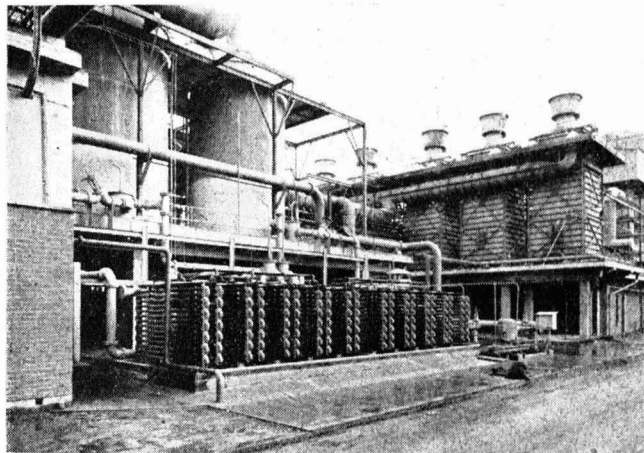

structed almost entirely from lead (with the exception of a supporting framework of steel) involving 1,200 ft. of lead welds and incorporating 1,500 ft. of cooling water pipes.

After arrival on site the coolers were handled by mobile crane on to supporting structures and very readily connected to water and acid mains, drains, etc., thus showing once again how large pre-fabricated constructions, made possible by careful planning and transport, can help to reduce time required for site work and overall fabrication costs which are at their lowest in the well organized works.

The electrical installations at Whitehaven were handled by Crompton Parkinson. Maximum electrical power will be in the region of 3,750 kw, unit usage being 20,000,000 per year. Six main substations form part of the ring main system and are positioned at the main concentrations of load. A 3.3 kv supply for the grinding mill motors, which are of 850 HP rating, is in contrast to the 440 v supplies standardized for practically all other equipment.

Because of the possible effects of acid fumes in the atmosphere all outdoor transformers are hermetically sealed—distinct from the more usual practice of providing them with conservators. They have also been coated with a sulphuric acid resisting paint.

Only two standard sizes were used—750 kVE for the 3.3 kv supplies and 1,000 kVA for the 440 v supplies—so facilitating interchangeability. Switchgear, all of which is housed in standard brick and concrete buildings, has also been standardized. Electro tinning of copper busbars and connections

was made standard procedure, but where the bare copper could not be tinned it was coated with an anti-acid varnish. All cable installations incorporate specially designed anti-corrosive covering to protect the armour and lead sheathing from possible acid seepage.

Ancorite acid proof brick linings (as supplied by Ancorite Ltd.) were used in all reactors, absorption towers, drying towers, hairpin coolers and circulation tanks at the Solway plant.

The clinker is discharged from the hot end of the kiln at the rate of approximately 140 tons per day. It is cooled before storage and after ageing for some time is crushed, ground and finally milled. It is automatically bagged ready for despatch.

In the cement packing plant, 'Daylor' combined automatic packing and weighing machines are used together with 'Daylor' automatic dust collectors, vibrating screens and ancillary plant. This equipment was supplied by J. Darnley Taylor Ltd.

To Meet Electronic Needs

A. M. Lock & Co. Ltd., electronic engineers, of Chadderton, Oldham, are extending their organization. Their works and service department now occupy the whole of the premises in Crompton Street, Chadderton, and new offices have been opened at Prudential Buildings, 79 Union Street, Oldham, to accommodate the sales and accounts division. Northern agents for a number of leading manufacturers of electric and nucleonic equipment Lock's will establish a sales and service department in Birmingham.

Expansion Scheme

Solvic Develop PVC Production

VARIOUS grades of pvc obtained by the emulsion and suspension processes, and vinyl chloride/vinyl acetate copolymers and pvc compounds are manufactured by the Solvic Group in which Imperial Chemical Industries Ltd. has an important financial interest. Solvic's first factory did not go into production until 1949 but by 1957 their total capacity is expected to be 55,000 tons per year.

Belgian Factory Expanded

The Belgian factory at Jemeppe-sur-Sambre has been expanded and new factories have been built in France, Italy, Austria, Spain and Brazil.

Work on the construction of new buildings for SA Solvic, Brussels, which started in April of this year, is said to be progressing rapidly and it is expected that the plant will go into production during the second half of 1956. The capacity for producing pvc and copolymers will be increased to 15,000 tons per year.

The Tavaux (Jura) factory of the Societé Solvic of Paris has decided to increase its annual capacity to 24,000 tons. This expansion should make it possible to meet the growing demands of the French market.

At the beginning of the year the capacity of the Ferrara factory of SA Solvic, Milan, was raised to 9,000 tons.

Halvic, a sister company of SA Solvic, Brussels, went into production at its Hallein, Austria, pvc plant during the second half of 1953. The initial capacity was found to be inadequate to meet the demands of the Austrian market and it was decided to extend the plant progressively in order to raise the capacity to 3,600 tons per year as soon as possible.

New Factory in Spain

A new factory is now under construction at Torrelavega in Spain. The scheduled initial capacity of this factory is 2,000 tons per year and it should go into production during the first quarter of 1956.

The Solvic process is used by the Societé Elclor in Brazil, who are now completing the construction of their pvc plant which will have a capacity of 2,000 tons per year. Plans have already been made for raising the capacity of this factory to 4,000 tons per year.

UK Oil Consumption Rises

OIL consumption in the United Kingdom rose by 11 per cent in the first nine months of this year as compared with the same period in 1954, reports the Petroleum Information Bureau. Total deliveries of petroleum products reached 17,235,018 tons (excluding bunkers for ships in the foreign trade) as against 15,526,344 tons last year.

Interesting trends revealed by the report were the increased demands for fuel oil, Derv fuel, and gas/Diesel oil this year. The use of fuel oil as a source of industrial energy in place of coal was no doubt responsible for a rise of 21 per cent to 3,812,140 tons, as against 3,140,457 tons in the corresponding period last year.

The use of gas oil by the Gas Board, in order to enrich town gas, was partly responsible for the 12 per cent rise in deliveries which reached 1,580,138 tons, compared with 1,407,714 tons, although the PIB report suggests the increase also reflects the growing preference for diesel tractors in place of those utilizing vaporizing oil. Vaporizing oil was the only product to decline in use.

Restrictions Lifted

NORTH American Cyanamid, the Canadian subsidiary of American Cyanamid Co., is now marketing a wide range of heavy chemicals for industrial use in Canada. Chemicals produced by Cyanamid's two large plants in Niagara Falls, Ontario, include ammonia, ammonium nitrate, calcium carbide and sulphuric acid, all previously restricted for use in the agricultural fertilizer industry. These chemicals are now being marketed subject only to production capacities.

'Canada's rapid industrial growth to maturity and subsequent demand for chemicals has led us to expand into the plastics, pulp and paper, paint, dyes and metallurgical industries,' said Mr. F. S. Washburn, the president of North American Cyanamid.

The company will, however, continue to produce agricultural fertilizers which it has done since it was formed in 1907. Cyanamid will also offer its wide range of other industrial chemicals, plastics and resins, mining chemicals, dyestuffs and pigments, textile resins, paper chemicals, pharmaceutical products and agricultural chemicals, some of which are processed in the US by associate firms.

Nuclear Energy Committee

Foundation by Institute of Metals

THE COUNCIL of the Institute of Metals has appointed a Nuclear Energy Committee with the object of stimulating interest in metallurgical problems arising in connection with the industrial and scientific aspects of the use of nuclear energy.

It is proposed that, among its activities, the new committee shall arrange special meetings, discussions and symposia; invite the writing of papers or articles for publication; and arrange the publication of books or other literature to attain the objects for which it was formed.

The committee hopes to arrange an exhibition of nuclear energy products, of interest to metallurgists, in connection with the institute's spring meeting in April 1956.

The constitution of the committee is: Mr. G. L. Bailey (British Non-Ferrous Metals Research Association); Mr. E. W. Colbeck (Hadfield Ltd.); Dr. Maurice Cook (Imperial Chemical Industries Ltd., Metals Division); Dr. S. F. Dorey (Lloyd's Register of Shipping); Dr. H. M. Finniston (UK Atomic Energy Authority); Dr. Ivor Jenkins (The General Electric Co. Ltd.); Professor A. G. Quarrell (University of Sheffield); Mr. L. Rotherham (UK Atomic Energy Authority); Mr. S. S. Smith (Imperial Chemical Industries Ltd., Metals Division); and Major P. L. Teed (Vickers-Armstrongs (Aircraft) Ltd.).

Persons interested in the activities of the committee should communicate with Lt.-Col. S. C. Guilan, secretary, The Institute of Metals, 4 Grosvenor Gardens, London SW1.

Canadian Atomic Scheme

Privately-Owned Reactor Planned

THE FIRST privately-owned atomic energy reactor in Canada may be operating in two years. About 12 Canadian firms in the rubber, oil, chemical and other industries are being invited by the Pulp and Paper Research Institute, Montreal, and Isotope Products Ltd., Oakville, to join in a study of a \$1,000,000 to \$2,000,000 scheme to build a reactor for their specific industrial purposes.

Several firms have already agreed to come in and the decision of others is expected within the next week or two. The sponsors

believe they can go ahead with their plan if six to eight firms support it. They estimate the study would take about nine months and that the reactor could be built and operating by late 1957 or early 1958.

The companies would share the cost and jointly own the reactor which would be operated by Isotope Products for research purposes and for manufacturing, where possible, isotopes for the firms involved.

The sponsors hope to get the full co-operation of the Federal Government and Atomic Energy of Canada Ltd. for the project but an official approach has been postponed until the private firms have lined up. It is emphasized that the reactor would not conflict with work now being carried out at Chalk River.

A tentative development programme which has been drawn up states that the primary object of each participating company would be a plan of research development and test work designed to benefit their operation. To achieve this, each company would name one or more technical liaison representatives to co-ordinate their interests.

Isotope Products will set up a research project task force of senior scientists to study the problems of each participating company and to work with their representatives. It will also ensure that the facilities provided meet the requirements of each programme.

Olin Mathieson for UK

Although no official confirmation has yet been received, we are most reliably informed that the Olin Mathieson Chemical Corporation is about to establish a British subsidiary. The firm is one of America's most diversified processing and manufacturing enterprises with net sales in 1954 amounting to \$470,108,000. It operates 45 plants in the US and 17 abroad and produces industrial and agricultural chemicals, petrochemicals, pharmaceuticals, medicinal chemicals, cellophane, polythene film, industrial explosives, non-ferrous alloys, sporting ammunition etc. One of its divisions, E. R. Squibb & Sons Ltd., is already established in this country as manufacturing chemists. It is said that the board of directors will consist of prominent British businessmen as well as representatives from the parent company in the US but so far there are no signs as to what fields the new company will engage in.

Flameproof Lighting Fittings

by A. G. THOMSON

THE growing use of hazardous materials in manufacturing processes has stimulated the development of safe electrical equipment to overcome the danger of explosion or fire in atmospheres where an inflammable gas, liquid or dust is present.

A lighting system for use in a hazardous atmosphere must be so designed that every precaution is taken to guard against the possibility of explosion or fire being caused by accelerated sparking or damage to the equipment. Apparatus certified by the Ministry of Fuel and Power as 'flameproof', 'intrinsically safe' or 'approved' must be installed throughout the danger building or in certain specific areas, depending on the nature and extent of the hazard.

A flameproof enclosure for electrical apparatus is defined by BS 229:1947 as 'one that will withstand without injury any explosion of the prescribed inflammable gas that may occur within it under practical conditions of operation within the rating of the apparatus (and recognised overloads, if any associated therewith) and will prevent the transmission of flame such as will ignite the prescribed inflammable gas which may be present in the surrounding atmosphere'.

In the early days of flameproof enclosures the aim of the designer was to reduce the internal pressure set up by an explosion within the housing itself, such devices as simple safety valves being employed. Present practice, however, is to design an enclosure having specified minimum flange and joint clearances.

Intrinsically Safe

The term 'intrinsically safe' is defined in BS 1259:1945. Applied to a circuit, it denotes that any sparking that may occur therein in normal working and with the prescribed components is incapable of causing an explosion of the prescribed inflammable gas or vapour. Applied to apparatus, the term denotes that it is so constructed that when connected and used under the prescribed conditions any sparking that may occur in normal working, either in the apparatus or in the circuit associated therewith, is incapable of causing an explosion of the prescribed inflammable gas or vapour.

This group of apparatus is relatively small and is composed mainly of such items as bells, relays and telephones, as well as one or two small transformers which can be used for lighting small lamps.

It is noteworthy that no lamp of any size operated by a heated filament can be termed intrinsically safe, since the incandescent filament will always ignite gas. In small lamps of the intrinsically safe circuit type, the required protection is derived from the fact that the leads from the transformer are always safe even if short-circuited, while the lamp itself is enclosed in a strong—but not necessarily flameproof—housing.

Approved Apparatus

Apparatus which is neither flameproof nor intrinsically safe may be approved by the authorities concerned as being safe for use in the specific industrial hazard and the conditions covered by the terms of the certificate. This class of equipment is known as 'Approved Apparatus'. It is very limited and generally comprises certain handlamps and similar apparatus where the volume of the enclosure is small.

Though the use of portable lamps in hazardous situations has not been favoured by the factory department or the testing authorities, it is appreciated that there are occasions when no other source of illumination is possible. Portable lamps can be dangerous for two reasons. In the first place, there is the possibility that the handle might become live and that a spark from it might touch an earthed metallic body and ignite any explosive mixture present. Secondly, the flexibility of the connecting cable is usually obtained by sacrificing the thickness of insulating cover or armouring, or both. Since the cables of portable lamps are liable to be trodden on and run over by trucks, they present a potential hazard, which can be minimized by using a low voltage.

Yet there is a need for portable lighting equipment which is efficient and safe in explosive atmospheres. Many of the newer processes involve continuous production throughout the twenty-four hours in areas which are potentially dangerous. It is essential that the men working in such conditions

Industrial Safety

should have available a safe and constant source of light, especially in the event of a mains breakdown. Constant research, much of it in connection with the mining industry, has led to the development of lamps for use in chemical plants, oil refineries, plastics factories, etc., which provide maximum safety.

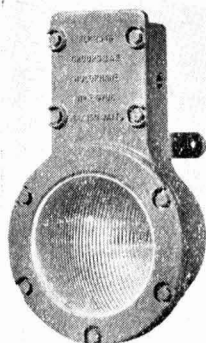

Holophane bulkhead flameproof unit No. F.9796 Buxton certified for use with inflammable gas in Groups 2 and 3. Designed for use with 60 - 100 - 150 watt GLS lamps

One type of lamp provides security while in use by means of a magnetic lock over the charging contacts and sealed locks on the lens ring and lamp top. It gives a high intensity light for over eight hours without recharging. A British manufacturer has developed the only electric cap lamp to be passed as safe for use in atmospheres containing hydrogen, since the test regulations were revised in the light of more up-to-date knowledge of intrinsic safety. Electric torches approved by HM Inspector of Factories and the Ministry of Fuel and Power can also be obtained.

Hazardous atmospheres in buildings may

be divided broadly into two main categories: those in which gases, vapours or volatile liquids are present and may form an explosive mixture with air, either at room temperature or at some higher temperature, and those in which an explosive mixture may be formed by combustible dusts in air.

When dealing with gases alone by far the safest practice is to provide sufficient air change to ensure that the gas concentration is always kept below the ignitable or explosive limit. In most cases there is a maximum and minimum concentration of a gas in air above and below which it cannot maintain combustion. These are known as the explosive limits. The lowest temperature at which combustion can occur is termed the ignition temperature and varies with different vapour and air mixtures.

Much research has been carried out on the dangers from gas explosion. Inflammable gases and vapours have been divided into four main groups, the classification being based on the permissible gap dimensions of the flameproof enclosure in relation to the particular hazard. Three of these groups are as follows:

Group 1—Methane (firedamp).

Group 2—A large number of petrols, alcohols and cellulose solvents.

Group 3—Coal gas and coke-oven gas.

The fourth group specifies acetylene, carbon disulphide, hydrogen and other gases for which no electrical apparatus is permitted, owing to the fact that the maximum safe gap or tolerance between the machined joint covers is too small to be practicable. The hazards presented by this group may be avoided by projecting light through armour plate glass panels from sources located outside the building. A high degree of protection is also afforded by the

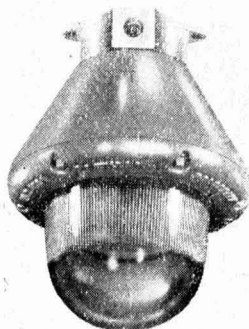

Holophane flameproof unit No. F.9821 for ceiling mounting. Lamp wattage 100-150 GLS Buxton certified under Class B (industrial type) for use in Groups 2 and 3 gases in the petroleum industry, cellulose plant, coal handling and treatment equipment areas and in a wide range of hazardous chemical processes. The body is of aluminium-silicon alloy casting, the front glass is a specially treated prismatic lens, and the reflector is an accurately moulded prismatic glass reflector arranged for close mounting to the lamp

Industrial Safety

use of a pressurization system in which air or a neutral gas is present in the fitting at all times when the hazard is present. Provision is made in the controls for interruption of the electrical supply should a case of fitting fracture occur.

Reference should be made to the official documents for a complete list of the vapours and gases included under the various headings.

In the case of liquids the precautions to be taken will depend on such factors as the flash point and the room or process temperature. BS 229 states that 'the flash point of a liquid is an arbitrary ignition temperature of its saturated vapour and may be regarded as a rough index of the liability of the liquid to form explosive mixtures with air and, therefore, as a measure of the risk of explosion where it is used in industrial processes'. In America the flash point is described more briefly as the temperature below which a liquid will not assume the vapour state in a dangerous quantity. Since the tendency to evaporate becomes greater with increases in temperature, it is evident that even a very small rise in room temperature might transform quite a safe liquid into one that is potentially dangerous. In general, the use of flameproof equipment would be desirable in situations where there was a possibility that the flash point of a liquid might be exceeded by the ambient or process temperature.

Some industrial dusts are potentially as dangerous as inflammable gases in explosive mixtures with air. The late Dr. R. V. Wheeler classified dusts in three groups, according to the hazard they present. Those listed in Class I ignite and propagate flame readily, the source of heat required being a comparatively small one such as a lighted

match, a short circuit, or the exposure of an incandescent filament. The chief difference between an explosion resulting from dust and one caused by a gas or vapour is that the latter is dependent on a supply of oxygen at the point of ignition, whereas each particle of dust is provided with its own surrounding envelope of oxygen, the propagation wave being thus limited only in the quantity of airborne dust or the space within which the explosion occurs.

Dust-Laden Atmospheres

Considerable attention is being devoted to the lighting of dust-laden atmospheres. One of the questions under investigation is whether the fittings used should be strong enough to resist an internal explosion, or whether efforts should be made to produce fittings which are perfectly dust-tight. The design of apparatus which can be made and kept dust-proof presents difficult problems, and in the present state of knowledge it seems safer to rely on flameproof equipment where dust hazards exist.

Under the Electricity (Factories Act) Special Regulations the appropriate authorities are given wide powers to control the installation of safety lighting equipment in inflammable or explosive atmospheres. The pertinent regulation (No. 27) contains no specific rules regarding electrical equipment for use in dangerous situations, each industry being held responsible for assessing its particular hazards and taking adequate precautions to meet them.

Where cellulose solutions are manufactured, used or stored, the Electrical Regulations are supplemented by the Cellulose

Holophane flameproof pendant unit No. F.9792A. This Buxton certified unit for gas Groups 2 and 3 combines the necessary robust construction with accurate control of the light by means of an internal reflector and front asymmetric lens giving a directional light distribution. The glass is smooth outside and the cast aluminium body is free of ledges and crevices where explosive matter might lodge. These lamps have been developed primarily for the lighting of control panels in oil refineries

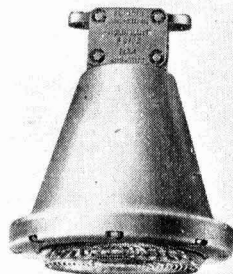

Industrial Safety

Regulations, Statutory Rules and Orders No. 990 of 1934. These provide that any source within a distance of 20 ft. must be so enclosed as not to ignite cellulose solutions or vapours. In practice, flameproof equipment is essential within cellulose spraying cabinets, and also in adjacent areas up to a 20 ft. distance, unless special permission is obtained from the Local Inspector for the use of enclosed (but not flameproof) fittings situated 8 ft. or more above floor level. No general ruling is given in this connection, each case being settled on its own merits. It is further provided that the overall temperature of lighting fittings in situations where cellulose residues may be deposited on them shall not exceed 180°F.

Premises where petroleum or explosives are stored are subject to the Regulations and Orders made under the Petroleum (Consolidation) Act and the Explosives Acts respectively. A memorandum regarding the installation of lighting equipment in explosives factories and magazines has been issued by the Home Office, while the Petroleum Institute has published an electrical code of safety practice.

There has recently been a tendency to insist on flameproof lighting equipment at or below ground level in garage pits where vehicles with a petrol content are under

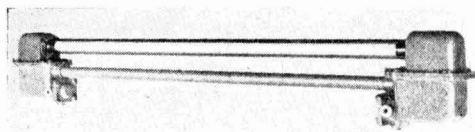

GEC flameproof fitting for 80 watt five ft. fluorescent lamp

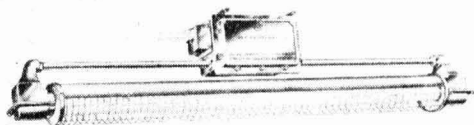

Crompton industrial type flameproof fitting 1 x 80 watt five ft. Buxton certificate Group 2 gases

repair. This requirement does not apply to inspection pits in industrial assembly when no petrol hazard is involved.

To satisfy British requirements for flameproof enclosures the minimum width of flange (with very few exceptions) must be one inch where the volume of the enclosure exceeds 100 cu. in. and $\frac{3}{4}$ in. where the volume is less than 100 cu. in. The maximum joint tolerance between the flanges must be 0.020 in. for Group 1, 0.016 in. for Group 2 and 0.008 in. for Group 3. The reduction in gap for Groups 2 and 3 is due to the higher speed of flame traverse of the gases concerned, which necessitates a throttling action to enable the flanges to cool the traversing flame.

The basic mechanical features of flameproof lighting fittings are set out in BS 229, which requires that all joints in a flameproof enclosure shall be either flanged, spigotted or screwed without the intervention of any loose or perishable packing. The terminal chamber must be a separate flameproof entity walled off from the main chamber by a solid flameproof partition, provision being made for sealing the incoming cables where necessary. The cables must be sealed on entry. The holes for studs and bolts used for attaching covers and other components must not pass through the wall of the enclosure, but must be either in external flanges or 'bottomed'. The covers must be secured by bolts or screws with heads which are adequately shrouded against unauthorized interference.

Design Standards

In designing flameproof lighting fittings account must also be taken of BS 889: 1947, which requires that the temperature rise in any part of the surface of a fitting shall not exceed 50°C with an ambient temperature of between 15 and 35°C. This standard applies only to fittings having glass covers, and these require to be of a certain minimum size for a certain wattage to ensure that the permissible temperature rise is not exceeded. There is at present no British standard specification which is applicable to covers of polymethyl methacrylate and other plastics materials.

Flameproof lighting fittings are subjected to mechanical tests and temperature tests, which are usually carried out at the manufacturer's works or elsewhere on the manufacturer's behalf. In addition, they are

Industrial Safety

tested for 'flameproofness' at the Ministry of Fuel and Power testing station. The mechanical tests are specified by BS 229, which requires that a specimen fitting must withstand an internal pressure of not less than $1\frac{1}{2}$ times the maximum pressure development while it is undergoing the flameproof test with inflammable gas, or of 50 lb. per sq. in. above atmospheric pressure, whichever is the greater. In addition to the type test, the testing authority may also demand an individual pressure test for each fitting as a condition of certification.

The flanged joint surfaces of every fitting are tested for deviations from the true plane surface and after the fitting has been assembled the gaps between these surfaces are also tested.

In addition, fittings are subjected to the particular tests applicable to well-glasses and bulkhead-type glasses used in flameproof lighting equipment, as described in BS 889.

The test for flameproofness is described in BS 229 and in the Ministry of Fuel and Power testing memorandum No. 4. The fitting is filled with and surrounded by the appropriate gas, mixed with air in the proportions that will provide the most explosive mixture within the fitting and also the mixture surrounding the enclosure that is most readily ignited by flame. The internal explosive mixture is then ignited under controlled conditions.

BS 889 requires that measurements to determine the maximum hot-spot temperature, which may be on the glass or body of the fitting, should be made with the fitting operating in its normal mounting position.

Each unit certified as flameproof must be

Below, left: GEC flameproof flood-light for 500 watt lamp. Below, right: Crompton flameproof fittings mining type lamp. Buxton certificate for Group 1 gases

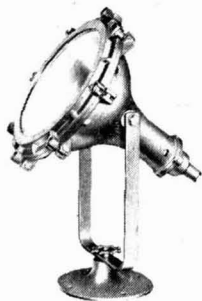

clearly and permanently marked with the registered flameproof marking consisting of the outline of a crown with the letters FLP inscribed therein. The number of the flameproof certificate and the group number or numbers indicating the group of gases covered by the certificate must also be marked. Care should be taken to ensure that the apparatus has been marked as being suitable for use in the group of gases relative to the industry in which it is to be used.

Any changes made in the design of a fitting previously certified as flameproof, intrinsically safe or approved must be notified to the certifying authority.

The range of flameproof lighting fittings now being manufactured in the United Kingdom is wide and the quality of lighting in hazardous situations has been very greatly improved during the past twenty years. In 1937 illumination in danger buildings rarely exceeded 1 lm./sq. ft. and in many instances the only artificial light entering the building came from simple well-glass units mounted outside fixed windows. To-day the average illumination in many danger buildings is 6-8 lm./sq. ft.

An example cited in a recent paper is that of a nitrating building in a nitro-glycerine plant. The nitrator and separator are mounted in a platform about 20 ft. above the floor and higher than the mound surrounding the building. The operator has to observe the mixing of liquids in the nitrator through a glass top-plate and to read a thermometer passing through the plate. Owing to the building construction light could not be admitted through the roof and for many years wall-mounted flameproof fittings were employed.

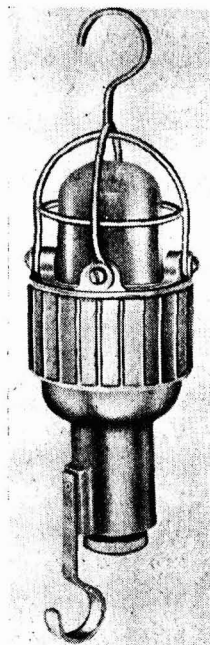

GEC flameproof handlamp for 15 watt lamp

Industrial Safety

the illumination being less than 1 lm./sq. ft. on the top plate of the nitrator. The difficulties of providing satisfactory lighting were overcome by mounting two flameproof footlights on the surrounding mounds and training their beams on to ceiling-mounted stainless steel plates from which the light is reflected to the nitrator. The illumination so obtained is about 20 lm./sq. ft.

Many problems associated with the use of lighting fittings in hazardous areas are under investigation, among them being the degree of safety afforded by the use of fluorescent lighting and hot cathode lamps.

Electronic Controllers

The lighting of danger buildings is likely to be influenced considerably by the increasing use of electronic controllers. Automation is still at an early stage of development, but it is evident that as more and more plants are laid down in which processes are automatically controlled from a central control room, problems of illumination in hazardous areas will be greatly eased.

Due to the experience and knowledge of the Electrical Inspectors of Factories, supported by the scientific and technical resources of the various large manufacturers of lighting fittings, rapid progress is being made in the lighting of hazardous locations in industrial plants. Through the Illuminating Engineering Society there is a constant interchange of information and ideas between plant engineers, lighting engineers, and representatives of Government departments.

Machinery also exists for an international approach to problems of lighting in corrosive atmospheres. A committee has been formed for this purpose by the international body, CIE, of which Great Britain is the secretariat country.

For the guidance of engineers and contractors in preparing schemes involving flameproof and intrinsically safe equipment, and of those responsible for the maintenance of such equipment, Code of Practice No. CP 1003:1948 has been prepared by a joint committee of the IEE and the BSI. It is highly desirable that before any scheme is decided upon it should be submitted to the local Electrical Inspector of Factories for his opinion.

Should the inspector decide that the installation must be of a flameproof character, it follows that all the fittings, together with the ancillary apparatus such as conduit or cables, must also be approved as flameproof. It is advisable for users to obtain particulars of the various specifications dealing with flameproof fittings in order that they may be fully informed of the numerous requirements.

Regular inspection of flameproof equipment is essential. Maintenance should be carried out by persons who have been instructed in the special techniques involved. Particular attention should be devoted to the various joints. It has been pointed out that the difference between a safe metal joint and an unsafe one might be in the order of 3/1000 in. and that this difference can readily be provided by a small speck of metal or dirt between the joint, or by a patch of rust. For this reason it is advisable during assembly to smear the opposing faces of each joint with an oily rag, and this procedure should always be repeated when any cover or lid is removed and replaced.

No attempt should be made to replace broken glass except by the complete assembly as supplied by the manufacturer of the fitting.

ACKNOWLEDGMENT

In preparing this article the following sources have been consulted:

- Richards, S. W., M.I.Min.E., 'Permissible Electrical Apparatus for Use in Hazardous Atmospheres' (Proceedings of the Second Annual Conference on Chemical Works Safety conducted by the Association of British Chemical Manufacturers, October 1949).
- Middleton, R. W., & Harper, W. E., 'Lighting in an Explosives Plant,' *Transactions of the Illuminating Engineering Society*, 1953, 18, (1).
- Strachan, D. A., 'The Design and Application of Flameproof Lighting Equipment,' *Transactions of the Illuminating Engineering Society*, 1954, 19, (6).
- Palmer, A. G., & Harper, W. E., 'The Lighting of Hazardous and Corrosive Locations in Industrial Plants', *Transactions of the Illuminating Engineering Society*, 1955, 20, (6).

Fatal industrial accidents in October in the UK totalled 114, 22 fewer than in the previous month, but four more than in October 1954. Of these three were recorded from chemicals, oils, soaps and allied trades. Four cases of lead poisoning were reported, compared with 10 in September. Of 16 cases of epitheliomatous ulceration (skin cancer) reported among pitch and tar, and mineral oil workers, two deaths resulted from mineral oil. There were 33 cases of chrome ulceration recorded.

Safety Notebook

THE 'Fire Protection Year Book 1956' is now available from Benn Brothers, 154 Fleet Street, London EC4. This is the 16th edition of what has come to be known as 'The Fire Fighters' Encyclopaedia'. To all concerned with the prevention and extinction of fire this is an extremely useful reference book. As in previous editions the subject matter is divided into eight comprehensive sections, each dealing with a particular phase of fire fighting or fire protection.

Section I constitutes a directory of all the public fire brigades and salvage corps in the British Isles; section II is a directory of industrial and private fire brigades; while section III relates to the fire services of the Commonwealth and Empire. In the enlarged section IV are given details of civil defence authorities and their officers; section V deals with Government departments and public authorities concerned with fire prevention; section VI contains particulars of associations, institutions and societies interested in or actually connected with fire fighting and fire prevention; section VII and VIII deal respectively with the legal aspects of fire safety and with fire engineering technicalities and essential statistics.

The 1956 Year Book includes a comprehensive list of suppliers of fire safety equipment, classified lists of such equipment, trade names and a useful desk diary. The cost is 12s 6d post paid or £1 per annum which also includes 12 monthly issues of *Fire Protection Review*.

* * *

PAPERS on a wide variety of natural and synthetic materials were read and discussed at a symposium on 'Flame Resistant Polymers' organized by *The Rubber and Plastics Age* and held at the National College of Rubber Technology, London N7, on 23-24 November.

In a paper, 'Prospects for the Application of Organic Fluorine Compounds', Professor M. Stacey of the University of Birmingham said that there appeared to be no reason why fluorine containing models of most of the well established man made poly-

mers should not be made. Fluorine containing acrylics were already well known in the US. In 'Organic Phosphorus Compounds for Textiles' F. Tattersall of Proban Ltd. discussed the flame-proofing of cellulosic textiles. He summarized the use of phosphorus compounds in the past and gave a short discussion on some of the latest methods, including THPC, brominated triallyl phosphate, bromoform-triallylphosphate polymer (BAP), combination BAP-THPC method and melamine pyrophosphoric acid.

The address of the organizers of this symposium is *The Rubber and Plastics Age*, 147 Grosvenor Road, London SW1.

* * *

THE drive to reduce foot injuries in industry has been greatly helped by the development of a style of safety footwear which, in outward appearance, is indistinguishable from the normal boot or shoe worn by the man in the street.

Just under eighteen months ago a Bristol company, Protective Footwear Service Ltd. of Kingswood, already known as suppliers of safety footwear for men, introduced a range specially created for women. These shoes, known as Nifties, have been a success and the company has now added to the range Nifties bootees. These are designed to give the fashion conscious woman worker a snug, warm bootee for cold weather wear which will have the same protective features as Nifties casuals.

Nifties bootees incorporate a concealed steel toe-cap which will, it is claimed, withstand falling weights of up to 40 ft. lb., and the uppers are of soft supple leather for smartness and long life.

Apart from the specially built-in safety features, the bootee style itself is particularly suitable for industrial wear, giving as it does extra protection to the ankle and instep.

Like Plus Fifty—a range of safety footwear for men—Nifties bootees are obtainable only through welfare departments of industrial organizations,

Safety Notebook

ACCIDENTS to rubber workers cost the industry £750,000 last year, Mr. F. I. Tuckwell, Dunlop's chief personnel officer, told the National Safety Conference for the Rubber Manufacturing Industry. This conference was held on 16-17 November at the Royal Empire Society, Northumberland Avenue, London WC2. There were, he said, 1,442 accidents entailing the loss of one day or more at a cost of about £500,000. Minor accidents on an average of just over three per rubber workers cost, at 18s each, approximately £250,000, a total estimated cost of £750,000 last year, equal to about £10 per rubber worker, or about £3,000 per working day. Let them set a target of 50 per cent saving for 1956, he urged: a saving of £5 per worker, £1,500 per day and a total of £375,000.

* * *

STANDARD labels for marking containers were shown at the Marking of Containers Exhibition held by the ABCM at ICI's Thames House, from 6 September to 28 October. A wide variety of labels were on view including stick-on, tie-on, stencilled and printed, but all incorporated certain basic principles. On each is the name of the substance, its degree of risk, i.e. danger, warning or caution, together with an indication of the nature of the risk, e.g. fire, poisonous vapours etc., and finally precautions to be taken in event of accident.

The illustration shows a typical stick-on label which includes, outside the main body of the label, a manufacturer's imprint.

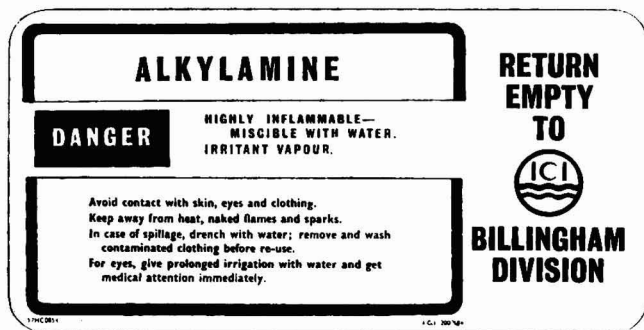

APPLICATIONS of nuclear physics to the problem of fire protection are described in a brochure published by the Minerva Detector Co. Ltd., Red Lion Street, Richmond, Surrey. The basis of the Minerva system is two ionization chambers, one sealed off and the other open to the air, connected to a cold cathode gas filled tube. The air in the ionization chambers is rendered conducting by the presence of a small quantity of radium. In the normal state the two chambers are in electrical balance. When smoke or other products of combustion enter the open chamber the ionizing effect is changed and the voltage across this chamber then rises sufficiently to raise the voltage on the trigger electrode of the valve above its critical value. The tube then passes a current of 10ma, sufficient to operate the relay controlling the alarm bells and signal lamps.

The manufacturers claim that tests carried out by independent public bodies concerned with fire protection have confirmed the rapidity and reliability of the Minerva system. Comparisons with conventional differential and thermostat detectors are given in the brochure. For example the Minerva system gave warning of an electrical coil overload in 2 min. 8 sec. while no alarm was obtained from a conventional detector in one hour.

* * *

WRITING in a pamphlet 'Fire Research & Factory Safety' reprinted from *The Journal of the British Fire Services Association*, Dr. F. E. T. Kingman, Ph.D., F.R.I.C., says that the ever-growing use of flammable liquids in industry has prompted the Fire Research Board to form a committee to study industrial hazards arising from the flammability of certain dusts, vapours and

Features of this label are that the nature of the danger is clearly marked and adequate safety precautions are given

gases, and to advise on a research programme to provide information that will enable industry to reduce the effects of these hazards. A problem more closely associated with common factory practice is that of explosions in oil drums and tanks undergoing repairs by processes involving heat, writes Dr. Kingman. This risk is well appreciated with liquids of low flash point, but the Factory Department of the Ministry of Labour has become concerned with the number of incidents occurring with oils with flash points well above room temperature. Tests were carried out with oils having a wide range of flash points from kerosene to vegetable oils. Explosions occurred under conditions not unduly drastic with kerosene and diesel oils, and although no explosions occurred with the higher-boiling oils, it is by no means certain that they could not occur under more drastic conditions. It is clear, therefore, says Dr. Kingman, that it is necessary to treat any drum or tank which has contained flammable liquid as a potential danger and to ensure that it is completely freed from flammable materials which might produce an explosive atmosphere before applying any source of heat.

* * *

A SECOND edition of the booklet 'Safety Measures in Chemical Laboratories' is now available from HMSO price 1s. 6d., by post 1s. 7½d. Prepared by the Department of Scientific & Industrial Research, the booklet is set out in easy-to-read form and all precautions described are based on the collective experience of the DSIR laboratory staff over a period of years.

In a preface to this second edition, Dr. D. D. Pratt, O.B.E., M.A., Ph.D., director of the chemical research laboratory at Teddington, Middlesex, writes: The belief that this booklet would be of considerable value in a wider field than our own laboratory was borne out by the large number of copies sold of the first edition. Many letters were received, some containing suggestions which have been included in the second edition.'

The first edition was compiled primarily for the guidance of new entrants to the chemical research laboratory, but was not intended as a final document as it did not pretend that it had covered all causes of chemical hazards.

In six chapters and two appendices the second edition covers general laboratory

Safety Notebook

operations, fire risks and burns, electric hazards and shock, dermatitis, poisons, poison gases and treatment of affected persons, type of general safety organization, and the standard form for reporting accidents.

* * *

SCRAPERS which are non-sparking and resist the corrosive action of a number of chemicals are being patented by Meigh Castings Ltd., Uckington Foundry, near Swindon Village, Cheltenham. This company claims that it has solved the problem of 'the tool that works loose on a wooden head'.

The handle is saw cut at the end, and after soaking in water to soften the wood, the end of the handle is pressed into the head where it encounters a pointed cross member made in one piece with the shell. This cross member forces the two portions of the slotted end apart, after which the restricted space in the shell forces them together, so that the two portions of wood grip the central member pincer fashion. As this device locks the head on the handle it enables both push and draw scraper blades to be mounted on the same handle. Besides being more convenient this is less tiring to the operator. A further feature is that the sides of each blade form an acute angle with the scraping edge and this ensures scraping up to a corner without difficulty.

* * *

FLAMEPROOF models of their column and panel type oil filled electric radiators are now being produced by Hurseal Ltd., 229 Regent Street, London W1. The head is constructed of non-welded cast steel and will not transmit any spark or flame. It is claimed that the introduction of the Hurseal flameproof head makes possible the space heating of special industrial projects where rigid control of the upper limit of surface temperature is a critical factor. An example of this is the manufacture of cellulose products where the solid residue of the cellulose solutions has a danger point of 180°F. Hurseal claim that they can produce an oil filled electric radiator which operates at a maximum surface temperature of 160°F.

Lion Oil Joins Monsanto

Both Companies to Benefit

AS REPORTED exclusively in THE CHEMICAL AGE on 1 October (p. 737) Lion Oil Co. Ltd. El Dorado, Arkansas, has been merged into Monsanto Chemical Co., St. Louis, Missouri, as an operating division. The importance of this move is illustrated by the prominence given to it in the October-November issue of *Monsanto Magazine*. 'From just about every standpoint' says the magazine, 'the two companies integrate perfectly. With progressive Lion Oil operating as a division of Monsanto, both companies, their employees, and their customers stand to benefit.'

Reasons for Merger

The reasons for the merger, which was approved on 23 September, are given in the magazine as follows.

'Monsanto has a big stake in the petro-chemical business but had no "shortage-proof" petroleum source and little knowledge of the business. Lion, with about 1,000 producing oil and gas wells (and others drilling in nine states) and excellent refinery facilities, provides the source and reserves.

'Monsanto and its associate companies are big consumers of ammonia. Lion is a major low cost producer of nitrogenous chemicals—ammonia and its derivatives.

'About half of Lion's sales and earnings are chemical, and these mesh right into Monsanto's production of insecticides, herbicides, and a considerable family of agricultural chemicals.

'Monsanto is the nation's largest producer of phosphorus, and, meeting the demand for greater and greater quantities of concentrated fertilizers, has developed a process for combining phosphorus and ammonia in liquid or solid form.

'Lion, with sales of chemicals and petroleum products now exceeding the \$100,000,000 mark annually, was at the point where extensive research and development programmes, and greatly increased markets were necessary for continued growth. Monsanto, with its excellent central research facilities at Dayton and at divisional locations, its deep-rooted belief in the necessity for fundamental long range and applied re-

search and its world wide marketing structure, filled Lion's needs.'

The 'dynamic' growth of Lion Oil Co. in the past 10 years is described in another article in the current issue of *Monsanto Magazine*. Describing the decade as 'the most phenomenal period of growth in the company's history' the article points out that Lion's assets in 1945 amounted to \$22,000,000 compared with \$150,000,000 in 1955. During this period sales quadrupled, net worth increased more than four times per share, and the company acquired more than five times as many shareowners. During those 10 years the company changed from a localized production, refining and sales company into a petro-chemical enterprise reaching into every state and into many foreign countries, with total sales of more than \$100,000,000 a year.

Nearly 1,000 oil and gas wells from the Gulf of Mexico to the Canadian border now yield up each day more than 26,000 net barrels of oil, which is approximately the amount of the daily throughput at Lion's refinery in El Dorado. This is about 2½ times the company's daily production in 1945.

Large Scale Nitrogen Production

More than 70 petroleum products are shipped from Lion's refinery all over America and to many foreign countries. In addition large quantities of nitrogen products are shipped from the company's chemical plants. It is estimated that altogether the company ships the equivalent of 65,000 railroad carloads of products each year.

The company's present exploration programme involves drilling oil and gas wells in nine states. This programme has resulted in discoveries in Kansas, the Williston Basin of North Dakota, and in South Texas. An indication of Lion's further future expansion in chemical marketing is a shiploading wharf being built at the Barton Plant on the Mississippi River, which will enable the company to load nitrogen products into either ocean-going vessels or barges for inland waterways.



BOILER HOUSE & POWER STATION CHEMISTRY. By W. Francis. 3rd edition. Edward Arnold Ltd., London. 1955. Pp. xii + 348. 50s.

In the United Kingdom a vast amount of coal is consumed annually in various types of boiler plant, probably over 90,000,000 tons. The efficiency with which it is burnt varies considerably and while the larger installations, for example those at power stations, usually operate under conditions of high efficiency, some smaller boiler plants operate wastefully and at the same time cause atmospheric pollution.

The book under review is divided into two parts. The first deals with those aspects of fuel technology of interest to the works chemist, combustion engineer or other person in charge of boiler plant. The second part deals with the analysis of fuels, flue gases, water and related topics.

The author, who is an authority on the constitution and properties of coal, naturally deals at some length with these topics. The classification of coal is discussed and in addition to the Fuel Research and National Coal Board system of classification, methods devised by both Seyler and the author are presented. Attention is also paid to the important topics of clinker formation, boiler deposits and boiler availability. The efficient combustion of coal in boilers is discussed and the importance of automatic recording of the carbon dioxide content of fluid gases is stressed. Rather surprisingly, however, no mention is made of the thermal conductivity instrument for this purpose although this is probably the best type.

Combustion calculations and the heat balance are dealt with and the construction and uses of the I.t. diagram of Rosin and Fehling are described. Combustion calculations based upon the use of the mol., are, in the reviewer's opinion, preferable to those employing more laborious methods and the use of this system would have rendered

'Boiler House & Power Station Chemistry' more valuable to students.

Heavy fuel oils are being used increasingly and the combustion of these and other alternative fuels is considered.

There is growing anxiety about atmospheric pollution and a valuable chapter deals with grit removal from flue gases and reviews methods for the removal of sulphur oxides. The systems of flue gas washing used at Battersea and Fulham are described.

Water treatment and corrosion in boilers are dealt with and a chapter on turbine, switch and transformer oils is included.

Part II deals with standard methods for the analysis of coal, ash, grit, flue gases and water, together with methods for the control of flue gas washing and for the examination of turbine and insulating oils. This section will be of value to chemists engaged in fuel and power station laboratories.

This book will be of interest to most fuel technologists, but it should primarily be in the hands of those who are responsible for the technical control of boiler plant. By raising the general level of efficiency of works boiler plant to that of the better ones, much fuel could be saved. This book in the hands of the right men might do much to bring this about.—R. LONG.

RATIONAL APPROACH TO CHEMICAL PRINCIPLES. 2nd edition. By J. A. Cranston. Blackie & Son Ltd., London. Pp. xii + 231. 10s 6d.

Although the historical developments of chemical theory are an excellent exercise and discipline in logic and the scientific method, their use in teaching may lead to difficulty. The student may find them hard to follow and in later work may have to modify his views and reinterpret his facts in the light of newer theories. This book is an attempt to overcome such difficulties. Omitting much of the historical development, the physicist's atom is used as a starting point, leading to stoichiometry, valency,

reactivity and the ionic hypothesis. With the formulation of the mass action law the aim is to provide a basis for the interpretation of chemical facts.

The book is divided into five sections, the first of which includes a very brief account of atomic structure and a more detailed consideration of electronic arrangement. The second deals with states of matter. The gas laws, deviations from them, vapour densities and the kinetic theory of gases are considered briefly. A chapter on the liquid state considers vapour pressure, factors affecting it, and mixtures of liquids. A further chapter deals with the properties of dilute solutions. The third section, dealing with chemical combination, includes a concise account of chemical bonds and a chapter on energy of chemical combination. This latter is intended by the author to lay a foundation for the subsequent study of thermodynamics. In view of this it is perhaps a pity that heat evolved is given a positive sign.

The last two sections, comprising over half the book, deal in some detail with electrically charged atoms and with chemical equilibrium. The concept of electrode potential is used to introduce the electrochemical series and properties related to electrode potential are considered. Oxidation and reduction are considered from an electrical standpoint, redox potentials are discussed and there is a chapter outlining the ionic theory. The law of mass action is discussed in some detail and there is a useful chapter in which the influence of temperature and pressure changes on chemical equilibrium is illustrated by reference to typical industrial reactions. Some carefully chosen examples illustrate the principles of heterogeneous equilibrium and a chapter on ionic equilibrium includes such topics as acids and bases, their strengths, the dilution law, hydrolysis and solubility product. There is an appendix on *pH* measurements dealing with the use of indicators and electrical methods and with *pH* changes during acid/base titrations. Problems, which seem to have been carefully chosen, follow each chapter and there are a number of miscellaneous problems, with answers, at the end of the book.

Although the book would seem to provide a rational basis for the understanding of many chemical facts it requires, in certain respects at least, supplementing by other text books or lectures. Experimental

methods generally are given in bare outline or not at all. The section dealing with states of matter is rather sketchy, particularly with regard to the colligative properties of solutions. Buffer solutions are only briefly considered. In spite of these limitations the book can be recommended as providing an interesting and stimulating approach to physical chemistry which should be within the grasp of the average student.—W. R. MOORE.

PHYSICAL CHEMISTRY. By F. Daniels & R. A. Alberty. J. Wiley & Sons Inc., New York; Chapman & Hall Ltd., London, 1955. Pp. vii + 671.

Many readers of this review will have first come to 'know' physical chemistry in the pages of Farrington Daniels' famous 'Outlines'. That the present volume is an up-to-date and extended version of the earlier work will be for such readers adequate assurance of its excellence. Professor Daniels is a gifted teacher of over 40 years' experience, and in the present instance he has found a very able collaborator in Dr. Alberty.

As previously, the emphasis in the book is on basic principles and their immediate applications. The presentation is lucid and on an elementary level, but nowhere does simplicity of treatment lead to misrepresentation of fact or idea.

Important changes have been made in the chapters on crystals, colloids, and ionic equilibria, while completely new material concerning high temperature equilibria, elementary statistical mechanics, light scattering by polymer solutions, microwave spectroscopy and enzyme catalysis has been introduced. To make way for these additions some of the very elementary material of previous editions has been eliminated, and other sections have been suitably condensed.

Typical problems based on the topic under consideration are fully worked out in the text, while comprehensive lists of problems to be attempted by the reader are given at the end of each chapter.

As a first course in physical chemistry this book can have few, if any, equals. It will be welcomed by teacher and pupil alike. It is elegantly produced, has good author and subject indexes, and is worth the money.—H. MACKLE.

HOME

Vacuum Oil Co.

On 1 December the name of the Vacuum Oil Co. was changed to Mobil Oil Co. Ltd. The company is a wholly owned subsidiary of Socony Mobil Oil (formerly Socony-Vacuum Oil) of the US, which acquired Powell Duffryn's 50 per cent interest a year ago.

British Association of Chemists

Mr. G. T. Gurr, F.R.I.C., the president, will be in the chair at the 38th annual general meeting of the British Association of Chemists at the Grand Hotel, New Brighton, Cheshire, on 10 December at 2.30 p.m.

Standardization Committee

The committee formed by the International Organization for Standardization which met in London recently under the aegis of the BSI to discuss the simplification and standardization of the names of chemical products used to fight destruction caused by insects and other pests in agriculture approved the first list of 29 names. A second list of 10 names was accepted provisionally. An official list will be published after ratification of the names by the countries concerned and by the council of ISO. A general agreement was reached that common names for new pest control chemicals should be coined by the countries originating them.

Gastechnik Purifiers for ICI

In connection with the new ICI project at Billingham for producing ammonia from synthesis gas made by pressure gasification of oil with oxygen (cf. *THE CHEMICAL AGE*, 1955, 73, 1044). Imperial Chemical Industries Ltd. have placed an order with Robert Dempster & Sons Ltd., of Elland, for Gastechnik purifiers using pelleted oxide of iron. A pressure section will remove the hydrogen sulphide remaining after a pressure washing process, and a low pressure section will remove the hydrogen sulphide from the carbon dioxide liberated from the washing process. As an essential to the process, the plant will include a solvent extraction process for recovering sulphur from the spent pellets, which will then be re-used.

Move to Larger Factory

Premier Colloid Mills Ltd., manufacturers of laboratory and industrial mixers, and colloid mills, have moved from Belvedere, Kent, to a larger factory at Hersham Trading Estate, Walton-on-Thames, Surrey.

Kent Long-Service Awards

Long-service certificates were presented by Commander Philip W. Kent, RN, chairman of George Kent Ltd., at the annual presentation ceremony at the Luton works on 18 November. Four members received the award for 50 years' service, and 28 the certificate marking the completion of 25 years' service.

Midland Branch Dinner & Dance

The annual dinner and dance of the Midland branch of the Institute of Metal Finishing will be held at the Grand Hotel, Colmore Row, Birmingham, on 19 January. Applications for tickets (price 35s each) should be made to: The Hon. Secretary, Midland Branch, The Institute of Metal Finishing, Westalite House, Bradford Street, Birmingham 5. Reserved tables for the dance period can be booked through the Grand Hotel.

Discussion Meeting

Sir Henry Tizard, G.C.B., A.F.C., F.R.S., past chairman of the Advisory Council on Scientific Policy & Defence Research Policy Committee, will be the chairman at a discussion entitled 'Government Responsibility in Industrial Research' to be sponsored by the Society for Visiting Scientists at 5 Old Burlington Street, London W1, on 6 December at 7.30 p.m. The speakers will be Dr. E. W. R. Steacie, O.B.E., D.Sc., F.R.S., and Dr. B. K. Blount, M.A., B.Sc., D.Phil. Nat., F.R.I.C.

Guest of Honour

Guest of honour at the annual dinner and dance of the Society of Cosmetic Chemists at the Cafe Royal, Regent Street, London W1, on 13 January, will be Dr. D. W. Kent-Jones, B.Sc., Ph.D., F.R.I.C., the President of the Royal Institute of Chemistry. Tickets for the dinner and dance, also available to non-members of the society, can be obtained from Mr. F. Riley at 140 Park Lane, London W1, price 30s.

. OVERSEAS .

Three Technical Consultants

It has been reported in New Delhi that Costain-John Brown of Britain, Saint-Gobain of France, and Vitro Engineering of the US have been appointed as technical consultants to prepare preliminary reports for a heavy water plant and a fertilizer factory to be set up in the Punjab.

Petro-Chemicals Expansion

World output of petro-chemical products last year was about 700,000 tons, and by 1960 the output is expected to be in the region of 2,500,000 tons. Seven years ago the world output was only 30,000 tons.

Iraq Refinery Opened

Iraq's first government-owned oil refinery, at Daura, on the River Tigris, three miles south of Baghdad, was opened on 28 November by King Feisal. The capacity of the refinery, which cost more than £11,000,000, is estimated at 24,000 barrels of crude oil a day, though experience of running-in the plant before the official opening shows it is capable of handling 27,000 barrels. This can be increased to 30,000 barrels a day by minor additions of equipment.

Turkish Pharmaceutical Factory

The cornerstone was recently laid in Istanbul of a pharmaceutical factory, which is being built by leading West German chemical firms as well as Turkish capital. On completion, the factory will turn out pharmaceutical specialities. The participating German corporations are said to be: Farbenfabriken Bayer A.G., Leverkusen; E. Merck, Darmstadt; Knoll A.G., Ludwigshafen; and Schering A.G., Berlin.

NPs in Full Production

Commercial Solvents Corporation announces that it has brought nitroparaffins, a new chemical family, into full commercial production at a plant at Sterlington, Louisiana. The plant is said to be the first of its kind in the US. Known as NPs, nitroparaffins have a wide range of applications in manufacturing processes and in the development of new products. Among their applications are new types of agricultural fumigants, insecticides, cosmetics, paint, hard waxes and an aircraft fuel that can be used at altitudes where no oxygen exists.

Oil & Gas Unity

Business groups in Western Canada interested in oil and gas production have united with the West German Phönix Rheinrohr Co. to found a company, the Alberta Phönix Tube & Pipe Ltd., which is to build a plant in Edmonton, Alberta, at a cost of \$7,000,000.

Oil Pipeline Tests

Recent tests carried out on the 15-mile oil pipeline from Kwinana to Fremantle, Western Australia, are expected to provide information to guide designers of pipeline. The tests took the form of temperature studies of the oil during the time it took to travel from Kwinana to Fremantle.

Jordan Oil Refinery

Comprimo Ltd., a Dutch company, is preparing plans for an oil refinery to be built in Jordan to refine 200,000 tons of oil a year. This is the amount of oil, under a contract with Aramco, that the Jordan Government is permitted to extract from the pipeline which runs from Saudi Arabia through Jordan territory.

NZ Cement Co. Formed

A new company, the New Zealand Cement Co., is to be formed to operate a cement works to be constructed at Westport, New Zealand. The works will have an annual capacity of 100,000 tons. The sponsors of the scheme are Tunnel Portland Cement, in association with Wm. Baird & Co., Wm. Cory & Son, and the Northern Mercantile & Investment Corporation. Each of the four sponsors are subscribing £250,000 of ordinary capital.

Atomic Oil Refining

Esso Research & Engineering Co., Linden, New Jersey, announced last week that petrol had been refined from crude oil for the first time by atomic radiation in laboratory experiments. The company stated that this might open the way to cheaper and more efficient refining of petrol, lubricating oils and heating oils by eliminating the need for the costly external heating equipment needed in the conventional method. According to the company, the new process resulted in even greater quantities of petrol from oil.

PERSONAL

Laporte Industries Ltd. have recently announced three new appointments to subsidiary companies. MR. D. H. CUTLER, M.A., and MR. W. S. WOOD, B.Sc., F.R.I.C., A.M.I.Chem.E., have been appointed directors of Laporte Chemicals Ltd. and MR. J. T. RICHMOND, M.A., B.Sc., F.R.I.C., M.Chem.E., appointed a director of Laporte Titanium Ltd.

Pharmaceutical Specialities (May & Baker) Ltd. have appointed MR. R. W. E. WOOD, M.P.S., and MR. R. PAISLEY to their board of directors. Mr. Wood joined the company in March 1940 after 14 years in retail pharmacy. He has worked as a production chemist and sales executive and in February 1949 he became home sales manager. Since 1951 Mr. Paisley has been in charge of the veterinary division of Pharmaceutical Specialities.

Nordac Ltd., chemical engineers of Uxbridge, Middlesex, have appointed MR. S. J. REASON, D.L.C. (Eng.) as their technical sales representative in the North of England. Mr. Reason, who recently joined the staff of Nordac Ltd., is based in Huddersfield, Yorkshire. Previously the company has covered the North of England from its Uxbridge office.

The appointment of DR. T. R. MILLER, B.Sc., Ph.D., as director of development of Carbide & Carbon Chemicals Co., a division of Union Carbide & Carbon Corp., was announced recently by MR. D. B. BENEDICT, vice-president of Carbide & Carbon Chemicals. Dr. Miller joined Carbide & Carbon Chemicals Co. as a chemist in the process development laboratory in South Charleston, West Virginia, later becoming director of plant laboratories which post he held at the time of his new appointment.

MR. C. D. O'SULLIVAN, managing director, Walter Carson & Sons Ltd., has been appointed president of the Society of British Paint Manufacturers for the year 1955-56, and MR. T. S. DALLY, assistant managing director, Pinchin Johnson & Associates Ltd., and a director of Styrene Copolymers Ltd., has been appointed vice-president.

MR. A. RAYMOND KEY has been appointed vice-president of Johnson, Matthey & Co. Inc., the American associate of Johnson, Matthey & Co. Ltd. Mr. Key joined the Birmingham branch of the parent company in April 1935 where he remained until October 1939. After war service he returned to Birmingham in 1946. In January 1952 he joined the company's head office in Hatton Garden, London, and later in that year made an extensive tour of the US. He was transferred to the staff of Johnson, Matthey & Co. Inc., in New York, in April 1953.

MR. D. D. MORRIS, B.Sc., has been appointed to the newly created position of assistant to the general manager of The Consolidated Mining & Smelting Co. at Trail, British Columbia. Mr. Morris, who joined the company as an assayer in 1928, was transferred to research work in the chemicals & fertiliser department in 1936. From 1941 until 1943 he was superintendent of the ammonia plant at the Alberta nitrogen department in Calgary. In 1949 he was appointed general superintendent of the Calgary department, where he remained until going to Trail as general superintendent of the research and development division the same year. He became manager of the division in 1951. Born in Edmonton, Mr. Morris attended the University of Alberta where he received his B.Sc. degree in chemical engineering in 1928. He is a fellow of the Chemical Institute of Canada and a member of the Engineering Institute of Canada and the Association of Professional Engineers of BC.

DR. RAY P. DINSMORE, vice-president in charge of research and development of the Goodyear Tyre & Rubber Company, received the 1955 Charles Goodyear Medal at a banquet of the American Chemical Society's division of rubber chemistry, Philadelphia, on 17 November. A widely known authority on natural and synthetic rubber, Dr. Dinsmore has received international recognition for his many contributions to the rubber industry, and as assistant deputy rubber director for the United States during World War II he organized and directed research and development on synthetic rubber in various laboratories.

The 1955 Southern Chemist Award of the American Chemical Society's Memphis section was conferred on 4 November upon DR. JAMES TUCKER MACKENZIE, technical director of the American Cast Iron Pipe Company, Birmingham, Ala., during the Society's Southeastern Regional Meeting at Columbia SC. Dr. MacKenzie, an international authority on the chemistry and metallurgy of cast iron, was honoured for his important research and his scientific reports in this field and for his many years of service in offices and committees of his professional societies.

Obituary

PROFESSOR H. R. ROBINSON, F.R.S., Vice-Chancellor of London University from June, 1954, until his resignation for health reasons at the beginning of this month, died at his home in London on 28 November at the age of 66. He was appointed professor of physics at Queen Mary College, London, in 1930 and for the last seven years of that appointment was also vice-principal of the college. He retired on medical grounds in 1953 but came back to the university as Vice-Chancellor on the retirement of Sir Roderic Hill in 1954.

Coating for Tank Linings

A MAJOR advance towards greater long-range economy in the transportation of corrosive chemicals was claimed recently when a 4,050 gallon highway tank-trailer—protected against corrosion for the first time with a new fluorocarbon plastics coating—began hauling sulphonic acid for a leading detergents manufacturer.

The new high temperature-resistant, chemically inert coating is a KEL-F plastics dispersion, developed by The M. W. Kellogg Co.

'The use of this new coating for tank-linings will permit the chemicals produced to ship a volume of corrosive products in one shipment two-to-three times greater than that possible previously,' stated Mr. Walter Merck, sales manager of Kellogg's chemicals manufacturing division. 'To reduce the effect of a corrosive product, such as nitric acid, on the vessel in which it is being trans-

ported,' he said, 'it has been current practice to "neutralize" the product by dilution with water, often as high as 50-60 per cent. Since the new KEL-F coatings are chemically inert, highly corrosive products may be shipped in concentrated form, and because of the coating's high temperature resistance, may also be poured and carried hot.'

Irish Pharmacy Bill

Poisons Board for Ulster

THE TEXT of a new Northern Ireland Pharmacy and Poisons Bill has been published in Belfast.

Its principal objects are to establish a poisons board for the Ulster area; to define the powers and constitution of the Pharmaceutical Society; to extend the powers of the council of the society; and to change the present arrangements for apprenticeship and examination.

One of the first duties of the new poisons board will be to prepare a list of poisons for the Minister of Home Affairs. This list, which must be approved by the Minister, will be amended from time to time within the framework of the new bill. The measure also provides for the registration by a county borough or county council of persons—other than chemists—who are entitled to sell certain poisons.

A special provision in the bill is designed to protect the chemists' profession from misrepresentation by any person registered with a local authority. The objects and powers of the Pharmaceutical Society—which Northern Ireland chemists have described as 'vague up to the present'—are clearly defined, and the council's powers (when the bill is passed) will be considerably extended.

The period of apprenticeship is reduced from four years to two years. The remainder of the qualifying period—three years—will be spent in full-time approved courses of study.

The bill will go before the Northern Ireland Parliament shortly.

Textile Conversazione

The Textile Institute will hold its second annual Conversazione at the University of Leeds on 16 December.

DSIR Invites Suggestions

PRIVATE companies and research organizations are being invited to submit particulars of new products and new processes to the Department of Scientific & Industrial Research who, in co-operation with the British Industries Fair, is arranging a display of new products and new processes developed by research irrespective of where the research was done. The display will be shown at Castle Bromwich from 23 April to 4 May 1956. It is also proposed to show the same display at the Production Exhibition at Olympia, London, from 23 to 31 May.

All of the products and processes which are selected will be considered by the DSIR when advice is requested by other Government departments on material for official stands at overseas fairs. At the BIF and the Production Exhibition the design and construction of stands will be paid for by DSIR, although the guest exhibitors will be expected to meet the costs of transport and erection of their products. They will also be expected to staff their stands.

Information of new products and new processes should be sent to the Chief Information Officer, Department of Scientific & Industrial Research, 5-11 Regent Street, London SW1, not later than 20 December.

Chemical Expansion in Hungary

Output of the chemical industry in Hungary is planned to increase 13.8 per cent next year, Mr. Andor Berei, chairman of the National Planning Committee, told Parliament when he announced next year's economic plan. Nitrogen fertilizer production is to be more than tripled, he said, and greater quantities of medicines for home and export purposes will be made. There is to be increased use of plastics and artificial fibres in light industry. One of the biggest projects of the second five-year plan, of which 1956 is the first year, will be the Tiszamenti Chemical Works, which is to process natural gas piped from Rumania. Building of the works is to begin next year and it is due to commence production of synthetic chemical materials and plastics in 1959.

CHEMICAL LEAD

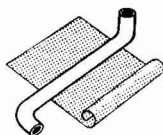

B.L.M. supplied a very large tonnage of chemical lead sheet and pipe for the Marchon Products Plant.

British Lead Mills

BRITISH LEAD MILLS LTD · BYRON HOUSE · 7-8-9 ST. JAMES'S STREET,
LONDON · S.W.1 · WORKS : WELWYN GARDEN CITY · HERTS

A member of the  Firth Cleveland Group

Company News

Albright & Wilson Ltd.

Arrangements have been completed for the purchase at 1s 4d each of about 2,000,000 new shares in Albright & Wilson Ltd., nil paid, to which 'family' interests and past and present members of the staff and their families will be entitled. These shares have been placed in firm hands at 1s 6d each. The total 'rights' offer was of 6,084,852 ordinary shares at 15s 6d each. The arrangement was made because it was known that many of the holders concerned would not be able to take up their full entitlement, amounting to nearly half the issue, and it was clear that to offer them on the market when dealings commence would tend to depress the price to the detriment of the stockholders as a whole.

Laporte Industries Ltd.

Laporte Industries Ltd. announce that the acceptances of their recent offer to ordinary stockholders of 3,245,897 ordinary shares of 5s each at 12s 6d per share totalled over 98 per cent. Applications for 'additional' shares amounted to more than 20 times the number of shares available and they have been allotted on the following basis: applications for up to 20 shares, allotted in full; applications for more than 20 shares, allotted 20 shares each.

Incedon & Lamberts Ltd.

Incedon & Lamberts Ltd. have acquired a controlling interest in Richard E. DuPont Ltd. Announcing this at the company's annual general meeting in London on 24 November, the chairman, Mr. G. H. Incedon, said that the directors of DuPont had made a special study of modern plastics materials and methods of production of high grade corrosive resistant pipes, fittings and ducts. Production would shortly commence and supplies would be available under the trade name Durapipe. A full range of products in three new materials would be marketed. Each material had different characteristics which would enable broader industrial applications for these modern plastics products than had hitherto been possible.

Glaxo Laboratories Ltd.

During the year ended 30 June 1955 Glaxo Laboratories Ltd. continued to ex-

perience difficult trading conditions, but despite these difficulties the group more than maintained its position, and progress was made, although at reduced profit margins. World-wide sales increased during the year by 8 per cent, and a £600,000 development programme was begun. Difficulties in certain South American companies continued, and as in the past, with the consent of the Board of Trade, the accounts of these subsidiary companies were not consolidated. Two of the South American companies made losses amounting to £18,000. In his statement to stockholders, the chairman and managing director, Sir Harry Jephcott, M.Sc., F.R.I.C., F.P.S., said: 'In the present uncertain state of the world, the devaluation of currency, such as recently took place in Pakistan, may result in losses which, in so far as they relate to the book value of fixed assets, are more nominal than real. Nevertheless, world-wide trading cannot be conducted without the risk of exchange losses. In the past five years Glaxo has invested more than £2,000,000 in overseas subsidiary companies.' Net profit of the group for the year, after providing for taxation, was £1,476,079 to which has been added £420,130 brought forward from last year. Of this, £1,100,000 has been transferred to reserves, and the proposed final dividend on the ordinary stock is 10 per cent, less tax. The annual general meeting will be held in London on 13 December.

Manchester Oil Refinery (Holdings) Ltd.

When announcing the interim dividend of 4 per cent, less tax, the directors of Manchester Oil (Holdings) Ltd. informed stockholders that the current year's profits will be lower than those for the previous financial year. If present trading conditions are maintained in the remaining weeks of this year, the board expects to recommend a final dividend of 8½ per cent, less tax, making a total distribution of 12½ per cent, less tax, as in the previous year. During last year the company began a programme for developing several new products, including fine chemicals. Demand for these products entailed the extension of production facilities which gave rise to some technical difficulties which are expected to be reflected by a reduction of the group's profits.

ANCORITE

ACID-PROOF BRICK LININGS

were installed in all the

REACTORS

ABSORPTION TOWERS

DRYING TOWERS • HAIRPIN COOLERS

CIRCULATION TANKS

at

SOLWAY CHEMICALS LTD.

NEW PLANT AT WHITEHAVEN.

* * * * *

ANCORITE

ANTI-CORROSIVE PAVINGS

were used throughout for plant floor protection

ANCORITE LIMITED

or

THE GENERAL ASPHALTE CO. LTD.

(CHEMICAL ENGINEERING DIVISION)

Grafton Road, London, N.W.5.

Telephone : GULLiver 7171.

Telegrams : Genasphalte, London.

Next Week's Events

MONDAY 5 DECEMBER

The Chemical Society

Belfast: Queen's University, 7.45 p.m. 'Recent Advances in the Vitamin D Field' by Professor B. Lythgoe, M.A., Ph.D., F.R.I.C.

SCI (Oils & Fats Group)

Leeds: The University, 7 p.m. 'The Production & Properties of Fatty Alcohols' by A. C. Halfpenny, B.Sc.

TUESDAY 6 DECEMBER

SCI (Plastics & Polymer Group)

London: Rooms of The Chemical Society, Burlington House, Piccadilly W1, 6.30 p.m. 'Second Order Transitions in High Polymers' by Dr. M. Gordon, M.Sc., Ph.D.

Institution of Chemical Engineers

London: The Geological Society, Burlington House, Piccadilly W1, 5.30 p.m. 'Distillation of Liquid Hydrogen' by Professor E. S. Sellers, M.A., M.Sc., & D. R. Augood, B.Sc., Ph.D.; & 'Transient Behaviour of Plate Distillation Columns' by J. F. Davison, B.A.

Chester: The Grosvenor Hotel, 7 p.m. 'The Impact of Industry on the Young Chemical Engineer' by H. Fossett, M.I.Mech.E.

Society for Visiting Scientists

London: 5 Old Burlington Street, W1, 7.30 p.m. 'Government Responsibility in Industrial Research' by E. W. R. Steacie, O.B.E., D.Sc., F.R.S.; & B. K. Blount, M.A., B.Sc., D.Phil. Nat., F.R.I.C.

SCI (Midlands Section)

Birmingham: Birmingham & Midland Institute, Paradise Street, 6.30 p.m. Joint meeting with RIC. 'Gas-Liquid Partition Chromatography' by N. H. Ray, B.Sc.

Society of Instrument Technology

London: Manson House, Portland Place, W1, 6.30 p.m. 'Planning a Servo-mechanisms Laboratory for Instructional Purposes' by E. B. Pearson, M.Sc., F.Inst.P., A.M.I.E.E.

WEDNESDAY 7 DECEMBER

Institute of Fuel

London: Institution of Civil Engineers, Great George Street SW1, 5.30 p.m. 'Power Population & Productivity' by Dr. A. Parker, C.B.E.

Institute of Metals

London: Grosvenor Gardens SW1, 6.30 p.m. 'A Report on the Recent Paris Low-temperature Conference' by Sir Francis Simon, C.B.E., F.R.S.; Dr. P. L. Smith; & Dr. H. M. Rosenberg.

SCI (South Wales Section)

Newport: Technical College, 7 p.m. 'New Products from Coal Tar' by D. McNeil, B.Sc., Ph.D.

SCI (Liverpool Section)

Connah's Quay, North Wales: Flintshire Technical College, 7.30 p.m. 'Instrumentation in the Chemical Industry' by C. R. Evans.

Society for Analytical Chemistry

Birmingham: The University, Edmund Street, 7 p.m. 'Some Physical Methods for the Analysis of Phosphorus Compounds' by Dr. D. E. C. Corbridge.

Institution of Chemical Engineers

Leeds: The University, 7 p.m. 'Phenolic Effluent Disposal' by D. A. Hall, Ph.D., F.R.I.C.

THURSDAY 8 DECEMBER

SCI (Microbiology Group)

London: Medical Society of London, 11 Chandos Street, Cavendish Square W1, 6.15 p.m. Domestic meeting. 'The Formation & Utilisation of Acetic Acid by Strains of *Acetobacter* in Malt-vinegar Acetifiers'; 'Morphological & Biochemical Changes Induced in Certain *Acetobacter* Species'; 'Vinegar Making in Practice'.

SCI (Edinburgh Section)

Edinburgh: North British Hotel, 7.30 p.m. 'Some Aspects of Research in the Scottish Division of the National Coal Board' by E. A. C. Chamberlain, B.Sc., Ph.D., A.R.C.S., D.I.C., F.Inst.F.

SCI (Notts Section)

Nottingham: Gas Showrooms, 7.30 p.m. 'Organic Chelating Agents as Aids to Industry' by A. Taylor, B.Sc., F.R.I.C.

RIC (London Section)

London: Battersea Polytechnic, Battersea Park Road SW1, 6.30 p.m. 'Surface Chemistry' by Professor Sir Eric Rideal, M.B.E., F.R.S.

Society of Cosmetic Chemists

London: The Royal Society of Arts, John

[continued on page 1236]

three-tier laboratory ball mill

The new No. 6 Model Ball Mill will prove very useful for carrying out a number of separate jobs or working with different materials. It is arranged with three pairs of $2\frac{1}{2}$ in. diameter rolls mounted one above the other in three tiers. It has three motors with variable speeds and all three tiers can be operated simultaneously or one or two separately. Each pair consists of one driven roll and one idler, and the latter can be placed in any of three positions to accommodate containers up to 9 in. diameter.

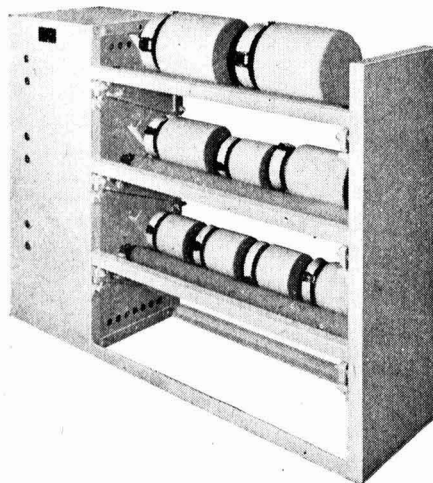

PASCALL

Write for list G.612 or
Telephone Paddington 7236/7

THE PASCALL ENGINEERING CO · LTD

114 · LISSON GROVE · LONDON · NW1

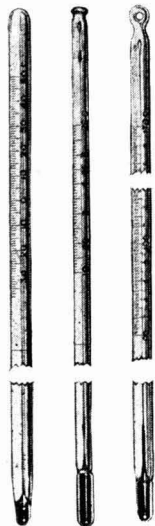

ZECOL

REGD. TRADE MARK

THERMOMETERS



CHEMICAL THERMOMETERS

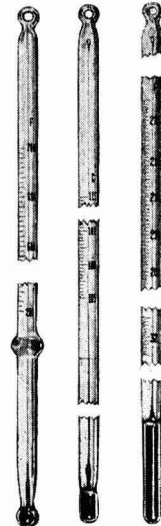

HYDROMETERS

PHONE :
LIBERTY
2283-6

G. H. ZEAL LTD.

GRAMS :
ZEALDOM
SOUPHOM
LONDON

LOMBARD RD., MORDEN RD., MERTON, LONDON, S.W.19.

Next Week's Events

continued from page 1234

Adam Street, Adelphi, WC2, 7.30 p.m.
'Some Aspects of Perfumery Chemicals' by
A. J. Krajceman, Dipl., Ing. Chem., A.R.I.C.

Institute of Physics

Harwell: Visit to Atomic Energy Establishment, 11.15 a.m., followed by talk on
'Atomic Power' by D. J. Littler, F.Inst.P.

The Chemical Society

Dundee: Queen's College, 5.15 p.m.
'Magnetism & the Structure of Inorganic Molecules' by Professor R. S. Nyholm, M.Sc., A.R.I.C.

Textile Institute

Galashiels: Scottish Woollen Technical College, 7.30 p.m. 'Colour Theory & Colour Matching' by T. Vickerstaff, M.Sc., Ph.D., A.R.I.C., F.S.D.C.

FRIDAY 9 DECEMBER

Textile Institute

Dundee: Technical College, 7.30 p.m.
'Colorimetry & Colour Gamuts' by T. Vickerstaff, M.Sc., Ph.D., A.R.I.C., F.S.D.C.

SCI (Aberdeen Section)

Aberdeen: Marischal College, 7.30 p.m.
'Some Chemical Aspects of Cell Structure' by Professor J. N. Davidson, D.Sc., M.D., F.R.F.P.S.G., F.R.S.E.

Institute of Physics

Liverpool: Department of Electrical Engineering, University of Liverpool, 7 p.m.
'Atomic Energy for Power Production' by Dr. S. C. Curran, F.R.S.

SCI (Fine Chemicals Group)

London: Chemistry Lecture Theatre, King's College, WC2, 7 p.m. 'Recent Work on the Tropane Alkaloids' by Dr. F. R. Smith.

Royal Institute of Chemistry

Reading: Technical College, 5.45 p.m.
'Debate on the Education of Scientists' by Dr. F. M. Brewer & Dr. D. T. Lewis.

SATURDAY 10 DECEMBER

Society for Analytical Chemistry

Cardiff: Council Chamber of the City Hall, 2.30 p.m. Joint meeting with the Association of Public Analysts. 'Sucrose Loss from Ice Cream Storage' by H. J. Evans, B.Sc., F.R.I.C.; W. Kwantes, M.A., M.B., B.Chir., Dip. Bact.; D. C. Jenkins, B.Sc., M.Sc., F.R.I.C.; & J. I. Phillips, F.R.I.C.

Institution of Chemical Engineers

Birmingham: Midlands Institute, 3 p.m.
'The Performance Characteristics of 6 inch

Diameter Stedman Packing Under Reduced Pressures. Parts One & Two' by D. G. Cerigo, B.Sc., Ph.D.; P. J. King, B.Sc.; & Professor F. Morton, D.Sc., Ph.D., F.R.I.C.

Market Reports

LONDON.—Trading conditions on the chemicals market have remained active throughout the week and there has been fair pressure for deliveries against contracts. Buying interest for shipment continues to be well maintained and the current movement on export account is in excess of the corresponding period of a year ago. The price position generally is firm and higher where changed. Copper sulphate is dearer at £118 15s per ton while the basis prices for white lead and red lead have been advanced as from 30 November: dry white lead £145 15s per ton, dry red lead £140 10s per ton and litharge £142 10s per ton. Activity on the coal tar products markets remains brisk with home and export demand for the creosote oils and for the cresylic acids on a satisfactory scale. Pitch is moving well as also is refined tar.

MANCHESTER.—A fairly steady demand for textile chemicals from Lancashire and West Yorkshire consumers has been reported on the Manchester market during the past week, with a good flow of contract delivery specifications from most other industrial outlets. A fair number of additional inquiries from both home consumers and shippers have also been reported. The undertone remains steady to firm pretty well throughout the range, the outstanding change being a further stiffening in the quotations for sulphate of copper. Taking the fertilizer section as a whole business has been on a moderate scale. A steady demand for most of the coal-tar products continues to be reported.

GLASGOW.—The general trend during the past week in the Scottish heavy chemical market has been of reasonable activity. Deliveries against contracts are being well maintained, while spot deliveries are covering quite a large and varied range of chemicals. On the agricultural side the demand has been steady, with emphasis on forward bookings for the coming season. Prices on the whole have remained steady. The export market still continues active, and a fair volume of orders has been received.

ION EXCHANGE MATERIALS

Ion Exchange today performs many tasks in industry, and Permutit manufactures a wide range of these materials. Their application in roles distinct from water treatment has resulted in the development of numerous new industrial processes giving improved results and lower running costs. Some of the materials now available, with their characteristics, are shown below.

ZEO-KARB Na A sulphonated coal product containing both strong and weak acid groups.

ZEO-KARB 215 A nuclear sulphonated phenol resin containing also hydroxyl groups.

ZEO-KARB 225 A unifunctional cross linked sulphonated polystyrene resin in bead form of high capacity and exceptional chemical and physical stability.

ZEO-KARB 226 A unifunctional cross linked methacrylic acid resin in bead form containing only carboxyl groups as the ion active groups.

DE-ACIDITE E A high capacity anion exchange material of medium basicity.

DE-ACIDITE FF A unifunctional very highly basic anion exchange resin in bead form based on cross linked polystyrene and containing quaternary ammonium groups.

DE-ACIDITE G A unifunctional weakly basic exchange resin in bead form based on cross linked polystyrene and containing diethylamino groups.

DE-ACIDITE H A material similar to "De-Acidite G" but containing dimethylamino groups.

BIO-DEMINROLIT A mixed cation and anion exchange resin for demineralisation in a single column.

DECALSO F A synthetic sodium aluminium silicate suitable for the separation and concentration of vitamins and hormones.

DECOLORITE-

ASMIT A resin of high porosity for removing colour from solutions.

PERMAPLEX C-10 A highly selective cation exchange resin membrane containing SO_3H groups.

PERMAPLEX A-10 A highly selective anion exchange resin membrane containing quaternary ammonium groups.

For full technical information please write to:—

THE PERMUTIT COMPANY LIMITED

Dept. V.A. 150, Permutit House, Gunnersbury Ave., London, W.4. Tel: CHIswick 6431

CLASSIFIED ADVERTISEMENTS

SITUATIONS VACANT

The engagement of persons answering these advertisements must be made through a Local Office of the Ministry of Labour or a Scheduled Employment Agency if the applicant is a man aged 18-64 inclusive, or a woman aged 18-59 inclusive, unless he or she, or the employment, is excepted from the provisions of the Notifications of Vacancies Order, 1952.

CHEMIST and/or PHYSICIST
are required by the
UNITED KINGDOM ATOMIC ENERGY AUTHORITY,
Industrial Group Headquarters,
RISLEY,
nr. Warrington,
for work in the Technical Policy Branch.

Post (a) (Technical Sales Section), **CHEMIST** or **PHYSICIST** (reference 1,191) to lead a team involved in overseas sales of special atomic energy materials and equipment.

Candidates should have a good Honours Degree in Chemistry or Physics, and should have had industrial or commercial experience. A working knowledge of several European languages would be an advantage. Salary, £1,490 to £1,685 per annum.

Post (b) (Commercial Section), **INDUSTRIAL CHEMIST** (reference 1,192).

Candidates should have an Honours Degree in Chemistry or Chemical Engineering or equivalent qualifications. They should have had several years' industrial experience on chemical production and be capable of making critical assessments of essential items of process technology.

Salary, £1,130 to £1,435 per annum.

Post (c) (Technical Sales Section), **CHEMIST ENGINEER** (reference 1,193), to assist in negotiating for the production and sale of atomic energy materials and equipment.

Candidates should have a good Honours Degree in Chemistry or Chemical Engineering, and should have had industrial or research experience.

Salary, £1,130 to £1,435 per annum.

For Posts (a) and (b) some travelling will be involved and opportunities will be provided to acquire familiarity with the specialised processes of Atomic Energy.

The Authority's Superannuation Scheme includes widows, dependants and retirement benefits.

Send for application form to:

RECRUITMENT OFFICER,
U.K.A.E.A. INDUSTRIAL GROUP HEADQUARTERS,
RISLEY, NR. WARRINGTON,
quoting the appropriate reference.
Closing date, 16th December, 1955.

SENIOR RESEARCH CHEMIST

British Enka Limited, Rayon Yarn Producers, require a Senior Research Chemist to take charge of group. Minimum qualifications Ph.D., preferably with research experience. Commencing salary £1,000 to £1,500 per annum. Good prospects. Pension scheme. Applications, which will be treated in confidence, should state age, qualifications, details of experience and be addressed to Personnel Manager, British Enka, Ltd., Aintree, Liverpool, 9.

RESEARCH CHEMISTS

Chemists required by progressive Rayon Yarn Producers for Research and development work. Applicants should be honours graduates preferably with research experience. Good salaries, prospects and pension scheme. Applications, which will be treated in confidence, should state age, qualifications, details of experience, present salary and be addressed to Personnel Manager (R) British Enka, Ltd., Aintree, Liverpool, 9.

NORTH THAMES GAS BOARD

invites applications from

CHEMISTS

who have obtained a First or Second Class Honours Degree, for vacancies at its Chemical By-Products Works, Beckton, East Ham, E.6., for research on problems in connection with coal tar distillation, and the manufacture of phenols, naphthalene and bases.

Preference will be given to those who have had some post-graduate experience in research, particularly in subjects related to those mentioned above.

These are permanent appointments and offer good prospects of advancement.

Successful candidates will be required to join the Staff Pension Scheme. Starting salaries will be according to age and qualifications.

Applications, giving age and full details of training and qualifications, should be addressed to

THE STAFF CONTROLLER,

NORTH THAMES GAS BOARD,
30, KENSINGTON CHURCH STREET, W.8,
to reach him by not later than 14 days after the publication of this advertisement, quoting reference 666/288.

ATOMIC POWER

CHEMISTS wishing to work in this new field are invited to apply to 'ENGLISH ELECTRIC,' who have senior and junior vacancies at their Whetstone establishment. Write for further information or submit applications to Dept. C.P.S., 336-37, Strand, W.C.2, quoting Ref. 1367E.

DRAUGHTSMEN

VACANCIES for Draughtsmen with experience in the following fields:—

- Heavy Plant Work
- Mechanical Handling
- Structural Steel

Working conditions and scope good. Five-day week, 3 weeks' holiday, luncheon facilities, Pension Scheme. Initial salaries depending on age and experience, up to £800 per annum for senior men.

Write

STAFF DEPARTMENT,
HUNTINGTON, HEBERLEIN & CO., LTD.,
114, CROMWELL ROAD,
LONDON, S.W.7.

GRADUATES in **MECHANICAL** and **CHEMICAL ENGINEERING** required for progressive positions in the Research, Design and Production Divisions of **THE POWER-GAS CORPORATION LIMITED**. Training given to men without previous industrial experience. Apply to:—**STAFF PERSONNEL MANAGER, PARK-FIELD WORKS, STOCKTON-ON-TEES.**

IMPERIAL SMELTING CORPORATION, LIMITED, has a vacancy in Development Department for a **GROUP LEADER**, Instruments (Investigations). This is a new appointment and will involve visiting all works in the Organisation to examine the possibility of the extension and introduction of instrumentation on different plants and processes and in addition supervising a team carrying out special measurements on the Avonmouth site. Candidates should possess a Degree, preferably in Electrical Engineering, Physics or Chemical Engineering, or an equivalent professional qualification and should have had at least two years' experience of work in either instrument development or instrument manufacture. Details to Personnel Manager, Imperial Smelting Corporation, Limited, St. Andrew's Road, Avonmouth, Bristol, quoting Reference GLI/CA.

SITUATION WANTED

ENGINEER, 31, qualified. Works D.O. development, erection and maintenance, used to strict control labour and costs, seeks post Chemical/Food Industry, Manchester area preferred. Salary, £1,000 per annum. **BOX No. C.A. 3442, THE CHEMICAL AGE, 154, FLEET STREET, LONDON, E.C.4.**

FOR SALE

CHARCOAL, ANIMAL AND VEGETABLE horticultural, burning, filtering, disinfecting, medicinal, insulating; also lumps ground and granulated; established 1830; contractors to H.M. Government.—**THOS. HILL-JONES, LTD., "INVICTA" WORKS, BOW COMMON LANE, LONDON, E. TELEGRAMS: "HILL-JONES, BOCHURCH LONDON." TELEPHONE: 8285 EAST.**

MORTON, SON AND WARD, LIMITED,
offer

BROADBENT HYDRO EXTRACTORS

- 8** New 36 in. diam. galvanised baskets, electrically driven through centrifugal clutch. Safety interlocks.
- 6** New 36 in. diam., same as above but belt driven.
- 10** New 21 in. diam. galvanised baskets, electrically driven through centrifugal clutch. Safety interlocks.
- 8** New 21 in. diam., same as above but belt driven.
- ALL THE ABOVE ARE STILL PACKED IN MAKER'S ORIGINAL CASES AND ARE ON OFFER AT UNREPEATABLE PRICES.**

MIXERS

- New "**MORWARD**" "U" shaped Vessels made to requirements in stainless steel or mild steel. Jacketed or unjacketed, with or without mixing gear.
- 50** 100g. Heavy Duty **MIXERS** by **FALLOWS** and **BATES**, agitators driven through bevel gears from fast & loose pulley.

JACKETED PANS

NEW 100g., 150g. and 200g. in mild steel for 100 lb. w.p., with or without mixing gear.

SECOND-HAND PANS, MIXERS, etc., available from stock—all in good condition.

PUMPS

A selection of new **MONO** and other second-hand **PUMPS** in stock, 2 in. to 5 in.

MORTON, SON AND WARD, LIMITED,
WALK MILL,
DOBCROSS, NEAR OLDHAM,
LANCS.

Phone Saddleworth 437.

PHONE 98 STAINES

- TWO** 27½ h.p. "**CARRIER**" **CENTRIFUGAL PUMPS**—6 in. suction.
- 1½** h.p. "**GWYNNE**" **GUNMETAL CENTRIFUGAL PUMPS**—8 in. suction, all 400/3/50.
- TWO** ENAMELLED **JACKETED ENCLOSED CYLINDRICAL MIXERS** by "Cannon"—30 in. by 36 in. deep, 440/3/50.
- Three** **COCHRAN BOILERS**—2,600, 1,000 & 850, evap. 100 w.p.
- 500 & 2,000 gal. JACKETED LITHCOTED CYLINDRICAL ENCLOSED TANKS.**
- 2,300 gal. GLASS-LINED CYLINDRICAL ENCLOSED TANK.**
- "**Z**" **FIN & CYLINDRICAL MIXERS.** Stainless steel mixing arms.
- AUTOCLAVES, OVENS, GRINDERS, PULVERISERS, STEAM & DIESEL PLANT, etc.**
- HARRY H. GARDAM & CO., LTD., STAINES.**

600**DRYING PLANT, FURNACES & OVENS**

- ROTARY** Kiln by Krupp, 197 ft. by 9 ft. 10 in. i.d., construction ¾ in. plate, lined 9 in. thick alumina brick, 4 roller paths. Drive by 120 h.p. Brook slipring **MOTOR** 400/3/50, through reduction gear and 3 sets open gears to girthing gear.
- ROTARY OIL-FIRED KILN** by Edgar Allen—53 ft. by 6 ft. 7 in. diam., riveted steel construction. Drive through girthing gear from 24 h.p. slipring induction **MOTOR** 400/3/50, through Radicon reduction gear. Accessories include kiln with feed and retractable firing hoods mounted on four bogies and track, cyclone 12 ft. on straight by 8 ft. diam.
- CALCINING KILN** by E. Newell—25 ft. by 39 in. diam., riveted steel construction, diesel oil fired. Driven by totally enclosed Brook slipring motor 400/3/50, through Croft reduction gear. Retractable firing and feed hoods.
- ROTARY COOLER**—22 ft. 9½ in. by 4 ft. 8½ in. diam., construction ¾ in. plate. Chain driven by 20 h.p. Brook slipring motor 400/3/50, through Radicon reduction gear.
- Rotary Oil-fired FURNACE** by Stein & Atkinson—mild steel construction, 8 ft. on straight, 50 in. outside diameter, conical ends 20 in. and 14 in. long. Furnace lined manganese bricks fitted retractable doors. Mounted on roller paths and motorized 400/3/50. Wallsend slipway burner, working temperature 210 deg. F. With Alcosa fan, cyclone, ducting and two cast-iron slag pots.
- Two Gas-fired DRYING OVENS**—each 44 in. by 34 in. by 64 in., with two hinged doors. Fitted 7 racks of tubular construction.
- OVEN** by Laboratory Thermal Equipment. Thermostatic control at 105 deg. C. with maximum 250 deg. C. Fitted two shelves 18 in. by 19½ in. with racks available for 5 shelves. Loading 2,250 watts for operation on 100/110/1/50. With transformer.
- GEORGE COHEN, SONS & CO., LTD.,**
WOOD LANE, LONDON, W.12.
Tel.: Shepherds Bush 2070, and
STANNINGLEY, NR. LEEDS.
Tel.: Pudsey 2241.

ONE S. J. WERNER MIXER with pan approx. 2 ft. by 2 ft. of the tilting type.

Two steam jacketed CAST-IRON FILTER PRESSES, each with 38 s.j. plates and 39 frames, cake size 2 ft. 4 in. square.

Several Johnson CAST IRON FILTER PRESSES—various sizes and types.

GARDNER MIXERS and Mixers and Sifters combined, sizes "B," "G," "H" and "I."

HYDRO EXTRACTORS, 24 in. 30in. and 36 in.

Two 18 in. KEK PLATE MILLS, with feeders, delivery bins, motors and entablature.

Two No. 4 SUPER MIRACLE MILLS with motors and starters.

Two Single effect EVAPORATORS by Scott with pumps and motors.

1 Gardner s.j. MIXER, trough 6 ft. by 3ft. by 3ft., complete with motor and reduction gear.

3 Copper Lined s.j. Pans, 60 lbs., pressure.

RICHARD SIZER, LTD., ENGINEERS, HULL.

Tele: 31743

FOR SALE—120 cu. ft. "**REAVELL**" Two Stage Water Cooled Air Compressor for pressures up to 450 lb. p.s.i. New and unused.

G. E. SIMM (MACHINERY) LIMITED,
27, BROOMGROVE ROAD, SHEFFIELD, 10.
Tel.: 64436.

ONE OVAL-SHAPED DISINFECTOR by Manlove & Allott. Inside measurements, 30 in. by 50 in. high by 7 ft. long, steam jacketed, with hinged door each end. 30 lb. p.s.i. pressure. £80. **THOMPSON & SON (MILL-WALL) LTD., LONDON, E.14 (TEL. EAST 1844).**

For Sale—continued

15 SULPHURIC Acid Tanks for sale, as removed from rail wagons. $\frac{3}{4}$ in. plate, welded construction. 15 ft. 6 in. long by 5 ft. diam. Manhole, etc. Excellent condition. **BOX No. C.A. 3441, THE CHEMICAL AGE, 154, FLEET STREET, LONDON, E.C.4.**

WANTED

INDUSTRIAL BY-PRODUCTS, LTD., 16, Philpot Lane, London, E.C.3, will be pleased to receive particulars of any by-products, waste materials and residues for disposal.

PROCESS SALVAGE, LTD., offer the highest prices obtainable in this country for 40/45-gallon bung type and full aperture **STEEL DRUMS.** We are interested in purchasing any quantities of either type you may have available for disposal and can arrange for cash payments and immediate collections.— Please ring Advance 1676 (four lines) or write **PURCHASING DEPARTMENT, PROCESS SALVAGE, LTD., 79/83 COBORN RD., BOW, LONDON, E.3.**

WORK WANTED & OFFERED

CRUSHING, GRINDING, MIXING and DRYING for the trade.

THE CRACK PULVERISING MILLS LTD
Plantation House,
Mining Lane,
London, E.C.2.

PULVERISING of every description of chemical and other materials for the trade with improved mills, wharfrage, and storage facilities. **THOS. HILL-JONES, LTD., "INVICTA" WORKS, BOW COMMON LANE, LONDON, E.** TELEGRAMS: "HILL-JONES, BOCHURCH LONDON." TELEPHONE: 3285 EAST.

PATENT

THE Proprietors of Patent No. 593768, for "IMPROVEMENTS IN OR RELATING TO THE PRODUCTION OF CELLULOSE," and No. 597379, for "METHOD FOR THE PREPARATION OF PURIFIED CELLULOSE," desire to secure commercial exploitation by licence in the United Kingdom. Replies to Haseltine Lake & Co., 28, Southampton Buildings, Chancery Lane, W.C.2.

AUCTIONEERS, VALUERS, Etc.

EDWARD RUSHTON, SON AND KENYON
(Established 1855).

Auctioneers, Valuers and Fire Loss Assessors of
CHEMICAL WORKS PLANT AND MACHINERY

York House, 12 York Street Manchester.

Telephone 1937 (2 lines) Central Manchester.

**For Classified Advertising
THE CHEMICAL AGE
PULLS IN RESULTS**



The crank shaft is the heart of the engine; lubricating oil its heart's blood. Stream-Line filters enable first grade oil to be used over and over again, increasing efficiency and effecting a big saving in overhauls and maintenance.

Over 50,000 users prove the value of Stream-Line filters in the economical operation of i.c. engines.

STREAM-LINE FILTERS

MAKE OIL LUBRICATE
LONGER

STREAM-LINE FILTERS LTD

INGATE PLACE, LONDON, S.W.1. TEL.: MACAULAY 1011

**FOR ALL TYPES OF BOILERS**

Durability
Efficiency

Patents
207123
490306
581396

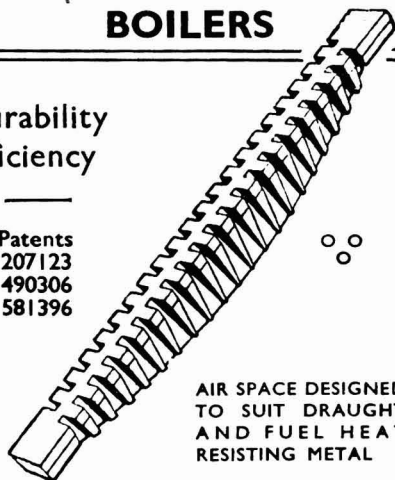

AIR SPACE DESIGNED
TO SUIT DRAUGHT
AND FUEL HEAT
RESISTING METAL

COLLINS IMPROVED FIREBARS, LTD.

51, THE MALL, EALING, LONDON, W.5
T N. Ealing 4070

TANTIRON

*pipes, vessels & fittings
for handling Corrosives*

Tantiron, the registered trade name applied to Silicon iron castings, was first cast and produced on a commercial scale by The Lennox Foundry Co. before 1910, so we are well justified in our claim that it is the first—and still the best—high silicon resisting iron.

Tantiron is manufactured into Pumps, Valves, Dephlegmators, Pipes, Cocks, Absorption Towers, Pans, Reaction Vessels, Coolers, etc.

Tantiron resists most of the known persistent corrosive agents. Tantiron Pipes, Valves and Fittings are subject to a hydraulic test before despatch and test certificates furnished when requested.

S I L I C O N I R O N

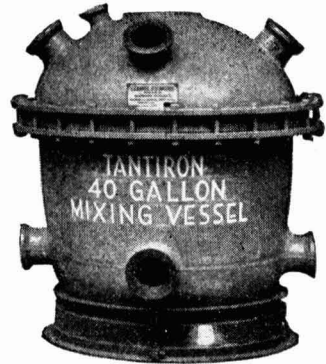

LENNOX FOUNDRY CO., LTD.,
Tantiron Foundry, Glenville Grove, London, S.E.8.

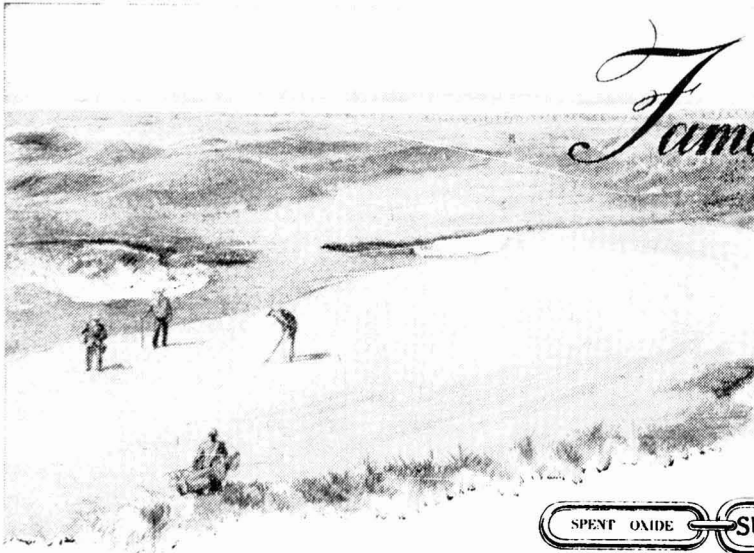

Famous Links

*Staveley Chemicals
are the "Links"
between raw materials
and finished products
in industry.*

The 7th Green
at Royal St.
George's Golf
Links, Sandwich,
Kent.



**BASIC CHEMICALS
FOR INDUSTRY**

THE STAVELEY IRON & CHEMICAL CO. LTD.

NR. CHESTERFIELD

INDEX

to advertisers in this issue

	Page
Ancorite Ltd.	1233
Benjamin Electric Ltd.	1191
Beryllium & Copper Alloys Ltd.	1200
British Lead Mills Ltd.	1231
British Thomson-Houston Co., Ltd. (The)	1192
Cementation Co. Ltd. (The)	1184
Classified Advertisements	1238, 1239, 1240
Collins Improved Firebars Ltd.	1240
Darnley, Taylor, J. Ltd.	1184
Eimco, Ltd.	1185
Fawcett-Finney Ltd.	1187
Gallenkamp & Co., Ltd.	1195
I.C.I. Ltd. (Paper Goods Manufacturing Co., Ltd.)	1194
Industrial & Marine Protective Applications Ltd.	1197
James, A. Jobling & Co., Ltd.	1242
Kestner Evaporator & Eng. Co., Ltd.	1199
Key Engineering Co., Ltd. (The)	Cover ii
Leda Chemicals Ltd.	1193
Lennox Foundry Co., Ltd.	1241
Lord, John, L.	Cover iv
Marchon Products Ltd.	1183
Meigh Castings Ltd.	1199
Metafiltration Co., Ltd. (The)	1196
Metropolitan-Vickers Electrical Co., Ltd.	Cover iv
Mills Pickard Construction Ltd. (The)	1186
Mond Nickel Co., Ltd.	1190
Moore, W. & E., Ltd.	1197
Morgan Crucible Co., Ltd. (The)	Cover iii
Moritz Chemical Engineering Co., Ltd.	1196
National Enamels Ltd.	Cover ii
Pascall Engineering Co., Ltd. (The)	1235
Permutit Co., Ltd. (The)	1237
Price Stutfield & Co., Ltd.	Front Cover
Prodorite Ltd.	1198
Pulsometer Engineering Co., Ltd. (The)	1202
Rozalex Ltd.	1197
Siëbe Gorman & Co., Ltd.	1198
Staveley Iron & Chemical Co., Ltd. (The)	1241
Streamline Filters, Ltd.	1240
Wallach Bros., Ltd.	1199
Walley, A. L.	1202
Ward, Thos. W., Ltd.	1189
Wells, A. C. & Co., Ltd.	Cover ii
Wilkinson Rubber Linatex Ltd.	1188
Zeal, G. H., Ltd.	1235

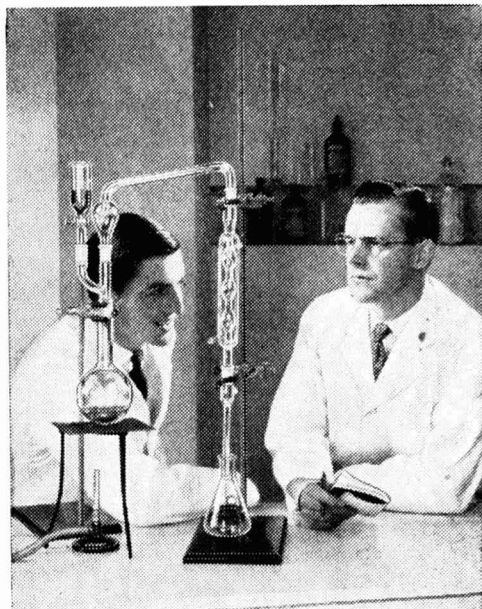

'That's a neat bit of Bench Assembly!' . . .

' . . . YES, I agree with you, and the reason it is so neat is because of the interchangeable ground glass joints. It's 'PYREX' of course, and the specially strengthened 'Grip-Seal' joints not only save time in assembling, but also ensure accurate fitting and less likelihood of breakage.'

' 'Grip-Seal,' what a perfect description!'

'It is indeed, and it's even more than that! Every joint fits perfectly and makes a perfect seal for both gas and moisture. We never have any leakage troubles, and that's a great help in our distillation experiments.'

- The advantages of 'PYREX' 'Grip-Seal' Joints are described fully in the new 'PYREX' catalogue, which contains also many examples of complete Assemblies made up with 'Grip-Seal' Joints.

- If you would like a copy of this 124-page reference book, we will gladly send it. Any special Assemblies not listed can be fabricated to your own ideas or needs by technicians well skilled in development work of this nature.



JAMES A JOBLING & CO LTD
Wear Glass Works Sunderland

REGD. TRADE MARK

THE ONLY MAKERS OF 'PYREX' BRAND GLASS IN THE UNITED KINGDOM

CARBINERT (IMPERVIOUS GRAPHITE) FOR THE CHEMICAL AND PROCESS ENGINEER

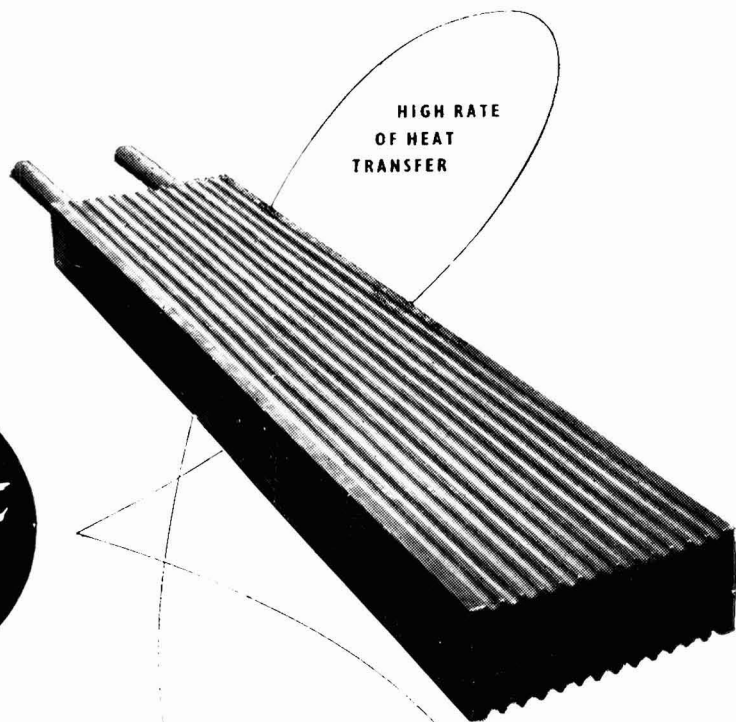

The
Carbinert
Plate
Heater

The Carbinert Plate Heater is of a sturdy construction capable of withstanding internal steam pressure of 40 lb/in². This type of plate heater is being adopted extensively for heating all kinds of chemical vessels and is particularly suited for use in steel pickling baths.

CARBINERT (Impervious Graphite) is a robust material with a high rate of heat transfer and has an exceptional resistance to most acids and alkalis. Write for Booklets P.9 and 16 giving further details of its uses.

EXCEPTIONAL
RESISTANCE
TO MOST
ACIDS & ALKALIS

THE **MORGAN CRUCIBLE** COMPANY LIMITED



*See at a glance
with a*

N.B.

Available in the standard ranges of 0 to 0.5, 0 to 1.5 or 0 to 3 inches of water. Other ranges can be supplied if required.

Length 7 inches

Depth $3\frac{1}{4}$ inches

Send for leaflet E.S. 4352/1

This low-priced easily installed instrument—something entirely new on the market—makes the routine inspection of air-conditioning filters quick and easy. The ordinary method of withdrawing each cell for visual inspection is time-wasting and laborious, cells in good condition often being needlessly removed. With the Filtometer permanently fitted across the filter battery the need for cleaning can be judged by a glance at the dial pointer.

A valuable feature is the finger operated spring-return valve which safeguards the indicator from being clogged with dust, the valve being open only when a reading is being taken.

METROPOLITAN-VICKERS ELECTRICAL CO LTD, TRAFFORD PARK, MANCHESTER 17

Member of the A.E.I. group of companies.

G/V 202

"STILL LEADING"

For CHEMICAL & ALLIED TRADES

**For PICKLING TANKS, FLOORS,
DIGESTERS, KIERS,
STONE, CONCRETE,
BRICK, WOOD,
IRON VESSELS
& ACID
TOWERS**

RIZISTAL

RESISTS

**Formaldehyde,
Alcohol, Oils, Greases
and Tar Acids, Benzene
Toluene Compounds HCl
H₂SO₄, HNO₃, and H₃PO₄,
mixed HNO₃ and HF Acids,
Aqua Regia, Formic, Acetic, Lactic
Oxalic, Chromic Acids, Bisulphites,
Hypochlorites, Mixed Acids, Per-
oxides, Nascent Halogens and Alkalies.
UNDER STEAM PRESSURES**

SOLE MAKER OVER 50 YEARS' EXPERIENCE