

THE Chemical Age

VOL. LXXIV

5 MAY 1956

No. 1921

Britain's Largest

Continuous Tar Acids Distillation Plant

THIS PLANT for the continuous distillation of crude tar acids at the Beckton by-products works of the North Thames Gas Board was designed and erected by APV. It is the largest of the five continuous Tar Acid plants to be installed in this country, four of which have been constructed by APV.

Based on a crude feed of 350 g.p.h. and using steam only as the heating medium, the Beckton plant yields first-run products to the following specification:—

PHENOL	Crystallising point 40°C. (Min.)
o-CRESOL	93%
m.p.-CRESOL	55% m-Cresol
XYLENOLS	Boiling range 212-250°C.
PITCH	Viscosity 80°C. ring and ball

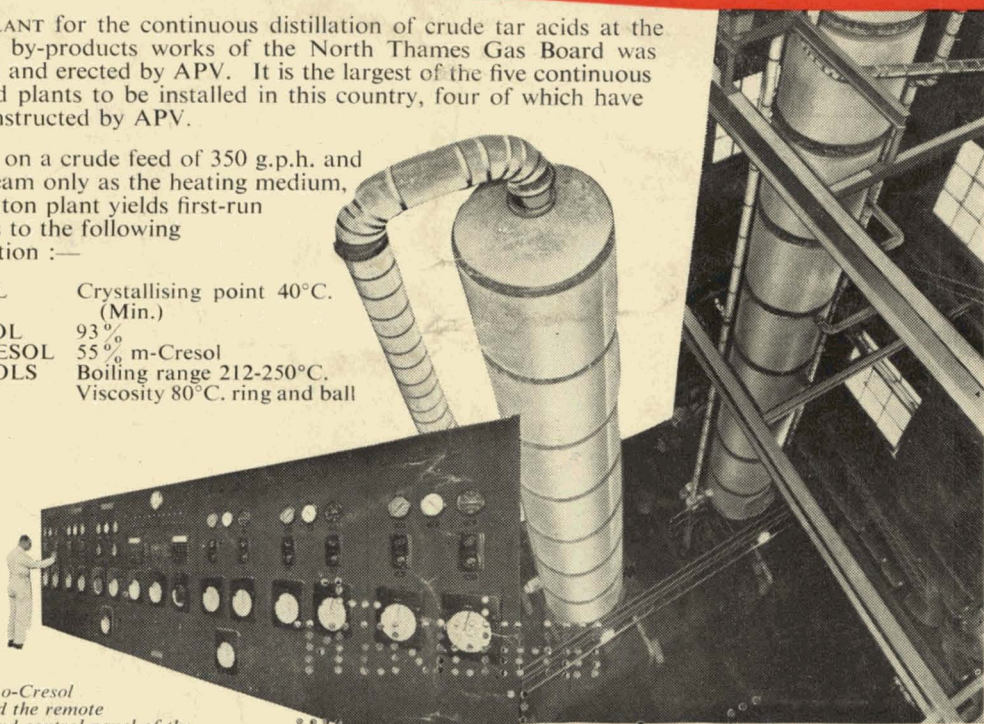

Phenol and o-Cresol columns and the remote recording and control panel of the Beckton Plant.

THE A.P.V. COMPANY LIMITED

Chemical Engineering Division, Wandsworth Park, London, S.W.18
Telephone: Vandyke 4492. Telegrams: Chapvem, Wesphone, London.

APV

PROCESS ENGINEERS AND CONSTRUCTORS TO THE CHEMICAL INDUSTRY

CRUICKSHANK'S

COPPER CARBONATE

We have perfected a special method of making this material, giving a very pure product.

The copper content is high—53/55%—and the impurities are very small.

It is specially ground to 200 mesh, thus enabling it to be used for floriculture in spraying machines if required.

R. CRUICKSHANK LTD.

CAMDEN STREET BIRMINGHAM, 1

Telephone : B'ham Central 8553 (6 lines)

Telegrams & Cables : Cruickshank Birmingham

Drying Trays

- IN HARD RESISTANT VITREOUS ENAMEL
- SPECIALLY PROCESSED TO GIVE MAXIMUM SERVICE
- ALL CORNERS AND EDGES ROUNDED
- SIZES TO SUIT CUSTOMERS REQUIREMENTS
- FINISHED IN GREEN OR OTHER SELECTED COLOUR

NATIONAL ENAMELS LTD.
53, NORMAN ROAD, GREENWICH
LONDON, S.E.10.

Telephone : Greenwich 2266-7 and 2429

**“REDAC”
PRODUCTS**



**ACID
RESISTING
EARTHENWARE**

**ACID RESISTING TILES · BRICKS
ACID TOWER PACKINGS
RINGS AND BALLS**

Successfully used in

**GAILLARD TOWERS · ACID OIL SETTLING TANKS
GAS WASHERS · CHIMNEY LININGS · ASH SLUICES
HYDROCHLORIC PICKLING TANKS, ETC.**

PRACTICALLY INDESTRUCTIBLE, CHEAPER & SUPERIOR TO LEAD AND OTHER MATERIALS

Enquiries Welcomed

B. WHITAKER & SONS, LTD.
ST. STEPHENS HOUSE, WESTMINSTER

Phone :
Whitehall 3616

Works : ACCRINGTON, LANCS.

Grams :
Bricavity, Parl, London

BROTHERHOOD

Air, Gas and Refrigerating
Compressors

For the manufacture of
ARTIFICIAL FERTILISERS and other **CHEMICALS**

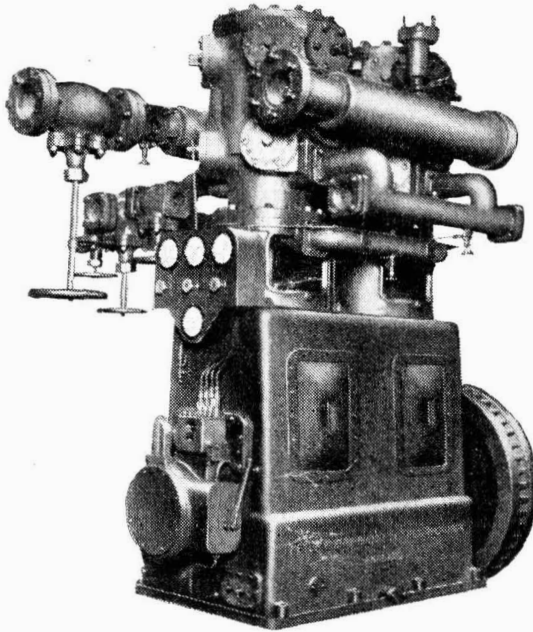

Also
STEAM TURBINES
GENERATING SETS

Literature describing Brotherhood Products available on request

 **PETER BROTHERHOOD**
PETERBOROUGH ENGLAND
COMPRESSOR & POWER PLANT SPECIALISTS FOR NEARLY A CENTURY

Famous Links

Staveley Chemicals are the "Links" between raw materials and finished products in industry.

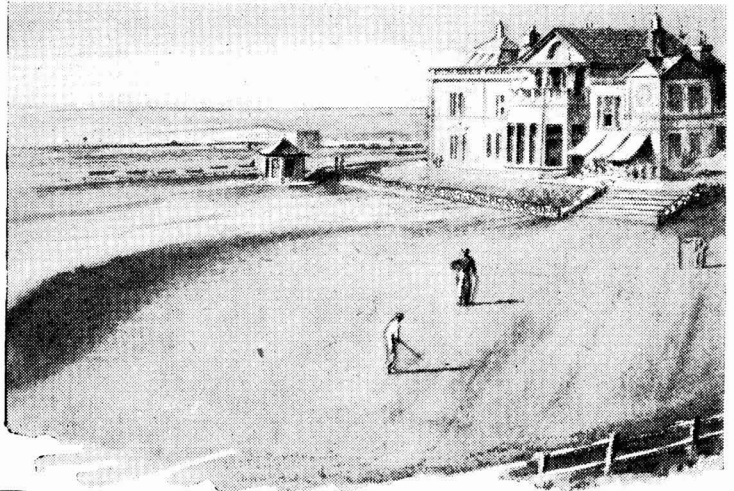

The Old Course
at St. Andrews.
A view of the
18th hole.



STAVELEY

BASIC CHEMICALS FOR INDUSTRY

THE STAVELEY IRON & CHEMICAL CO. LTD.

NR. CHESTERFIELD

PURE WATER

at low cost

NECKAR Ion
Exchange Plants
provide water of
distilled quality.

*Typical Plants employing
various methods . . . fully
described in our literature,
available on request.*

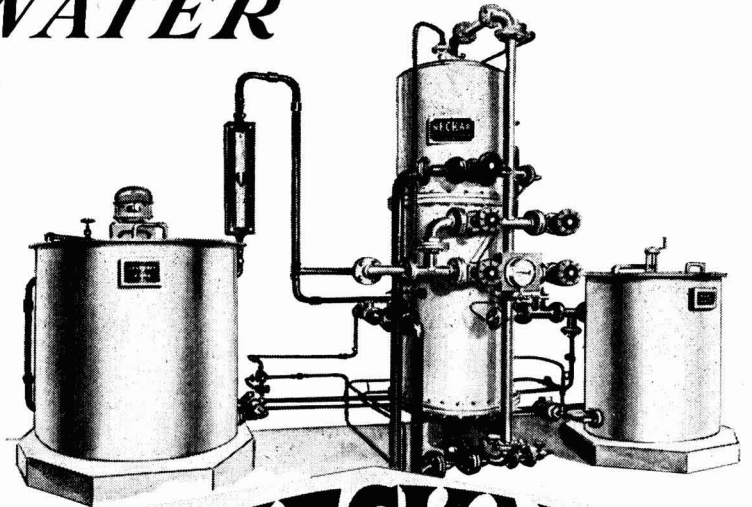

NECKAR

NECKAR WATER SOFTENER CO. LTD.

ARTILLERY HOUSE, ARTILLERY ROW, LONDON, S.W.1.



**IF IT'S AIR OR AIRBORNE
SPIRATUBE CAN DUCT IT**

Light materials or abrasive dust—acid fumes or combustion exhaust . . . it's a job for SPIRATUBE—the versatile flexible ducting that many leading industries are now specifying as standard equipment.

SPIRATUBE is installed quickly and easily with no costly structural alterations, heavy hangers or special fitments. Economical, too, because SPIRATUBE can be dismantled and used again and again. SPIRATUBE won't kink, or buckle, even when taken around sharp bends or along twisting passages. SPIRATUBE is light, tough, flexible, retractable and is available in a range of diameters from 3" to 30".

Write today for the SPIRATUBE Brochure which illustrates what this versatile ducting will do. Put your problem up to our Design Engineers. They will be glad to advise you without cost or obligation. The address is Flexible Ducting Limited, Maryhill, Glasgow.

FLEXIBLE DUCTING LIMITED, MARYHILL, GLASGOW, N.W.
Telephone: MARYhill 3729 Telegrams: Flexiduct, Glasgow, N.W.

AN ASSOCIATE COMPANY OF GEORGE MACLELLAN & CO. LTD

ESTABLISHED 1870

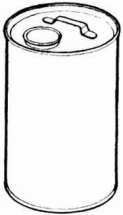

TYPE D.L.A.
For Oils and Paints.

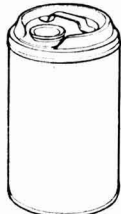

TYPE I.C.
Easy pouring for Paints and Oils.

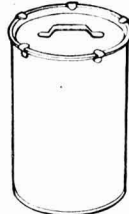

TYPE K.P.A.
For Pastes, Semi-Liquids and Powders.

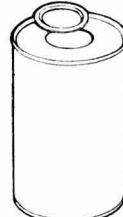

TYPE D.P.X.
For Chemicals, Powders, etc.

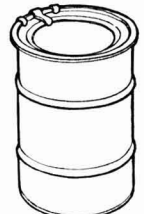

TYPE D.L.R./L.
Removable Lid—secured by closing band.

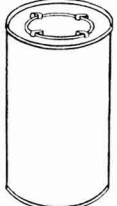

TYPE D.U.T.
For Greases, Powders and Pastes.

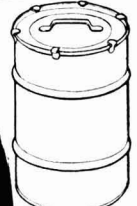

TYPE K.P.X.
For Pastes, Powders, etc.

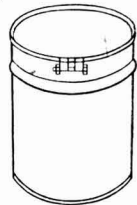

TYPE L.W.R.M.
Light-weight. Lid held on by closing band.

TODD
drums can
take it!

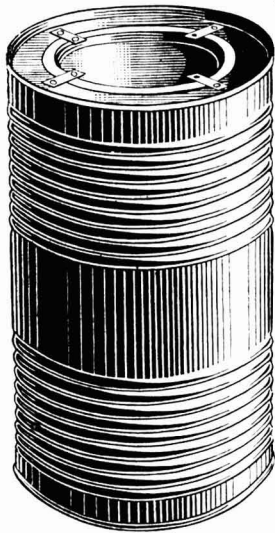

WHATEVER your product, there's a Todd drum to take it. A drum built to take punishment—to preserve the condition of your product from factory to user. TODD drums protect your reputation.

TYPE D.P.K.
Another of Todd's drums which are specifically designed for Chemicals. Various sizes of lids available.

TYPE D.L.R./L.
The drum for your product if you require a fully removable lid with quick acting hoop closure—easy to fill—easy to empty.

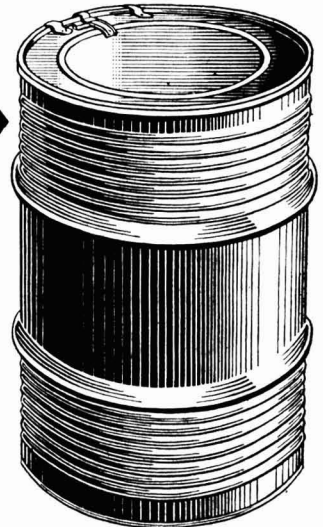

TODD
DRUMS AND KEGS

Send for complete list of drums and kegs to :—

TODD BROS. (ST. HELENS AND WIDNES) LTD., WIDNES, LANCs. Tel: Widnes 2267 (5 lines)



Ciech

Supplied by the Sole Exporters:—

“CIECH” Ltd.

Exporters and Importers of Chemical Products

12 JASNA STREET, WARSAW 10
POLAND P. O. BOX 343

Telegrams: Ciech, Warsaw Telephone 69001

ESSENTIAL OILS

Juniper Tar Oil

Oil of Dill

Oil of Peppermint

Oil of Pine

Oil of Siberian Fir

Oil of Calamus

Terpineol

Terpineol Acetate

GYP

SCREW-DOWN VALVES

FOR THE CHEMICAL INDUSTRY

Bodies in M.S.
Stainless Nylon
or PVC.

Sizes $\frac{1}{4}$ " to 1"
bore.

Supplied with or
without pipe
couplings.



Further details from

HIGH-PRESSURE COMPONENTS LTD

SUNFLEX WORKS

WEST DRAYTON, MIDDLESEX.

West Drayton 2226/7

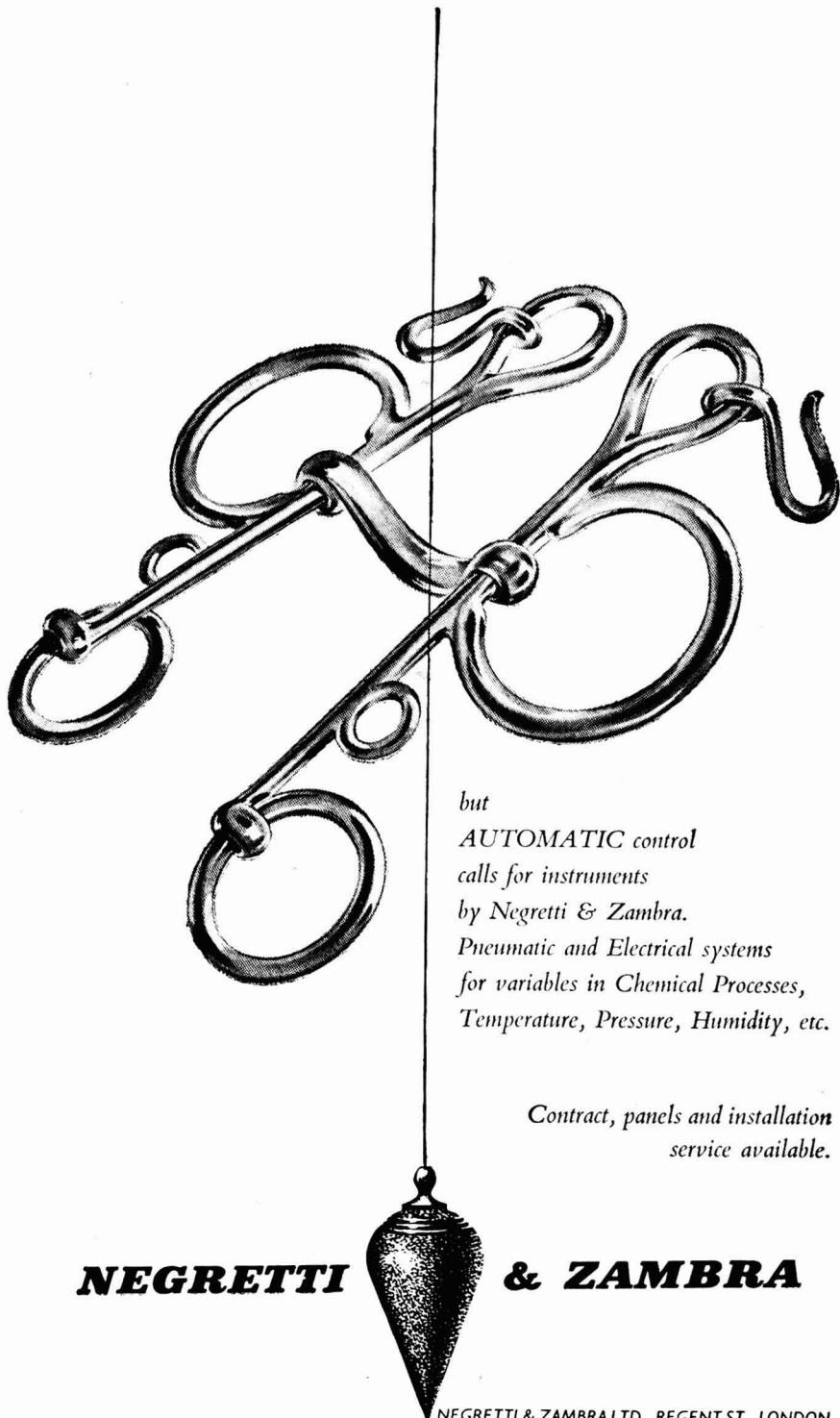

*but
AUTOMATIC control
calls for instruments
by Negretti & Zambra.
Pneumatic and Electrical systems
for variables in Chemical Processes,
Temperature, Pressure, Humidity, etc.*

*Contract, panels and installation
service available.*

NEGRETTI

& ZAMBRA

NEGRETTI & ZAMBRA LTD., REGENT ST., LONDON

BRABY (regd.)

STEEL DRUMS

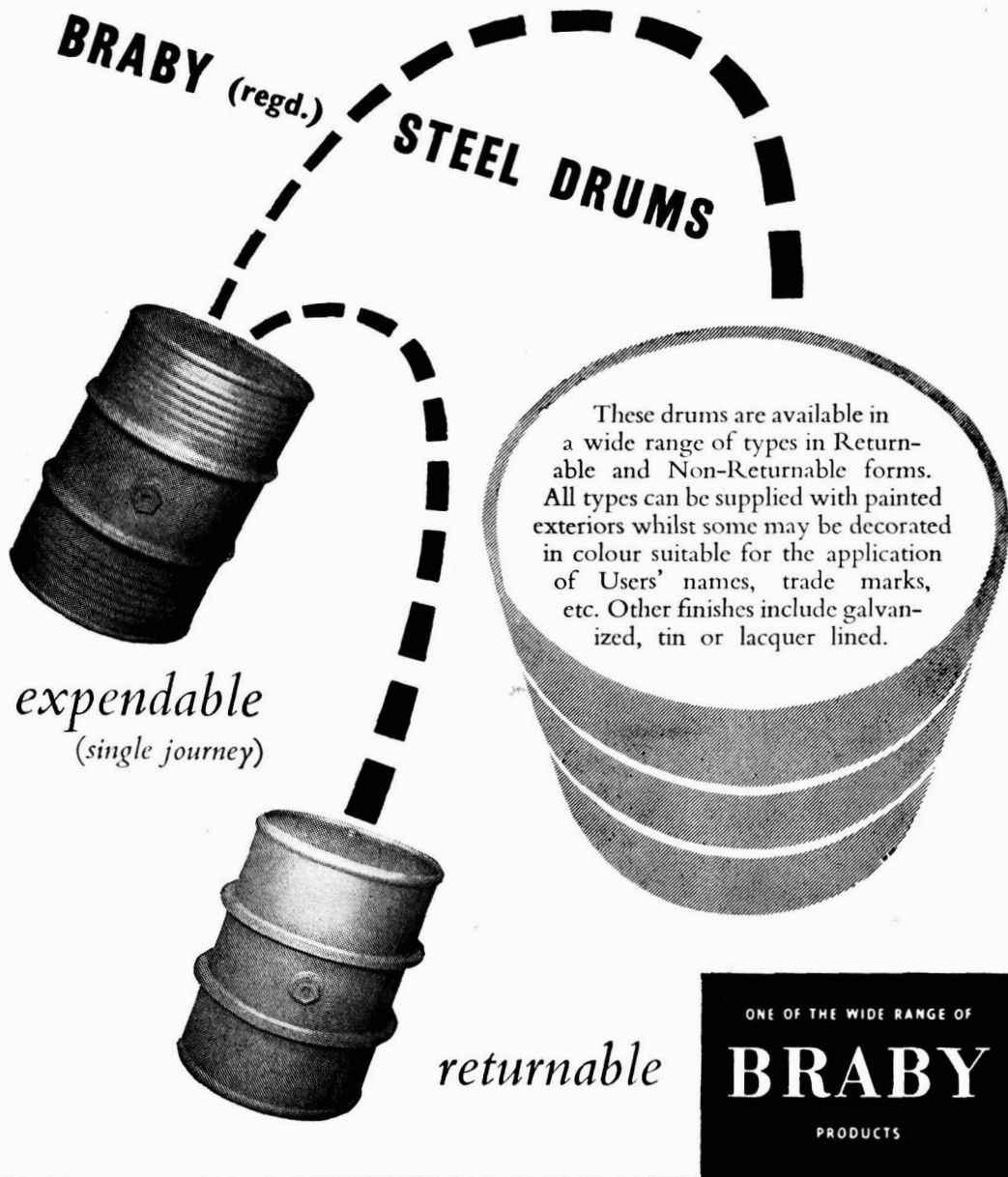

expendable
(single journey)

returnable

These drums are available in a wide range of types in Returnable and Non-Returnable forms. All types can be supplied with painted exteriors whilst some may be decorated in colour suitable for the application of Users' names, trade marks, etc. Other finishes include galvanized, tin or lacquer lined.

ONE OF THE WIDE RANGE OF
BRABY
PRODUCTS

FREDERICK BRABY & COMPANY LIMITED

HAVELOCK WORKS, AINTREE, LIVERPOOL, 10. TELEPHONE: AINTREE 1721

OTHER FACTORIES AT: London Works, Thames Road, Crayford, Kent. TELEPHONE: Bexleyheath 7777
Eclipse Works, Petershill Road, Glasgow, N. TELEPHONE: Springburn 5151
Ashton Gate Works, Bristol, 3. TELEPHONE: 64041. And Falkirk

OTHER OFFICES: 352-364 Euston Road, London, N.W.1 (Head Office). TELEPHONE: EUSton 3456
110 Cannon Street, London, E.C.4 (Export). TELEPHONE: MANsion House 6034
Queen's Buildings, 10 Royal Avenue, Belfast. TELEPHONE: 26509
Palace Street, Plymouth. TELEPHONE: 62261

SPECIAL ANNOUNCEMENT



WHIFFEN & SONS LTD

(INDUSTRIAL AND PHARMACEUTICAL CHEMICAL DIVISION OF FISON'S LIMITED)

TELEPHONE: PADDINGTON 1041 (5 LINES)
TELEGRAMS: WHIFFEN, NORTH WEST, LONDON
CABLES: WHIFFEN, LONDON

REGISTERED OFFICE
85, CARNWATH ROAD
FULHAM, LONDON

NORTH WEST HOUSE
MARYLEBONE ROAD
LONDON N.W.1

WHIFFENS ARE THE FIRST BRITISH FIRM
TO MANUFACTURE AND SUPPLY
ETHYLENE DIAMINE
IN COMMERCIAL QUANTITIES

... industrial
chemicals. In particular, new
derivatives of hydrazine, of which
we are the only manufacturers in
the United Kingdom, are becoming
of increasing industrial importance,
and plans are well advanced for ex-
panding production.

Amongst new products which will
be added to Whiffen's range I must
mention ethylene diamine, for
which a plant will shortly come on
stream. This versatile chemical has
previously been imported from
Germany and the United States and
is in demand as a raw material for
fungicides, pharmaceuticals, sur-
face coating agents, adhesives and
other uses.

... our
... new product "Im-
... the treatment of iron
... to which

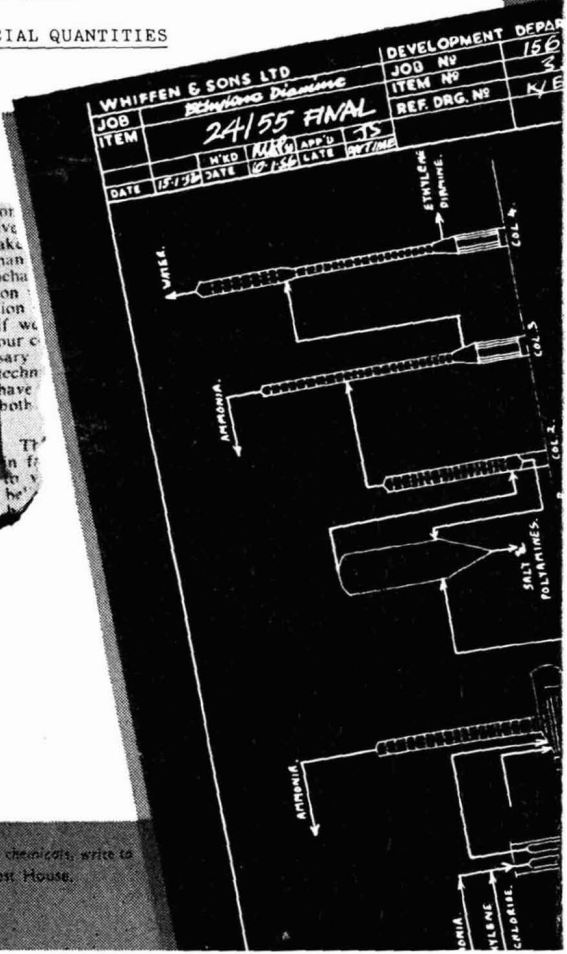

For samples and literature of this and many other fine chemicals, write to Whiffen & Sons Ltd., Dept. L/EDI, North West House, Marylebone Road, London, N.W.1

a new pump with a high resistance to sulphuric acid

For the first time an impressive list of acids, alkalis and slurries is opened up to economical pumping. The new features? construction in WORTHITE, a super-resistance alloy steel which will pump Sulphuric Acid with negligible corrosion loss, or in 18/8/3 Stainless Steel for handling corrosive liquids of a milder nature or where contamination and discolouration of the liquid must be avoided.

Also, easily interchangeable Mechanical Seals and Stuffing Box Packing to suit different processes — plus the simplicity of installation, longer life and cheaper costs which come with the Worthington-Simpson "Monobloc" construction.

Put it to the test

Write for
WORTHITE or 18/8/3
Stainless Steel $\frac{1}{4}$ "
Specimen Discs and
test these materials
under your own
site conditions

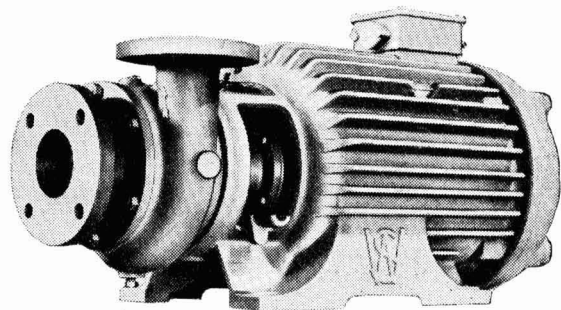

MONOBLOC CHEMICAL PUMPS

A WIDE RANGE AVAILABLE

WORTHINGTON - SIMPSON



WORTHINGTON-SIMPSON LTD NEWARK NOTTS

FINE CITRIC ACID IN THE MAKING



Sweet Beginnings

In considering Industry as Patron of the Arts, our new artist's attempt to illustrate the first stage in citric acid production is as irrelevant as it is original. That is what comes of mixing art with molasses, which is admittedly sweet—very sweet and also undeniably the beginning of the present Sturge Citric Acid story. But molasses has not always been the raw material of citric acid.

Formerly the industry relied entirely on imports of lemon juice and citrate of lime from Italy, but in 1930 Sturge introduced a new process for producing chemicals on a commercial scale by mould fermentation. This Sturge fermentation plant was the first of its kind to be operated in this country and finally enabled a by-product of home-grown sugar beet to replace imported materials.

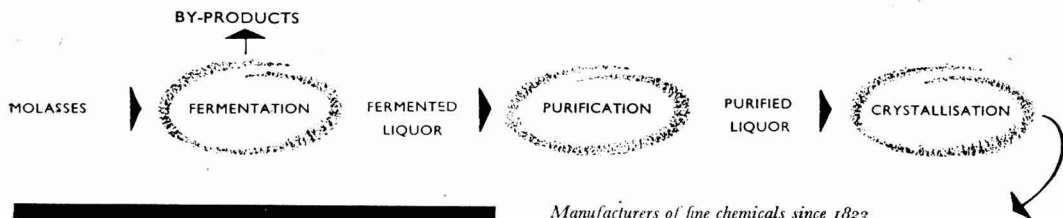

STURGE

Manufacturers of fine chemicals since 1823



**CITRIC ACID BP
CITRIC ACID ANHYDROUS**

FABRICATION

for the
**CHEMICAL
 INDUSTRY**

In the making of plant and equipment in cast iron and fabricated steel, Widnes Foundry and Engineering Co. Ltd., have served the industry for over a hundred years.

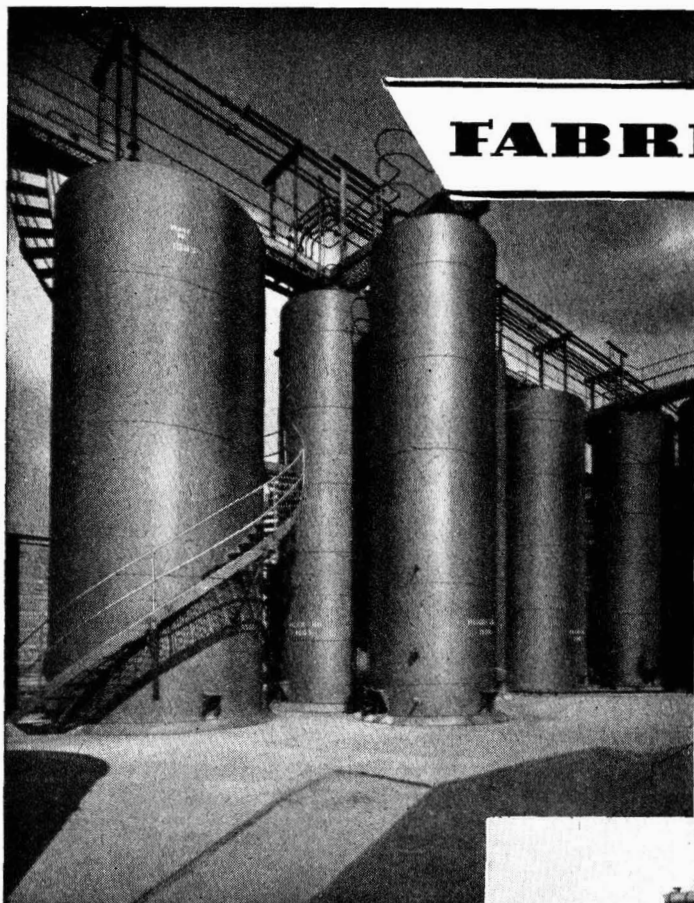

(above) Part of a battery of twelve mild steel storage tanks—the largest (of which there are four) being 12 ft. in diameter and 30 ft. high.

(right) Mild steel fractionating column, complete with condenser and battery of storage tanks; part of the plant supplied to Ashburton Chemical Works Ltd., a member of the Geigy Group of Companies.

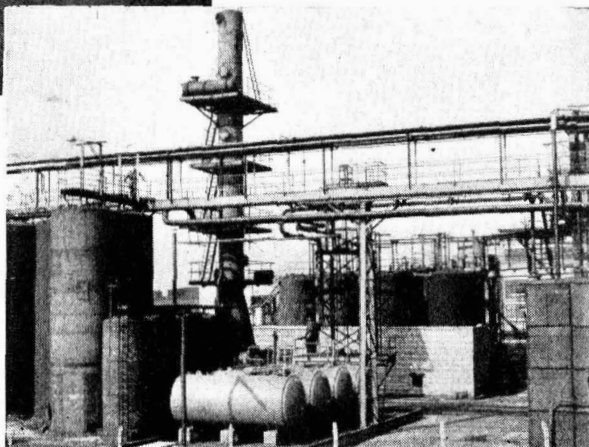

'Times' Photograph

ESTABLISHED 1841

wfe

**WIDNES FOUNDRY
 & ENGINEERING CO LTD**

LUGSDALE ROAD · WIDNES · LANCs

TELEPHONE: WIDNES 2251/4 · TELEGRAMS: "FOUNDRY · WIDNES"



IN THE SERVICE OF YOUR INDUSTRY

... with a range of products including ...

Para Cresol · Ortho Cresotinic Acid · Phenol ·
Phthalic Anhydride · Benzoic Acid · Salicylic
Acid (technical) · Meta Cresotinic Acid ·
Sodium Phenate

Write for full details to:

MONSANTO CHEMICALS LIMITED,

239 Victoria Station House, Victoria Street,
London, S.W.1, and at Royal Exchange, Manchester, 2.

*In association with: Monsanto Chemical Company, St. Louis, U.S.A.
Monsanto Canada Limited, Montreal. Monsanto Chemicals (Australia)
Ltd., Melbourne. Monsanto Chemicals of India Ltd., Bombay. Representa-
tives in the world's principal cities.*



Regd.

We are eager...

to serve your industry

BENZOPHENONE
COUMARIN
METHYL CINNAMATE
VANILLIN

BUSH

FINE CHEMICAL MANUFACTURERS

W. J. BUSH & CO. LTD. LONDON · E 8 · ENGLAND

Telephone : Clissold 1234

55/60

ECONOMY AND CONVENIENCE

in producing

HYDROGEN

and

OXYGEN

012 type
Electrolyser.
Capacity 10
cubic feet of
hydrogen
per hour.

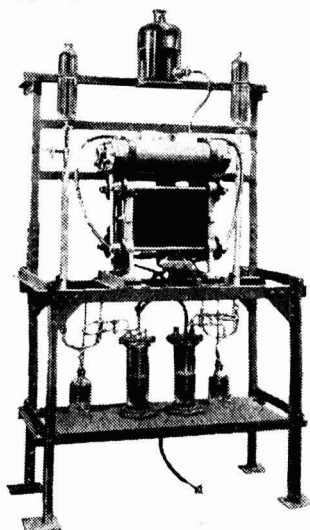

Modern industrial processes, with widely divergent end-products, frequently call for a steady supply of high purity hydrogen. This can readily be obtained by the electrolysis of water, giving at the same time by-product oxygen.

The compactness and ease of operation of the Bamag (1953) Limited electrolyser (designed as it is for the optimum utilisation of floor space), make it one of the most economical plants for this purpose.

Outputs from as little as 10 cubic feet per hour to as much as 17,000 cubic feet per hour can be obtained and within these limits, a single unit can be provided to suit specific requirements.

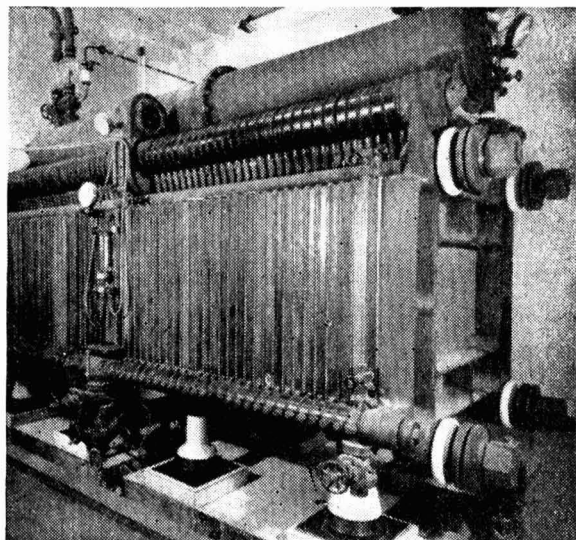

If the process calls for hydrogen, submit the problem to :

B60 Type Electrolyser. Capacity 2,800 cubic feet of hydrogen per hour.

COSTAIN-JOHN BROWN LTD

(Proprietors of Bamag (1953) Limited)

CHEMICAL ENGINEERS

ROXBY PLACE, LONDON, S.W.6 Telephone : Fulham 7761

SOLVENT EXTRACTION · DEODORISING · BLEACHING · REFINING · SULPHONATION
HARDENING · WINTERISING · GLYCERINE PROCESSING · ELECTROLYTIC HYDROGEN

COAL TAR BASES

TO MEET ALL SPECIFICATIONS

YORKSHIRE TAR DISTILLERS LTD
CLECKHEATON, YORKS.

TEL. CLECKHEATON
 790 (5 LINES)



TELEGRAMS TO -
 YOTAR CLECKHEATON



*Stainless Steel
 Holloware*

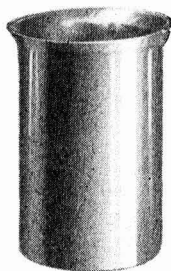
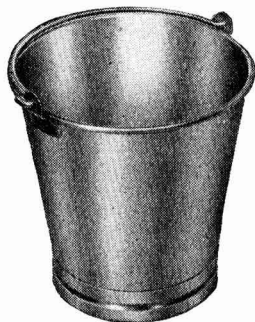

We are manufacturers of a wide range of holloware in stainless steel which finds use, because of its resistance to many forms of chemical attack, in dye works, chemical factories, food factories, laboratories and, because of its inherent cleanliness, in hospitals. Ask for our holloware leaflet.

The Taylor Rustless Fitting Co., Ltd.

Head Office · Ring Road, Lower Wortley, Leeds, 12.

London Office : 14, Great Peter Street, London, S.W.1

Leeds 638711

Abbey 1575

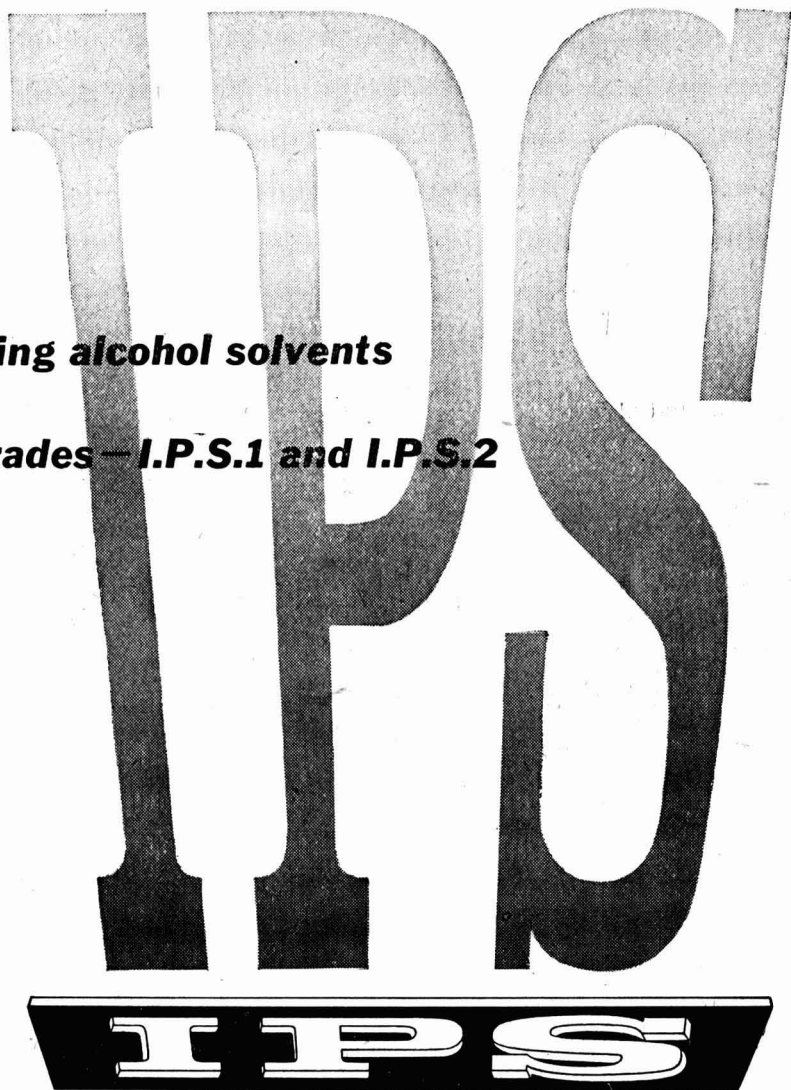

Low-boiling alcohol solvents

in two grades—*I.P.S.1* and *I.P.S.2*



Shell Chemical Company Limited

Norman House, 105-109 Strand, London, W.C.2. Telephone: Temple Bar 4455

Sales Offices :
LONDON : Walter House, Bedford Street, W.C.2. Tel: Temple Bar 4455.
MANCHESTER : 144-146 Deansgate. Tel: Deansgate 6451.
BIRMINGHAM : 14-20 Corporation St., 2. Tel: Midland 6954-8
GLASGOW : 124 St. Vincent Street, C.2. Tel: Glasgow Central 9561.
BELFAST : 35-37 Boyne Square. Tel: Belfast 20081.
DUBLIN : 53 Middle Abbey Street. Tel: Dublin 45775.

* Overseas enquiries should be directed to local Shell Companies.

INDUSTRIAL SAFETY • Fire and Accident Prevention and Protection

NEPR

LIQUID NEOPRENE PROTECTIVE COATINGS

Heavy duty coating applied at our works, for VALVES, TANKS, CHEMICALS & MARINE PLANT.

Maintenance grade supplied ready for use, for the protection of STEEL WORK from FUME & SPLASH.

ANTI-CORROSIVE

WEATHERPROOF

ANTI-ABRASIVE

HIGH-ADHESIO

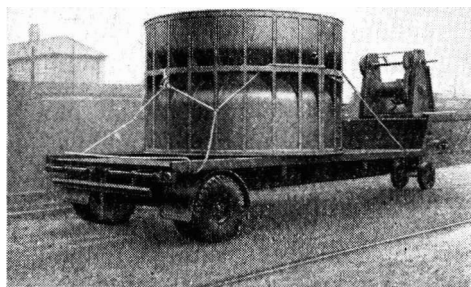
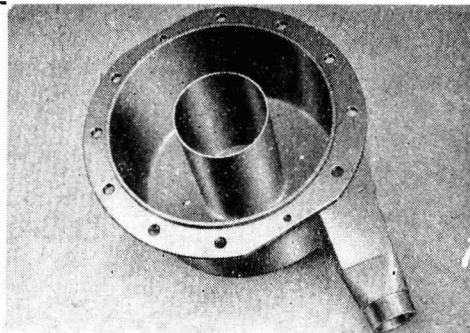

EAGLE WORKS . WEDNESBURY
TELEPHONE . WED 0284 5 LINES

We are the sole licensees in UK. for
Gates Engineering Co. USA' Gaco Processes

SAFETY FIRST

THE "OLDBURY" PATENT
CARBOY DISCHARGER
will empty and elevate up to 50 feet
the contents of any carboy, bottle or
vessel, and complies with all the con-
ditions of the Factory Act of 1937.

KESTNER'S

5, Grosvenor Gardens, Westminster, London, S.W.

Decolorising CARBON

ALL GRADES
FOR
ALL TRADES

HIGHEST EFFICIENCY
LOWEST PRICES

Granular Carbon for Solvent Recovery
Regeneration of Spent Carbon

Write for samples and quotations.

FARNELL CARBONS LIMITED
CONDUIT ROAD, PLUMSTEAD, LONDON, S.E.18

Telephone:
Woolwich 1/58 (2 lines)

Telegrams:
Scorar, Wol, London.

SAFETY IN THE CHEMICAL INDUSTRY

Articles on Non-sparking Tools, Safe Floors, Bursting Discs, Fire Precautions, Protective Clothing, etc., have and will be regularly appearing in THE CHEMICAL AGE.

Readers are invited to send the name and address of any executive interested in these important subjects. A specimen copy will be sent free on request. Applications should be made to:-

THE PUBLISHER,
THE CHEMICAL AGE,
154, Fleet Street, London, E.C.4

INDUSTRIAL SAFETY • Fire and Accident Prevention and Protection

The **Jefco**

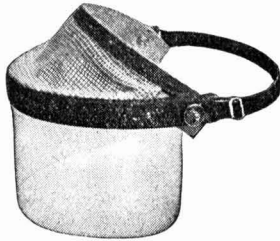

FACE SCREEN

Reg. Design 751914 Patent applied for

Perfect protection when grinding or machining. Comfortable to wear, stands clear of the face, adjustable to any angle, non-splinter front easily renewable.

J. & E. FERRIS LTD

33 Museum St., London, W.C.1

NON-SPARKING

SCRAPERS

← PUSH

14 ozs:



9 ozs:



ONE MONTH FREE TRIAL

SELF LOCKING HEAD
WET OR DRY

PATENT. PEN. 13993/55

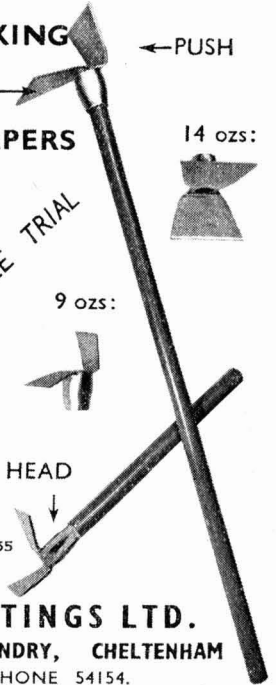

MEIGH CASTINGS LTD.

UCKINGTON FOUNDRY, CHELTENHAM

TELEPHONE 54154.

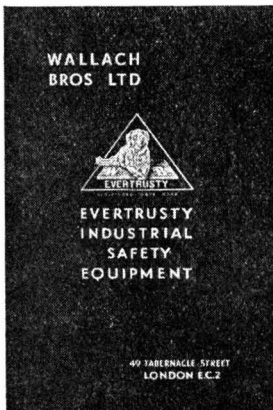

—FOR SAFETY

A NEW and revised edition of our famous "Blue Book of Safety Equipment"—loose leaf for your added convenience—illustrating and describing our complete range of Industrial Protection—will be sent on request.

Write for *your* copy to-day.

WALLACH BROS., LTD.

49, TABERNACLE STREET,
LONDON, E.C.2

Phone : CLERkenwell 1448/9

SPECIALISTS IN INDUSTRIAL SAFETY FOR 70 YEARS, AND MEMBERS OF THE ROYAL SOCIETY FOR THE PREVENTION OF ACCIDENTS



with

TELCON

BERYLLIUM COPPER

TOOLS

Beryllium Copper Safety Tools, by reason of their comparatively high thermal conductivity, have little tendency to spark and can be employed with confidence in dangerous atmospheres. The great strength and hardness of these tools gives them a performance and length of life assuring their superiority in this field, and their best recommendation is their widespread use by major industrial concerns handling inflammable materials.

Distributors for Great Britain

BERYLLIUM & COPPER ALLOYS LTD

47, VICTORIA STREET, LONDON, S.W.1 ABBey 6421/2

Manufactured by

TELEGRAPH CONSTRUCTION & MAINTENANCE

TELCON WORKS • MANOR ROYAL • CRAWLEY • SUSSEX

Volume LXXIV

Number 1921

Established 1919

The Chemical Age

The Weekly Journal of Chemical Engineering and Industrial Chemistry

BOUVERIE HOUSE · 154 FLEET STREET · LONDON EC4

Telephone : FLEET STREET 3212 (26 lines) Telegrams ALLANGAS · FLEET · LONDON

CONTENTS . 5 MAY 1956

Possible USSR Purchases	996
Mechanism of Some Reactions to Organo Metallic Compounds	997
Chemical Exports for March	1000
Symposium on Vegetable Tannins	1001
Board of Trade Order	1007
In the Editor's Post	1008
OCCA Annual Meeting (London Section)	1009
Safety Notebook	1010
The Chemist's Bookshelf	1011
Home News Items	1013
Overseas News Items	1014
Personal	1015
Mobile Elevator	1016
Law & Company News	1017
Market Reports	1018
Next Week's Events	1020

Editor : *E. Arnold Running*

Manager : *H. A. Willmott*

Director : *N. B. Livingstone Wallace*

MIDLANDS OFFICE :
Daimler House, Paradise
Street, Birmingham

Phone : Midland 0784/5

SCOTTISH OFFICE :
116, Hope Street,
Glasgow, C.2

Phone : Central 3954/5

LEEDS OFFICE :
Martins Bank Chambers
Park Row, Leeds, 1

Phone : Leeds 22601

SINGLE COPY 1/3 (BY POST 1/6)

ANNUAL SUBSCRIPTION 52/6

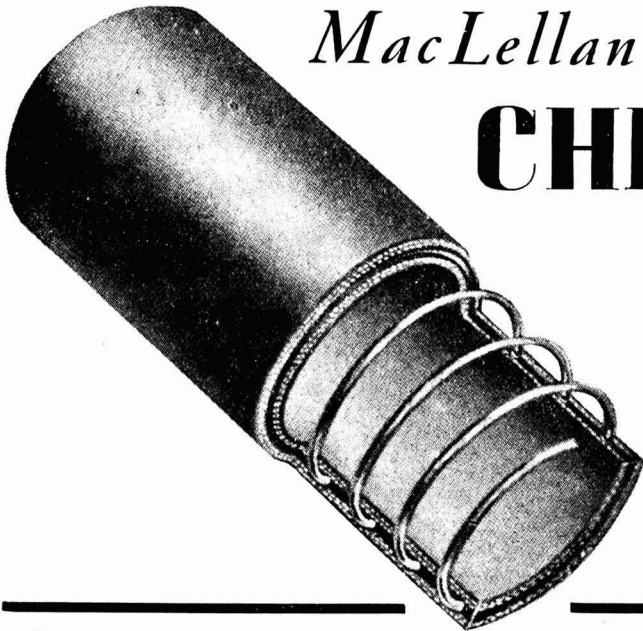

MacLellan Special CHEMICAL HOSE

A specially compounded cover and lining make MacLellan totally embedded suction hose *completely acid resisting.*

Used by leading chemical companies throughout the world. In maximum lengths of 60 feet.

Bore from 1 in. upwards. Illustrated is the smooth bore and smooth cover type. Smooth bore and corrugated cover also available.

GEORGE MACLELLAN & Co., LTD.

Phone : MARYHILL 2255/9

Grams : "CAOUTCHOUC" GLASGOW

MARYHILL GLASGOW N.W

LONDON WAREHOUSE
BURSTON ROAD, S.W.15

Acid handling

PORTABLE PUMPING UNITS

FOR REGULAR OR AUXILIARY WORK

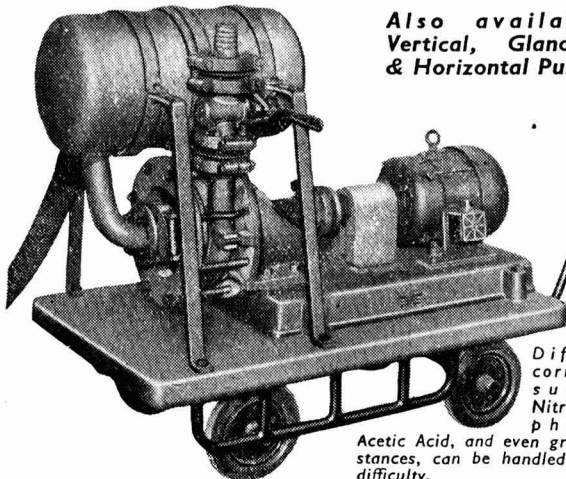
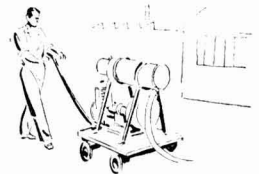

Also available
Vertical, Glandless
& Horizontal Pumps

Lennox Portable Pumping Units are invaluable in every Factory where Chemicals are employed. The Pump is easily wheeled to the required position and can be connected with flexible pipe in a few minutes. It will empty Store Tanks, Pickling Tanks, Sludge Sumps, Tank Wagons, etc., and deliver the contents wherever required.

Difficult
corrosives,
such as
Nitric, Sul-
phuric,

Acetic Acid, and even gritty substances, can be handled without difficulty.



LENNOX FOUNDRY CO. LTD.

Tantiron Foundry, Glenville Grove, London, S.E.8.

Chemists at Work

THE results of a comprehensive professional and economic survey of ACS members have just been published (*Chemical & Engineering News*, 1956, 34, 1731), the first large-scale effort of this kind since 1944. In between there have been limited surveys, such as annual surveys of starting salaries, or fragmentary 'small-sample' surveys, but no major survey seemed justifiable while inflationary tendencies influenced earnings so strongly. However, during 1952-54 the smaller survey efforts of the ACS indicated some stabilization of these inflationary forces, so a large-scale 1955 effort of inquiry and collation was begun. No one could describe the resultant information as anything less than impressive; the full details take up more than 40 pages of *C. & E. News*, with as many graphical presentations as any multi-phase process of chemical engineering.

It would have been pleasing to be able to use this new survey for making Anglo-US comparisons, but any such effort must be piecemeal and speculative. Equally broad and detailed information about chemists' economics on this side of the Atlantic does not exist, although the surveys conducted by the Royal Institute of Chemistry are fairly reliable measures of the Institute's own members' economics. But the ACS is obviously more all-embracing than the RIC. Whether a wider

British survey would produce information of greater value than the 'snapshot' picture of its own moment, it is difficult to assess. Inflationary tendencies are certainly still operative here—but are they actually in significant operation for chemists? It is the privilege of the professions in this country to endure maximum time-lags in compensation for £-value changes. However, it is not particularly fruitful to discuss a survey not in fact being contemplated here, except perhaps to make this point that the considerations which held off an ACS survey after 1944 probably apply far less forcibly here.

Information was provided for the survey by 70 per cent of the entire ACS membership—and to give a rather more solid idea of what this means, it comprised returns from 45,432 members living and working in the United States. This figure ignores additional returns from members abroad or with forces etc. There is no reason to look upon this sample as inadequate for general deductions. Even the geographical or regional influences that tend to bias all such surveys in America would seem to have had their complicating effects neutralized for the locational distribution of the replies was not different from the locational distribution of the questionnaire mailing-list. It is safe enough to say that

whatever is revealed through this 1955 survey faithfully represents the state of chemists in the US.

Some simple points about qualifications might be mentioned first. In chemistry, doctorates predominated as a class—42 per cent; in chemical engineering, this was not the case, bachelors' degrees easily leading the qualification class at 62 per cent. We can make a small Anglo-US point on this particular fact. One of the 'social' arguments about expanding technological education in the UK is that higher-degree recognition for technological and chemical engineering work would follow, thereby narrowing a difference between this kind of scientific work and that of the more traditional 'chemical' career. It is often felt that this problem of differential exists much less in America and is one reason why technological science there makes more impressive advances. These survey figures hardly support that view. Chemical engineering, if not industrial chemistry in the fullest sense, seems to proceed there without much seeking after higher degrees. Even in the miscellaneous section of 'other fields of science or engineering,' *i.e.*, where ACS members follow careers that are not directly 'chemical', higher degrees than the bachelor degree form the major class—doctorates, 42.6 per cent, masters, 24.9 per cent. It is suggested in the ACS survey that the low percentage for doctorates in chemical engineering represents the greater respect for experience in this work, the lesser importance paid to formal education. There were, incidentally, three times as many chemists as chemical engineers in the 70 per cent return.

The sex balance of the return revealed that chemistry is still mainly a masculine pursuit: 95 per cent male, 5 per cent female. This ratio of 19:1 may not, perhaps, be an entirely accurate reflection of chemical employment facts. There is some tendency for women chemists not to join professional groups, though how far this occurs in the US as well as here we do not know. Unless considerable allowance has to be made for this factor, we find it surprising that even by 1955 the female invasion of chemistry remains so small. But this may also reflect the

higher wastage factor, the frequent retirement for marriage.

That chemists often transfer to other types of work much less chemical in nature is well known. The survey shows that both from the chemistry and chemical engineering groups there is about the same extent of transfer—nearly 10 per cent. The figure probably includes real wastage through failure, through decision not to proceed with chemical careers, as well as chemical loss by promotion to managerial or administrative posts. But at a time when the Western world is greatly concerned with chemical manpower supply, this figure is very high.

As for the intensively human matter of remuneration, it would indeed be useful if transatlantic comparisons could be made. But is there any sound exchange-rate measure for the dollar and the pound as units of income? The value of an income is dependent upon a country's cost of living, upon so many internal factors that differ greatly in the UK and the US. When these complexities are faced, the exchange-rate for pound-dollar trading is far from applicable. But there is one comment in the ACS survey that may be worth much more than any attempts at comparison. Using data from former surveys as well (1941, 1943) this conclusion is reached: 'The increase in incomes of chemists and chemical engineers for the period covered have more than kept pace with the declining purchasing power of the dollar, and the relative gain was greatest for the most recent graduates'. Do we need figures from a large-scale survey here to know that this could not be said about British chemists' rewards?

Yet to ask that question is not to present a sectional grouse—it can be asked about every professional class in the country. High degrees of skill and knowledge here have not been insulated from inflation—chemical skill in America apparently has. Here fairly clearly is an incentive differential, and one not lightly dismissed by pleas that man does not live by bread alone. It is not just a matter of keeping up with the Joneses. It is more importantly a matter of freedom of mind, absence of anxieties about family costs—freedom from pressures that interfere with quality of work.

Notes & Comments

Pricewise or Unwise?

IT IS unfortunate that some politicians in this country attack business, and especially big business, by instinct. To them all operations of companies and directors are villainous machinations, opposed by nature to the public good. Mrs. Barbara Castle, speaking in the debate on the Restrictive Practices Bill, presented this extract from a letter written by a farmer: 'If we could persuade the ancillary industries to reduce their profit margins, farming costs would be slashed by 10 per cent or more immediately.' There seems little doubt that Mrs. Castle believed this statement—perhaps the instinct to think the worst of business motives discourages objective thought.

Villains of the Piece?

HOWEVER, if the statement were true, the matter would be one of high national importance. Few changes could help agriculture (and the country's costly support for farmers) more than a 10 per cent cut in costs. If the firms who make fertilizers, weedkillers, compound foods for animals etc. are maintaining higher prices than they should (or could), they are indeed villains of the piece, for they are exploiting both farmers and the State. Nor can it be denied that many of these firms pay good dividends, and often in these past few years improving dividends.

Margins of Profit

SO WHAT? Could they cut prices by 10 per cent? Without, that is to say, reducing standards of quality and service. We are indebted to *Agricultural Merchant*, the journal of the National Association of Corn and Agricultural Merchants, for the straightforward and devastating reply to this £70,000,000 question. A typical large firm engaged in supplying materials to farmers—perhaps fertilizers in the main, but feedingstuffs and seeds etc., too—is

Scottish Agricultural Industries. Last year their turnover was £23,000,000 and their net profit, just above £500,000—a net profit of just over 2 per cent on turnover. Where is the mystic margin out of which a 10 per cent cut in prices can be bestowed upon customers? Unfortunately many firms do not publish sales turnover figures so this argument cannot be widely exemplified. However, it is shown clearly in *Agricultural Merchant* that other firms work on net profit rates that run between 2 and 3.5 per cent of turnover.

Official Figures

INLAND Revenue figures can also be used. Thus, for the chemical industry, these figures show a gross profit margin of 10 per cent on turnover. Does this suggest that a 10 per cent price-cut on chemicals for farming is in fact possible? But the gross profit of 10 per cent must first face its deductions for taxation, its adjustments to allow for plant depreciation etc. Nor would the general index for profit rate in the chemical industry be applicable to the section making and supplying farm chemicals, for this section particularly works on a system of high tonnage and minimum prices.

Nonsensical Arguments

THESE facile arguments that costs can be slimmed by patriotic actions in industry's boardrooms are nonsensical. Airing them does no good to the country's sense of unity and can sometimes do much harm. For when customers think a 10 per cent cut on prices could be given by pressing a button, so must workers think that some of this wide margin of profit might as well come their way by a further wage-claim! Mrs. Castle should not play 'party politics' at the expense of national unity for at the moment the state of our economy calls for 100 per cent co-operation and a united effort as great as was needed during the recent war.

Possible USSR Purchases

Interested in Terylene & Polythene

FOLLOWING the conclusion of the discussions between the Prime Minister, Sir Anthony Eden, and Mr. Bulganin and Mr. Khrushchev of the USSR, the Board of Trade examined the list of goods which the Russians had suggested they would like to buy and classified it from the point of view of strategic controls. The BoT classified list reveals that the Soviet is interested in purchasing technological equipment for the production of both Terylene and low pressure polythene to the value of 50,000,000-75,000,000 roubles each and that this equipment is not affected by the strategic export controls.

Talks have been going on for some time between Soviet officials and representatives of Imperial Chemical Industries Ltd. regarding the purchase of 'know-how' for the manufacture of Terylene but it is not known which low-pressure polythene process the Russians are interested in.

With regard to the purchase of equipment for the Soviet chemical and rubber industries to the value of 100,000,000-200,000,000 roubles and an unstated amount of unspecified chemicals the Board of Trade announces that further information is needed before sales can be approved.

The BoT list also mentions that 35 compressor units for the chemical industry are

required by the Russians but some types of these plants are subject to embargo. The same applies to 100 vacuum pump units.

Among the equipment requested by the Russians which is subject to embargo is pump and compressor equipment (including compressors, capacity 300-2,000 hp; high and ultra-high pressure feeding pumps) to the value of 80,000,000 to 100,000,000 roubles.

du Pont Plan British Plant

ON FRIDAY 27 April E.I. du Pont de Nemours & Co., of Wilmington, Delaware, announced their intention to form a British subsidiary company, du Pont Co. (United Kingdom) Ltd. to provide British-made herbicides. The new company will produce the substituted ureas, Telvar herbicide for industrial use, and Karmex herbicide for agricultural purposes. The company will also explore the possibility of manufacturing other du Pont chemicals in the UK.

Telvar and Karmex herbicides are now imported and sold by Fisons Pest Control Ltd. who will continue to act as distributors of these products for du Pont (United Kingdom) Ltd. These substituted ureas are powerful and versatile biologically active chemicals, notable for their regulatory action on plant growth. The du Pont Co. has spent more than £1,000,000 in the study and development of such herbicidal compounds.

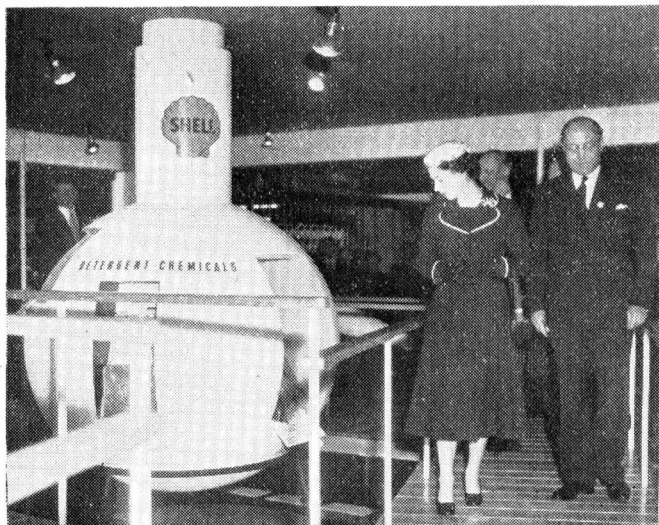

Her Majesty the Queen with Mr. L. H. Williams, managing director of Shell Chemical Co. Ltd., on the company's stand in the chemical section at Olympia of the British Industries Fair

Mechanism of Some Reactions of Organo-Metallic Compounds

by SIR ROBERT ROBINSON, O.M., D.Sc., F.R.I.C., F.R.S.

Sir Robert Robinson, director, Shell Chemical Co. Ltd., was Waynflete Professor of Chemistry at Oxford University from 1936 to 1955. Born in 1886, he was educated at Fulneck School, near Leeds, and at the University of Manchester. From 1912 to 1915 he was professor of organic chemistry at the University of Sydney. In 1915 he was appointed Heath Harrison Professor of Organic Chemistry at Liverpool, and in 1920 he became director of research, British Dyestuffs Corporation Ltd. From 1922 to 1928 he was professor of organic chemistry at Manchester and was professor of organic chemistry at University College, London, from 1928 to 1930.

Sir Robert Robinson was awarded the Nobel Prize for Chemistry in 1947. He was president of the Chemical Society from 1939 to 1941, president of Royal Society from 1945 to 1950, and president of the British Association for the Advancement of Science in 1955. He was the Royal Society's Bakerian Lecturer in 1929, Longstaff Medallist of the Chemical Society, Davy Medallist of the Royal Society in 1930, Royal Medallist in 1932, Copley Medallist in 1942, and Priestley Medallist of the American Chemical Society in 1953.

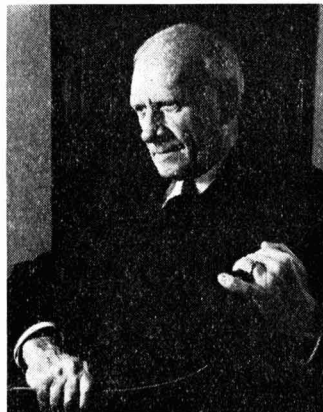

IN the course of a lecture delivered at the Sir John Cass College on 9 February 1956, I considered the mechanism of the Ziegler reaction and analogous processes and developed the argument along the following lines:

The organic residues of the organo-metallic compounds have usually been regarded as anionoid (nucleophilic), and a typical reaction has been represented schematically in the following manner.

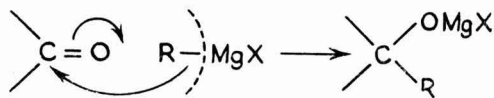

Though this is doubtless correct overall, the first stage of the process is almost certainly co-ordination of the magnesium atom with the oxygen of the carbonyl group so as to produce an intermediate complex.

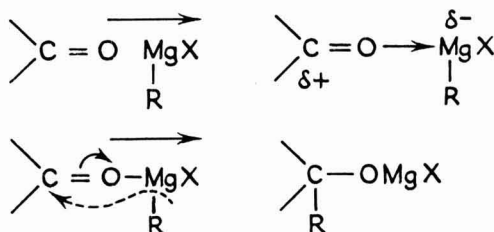

A migration of the group R, with its electrons, to carbon will then occur as illustrated. While these processes can be represented in this way as involving virtual ions and therefore a polar reaction, it is also possible to contemplate a related homopolar process in which, for example, the group R migrates as a neutral radical. This consideration applies in a much wider field and is only mentioned as a *punctilio* because organo-metallic compounds do, in fact, behave in many respects as if they were sources of radicals. The polar mechanism is used in the sequel with the understanding that there is always a homopolar equivalent.

For a long period it was considered that the essentially anionoid olefines would not react with organo-metallic compounds, which are also recognized as anionoid in character. Nevertheless, it must be recognized that the circumstances will be dependent on the degree of activation of the double bond. This should always provide a position with available electrons on carbon and another in which there is electron defect. An olefine will not usually approach the degree of polarization of a ketone; nevertheless, the same dipole character must be present to some extent. It is important to take cognisance of the idea that the degree of

activation or polarization of an olefine may be greatly varied according to the circumstances and hence we might expect that an activated or polarized ethylene would in fact react with organo-metallic compounds, at least up to the initial stage of formation of a complex by attack of the metal atom as postulated above.

It is necessary also to recall the highly significant experiments of Norrish (*J. Chem. Soc.*, 1923, 123, 3006) who showed that ethylene does not react with chlorine in a flask coated with paraffin wax, although the reaction proceeds in a glass flask and very rapidly when the gases are in contact with salts, such as calcium chloride. This showed plainly enough an activation of the ethylene molecule on the polar surfaces. By analogy with the above conception of organo-metallic reactions in general, the fundamental Ziegler reaction in a simple example can be expressed as follows:

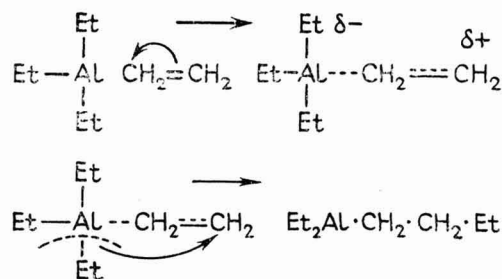

The first stage of this process may, in accordance with the above suggestions, be regarded as an attack of the aluminium atom by an activated, possibly a polarized, ethylene molecule. The resulting complex will then undergo transformation by migration of a group and thus a new aluminium tri-alkyl is obtained.

A further most important element of the Ziegler complex of reactions is the reversible decomposition of suitably constituted aluminium alkyls into α -olefines and a di-alkyl aluminium hydride, for example:

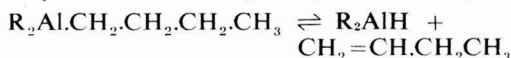

The process, left to right, is favoured by higher temperatures and is catalysed by nickel.

Conditions can, therefore, be chosen in which this dimerization can be made the main event and, for example, propylene can be dimerized by operating at 200 atmospheres pressure and 150°-200°C. If an

excess of ethylene or other olefine is employed under suitable conditions a much longer hydrocarbon chain can be set up so that waxes may be produced. This depends doubtless on the attack of the intermediate complex symbolized above by further activated olefine molecules which, however, are either in low concentration or must be regarded as possessing an inferior degree of activation. This limited polymerization process may be expressed as follows:

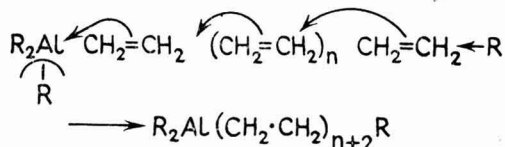

The products are still aluminium tri-alkyls and will undergo the decomposition reaction to olefine and di-alkylaluminium hydride as already mentioned. If this decomposition is brought about by the catalytic effect of the double bond of the α -olefine into the hydrocarbon chain and Ziegler and his collaborators found that this undesirable effect could be controlled by the introduction of small amounts of acetylene derivatives, for example, phenylacetylene, into the system. This theory gives the correct results in respect to orientation of the dimerization and polarization. The sites of electron availability are just those which are already recognized and it is from these points that the aluminium atom must be attacked. The following illustrate the resulting orientation in the syntheses.

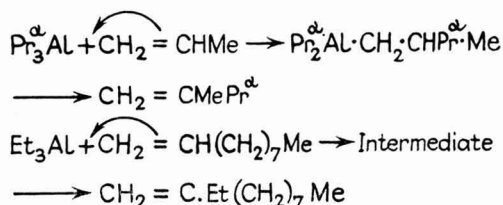

It does not seem necessary to postulate any different mechanism, even for the high polymerides, which result from the presence of a much higher concentration of still more activated olefine molecules. This is presumably the function of the second half of the Ziegler catalyst system. It is now well known that on the addition of a solution of titanium tetrachloride to one of a suitable aluminium alkyl, a precipitate is

thrown down and that in some way the polyolefine is produced by the joint action of the aluminium and titanium catalysts. The present suggestion is that the macropolymerization is still an organo-metallic reaction as already explained and the new circumstance is simply that the solid titanium salt precipitate for some reason presents a surface on which the ethylene molecules are exceptionally well activated and are thus in a condition in which they can, as it were, be 'zipped' up by the organo-metallic compound. Such a theory accommodates the necessity for the organo-metallic component whether it be a compound of magnesium, aluminium or zinc or even simply an alkali metal which, although not an organo-metallic reagent, may be regarded as of similar character.

On the other hand, the process falls into the category of heterogeneous catalysis in which the olefine is activated on the surface. The difference of this from the polymerization to a wax is then merely one of greater activation, greater concentration of the active molecules and hence a very much more facile lengthening of the hydrocarbon chain, but it is not fundamentally different in character. This duplex mechanism is on the

side of the heterogeneous catalysis strongly supported by observations recently made that conditions can be selected so as to favour the building up of crystalline, sterically homogeneous, macro-molecules. The templates for the activated olefines in this case are the crystalline lattices of the solid component.

Incidentally the distinction between high pressure and low pressure polymerization conditions tends to become exiguous since the virtual pressures of gases adsorbed on solid surfaces are very high.

Finally there would not be much to be gained by a discussion of the intramolecular or intermolecular nature of the transference of the R group from the metal to the end of the olefine chain of n molecules. The two processes are electrochemically indistinguishable and, when $n=1$ or 2, the reaction is probably intramolecular, that is, R is derived from that molecule of AIR₃ which is attacked by C₂H₄. When n is very large, the chain-ending R group most probably comes from an external source, most likely the end of another macro-molecule in course of formation. When n has an intermediate value, the intra- and intermolecular processes may be mixed in various proportions.

Air Pollution Meeting

AIR pollution control will be discussed at the Air Pollution Control Association's annual meeting in Buffalo, NY, from 20 to 24 May at the Hotel Statler. It will be APCA's 49th annual international meeting. Mr. H. Kenneth Kugel, Washington, DC, air pollution control official and a recognized authority in the air pollution control field, will preside as president. The meeting will bring together about 800 industrialists, educators, administrators, scientists, and municipal authorities.

Exhibits featured at the meeting will be the latest equipment for reducing air pollution, and a working model wind tunnel placed adjacent to a scale model of the Huntley station of Niagara Mohawk Power Corp., a project jointly sponsored by Niagara Mohawk and New York University to study the effects of smoke from the power station under varying conditions. There will also be guided tours through the Cellophane plant of E. I. du Pont de Nemours

& Co., the Bethlehem Steel Co., the Huntley power station, and the Niagara Falls plants of Hooker Electrochemical Co., and Electro Metallurgical Co., a division of Union Carbide & Carbon Corp.

Instrumental Analysis

TO SURVEY for practising analysts the principles of instrumental chemical analysis, the Massachusetts Institute of Technology will again present two one-week special summer programmes on optical methods and electrical methods of instrumental chemical analysis during the 1956 Summer Session.

The first, 'Optical Methods in Instrumental Chemical Analysis', will be given from 20 to 24 August; the second, 'Electrical Methods in Instrumental Chemical Analysis,' will be held from 27 to 31 August. The programmes have been designed for those with a Bachelor's Degree or its equivalent in experience.

Chemical Exports for March

India Still the Principal Buyer

FOR the first three months of this year British chemical exports have remained constant. India, despite spending £343,134 less in March than in February, is still the principal buyer, followed by Australia and South Africa. Total exports of elements and compounds dropped slightly from £5,190,396 in February to £5,127,056 in March. Exports of medicinal and pharmaceutical products increased from £2,745,397 in February to £3,199,391. Among the countries which increased their imports of British chemicals in March were the Netherlands, Canada, Sweden, France, Egypt, and Turkey.

EXPORTS: PRINCIPAL COMMODITIES

	Mar. 1956	Feb. 1956	Mar. 1955
Acids, inorganic (cwt.)	15,781	15,214	16,492
Copper sulphate (tons)	3,423	7,464	4,905
Sodium hydroxide (cwt.)	630,148	570,601	304,042
Aluminium oxide (tons)	1,149	1,523	1,768
Aluminium sulphate (tons)	3,262	3,554	2,471
Ammonia (cwt.)	9,201	8,515	10,061
Bismuth compounds (lb.)	19,259	24,078	39,745
Bleaching powder (cwt.)	34,642	30,431	34,376
Hydrosulphite (cwt.)	4,571	3,124	10,108
Calcium compounds inorganic (cwt.)	23,527	24,142	35,502
Lead compounds inorganic (cwt.)	3,040	3,022	5,323
Magnesium compounds (tons)	1,142	1,099	880
Nickel salts (cwt.)	6,478	5,042	8,516
Potassium compounds (cwt.)	3,398	3,683	5,627
Acids, organic & derivatives (value in £s)	87,982	118,162	56,044
Ethyl, methyl, etc., alcohols (value in £s)	93,492	108,896	165,441
Acetone (cwt.)	8,434	12,392	7,941
Citric acid (cwt.)	3,073	2,670	3,337
Sulphonamides unprepared (lb.)	338,425	67,094	193,948
Dyestuffs intermediates (lb.)	7,769	7,584	4,885
Total for elements & compounds in £s	5,127,056	5,190,396	4,762,466
Coal tar (tons)	4,963	15,157	8,952
Cresylic acid (gal.)	267,223	205,884	301,611
Cresote oil (gal.)	1,069,316	1,031,364	2,634,913
Total for tar products in £s	309,125	329,119	401,325
Total for synthetic dyestuffs (cwt.)	712,373	20,094	855,361
Total for paints, pigments & tannins in £s	1,944,497	1,888,779	1,752,875

Total for medicinal & pharmaceutical products in £s	3,199,391	2,745,397	3,043,051
Total for essential oils, perfumes, etc. in £s	2,367,004	2,095,527	2,028,370
Ammonium nitrate (tons)	709	617	562
Ammonium sulphate (tons)	1,648	35,891	9,406
Total for all fertilizers in £s	99,264	749,677	258,899
Total for plastics materials (cwt.)	157,442	143,330	152,402
Disinfectants etc. (cwt.)	12,859	8,967	10,437
Insecticides, fungicides & rodenticides (cwt.)	36,321	39,659	36,941
Weedkillers (cwt.)	7,142	3,393	12,207
Lead tetra-ethyl (gal.)	327,315	413,581	596,626

VALUE OF EXPORTS IN £S: PRINCIPAL BUYERS OF CHEMICALS

	Mar. 1956	Feb. 1956	Mar. 1955
India	1,719,046	2,062,180	1,861,298
Australia	1,314,104	1,462,651	1,714,666
South Africa	1,051,078	1,059,596	1,051,078
Netherlands	814,483	645,051	616,971
United States	778,818	812,152	698,197
Italy	706,981	756,416	412,637
Canada	629,761	552,186	441,187
Sweden	604,580	341,759	527,910
France	597,939	456,268	763,164
West Germany	546,609	442,247	527,695
Eire	516,076	605,975	589,833
Nigeria	481,057	438,906	395,894
Egypt	474,831	316,013	343,673
Gold Coast	469,211	381,636	323,567
New Zealand	466,875	612,094	660,561
Belgium	449,948	544,390	459,249
Denmark	406,521	403,362	320,823
Switzerland	366,031	226,103	268,005
Singapore	323,914	411,127	368,753
Norway	315,711	279,833	288,364
Netherlands Antilles	306,648	220,428	431,305
Jamaica	301,716	205,453	160,080
Indonesia	298,353	191,458	307,757
Argentina	295,814	205,966	597,070
Malaya	294,078	288,463	294,748
Finland	277,306	230,631	264,466
Hong Kong	275,826	224,588	336,758
Iraq	225,517	276,543	131,708
Pakistan	224,595	108,046	368,042
Turkey	217,648	167,659	90,935
Burma	213,220	212,656	244,935

Total value of chemical exports **20,367,578** **20,185,830** **20,774,993**

Pascall's Move

On Monday the Pascall Engineering Co. Ltd., manufacturers of chemical plant, of Marylebone, London, are moving to their new factory at Gatwick Road, Crawley, Sussex. Customers of the firm are invited to visit the factory.

Symposium on Vegetable Tannins

by Dr. H. E. NURSTEN, Department of Leather Industries, Leeds University

THIS Symposium, arranged by the Society of Leather Trades' Chemists, was held in the Chemistry School, Pembroke Street, Cambridge, on 12 and 13 April 1956. The president of the Society, Dr. R. G. Mitton (BLMRA), welcomed all those attending and introduced the chairman for the first day, Professor R. D. Haworth, F.R.S. (Sheffield University). There was an audience of about a hundred, most remarkable for the wide range of interests represented.

The morning session included four papers, the first of which, on 'The Scope of Vegetable Tannin Chemistry', was read by Dr. T. White (Forestral Central Laboratories, Harpenden). After describing the historical development of the term 'tannin', Dr. White showed that to exhibit a tanning effect a substance must possess a molecule large enough to crosslink adjacent collagen chains and a number of phenolic groups big enough to achieve combination at several points, yet the molecule must not be so large as to prevent penetration to the combining sites. These facts rule out compounds such as simple phenols, catechins (I), leucoanthocyanins (e.g. II), and coumaric acids.

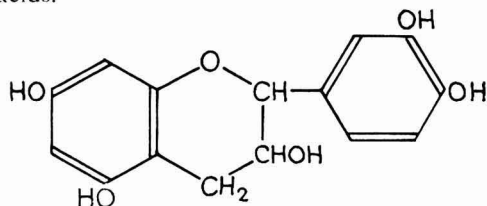

(I) Catechins

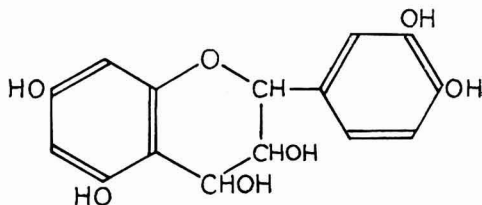

(II) Leucocyanin

The value of these substances to tannin chemistry is that their conjoint occurrence with tannins may indicate the type of aromatic nuclei that a particular plant employs.

The famous work of Emil Fischer and his colleagues on Turkish and Chinese gallotannin left the former formulated as a pentagalloylglucose and the latter as a penta-*m*-digalloylglucose. From paper chromatographic studies pentagalloylglucose is now shown to be of little, if any, significance in Turkish gallotannin. The Chinese, however, contains about two per cent of it together with about 20 per cent gallic acid, some seven per cent *m*-digallic acid, and some 70 per cent 'classic gallotannin'. The latter is probably a trisaccharide, nine of the 11 hydroxyl groups of which are esterified with six galloyl, one digalloyl, and two trigalloyl residues.

Dr. White subdivided condensed tannins into three groups: (a) those (Burma cutch, gambier, tea tannin) which are derived from catechins (I), (b) those (mallet, myrtan, and other eucalypts, mangroves, spruce, canaigre) which give a strongly positive

Seen here talking together at the time of the symposium are Dr. R. G. Mitton (centre) president of the Society of Leather Trades' Chemists, Professor O. T. Schmidt (left) and Dr. W. Mayer



test for leucoanthocyanins (e.g. II), and (c) those, the most important (quebracho, mimosa and other wattles, urunday, guayacan), which lack any significant content of catechins or leucoanthocyanins.

Modifying Effect

After stressing the dearth of physico-chemical data, Dr. White turned to consider the functions of the tannins in plants and pointed out that there is now a reasonable amount of information indicating that tannins do modify the effects of bacteria, fungi, and viruses on plants and that this may well be one of the main reasons why plants produce these substances.

In the discussion of the paper, Dr. E. C. Bate-Smith (Low Temperature Research Station, Cambridge) emphasized how well established the term 'tannin' was among botanists and that really they had as much right to their definition of it as the leather chemist to his. Mr. D. M. G. Armstrong (Royal Veterinary College, London) recalled that tannic acid had long been employed in the treatment of burns, which were healed, but some patients died because of attack on their liver. Use of tannic acid has therefore been abandoned except for minor burns. When injected into mice, condensed tannins are not dangerous, but the hydrolysable are.

Alkaline Fusions

'The Quantitative Determination of Specific Nuclei and Components of Vegetable Tannin Extracts' by Mr. H. G. C. King and Dr. T. White (Forestral Central Laboratories, Harpenden) was presented by the former. Much of our knowledge of the structure of the condensed tannins depends on the results of alkaline fusions. This is an unsatisfactory procedure and the authors had set out to determine quantitatively the various phenolic nuclei present in tannins.

The differences in the ultra-violet absorption spectra between neutral and alkaline solutions of mimosa extract permitted only qualitative conclusions, namely, that no free phloroglucinol groups are present and only few pyrogallol ones. By measurement of the reflectance of spots obtained by paper chromatography, however, the following results were obtained. Quebracho extract contains one per cent gallic acid. Mimosa extract contains 2.5 per cent glucose, one per cent arabinose, and 0.02 per cent catechins (I). The extract of fibrous mangrove

(*Bruguiera gymnorhiza*) contains 2.6 per cent glucose and yields, on treatment with boiling dilute hydrochloric acid, about 12 per cent cyanidin (III), two per cent delphinidin, one per cent pelargonidin, and one per cent of an unknown anthocyanidin. (The water-soluble colouring matters of plants and flowers, the anthocyanins, are converted by hydrolysis into sugars and anthocyanidins (e.g. III), which are also coloured. In the present case it is the leucoanthocyanins which are being transformed into anthocyanidins and for this they require more stringent conditions than the anthocyanins themselves.)

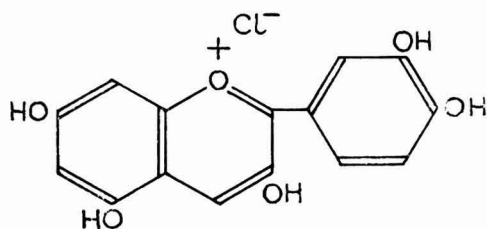

(III) Cyanidin Chloride

Reflectance spectra were also used to show that when tetramethylcatechin is oxidized with bromine in dioxan, cyanidin is formed in 43 per cent yield, together with other anthocyanidins, and that extracts from Chinese galls (tannic acid) contain 21 per cent free gallic acid and seven per cent free *m*-digallic acid.

Basing themselves on previous work, King and White developed a colorimetric method for measuring the concentration of the vicinal di- and tri-hydroxyl groupings present and of distinguishing between the contributions from each. The method depends on the colour produced by interaction with ferrous tartrate in presence of different buffers. The results can be tabulated, the first being particularly remarkable:

Material	Per Cent Pyrogallol nuclei	Per Cent Catechol nuclei
Quebracho extract	24.6	8.8
Mimosa extract	27.8	4.0
Chinese gallotannin	56.2	0.0

By heating resorcinol with syrupy phosphoric acid to about 200°C, a fluorescent compound is produced. An adapted form of this reaction shows the presence of resorcinol groupings which have at least one free position *para* to a hydroxyl group. Extracts gave the following reactions:

Strong

Quebracho, sulphited or not

Mimosa, sulphited or not
Urunday, sulphited or notGuayacan, sulphited or not
Tizerah
Green wattle
Silver wattle**Weak***E. sideroxylon**E. drepanophylla**E. paniculata*

Mangrove, fibrous or not

Canarie, Eastern or Western

Spruce

Myrtan (*E. redunca*)**Medium***Eucalyptus rostrata*,
kino
Mallet (*E. occidentalis*)
Oxidized mimosa
(O₂/alkali)
Gambier**None**

Chinese gallotannin

Chestnut

Oakwood

Valonia

Myrobalans

Divi-divi

Algarrobo

Lentisco

Tara

Burma cutch

Ligninsulphuric acid

Catechin

During the discussion on this paper, Dr. E. A. H. Roberts (Indian Tea Association Chemical Laboratory, London) suggested a manometric method based on oxidation with a ceric salt. Pyrogallol components would give off carbon dioxide after the *o*-quinone had been formed, whereas catechol nuclei would not go beyond the quinone stage.

Professor D. Burton, in presenting a joint paper with Dr. H. E. Nursten (Leeds University), entitled 'The Gallotannins and Ellagitannins', drew attention to the remarkable acidity of galloylated sugars and the consequent difficulties in deciding on an endpoint for the titration of the total acidity of tan liquors. He gave a mathematical justification, due to the late Professor W. R. Atkin, of the choice of pH 5.8 for this purpose.

After describing the dialysis method for assessing separately the non-tanning acids and their salts and the tanning acids and their salts, results for several tanning materials were quoted. Practically all the acidity of Sicilian sumach is due to non-tanning acids, which explains its mellowness. Cyprus sumach or lentiso, a common adulterant for sumach, contains considerably more tanning and non-tanning acids, while dhawa or 'country sumach', which is used in India as a substitute for sumach, contains much more tanning acids still.

Professor Burton went on to demonstrate how results obtained by his method can point the way to organic chemical research. While the excellent work of Professor Schmidt and his colleagues in Germany has characterized structurally a considerable proportion of the tanning acids and salts present in myrobalans, much scope remains

in the case of valonia and algarobilla. Using the method, Mr. J. B. Rao confirmed the presence of a carboxyl group in the tannin of chestnut and Mr. D. K. Ghosh found a carboxyl group in the tannin of tara, indicating that it is an ellagitannin and much more astringent than Sicilian sumach or dhawa. The data obtained was used to calculate average equivalent weights of tannins and these are of a similar order of magnitude as the molecular weights recorded in the literature.

Ghosh's attempts to separate physically the tanning acids from their salts by two methods were described, each being successful in some measure.

Finally, Professor Burton discussed the physiological origin of the hydrolysable tannins and focused attention onto the work of Dr. B. D. Davis and his associates on bacteria, which had demonstrated that the aromatic ring is synthesised by them from glucose via 5-dehydroquinic, 5-dehydroshikimic, and shikimic acids, and other compounds. The same pathway is most probably also used by plants, in which case the tannins must be derived from it. This is made very likely by the isolation of shikimic acid (IV) from sumach by Dr. G. N. Catravas in

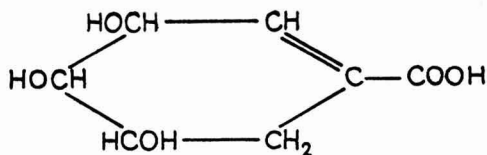
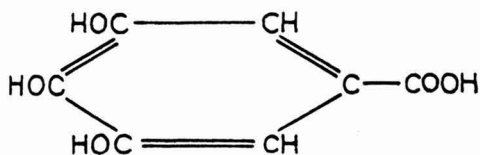
(iv) *Shikimic Acid**Gallic Acid*

Leeds in 1947. The occurrence in other tanning materials of shikimic acid either in the free state or combined was forecast and this prediction was fulfilled by the quite independent work by Dr. Hathway reported later in the Symposium.

In the discussion, Mr. King stated that

tara and Chinese gallotannin gave very similar chromatograms and Dr. White also was critical of classifying tara as an ellagitannin merely because of its carboxyl group. However, tara and gallotannin differ in optical rotary power and further work is called for.

The final paper of the morning was another fascinating instalment 'On the Constitution of Chebulinic Acid' by Professor O. T. Schmidt (Heidelberg University). On hydrolysis with water at 60°C, the bond (a) of this myrobalanitanin (V) is opened and a dibasic acid, designated neochebulinic acid,

noon session, one on 'The Polyphenols and Polyphenolase of Tobacco', was read by Dr. W. W. Reid (Carreras Ltd.). He described how he had fractionated extracts from tobacco leaves and the complicated two-dimensional paper chromatograms they yield. Tobacco when flue cured is a golden colour, whereas when air cured it is dark brown. An enzyme, polyphenolase, brings about the oxidative change and this enzyme is inactivated by the heat of flue curing. Under the action of the enzyme, chlorogenic and caffeic acids are oxidized and the reaction can involve other substances present. As it

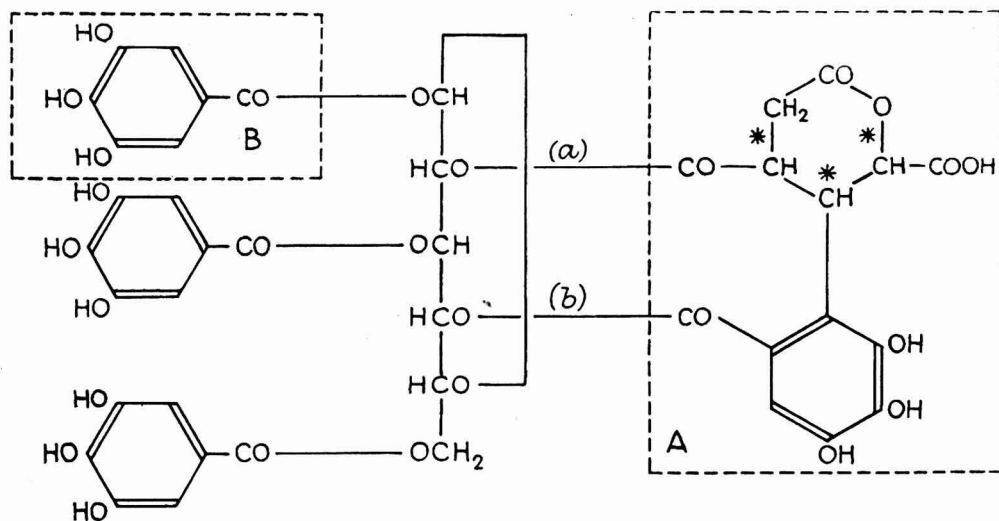

(V) Chebulinic Acid

is formed. It can be obtained crystalline and its production is one possible explanation of increased acidity produced on keeping myrobalans liquors. The next reaction in water at 60°C is the complete splitting off of chebulic acid (A in formula V) by rupture of bond (b), a further increase in acidity being obtained. The residual 1:3:6-trigalloylglucose, prepared also synthetically, is amorphous, and it was proved that the 1-galloyl group (B in formula V) is in the β -configuration as shown.

Chebulic acid contains three asymmetric carbon atoms (starred in V) and Professor Schmidt presented evidence, the result of much work, that the benzene ring is *trans* on the one side to the cyclic oxygen atom, on the other to the carbonyl group.

The first of the three papers of the after-

has been suggested that the content of chlorogenic acid is directly related to smoking quality, it is important that only traces have been found in air cured tobacco.

Dr. Roberts, whose paper was on 'Paper Chromatography as an aid to the Elucidation of the Structure of Polyphenols occurring in Tea', demonstrated that, when using two per cent acetic acid as the solvent, the introduction of an extra phenolic group into a molecule decreases its R_F value, that is, the substance moves more slowly on the chromatogram. A similar effect is brought about by increasing the planarity of a molecule. By means of examples, it was shown how these principles can be used to obtain valuable ideas about the structure of unknown components of extracts.

'Some Approaches to Aromatic Bio-

synthesis leading to Polyphenols and Tannins' by Dr. D. E. Hathway (BLMRA) was the last paper of the day. He described modern methods developed for the reliable identification of ellagic acid. They involve the preparation of the tetra(methoxycarbonyl) derivative and paper chromatography and by their use the presence of this acid in several dicotyledonous plants has been confirmed. Like Burton and Nursten, Dr. Hathway was interested in the non-aromatic precursors of the tannins and he therefore undertook an extensive and laborious examination of various myrobalans.

Among polyphenols he found chebulinic (V), chebulagic, chebulic, ellagic, and gallic acids, also corilagin, 3:6-digalloylglucose, and β -D-glucogallin, and a small amount of protocatechuic acid. In the amino-acid fraction, tyrosine, phenylalanine, and tryptophan were identified and another fraction yielded shikimic (IV) and quinic acids, together with smaller quantities of phosphoric, dihydroshikimic, and succinic acids, and possibly 5-dehydroshikimic acid. Dr. Hathway suggested that shikimic acid and related cycloaliphatic acids are precursors of the tannins and other aromatic compounds of plants.

Discussion

In the ensuing discussion, it was stated that, whereas only quinic acid can be isolated from young apples, shikimic acid can be obtained from old ones. This does fit in with the suggestion that shikimic acid is an intermediate readily metabolized and so evident only when the metabolic processes have slowed up.

The second day of the Symposium was devoted to five papers on catechins, leucoanthocyanins and related flavan derivatives. The chairman for the session was Dr. F. E. King, F.R.S. (British Celanese Ltd. lately of Nottingham University).

The opening paper by Drs. T. Swain and E. C. Bate-Smith (Low Temperature Research Station, Cambridge), entitled 'Leucoanthocyanins', was delivered by the former and consisted of a comprehensive review of their chemistry. Leucoanthocyanins are colourless or nearly colourless phenolic substances which yield anthocyanidins (e.g. III) on treatment with hot or concentrated acids. Some of them at least are flavan-3:4-diols (e.g. II) and thus have a lower state of oxidation than the anthocyanidins, namely that of dihydroanthocyani-

dins. A survey of 792 species of plants showed that leucoanthocyanins occur in 38 per cent of them, though woody families contained them more frequently (61 per cent) than herbaceous (15 per cent). The leucoanthocyanins give all the reactions of tannins and because of their widespread occurrence, particularly in woody plants, are of obvious importance to those interested in tanning. Dr. Swain pointed out that the main tannin reserves in the world are locked up in plants, such as the mangroves and *Pinus radiata*, mainly in the form of leucoanthocyanins.

In the discussion which arose, Dr. White stressed the fact that tanning materials based on leucoanthocyanins produce very poor leather and mentioned that there is not much fear of the immediate exhaustion of present-day tanning materials as, for example, the reserves of quebracho are estimated to be sufficient for another 400 years. Mr. A. H. Williams (Agricultural Research Council Unit of Plant Nutrition, Long Ashton, Bristol) stated that of the four leucoanthocyanins in cider apples three were mobile on chromatography and only one, on treatment with acid, gave a product containing catechin (I).

Dr. W. E. Hillis (CSIRO, Australia) then read a paper on 'Leucoanthocyanins as the Possible Precursors of Tannins'. By means of isopropanolic hydrochloric acid in sealed tubes, leucoanthocyanins were converted into anthocyanidins, the concentration of which was determined spectrophotometrically. In this way the following amounts of leucoanthocyanins were found in the soluble solids of tanning materials:

	Per Cent
Mangrove, <i>Rhizophora mucronata</i> , bark ..	45.0
<i>Pinus radiata</i> , bark	40.0
<i>Eucalyptus sideroxylon</i> , bark	28.0
Mallet bark	19.0
Myrtan bark	6.5
Wattle extract	5.5
Myrobalans extract	0.0

The wood of *P. radiata* is the basis of a large and growing pulp industry in Australia and New Zealand and the utilization of the bark, which contains 15-20 per cent tan, is an attractive proposition. Unfortunately the quality of the tannins is poor.

From an examination of *E. marginata* (jarrah), Dr. Hillis concluded that the leucoanthocyanins are formed in the leaves and move with the carbohydrates and other materials down the phloem, across the cambium, into the sapwood and heartwood.

During the later stages the leucoanthocyanins become transformed into 'tannins'.

The contribution by Dr. W. Mayer (Heidelberg University) was entitled 'Catechins from the Bark of Oak and Sweet Chestnut'. (+)Catechin and (+)gallocatechin, which contains an extra hydroxyl group, were isolated in the crystalline state from both sources. The former was identified readily with an authentic sample from gambier, but the latter proved less straight forward. Oshima had isolated it from the Australian pine, *Casuarina equisetifolia*, in 1939 and designated it casuarin, but Mayer's compound differed from it in some respects. Dr. Mayer therefore confirmed its structure thoroughly by chemical means. Apart from catechins the barks contain hydrolysable tannins, which exhibit the reaction for combined ellagic acid and yield on hydrolysis

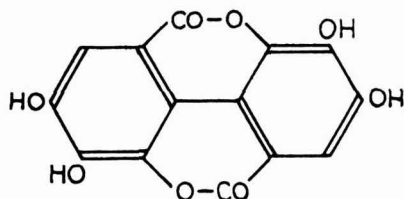

(VI) *Ellagic Acid*

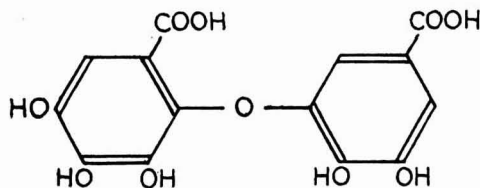

(VII) *Dehydrodigallic Acid*

glucose, gallic, ellagic (VI), and dehydrodigallic (VII) acids, together with other polyphenols. The amounts of (+)catechin and dehydrodigallic acid isolated were about one and 10 per cent of the total amount of tannin present, respectively.

During the discussion, Dr. Hathway stated that he had been unable to find any catechins in the wood of chestnut and Dr. Mayer said his results were the same.

A paper, 'Dihydroflavonols (4-Oxycatechins); Their Occurrence and Properties' by Dr. J. E. Gowan, Mrs. E. M. Philbin, and Professor T. S. Wheeler (University College, Dublin) was read by the last. It was the first

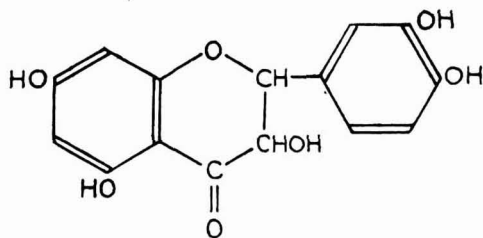

summary of the natural sources, the syntheses, and the reactions of these compounds (e.g. VIII). They are closely related to the substances discussed so far and are particularly remarkable for the changes they undergo when exposed to alkali.

During the discussion which followed, the occurrence of dihydroflavonols in several further species was mentioned; in particular, Dr. White stated that he had found three in quebracho.

The final paper of the Symposium, one on 'The Stereochemistry of the Chromans and Related Compounds', was delivered by Dr. W. B. Whalley (Liverpool University), who discussed the spatial relationships between the atoms in compounds such as the catechins and the leucoanthocyanins.

In retrospect, tribute must first of all be paid to the Society of Leather Trades' Chemists, and in particular to the officers responsible, for the excellent organization of the Symposium. Momentum was never lost, and, though the pace was gruelling, the result was inspiring and surprisingly enjoyable. Scientifically, the high standard achieved is especially noteworthy, as is the interest aroused in workers in the most diverse fields—leather chemists, academic organic chemists, and biochemists in all guises, whether concerned with plants or animals, with forest products, fruits, beverages or tobacco. The stimulating contacts thus created are invaluable to all and essential for the progress of this branch of chemistry as a whole.

Agency for Sweden Sought

A Swedish company, Bachner Oil Products AB, is anxious to obtain an agency for British heavy chemicals such as oils, fats, waxes, solvents etc. The company is prepared to buy on its own account and the managing director of the company is prepared to make a personal call on any British company interested. The address of the company will be supplied on request.

Board of Trade Order

Changes in Export Licensing Control

CHANGES in export licensing control are made by a Board of Trade Order which came into force on 4 May 1956. The principal changes are as follows:—licences will not be required (except for exports to China, Macao, Tibet, and North Viet Nam) for the export of chloropicrin; and for the export to the British Commonwealth, the Irish Republic and the US of ferro-molybdenum, ferro-phosphorus, molybdenum metal, alloys and compounds and certain bismuth, niobium and zirconium alloys.

Licences will be required for the export to destinations other than the British Commonwealth, the Irish Republic and the US of specified crystals and lithium compounds; and for the export to all destinations of lithium metal ores, and devices for the detection of noxious gases.

In the main the Order gives effect to changes of detail in the lists of goods controlled for strategic reasons agreed in consultation with other countries who operate similar controls. Similar changes are made in the Transshipment Open General Licence of 8 January 1955, and in the Strategic Goods (Control) Order, 1954 for merchanting transactions.

The changes are made by The Export of Goods (Control) (Amendment No. 4) Order, 1956 (S.I. 1956 No. 576 price 3d by post 4½d); Transshipment Open General Licence Amendment dated April 18, 1956 (price 4d by post 5½d); and The Strategic Goods (Control) (Amendment No. 2) Order, 1956 (S.I. 1956 No. 577 price 3d by post 4½d). Copies of the amendments are obtainable from HMSO, Kingsway, London WC2 and branches.

British Standard

THE British Standards Institution announces the publication of 'British Standard for Iodine Flasks' (BS2735:1956).

Iodine flasks are widely used in analytical laboratories and a standard flask (in two sizes) should be a great help to both manufacturers and users. For flasks used in the determination of iodine values important points are the capacity of the cup top and the design of the long-handled stopper.

The cup top specified in this standard is

wider than those generally used in the past. The advantages of this are that: (a) It is easier to pour from a bottle into the cup, with the stopper in position; (b) it is easier to clean the top of a burette or the vapour tube of a Soxhlet-extractor; and (c) the possibility of damaging the rim of the cup when withdrawing the stopper is greatly reduced.

This British Standard may be obtained from the Sales Branch of the British Standards Institution, 2 Park Street, London W1, price 2s 6d.

New Atomic Site

THE UK Atomic Energy Authority is considering the use of a site at Winfrith, Dorset, for an extension of the type of research activity carried on at Harwell.

If the Authority decides to pursue the possibility of obtaining this site, a series of approvals will be necessary. It will need planning permission from the Local Planning Authority, an Industrial Development Certificate from the Board of Trade, and a licence for the disposal of waste products from the appropriate authorities, according to the method of disposal.

The Authority states that any reports on the use to which the site would be put, if it were decided to use it, are purely speculative. Various possibilities are under discussion within the Authority and no final conclusions have been reached.

Rising Nickel Production

SINCE the war Canadian nickel producers have increased their annual production by about 95,000,000 lb. Of this, The International Nickel Co. of Canada accounted for 55,000,000 lb. This was stated in Toronto recently by Dr. John Thompson, the chairman of The International Nickel Co. of Canada, when announcing a record trading year for the company in 1955.

The year was also a record year for all Canadian nickel producers whose combined output totalled 445,000,000 lb. Of this total, The Canadian Nickel Co. of Canada delivered 290,000,000, or 65 per cent of the western world's supply. Dr. Thompson said that in the last 10 years The International Nickel Co. had spent \$31,000,000 on exploration.

IN THE EDITOR'S POST**Fluoridation of Water**

SIR.—I have no wish to save Mr. P. W. G. Rayner's body, if he wishes to injure it. I never suggested that anyone should be forced to drink fluoridated water. Mr. Rayner will be free to reject it or to injure his teeth in any way he pleases. Nor did I say it was impossible to reject what one knows is good; I doubted the possibility of *not wanting* what one believed to be good for one's *self* (not one's teeth only). A hunger striker rejects something he *wants*, and as a protest, but not a protest against being offered what he thinks is good. This is where Mr. Rayner's attitude was unique. Now, however, he *also* objects to fluoridated water for the opposite reason which by itself would be more comprehensible, that it may be *bad* for him in some way not yet known. However, he might equally well object to any kind of water. The only detectable difference in wholesomeness between water with and without fluorine is the beneficial effect on the teeth of the former. Fluoridation is no longer experimental. The effect of life-long consumption of water of high fluorine content has been thoroughly studied.

Mr. Rayner can exercise his free will by obtaining his own supplies of water privately but he seeks to deny to the rest of the community the exercise of their will to draw fluoridated water from the taps. Because of a quite irrational fear for himself, and from sheer perversity, he expects future generations to sacrifice on the altars of ignorance and anti-science three times as many of their teeth as they need otherwise lose. Is this a moral argument?

I think if Mr. Rayner knew how much suffering was caused by preventable dental decay he would rather regard the present accepted practice of supplying fluorine-deficient water as a 'ghastly failure' and its apologists as the 'inhuman monsters'. I, however, make due allowances for ignorance, stupidity and apathy.

Though a tea drinker, and interested in public health, I am not a civil servant but,
Sir,

Yours truly,

R. B. D. STOCKER.

London, SW10.

Editor's Note : This correspondence is now closed.

First Textile Trades Fair

FEATURED at the first National Industrial Textiles Trade Fair which ended on Friday 27 April at the Royal Albert Hall, London, was a parade of industrial and protective clothing comprising 52 items. The range covered a variety of industries, and prominent among exhibitors were ICI, Courtaulds, British Nylon Spinners, and Siebe, Gorman & Co.

More than 300 firms were represented at the fair, which was initiated to bridge the gap between producers and the industrial users of textiles, and although synthetic fibres were emphasized on the majority of trade stands no fewer than 52 Scottish flax and jute firms were represented. Being shown for the first time at an exhibition in the south was Refrasil, a light-weight silica fibre for high temperature insulation. Made by the Darlington Chemical & Insulating Co., and marketed by the British Refrasil Co. Ltd., of Stillington, Co. Durham, Refrasil was developed in the US by the H. I. Thompson Co., and was designed for use at temperatures up to 1,000°C.

Materials Testing

A COURSE on non-destructive testing of materials will be held by The British Council in London from 4 to 17 November. It is designed to provide a broad survey of work being carried out in the UK on the development of non-destructive testing techniques and of the uses to which they are being put.

The course will consist of a series of lectures and discussions on the following subjects:— methods for the non-destructive testing of materials and components; instrumentation in the field of non-destructive testing; industrial use of non-destructive testing techniques; research work in progress with the object of improving existing techniques and developing new ones. Attention will be concentrated on the following four principal techniques: industrial radiography (particularly the examination of joints and welds); electrical, magnetic and electromagnetic testing; ultrasonic testing; and penetrant testing.

The fee for the course is £41. Applications should be made to the Director, Courses Department, The British Council, 65 Davies Street, London W1.

OCCA Annual Meeting

THE 18th annual general meeting of the London Section of the Oil & Colour Chemists' Association was held at the Criterion Restaurant, Piccadilly Circus, London W1, on 24 April, 1956. The meeting, which was preceded by a dinner, was presided over by Mr. H. A. Newnham.

Proposing the adoption of the annual report, Mr. H. C. Worsdall, hon. secretary, said the growth in size of the technical exhibition brought with it many administrative problems, but the increasing competition for space would be to the advantage of the committee which would then be able to be more selective when considering applications, thus enforcing the desired technical standard.

Seconding the adoption of the annual report, Mr. A. G. North said that while it was encouraging to see that the membership as a whole had risen from 693 in 1954 to 743 in 1955, it was distressing to find that the junior membership had dropped from 15 to 12. He wondered whether it would be possible to improve the facilities in the society for junior members.

Referring to the technical exhibition, Mr. North said there was a large body of opinion which held that one could not successfully bring out new materials every 12 months. That difficulty was accentuated by the fact that data on the material had to be produced some six months in advance for the exhibition brochure. Therefore it might be sensible to hold the exhibition in alternate years and to increase its size and duration accordingly. Another course would be to alternate the site of the exhibition between, say, London and Manchester. Although it would then come out of the province of the London Section it could obviously be worked out on a co-operative basis.

Heat Treatment Practice

A CONFERENCE on heat treatment practice, organized by the British Iron and Steel Research Association, is to be held at Ashorne Hill near Leamington Spa, on 5 and 6 June. The chairman will be Mr. E. W. Colbeck of Hadfields Ltd., and vice chairman Mr. W. C. Heselwood of United Steel Companies Ltd.

The first session will be concerned with distortion and cracking problems. Papers will be delivered by Mr. F. D. Waterfall

(ICI Ltd.) and Mr. P. E. Clary (Ford Motor Co. Ltd.).

Session two, on heating for forging and treatment, will be introduced by a paper from Mr. O. Hirston (Brown-Firth Research Laboratories) on 'The Principles of Equipment to Ensure Good Heat Flow in Furnace Charges'. This will be followed by a paper on 'Heat Flow in Large Forgings' by Dr. F. W. Jones, also of Brown-Firth Research Laboratories.

The third and last session is concerned with transformations. Mr. H. Allsop (Brown Bayley Steels Ltd.) will give a paper on 'Isothermal Transformation Diagrams', and Dr. W. Steven (The Mond Nickel Company Ltd.) will conclude with a paper on 'Continuous Cooling Transformation Diagrams'.

Application forms and full details of the arrangements can be obtained from the organizer and secretary, Mr. J. R. Powell, of the British Iron and Steel Research Association, 11 Park Lane, London, W1.

NBA Elections

AT THE recent annual general meeting in London of the National Benzole & Allied Products Association (NBA), Mr. L. W. Blundell, controller of by-products of the North Thames Gas Board, was elected to succeed Mr. A. K. Steel, of the carbonization department of the NCB, as President of the Association. Mr. Steel was the first president elected when the Association was formed to replace NBA Ltd. in 1954. Mr. Blundell, who was previously vice-president, is succeeded in this office by Mr. H. H. Bates, chairman and managing director of the National Benzole Co. Ltd.

The elected executive committee is as follows: Dr. M. Barash (East Midlands Gas Board), Mr. J. Colligon (Dorman, Long (Chemicals) Ltd.), Mr. F. W. O. Doddrell (NCB, NE Division), Mr. C. M. Frith (South Yorkshire Chemical Works), Mr. R. T. Hayes (United Coke & Chemicals Co. Ltd.), Mr. F. A. Jackman (Carless, Capel & Leonard Ltd.), Mr. C. J. Johnson (North Thames Gas Board), Mr. D. G. Moody (NCB, E. Midlands Division), Mr. W. Robinson (Midland Tar Distillers), Mr. A. Slater (The Staveley Iron & Chemical Co.), Mr. A. K. Steel (NCB), and Mr. J. B. Vickers (Yorkshire Tar Distillers Ltd.).

Safety Notebook

THE National Industrial Safety Conference and Trade Exhibition of industrial safety appliances, organized annually by the Royal Society for the Prevention of Accidents, will be held at Scarborough, from 11 to 13 May, under the chairmanship of Mr. R. E. Tugman, division safety officer, Alkali Division, ICI Ltd. Nearly 600 delegates from all branches of industry are expected to attend, and about 50 manufacturers and organizations will be represented in the trade exhibition.

The presidential address will be given by Sir Howard Roberts, C.B.E., D.L., J.P., and the opening address to the conference will be given by the Rt. Hon. Iain Macleod, M.P., Minister of Labour and National Service. The following papers will be delivered: 'Safety Precautions in the Use of Radioisotopes' by R. J. Sherwood, B.Sc. (Eng.), A.C.G.I., S.M., health physics division, AERE, Harwell; 'Education and Training of Entrants to Industry' by R. G. Bellamy, O.B.E., T.D., M.Eng., M.I.Mech.E., education and training officer, Central Electricity Authority; 'Dust Suppression in Industry' by W. B. Lawrie, M.B.E., M.Sc., F.R.M.S., A.I.M., engineering and chemical branch, Factory Department, Ministry of Labour and National Service; 'Skin Irritants' by C. N. D. Cruickshank, Unit for Research on the Experimental Pathology of the Skin, Birmingham University; 'The Use of Electronics for Safety Devices' by B. G. Higgins, British Thomson-Houston Co. Ltd.

* * *

THE Sir George Earle trophy for industrial safety, which was presented to the Royal Society for the Prevention of Accidents earlier this year by Sir George Earle, chairman of Associated Portland Cement Manufacturers Ltd., for annual award for an outstanding achievement in the cause of industrial accident prevention by any organization or body, has been awarded to HM Inspectors of Factories. According to the citation, the award was made to the inspectors 'in recognition of their many years of outstanding contribution to the prevention of accidents in industry, by their own individual endeavours, their valuable support of the voluntary

accident prevention movement in the UK, and their example, which has been followed by many countries throughout the world.'

The presentation will be made at the society's National Industrial Safety Conference at Scarborough in May. Sir George Barnett, HM Chief Inspector of Factories, will receive it on behalf of his staff.

* * *

A LIGHTWEIGHT, Neoprene sprayed on nylon base boiler suit, giving complete protection for the body, has been developed by Timeg Ltd. This garment, known as the Fury, was exclusively designed and proofed to give protection against every form of acid, oils, chemical fumes, gasoline, kerosene and radioactive dusts. It is claimed that oil does not affect the Neoprene surface. The suit is sewn throughout with Terylene thread and all seams are electronically welded. It has double front fastening (an inside full length zip and an outside stud fastener) and double arm and leg covering to fit over gloves and boots, ensuring no leakages. Ventilated at the back, the suit allows complete freedom of movement. Perspex helmets are supplied in matching materials.

* * *

TWO new types of safety goggles are being incorporated in the range of safety equipment manufactured by Panorama Equipment Ltd. The first is a chemical goggle, with indirect ventilation, which has an injection moulded pvc frame fitted with a shatterproof acetate window. It will fit all size faces, can be worn for many hours at a stretch, and will go over all types of spectacles. The second new goggle conforms to the British Standard Specification for gas welding.

* * *

THE accident frequency rate of ICI's Nobel Division in February was 0.401, only slightly higher than 0.375, the best ever figure returned in January. The best division figure previously was 0.433 for August 1955. For the six months July 1955, until the end of February 1956, the frequency rate was 0.854, an improvement of 27 per cent of the division's previous best six months' figure of 1.170.

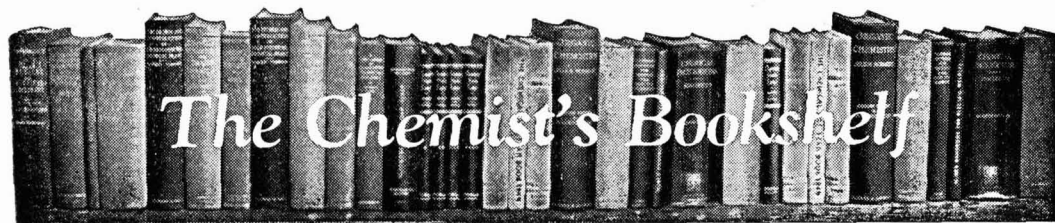

THE CHEMICAL CONSTITUTION OF NATURAL FATS. By T. P. Hilditch. 3rd edition. Chapman & Hall Ltd., London, 1956. Pp. 664. 95s.

The original edition of this important volume on the chemistry of natural fats first appeared in 1940, and was subsequently revised in 1947. Since then additions to our knowledge of the natural fats and their components have made it possible to make the presentation of the subject even more complete. At the same time the author has endeavoured to maintain the comprehensive character of the work and to leave the general plan unaltered.

One of the most marked developments in recent years has been the increase in our knowledge of the component glycerides present in a large number of natural fats. The study of the glycerides present in liquid fats has also received particular attention since 1940, and it is therefore now possible to provide a reasonably complete account of glyceride structure covering the whole range of natural fats. Accordingly, Chapters V (The Component Glycerides of Natural Fats: General Survey), VI (The Component Glycerides of Individual Vegetable Fats) and VII (The Component Glycerides of Individual Animal Fats) have therefore been entirely rewritten. Chapter VIII (Some Aspects of the Biosynthesis of Fats), which formerly surveyed some aspects of the general biochemistry of fats, has now been restricted to a consideration of the possible means by which fats may be synthesized in living tissues, and when dealing with animals, how they may be derived from fat already present in the diet.

In recent years our knowledge of the constitution of individual natural fatty acids has been very considerably advanced. Many general methods for the formal synthesis of long-chain saturated and unsaturated acids

have been described in the literature and a number of natural unsaturated members have now been prepared synthetically by alternative methods. In view of these developments, Chapter IX (Constitution of Individual Natural Fatty Acids) has been largely rewritten, the individual unsaturated acids being grouped largely according to their structural resemblances to one another.

Chapter XI (Notes on Experimental Technique Employed in the Quantitative Investigation of Fats) has also been altered so as to emphasize the most recently developed procedures, such as the use of crystallization from solvents at low temperatures, and the spectrophotometric determination of certain unsaturated acids, e.g., linoleic, linolenic and elaeostearic.

Prof. Hilditch's manual has for some time been a standard work on the chemistry of natural fats, and the new revised and enlarged edition fully maintains the standard set in the original volume.—G.S.E.

PHYSICAL CHEMISTRY. By W. J. Moore. 2nd edition. Longmans, Green & Co. Ltd., London, 1956. Pp. xii + 663. 30s.

There are at least two methods of approach to the writing of a text book on physical chemistry. The author may begin with the atom and radioactivity and proceed by way of the electronic theory to molecules, states of matter and more specialized topics, introducing thermodynamics at some point in the text and using it in later discussion. Alternatively, thermodynamics may be discussed at the outset and its methods used throughout. The second method, which has much to commend it, is used by the author of this book which is of advanced character, requiring a prior knowledge of simpler calculus, physics and chemistry.

The first four chapters provide an adequate basis of classical thermodynamics and are followed by a concise account of changes of state. A chapter on solutions and phase equilibria seems rather sketchy. Treatments of fractional distillation, colligative properties and three-component systems are brief and it is surely time that mention should be made of osmotic methods used in the determination of molecular weights of macromolecules, in addition to those of historical interest.

Three chapters are concerned with atomic structure, nuclear chemistry and physics and with particles and waves. The development of the nuclear theory, radioactivity, the nature, detection and separation of isotopes are considered and methods of artificial disintegration, elementary particles, the nucleus and nuclear reactions discussed. The chapter on particles and waves indicates the dual character of light and gives an account of the Bohr atom and of atomic and X-Ray spectra, leading to a very clear exposition of wave mechanical principles which includes derivation and solution of the Schrodinger equation and consideration of its implications.

A chapter on molecular structure includes the development of valency theory, the molecular orbital and valence bond methods, resonance, dipole moments, magnetism in relation to molecular structure, molecular, Raman and microwave spectra and bond energies. Another gives a very clear and readable account of chemical statistics in which statistical methods are considered, the Boltzmann distribution derived and partition functions explained. The relationships between statistical and thermodynamic quantities are clearly shown and quantum statistics are discussed. Two further chapters deal with crystals and liquids. The former includes brief accounts of the band model, semi-conductors, Brillouin zones and alloy compounds and the latter theories of liquid structure, intermolecular forces and viscosity.

The remainder of the book is concerned with more specialized topics. The treatment of electrochemistry is rather brief, but concise, in parts although the Debye-Huckel theory is considered in detail and its limiting law derived. Amphoteric electrolytes and the role of the solvent in determining the strength of acids and bases are not considered. A chapter on surface chemistry,

in contrast to others, seems very sketchy. Perhaps, as the author says, a fairly comprehensive account of colloidal systems would require a book at least as large as that under review but it seems a pity that emulsions, gels and foams are only mentioned and that lyophilic sols and colloidal electrolytes are not considered. Multimolecular adsorption is only briefly considered but the Langmuir theory is discussed in some detail. On the other hand, the chapters on chemical kinetics and on photochemistry and radiation chemistry provide fairly detailed and up-to-date accounts.

The text is lucid and precise, important relationships are generally derived without ambiguity from fundamental principles and diagrams are clear. Each chapter is followed by problems which have been carefully chosen to aid understanding and brief consideration or omission of certain topics is mitigated by lists of suggested additional reading. As is stated on the dust cover, the book is well suited to the physical chemistry syllabus of a B.Sc. Honours Degree in chemistry. The statement that students buying it should not need to purchase any other book of theoretical physical chemistry is probably true providing that it is supplemented by reading and lectures on certain topics. It provides a good account of much modern physical chemistry, not only for students of pure chemistry but also for those of chemical engineering and for industrial chemists generally. For a book of this type the price is very reasonable.—W. R. MOORE.

Fixed Assets Increased

THE consolidated fixed assets of Brotherton & Co. expanded from £1,398,754 to £2,522,554 in 1955. Old plant has been replaced and manufacturing capacity extended. The extension to the central research laboratories has been doubled.

Work in progress on buildings and commitments for capital expenditure in the holding company amounted to £549,000, a large part being for a new office block.

Investments are being realized to pay for these capital developments. The group's holdings have been reduced from £1,557,167 to £582,799. The chairman Mr. B. L. Ratcliffe, pointed out that investment revenue would be reduced but its place would be taken by increased revenue from trading.

HOME

Refined Esparto Wax

Chas. H. Windschuegl Ltd. announces that it is now marketing super refined esparto wax, produced from the esparto wax manufactured by Tullis Russell & Co. Ltd.

Glasgow Welding Exhibition

An exhibition of welding equipment, organized by Quasi-Arc Ltd., will be held at the Scottish Electricity Board, Hawick Street, Yoker, Glasgow, from 24 May to 1 June. The Sigma spot welder for making spot welds in mild steel from one side only will be demonstrated for the first time.

du Pont Agents

Brown & Forth Ltd. of Euston Road, London NW1, who are sole distributors in the UK and Eire for the organic chemicals department and the textile fibres department of E.I. du Pont de Nemours & Co., have been appointed distributors for the products manufactured by the electrochemicals department, which include Darvyl L-lysine monohydrochloride, polyvinyl alcohol, and vinyl polymer.

Glossy US Textbooks Too Slick—ICI Chief

Speaking at the recent annual dinner of the Society of Dyers and Colourists in Manchester, Mr. Clifford Paine, M.Sc., A.M.C.T., the development director of ICI Ltd., said: 'I'm a little dismayed to find the growing number of glossy American textbooks appearing on the shelves of science libraries in London and the provinces. They are too slick, and lack that feeling for science and technology which the best British textbooks in the past have been able to produce.'

ICI Chief Conference Chairman

Mr. R. E. Tugman, division safety officer of the Alkali Division of ICI Ltd., will be chairman of the National Safety Conference & Trade Exhibition organized by the Royal Society for the Prevention of Accidents to be held at Scarborough, Yorkshire, from 11 to 13 May. On the second day Mr. W. B. Lawrie, M.B.E., M.Sc., F.R.M.S., A.I.M., of the engineering and chemical branch of the Ministry of Labour, will present a paper, 'Dust Suppression in Industry'. Dr. C. N. D. Cruickshank, of Birmingham University, will follow with a paper entitled, 'Skin Irritants'.

Change of Address

The Minerva Detector Co. Ltd. has moved to Lower Mortlake Road, Richmond, Surrey (telephone: Richmond 6431).

Exhibition Postponed

The British Colour Council announces that its exhibition marking 25 years of colour service, 'A Story in Colour', which was due to open on 8 May, is postponed to the week of 24 September, when a conference on colour will also take place.

Trade Name For Polyvinyl Acetate

British Oxygen Chemicals Ltd. announce that their polyvinyl acetate (pva) will in future be known as Vandike. The different British Oxygen pva emulsions will be labelled Vandike 500, Vandike 1,100 etc., indicating the specification to which the emulsion has been prepared.

Annual Meeting & Dinner

The 37th annual general meeting and dinner of the chemical engineering group of the Society of Chemical Industry will be held at the Café Royal, Regent Street, London, on 30 May. Applications for tickets (price 27d 6d each) should be made to Mr. R. C. Odams, the honorary secretary, at 56 Victoria Street, London SW1.

Gift to Technical College

A gift of £5,000 to endow a scholarship in chemistry or chemical engineering at Bradford Technical College has been made by Mr. Fred Ellison, of Yorkshire Tar Distillers Ltd. Mr. Ellison said he made the gift because he was conscious of the need for technologists and wished to pay a tribute to the college where he was trained in chemistry.

Joint Meeting

The 54th ordinary meeting of the Physical Methods Group of the Society for Analytical Chemistry will be held jointly with the Photoelectric Spectrometry Group on 25 May at 2.30 p.m. in the Physical Chemistry Laboratory, South Parks Road, Oxford. The subject will be 'Nuclear and Para Magnetic Resonance' and the programme will include a laboratory visit and the presentation of three papers.

. OVERSEAS .

Orlon Output Suspended

Du Pont have suspended the production of Orlon filament yarn at the Camden, South Carolina plant as the volume of business so far this year has been insufficient to operate the plant.

Egypt To Step-Up Fertilizer Production

The fertilizer factory at Suez, Sté. Egyptienne d'Engrais et d'Industries Chimiques SAE, is to increase its capacity to produce an additional 100,000 tons of sulphate of ammonia annually.

US Arsenic Output

US domestic production of white arsenic in 1955, was 10,800 short tons, comprising 10,000 tons of crude and 800 tons of refined arsenic. Output decreased 18 per cent from the 13,200 tons in 1954, and 27 per cent from the 1946-50 average (14,700 tons). Arsenic metal was not produced in 1955.

Storage Silo Completed

A 25,000-ton cargo silo for ammonium sulphate has been completed by Fertilisers & Chemicals Co. near Haifa, Israel. It was built by Solel Boneh, the Histadrut construction corporation, with the co-operation of experts of the British Cementation Co., at a cost of £1,000,000.

Lithium Carbonate Plant

Montgary Explorations and the Kawecki Chemical Co. are to erect a plant in or near Winnipeg to treat the Montgary lithium ores. The plant will have a capacity of 2,000,000 lb. of lithium carbonate per year. The Kawecki Company has developed a new process for the production of lithium carbonate.

Nylon Trousers Test

A 70 per cent increase in the wear life of denim trousers results from a warp construction containing 25 per cent nylon, according to tests recently completed by the du Pont Co. in the US. Conducted among 18 workmen over a period of two-and-a-half years, the test showed that the average wear life of the nylon-reinforced trousers was 228 days, compared with 124 days for conventional work trousers of the same weight and construction.

Imperial Oil Expansion

Imperial Oil, an affiliate of the Standard Oil Co. of New Jersey, is to spend £714,000 on a programme of improvement at its Montreal East refinery.

Jordan Potash

The Jordan Government is to execute the Jordan potash and Dead Sea minerals project solely as a domestic scheme and is to provide £450,000 in the annual budget for this purpose. This was decided after it had been revealed that other Arab governments would not participate in the project.

Celanese Expansion

Celanese Corporation of America announces that construction is under way on a major expansion of its Bishop, Texas, chemical plant to increase by 25 per cent production of formaldehyde, methanol acetaldehyde and certain other organic chemicals. The new facilities are expected to come on stream early in 1957.

Texas 'Science City'

A \$50,000,000 'science city' is to be built on 3,000 acres on the outskirts of San Antonio, Texas. It will include research facilities, residential and recreational areas. Forty large plots have been set aside within the grounds of the science city for industrial research laboratories and high level, technical manufacturing plants. Laboratories will be built to meet specific industrial needs and will be available on a long-term basis or companies may lease the land and build their own laboratories.

Chemical Investment Plan

Proposals for the investment of £150,000,000 in the next five years in the development of the chemical industry have been put forward in Hungary, it is reported. The chemical industry must be developed 'most rapidly', the plan says. Its biggest feature is the completion of the fertilizer and plastics basic materials combine at Tiszapalkonya, which will process natural gas piped from Roumania. It is planned to multiply the 1955 output of nitrogenous fertilizer seven times by 1960 and to double phosphorus fertilizer output. Plastics materials production per head of population is to be raised to 2½ lb., more than four times the 1955 level.

PERSONAL

MR. F. GORDON KAY, A.M.I.Mech.E., sales manager of Acheson Colloids Ltd., of London, has left for an extensive tour of South America. He will visit Brazil, Uruguay, Argentina, Paraguay, Chile, Peru, Colombia and Venezuela, and will cover over 22,000 miles by air during a three months' tour. The object of Mr. Kay's visit is to establish sales organizations for 'dag' dispersions of colloidal graphite and molybdenum disulphide in the principal industrial centres in the South American Continent.

At the annual general meeting of the Society of Glass Technology at Sheffield on 25 April, DR. J. H. PARTRIDGE, D.Sc., Ph.D., F.S.G.T., was elected president in succession to SIR GRAHAM CUNNINGHAM. Prior to the election of the president, Sir Graham, DR. B. P. DUDDING, and MR. EDWARD MEIGH were elected honorary fellows and presented with illuminated letters. Following the meeting Dr. Partridge presented his Presidential Address on 'Research & Common Sense in the Glass Industry'. Other papers presented were: 'Some Problems Relating to the Constitution of Liquid Slags' by PROFESSOR R. HAY (prepared jointly with DR. P. T. CARTER), and 'High Temperature Glass Fibres' by DR. ALEXANDER SILVERMAN, Emeritus-Professor of Chemistry at the University of Pittsburgh. Dr. Partridge, the new president, has been a member of the Council of the Society of Glass Technology, a vice-president, and for several years has served on the Society's committees.

MR. RICHARD FENTON, vice-president of Pfizer International Subsidiaries, has been elected to the board of directors of Pfizer International, it is announced from New York by JOHN J. POWERS, JR., president and chairman of the board. Mr. Fenton, whose headquarters are in New York City, supervises Pfizer operations in Europe, Africa, and the Middle East. He first joined Pfizer, the international pharmaceutical organization, as British branch manager in September, 1951, to help start operations in Great Britain. Born in London, he received an M.A. degree from Cambridge. Before his association with Pfizer he was assistant to the managing director of British Schering Ltd. and during World War II, he served

with the Department of Economic Warfare in the Foreign Office. Mr. Fenton now lives with his wife and two daughters in Alpine, New Jersey.

MR. D. R. MACKIE has been appointed managing director of Monsanto Chemicals Ltd. Mr. Mackie, who has been acting managing director since November 1955, was appointed a director of the company in 1952 and commercial director in 1953. In May of this year he will have completed 32 years' service with the company.

At a recent meeting of the Royal Society the following were elected Foreign Members of the Society:—KAI ULRIK LINDERSTOM-LANG (Copenhagen), who is best known for his contribution to protein chemistry and for his pioneer development of ultra micro-techniques for the biochemical study of the localization of enzymes in tissue cells; ROBERT BURNS WOODWARD (Cambridge, US), distinguished for his investigations in organic chemistry especially on the synthesis of important natural products such as quinine, cortisone and antibiotics; and FRITZ ZERNIKE (Groningen), known for his researches in phase-contrast microscopy.

MR. CLAUD B. BARRETT has been appointed a director of The Texas Company. Mr. Barrett joined the company as a salesman in Atlanta in 1927. In August 1938 he was made manager of the southern territory at Houston, Texas.

MR. E. WOOLDRIDGE, chief accountant of the Greengate & Irwell Rubber Co., has been appointed to the board. He succeeds MR. DENNIS FRANKENBURG who has resigned.

Will

MR. GEOFFREY ELIOT HOWARD, of 43 Egerton Crescent, London SW3, formerly of Ashmore near Salisbury, Wiltshire, and Ilford, Essex, chairman of Howards of Ilford Ltd., a member of the council of the Association of British Chemical Manufacturers, a director of Baird & Tatlock (London) Ltd., Hopkin & Williams Ltd., and other companies, who died on 16 January, aged 78 years, left £52,483 15s 7d gross, £48,470 3s 8d. net value. (Duty paid £17,031).

Mobile Elevator

Rates of up to 4½ tons per hour claimed

AN elevator that can lift powdered or granulated material to a height of five feet or so in quantities up to 4½ tons per hour has been designed by Westhurst Ltd., an associate of Russell Constructions Ltd.

The elevating elements consist of a 'V' rope type rubber-canvas endless belt into which stainless steel spindles are fitted. These spindles carry the 'flights' which can be supplied in either polythene or rubber. Using these flights the elevator works on the mass flow principle. In cases where the mass flow principle cannot be applied, a bucket attachment can be fitted. It is claimed that an accurate rate of flow can be obtained by this method.

The cross section of the elevator tunnel is 4½ by 4½ inches and elevator speeds of five to 32 feet per minute are obtainable. Using the bucket gear accurately gauged flows up to 10 cwt per hour can be obtained, while up to 4½ tons per hour can be obtained with mass flow.

Power is provided by a ¾ HP electric motor fitted with reversing gear.

An important feature of the elevator belt is that it contains no cavities or articulated parts which could harbour dirt or be contaminated by attrition.

The side panels of the chassis are fitted with quick release clips. When the unit requires cleaning these panels can be detached and the elevator belt and its pulleys removed in three or four minutes. This dismantling can be carried out without the use of tools, thus eliminating the necessity of calling upon factory maintenance staff.

All rotating parts are mounted upon a special type ball race in which the possibility of contamination of the material being carried is reduced to a minimum.

The entire unit weighs only three cwt and is mounted on wheels for easy manoeuvrability.

New Polythene Monofil

A NEW type of polythene monofil fibre known as Courlene X3 has been developed by Courtaulds. This material differs from standard Courlene in its strength and abrasion resistance which are claimed to be comparable with those of polyamide fibres such as nylon.

The softening point of the new material is

about 120°C as against about 90°C for standard Courlene, and the melting point is 135°C. Fabrics made from it can therefore be boiled without suffering any damage. The high chemical resistance of polythene makes this material very suitable for protective clothing. Other possible uses include filter cloth and ropes for use in wet, cold or tropical conditions.

Photo-degradation properties are believed to be slightly inferior to standard Courlene but Courtaulds hope to overcome this difficulty very shortly.

At present limited quantities of Courlene X3 are available in clear and white grades but coloured monofils will be manufactured in the near future.

ICI Ltd.'s Record Sales

CONSOLIDATED sales of ICI Ltd., for 1955 amounted to £411,000,000 to establish a record for the company. Group income, before taxation, totalled £53,579,085 after charging £20,379,824 for depreciation. The net income of the company for the year 1955 is £23,977,163, and the total available for appropriation, including £4,475,733 brought forward from the previous year, is £28,452,896. The directors recommend a final dividend on the ordinary stock of six per cent, less tax at the UK standard rate for 1956/57, making with the interim of four per cent a total of 10 per cent for the year.

M & B Honour Agents

EMBASSY and consular officials of Denmark and Norway attended a celebration dinner given by May & Baker Ltd, at Café Royal, London, on 24 April. The dinner was to mark the 50th anniversary of the appointment of May & Baker's Danish and Norwegian agents, Firma Ringsted & Semler of Copenhagen, and Firma G. O. Johnsen of Oslo.

Mr. C. A. O. Rideal, sales director of May & Baker presented the directors of the two agencies with silver cigarette boxes. The principal guests were, Mr. Frithjof Johnsen, of Firma G. O. Johnsen, Mr. Aage S. Nilsson of Firma Ringsted & Semler, Mr. Aksel Christiansen, consul general, Danish Embassy, Mr. H. Agerbak, counsellor for press and cultural affairs, Danish Embassy, and Mr. T. L. Paus, economic counsellor, Royal Norwegian Embassy.

Law & Company News

Commercial Intelligence

The following are taken from the printed reports, but we cannot be responsible for errors that may occur.

Mortgages & Charges

(Note.—The Companies Consolidation Act of 1908 provides that every Mortgage or Charge, as described herein, shall be registered within 21 days after its creation, otherwise it shall be void against the liquidator and any creditor. The Act also provides that every company shall, in making its Annual Summary, specify the total amount of debt due from the company in respect of all Mortgages or Charges. The following Mortgages or Charges have been so registered. In each case the total debt, as specified in the last available Annual Summary, is also given—marked with an *—followed by the date of the Summary but such total may have been reduced.)

CHINNOR CEMENT & LIME CO. LTD. London EC.—22 March, deed of modification and charge by way of collateral security for £100,000 debenture stock created by Chinnor Industries Ltd. and secured by a Trust Deed dated 30 October, 1936, and supplemental deed dated 9 May, 1950; charged on leasehold Highfields, 3 Wykeham Rise, Chinnor. *Nil. 15 December, 1955.

ESPERANZA COPPER & SULPHUR CO. LTD. London EC.—23 March, £200,000 debenture stock secured by a Trust Deed dated 15 March, 1956; charged on specified shares and a general charge. *Nil. 11 February, 1955.

HARTON DYEWORKS LTD. Newcastle-on-Tyne.—28 March, £1,700 mortgage, to South Shields Commercial Permanent Building Society; charged on 156/158 High Street, East Wallsend. *£14,319. 13 May, 1955.

HICKS & WEATHERBURN LTD. Leeds, paint manufacturers.—27 March, £4,500 charge, to Mrs. H. E. Nelson, Leeds; charged on Lawnswood Memorial Works, Otley Road, Adel, Leeds. *Nil. 5 December, 1955.

Satisfaction

KEMPSON & CO. LTD. Derby, chemical manufacturers etc.—Satisfaction 28 March, of amount outstanding 1 July, 1908, and of mortgages registered 14 January, 1915, and 27 December, 1918 (two).

Increases of Capital

J. E. CLAPHAM (WATFORD) LTD., manufacturers of printing inks etc., Station Estate, Balmoral Road, Watford, increased by

£49,500 in £1 shares beyond the registered capital of £500.

WOOD TREATMENT LTD., Dane Mills, Bosley, Macclesfield, increased by £50,000, in £1 'B' ordinary shares beyond the registered capital of £31,000.

TRI CHEM LTD., manufacturers of inks etc., Bilbao House, New Broad Street, London EC2, increased by £900 in £1 shares beyond the registered capital of £100.

New Registrations

Plant Medicinals Ltd.

Private company. (564,522). Capital £100 in £1 shares. To carry on the business of manufacturing and pharmaceutical chemists etc. Directors: W. C. B. Plant and Hilda G. Godley. Registered office: 93 Walworth Road, London SE17.

C. J. Schofield Ltd.

Private company. (563,410). Capital £100. To carry on the business of manufacturing chemists and drysalts etc. Directors: Josiah Sargent and Sydney M. Grimshaw. Registered office: Manox House, Miles Platting, Manchester.

Kelemanic Engineering, Ltd.

Private company. (564,573). Capital £100 in £1 shares. To carry on the business of chemical, electrical and mechanical engineers etc. Directors: Georges L. Tixerant, director of Elcot's Ltd., and John A. Steemson, director of Abilly Ltd. Registered office: 37 King Street, London WC2.

Bradford Chemical Co. Ltd.

Private company (564,770). Registered 16 April. Capital £100 in £1 shares. Objects: To carry on the business of manufacturers of and dealers in dyestuffs, chemicals, gases, drugs etc. Subscribers (each with one share): John K. Read, 31 Ivegate, Bradford, solicitor, Mrs. Irene Spencer, 52 St. Leonards Grove, Girdlington, Bradford 8, Allied Colloids (Bradford) Ltd., Badische Anilin-Und Soda-Fabrik AG, each shall have the right to appoint not more than two directors. (The first directors are not named). Solicitors: Cawthron Priddin & Read, Bradford. Reg. office; Royal Exchange Chambers, 61 North Parade, Bradford.

Preston Products Ltd.

Private company (564,837). Registered 17 April. Capital £400 in £1 shares. To carry on the business of manufacturers of and dealers in soaps, soap powders, bleaching powders, washing materials, detergents etc. Directors: Arthur V. Sharples and Dorothy Sharples, of Parkside, Garstang Road, Preston; W. D. Margerison, 88 Higher Road, Longridge, Preston, and W. W. M. Margerison, 53 Highgate, Penwortham, Preston. Reg. office: Leighton Street, Preston, Lancashire.

Company News

Bakelite Ltd.

In his speech at the recent annual general meeting of the company in London, Mr. H. V. Potter, B.Sc., F.R.I.C., M.I.Chem.E., F.P.I., the chairman, said that the company's sales in 1955 were a record, but that increasing costs were causing concern. During the year the company promoted sales drives on the Continent, South Africa and the Belgian Congo, and although production was becoming more competitive in these areas, the most serious threat to Bakelite's export trade was from rising costs at home. A programme has been approved for increasing the capacity for producing industrial and decorative laminated materials, and preparations are under way for the installation of a plant for compounding polythene, and for the improvement of the vinyl resin plant. Mr. Potter, when discussing the subsidiary companies, said that the associated company, Synthetic Chemicals Ltd., had met initial production troubles, but that the company would shortly be producing synthetic phenol on a substantial basis. The trading profit for 1955 was £645,725, as against £648,829. After providing for debenture stock interest and taxation and adding the balance brought forward from the previous year there is a balance of £535,123 out of which £171,000 has been transferred to reserves and provisions. The proposed final dividend of 11 per cent, less tax, together with the interim dividend of five per cent, less tax, already paid, makes a total of 16 per cent, the same as last year.

Cerebos Ltd.

Consolidated trading profits for Cerebos Ltd. advanced from £1,766,492 to £1,835,394 and the net profit from £630,718 to £714,658

during 1955. The dividend was repeated at 30 per cent. The consolidated net current assets are £446,492 higher at £1,954,280, and capital commitments at approximately £450,000 are £180,300 higher. The company meeting will be held at Cerebos House, London NW10, on 17 May at noon.

Market Reports

LONDON.—The movement against contracts has been fully maintained during the past week with a steady flow of new business from the home consuming industries. Export interest is also sustained and a good volume of overseas enquiry is in circulation with buyers seeking competitive quotations. Prices remain steady at recent levels, but the lead compounds are again lower. As from 26 April the basis price for dry white lead is £145 15s; red lead £140 10s and litharge £142 10s per ton. Most of the coal tar products are firm and there is a brisk demand for phenol and cresylic acid.

MANCHESTER.—Steady trading conditions have been reported this week on the Manchester market for heavy chemical products. Delivery specifications under contracts from the textile and allied industries, as well as from most other industrial users, are circulating satisfactorily and replacement business is coming forward as the need arises. Prices are pretty well maintained throughout the range, the outstanding exception again being sulphate of copper, which is cheaper at £110 15s. There is a steady call for the general run of fertilizers, and ready outlets continue to be found for the light and heavy tar products.

GLASGOW.—Business has been reasonably steady during the past week, both in regard to spot and contract deliveries. The increase in rail and road freights are having an effect on prices generally. It has to be reported, however, that copper sulphate prices have again fallen. The demand for fertilizers continues to show improvement in relation to seasonable demands. The export market remains fairly active, with the usual varied range of enquiries being received.

Canada's cement production in 1955 rose to the record figure of 25,184,050, barrels, compared with 22,604,723 barrels in 1955. Deliveries were also a record, amounting to 25,160,538 barrels.

PERMUTIT

ION EXCHANGE MATERIALS

Ion Exchange today performs many tasks in industry, and Permutit manufactures a wide range of these materials. Their application in roles distinct from water treatment has resulted in the development of numerous new industrial processes giving improved results and lower running costs. Some of the materials now available, with their characteristics, are shown below.

- ZEO-KARB Na** A sulphonated coal product containing both strong and weak acid groups.
- ZEO-KARB 215** A nuclear sulphonated phenol resin containing also hydroxyl groups.
- ZEO-KARB 225** A unifunctional cross linked sulphonated polystyrene resin in bead form of high capacity and exceptional chemical and physical stability.
- ZEO-KARB 226** A unifunctional cross linked methacrylic acid resin in bead form containing only carboxyl groups as the ion active groups.
- DE-ACIDITE E** A high capacity anion exchange material of medium basicity.
- DE-ACIDITE FF** A unifunctional very highly basic anion exchange resin in bead form based on cross linked polystyrene and containing quaternary ammonium groups.
- DE-ACIDITE G** A unifunctional weakly basic exchange resin in bead form based on cross linked polystyrene and containing diethylamino groups.
- DE-ACIDITE H** A material similar to "De-Acidite G" but containing dimethylamino groups.
- BIO-DEMINKROLIT** A mixed cation and anion exchange resin for demineralisation in a single column.
- DECALSO F** A synthetic sodium aluminium silicate suitable for the separation and concentration of vitamins and hormones.
- DECOLORITE-ASMIT** A resin of high porosity for removing colour from solutions.
- PERMAPLEX C-10** A highly selective cation exchange resin membrane containing SO_3H groups.
- PERMAPLEX A-10** A highly selective anion exchange resin membrane containing quaternary ammonium groups.

For full technical information please write to:—

THE PERMUTIT COMPANY LIMITED

Dept. V.A. 150, Permutit House, Gunnersbury Ave., London, W.4. Tel: CHIswick 6431

Next Week's Events

MONDAY 7 MAY

The Chemical Society

Galway: University College, 7.45 p.m. 'Seaweeds & Their Utilization' by Dr. F. N. Woodward, B.Sc., F.R.S.E., F.R.I.C.

SCI (London)

London: Rooms of The Chemical Society, Burlington House, Piccadilly W1, 6.15 p.m. Annual general meeting; 'The Radiochemical Centre at Amersham' by W. P. Grove, Ph.D., F.R.I.C.

TUESDAY 8 MAY

Society of Instrument Technology

Manchester: College of Technology, 7.30 p.m. Annual general meeting; 'Chemical Balances' by Dr. G. F. Hodsmen, Ph.D., B.Sc., A.Inst.P.

WEDNESDAY 9 MAY

SCI (Food Group)

London: Rooms of The Chemical Society, Burlington House, Piccadilly W1, 6.45 p.m. Annual general meeting; 'National Taste & National Waste' by Norman C. Wright, C.B., D.Sc., Ph.D., M.A., F.R.I.C.

Society of Instrument Technology

Newcastle-on-Tyne: Stephenson Buildings, King's College, 7 p.m. Annual general meeting.

FRIDAY 11 MAY

Society for Analytical Chemistry

Edinburgh: George Hotel, George Street, 7 p.m. 'Complexones' by R. E. Stuckey, Ph.D., B.Sc., F.P.S., F.R.I.C.

SCI (Glasgow)

Glasgow: Royal Technical College, George Street, 7.15 p.m. Young members'

meeting in conjunction with the food group. 'The Irradiation of Butter with High Energy Cathode Rays' by Miss M. Cameron (The Royal Technical College, Glasgow); 'Paper Chromatography of Organic Acids' by A. L. Cochrane (The Distillers Co. Ltd.); 'A Growth Method for the Evaluation of Proteins' by B. H. Doell (Bovril Ltd.); and 'Ultrafiltration & Dialysis in the Estimation of Some Soluble Constituents of Milk' by D. T. Davies (Hannah Dairy Research Institute).

SCI (Microbiology Group)

Cambridge: Visit to the Low Temperature Research Station, University of Cambridge & DSIR, Downing Street, Assemble at research station at 11.45 a.m.

SATURDAY 12 MAY

SCI (Glasgow)

Ayr: Young members' meeting. Visit to the Hannah Research Institute, Kirkhill, Ayr. Bus leaves Royal Technical College, Glasgow at 9 a.m.

Research Prediction

INDUSTRIAL and scientific research in the US this year may cost \$4,500,000,000, predicts the Battelle Institute. Recent estimates place US research expenditure last year at approximately \$4,100,000,000, \$350,000,000 more than in 1954. Battelle Institute statistics reveal that US industry spends an average of two per cent of its gross income on research, and that fast growing industries like aircraft, plastics and chemicals spend up to 10 per cent of their sales dollars on research.

**DO
NOT
FORGET
TO RESERVE YOUR
SPACE IN
THE CHEMICAL AGE
YEAR BOOK**

KEEBUSH

Keebush is an acid-resisting constructional material used for the construction of tanks, pumps, pipes, valves, fans, etc. It is completely inert to most commercial acids; is unaffected by temperatures up to 130°C; possesses a relatively high mechanical strength, and is unaffected by thermal shock. It is being used in most industries where acids are also being used. Write for particulars to—

KESTNER'S

5 Grosvenor Gardens, London, S.W.1

**TITRATIONS
IN
NON-AQUEOUS
SOLVENTS**

A new B.D.H. Booklet

A newly published B.D.H. booklet is available free of charge to laboratories interested in the subject of titrations in non-aqueous solvents, a method which is proving increasingly useful in many fields of analysis.

Selected or specially prepared B.D.H. reagents and indicators are supplied for non-aqueous titrations.

BDH

THE BRITISH DRUG HOUSES LTD.

B.D.H. LABORATORY CHEMICALS GROUP

POOLE

DORSET

CLASSIFIED ADVERTISEMENTS

SITUATIONS VACANT

The engagement of persons answering these advertisements must be made through a Local Office of the Ministry of Labour or a Scheduled Employment Agency if the applicant is a man aged 18-64 inclusive, or a woman aged 18-59 inclusive, unless he or she, or the employment, is excepted from the provisions of the Notifications of Vacancies Order, 1952

THE ATOMIC WEAPONS RESEARCH ESTABLISHMENT, ALDERMASTON, BERKSHIRE, requires

SCIENTIFIC AND EXPERIMENTAL OFFICERS

SCIENTIFIC OFFICER (REF. 1128/38). To join a team investigating the use of natural and synthetic rubber in the Atomic Energy field. Duties will include an advisory service on the use of natural and synthetic rubber compounds and adhesives, particularly in engineering applications. Candidates should possess a First or Second-Class Honours Degree, preferably with A.I.R.I. or A.N.C.R.T.

Salary will be assessed according to age, qualifications and experience within the scale £528-£948 per annum. At present the rates for women are slightly lower.

EXPERIMENTAL OFFICER (REF. 1129/38). Duties will include an advisory service in the Plastics and Adhesives field and development work with new materials. Candidates should possess the minimum qualification of H.N.C. in Chemistry, although a pass degree or A.R.I.C. is preferred. They should be at least 26 years of age and should have a good fundamental knowledge of the high polymers, together with practical experience of thermo-plastic and thermo-setting resins. Salary: £808-£988 per annum. At present the rates for women are slightly lower.

Contributory Superannuation Scheme. Successful married officers now living outside the Establishment's transport area will be eligible for housing on one of the Authority's estates; until housed a lodging allowance may be payable; alternatively, assistance towards legal expenses incurred in house purchase may be available.

Requests for application forms by

POSTCARD

to:

SENIOR RECRUITMENT OFFICER,

at the above address, not later than May 9th, 1956, quoting the appropriate reference number.

CHEMICAL ENGINEERS AND INORGANIC CHEMISTS FOR CANADA

UNIVERSITY Graduates in Chemical Engineering and Chemistry required for Aluminium Company in Canada. Excellent salary, assisted passages, pension and life assurance plan. Write to

**BOX V.770, c/o STREETS,
110, OLD BROAD STREET, E.C.2,
for interview in London.**

ENGINEERS: Applications are invited from qualified Mechanical Engineers (Preferably A.M.I. Mech.E.) for a number of permanent and pensionable appointments at Fort Dunlop. Industrial experience of plant layout and mechanical handling systems is desirable: knowledge of Work Study techniques an advantage. These positions provide excellent scope for advancement in an expanding Company with world-wide interests. Please write, giving age, qualifications, experience and salary required, to the **PERSONNEL MANAGER, DUNLOP RUBBER CO., LTD., FORT DUNLOP, ERDINGTON, BIRMINGHAM 24.**

MECHANICAL AND CHEMICAL ENGINEERS

COURTAULDS LIMITED, Chemicals Division, requires a **GRADUATE MECHANICAL ENGINEER** and a **CHEMICAL ENGINEER** for investigational and development work near Manchester. The work is of an original nature in connexion with the development of chemical plants and processes for which a real interest in, and potential talent for, engineering development work as applied to large-scale chemical plant is of paramount importance. The Mechanical Engineer must have served an apprenticeship for at least two years and all candidates must have had practical works experience. Honours degree men preferred. Age 25 to 35.

Candidates should write for a detailed form of application to the Director of Personnel, Courtaulds Limited, 16 St. Martins-le-Grand, London, E.C.1., quoting the reference H.10 for the Mechanical Engineer and H.11 for the Chemical Engineer.

NATIONAL COAL BOARD

(South-Western Division)

APPLICATIONS are invited for the following posts for research work at the Board's Tar Distillation Plant, Caerphilly, near Cardiff.

SCIENTIST, GRADE 2 (MALE),

(Salary Scale, £925 by £35 to £1,300)

Candidates should hold a good Honours Degree in Chemistry and have had practical experience of tar distillation or petroleum refining, with knowledge of some of the following: High efficiency fractionation—Phenol recovery—naphthalene production—road tars—emulsions—waterproofing compounds—wood preservatives—insecticides, etc. Research experience essential.

SCIENTIST, GRADE 3 (MALE),

(Salary Scale, £575 by £30 to £1,050)

Applicants should have a good Honours Degree in Chemistry, preferably with some industrial experience (not necessarily of research).

SCIENTIFIC TECHNICAL OFFICER, GRADE 3 (MALE)

(Salary Scale, £440 by £20 to £600)

Candidates should be about 25 and possess a Higher National Certificate in Chemistry, or equivalent qualification.

Full particulars of age, qualifications, experience and positions held, should be sent to

STAFF DEPARTMENT,

NATIONAL COAL BOARD,

CAMBRIAN BUILDINGS,

MOUNT STUART SQUARE, CARDIFF,

by May 29th, 1956.

NORTH THAMES GAS BOARD

CHEMISTS and **PHYSICISTS** holding University Degrees are required in the Laboratories at Watson House, Fulham, S.W.6, to undertake research work on the utilisation and design of domestic and industrial gas and coke appliances, particularly on cookers, water heaters, gas and coke fires, refrigerators, and industrial apparatus.

The Laboratories have recently been modernised and extended and are responsible for research work for the Gas Industry throughout the country.

The appointments will be permanent and pensionable and the starting salary will be within the range of £680-£900 per annum, according to age, qualifications and experience.

Applications should be sent to the

STAFF CONTROLLER,

NORTH THAMES GAS BOARD,

30, KENSINGTON CHURCH STREET, W.8, quoting Reference No. 666/280, to reach him within ten days of the appearance of this advertisement.

BENN BROTHERS LTD. have vacancy for an Advertisement Representative in Birmingham and the Black Country for certain of their Trade Journals. Full-time appointment working from Birmingham Office, so residence in or near that city necessary. Applicants should write in strict confidence, stating age and salary required, with details of career to date, to: The Managing Director, Benn Brothers Ltd., Bouverie House, Fleet Street, London, E.C.4.

PLASTICS DEVELOPMENT ENGINEERS required for expanding Technological Department. Good prospects for men of practical turn of mind with good engineering training. Previous experience of reinforced or thermoplastics desirable. Good pension scheme. Apply giving details and approximate salary required to **PERSONNEL MANAGER, T.I. (GROUP SERVICES) LIMITED, ROCKY LANE, ASTON, BIRMINGHAM, 6.**

SALESMAN for food processing industry, with fundamental knowledge of food chemistry. Salary and good commission. Attractive future prospects. **WRITE BOX No. 802, REYNELL, 44, CHANCERY LANE, W.C.2.**

FOR SALE

FOR SALE—about 1,900 unused Tinplate 56-lb. Cans, 13 in. by 9 in. by 9 in., with 2½ in. press-in lids and folding handles, interiors bright, exteriors slightly rusty. Reduced price to clear. **STEEL DRUMS, LTD., 118, BURDON LANE, SUTTON, SURREY.** Tel.: Vigilant 6506.

HYDRO EXTRACTOR, 26 in. rubber-lined basket, 400/3/50. Pyrex Glass Stills with electric blankets 5-10 and 20 gal. Pyrex 2 in. steam piping. "Pears" 3-throw vertical pump 2,500 gal. at 350 ft. head. 100 gal. and 30 gal. stainless steel jacketed pans. 1 gal. autoclave 1,000 lb. pressure with agitator. "Keebush" 4½ in. Centrifugal Pump 500 gal. per min. at 70 ft. head. Triple Roll Mill Granite Rolls 16 in. by 7 in. Laboratory Granite End Runner Mill. **DARTNALL, 248 HUMBERSTONE ROAD, PLAISTOW, LONDON, E.13.**

600

BROADBENT 48 in. HYDRO EXTRACTOR MONITOR, vulcanite lined. Monitor 55 in. diam. by 20 in. deep with 3½ in. diam. side discharge. Two oval bottom discharge ports 12 in. by 6 in., 3 ports 12 in. by 6 in., 3-point suspension. Motorised 400/3/50.

Unused Self-balancing **HYDRO EXTRACTORS** by Bradford. 26 in. diam. galvanised basket. Fitted spring-operated self-releasing brake, galvanised hinged lid guard. Motorised.

6 Cherry Tree **HYDRO EXTRACTORS**, 30 in. diam. galvanised basket. Motorised 400/3/50. Fitted wire mesh cover with electrical interlock.

Broadbent **HYDRO EXTRACTOR**. Basket 48 in. diam. 3-point suspension. Motorised 400/3/50.

2 Self-balancing **HYDRO EXTRACTORS** by Cherry Tree. 21 in. diam. galvanised basket. Fitted spring-operated, self-releasing brake and hinged safety cover. Motorised.

2 Broadbent **HYDRO EXTRACTORS**. 42 in. diam. basket. 3-point suspension. Fitted Skimmer attachment. Motorised 400/3/50.

GEORGE COHEN SONS & CO., LTD.,
WOOD LANE, LONDON, W.12,
Tel: Shepherds Bush 2070, and
STANNINGLEY, NR. LEEDS.
Tel: Pudsey 2241.

600

COLOUR WORKS PLANT.

For immediate delivery from site.

PEBBLE MILL by Steele & Cowlshaw, 7 ft. by 7 ft. diam. Porcelain lined, driven through spur gearing and vee belts.

Similar Mill to above but Granite lined.

RAYMOND MILL 48 in., 3 roller type by Int'l combustion with cyclone filter and Vibrator.

FILTER PRESS by Johnson, timber plates and frames, 35 Chambers, 43 in. by 29 in. by 1½ in. Washing type. Hydraulic closing gear.

Eight **FILTER PRESSES** by Dehne, plate and frame type, 25 Chambers, 39 in. by 3 ft. by 2½ in.

Two **FILTER PRESSES** by Manlove Alliott. Timber plates and frames, 26 Chambers, 24 in. by 15½ in. by 1½ in. 10 cu. ft. capacity. Washing type, 4 1½ in. connections.

Two **DRYING OVENS** by Mitchell, 4 truck. steam heated with air circulation. 9 ft. 6 in. by 6 ft. by 6 ft.

DRYING OVEN by Mitchell, 2 truck, steam heated with circulation. 9 ft. 6 in. by 3 ft. 6 in. by 6 ft.

ROTARY DRIER by Manlove Alliott, 30 ft. by 4 ft. diam. Coke fired. Rivetted construction.

ROTARY DRIER by Manlove Alliott, 30 ft. by 44 in. Coke fired Welded construction

Two Mild Steel **THICKENERS**, 16 ft. diam., 200 sq. ft., with M.S. supports, covers and hand operated Agitator.

Cast Iron **MIXING TANK**. 7 ft. diam., by 5 ft. deep, sectional, 4 in. bottom outlet. Agitator driven through bevel gears by F. & L. Pulleys.

PORTABLE CONVEYOR by Crone & Taylor, 25 ft. by 18 in. Cleated belt. Pneumatic tyres. D.C. Motor with trailing cable.

GEORGE COHEN SONS & CO., LTD.

WOOD LANE, LONDON, W.12.

Tel: Shepherds Bush 2070, and

STANNINGLEY NR. LEEDS

Tel: Pudsey 2241

FOR SALE

MILD STEEL CHEQUER PLATES

(Unused Stock, RUSTY) ¾" over chequer
8 in. by 4 in., 6 in. by 3 in., 6 in. by 2.5 in.
100 Tons available.

Minimum 2-ton Lots.

MADEN & McKEE, LTD.,
317, PRESCOT ROAD,
LIVERPOOL, 13.

FOR SALE

MILD STEEL ANGLES

Unused Stock, Rusty
1½ in. by 1½ in. by 8 ft.
Large quantity available.
Minimum 2-ton Lots.

MADEN & McKEE, LTD.,
317, PRESCOT ROAD,
LIVERPOOL, 13.

TWO Torrance 6' **EDGE RUNNER MILLS** & one 5' by Cox.

GARDNER MIXER, trough 17' × 8' × 8'

Two **GARDNER SIFTER/MIXERS** size "H" and one "G"

FILTER PRESSES, C.I. and Wood.

Two Scott S.E. **EVAPORATORS** with Pumps & Motors.

MIRACLE MILLS, sizes 1, 2 and 4W.

No. 1 motorised **KEK Mill**, pin disc type.

RICHARD SIZER, LTD., HULL.
Tel. HULL CENTRAL 31743

For Sale—continued

MIXERS—1 Baker Hand-tilted Trough, 16 in. by 24 in. by 20 in. Fast and loose pulleys and clutch. "Z" blades.

1 Ditto Power-tilted Trough, 30 in. by 20 in. by 24 in. Pulley drive and clutch. Four "L" blades.

THOMPSON & SON (MILLWALL), LTD.,
LONDON, E.14.
TEL.: EAST 1844.

PHONE 98 STAINES

MONEL METAL JACKETED PAN—45 in. by 19 in. deep.

STAINLESS STEEL JACKETED MIXERS—39 in. by 32 in. and 40 in. by 24 in.

STAINLESS STEEL PANS—2 ft. 6 in. by 2 ft. 4 in. (Two). 850 and 625 gallon **GLASS-LINED CYLINDRICAL ENCLOSED TANKS.**

(Unused) **PORTABLE STIRRERS**—440/3/50, $\frac{1}{2}$ h.p.

JACKETED CYLINDRICAL OVENS—8 ft. by 5 ft., 7 ft. by 5 ft., 7 ft. 6 in. by 3 ft., 7 ft. by 3 ft., and 6 ft. by 4 ft.

20 & 30 gallon Electrically heated **PANS**, also Welded, Cast-iron and Copper **JACKETED PANS, MIXERS, PUMPS, STILLS, HYDROS, CONDENSERS**, etc.
HARRY H. GARDAM & CO., LTD.

MORTON, SON AND WARD, LIMITED,
STAINLESS STEEL VESSELS

VESSELS of all shapes and sizes, jacketed or unjacketed—with stainless steel mixing gear to requirements; also stainless steel storage tanks and vacuum vessels.

"**MORWARD**" "U"-shaped **TROUGH MIXERS**—up to 2 tons in stainless steel, with agitators, scroll or paddle type, jacketed or unjacketed.

Stainless steel **TROUGHS, TANKS and CYLINDERS** made to requirements.

These items can also be fabricated in mild steel.

JACKETED PANS

100g., 150g., and 200g., new in mild steel, for 100 lb. p.s.i. w.p.—with or without mixing gear.

3 cwt. **TROUGH MIXERS** by **CHALMERS and GARDNER**—stainless steel lined troughs.

50g., 75g. and 100 g. heavy duty **MIXERS** by **FALLOWS and BATES**. Agitators driven through bevel gears from fast and loose pulley.

200g. cast-iron **JACKETED MIXING VESSEL** with nickel-chrome impeller type agitator driven through bevel gears from fast and loose pulley.

BROADBENT HYDRO EXTRACTORS

21" **EQUAL TO NEW**, galvanized baskets, electrically driven through centrifugal clutch or belt driven Safety inter-locks.

PUMPS

Selection of new **MONO** and second-hand **Pumps** in stock—2 in. to 5 in.

Inquiries Invited.

MORTON, SON AND WARD, LIMITED,
WALK MILL,
DOBCROSS, NEAR OLDHAM,
Lancs.

Phone Saddleworth 437

CHARCOAL, ANIMAL AND VEGETABLE horticultural, burning, filtering, disinfecting, medicinal, insulating; also lumps ground and granulated; established 1830; contractors to H.M. Government.—**THOS. HILL-JONES, LTD., "INVICTA" WORKS, BOW COMMON LANE, LONDON, E. TELEGRAMS: "HILL-JONES BOCHURCH LONDON." TELEPHONE: 3285 EAST.**

FOR sale BUELL TURBO TRAY DRYER, steam-heated. Height 21 ft. 8½ in. Overall diameter 18 ft. 4 in. New condition. Will accept low price for quick sale. Can be seen working London area. **BOX NO. C.A. 3468 THE CHEMICAL AGE, 154, FLEET STREET, LONDON, E.C.4.**

WANTED

INDUSTRIAL BY-PRODUCTS, LTD., 16, Philpot Lane, London, E.C.3. will be pleased to receive particulars of any by-products, waste materials and residues for disposal.

WORK WANTED & OFFERED

CRUSHING, GRINDING, MIXING and DRYING for the trade.

THE CRACK PULVERISING MILLS LTD.

Plantation House,
Mincing Lane,
London, E.C.2.

GRINDING, CRUSHING AND GRADING

FINE GRINDING LTD.,

BLACKHOLE MINE, EYAM
TELEPHONE: EYAM 227

PULVERISING of every description of chemical and other materials for the trade with improved mills wharfage, and storage facilities. **THOS. HILL-JONES LTD., "INVICTA" WORKS, BOW COMMON LANE, LONDON, E. TELEGRAMS: "HILL-JONES, BOCHURCH LONDON." TELEPHONE 3285 EAST.**

AMENDMENT OF SPECIFICATION

NOTICE IS HEREBY GIVEN that National Research Development Corporation seeks leave to amend the Complete Specification of Patent No. 728,384 for an invention entitled Anti-Thyroid Compounds.

Particulars of the proposed amendments were set forth in the Official Journal (Patents), No. 3,505, dated April 18th, 1956.

Any person may give Notice of Opposition to the amendment by leaving Patents Form No. 36 at the Patent Office, 25, Southampton Buildings, London, W.C.2, on or before May 18th, 1956.

J. L. GIRLING,

Comptroller-General.

AUCTIONEERS, VALUERS, Etc.

EDWARD RUSHTON, SON AND KENYON
(Established 1855).

Auctioneers, Valuers and Fire Loss Assessors of
CHEMICAL WORKS PLANT AND MACHINERY

York House, 12 York Street, Manchester.

Telephone 1937 (2 lines) Central Manchester.

For Classified Advertising THE CHEMICAL AGE

Gives direct and immediate penetration.
Is the recognised liaison between buyer
and seller.

Accepts advertisements up to first post
on Tuesday for insertion in that week's
issue.

Gives a reduced rate for more than three
insertions and

PULLS IN RESULTS

*The rates are 5d. per word (approx. 7 words
to a line) or 30/- per inch semi-displayed.*

Send your classified advertisements for
Invitations to Tender, Situations Wanted
and Vacant, Articles for Sale, and
Miscellaneous Requirements to:—

THE CHEMICAL AGE

**BOUVERIE HOUSE, FLEET
STREET, LONDON, E.C.4**

Telephone: Fleet Street, 3212 (26 lines)

THE ALUMINA CO. LTD.

MANUFACTURERS OF ALUMINIUM SULPHATE

for PAPER MAKING

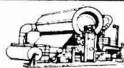

for WATER PURIFICATION



for COLOUR MAKING



for EFFLUENT TREATMENT



for PHARMACEUTICALS



for HORTICULTURE



The above are but a few of the main uses of
ALUMINIUM SULPHATE. We should be pleased to
supply further details on request. Tel: Widnes 2275

IRON BRIDGE WORKS · WIDNES

PCL

PURE CHEMICALS LTD.
PLASTICS DIVISION



SERVICE TO THE VINYL PLASTICS INDUSTRY . . .

FERROCLERE STABILIZERS

Modified soaps, chelating agents and organic syner-
gists now in tonnage production at Kirkby.

STANCLERE STABILIZERS

The largest and cheapest range of organotin stabilizers
in Europe, made by the pioneers.

CLEROXIDE STABILIZERS

A new range of epoxy formulations including a novel
low-viscosity, high-efficiency type.

FERRO PIGMENTS

A stable, light-fast range of inorganic pigments.

TECHNICAL SERVICE

Our new technical service laboratories are fully equi-
ped to serve the needs of the Vinyl Plastics industry.

INDEX to advertisers in this issue

	<i>Page</i>		<i>Page</i>
A.P.V. Co., Ltd. (The)	Front	Lennox Foundry Co., Ltd.	992
Alumina Co., Ltd. (The)	Cover	MacLellan, George & Co., Ltd.	992
	1025	Meigh Castings Ltd.	989
Beryllium & Copper Alloys Ltd.	990	Monsanto Chemicals Ltd.	983
Braby, Fredk. & Co., Ltd.	978	National Enamels Ltd.	Cover ii
British Drug Houses Ltd. (The)	1021	Neckar Water Softener Co., Ltd.	972
Brotherhood, Peter Ltd.	971	Negretti & Zambra Ltd.	977
Bush, W. J. & Co., Ltd.	984	Permutit Co., Ltd. (The)	1019
Callow Rock Lime Co., Ltd. (The)	Cover iii	Prodorite Ltd.	988
Ciech Ltd.	975	Pure Chemicals Ltd.	1025
Classified Advertisements 1022, 1023, 1024 & 1025	Cover iii	Shell Chemical Co., Ltd.	987
Clydesdale Chemical Co., Ltd. (The)	Cover iii	Spencer Chapman & Messel Ltd.	1026
Costain-John Brown Proprietors of Bamag (1953) Ltd.	985	Staveley Iron & Chemical Co., Ltd. (The)	972
Cromil & Piercy Ltd.	Cover iii	Sturge, John & E., Ltd.	981
Cruickshank Ltd.	Cover ii	Taylor Rustless Fittings Co., Ltd.	986
Farnell Carbons Ltd.	988	Todd Bros. (St. Helens), Ltd.	974
Ferris, J. & E., Ltd.	989	Wallach Bros., Ltd.	989
Flexible Ducting Ltd.	973	Ward, Thos., W., Ltd.	982
High Pressure Components Ltd.	976	Whiffen & Sons, Ltd.	979
Imperial Smelting Corporation (Sales), Ltd.	Cover iv	Whitaker, B. & Sons, Ltd.	Cover ii
Kestner Evaporator & Engineering Co., Ltd.	988 & 1020	Worthington-Simpson, Ltd.	980
		Yorkshire Tar Distillers Ltd.	986

ACIDS

Scientifically Prepared
for
TRANSPORT - ANYWHERE.





Oleum
Sulphuric
Battery
Hydrochloric
Nitric
Dipping Acid
&
Distilled Water
*supplied in
any quantity*

SPENCER CHAPMAN & MESSEL, LTD.
45, Park Lane, London, W. 1.
TELEPHONE: GROSVENOR 4311 (4 Lines)

CROMIL & PIERCY LTD.



REGD. CROMIL

GRAPHITE
IN ALL FORMS

MILBURN HOUSE,
"E" FLOOR
NEWCASTLE-ON-TYNE
Tel. : 2-7761

CALLOW ROCK

Gas-Burnt

LIME

for all purposes



QUICKLIME

(Calcium Oxide)

of the highest commercial quality,
in lumps or in coarse powder form

HYDRATED LIME

(Calcium Hydroxide)

in Standard and Superfine grades to
meet most industrial requirements



The Callow Rock Lime Co. Ltd.
CHEDDAR, Somerset

Agents: DURHAM RAW MATERIALS, LTD.,
1-4 Great Tower Street, LONDON, E.C.3.

Decolourising Carbon

ACTIBON

*The most highly
activated of all carbons*

THE CLYDESDALE CHEMICAL CO. LTD.,
142, Queen Street, Glasgow C.1

'Phone : Central 5247/8
'Grams : Cactus, Glasgow

BORON TRIFLUORIDE-ACETIC ACID COMPLEX

Used as a catalyst in polymerisation, alkylation, condensation and other organic reactions.

PHYSICAL PROPERTIES

Specific gravity 1.4
The commercial product containing 40 per cent. boron trifluoride is a pale yellow or brown, rather viscous liquid. It fumes slightly in moist air and is decomposed by water.

On heating, boron trifluoride is evolved until the strength is reduced to 36 per cent. BF_3 corresponding to the compound $\text{BF}_3 \cdot 2\text{CH}_3\text{COOH}$. This then distils unchanged at 140 C. On cooling the 40 per cent. BF_3 complex becomes very viscous below 0 C., but does not freeze even on prolonged standing at -10 C.

BORON TRIFLUORIDE GAS

Used as a catalyst in polymerisation, alkylation, condensation, and other organic reactions.

As a gaseous flux in metal brazing.

CHEMICAL PROPERTIES

The dry gas does not react with metals at room temperatures. It forms a hydrate $\text{BF}_3 \cdot 2\text{H}_2\text{O}$ with water, and readily forms complexes with oxygen-containing organic compounds, e.g. ethers, phenols, alcohols, acids and aldehydes.

PHYSICAL PROPERTIES

The following published data

refer to the pure product:

Boiling point -101 C.
Freezing point -128 C.
Critical temp. -12.25 C.
Critical pressure 49.2 atmos.
Density of gas 3.06 gms./litre at S.T.P.

Commercial gas contains not less than 98.5% BF_3
High Purity Gas contains not less than 99.8% BF_3

CONTAINERS

Steel cylinders of 5-6 lb. or 40-45 lb. net capacity at 1,800 lb./sq. in. pressure.

Advice on materials of construction
and on handling may be obtained from



IMPERIAL SMELTING CORPORATION (SALES) LTD., 37 DOVER STREET LONDON W.1
PIONEERS IN FLUORINE DEVELOPMENT