

30.70 99

THE Chemical Age

VOL. LXXV

14 JULY 1956

No. 1931

SULPHUR

"Daffodil Brand"

DOUBLE REFINED ROLL SULPHUR

99.8/100%

SUBLIMED FLOWERS OF SULPHUR

B.P. and Commercial

POWDERED SULPHUR

All meshes

DISPERSIBLE SULPHUR

WETTABLE SULPHUR

BLACK SULPHUR

GREEN SULPHUR

"ALL GRADES FOR ALL TRADES"

Home Trade & Export

PRICE STUTEFIELD & Co., LTD.

110, FENCHURCH STREET,
LONDON E.C.3.

Phone :
Royal 7011/2

Cables:
Exconsec, Fen, London

WELLS OIL FILTERS

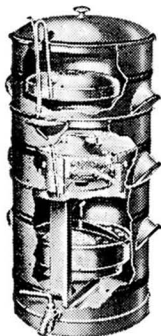

With a Wells' waste oil filter you can use your oil several times over and change it more often. A thoroughly reliable supply of oil is assured with the use of Wells' special filter pads which work in conjunction with Wells' patent syphon feed. The oil delivered from a Wells' filter can be used with complete confidence.

Write for fuller particulars of these filters

Delivery of Oil Filters and special "Wells' Filter Pads from Stock"

Also makers of OIL CABINETS, BARREL POURERS & PORTABLE PARAFFIN HEATER PLANTS

A. C. WELLS & CO. LTD.

HYDE CHESHIRE

Telephone
HYDE 953

Telegrams :
UNBREAKABLE HYDE

CROMIL & PIERCY LTD.



REGD. CROMIL

GRAPHITE
IN ALL FORMS

**MILBURN HOUSE,
"E" FLOOR
NEWCASTLE-ON-TYNE**

Tel. : 2-7761

"Simplicity"

Steam Traps

cannot jam or blow steam. Unique in design, foolproof in operation.

"Simplicity" Steam Traps have only one moving part—a free floating stainless steel sphere.

Each trap is guaranteed. Send for a trap on trial. Write for fully descriptive pamphlet No. STA.

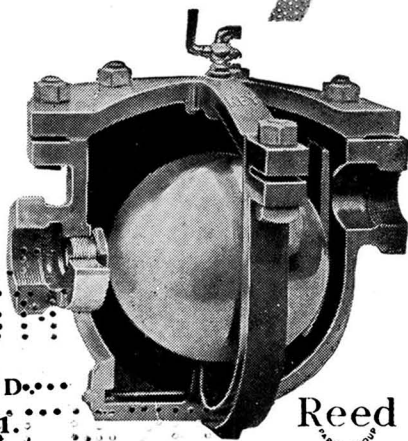

Reed
VALVE GROUP

THE KEY ENGINEERING CO. LTD.

4 Newgate Street, London, E.C.1.

Telephone : City 1185/6/7

and at Trafford Park, Manchester, 17 Telephone : Trafford Park 2056/7



ALL WYNN patent Diaphragm Valves are



STRAIGHT THROUGH

made in

IRON, STAINLESS STEEL,
ALUMINIUM, BRONZE,
REGULUS METAL and
other materials.

lined with

LEAD, RUBBER, NEO-
PRENE, EBONITE, GLASS,
NYLON, P.V.C.,
POLYTHENE, ETC.

Diaphragms

IN VARIOUS GRADES OF RUBBER AND PLASTICS

*For Acids, Oils, Alkalis, Slurries, Viscous Substances, Abrasive
Suspensions, Food products, Beverages, Gases and most
hard to handle fluids.*

WYNN (Valves) LTD

Head Office: 120/2 GRANVILLE ST. BIRMINGHAM 1
Telegrams: WYNVALVE, BIRMINGHAM. Telephone: MIDland 1315-6
Works: BIRMINGHAM AND KIDDERMINSTER

ACTIBON

*... the highly activated
Carbon for ALL
Decolourising purposes*

THE CLYDESDALE CHEMICAL CO. LTD.

142 QUEEN STREET · GLASGOW C.1

Phone: CENTral 5247/8

Grams: "Cactus" Glasgow

CONTINUOUS SUPERPHOSPHATE DEN FROM 3 TO 40 TONS PER HOUR

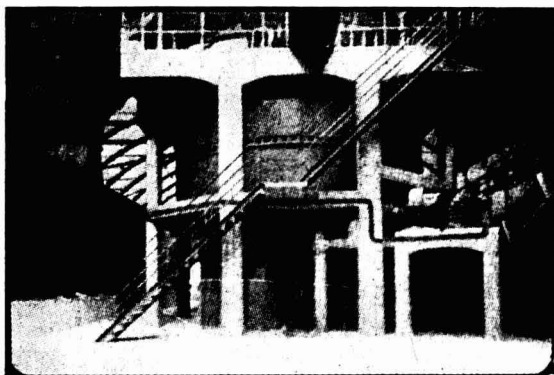

CONTINUOUS DEN: Output 25 tons/hour

SULPHURIC ACID PLANTS

PYRITES & SULPHUR
BURNERS

DUST PRECIPITATORS

GRINDING MILLS

SUNDRY CHEMICAL PLANTS

Phone: FROBISHER 0769

Grams: MORICHEMIC, LONDON

MORITZ
CHEMICAL ENGINEERING CO. LTD.
204, Earls Court Road London, S.W.5

Ammonia water
 Anhydrous
 liquid ammonia
 Anthracene 40%
 Benzol/benzene
 Caprolactam
 Creosote oil
 Cyclohexanol
 Cyclohexanone
 Ethyl ether
 Naphthalene 78° C
 Nitric acid
 Phthalic anhydride
 α Picoline, techn. pure
 Potassium ferrocyanide
 Pyridine bases
 Pyridine pure
 Spent oxyde
 Toluol/toluene
 Urea

**Sales office of 8 leading
 Dutch Chemical Industries**

Export • Import • Transit

**Nederlandsch
 Verkoopkantoor
 voor Chemische
 Producten N.V.**

63 Mauritskade - Amsterdam - Holland
 Postbox 4038 - Telephone 54322
 Telegrams: Chemicals - Telex 12270

V.4.40E

LONDON OFFICE:

GREYER, BRECHEISEN & CO., LTD.

BUSH LANE HOUSE, CANNON STREET, LONDON, E.C.4.



duomeens

where R is a fatty acid radical

With a secondary *and* a primary amine group in a single molecule Duomeens exhibit stronger polarity and greater cationic activity than the corresponding simple amines. They are more strongly absorbed to metals, fibres, plastics, masonry and other materials.

They are also steppingstones in the synthesis of complex compounds: Duomeens are used in the curing of epoxy type resins; they can be quaternarized to give double quaternary salts. Their water soluble salt

are flotation collectors, corrosion inhibitors (applied from aqueous solution) or emulsifiers.

For general information ask for booklet on Duomeens. The following Technical Bulletins are also available: C-2/2 on road making, C-3/L on use in epoxy type resins, G-2 on eliminating static electricity from fibres and L-4 and L-8 on using Duomeen T dioleate in paints. Also Market Development Memo. No. 2 on a nonionic double tertiary amine. Duomeen T (diamine of tallow fatty acids) and other Duomeens are now freely available in this country.



ARMOUR & COMPANY LIMITED

CHEMICAL DIVISION, LINDSEY ST., LONDON, E.C.1
CL Erkenwell 9011



Full loads of livestock, perishables, or household
removals can go "GREEN ARROW"
Any full load for Export can go "GREEN ARROW"
—quicker, safer, registered all the way to
U.K. destination or dockside for only 2/6d.



"GREEN ARROW" TO BE SURE

ASK YOUR LOCAL GOODS AGENT FOR DETAILS

BRITISH RAILWAYS

**YORKSHIRE
MINED**

BARYTES

BARIUM SULPHATE 98-99%

**HIGH GRADE
QUALITIES**

FLUORSPAR

**ACID
GRADE**

CALCIUM FLUORIDE 98-99%

PRICES
AND SAMPLES
ON APPLICATION

Produced by:—
DALES CHEMICALS LTD
GRASSINGTON, YORKS

SOLE SELLING AGENTS

COLE & WILSON LTD

24 GREENHEAD ROAD, HUDDERSFIELD
Telephone HUDDERSFIELD 1993
WORKS—Common Road Bay Hall Birkby Huddersfield
Telegrams COLOUR HUDD.
Telephone Huddersfield 2499

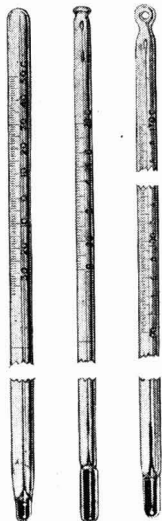

ZECOL
REG. TRADE MARK

THERMOMETERS



CHEMICAL THERMOMETERS



HYDROMETERS



PHONE :
LIBERTY
2283-6

G. H. ZEAL LTD.

GRAMS :
ZEALDOM
SOUPHONE
LONDON

LOMBARD RD., MORDEN RD., MERTON, LONDON, S.W.19.

'SPECTROSOL'

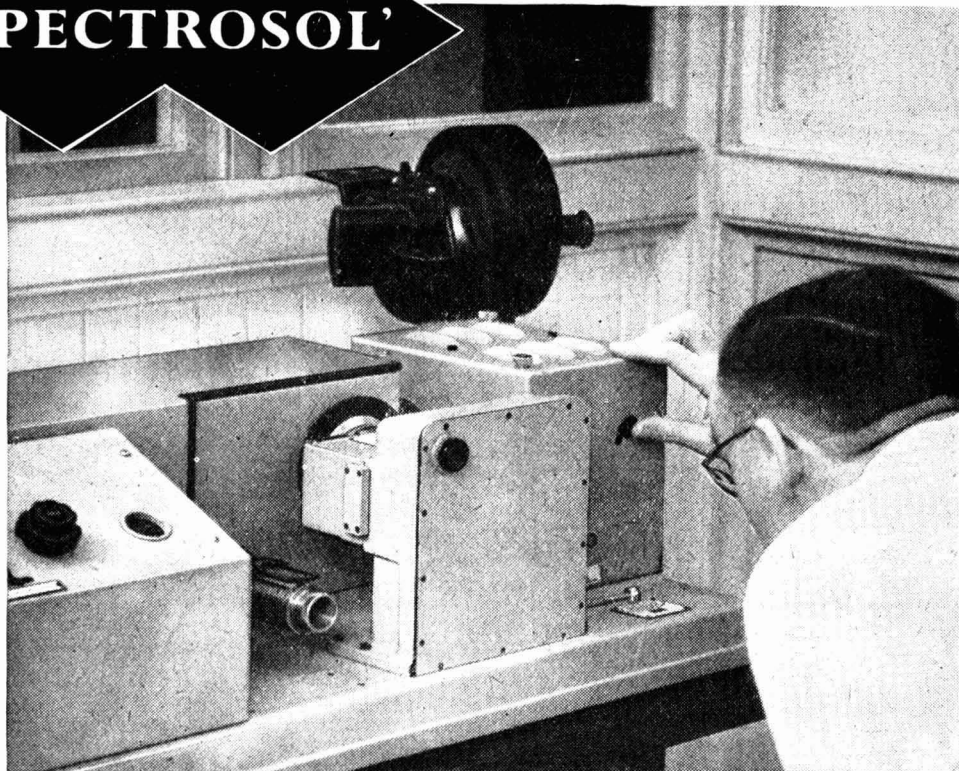

"Spectrosol" Solvents in use in the Analytical Laboratories of Parke Davis & Co.

Since the introduction by Hopkin & Williams Limited of "Spectrosol" Solvents, specially purified for absorption spectroscopy, the range has been extended and now comprises the following items:—



Code No.

2858.5 Carbon Tetrachloride
3073 Chloroform
3566.3 Cyclohexane
4101 Ethyl Acetate



Code No.

4118.5 Ethyl alcohol
4554.5 *n*-Hexane
6346.5 *iso*-Octane
7218.5 *iso*-Propyl alcohol

"Spectrosol" Solvents are supplied only by Hopkin & Williams Limited and a descriptive leaflet and price list will be sent free on request.



HOPKIN & WILLIAMS Limited

Fine Chemicals for Research and Analysis

CHADWELL HEATH, ESSEX, ENGLAND

TANTIRON

*pipes, vessels & fittings
for handling Corrosives*

Tantiron, the registered trade name applied to Silicon iron castings, was first cast and produced on a commercial scale by The Lennox Foundry Co. before 1910, so we are well justified in our claim that it is the first—and still the best—high silicon resisting iron.

Tantiron is manufactured into Pumps, Valves, Dephlegmators, Pipes, Cocks, Absorption Towers, Pans, Reaction Vessels, Coolers, etc.

Tantiron resists most of the known persistent corrosive agents. Tantiron Pipes, Valves and Fittings are subject to a hydraulic test before despatch and test certificates furnished when requested.

S I L I C O N I R O N



LENNOX FOUNDRY CO., LTD.,
Tantiron Foundry, Glenville Grove, London, S.E.8.

EXCEPTIONAL OFFER!

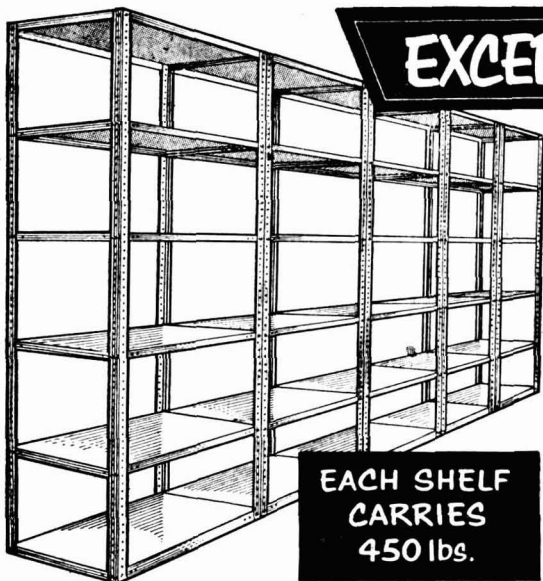

UNBEATABLE VALUE IN INDUSTRIAL STEEL RACKS

Here is a genuine opportunity to equip your premises with new **Heavy Duty Racks** at less than Office Shelving prices by buying direct from manufacturer. All usual types and sizes. Sample rack on request.

Full details from Manufacturer :

ROCO PRODUCTS LTD., 3 ORANGE STREET, BRISTOL 2. Telephone : 27620 PBX

**Nickel Oxides and Salts
Cobalt Oxides and Salts
Selenium and Tellurium**

For information, please write



THE MOND NICKEL COMPANY LTD.
THAMES HOUSE · MILLBANK · LONDON · SW1

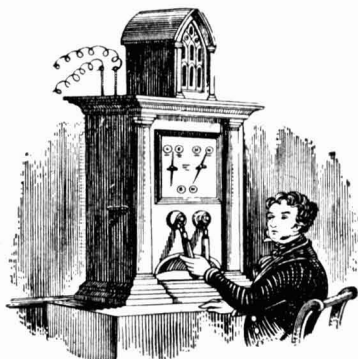

The span of a century has seen the development from the first telegraph to modern radar equipment. In this period also The Morgan Crucible Company has grown to a unique position; a position in which the products, parts and pieces they develop and manufacture are essential, either directly or indirectly, to every industry throughout the world. Their products may have helped the early engineers, certainly today's electronics industry recognises the value of their aid—and the future will not ask in vain from the technologists and craftsmen who will use the knowledge and skill accumulated in these past 100 years.

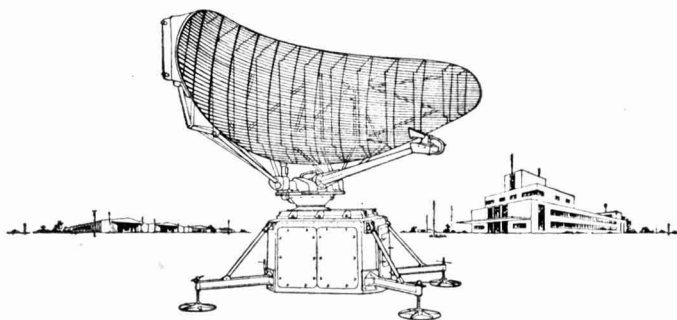
**CENTENARY****1856-1956**

carbon and graphite—electrical, chemical and mechanical; crucibles, furnaces, refractories; radio parts, and sintered metal products.

THE MORGAN CRUCIBLE COMPANY LTD.,
BATTERSEA CHURCH ROAD, LONDON, S.W.11 Telephone: BATTERSEA 8822

Volume LXXV
Number 1931

The Chemical Age

Established 1919

The Weekly Journal of Chemical Engineering and Industrial Chemistry

BOUVERIE HOUSE · 154 FLEET STREET · LONDON EC4

Telephone : FLEET STREET 3212 (26 lines) Telegrams ALLANGAS · FLEET · LONDON

CONTENTS · 14 JULY 1956

SCI Celebrates 75th Anniversary	63
Guildhall Reception for SCI	64
Note & Comment	65
Big Biochemical Factory in Italy	66
News Briefs	67
Polyurethane Resins	69
Explosives by Automation	72
From all Quarters	75
Colonial Progress in Research	76
People in the News	77
German Atomic Research	79
Legal Studies—Importing a Patent	81
Safety Notebook	83
Market Reports	85
Publications & Announcements	86
The Chemist's Bookshelf	87
Parliamentary Topics	89
Commercial Intelligence	90

Editor : Geoffrey F. D. Pratt

Manager : H. A. Willmott

Director : N. B. Livingstone Wallace

MIDLANDS OFFICE :
Daimler House, Paradise
Street, Birmingham

Phone : Midland 0784/5

SCOTTISH OFFICE :
116, Hope Street,
Glasgow, C.2

Phone : Central 3954/5

LEEDS OFFICE :
Martins Bank Chambers
Park Row, Leeds, 1

Phone : Leeds 22601

SINGLE COPY 1/3 (BY POST 1/6)

ANNUAL SUBSCRIPTION 52/6



JMS

FILLERS, PIGMENTS AND BLEACHING AGENTS

Write Dept. B/27 for further details



J.M. STEEL & CO. LTD.

35/38, KINGSWAY LONDON W.C.2 Tel. HOLborn 2532/5

BRANCH OFFICES

51, SOUTH KING ST. MANCHESTER 2 Tel. Deansgate 6077/9

45, NEWHALL ST. BIRMINGHAM 3 Tel. Central 6342/3

HEAT TRANSFER

to corrosive liquids

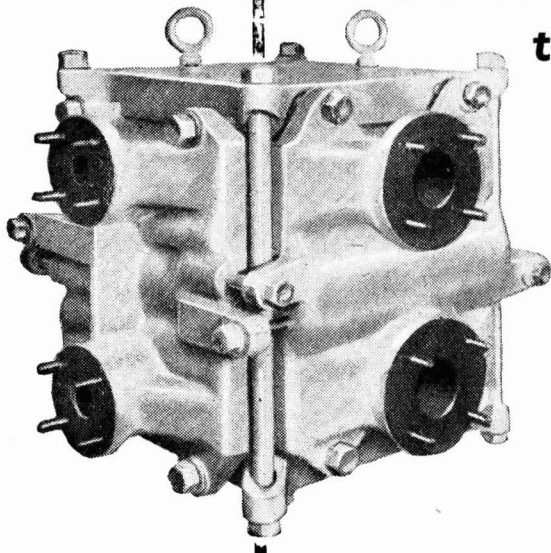

In the heating and cooling of highly corrosive liquors, carbon and graphite provide ideal materials of construction. For successful application of these materials however, specialised design is essential. The GRAPHITE CUBIC HEAT EXCHANGER is an outstanding example of successful design and provides a unit of exceptional performance for all heat transfer operations which is, at the same time, robust, compact and easy to maintain.

POWELL DUFFRYN CARBON PRODUCTS LTD

Springfield Road, Hayes, Middlesex. Telephone: Hayes 3994-8

Queer Economy

A MODERN gambit in seeking publicity is to write a letter and send it not to one newspaper but to a large number of newspapers. Organizations seeking public support or having some special viewpoint to air often adopt this course. However, it is not usually adopted by an individual. Generally, the man or woman with some enthusiastically held opinion is content at any one time to send a single letter to one suitable paper. In recent weeks, however, a letter with a pronounced anti-chemical theme has appeared in several British newspapers, though there is no suggestion or implication that the views expressed are those of an organization. It has to be assumed, therefore, that the various press appearances of this letter, though suggesting organized distribution, are due to personal faith and are not, even indirectly, attributable to some particular anti-chemical organization.

The letter suggests that it would be a better economy to save the fertilizer subsidy's cost than to cut the subsidy on milk and remove the subsidy on bread. The writer claims to have visited farms of up to 700 acres in size where no chemical fertilizers are used and where better crops are grown than those produced by farmers who scorn the organic or 'muck and magic' methods. By deleting the fertilizer subsidy from internal national accounts and by improving the balance of trade position through not having to import fertilizer raw materials, we should all, as taxpayers be better off. The mass of evidence that points in an entirely opposite direction fills many shelves of books; and practically every man of repute in agriculture, or agricultural science, regards fertilizers as one

of the primary tools of productivity and good economy. The results of over 110 years of research at Rothamsted, to say nothing of research at scores of other centres here and in a variety of other countries, are ignored.

Fertilizer subsidies (which, incidentally, are paid to farmers after fertilizers have been purchased) are said merely to help the already prosperous chemical industry to sell its products more cheaply. In fact, of course, these subsidies are intended to encourage farmers to raise productivity and so reduce their costs of production, and of the various subsidies still in existence it is doubtful whether any other has so much support from all parties in the House of Commons. The subsidy *in toto* should be looked upon as a production grant. There is abundant evidence that suitable fertilizers will increase crop yields by at least 20 or 25 per cent, yet their cost will add only seven or 10 per cent to the basic costs of cropping; often the results are far more attractive—for example, when one or another plant-food deficiency in a soil makes it imperative for fertilizers to be used in order to produce any yield that is economic. For most crops the highest average yields in world farming are regularly obtained by Dutch farmers, and Dutch farmers have for years been the highest users of fertilizers per acre. The need to use fertilizers regularly in farming, and indeed to use much more fertilizer on most farms and in all countries, is constantly being stressed by world organizations like FAO and OEEC. It is not the isolated view of scientists in one country or even in a few countries; it is not a view that is the subtle product of commercialism. However, the readers of

several reputable newspapers have now been told that fertilizers are unnecessary, that better crop yields can be obtained without them, that nitrogen can be obtained by growing leguminous crops, and other minerals by growing deep-rooted leys.

It is true that leguminous crops (those whose root systems act as hosts to nitrogen-fixing bacteria—clovers, peas, beans, lucerne) 'make' their own nitrogen and their residues will add nitrogen to the soil. This method of securing nitrogen has been widely employed in British grassland farming for many generations. It is more totally used in New Zealand where the shorter period of cold and wet weather gives clovers an earlier and longer grazing season. It is much less certain that leys composed of deep-rooted herbage species will lift sufficient phosphate and potash from sub-soils to top-soils. However, let it be assumed that on a majority of farms this could in fact be accomplished and let it be forgotten that many sub-soils, like top-soils, are sadly low in their contents of available phosphate. Let even the long-established farming knowledge that phosphates bring clovers be dismissed. If all the nitrogen needs of cropping must be secured by growing leguminous crops in rotation, and if all top-soils must slowly build up their phosphate and potash contents by growing (also in rotation) deep-rooted leys, then every farm must become either a mixed farm or a farm producing dairy and meat products exclusively.

Most of the benefits of mechanization would depart from arable farm economy, for on few farms can mechanization be provided for a wide variety of operations; mechanization has largely expanded because use of fertilizers has limited the need for rotations and cropping has become specialized. Today the lowest production costs for wheat are on large farms which grow cereal crops year after year and where fertilizers are regularly and often heavily used. This land is occasionally rested but, on the whole, its output is fairly described as continuous rather than rotational. This modern type of farming, despite its established efficiency, would be discarded. Instead of lorries bringing spring fertilizer dressings,

instead of drills applying these on hundreds of acres in a few days each year, the land involved would have to produce leguminous crops and deep-rooted leys to feed animals which such farms do not now possess.

The national balance of payments would not then be disturbed by a relatively small expenditure per annum on raw materials for fertilizers. Instead, much more grain would have to be imported than is imported now, both for feeding people and for feeding cattle in the winter. The fact that grain is often a dollar-area import, whereas raw phosphate and potash are soft currency imports is apparently a trivial and irrelevant consideration. But would a farming system dominated by rotational legumes and leys produce more milk and meat? Even if we assume that almost all modern agricultural soil research results are 'phoney' and that, in fact, high yields could be obtained on all soils without fertilizers, we still must face the fact that the present output of milk is nearly saturating the home market, that home meat production is always awkwardly seasonal.

Nevertheless, a 200-words letter, stating no specific or measured evidence and ignoring these economic consequences, advocates abandoning the fertilizer subsidies and introducing instead the 'unsubsidized skill' of 'modern organic farming'. Canute who thought the tide would respect monarchy and Kipling's flat-earth voting village had better arguments. With more than 50 million mouths to feed and a good deal less than two acres of agricultural land per head to use, the most critical item in our imports/exports accounts is the bill for imported food. To hold this within practical range we need high output per acre at home, and reasonable costs per hundredweight or ton or gallon of produce. Full efficiency in these directions has yet to be reached, but it has so far been approached only in the period of expanded fertilizer use. It is surely irresponsible to advocate a return to farming methods which failed economically when we had a much smaller population to feed and virtually no balance-of-payments problems.

SCI's 75th Anniversary

Reception Opens Annual Meeting

AT THE annual general meeting of the Society of Chemical Industry at the Royal Institution, London W1, on Tuesday morning (10 July) Mr. Julian M. Leonard was re-appointed president for 1956-7. Dr. H. Levinstein, Sir Eric Rideal and Sir William Ogg were appointed past presidents, to serve on the council, and Mr. G. O. Curme and Professor H. D. Kay were appointed vice-presidents for the term 1956-59.

Delegates from the following learned societies then presented scrolls containing congratulatory addresses to mark the Society's 75th anniversary:—The Royal Society, The Australian Academy of Sciences, The Royal Academy of Belgium, The Chemical Society of Belgium, The Flemish Chemical Society, The Chemical Institute of Canada, The Royal Danish Academy of Science, The Danish Academy of Technical Sciences, The Danish Chemical Society, The Danish Society of Civil Engineers, The Chemical Society of France, The Society of Industrial Chemistry, Paris, The National Association of Industrial Chemistry, The Royal Netherlands Chemical Society, The New Zealand Institute of Chemistry, The Norwegian Chemical Society, The Royal Spanish Society of Physics & Chemistry, The Royal Swedish Academy of Engineering Science.

Representatives from the following UK bodies also presented scrolls:—The Royal Institution, The Royal Society of Arts, The Chemical Society, The Royal Institute of Chemistry, The Institution of Chemical Engineers, The Society for Analytical Chemistry, The Faraday Society, The Institute of Fuel, The Geological Society, The Iron & Steel Institute, The Institute of Metals, The Institute of Petroleum, The Physical Society, The Institute of Physics, The Royal Photographic Society, The Royal Society for the Promotion of Health, The Institution of Sewage Purification, The Institution of Gas Engineers, The Institution of Public Health Engineers, The Institution of Water Engineers.

Delegates from the following American bodies also presented addresses:—The American Chemical Society, The American Institute of Chemistry, The American Institute of Chemical Engineers, The Chemists Club, and the Electrochemical Society. A letter of congratulations was also received from the Chinese Chemical Society

Sir Charles and Lady Dodds with Alderman Sir George Wilkinson and Lady Wilkinson, receiving Sir William Ogg (left) immediate past-president of the Society, and Professor M. Lora-Tamayo from the Royal Spanish Society of Physics and Chemistry, Madrid (right). Sir George Wilkinson is Lord Mayor of London 'locum tenens'; Sir Charles is London section chairman



GUILDHALL RECEPTION FOR SCI



At the SCI reception in Guildhall on Monday evening: 1 President Julian M. Leonard with Mrs. Leonard and Mr. and Mrs. G. Maynard Jenkins of Kansas City, US; 2 Dr. L. A. Jordan explains a technical point to Mr. and Mrs. C. S. Garland and Mr. E. F. Parker; 3 Mr. and Mrs. T. H. Gant; 4 Mr. and Mrs. E. D. Catton discuss the week's events with Mr. and Mrs. G. King; 5 Mr. C. D. Collins (left) talks to Mrs. G.

Finlayson. Mrs. Collins and Mr. Finlayson (right) listen with interest; the Finlaysons are from West Africa; 6 Dr. and Mrs. J. A. Cranston go over the programme with Miss H. Cranston. Following the reception refreshments were served in Guildhall and in the ancient crypt while a string ensemble of the Guildhall School of Music and Drama, conducted by Michael Steyn, played in the musician's gallery

NOTE & COMMENT

MORE CHEMICAL WORK than might be expected is described in DSIR *Forest Products Research Board Report 1955* (HMSO, 4s 6d). Some of this concerns the constituents of specific woods, the hemicellulose of beech, the oligosaccharides of pine, pigments in East African Mulberry, etc.; however, investigations of this kind are more suitably studied in detail by specialists than briefly discussed here. As might be assumed, paper chromatographic methods of analysis are being considerably employed. The consuming world today becomes more and more sensitive about corrosion, and the Forest Products Research Laboratory increasingly receives inquiries about the corrosion of metals in the presence of wood. Problems arise in wood/aluminium assemblies, and radio set makers have had trouble with cadmium-plated parts set in birch plywood cabinets, trouble that does not similarly occur in plastics-made cabinets. Acetic or other acids in woods seem to be the corrosive agents in this latter problem, which is, incidentally, mainly experienced in the tropical conditions which tend to increase acidity development in wood. An occasional cause of metal corrosion in contact with wood is a high content of ordinary salt in the wood. Metal parts in a piano, nickel-plated parts of coffin-handles, steel cables on wooden drums, a saw-blade in a wooden handle, are all cases of unusual corrosion experienced in recent years. Yet in all of them the wood was dry and conditions should not have been corrosion-favourable. In each the trouble was traced to an unexpectedly high sodium chloride content, and this just as surprisingly varied in different portions of the wood; for example, one end of a maple rail had a salt content of 1.4 per cent and the other a content of 4.0 per cent. This is now believed to be due to the common practice of floating logs in

salt water when they are transported as lumber; logs that are partially submerged will build up high salt contents in their upper parts through evaporation from the exposed surfaces. The corrosion of wood itself has also required study. A case of timber stored in a yard in an industrial town in Lancashire has shown that acidic fumes can be undesirably adsorbed from the atmosphere, and the question whether timber should be stored for long periods without protection in industrial centres may represent a new subject for investigation. The Laboratory dealt with 194 chemical inquiries during the year and also gave chemical advice on wood problems to 44 visitors. Many of the inquiries concerned the selection of wood and pre-treatment of wood for use in resisting chemical attack in vats, filter-presses, pickling tanks, plating baths and so on. Clearly wood as a corrosion-resisting material in chemical processes is not a neglected old-timer, even in these days of alloys and synthetic materials.

Breaking Tradition

EVERY PUBLIC COMPANY presents its annual report to shareholders, and in recent years some companies have broken away from the tradition of sombre brevity, giving results instead in attractively presented manner, often graphically. This is all to the good, but even at best it reports in one direction only. Imperial Chemical Industries, however, presents a report on the achievements of 1955 to its own staff in what is frankly called 'an illustrated digest of the company's annual report for 1955 produced specially for ICI men and women,' words with a pleasing straight-from-the-shoulder ring. It is certainly a digest that will prove digestible. A boldly presented tabulation—'What we earned and where it went'—shows that of every £ earned, raw materials, etc., consumed 11s 8d; wages, salaries, and pension benefits, 4s 7½d; the employees' profit-sharing bonus, 1½d; depreciation, 1s; taxation, 1s 2d; reserves, 11d; and net dividends, 6d. That dividends absorb 6d in the £ hardly strikes a note that is irrelevant in these days of vexed economic arguments. However, we would certainly make one

criticism, and that is to suggest that expenditure on reserves should not, even in this simplified breakdown, swamp the figure for expenditure on research and development; for, using information given on this topic on a later page, out of the 11d in the £ devoted to reserves, roughly 5d went to research and development costs.

Anti-Humbug

ALL COMPANIES, even relatively small ones, might do well to consider producing some similar digest of annual trading results for their employees. Annual reports to shareholders, save in the cases of private companies, are not secret, but badly-informed criticism can result from the specialized style of presentation usually adopted. Worse still, shortened versions in newspapers may often be the only source of information seen by employees, and judgment is not always fair when no more than a part of the picture is seen. No one can afford to forget that this is an age of paradise for the political humbug. The worker's desire for a rising standard of living has never been stronger and this has to be expressed against all the strains of rising living costs. Even the most conscientious and rationally-minded man has times during each year when his economic skin has an irritated sensitivity. There is no shortage of humbugs both in and outside politics to exploit these circumstances. Few large organizations have a better record than ICI for labour and management relationships, and they might well have been complacent; instead, this attractive but factual account of the year's trading has been given. It is a thoughtful and stimulating example.

Sweden's Oil Safeguarded

A new State-owned company, A/B Oljetransit, is to be formed in Stockholm to construct an oil port on the Trondheimsfjord in Norway to facilitate oil transport from this ice-free fjord direct to Sweden. The oil will be stored inside the mountains. The installation is designed in the first instance to safeguard Sweden's demand for oil in case of war or blockade, but can under certain circumstances also be run as a commercial undertaking.

Big Biochemical Factory

Pfizer Project in Italy

DURING a press-conference recently held in Rome, Mr. John E. McKeen, president, confirmed that the Pfizer Company had decided to build a big biochemical factory in Latina, near Rome. On 5 June a ceremony took place during which a sample of soil was taken for shipment to the Pfizer laboratories in New York in order to examine the possibility of obtaining from it a new antibiotic, useful for the treatment of infections and diseases. In case of favourable results, the new product will be called Latinamycin.

The Pfizer president said that the Latina zone had been selected in order to contribute to the development of the Italian depressed areas and also because it was convenient for the realization of the productive and commercial programmes prepared by this company. The factory should go into operation during the spring of 1957. The organization was in the hands of Italian specialists, and a large part of the necessary machinery and equipment would be built in Italy. The new plants, to be manned by Italian personnel, would prepare pharmaceutical, veterinary and agricultural products intended for the internal market and eventually for export.

No Competition

Mr. McKeen stated that his company did not intend to compete with Italian firms, since the products to be put on the market were not produced in that country.

Underlining the importance of laboratory analysis on soil samples, Mr. McKeen mentioned the valuable contribution given by the discovery of the Pfizer Terramycin antibiotic that has proved its effectiveness against numerous micro-organisms such as the *streptococcus*, *staphylococcus*, *pneumococcus*, gram-negative types of the *coli* group, *salmonella* and other bacilli. Terramycin has been of great usefulness in the treatment of about one hundred types of infections including pneumonia, dysentery, urinary infections, peritonitis and other surgical infections.

The technicians have successively ascertained that the product, added to the aliments for domestic animals, besides exerting specific therapeutic and prophylactic actions, accelerates considerably the growth of subjects and reduces their mortality.

NEWS BRIEFS

Revised Part of BS

Following the recent issue of a number of revised parts of BS 903 'Methods of testing vulcanized rubber', the British Standards Institution has now published Part C3 'Permittivity and power factor of insulating soft vulcanized rubber and ebonite' which is the first part which relates to electrical tests. The document does not differ greatly from the 1950 version except in the layout and in the adoption of metric dimensions. Copies of this new part are available from the British Standards Institution, Sales Branch, 2 Park Street, London W1, price 2s 6d.

Deaths Total Three

Three people have now died as a result of the explosion on Tuesday 3 July at the factory of Explosives & Chemical Products Ltd, near Harwich (see *THE CHEMICAL AGE*, 1956, 75, 38). The latest death was that of Sisin Bhusan Gupta, aged 33, a student worker from Calcutta.

Extension Plans Prepared

Plans have been prepared by the South Yorkshire Chemical Works Ltd. for an extension to their premises in Mangham Road, Rotherham, Yorks.

Fortnight Closing Arrangements

The Adderley Street premises of United Wire Works (Birmingham) Ltd., will be closed from 5.0 p.m. on Friday, 27 July until 7.30 a.m. on Monday, 13 August. During this period, no goods will be despatched or received.

Textile Machinery Course

The opening session of a new course organized by the Textile Institute took place on Thursday 5 July in Manchester. The title of the course is 'New Developments in Testing Machinery' and it has been arranged in co-operation with Textile Machinery Makers Ltd. Most of the lectures will take place at the firm's Hartford works, Oldham.

New Science Courses

A special series of courses for teachers in schools and technical colleges is being held at Sunderland Technical College for instruction in semi-micro preparative and analytical techniques. These courses are being organized by Mr. L. H. W. Hallett (principal of chemistry department) and Dr. J. H. Wilkinson, senior lecturer at Sunderland and author of the work *Semi-Micro Organic*

Preparations. Students participating in the series will draw their apparatus entirely from the standard range of semi-micro glassware manufactured to Dr. Wilkinson's designs at the works of James A. Jobling & Co. Ltd. of Sunderland, Makers of the Pyrex range of laboratory and scientific glassware.

Telephone Number Changed

With effect from 7 July 1956, the telephone number of Aero Research Limited, Duxford, Cambridge, has been changed to Sawston 2121. The telex number is 10-101.

Odour-Control Chemicals

May & Baker Ltd. announces the introduction of the Alamask range of odour-control chemicals for use in industry.

These are designed for the purpose of masking unpleasant industrial odours. They were first developed by E.I. Du Pont de Nemours & Co. and subsequently by Rhodia Inc. in the US, where they are now in use.

Arrangements have been made for the manufacture of the Alamask series of products at Dagenham, and for their sale by the May & Baker group of companies throughout the British Commonwealth and Empire, with the exception of Canada.

Brick Making Lubricant

Chairman and managing director of Savotex Industries Ltd., Maraisburg, South Africa, Mr. J. BERMAN, is expected in this country shortly. He will be the guest of Jacobson van den Berg (UK) Ltd., whose South African branch act as factory export agents for Savotex Dylube which is used in the ceramic industry as a lubricant replacement in the dies of automatic and semi-automatic extruding units, and as an additive to clays.

ABCM Changes

The Association of British Chemical Manufacturers is to have a new director and secretary, and the association has advertised for a successor to the present director, Mr. J Davidson Pratt. Enquiry by *THE CHEMICAL AGE* brought the statement from Mr. Davidson Pratt that he would be retiring next year.

Titanium Mill Contract

Contract for the erection of the titanium fabrication mill at Waunarlwyd, South Wales, has been awarded by ICI Ltd. to H. K. Ferguson Co. of Great Britain Ltd., a subsidiary of H. K. Ferguson Co. of the US. The mill is due to be completed by the end of 1957. It will consist of two large buildings to house the rolling processes, together with auxiliary facilities.

New Impetus to Fuel Efficiency

NIFES Progress Survey

BRITAIN is spending about £30-£35 million a year on heating extra and quite useless air, said Dr. Angus Macfarlane, chief executive of the National Industrial Fuel Efficiency Service, last week. He added that in theory 10 tons of air was needed to burn one ton of coal but a practical figure was 15 tons. The average air consumption throughout industry was probably 22 tons. Thus precious fuel was used simply to create hot air which did no work at all and went out of the chimney at three times the temperature of boiling water.

Commenting on the second progress survey of NIFES, Dr. Macfarlane said that it gave examples of many ways in which industry was benefiting from the knowledge that the Service was making available.

The report says that during the year three factors have given a new impetus to fuel efficiency. First there was a substantial increase of coal prices in July 1955 which was quickly reflected in the charges for gas and electricity. Second, there was the need to increase the importation of coal to nearly 12 million tons for the year and so further aggravate the country's already adverse balance of payments. Third, the public concern resulting from this situation led several authorities to examine Britain's longer term need for energy. The Minister of Fuel and Power stated in February 1956 that by 1965 the country's requirements might exceed 300 million tons of coal or its equivalent in other fuels, and that of this total 22 per cent would have to be imported from abroad.

The report points out that when Mr. Harold Macmillan announced the special investment allowance for fuel efficiency equipment in his Budget, he described it as sharing with shipping and scientific research 'an absolute priority'.

From surveys carried out during the year it is estimated that 12.4 per cent of total fuel consumption could be saved in the chemical industry. The report adds that follow-up action on earlier surveys gives confidence that survey estimates are conservative and are quite often exceeded in practice.

The average capital investment required to save one ton of coal a year is, according to the report, about £13.8.

Support for Research Urged

SPEAKING in London on 5 July, Professor A. C. Frazer, head of the Department of Biochemistry and Pharmacology, Birmingham University, stressed the importance of food manufacturers giving the fullest support to food research in all its aspects. Professor Frazer was speaking on his election as president of the British Food Manufacturing Industries Research Association.

One of the major objectives of food research, said Professor Frazer, was the conservation and improvement of food supplies. This applied not only in this country but all over the world. Better crops, livestock, yields, keeping qualities, storage and distribution were needed if everyone were to have, and to go on having, an adequate diet.

The work of BFMIRA was not only important to the manufacturer and food scientists. It was important to everyone. The industry must build up a body of knowledge that would enable it to give proper assurances to the consumer that the procedures used in food technology were harmless, Professor Frazer added.

Nitrate of Soda Prices

UNTIL further notice, announces the Nitrate Corporation of Chile Ltd., the prices for Chilean granulated nitrate of soda, 16 per cent nitrogen, in lots of not less than six tons delivered carriage paid to any railway station in Great Britain or c.i.f. main ports in the Isle of Man, are as follows:—

July	£27 0s
August/September	£27 5s
October/November	£27 10s
December/February	£27 15s
March/June	£28 0s

These prices are per ton of 2,240 lb. gross weight.

Smaller lots delivered carriage paid are subject to the following surcharges:—

4 tons and over, but less than 6 tons	5s per ton
2 tons 4 tons	10s
1 ton 2 tons	20s
5 cwt. 1 ton	1s 6d per cwt.
Less than 5 cwt.	2s 6d

These surcharges do not apply to any quantity collected from the company's nitrate depots, but there is an allowance of 15s per ton when lots of 5 cwt. and over are collected. These prices are subject to alteration or withdrawal without notice.

Development Since 1950

by E. G. Curphey

Polyurethane Resins

SINCE 1950 the development and applications of the polyurethanes have been such that their industrial potential, particularly as foams, must be regarded as a serious challenge to other manufactured plastics at present available. Their uses range from the manufacture of household sponges, bath mats, and neck rests to the production of cellular web for winter fabrics and the making of plies and treads for tyres.

Polyurethanes displaying low temperature characteristics and possessing particularly good flexibility in the region of -80°F have been obtained by the polycondensation of an arylene di-*isocyanate* and a polyalkylene oxide ethylene glycol, the latter preferably having molecular weights ranging from 750 to 10,000. Elastomers having good tear resistances and brittle points in the region of -62°F have been prepared by milling for two hours at 70° to 75°C , in a Werner Pflleiderer mill, the ether and excess of tolylene di-*isocyanate*.

Reactions Retarded

When other aliphatic reactants like the aliphatic amines are used, these glycol-*isocyanate* reactions are retarded by the presence of acids. The acid actually present in the glycol is often sufficient to retard the reaction. Such a technique tends to assure uniform mixing of the ingredients and so facilitates the production of homogeneous products. Pyridine is often added later in the process, usually two hours after the commencement of the milling, so that the reactants are now only slightly acid in reaction.

This reduction in acidity would tend to accelerate the reaction. Other auxiliaries are, however, necessary and water is added to complete the polymerization, the latter appearing to function as a plasticizer and as a lubricant, the composition being further milled for two hours after which time a further amount of water is added. At the end of 15 minutes rubber crumbs are discharged from the mill.

The crumbs may then be placed in a hydraulic press and cured at 150°C for one hour at 2,800 lb. per sq. in., an amber rubbery coloured slab being obtained. A

product made by this technique has the following physical properties:—

Tensile strength	1,225 lb/sq.in.
Elongation at break	460 %
Modulus at 300% elongation	1,100 lb/sq.in.

Experience has shown that when employing the higher molecular weight polyalkylene oxide glycols ($> 3,000$) large excesses of *isocyanates* should be employed (12:1), such amounts enhancing the statistical probability of reaction of *isocyanate* with hydroxyls in the glycol macromolecule. The plasticizing effect of water is important, too little retarding the reaction sufficiently to affect adversely the physical properties of the resulting polymer. Adequate amounts of water are imperative to react with available *isocyanate* groups to give the CO_2 necessary for a closed cell spongy product, the reactants being agitated as little as possible (1).

The known reaction of the *isocyanate* radical with hydroxyl groups is utilized in the manufacture of tyres using polyurethane elastomers. The *isocyanate* radical reacts at the hydroxyls in the hexose moieties of the cellulose molecule and therefore affords a basis for adhesion. In this way rubber-polyurethane tyres may be made. A technique has been devised by the Germans which employs a fibrous interlayer which consists of a free surface of textile fabric and a coated surface consisting of a bonded natural rubber or synthetic thermoplastic composition. The piles may be vulcanized, the sides and treads of the tyre being prepared by pouring a liquid *isocyanate* modified ester into the mould and heating to 110°F . Clutch plates and conveyor belts have also been made using laminates of similar fibrous interlays (2).

Bonding Media

Cellulose acetate has been bonded to aldehyde modified rubbers through the use of di-*isocyanate* solutions (3). A rubber coated fabric for example may be sprayed with a solution containing an aldehyde modified rubber (five parts) in toluene (five parts), to which has been added the di-*isocyanate*. Using such a base, a cast of plasticized

cellulose acetate can be applied, good adhesion being obtained after baking at 150°C for half an hour.

It might be rationalized that the plies of a rubber carcass could be built up in the conventional way, except that the foremost ply could have an uppermost aldehyde-rubber surface. The treads and sides of the tyre could then be prepared by pouring the *isocyanate* modified ester containing free *isocyanate* groups into a mould, the whole being then cured in conventional manner. Methylol groups in the aldehyde-modified rubber would of course react with the free *isocyanate* radicals in the modified ester. These modified rubbers may be prepared by the reaction of formaldehyde-releasing substances on natural rubber.

Rubber Mixtures

Exploiting such concepts also envisages the use of mixtures of rubber chlorhydrin and natural rubber, or if more convenient, by virtue of possible partial solubilities, their eutectic mixtures as the ingredients for the outer ply. Bonding again would be at the hydroxyl in the rubber chlorhydrin.

Fibres have been treated with *isocyanate* modified esters, but the complete chemical absorption by the fibre often obliterates the original textile characteristics. This has led to certain modifications in procedure. The reacting *isocyanate* is limited to the surface of the fibre by a preliminary treatment of the fibre with water, aliphatic or amino alcohols. In this way satisfactory coatings have been obtained.

The technique utilized involves 50 per cent solutions of the modified *isocyanate* ester in benzene, ethyl acetate or their mixtures, the solvents being so selected that they have no solvating action on the fibre or textile being coated. The operation may be speeded up by the employment of the conventional accelerators, the tertiary amines, examples of which are dialkylaminocyclohexanes and the dialkyl piperazines, 0.1 to one per cent of the weight of *isocyanate* polyester being used.

The lacquer-shiny surfaces which tend to be produced in this process may be successfully eliminated by a delustering process involving treatment of the modified fabric with the vapour of ethylene diamine. By this process water-resistant materials for raincoats of multi-layer fabrics useful as automobile hoods may be prepared. The coating of suitable fibres by these modified

POLYURETHANE

polyesters has suggested uses as substitutes for violin strings and as staples for wicker work.

Raincoat material may be manufactured by the following process: Acetate rayon is treated with a solution of ethylene diamine and then dried, so that it contains a residual quantity of water, usually of the order of 10 per cent. The fibre may then be coated with a solution of *isocyanate* modified ester (usually 80 per cent solutions in benzene), the fibre being then dried and treated with amine after each coating. The final operation involves washing with water acidulated with acetic acid (4).

Textile finishing agents have recently been prepared from olefinic *isocyanato* derivatives, such finishing agents being useful in stabilizing wool (5). Such derivatives comprise polymers of the *isocyanato* alkyl vinyl ethers. These polymers have been prepared using dimethyl formamide as solvent and dimethyl azo di-*isobutyrate* as catalyst. Redox pairs may also be used as free radical generators. Reaction of terminal *isocyanates* with ammonia yields carbamido fragments, such appendages being useful in the preparation of polycondensation resins, the latter being useful as coating resins.

Foamed polyurethanes have made important contributions in the contemporary plastics world, particularly in recent years, and patents relating to foamed polyurethanes are of recent origin. Patents, however, relating to the production of polyester *isocyanate* plastics date as far back as 1940 in Germany and the US and to 1941 in Great Britain. The manufacture of these useful foamed products is controlled in the US by three companies—Du Pont, Mobray and Lockheed, respectively, who are all licensors. In this country licences have been granted by Farben Fabriken Bayer. The manufacture of the foam is, however, restricted owing to import licences for the raw materials necessary in the manufacture of the foams.

US Industry's Development

The development of the polyurethane foam industry in the US has also been influenced by German know-how through the Mobray company. Theoretically the production of such foams appears simple on paper, merely being the *in situ* release of

DEVELOPMENT

CO₂ when an isocyanate radical reacts with a carboxylic acid or ester. The foam production, however, is beset with snags since the generation of gases *in situ* is as much a chemical process as a physical one. The quality of the foam may vary from batch to batch, this being possibly due to the variation in the quality of the ingredients employed.

The great advantages of such foams are their chemical inertness and mildew resistance, although other useful properties enable them to be used in soundproofing and as thermal insulating material for winter fabrics. Foams are claimed with volume densities varying from 30 kg. per cubic metre to 120 kg. per cubic metre. Closed cell structures varying from 0.02 to one mm. have also been obtained. These products have been found resistant to a wet heat up to the boiling point of water, and to a dry heat as high as 300°F. The foams may be regarded as virtually chemical resistant; thus, for example, treatment for 56 days at ambient temperatures with 10 per cent sulphuric acid, causes a block of one cu. in. to shrink to 0.9 cu. in., a pulpy layer covering the block, the core remaining unaffected. Alkalis cause greater disintegration of the foam. Due to the solvating action of polar solvents, the adherence of polyurethane foams to textiles should be accomplished by adhesives having non-polar solvents as vehicles.

Production of Foams

The production of suitable foams depends upon the chemical nature of the polyester employed in the operation and also on the quality of the isocyanate employed. Again the type of activator incorporated is important. The shorter the polymethylene chain in the ester, the more brittle appears the foam structure. Too great an acceleration during the polycondensation stage generates a high pressure of gas and would tend to give a coarse cellular structure. The production of discrete cellular interstices is probably therefore related to the reaction velocity of the condensation of isocyanate with ester.

Sponges made from such products are claimed to hold 19 times their weight of water: dense foams are required for carpet underlays, and bedsheets have been manu-

factured from suitable polyurethane foams, such sheets reducing the incidence of bed sores.

Polyurethane plastics have also been procured from organo-silicon modified alkyd resins (6). These products have found applications in the *in situ* formation of core layers for sandwich structures in aircraft. Such useful plastics may be obtained by heating an organo silanol or its polyhydric alcohol condensation product with mixtures of succinic and sebacic acids. This condensation is carried out at 150 to 220°C. A 100 parts of the resulting resin may then be treated with 30 parts by weight of isocyanate.

Related Quality

The quality of the elastomer and foam is related to the acid component of the silico-alkyd resin and is therefore important. To obtain tough workable films, molecules with long waxy chains are preferred, rather than a surfeit of a lower molecular acid which tends to give brittle films. The acid number of the alkyd resin is also important, because it is the factor which determines the amount of carbon dioxide generated *in situ*.

Resins prepared with acid numbers in the range of 35 to 50, for example, yield uniform foams which are both light and strong. A reduction in the acid number, thus reducing the availability of carbon dioxide, affords less spongy masses. Finally, acid numbers below 10 give a syrupy resin useful for adhesive purposes. The foams so produced may be improved by the introduction of filler materials such as china clay, metallic oxides and flowers of sulphur, four parts of zinc oxide for example being used per 100 parts of the organo-silicon modified resin.

REFERENCES.

- (1) BP 731071
- (2) BP 731181
- (3) BP 573932
- (4) BP 692045
- (5) USP 2,727,020
- (6) BP 736953

New Textile Institute Section

At the request of the members of the Textile Institute in the Liverpool area, a new section has been formed there. The decision was made when an open meeting was held on 7 July at the Cotton Exchange Buildings, under the chairmanship of Mr. A. Diaper, E.T.I., vice-president of the Institute. More than 50 members and friends were present at this meeting.



Biazzi plant at Ardeer. In line are three washing vessels connected with the separator. Beyond is the nitrator. Mr. William Boyd is the 'operator'

IMPORTANT steps in the automatic control of nitroglycerine production methods have been taken by ICI Ltd. Nobel Division at the Ardeer, Scotland, factory. A continuous process plant, developed by Dr. Mario Biazzi, a Swiss chemical engineer, has been working since February. The plant, which incorporates a large number of safety devices, is remotely controlled by three men from a console situated, at present, in the nitrating house. Output is 2,500 lb. of nitroglycerine an hour.

By the end of next year, Nobel Division experts hope to have the console installed in a building outside the protective mound of the plant. Then, by means of instruments and closed circuit television, it will be possible for nitroglycerine to be made without the necessity for persons to be in the plant while any explosive is present.

Representatives of the press who went to Ardeer on 5 July to study the manufacture of explosives were told that the Biazzi unit, as installed at the factory (the largest in Europe), is the most advanced of its kind

EXPLOSIVES

in the world, though a somewhat larger plant has been erected in Australia.

ICI do not, however, regard their Biazzi plant as the last word in development; they intend to continue research towards making the process even safer by still further reducing the amount of explosive actually in process, and possibly by the progression from remote control to absolute automation.

In contrast to the Biazzi unit is the batch production of nitroglycerine. One such plant is still operated at Ardeer by methods which are similar to those used when the factory began making this particular explosive in 1873. The batch process, modified in 1901 and 1908, gave way, between the wars, to the Schmid continuous process. There are a number of Schmid plants working efficiently at Ardeer, but the advantages of Dr. Biazzi's method, which he proposed in 1935, are a compact plant and reduced quantity of nitroglycerine under process, leading to the possibility of automatic operation with corresponding increases in the overall safety factor.

The Biazzi nitrating unit at Ardeer is

completely fabricated in polished stainless steel which prevents accumulation of pockets of nitroglycerine.

It consists of a nitrator, a separator, and three mechanically stirred washers. The nitrator is cooled by a sealed spiral system of coils in which sodium nitrate brine at -5°C is circulated during nitration to maintain the temperature at $10^{\circ}\text{--}15^{\circ}\text{C}$. Agitation is provided by a specially designed high speed stirrer, which causes the emulsion to circulate around the cooling coils before it flows off continuously through an overflow to the separator.

Glycerine and mixed acid, metered in the correct ratio, are both fed in at the top of the nitrator. The emulsion of nitroglycerine and spent acid enters the circular separator tangentially, thus imparting a rotating movement to the contents, a movement which helps to accelerate the separation of the nitroglycerine from the refuse acid. Three sight glasses in the separating vessel permit the separating process to be observed.

Separated nitroglycerine flows off continuously from the top of the separator. The spent acid leaves at the bottom, via a

levelling device, to a dilution vessel where a small percentage of water is added to avoid separation of dissolved nitroglycerine. Only in the separator does any free nitroglycerine occur and it is estimated that of the 1,350 lb. of nitroglycerine in the nitrating room only 125 lb. occur free, the remainder being in the comparatively safe emulsified condition.

The acidic nitroglycerine flowing continuously from the separator into the first of three mechanically agitated wash vessels is brought into contact with an equal volume of 12 per cent sodium carbonate solution.

A very fine emulsion is formed in the washers; this emulsion flows from one washer to the other and from the third washing vessel to the final storage house. The three washing vessels provide adequate contact time between the sodium carbonate solution and the acidic nitroglycerine to ensure complete neutralization of the latter.

Feature of the Biuzzi plant is an elaborate system of safety devices to: (a) minimize the effects of a mistake by the operator; (b) attract the operator's attention to the irregular functioning of any part of the unit; (c) allow the operator to act

by Automation

Flowsheet for nitroglycerine manufacture by the Biuzzi continuous process

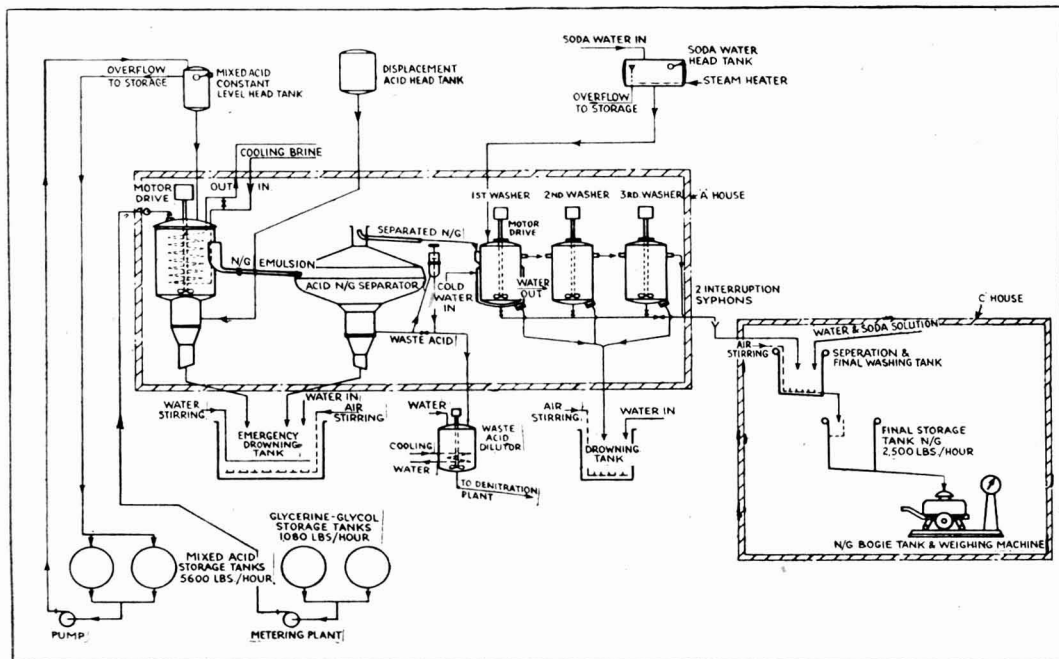

in such a way as to minimize damage which might be caused by such irregularity; (d) set into action automatic devices counteracting any such irregularity should the operator's intervention fail.

For example, the glycerine feeding arm to the nitrator cannot be lowered into its operating position and therefore nitration cannot be commenced unless the production cycle is in order and the safety system energised.

During operation a red blinking-lamp is lighted, a bell rings, and a luminous inscription appears on a glass panel, indicating the cause of the alarm should temperature rise or fall, or flow of mixed acid, soda water, air pressure or brine decrease, or washer stirrer speed be reduced. Red signal lamps are lighted when other dangerous conditions arise.

Visual Indication

A white signal lamp indicates when the security system is switched on, while green signal lamps light when: (a) the waste acid displacement tank is full; (b) the soda water overhead tank is full; (c) temperature in first washer is too low.

An alarm horn sounds when the acid flow is below the safety limit and a pH meter indicator allows the checking at any time of the alkalinity of the nitroglycerine emulsion after the first washer.

Drowning of the charges can be accomplished by hand by means of compressed air valves located at strategic points inside and outside the building.

In case of a general and prolonged power failure the contents of the washers may be stirred by means of compressed air. During operation the glycerine arm is automatically raised from feeding position and the mixed acid and glycerine pumps are stopped if a number of conditions are not satisfied or if the security circuit is not energised.

Contents of nitrator and separator are automatically discharged into a drowning tank, if the temperature in the nitrator or in the separator reaches the second safety limit. When the nitrator and separator are drowned, the contents of the three washers are also automatically drowned in a separate tank.

In case of drowning (automatic or manual), the contents of the main tank are stirred with powerful jets of water until the tank is full. Water is then automatically turned off and compressed air is admitted

to keep the contents further under agitation. All stirrers are stopped when the charge is drowned.

The whole electric security system is powered by a 24 volts battery which is kept charged by an automatic rectifier.

During the visit the press representatives also saw nitroglycerine being made by batch process. They then inspected a blasting explosives manufacturing unit in which numerous mechanical aids are used in the handling and transporting of the explosive as well as in the making and filling of cartidges. Later they watched demonstrations of different types of explosives at the testing station.

In addition to explosives of various kinds, Ardeer factory produces detonators and safety fuses, cellulose derivatives, ether, sulphuric and nitric acids, ammonium and silicone resins. ICI Ltd. claim the highest-percentage of the world trade in explosives.

Indian Sulphuric Acid Plant

FERTILIZERS & Chemicals, Travancore Ltd. has just signed a contract with Chemiebau Dr. A. Zieren GmbH, for the construction of a new sulphuric acid contact plant. This plant will utilize elemental sulphur for the production of 160 tons of monohydrate per day.

The new plant, together with two existing units, makes FACT the largest manufacturer of sulphuric acid in India. The acid will be used partly for increasing the company's production of ammonium sulphate and for a new ammonium phosphate plant.

Oil Refinery for Eire

IT WAS announced on 5 July that the Government of Eire had accepted a joint proposal by the California Texas Corp., Esso Petroleum Co., and Shell Mex and BP to erect and operate a £12 million oil refinery at Whitegate, County Cork.

The capacity of the plant will be 1.6 million tons of crude oil per year or 1.5 million tons of finished products. This is estimated to represent Eire's entire needs for the major petroleum products, motor spirit, automotive and industrial Diesel oils, gas oils and fuel oils, representing 80 per cent of the market in all petroleum products.

When in full operation the refinery will give permanent employment to about 400 men. Construction may take three years.



From all Quarters



Licensing Agreement

A cross-licensing agreement has been signed between Ciba Ltd., of Basle, Switzerland, and Devoc & Reynolds Co. Inc., of Kentucky, US, said to be two of the major patent holders in the epoxy resins field.

Sulphur Plant for Canada

Work is reported to be under way on the new sulphur plant of British American Oil Co., 13 miles south-east of Pincher Creek, Southern Alberta. The plant is scheduled to come into operation in October and initial production will be about 225 long tons of sulphur and 2,200 lb. of condensate daily.

Nobel Prizes for Russians?

An appeal to the Nobel prize committee to make every effort to overcome difficulties in the way of awarding prizes to deserving Russian scientists was made in Göttingen last week by Professor Otto Hahn, president of the Max Planck Society for the Advancement of Science. Professor Hahn, himself a Nobel prizewinner, stated that the Russian authorities should be encouraged to allow their scientists to accept these prizes, as a means of improving international relations between scientists.

Uranium & Thorium Exports from SA

A preliminary estimate by the South African Department of Excise and Customs puts the value of exports in April of prescribed materials (uranium and thorium) under the Atomic Energy Act at £3.5 million, against £771,000 in March. This brings the first four months' total to £10.29 million, against £7.72 million in the corresponding period of 1955.

Union Carbide Building Plans

Union Carbide & Carbon Corporation announces plans for building on its Westchester property near Tarrytown, New York. This is a 280-acre site in the towns of Greenburgh and Mount Pleasant. The buildings will comprise a sales office building, a basic research laboratory to conduct general research for the corporation, and a service laboratory devoted to research work on customers' problems. Construction is due to start early next year.

Society Changes Name

At a special meeting of The Chemical, Metallurgical and Mining Society of South Africa, members decided to change the name of the organization to: The South African Institute of Mining and Metallurgy. The re-naming took effect from the first of this month. The secretaries and address of the institute remain unaltered. The name of the Journal, however, is to be changed to the *Journal of the South Africa Institute of Mining and Metallurgy* and the August 1956 issue will bear this new title. All correspondence should now be addressed to: The Secretaries, The South African Institute of Mining and Metallurgy, PO Box 1183, Johannesburg.

Acetate Yarn Plant for Chile

Celanese Corporation of America announces that the Chilean Government has approved the application of its foreign subsidiary, Celatino SA, for establishment of a multi-million dollar acetate yarn plant near the city of Valparaiso. The plant, the first acetate yarn manufacturing venture in Chile, will have an initial capacity of 3,000,000 lb. annually. It is expected to come into operation within the next 18 months. It will be operated by a newly organized Celanese affiliate company, Celanese Chilena, SA.

Uganda Phosphate Project

Olin Mathieson Chemical Corp. of the US is to join the Uganda Development Corp. Ltd. and Frobisher Ltd., the Canadian mining firm, to develop the phosphate deposits at Sukulu, near Tororo, Uganda. The project is expected to be working fully in 1958. It is also hoped eventually to establish a fertilizers manufacturing concern at Sukulu.

Kenya Pyrethrum Production Up

Kenya's pyrethrum production was well above normal in the first quarter of this year owing to unusually wet weather. Between 1 January and 30 April 1,381 tons were produced compared with 1,019 tons in the same period last year. Applications for planting licences indicate that the acreage under pyrethrum will increase by approximately 20 per cent.

Colonial Progress

Massive Research Programme

IN A Government publication* issued recently, it was revealed that during the past ten years Great Britain has contributed nearly £118 million on schemes under the Colonial Development and Welfare Acts. The sum devoted to research totalled £10 million.

The publication further states that research grants approved during the year under review included £332,701 for medicine, £139,281 for locust control and £281,182 for social science. The University College of East Africa received a grant of £111,850 and from this amount £103,600 was used for the construction of a new chemistry laboratory.

Research schemes attracting grants in this financial year totalled 133. Besides the grants already outlined on this page, there was the provision of £40,100 for the maintenance of the Anti-Locust Research Centre, £43,100 for the West African Building Research Institute and £113,569 for the Institute of Social and Economic Research, West Indies.

Colonial Territories

An additional guide to the lines on which colonial development is being directed, is given in another recently-published Government report, *The Colonial Territories 1955-56* (Cmd. 9769, Stationary Office, 5s). For example, reference is made to the work being carried on at the Sugar Technological Laboratory, Trinidad. The preparation at this laboratory of several materials of commercial value from sugar and its by-products has been developed to a stage where pilot scale examination of the processes is due to be commenced. These by-products include laevulinic acid, lactic acid, oxalic acid and fructose. Further investigation, the report continues, has been made into the antifungal antibiotic Comirin, which was discovered at the Colonial Microbiological Research Institute, Trinidad. However, this study has not been encouraging for its use clinically, though certain horticultural applications appear more promising. At the University College of the West Indies investigations continued successfully on the production and chemical nature of Monamycin.

* Return of Schemes made under the Colonial Development and Welfare Acts by the Secretary of State for the Colonies—1 April 1955 to 31 March 1956, published as House of Commons Paper No. 309 by Her Majesty's Stationery Office, price 2s. 3d.

New Company Formed

THE formation of Efco-Edwards Vacuum Metallurgy Ltd. is jointly announced by Edwards High Vacuum Ltd. and the Electric Furnace Co. Ltd. These two companies are specialists in high vacuum equipment and electric furnace installations respectively and have, for some time, been working together on vacuum metallurgical problems.

The first products of Efco-Edwards Vacuum Metallurgy Ltd. are a range of vacuum melting and pouring furnaces designed for research and production, as well as other standard plant for sintering, brazing, annealing and degassing metals. The policy of the new company is one of constant research and development and larger non-standard furnaces are already on the drawing boards.

Advisory Service Co-operation

AN exchange of views has recently taken place between the British Cast Iron Research Association and the National Industrial Fuel Efficiency Service to ensure that proper co-ordination exists in the technical advice that both organizations offer to the ironfounding industry. It has been agreed that the two bodies can co-operate to the advantage of the industry. Through its liaison services, the BCIRA has been successfully advising ironfounders on specific problems which are encountered in their own works. The field work on fuel undertaken by the Research Association is mainly confined to melting and heat-treatment processes and is necessarily, therefore, smaller than that carried out by NIFES. The latter body an engineering staff organized on an area basis from offices in 15 cities in Great Britain and Northern Ireland.

Kemball, Bishop Sports

Some 400 employees and guests attended the eighth annual sports fete of Kemball, Bishop & Co. Ltd. at Woodford Bridge, Essex, on Saturday 30 June. The inter-departmental challenge shield was won by the general office and staff canteen, with the research laboratory, works and general laboratories as runners-up. Mrs. H. F. Kemball, the wife of Col. H. F. Kemball, T.D., D.L., managing director of the company, presented the prizes.

PEOPLE in the NEWS

MR. T. H. BRAND and MR. J. N. HOGG have been appointed to the board of Borax (Holdings). MR. N. C. PEARSON has been appointed assistant managing director of Borax Consolidated. MR. C. M. HOULTON has been appointed general sales manager and MR. A. G. H. BELL has been appointed assistant sales manager.

COLONEL P. H. LLOYD has been appointed a director of British Tar Products.

Formerly sales manager of Lederle laboratories division, Cyanamide Products. MR. C. GORDON KILLPACK has been appointed head of a newly formed division of the company to handle Aureomycin animal feed supplements, veterinary products and feed preservation products.

MR. G. H. GREENHALGH is to join the Department of Scientific and Industrial Research as scientific attaché in Scandinavia. He succeeds MR. R. G. SILVERSIDES, who has returned to DSIR headquarters.

BENTON H. WILCOXON has been appointed manager of operations of the insecticide division of Olin Mathieson Chemical Corp., it has been announced by R. J. ZIPSE, division general manager. Mr. Wilcoxon was vice-president and general manager of the Calabama Chemical Co. prior to its acquisition by Olin Mathieson. For the past 18 months he has continued to serve as manager of the former Calabama plants. In his new capacity, Mr. Wilcoxon will be responsible for operation of these plants at Huntsville and McIntosh, Alabama as well as Mathieson plants at East Point, Georgia; Omaha, Nebraska; Elkton, Maryland; Aberdeen, North Carolina; Leland, Mississippi, and Fresno, California.

Awards under the Royal Society and Nuffield Foundation Commonwealth Bursaries Scheme have been made to MR. J. HARLEY-MASON, university lecturer in chemistry, Cambridge, to enable him to investigate some West Indian plant products of potential chemical and medical interest, in Jamaica from December 1956 to April 1957;

to DR. R. P. RASTOGI, lecturer in chemistry in Lucknow University, to enable him to study thermodynamic properties of mixtures at Reading and Edinburgh from July 1956 for a year; and to DR. W. M. SMITH, associate professor of chemistry in Queen's University, Kingston, Ontario, to enable him to study kinetics of reactions in the liquid phase, with particular emphasis on fast reactions and the influence of the solvent, at Oxford from July 1956 to June 1957.

DR. J. M. KAY has been appointed to the newly instituted chair of nuclear power at the Imperial College of Science & Technology. In 1952 Dr. Kay was appointed chief technical engineer at the headquarters at Risley, Lancs, of the Department of Atomic Energy's Industrial Group. Since 1955 he has acted as a consultant in nuclear power and related industries.

MR. ROBERT D. WILLIAMS of Caernarvon, chief chemist with the firm of Bernard Wardle (Everflex) Ltd., Caernarvon, has been appointed a director of the firm, whose works are at Peblig Mills, Caernarvon. A native of Wrexham, Mr. Williams, after graduating in chemistry at Liverpool University, was for some time a research chemist at the Paint Research Station at Teddington, Middlesex. Then he served with a firm in Lancaster, joining Bernard Wardle (Everflex) Ltd. in 1949. He became chief chemist shortly afterwards. Mr. Williams is a governor of Flintshire Technical College, Connah's Quay.

MR. E. W. HANCOCK, director and general manager, Humber Ltd., has been elected president of the Institution of Production Engineers for the coming year. MR. H. G. GREGORY, manager of Fairey Aviation Ltd., northern factories, has been elected chairman of the Institution.

MR. J. HOUSTON JACKSON, general manager of the BP Tanker Co., has been appointed a director. He remains general manager. MR. D. G. L. BEAN has been appointed deputy general manager, having been transferred to the BP Tanker Co. from BP Trading.

A former student of Bradford Technical College. MR. J. B. ROBERTS, who has been engaged on research work for some years in the college department of chemistry and dyeing, has received the degree of M.Sc. of Shef-

field University. Mr. Roberts' work, on the structure of wool and the effect of alkalis on wool and other fibres, has been aided by a scholarship established by the Wool Textile Research Council. Another research student of the Bradford college, Mr. W. C. INGAMELLS, has also received a Sheffield M.Sc.

MR. A. A. DUNCAN has been appointed a director of National Plastics, National Plastics (Sales) and British Moulded Plastics. He will be acting as a full-time director at Walthamstow.

MR. ROBERT GILLESPIE has been appointed a director of the British Petroleum Co. He fills the vacancy that has been caused by the retirement from the board of Mr. E. H. O. ELKINGTON on 30 June. Mr. Gillespie joined the British Tanker Co. (now the BP Tanker Co.) in 1922. He was appointed general manager of the British Tanker Co. in 1944, becoming a director in 1946 and managing director in 1950.

MR. W. B. JORDAN, formerly head of market development, is now manager of the Western sales district of the insecticide division of Olin Mathieson Chemical Corp. His headquarters are at Fresno, California.

President of the Academy of Sciences of the USSR, PROFESSOR ALEXANDER N. NESMEYANOV (57), has been elected an honorary fellow of the Royal Society of Edinburgh. He is a chemist and was rector of Moscow University from 1948-51. He led the delegation of Russian scientists who visited this country last November.

COMM. BEUTELSPACHER, manager of Anonima Chimico-Farmaceutica, Milan, has been elected president of the Italian Chemical Trade Association. DR. BOZZI has been appointed vice-president.

DR. GEORGE L. MCCALL has been appointed assistant export manager in the Grasselli chemicals department, the principal agricultural chemicals department of E. I. du Pont de Nemours & Co. Inc., Wilmington, Delaware, US. He succeeds MR. JOSEPH P. CONLON, who is being promoted to a new domestic assignment. In addition to agricultural chemicals, the Grasselli department produces and exports a variety of chemicals for use in the manufacture of textiles, paper, leather, metals,

and chemical specialities. These industrial chemicals are also included in Dr. McCall's responsibilities.

MR. ROBERT W. SANDERS has been appointed supervisor of chemical operations at the Texas Co.'s Lockport, Ill., works, and MR. WILLIAM H. ROACH has been appointed chief chemist at the company's Eagle Point works, Westville, New Jersey. Mr. Sanders, who will be in charge of operations of Texaco's new ammonia plant now under construction at Lockport, joined the company in 1932 and has been chief chemist at the Eagle Point works since 1949. Mr. Roach, who has been on loan from the Texas Co. since 1954 to the Iranian Oil Refining Co., NV, joined Texaco in 1934. From 1953 to 1954 he was chief chemist at Texaco's Lawrenceville, Ill., works.

MR. A. M. SHILLAM, A.C.W.A., has been appointed works director of H. J. Elliott Ltd., laboratory glassware manufacturers as from 1 July. MR. J. T. SIMMONS, works manager, resigned on 30 June.

SIR JACK STEVENS, chairman of the Australian Atomic Energy Commission, announced in Sydney early this week that he will resign to take up a position with a private firm next September.

Wills

MR. THOMAS TUSTING COCKING, F.P.S., F.R.I.C., of 1 The Mall, London N14, former chief analyst to The British Drug Houses Ltd., who died on 25 March last, left £37,664 2s 4d gross, £37,524 9s 7d net value (duty paid £9,226).

MR. CHARLES JOHN PHILLIPS, of Cotswold, 71 Shelveys Way, Tadworth, Surrey, chairman and managing director of Newbery & Phillips Ltd., London WC1, manufacturing chemists and cosmetic manufacturers, who died on 11 March last, left £27,039 1s 8d gross, £26,916 15s 2d net value. (Duty paid £4,860).

MR. FREDERICK SOLOMON RAU of 64 Meadway, London NW11, of Derby & Co. Ltd., bullion dealers etc., director of Brimsdown Chemical Works Ltd., Derby & Co. (Metals & Minerals) Inc., and other companies, who died on 27 March last, left £139,806 8s 7d gross, £130,463 10s 6d net value (duty paid £89,573).

German Atomic Research

Developments Beginning to Bear Fruit

ENERGETIC efforts made in the German Federal Republic to allow the country to participate in atomic research and development are now beginning to bear fruit. The first phase of the work undertaken under the central direction of the Federal Ministry for Atomic Matters, that of legislative and organizational preparation, is approaching its end. An atomic power Bill, drawn up by the Ministry and examined by the other departments concerned, is now being reviewed by an inter-ministerial committee and is to be submitted to the Federal Cabinet shortly. It is hoped that the Lower House will give the Bill a first reading before the Parliamentary recess, but some delay may occur at the Parliamentary stage.

Decentralization Provided For

A fair degree of decentralization is provided for in the Bill, not only to meet regional susceptibilities, but also because establishment of a central research and development organization would involve delays.

Present plans envisage the erection of research reactors near Munich, Frankfurt, Hamburg and Karlsruhe. A contract for the first of these, a swimming pool reactor with an initial capacity of 100 kW to be set up 10 miles north of Munich, has been placed with the American Machine & Foundry Co., New York. It is to be delivered in eight to 10 months; the cylindrical concrete tank will have a diameter of about four metres and be eight metres high; it will be built by AMF Ducee, a German contractor company. Provisions have been made for future increase of the reactor capacity to 1,000-2,000 kW, and the Federal Ministry for Atomic Affairs will bear a substantial part of the cost of the reactor which may be about DM 1,500,000.

A swimming pool reactor is also to be ordered for Hamburg, where the Society for the Promotion of Nuclear Energy Utilization in Shipbuilding is in charge of the research work; a boiling water reactor is to be installed for work in the Frankfurt area. The latter installation appears to be connected with the plans in the Land of Hesse where DM 12,600,000 have been earmarked for re-

search and training at university colleges. An Institute of Nuclear Physics is to be established at Darmstadt in 1957, and this is to be followed by erection of a research reactor, at an estimated cost of DM 4 million, in 1958.

In Berlin the plans for an atomic research centre seem to hang fire because of differences between two departments of the city administration; the economic department would like a 500-1,000 kW reactor to be operated in conjunction with industrial firms, while the education department wants a Noll reactor of 50 kW for work at the two universities. For either project the consent of the Allied authorities will have to be obtained.

Several German industrial companies have publicly stated their interest in the atomic field, but it is only now that formal arrangements for industrial participation in the erection and operation of an atomic reactor are being made. These concern installations at Karlsruhe where the Federal Republic, Land Baden-Wurttemberg and private interests will participate in the ratio of 3:2:5 in the foundation of Kernreaktor Bau- und Betriebsgesellschaft mbH, a non-profit making enterprise with funds of about DM 40 million. The private interests will be represented by Kernreaktor-Finanzierungs-GmbH which will have a capital of DM 20 million divided into shares of DM 100,000 each, of which individual companies may however hold several.

Founder Members

Among the founder members of the latter company are Farbenfabriken Bayer, Farbwerke Hoechst, Deutsche Gold- und Silber-Scheideanstalt, and Metallgesellschaft—all well known for their chemical and metal interests—Allgemeine Elektrizitäts-Gesellschaft and Siemens-Schuckert—the two leading heavy electrical engineering groups—as well as the heavy engineering groups Fried. Krupp, Demag and Gutehoffnungshütte, and Physikalische Studiengesellschaft Düsseldorf.

A working group of the last-mentioned organization was responsible for the planning of the Karlsruhe reactor which was undertaken in advance so as to make an immediate start on the building work. The

same sense of urgency is reflected by the founder companies' decision to provide a substantial part of the total capital immediately, subject to a proviso that participation in the enterprise is to be open to any German company interested in the venture and that a DM 100,000 share will be ceded to any newcomer with a small premium for expenses.

While all the reactors to be put into operation in the next five years will be obtained from abroad—two, or possible three, reactors are to be ordered in this country—the Federal Minister for Atomic Matters, Herr Franz Josef Strauss, has expressed the view that thereafter German atomic physicists will be able to work with prototypes of their own, even though they will still depend on supplies of fuel elements and certain special parts from abroad. Each of these reactors is to be given a special research task while retaining as much scope for independent initiative as possible.

The electricity supply industry has expressed interest in atomic power in somewhat general terms, but one of the leading supply companies, Vereinigte Elektrizitätswerke Westfalen, has stated its intention to make an early start with the erection of atomic power stations. The company hopes to draw on experience gained in the operation of atomic power stations in this country. It is generally thought in Germany that the first atomic power stations will be in operation by 1966 at the latest.

Automation 'Not New' Greater Skill Needed

AUTOMATION ('that ungainly word') was the subject of comment by Sir Alexander Fleck, chairman of ICI Ltd., when he spoke at the company's annual general meeting in London on 14 June. Sir Alexander said that although the word is new, the ideas behind it are not. 'For decades', he went on, 'we have been applying schemes of advanced mechanization, backed by effective instrumentation, together with increasing use of automatic controls. Many of our (ICI) processes already operate continuously and it is largely by developing the application of the most up-to-date technical knowledge that we have been able to raise our productivity as rapidly.'

Stressing again that automation is not new, but merely the continuing extension of

a process which has for long been a normal feature of ICI operations, Sir Alexander declared, 'In our industry we certainly do not regard these changes as revolutionary, nor do we think they are likely to cause unemployment or other major difficulties'. For the country as a whole he would go further; employment would only be maintained if British industry kept abreast of the world in technical efficiency. That meant the extension of automation and continued heavy capital expenditure.

'The nature of work is itself changing', continued Sir Alexander, 'with a need for greater skill and intelligence in every kind of industrial activity. We believe it is possible for management to ensure that the necessary adjustments are so made, and so timed, that individual hardship is avoided, or at least minimized'.

On the subject of technical education he said that the Government have shown definite evidence of being alive to the ever-increasing need for technically-trained people. But future requirements were still not fully appreciated. Much would have to be done in this educational field, by the Government and by industry itself, if Britain was to hold her own with other nations.

Additions to KID List

THE Board of Trade has made the Safeguarding of Industries (list of dutiable goods) (Amendment No. 10) Order, 1956, adding the following chemicals to the list of chemicals liable to Key Industry Duty:—

Antazoline hydrochloride, 2-chloro-1:4-diethoxybenzene, *p*-chlorothiophenol, *ditert*-butyl peroxide, 2:4-dichlorophenyl benzene-sulphonate, dimethyldichlorosilane, hexamethyldisiloxane, methion, methyl ethyl ketone peroxide, methylphenyldichlorosilane, methyltrichlorosilane, naphthazoline hydrochloride, naphthazoline nitrate, peracetic acid, piperazine adipate, piperazine dihydrochloride, piperazine sulphate, piperazine tartrate, pyridoxine hydrochloride, trimethylchlorosilane, tripiperazine diphosphate.

E-Mil Works Holiday

H. J. Elliott Ltd. announces that its E-Mil Works, at Treforest, Glam., will be closed for the annual holiday from Saturday 28 July to Tuesday 14 August. During this period only a skeleton office staff will be maintained at Treforest. The company's London regional office will not close.

LEGAL STUDIES

by Peter Pain MA

IMPORTING A PATENT

LAATEST issue of the *Reports of Patent Cases* contains a decision of some interest with regard to the registration in this country of an invention made abroad. It relates to a gas mask, which is described as a 'disposable mask' because it is cheap enough to be thrown away after being used once, thus avoiding the need for sterilization. Used for the administration of oxygen and other gases, it consists of a bag like member of flexible gas-proof material, such as polyvinyl chloride, with means for shaping the mouth of the bag to, and retaining it on, the face.

Patented in the US

The mask was invented and patented in the US. The inventors assigned the patent to an American company, which granted a licence including the right to export to another American company, Air Reduction Co. Inc. H. wrote from Britain to this company saying that the mask had received good publicity in the UK and asking what the possibilities were of obtaining a licence to manufacture it here or of purchasing masks from Air Reduction direct. He asked for a sample. Air Reduction replied sending a sample together with a descriptive leaflet and saying that they would not be prepared to grant a licence, but would be happy to sell to H. H. wrote back expressing certain doubts as to the import position and saying that he would make enquiries.

Without another word to Air Reduction he then made application to register a patent relating to the mask in his own name. Not surprisingly Air Reduction opposed this application and the proceeding reported arose out of their opposition.

Section 14 (1) (a) of the Patents Act 1949 provides that a person may oppose the grant of a patent upon the ground (among others) 'that the applicant for the patent, or the person described in the application as the true and first inventor, obtained the invention or any part thereof from him.'

The application came first before the Assistant Comptroller General and a long and learned argument took place on what would seem to the layman to be the fairly obvious question—had H. obtained the in-

vention from Air Reduction? The difficulty arises because of another principle established many years ago. This principle treats a person who brings into this country an invention made by someone else abroad, as the first and true inventor in this country (provided of course that the invention has not been brought here previously).

Reference was made to the famous Clothworkers of Ipswich Case (decided in 1615) which justified this principle on the ground that it was necessary to encourage the man 'who hath brought in a new invention and a new trade within the kingdom in peril of his life and consumption of his estate.'

Conflict between these principles was summarized in this way. Did H. by the letter he wrote, or Air Reduction by the package it sent in reply, really introduce the invention into this country? If the answer were H. then he was to be regarded as the first and true inventor. If the answer were Air Reduction, then H. was not entitled to the grant of a patent in that he neither devised the invention nor introduced it from abroad.

Was the law to show itself an ass? H. had not imperilled his life nor consumed his estate except to the extent of 5d. in stamps. The Assistant Comptroller after an erudite discussion of the decided cases held that H. had obtained the invention from Air Reduction and was accordingly not entitled to register the patent.

Appeal to Tribunal

Nothing daunted H. appealed to the Patent Appeal Tribunal, which consists of a High Court Judge, Mr. Justice Lloyd Jacob. The Judge upheld the decision of the Assistant Comptroller, but based his decision on different grounds.

In giving his judgment he called in aid yet another principle of patent law. This principle says that if the opponent of grant can prove that he communicated the invention to the applicant, before the applicant made his application, that will be taken as proof that the applicant obtained the invention from him. But this is a presumption which can be rebutted if the applicant can show that he made the invention him-

self or that it was invented by some other person through whom he derives title to it.

The Judge said that it was quite clear that the package containing the sample and descriptive leaflet were sent to H. before he made his application. Therefore he could only escape the presumption that he had obtained the invention from Air Reduction by showing that he had made it himself or obtained it from someone else. He attempted to do this by saying that his first letter showed that he already knew of the invention. On this point the Judge's words were:—

'A letter of request for information cannot of itself be said to establish the possession of the alleged invention and in so far as this applicant ever was possessed of information with regard to this invention he derived it, and derived it solely from the information contained in Mr. Kuhn's reply (from Air Reduction) which was dated 1 June 1951. In these circumstances the opponents having satisfied me that they were responsible for the communication which ante-dated this application, they have established, as I understand the cases, that the invention was obtained from them.'

See *Reports of Patent Cases*, 1956, p. 197.

Chemical Expansion

ACCORDING to a preliminary annual summary, Canada's chemicals and allied products industries broke new ground in 1955 when the factory value of shipments passed the billion-dollar-mark for the first time. The year's value was \$1,050,000,000, an increase of about 12 per cent over the preceding year's \$936,000,000.

Within the chemicals group, nearly all industries made positive contributions to the record total factory value of shipments by registering increases over 1954. Percentage increases over 1954 were (by industries) as follows: heavy chemicals, 23.5; compressed gases 12; fertilizers, 19; medicinals, 7.7; paints, 11.7; soaps, 8.5; toilet preparations, 13; inks, 10; polishes, 10.3; primary plastics, 28.2; miscellaneous, 8.1. Declines of 4.4 per cent and 16.3 per cent were recorded by the vegetable oils and adhesives industries, the decline in the latter being due for the most part to a reclassification of firms to other industries. In 1955 the 1,112 operating establishments (1,116 in 1954) employed 51,463 persons (51,603) and paid out

\$184,434,000 in salaries and wages (\$177,312,000).

The rising tempo of economic activity last year was accompanied by a substantial increase in imports of chemicals and allied products. As has been historically the case, the United States continued to supply the bulk of the demand for these products and in 1955 accounted for 84.0 per cent of the \$265,000,000 versus 86.4 per cent of the preceding year's \$220,400,000. At the same time Canada exported chemicals to the value of \$210,000,000, an increase of almost \$50,000,000 over 1954. The United States was the largest customer, accounting for 53.2 per cent of the total.

Chemical producers indicated their intention to spend \$165,000,000 during 1956 for new equipment in the form of plants and machinery. This is about 2½ times the total spent in 1955 and in magnitude represents an amount only slightly lower than the combined total of \$177,000,000 spent in the 10 year period ending in 1949.

New Industrial Exhibition

AT an inaugural press reception at the Waldorf Hotel recently, details were given of the Instruments, Electronics and Automation Exhibition which is to be staged at Olympia, London, from 7-17 May 1957. The exhibition will be the first of its kind, covering the complete field of laboratory and industrial instrumentation and the ever-growing uses of electronics. Promoted by five trade associations, it is being arranged on their behalf by a newly-formed exhibition organization—Industrial Exhibitions Ltd.—headed by Mr. T. E. Rees, until recently deputy to the managing director of British Industries Fair Ltd., Mr. Kenneth Horne. Complementary to the exhibition will be a continuous programme of conferences, lectures and meetings, which will provide the opportunity for full discussion and consideration of the many and varied problems arising from the rapidly changing pattern of industrial development and the use of new techniques in industry.

Change of Address

Safety Products Ltd. has moved to Holme-thorpe Avenue, Redhill, Surrey (telephone Redhill 4304/5).

Safety Notebook

THE *London Gazette* has printed a list of some 300 officials of the Ministry of Labour and National Service who have been given the special task of carrying out inspections for the purpose of ensuring compliance with section 36(7) of the Factories Act, 1937. The need for the check was brought to light by the inquiries into a fire at Keighley earlier this year in which lives were lost.

Generally speaking this check will apply to chemical factories. The sub-section in question refers to factories where more than 20 persons are employed in the same building, or explosive or highly inflammable materials are stored or used in any building in which persons are employed. Although in a number of the smaller chemical factories there may not be 20 persons in any one building, there will generally be explosives or highly inflammable materials in a building in which employees work. The Factories Act does not give any special definition to 'explosive' or 'highly inflammable', so that these words are to be understood in their ordinary sense.

This check is unlikely to cause any embarrassment in the large factories, which generally have a safety officer whose duty it is to make sure that the Factories Acts are observed. But a few words as to the general position may be helpful to the managers of smaller factories, who have a hundred and one jobs on their plate and no time to make a special study of the Acts.

Warning in Case of Fire

The section requires effective provision to be made for giving warning in case of fire. The warning must be clearly audible throughout the building. No specific type of warning is required—that is left to individual discretion. But it is clear that it must be a pretty loud type of warning. Just how loud depends on the process being carried on; if the machinery is noisy then the warning must be so much the noisier, for the section obviously means that the warning must be audible in the circumstances in which people work, and not simply audible when the factory is idle. It must be loud enough to

draw the instant attention of someone who is concentrating on something else.

The provision must be 'effective' which means that it must be related to the risk in the particular factory. Obviously there must be a means of control at the central point, such as the timekeeper's office. But this may not be enough. Where there is a high fire risk at one place, means of operating the alarm should be ready to hand so that an employee can give immediate warning. In the same way it may be necessary to have several controls in the case of a factory which is widely scattered. After the experience of Keighley one can be sure that the Ministry officials will be pretty thorough in their requirements.

Other Provisions

They may also pose a few questions as to whether the other provisions of the Factories Act in regard to fire are being dealt with and a few words about these are therefore in point. Little need be said as to the means of escape in case of fire, as the factory is not permitted to operate until it has obtained a certificate from the local authority that these are satisfactory. But Ministry officials may wish to satisfy themselves that the means of escape are being maintained in a proper condition.

It is the duty of the occupier of every factory in which more than 20 persons are employed in the same building above the first floor, or more than 20 ft. above ground level, or where explosive or inflammable materials are stored or used in any building in which persons are employed, to take steps to ensure that all persons employed are familiar with the means of escape in case of fire and their use, and with the routine to be followed in case of fire. Note that it is not sufficient that employees know the means of escape; they must be 'familiar' with it. This will hardly be possible of achievement, unless practice alarms are organized from time to time.

Doors of the factory must not be locked while persons are inside; nor may they be so fastened that they cannot be easily and immediately opened from the inside. This

applies to all doors on the way out. All doors giving on to a staircase or corridor must open outwards; so must all other doors in a factory constructed or converted since 1 July 1938. This does not apply to sliding doors, which are quite in order. In pre-July 1938 factories in which more than 10 persons are employed in the same building above the ground floor, any door at the foot of a staircase affording a means of exit shall be kept open, or be a sliding door, or open outwards.

Hoistways and liftways inside a building constructed after 1 July 1938 must be completely enclosed with fire-resisting materials; the means of access must be fitted with doors of fire-resisting materials; at the top there must be a vent or some material which can easily be broken in case of fire.

Every window, door or other exit forming part of the means of escape must be clearly and conspicuously marked in red letters. The contents of every room in which people work must be so arranged that there is a free passage way for all employees to a means of escape in case of fire.

Increase in Profits

African Explosives & Chemical Industries

CONSOLIDATED trading profits of African Explosives & Chemical Industries at £3,321,226 for 1955 compare with £3,124,022 for the 15 months ended 31 December 1954, when the financial year was changed. The steep increase is attributed to the completion of several of the company's schemes, which now have come into production.

Taxation totalled £1,002,862, against £845,448, and the remaining profit was £1,973,246, against £1,965,788. It has been proposed to pay the same dividends totalling £1,312,500, or a total of 2s 6d on each ordinary £1 share. The assets increased in 1955 from £30,562,666 to £34,160,386, and the increase was financed partly by loans, the total of which mounted from £7,106,062 to £9,106,062. It is now proposed to increase the authorized capital by £8,000,000 of ordinary shares to £23,000,000, which will be placed under the control of the directors. The present issued capital is £13,500,000, of which £3,000,000 constitutes preference capital.

In his review the chairman, Sir Ernest Oppenheimer, states that sales of explosives

increased in the year, and estimates of future requirements indicate the need for further expansions of manufacturing capacity. The increase from fertilizer sales would have been greater if the new sulphuric acid factory at Umbogintwini had started production in time, but it began producing only this year.

A full year's output was obtained from the first stage of the ammonia sections at Modderfontein. The second stage was started during 1955 and the third, increasing the investment to £6,000,000, will be completed soon. Work started on this project in 1948, and only in 1954 the company began to receive a return. Further expansion is planned. After a review of the other activities of the group, Sir Ernest stated that the titanium undertaking would be established at Umbogintwini, from where it could draw its sulphuric acid. Ilmenite would be obtained from sands of the Natal south coast.

Ramsay Memorial Fellowship

THE RAMSAY Memorial Fellowship Trustees have made the following awards of new Fellowships in chemistry for 1956-57 to: Dr. M. J. Stephen, a General Fellowship at the University of Oxford; a Glasgow Fellowship to Mr. G. S. Harris at the University of Cambridge; a Canadian Fellowship to Mr. A. H. Webster at the University of Cambridge; a Netherlands Fellowship to Dr. C. H. Stam at the University of Leeds and a United States Fellowship to Mr. P. B. Sherry at the University of Oxford. The trustees have renewed the following Fellowships for the same year:— Mr. B. R. Hammond (General Fellowship) at the National Institute for Research in Dairying, Reading; Mr. E. Haslam (General Fellowship) at the University of Cambridge; Mr. H. Inokuchi (Japanese Fellowship) at the University of Nottingham; Dr. R. Vicente and Mr. F. Garcia-Moliner (Spanish Fellowships) at the University of Cambridge.

Coke Oven Contracts Placed

Simon-Carves have received contracts amounting to about £4½ million from the Steel Company of Wales for new coke oven construction in connection with the recently-announced £48-million development programme at the Margam steelworks. When the new construction is finished there will be a total of 310 post-war coke ovens, all built by Simon-Carves, at Margam works.

Convention of Chemical Science

THE 1956 Convention of Chemical Sciences will be held in Paris from 18 November to 3 December, at the same time as the IVth Salon de la Chimie—Caoutchouc—Matières Plastiques. This will include several meetings of particular importance, notably the XXIXth International Congress of Industrial Chemistry, the 1st European Congress of Corrosion, the European Conference of Chemical Engineering and the Paris Technical Meetings.

The International Congress of Industrial Chemistry, which will consist of 21 sections, will be held from 18 to 24 November at the Maison de la Chimie.

The European Congress of Corrosion will also take place from 12 to 24 November at the Maison de la Chimie. Its work will be divided into eight sections which will be concerned with all aspects of corrosion and its prevention.

The European Conference of Chemical Engineering will include three symposia on calculations of converters, calculations of reactors, and extraction by solid adsorbants. These symposia will take place in the Conference Hall of the IVth Salon de la Chimie in the Palais des Congrès at the Porte de Versailles on 22, 23 and 24 November.

The Paris Technical Meetings will also be held at Versailles, from 26 November onwards. They will include a series of specialized symposia dealing with polar and tropical equipment, plastics materials, natural and synthetic rubber, control and regulation, analysis and methods of test.

From 22 November to 3 December the IVth Chemical Rubber and Plastics Exhibition will be held at the Parc des Expositions, Porte de Versailles. Over a thousand exhibitors of equipment, processes and products are expected to take part.

Libyan Oil Storage Terminal

Work has commenced on an oil storage terminal which is being constructed for the Esso Standard (Near East) Inc. in the Benghazi port area of Cyrenaica. It is hoped that on completion of this project a higher grade of petrol will become available.

New Uranium Detection Method

A new and cheap method for the detection of underground deposits of uranium by indirect means, where natural sources of water and gas occur, is reported to have been developed by an Israel scientist.

MARKET REPORTS

LONDON.—Trading conditions on the industrial chemicals market remain good notwithstanding a seasonal quietness which is beginning to affect some of the main consuming industries. The export demand for chemicals has also been on a satisfactory scale. Among the soda products there has been a steady call for yellow prussiate, dichromate and chlorate of soda, while there has also been a good movement in the potash compounds. Prices generally remain steady with a firm undertone and at the time of this report no outstanding changes have been notified. Both home and export business in creosote oil and cresylic acid continues along steady lines, and there is a ready outlet for most of the other coal-tar products.

MANCHESTER.—In the aggregate, contract deliveries of heavy chemicals to the textile and other industries in the Lancashire and West Riding areas have been affected by annual holiday stoppages, which are now almost at their peak, and from the point of view of fresh bookings the Manchester market during the past week has also been somewhat less active. With an odd exception, values continue on a steady to firm basis. A moderate business in fertilizers has been confined to one or two sections, including those where early delivery rebates obtain. The demand for most of the light and heavy tar products has been fairly steady.

GLASGOW.—The general position in the Scottish heavy chemical market during the past week has been fairly active, and a reasonable volume of business has been maintained. As reported last week, some price increases are still taking place. On the agricultural side the demand continues brisk and, with regard to export, the usual flow of enquiries is being received, and the market continues satisfactory.

New Fruit Fungicide

A new light-coloured fruit fungicide which has given good finish on apples in a number of field tests has been announced by the Du Pont Company. The new material is based on thiram (tetramethyl thiuramdisulphide) which has been thoroughly tested as an apple fungicide for several seasons in the US.

Publications & Announcements

A MONTHLY journal, *Chemical Industry News*, has been launched by the Indian Chemical Manufacturers' Association, of Calcutta.

Writing in the first issue, the president of the association, Mr. Charat Ram, says that 'in spite of the fact that the chemical industry is one of the largest industries in the country it has had no journal of its own. In this modern chemical age the chemical industry plays a vital part in the country's economy by providing basic chemicals for industrial development and essential drugs and pharmaceuticals to alleviate human suffering. There is not, however, sufficient recognition of the role of this industry in national development. I have every hope that this journal of the ICMA will fulfil a long-felt need by focusing public attention on the problems and prospects of this industry.'

* * *

BRITISH STANDARD 2718:1956 specifies materials, dimensions and constructional requirements for gas cylinder trolleys primarily intended for use in hospitals. Two patterns are specified in sizes related to oxygen cylinders of 24, 48, 120 and 180 cu. ft. capacity, but the trolleys are suitable also for the carriage of cylinders of compressed air and other gases. As a precaution against risks arising from the discharge of static electricity, all rubber on the trolleys is required to be of anti-static composition and the base plates supporting the cylinders are required to be finished with a conductive metallic coating. Copies may be obtained from the British Standards Institution, 2 Park Street, London W1, price 3s 6d.

* * *

THE QUARTERLY edition of *Heat Engineering*, published by the Foster Wheeler Corporation, New York, contains news of the erection of a 100 tons per day Casale ammonia plant at Cubato, Brazil. The work is being carried out by Brazilian nationals under the supervision of Foster Wheeler construction engineers. The placing 'on stream' of this plant in the autumn of this year will complete a co-operative effort of engineers on three continents to help raise the standard of living of some fifty million Brazilians. In addition to supplying daily 100 tons of 99.5 per cent (liquid volume) am-

monia, the plant will also provide one million cu. ft. of hydrogen per day. The feed streams for the project consist of refinery gas from a nearby refinery plus atmospheric air and high pressure steam (400 psig).

The synthetic manufacture of ammonia combines a series of six process steps as follows: air separation, synthesis gas generation, shift conversion, carbon dioxide removal, liquid nitrogen wash and ammonia synthesis. The Foster Wheeler magazine also records the launching of the Sinclair *Petrolore*, the World's largest combination oil-ore carrier and which is powered with FW steam generators. The tanker has a net cargo capacity of 403,000 bbl—this can be pumped at the rate of 29,600 bbl per hour. When in full service as a combination carrier, the *Petrolore* will carry oil from Kuwait to Marcus Hook by way of the Cape of Good Hope, will travel empty from the Sinclair refinery to Venezuela, will engage in ore service from Venezuela to Japan, and will travel empty from Japan to Kuwait.

* * *

SURVEYS carried out by the Food and Agricultural Organizations of the United Nations have established that insect pests are responsible for the loss of millions of tons of stored food products every year. Elimination of the known wastage, the surveys have further revealed, would approximately double the total tonnage of surplus exportable food crops now entering world trade. These facts are referred to in the introduction to a new technical booklet on 'Embafume' brand methyl bromide, published by May & Baker Ltd., of Dagenham, Essex. Methyl bromide, the booklet states, is now being used on a rapidly increasing scale in the war against the pests. The preparation will destroy almost every insect pest at any stage of development, from the egg to the adult insect, and will control a wide range of parasites if properly applied. The manufacturers claim that the 'Embafume' brand, compared with other fumigants, leaves smaller residues (in most cases none at all) and is less likely to impart an objectionable odour or taste to the majority of foodstuffs. Under favourable conditions there is little or no loss of germinating power of seeds.



DIE TECHNIK DER NEGATIV- UND POSITIV-VERFAHREN. By E. Mutter. Springer Verlag, Vienna. 1955. Pp. xx + 396. 112s 6d.

This monograph on negatives and positives is part of a larger work, 'Die Wissenschaftliche und Angewandte Photographie' which is being published under the general editorship of Dr. Kurt Michel to replace the classical treatise on photography by Hay and von Rohr. Other titles which have been announced include 'Das photographische Objektiv', 'Die Kinematographische Kamera' and 'Mikrophotographie'; further volumes are in preparation.

The present volume differs fundamentally from most manuals of photography in that it pays considerable attention to the theoretical basis of the subject. This is especially apparent in the first section which includes chapters on the properties of emulsions, the formation of the latent image and the theoretical aspects of the developing process. These chapters give excellent brief surveys of accepted theories, and provide a great number of literature references for the reader who requires more detailed information. Another chapter in this section deals with photographic chemicals and gives useful facts concerning purity and toxicity.

In the later sections, a wealth of practical information is presented against a sound theoretical background. Processes discussed include desensitization, hypersensitization and latent image intensification, as well as developing, fixing, washing, drying, intensification, reduction etc. Positives are discussed briefly in a separate section, but colour processes will be covered in a later volume. An excellent chapter on defects in negatives and positives illustrates the author's gifts for classification and condensation. Another valuable feature of the book is a lengthy chapter (80 pages) of recipes.

This book should appeal strongly to the

practical photographer as well as to the student of photographic processes, and its companion volumes are awaited with interest.—J.P.C.S.

THE LIFE OF LUDWIG MOND. By J. M. Cohen. Methuen & Co. Ltd., London, 1956. Pp. 295 with 16 halftone plates and a text illustration. 22s 6d.

Although Dr. Ludwig Mond, who died nearly 45 years ago, was one of the greatest scientific industrialists of the Victorian age and a key figure in the social history of Victorian and Edwardian England, this book is the first biography of him to be written. The author has, therefore, not only made a valuable contribution to the field of historical literature, but has bridged an important gap which has existed in the records of chemical industry developments for all too long.

In a foreword, Sir Alexander Fleck (chairman of ICI) states that the reader is clearly shown how Mond considered the possibility of establishing himself in several chemical processes, and how he finally chose one which was destined for success. The fact that Ludwig Mond was fortunate in his choice, however, does not detract from his insight, his imagination and his Herculean capacity for work. Quite apart from the clearly-drawn portrait, Sir Alexander continues, the book throws light on the progressive changes that have taken place in chemical knowledge, in methods of manufacture, in the size of firms, and in industrial relations. The reader, with his unthinking acceptance of present-day conditions, cannot help comparing them with those of a past era when Mond's ideas were regarded as revolutionary by the business world of the time. As Sir Alexander points out, nowhere is the contrast more striking than in the comparison of the initial stages of the Brunner-Mond partnership with the activities of ICI, of which Brunner,

Mond became part in the merger of 1926.

Here indeed is the story of a great man who rose from humble circumstances to heights far beyond any which he himself ever dreamed. Born in Cassel, Germany, in 1839 of orthodox Jewish parents, Ludwig Mond was educated under the distinguished German scientists Kolbe and Bunsen. He brought to England a continental training in method and quick understanding. After first applying himself to various problems of wastage in the soda industry, he went on to perfect an alternative method of soda manufacture—which is followed to this day. Beginning with a little painfully-raised capital and a partner of financial skill, he built up the business of Brunner, Mond, the kernal of the present ICI. The story of this evolution is skilfully woven into the author's narrative of Mond's family life.

RESONANCE IN ORGANIC CHEMISTRY. By G. W. Wheland. John Wiley & Son Inc., New York; Chapman & Hall Ltd., London. 1955. Pp. xiii + 846. 120s.

Since publication of the author's famous earlier book, *The Theory of Resonance and its Application to Organic Chemistry*, there have been many developments in the subject. Professor Wheland has incorporated the more significant of these in the present volume. This, despite his high standards of selection, has led to a book of considerably greater length than its predecessor. More important reasons for the expansion, however, are the introduction of a section on the molecular orbital method and its status in relation to the valence bond one, and a long concluding chapter on the mathematical basis of resonance.

Professor Wheland has an established reputation for clarity and he has now further enhanced it. The concept of valence bond resonance probably offers greater possibilities of obscure and ambiguous presentation than any other single chemical idea. This is because it has a quantum mechanical basis, and it is never easy to translate quantum mechanics into the language of everyday chemistry. Indeed it can only be done properly by a very good teacher who knows the subject intimately and has contributed to its development. Professor Wheland eminently combines these rare qualifications.

General plan of the present book follows fairly closely that of the earlier one. Its scope may be indicated by the chapter headings which are: (1) Theory of Reson-

ance, (2) Nature of Valence, (3) Resonance Energy, (4) Steric Effects of Resonance, (5) Resonance and Dipole Moments, (6) Resonance and Molecular Equilibrium, (7) Resonance and Chemical Reactions, (9) Mathematical Basis of Resonance.

There is also a very valuable appendix of bond length and angle data. This is practically complete and runs to one hundred and five pages. The book is elegantly produced and free from misprints.—H. MACKLE.

New British Standards

THE British Standards Institution announces the publication of BS 2751, *Vulcanized Butadiene/Acrylonitrile Rubber Compounds*, and BS 2752, *Vulcanized Chloroprene Rubber Compounds*.

These continue the series started with the issue of BS 1154, *Vulcanized Rubber Compounds*, and BS 1155, *Vulcanized Extruded Rubber Compounds and Tubing*, specifically intended for Government department use.

Each standard covers five synthetic rubber compounds ranging from 41° to 88° BS hardness and gives details of compositions which, however, allow some latitude to the manufacturer in formulating his mixes, together with details of skeleton mixes which have been found to meet the requirements of the standard. The standards also specify requirements for physical properties, together with the necessary methods of test.

Copies of these standards are obtainable from the Institution's sales branch at 2 Park Street, London W1, price 2s 6d each.

Non-flam Hydrazine

A COMPLETELY non-flammable form of hydrazine for deoxygenation of boiler feedwater has now been placed on the market by the Olin Mathieson Chemical Corporation, Called Scav-Ox, the product is a 35 per cent solution of hydrazine in water. It is said to have no flash point and no fire point, yet retains all of the advantages of hydrazine as an oxygen scavenger and corrosion inhibitor.

Hydrazine has found limited application in boiler feedwater treatment for several years, but handling precautions necessitated by its flammability have confined its use principally to large consumers such as power generating stations.

Parliamentary Topics

WHEN the Minister of Supply, Mr. Reginald Maudling, was asked in the House why the Government would not allow Mr. Lang, the former assistant solicitor to ICI, to appeal to the tribunal, in view of the Government's decision that the Civil Service procedure of the tribunal should apply to cases which arose in industry, Mr. Maudling replied that the responsible Ministers had previously considered the case with great care, at great length and with all the information at their disposal.

ANSWERING a question recently, Mr. R. A. Butler, Lord Privy Seal, announced that an expert committee of the British Standards Institution, assisted by the Atomic Energy Authority, was preparing a uniform nomenclature covering the field of nuclear science and equipment. The Government was also giving its support to a programme which had been drawn up by the Organization for European Economic Co-operation for establishing a uniform nomenclature among its member countries. He added that the glossary of terms would be published by the BSI in due course.

SIR David Eccles, Minister of Education, has refused to recommend to the Hives Committee that the new qualification in technology should be a degree and not a diploma. He considers that the power to confer a degree has become the distinguishing mark of a university.

Ambulance Awards

MEMBERS of the fire brigade at the ICI Randle works (General Chemical Division), Runcorn, won several trophies at the British Fire Services Association national tournament held at Bognor Regis from 2 July to 6 July. In the junior one-man ambulance drill they gained first, second and third places and in the senior class of the same drill they were first. They came third in the two-man ambulance drill, first in the four-man ambulance drill and were runners-up in the national first aid final. ICI Randle also received high marks for BA drills.

Pollution Action Settled

MONSANTO chemicals Ltd. has paid £14,000 damages and £5,500 costs to eight riparian owners on the river Dee, North Wales, in settlement of their action alleging pollution of the river by effluent from the company's chemical works. Under the agreed order there will be a perpetual injunction against the company, but the injunction will be suspended until 30 June 1958 to enable Monsanto to find a solution to the problem. The damages are in respect of past claims and any further pollution consequent upon the suspension.

There were also complaints about groynes built into the river which, according to Mr. Charles Russell, Q.C., for plaintiffs, 'had the effect partly of filling up some of our salmon pools and partly of acting as a standing temptation to those who wished to fish our water from the end of the groyne.' The company had agreed to demolish four of the groynes and not to allow anyone to fish from another.

The injunction restrained the company from sensibly altering the quality of the water to the injury of the plaintiffs where the river flowed past or over any part of their land, and from interfering with the enjoyment of seven of the plaintiffs of the right of fishing.

Plastics Abstracts

STEPS are being taken to make better known overseas the service offered by the British Plastics Federation in publishing each month abstracts from technical articles in journals throughout the world dealing wholly or partly with plastics developments. The service includes the publishing of patents from the countries that have an important plastics industry.

The abstracts service costs £10 10s a year, post free. Abstracts are available in bound or unbound versions, the latter being printed on one side only. Photostat or microfilm copies of most articles can also be obtained from the Federation at 47-48 Piccadilly, London W1.

At present, abstracts go to 26 overseas countries, Australia, US and Russia being the largest three buyers. Others taking the abstracts in quantity include Germany, Holland, France, Czechoslovakia, China, South Africa and the Scandinavian countries.

Commercial Intelligence

The following are taken from the printed reports, but we cannot be responsible for errors that may occur.

Mortgages & Charges

(Note.—The Companies Consolidation Act of 1908 provides that every Mortgage or Charge, as described herein, shall be registered within 21 days after its creation, otherwise it shall be void against the liquidator and any creditor. The Act also provides that every company shall, in making its Annual Summary, specify the total amount of debt due from the company in respect of all Mortgages or Charges. The following Mortgages or Charges have been so registered. In each case the total debt, as specified in the last available Annual Summary, is also given—marked with an *—followed by the date of the Summary but such total may have been reduced.)

ALLIANCE (MANCHESTER) LTD., dealers in chemicals etc.—14 June, £2,975 charge and a charge collateral thereto, to Friends' Provident & Century Life Office; respectively charged on 8 Sandiway, Knutsford, and a policy. *£3,085. 7 October 1953.

F. W. BERK & Co. LTD., London WC, chemical manufacturers.—13 June, four charges each securing £2,245, to St. Albans RDC; respectively charged on 128, 130, 132 and 134 The Ridgeway, St. Albans. *Nil. 31 May 1956.

N. L. COWLING (CHARLTON) LTD., colour merchants.—12 June, two charges, to Westminster Bank Ltd, each securing all moneys due or to become due to the Bank; respectively charged on 482 & 484 Woolwich Road, 1 & 2 Armstrong Gardens and certain land at Armstrong Gardens and on Earlswood Laundry, Armstrong Gardens, Charlton. *Nil. 12 July 1955.

Increase of Capital

CHAS. FORTH & SON LTD. (315,080), chemical merchants etc., North Gate, New Basford, Nottingham, increased by £10,000 in £1 ordinary shares beyond the registered capital of £10,000.

New Registrations

Cassenne Laboratories Ltd.

Private company. (568,100). Registered 27 June. Capital £1,000 in £1 shares. Objects: to carry on the business of whole

sale and retail chemists and druggists, laboratory proprietors etc. The subscribers (each with one share) are:— Evelyn J. Robertson, The Moorings, 211 Richmond Road, Kingston-on-Thames, Surrey, secretary; Arline Posner, 72 Evelyn Avenue, Kingsbury, London NW9, secretary. The first directors are to be appointed by the subscribers. Solicitors: Forsyte Kerman & Phillips, 11 Mansfield Street, London W1.

Cuthbertson Chemical Industries Ltd.

Private company. (31,591). Registered in Edinburgh 9 June. Capital £500 in £1 shares. Objects: To carry on the business of producers, manufacturers, refiners and exporters of fats, mineral oils, vegetable oils etc. The subscribers (each with one share) are: J. A. Cuthbertson, 512 Anniesland Road, Glasgow W3, director of James Cuthbertson & Co. Ltd.; D. E. Cuthbertson, 512 Anniesland Road, Glasgow. The first directors are not named. Registered office: 337 Bogmoor Road, Glasgow.

Howard Baker (Proteins) Ltd.

Private company (568,500). Registered 4 July. Capital £10,000 in 9,998 preference and two ordinary shares of £1. To carry on the business of manufacturers of or dealers in all kinds of feeding stuffs, cattle foods, proteins, organic and inorganic fertilizers, animals by-products, fats and oils etc. Directors: Benjamin Howard Baker, Dormy House, Gayton Hall, Wirral; Philip Howard Baker, Coach House, Gayton Hall, Gayton, Wirral, directors of B. H. Baker & Co. Ltd. etc. Secretary: William T. Horsfall. Solicitors: Laces & Co., Liverpool. Reg. office: 16 Wood Grove, Liverpool 13.

Bulk Oil Plants Ltd.

Private company. (568,375). Registered 2 July. Capital £5,000 in £1 shares. Objects: To establish, acquire, operate and grant rights of operation over installations, mills and factories for handling, manufacturing, processing and storing all kinds of vegetable oil, oil-bearing fruits and seeds, etc. The subscribers (each with one share) are: Louis P. Ojukwu, 32 Commercial Avenue,

Yaba, Lagos, Nigeria, company director; and Eric C. R. Measures, 65 Georges Wood Road, Brookmans Park, Hatfield, Herts, company director. The first directors are to be appointed by the subscribers. Solicitors: J. D. Heywood, Unilever House, London EC4.

Organic Laboratories Ltd.

Private company. (568,338). Registered 30 June. Capital £1,000 in £1 shares. Objects: To carry on the business of manufacturers, extractors and processors of and dealers in industrial, fine, pharmaceutical and reagent chemicals, gases, drugs, medicines, disinfectants, fertilizers etc. The subscribers (each with one share) are: Denis Frankel and John L. Lannan, both of 21 Ely Place, London EC1. The first directors are not named. Solicitors: Franks Charlesly & Leighton, 21 Ely Place, London EC1.

Plastic Filters Ltd.

Private company (568,476). Registered 4 July. Capital £1,000 in £1 shares. To carry on the business of chemical engineers and fabricators in corrosion resistant materials and dealers in plastic materials etc. Subscribers (each with one share) are: Mrs Eileen M. King, 27 Jackdaw Close, Langley Green, Crawley, Sussex; Horace B. Squires, Partney Oak, Domewood, Cophorne, Sussex. Horace B. Squires is the first director. Reg. office: 39 High Street, Crawley, Sussex.

Company News

British Glues & Chemicals Ltd.

Consolidated profit of British Glues & Chemicals Ltd. for the year ended 31 March 1956 is £749,065, compared with £860,126 last year. Net profit, after providing for UK tax amounting to £361,000, is £388,065. After deducting £19,648 profit retained by the subsidiary companies the profit dealt with in the accounts of the parent company is £368,417, compared with £413,756 last year. A half-yearly dividend of 4 per cent is recommended on the preference stock, making 8 per cent for the year. On the ordinary stock a final dividend of 12 per cent making the total dividend for the year equivalent to 15½ per cent on the present issued capital of £1,260,000 (last year 20 per cent equivalent to 13½ per cent on the present issued capital).

Badische Anilin- & Soda-Fabrik AG

The annual general meeting of Badische Anilin- & Soda-Fabrik AG was held in

Ludwigshafen/Rhine on 30 May. According to the report presented by the board of directors, business during 1955 was in accordance with expectations. Turnover reached DM1,261 million (£107.7 million), an advance of 20.1 per cent compared with 1954. Profit for the year ended 31 December was DM38,171,818. To this is added DM292,222 carried forward from 1954, making a net profit of DM38,464,040. BASF's share in the total turnover of the German chemical industry amounted to 9.4 per cent, against 8.2 per cent in the previous year.

The Morgan Crucible Co. Ltd.

The profit of this company for the year ended 31 March 1956 was £815,501. This was after charging taxation, £1,096,444, and deducting minority interests, £33,062, and profit retained in subsidiary companies. The balance brought forward from the previous year was £48,897, making a total profit of £864,398. Dividends paid accounted for £155,471, leaving a balance of £708,927. The directors have recommended a final dividend of 6½ per cent and a centenary bonus of one per cent. In his statement to shareholders the chairman says that the record figures of trade and profit realized in 1954/55 have been exceeded in the year under review. Profits, however, have not risen in proportion to the increase in volume of sales, owing to growth and severity of competition abroad and strains on the industrial economy at home. The consequent shrinkage of profit margins has been only partially offset by a modest improvement in productivity. The 22nd annual general meeting of the company will be held on Wednesday, 25 July.

Permalit Ltd.

Gross trading profit for the year ended 31 March 1956 of Permalit Ltd. was £130,844 compared with £124,979 for the previous year. During the year under review, says the chairman in his annual statement, the company acquired the manufacturing plant, processes and goodwill of a company making a product known as Jabroc, which is similar to Hydulignum a product of Hodern-Richmond Ltd., a subsidiary of Permalit. Permalit have set up a further division which is devoted to the manufacture of glass laminates, to be marketed under the trade name of Permaglass. The 19th annual general meeting of the company will be held in London on 31 July.

CLASSIFIED ADVERTISEMENTS

SITUATIONS VACANT

ORGANIC CHEMISTS required by a firm of insecticide and fungicide manufacturers near London, for research and development work in this field. Applicants must have at least 1st or 2nd class Honours Degree or A.R.I.C. and some post-graduate or industrial experience. The appointments are permanent and pensionable. Commencing salaries up to £1,100, progressive and according to age and experience. Write in confidence, giving full details of qualifications and experience, to:—**BOX NO. C.A. 3485 THE CHEMICAL AGE, 154, FLEET STREET, LONDON, E.C.4.**

VESSEL ENGINEERS required by major Contractor to the Petroleum and Chemical Industries for its Project Engineering Department. Duties include preparation of basic design calculations and specifications, analysis of tenders and recommendations for selection of vendor, correspondence with vendors and customers, review of vendors' drawings, etc. Applicants should have minimum qualification of H.N.C. and some experience of vessel design and construction. Salary range £800 to £1,100 per annum, depending on qualifications and experience. Write to **BOX No. C.A. 3479, THE CHEMICAL AGE, 154, FLEET STREET LONDON, E.C.4.**

DEVELOPMENT CHEMICAL & MECHANICAL ENGINEER

APPPLICATIONS are invited for a senior appointment in the Development Department of a well-known Company engaged in the design and manufacture of large scale chemical plant. Applicants should hold a Science or Engineering Degree, and have an established ability in the direction and control of development projects. This appointment will be a key post in the organisation, and the salary will be commensurate with the responsibilities of the post. Applications giving details of qualifications, experience and salary required to:—**BOX No. C.A. 3484, THE CHEMICAL AGE, 154, FLEET STREET, LONDON, E.C.4**

TECHNICAL REPRESENTATIVE is required by the Chemical Division of B.X. Plastics Ltd., to initiate a sales development programme on a new project. A degree in chemistry is essential and sales experience, particularly in the paint trade, is desirable. The successful candidate will be based at Brantham and will be expected to travel widely in the United Kingdom. Applications stating age, qualifications and experience should be sent to the **PERSONNEL MANAGER, B.X. PLASTICS LTD., BRANTHAM WORKS, NR. MANNINGTREE, ESSEX.**

BILLINGHAM



DIVISION

ENGINEERING RESEARCH DEPARTMENT

ENGINEERS PHYSICISTS

The small particles field in the chemical industry offers unusual interest and considerable scope in research and development for physicists and engineers. The work already done at Billingham is widely recognised as notable, and a varied programme is continuing on size analysis, dedusting, grinding, etc. An extended investigation of a large-size electrostatic precipitator is at present being made. Publication of research results is encouraged. This work is an example of the activity of the Engineering Research Department in the Billingham Division.

Applications are invited from physicists and chemical and mechanical engineers interested in research work for appointments as Technical Officers. Candidates should have an Honours Degree and be below 40 years of age.

These appointments are permanent and pensionable, and good starting salaries are offered. There is a profit-sharing scheme in operation and assistance can be given towards house purchase. The Company also makes grants towards removal expenses in the case of married men.

Write, giving brief details of age, qualifications and experience, to the Staff Manager, Imperial Chemical Industries, Limited, Billingham Division, Billingham, Co. Durham, quoting reference W/B.7.

FOR SALE

CHARCOAL, ANIMAL AND VEGETABLE, Horticultural, burning, filtering, disinfecting, medicinal. Also lumps, ground and granulated. **THOMAS HILL-JONES, INVICTA WORKS, BOW COMMON LANE, LONDON, E.3 (TELEPHONE EAST 3285).**

MIXERS—1 Baker Hand-tilted Trough, 16 in. by 24 in. by 20 in. Fast and loose pulleys and clutch. "Z" blades.

1 Ditto Power-tilted Trough, 30 in. by 20 in. by 24 in. Pulley drive and clutch. Four "L" blades.

**THOMPSON & SON (MILLWALL), LTD.,
LONDON, E.14.
TEL.: EAST 1844.**

PHOSPHOR-BRONZE 'Z' MIXER, with Jacketed Tilting Pan, 30" x 28" x 22".

STAINLESS STEEL 'Z' MIXER, about 5 gal. Two speeds. Built-in A.C. Motor.

JACKETED 'RIBBON' BLENDER, 50 gallons.

STAINLESS STEEL 200-gal. Pan with Electric Agitator. Water Jacketed.

25 GALLON CHANGE PAN or Pony Mixer.

20 GALLON DETACHABLE BOWL Electric Mixer.

REVOLVING DRUM, 6' x 2' 4" wide.

EDGE RUNNER with 5' Granite Base.

WILKINSON OINTMENT MILL, 18".

WINKWORTH MACHINERY LTD., 65 High Street, Staines. Tel.: 1010.

**MORTON, SON AND WARD, LIMITED,
STAINLESS STEEL VESSELS**

VESSELS of all shapes and sizes, jacketed or unjacketed —with stainless steel mixing gear to requirements; also stainless steel storage tanks and vacuum vessels.

"MORWARD" "U"-shaped TROUGH MIXERS—up to 2 tons, in stainless steel, with agitators, scroll or paddle type, jacketed or unjacketed.

Stainless Steel TROUGHS, TANKS and CYLINDERS made to requirements.

These items can also be fabricated in mild steel.

JACKETED PANS

100g., 150g., and 200g., new, in mild steel, for 100 lb. p.s.i. w.p.—with or without mixing gear.

3 cwt. **TROUGH MIXERS** by **CHALMERS and GARDNER**—stainless steel-lined troughs.

50g., 75g. and 100g. heavy duty **MIXERS** by **FALLOWS and BATES**. Agitators driven through bevel gears from fast and loose pulley.

200g. cast-iron **JACKETED MIXING VESSEL** with nickel-chrome impeller type agitator driven through bevel gears from fast and loose pulley.

BROADBENT HYDRO EXTRACTORS

21 in. **EQUAL TO NEW**, galvanized baskets, electrically driven through centrifugal clutch or belt driven. Safety inter-locks.

AIR COMPRESSORS

THREE 30 c.f.m. at 100 lb. pressure, water cooled, automatic overloads, with or without motors.

ONE AEROGRAPH motorized air-cooled compressor, electrically driven, fitted with overloads and mounted on receiver, 100 lb. working pressure.

AIR RECEIVERS MADE TO REQUIREMENTS

PUMPS

Selection of new **MONO** and second-hand **Pumps** in stock—2 in. to 5 in.

Inquiries Invited.

MORTON, SON AND WARD, LIMITED,

WALK MILL,

DOBCROSS, NEAR OLDHAM,

Lancs.

Phone Saddleworth 437

600

MIXERS

1-TON Horizontal Single Trough POWDER MIXER by Gardner—8 ft. by 3 ft. by 41 in. deep, of $\frac{1}{2}$ in. mild steel Scroll-type agitator.

Double-Trough Type TILTING MIXER—trough 32 in. by 32 in. by 24 in. deep. Fitted double "Z"-type agitator. Pulley drive.

Unused Single TROUGH MIXER by Lang—22 in. sq. by 28 in. deep. Mild steel galvanised construction with cast ends. Sigma-type contra-rotating agitator driven through spur gearing.

Double-Trough Mixer—34 in. by 27 in. by 26 in. deep. Twin "Z" blades. Single spur gearing. Hand tilting, hinged cover. Motorised 400/3/50.

TROUGH MIXER by Morton—twin "Z" blades. Trough 20 in. cube. Pulley drive. Hand tilting.

Four Unused DEGESTERS or Horizontal PRESSURE MIXERS by G. Hopkins—50 gal. capacity. 19 $\frac{1}{2}$ in. diam. by 36 in. with 11 in. radius ends. Construction $\frac{1}{4}$ in. copper. Horizontal three-blade perforated agitator. Speed 120 r.p.m. Motorised 400/3/50 through reduction gear.

Horizontal SIFTER/MIXER by D. Burr—trough 5 ft. by 2 ft. by 30 in. deep. Broken scroll-type agitator. Motorised.

13 Totally Enclosed SOLUTION MIXERS—12 ft. long by 6 ft. 6 in. diam. Capacity 10,000 litres. Construction mild steel plate, with dish ends and heavy glanded spiral-type agitators. Motorised 400/3/50. Mounted on mild steel stands. Vessels have top manway 18 in. diam. and 7 in. by 2 in. diam. bottom outlet. W.P. 70 lb.

Size "C" Gardner SIFTER/MIXER with timber hopper 18 in. by 9 in. by 9 $\frac{1}{2}$ in. deep, and brush sifter over mixing chamber 24 in. by 14 in. by 16 in. deep. Scroll-type agitator.

Trough MIXER by Baker Perkins—phosphor-bronze lined trough 16 in. sq. by 14 in. deep, fitted twin P.B. blades.

GEORGE COHEN SONS & CO., LTD.,

WOOD LANE, LONDON, W.12.

Tel: Shepherds Bush 2070 and

STANNINGLEY, NR. LEEDS.

Tel.: Pudsey 2241.

MOISTURE TEST—THREE MINUTES—Already in use in many industries where rapid determination of water content of chemicals, colours, glazes and other raw materials is essential. **"SPEEDY" MOISTURE TESTER** has proved accurate and invaluable. Portable, needs no electricity, no skill. Complete £27 10 0. Order direct or send for illustrated leaflet to (Dept. C.A. 1) **THOS. ASHWORTH & CO., LTD.,** Vulcan Works, Burnley, Lancs.

PHONE 98 STAINES

(12) 5,000 gal. **GLASS-LINED CYLINDRICAL ENCLOSED TANKS**—18 ft. by 7 ft. 6 in.

(8) Ditto, 2,000 gal., 13 ft. by 6 ft.

(3) Stainless Steel-Lined Autoclaves—6 ft. by 3 ft. 100 w.p.

(2) **STAINLESS STEEL GAS-HEATED PANS**—23 in. by 19 in. deep.

STAINLESS STEEL JACKETED PAN—100 gal., 36 in. by 38 in., 60 lb. w.p.

(2) **STAINLESS STEEL TIPPING PANS**—2 ft. 6 in. by 2 ft. 4 in. deep.

(2) **STAINLESS STEEL JACKETED CYLINDRICAL MIXERS**—39 in. by 32 in. and 40 in. by 24 in. A.C.

STAINLESS STEEL AND CHROME STIRRERS/EMULSIFIERS— $\frac{1}{2}$, $\frac{1}{4}$, $\frac{1}{8}$ and 2 h.p. A.C.

(Unused) PORTABLE MIXING ARMS—25 in. shaft, 400/3/50.

MIXERS, PUMPS, CONDENSERS, HYDROS, STILLS, TANKS AND PANS, DRYERS, OVENS, etc.

HARRY H. GARDAM & CO., LTD.

For Sale—continued

MILK DRYING PLANT, comprising: Little used Simon Twin-roll Drier, 82 in. × 28 in. diam. Motorized. Stainless steel external Calandria type Vacuum Evaporator by Apex, duty 50 gal. hr. evap. with Surface Condenser, 50 gal. Receivers, Vacuum Pump etc.

GEORGE COHEN SONS & CO. LTD.
WOOD LANE, LONDON, W.12.
Tel.: Shepherds Bush 2070 and
STANNINGLEY, NR. LEEDS
Tel.: Pudsey 2241.

WANTED

INDUSTRIAL BY-PRODUCTS, LTD., 16, Philpot Lane, London, E.C.3. will be pleased to receive particulars of any by-products, waste materials and residues for disposal.

WORK WANTED & OFFERED

CRUSHING, GRINDING, MIXING and DRYING for the trade.

THE CRACK PULVERISING MILLS LTD.

Plantation House,
Mincing Lane,
London, E.C.2.

GRINDING, CRUSHING AND GRADING

FINE GRINDING LTD.,
BLACKHOLE MINE, EYAM
TELEPHONE: EYAM 227

PULVERISING of every description of chemical and other materials. Collections, storage, deliveries. **THOMAS HILL-JONES, LIMITED, INVICTA WORKS, BOW COMMON LANE, LONDON, E.3 (TELEPHONE EAST 3285).**

SALE BY TENDER

THE BOARD OF TRADE has for disposal 1,000 flasks of **MERCURY** of good commercial quality, each weighing approximately 86 lb. gross and reputedly 76 lb. net. Full particulars and Forms of Tender (returnable by 27th July, 1956) may be obtained on application to the Board of Trade, C. & G.8(b), Room 301, Lacon House, Theobalds Road, London, W.C.1. (Telephone No.: CHAncery 4411, Extension 295 or 310.)

BUSINESS OPPORTUNITY

HIGHLY Qualified Experienced **TECHNOLOGIST** seeks active full-time interest in company situated London area, manufacturing Industrial Chemicals. Substantial funds available for investment. **BOX No. C.A. 3480, THE CHEMICAL AGE, 154, FLEET STREET, LONDON, E.C.4.**

INVITATION TO TENDER

TENDERS are invited from Manufacturers who can supply the produce from their own manufacture for the supply of 375,000 tons Ammonium Sulphate, 88,000 tons Urea, 89,000 tons Ammonium Sulphate Nitrate, and 10,000 tons Calcium Ammonium Nitrate. Supply required in long tons, for delivery in instalments during January to August, 1957, C. & F. Indian port of discharge/F.O.B. stowed port of exit.

For specifications and further details apply immediately to **DIRECTOR GENERAL, INDIA STORE DEPARTMENT, GOVERNMENT BUILDING, BROMYARD AVENUE, ACTON, LONDON, W.3**, quoting reference S.917/56.GR/CIV.

AUCTIONEERS, VALUERS, Etc.

EDWARD RUSHTON, SON AND KENYON
(Established 1855).

Auctioneers, Valuers and Fire Loss Assessors of
CHEMICAL WORKS PLANT AND MACHINERY

York House, 12 York Street, Manchester.

Telephone 1937 (2 lines) Central Manchester.

For Classified Advertising THE CHEMICAL AGE

Gives direct and immediate penetration. Is the recognised liaison between buyer and seller.

Accepts advertisements up to first post on Tuesday for insertion in that week's issue.

Gives a reduced rate for more than three insertions and

PULLS IN RESULTS

The rates are 5d. per word (approx. 7 words to a line) or 30/- per inch semi-displayed.

Send your classified advertisements for Invitations to Tender, Situations Wanted and Vacant, Articles for Sale, and Miscellaneous Requirements to:—

THE CHEMICAL AGE

BOUVERIE HOUSE, FLEET STREET, LONDON, E.C.4

Telephone: Fleet Street, 3212 (26 lines)

KEEBUSH

Keebush is an acid-resisting constructional material used for the construction of tanks, pumps, pipes, valves, fans, etc. It is completely inert to most commercial acids; is unaffected by temperatures up to 130°C; possesses a relatively high mechanical strength, and is unaffected by thermal shock. It is being used in most industries where acids are also being used. Write for particulars to—

KESTNER'S

5 Grosvenor Gardens, London, S.W.1

CALDER VALE GLASSWORKS LTD

Calder Vale Rd. · Wakefield · Yorks

TEL. WAKEFIELD 3857

• SPECIALISTS IN •

**Carboys · Demijohns
Winchesters**

FOR ALL TYPES OF BOILERS

Durability
Efficiency

Patents
207123
490306
581396

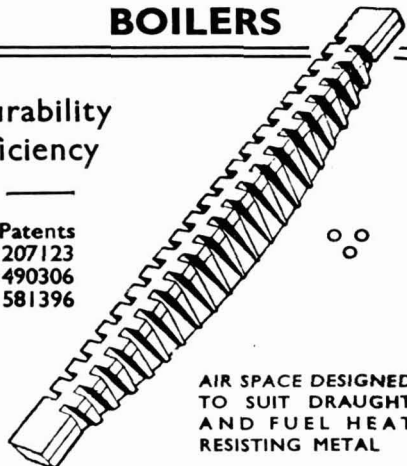

AIR SPACE DESIGNED
TO SUIT DRAUGHT
AND FUEL HEAT
RESISTING METAL

COLLINS IMPROVED FIREBARS, LTD.

51, THE MALL, EALING, LONDON, W.5
T N. Ealing 4070

*Famous
Links*

Staveley Chemicals are the
"Links" between raw
materials and finished
products in industry.

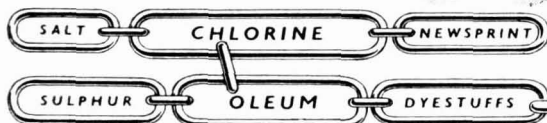
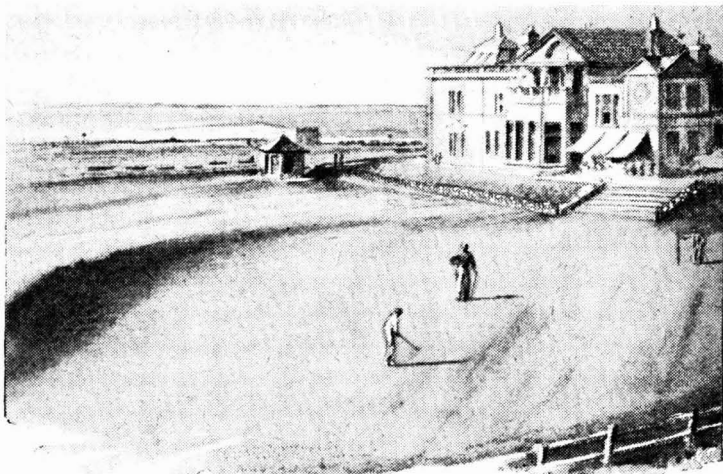

STAVELEY

The Old Course
at St. Andrews.
A view of the
18th hole.

BASIC CHEMICALS FOR INDUSTRY

THE STAVELEY IRON & CHEMICAL CO. LTD.

NR. CHESTERFIELD

INDEX to advertisers in this issue

	Page		Page
Armour & Co., Ltd.	52	Metropolitan-Vickers Electrical Co., Ltd.	Cover iv
British Railways, British Transport Division	53	Mond Nickel Co., Ltd. (The)	57
Calder Vale Glassworks Ltd.	95	Morgan Crucible Co., Ltd. (The)	58
Classified Advertisements	92, 93, 94 & 95	Moritz Chemical Engineering Co., Ltd.	50
Clydesdale Chemical Co., Ltd. (The)	50	Nederlandsche Verkoopkantoor voor Chemische Producten N.V.	51
Cole & Wilson Ltd.	54	Powell, Duffryn, Carbon Products Ltd.	60
Collins Improved Firebars Ltd.	95	Price, Stutfield & Co., Ltd.	Front Cover
Cromil & Piercy Ltd.	Cover ii	Roco Products Ltd.	56
Gallenkamp, A., & Co., Ltd.	Cover iii	Staveley Iron & Chemical Co., Ltd. (The)	95
Hopkin & Williams Ltd.	55	Steel, J. M., & Co., Ltd.	60
Kestner Evaporator & Engineering Co., Ltd.	95	Wells, A.C., & Co., Ltd.	Cover ii
Key Engineering Co., Ltd. (The)	Cover ii	Wynn Valves Ltd.	49
Leitch, John W. & Co., Ltd.	96	Zeal, G. H., Ltd.	54
Lennox Foundry Co., Ltd.	56		
Lord, John L., & Son	Cover iv		

Fast Bases: Yellow GL, GCL; Scarlet GGSL, RL, RCL, GL, GCL, GGL; Red BL, GL, GGL, BBL, GGGL, RL; Garnet GBL, GBCL, GCL new; Corinth BL; Blue RL.



LEITCH

Chemicals for Colour

John W. Leitch & Co. Ltd. Milnsbridge near Huddersfield

PARTICLE SIZING BY SEDIMENTATION

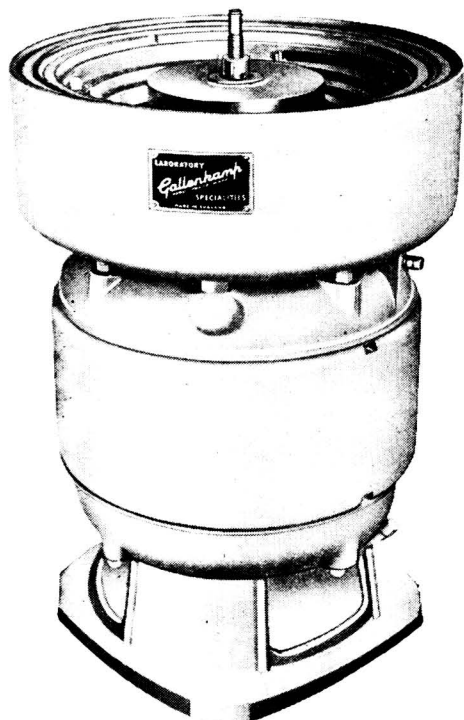
The need for size analysis of particles considerably less than 2μ is assuming increasing industrial importance. The new Gallenkamp Centrifugal Sedimentometer fulfils this requirement. It gives accurate particle size distributions in the range 5μ to 0.1μ , the sedimentation time being reduced by means of high acceleration.



- ★ High reproducibility.
- ★ Sampling time at 500 r.p.m.: 15 minutes to 2 hours according to characteristics and size range.
- ★ Supernatant liquid removed whilst head is still rotating.
- ★ Deposit on strips consolidated by centrifuging at 1,500 r.p.m.
- ★ $\frac{1}{2}$ h.p., 3-phase synchronous motor; stepped rotating head cast in hiduminium; vibration free and silent; phosphor bronze strips; secure safety cover.
- ★ Easy operation; simple maintenance.

Write for publication No. 574

GALLENKAMP

A. GALLENKAMP & CO. LTD.
SUN STREET, LONDON, E.C.2

TELEPHONE : BISHOPSGATE 0651 (9 lines)

TELEGRAMS : GALLENKAMP, AVE. LONDON

"STILL LEADING"

For **CHEMICAL & ALLIED TRADES**

**ACID RESISTING
CEMENTS & LININGS**

**For PICKLING TANKS, FLOORS,
DIGESTERS, KIERS,
STONE, CONCRETE,
BRICK, WOOD,
IRON VESSELS
& ACID
TOWERS**



RESISTS
Formaldehyde,
Alcohol, Oils, Greases
and Tar Acids, Benzene
Toluene Compounds HCl
H₂SO₄, HNO₃, and H₃PO₄
mixed HNO₃ and HF Acids,
Aqua Regia, Formic, Acetic, Lactic
Oxalic, Chromic Acids, Bisulphites,
Hypochlorites, Mixed Acids, Per-
oxides, Nascent Halogens and Alkalies.
UNDER STEAM PRESSURES

RIZISTAL

SOLE MAKER OVER 60 YEARS' EXPERIENCE

JOHN L. LORD & SON
WELLINGTON CEMENT WORKS
BURY, LANCASHIRE

TELEGRAMS "CEMENT"
PHONE BURY 617

The Latest



...in air-filter inspection

*See at a glance
with a*

METROVICK FILTOMETER

This low-priced easily installed instrument—something entirely new on the market—makes the routine inspection of air-conditioning filters quick and easy. The ordinary method of withdrawing each cell for visual inspection is time-wasting and laborious, cells in good condition often being needlessly removed. With the Filtometer permanently fitted across the filter battery the need for cleaning can be judged by a glance at the dial pointer. A valuable feature is the finger operated spring-return valve which safeguards the indicator from being clogged with dust, the valve being open only when a reading is being taken.

N.B.
Available in the standard
ranges of 0 to 0.5, 0 to 1.5
or 0 to 3 inches of water.
Other ranges can be supplied
if required.

Length 7 inches
Depth 3 1/4 inches

Send for leaflet E.S. 4352/1

METROPOLITAN-VICKERS ELECTRICAL CO LTD, TRAFFORD PARK, MANCHESTER 17
Member of the A.E.I. group of companies.