

Chemical Age

CHEMICALS in
LANCASHIRE
and CHESHIRE
(page 541)

VOL. 77 No. 1968

30 March 1957

SULPHUR

"Daffodil Brand"

DOUBLE REFINED ROLL SULPHUR

99.8/100%

SUBLIMED FLOWERS OF SULPHUR

B.P. and Commercial

POWDERED SULPHUR

All meshes

DISPERSIBLE SULPHUR

WETTABLE SULPHUR

BLACK SULPHUR

GREEN SULPHUR

"ALL GRADES FOR ALL TRADES"

Home Trade & Export

PRICE STUTFIELD & Co., LTD.

110, FENCHURCH STREET,

LONDON E.C.3.

Phone:
Royal 7011/2

Cables:
Exconsex, Fen, London

IC *experience** COUNTS

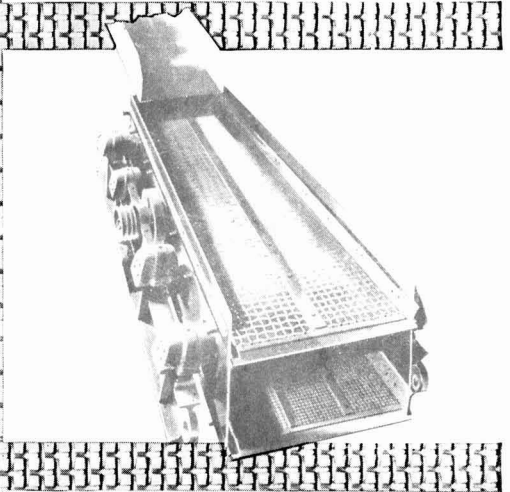
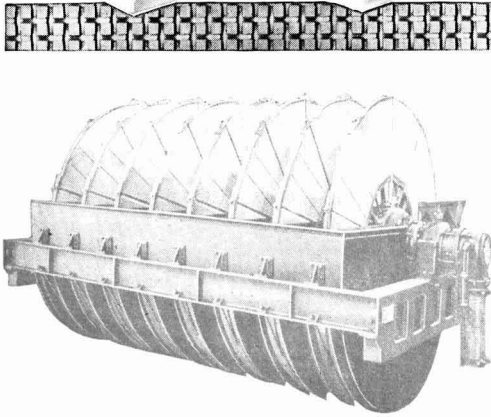
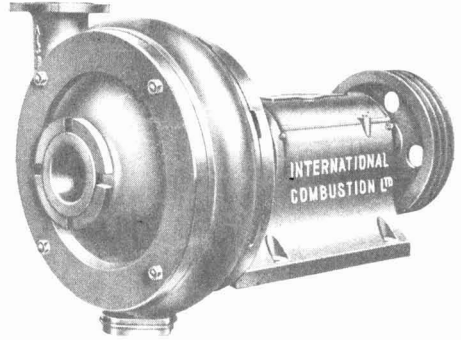
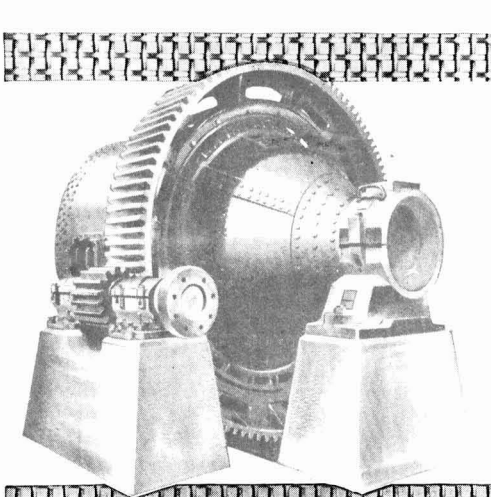

* IC processing plant is helping to improve chemical output all over the world

Here are four typical machines—the Hardinge Mill, Vaeseal Pump, Rovac Filter and Tyrock Screen—from the IC range of processing plant which also includes pulverisers, separators, classifiers, thickeners, and laboratory equipment. With any basic material . . . for any industry . . . you can depend on IC equipment.

ENTERPRISING ENGINEERING by
INTERNATIONAL COMBUSTION PRODUCTS LTD.

London Office: Nineteen Woburn Place, W.C.1.

Telephone: Terminus 2833.

Works: Derby, England.

first line of defence against corrosives

The increasing use of chemicals in modern industrial processes makes it more than ever important to protect expensive plant from every sort of corrosive and abrasive attack. Dunclad linings provide the surest protection against these. Available in soft or hard rubber and in Butyl, P.V.C. and Neoprene to meet various service conditions, they can be installed with the full co-operation of the Dunclad Lining Service. Installation can be carried out either on site or in the Dunlop factory at Manchester.

Technicians with unrivalled experience and resources will willingly advise on any problem, or give whatever information you require :— just write to any of the addresses below.

*If your problem is with
corrosion, your need is for*

DUNCLAD

CHEMICAL PLANT LININGS by DUNLOP

Head Office and Factory :

DUNLOP RUBBER COMPANY LIMITED (G R.G. DIVISION), CAMBRIDGE STREET, MANCHESTER.

South: CLERKENWELL HOUSE, CLERKENWELL GREEN, LONDON, E.C.1.

Midlands: DUNLOP HOUSE, LIVERY STREET, BIRMINGHAM 3.

North: 57 MEADOW ROAD, LEEDS 11.

Scotland: DUNLOP RUBBER CO. (SCOTLAND) LTD., NORTH WALLACE STREET, GLASGOW C.4.

INDEX TO ADVERTISERS

The first figures refer to advertisement in Chemical Age Year Book, the second to the current issue

Page	Page	Page	Page	Page	Page
229	A.P.V. Co., Ltd., The	227	British Steam Specialties Ltd.	174	Dring & Fage Ltd.
344	Acalor (1948) Ltd.	168	British Tar Products Ltd.	174	Drummond Patents Ltd.
209	Accrington Brick & Tile Co., Ltd., The	231	Brotherhood, Peter, Ltd.	195	Dryden, T., Ltd.
176	Adequate Weighers Ltd.	170	British Titan Products Co., Ltd.	—	Dunlop Rubber Co. Ltd.
223	Aero Research Ltd.	397	Broadbent, Thomas, & Sons, Ltd.	525	Dutt, P. K., & Co., Ltd.
223	Aimer Products Ltd.	231	Brotherhood, Peter, Ltd.	570	E.C.D., Ltd.
159	Albany Engineering Co. Ltd. The	244	Brotherton & Co., Ltd.	232	E.C.D., Ltd.
—	Alexander, Herbert, & Co., Ltd.	238	Brough, E. A., & Co., Ltd.	330	Edison Swan Electric Co., Ltd., The
—	Alginate Industries Ltd.	214	Browns Foundry Co., Ltd.	268	Electronic Switchgear (London) Ltd.
165	Allen, Edgar, & Co., Ltd.	234	Brush Design Group, The	—	244 Electrothermal Engineering Ltd.
364	Alumina Co., Ltd., The	175	Bryan Donkin Co., Ltd., The	568	B/Mk. Elliott, H. J., Ltd.
328	Amalgamated Oxides (1939) Ltd.	180	Buell (1952) Ltd.	—	Enamelled Metal Products Ltd.
306	Armour & Co., Ltd.	272	Burnett & Rolfe Ltd.	166	English Glass Co., Ltd., The
G/Cd.	Ashmore, Benson, Pease & Co.	—	Buss & Co.	G/Cd.	Erinoid Ltd.
189	Ashworth, Arthur, Ltd.	—	Butterworths Scientific Publications	—	Evans, Norman, & Rais, Ltd.
—	Associated Lead Mfrs. Ltd.	201	Butterfield, W. P., Ltd.	532	Evered & Co., Ltd.
G/Cd.	Audley Engineering Co., Ltd.	160	Calder Vale Glassworks Ltd.	—	Ewart, M. D., & Co., Ltd.
146	Autometric Pumps Ltd.	—	Callow, F. E. (Engineers) Ltd.	208	Farnell Carbons Ltd.
212	B. A. Holland Engineering Co., Ltd., The	354	Callow Rock Lime Co. Ltd. The	—	Fawcett Finney Ltd.
—	B.X. Plastics Ltd.	—	Candy Filter Co., Ltd., The	202	Ferris, J. & E., Ltd.
282	Baker Perkins Ltd.	238	Cannon (G. A.) Ltd.	—	Fleischmann (London) Ltd.
324	Baker Platinum Division, Engelhard Industries Ltd.	280	Carbon Dioxide Co., The	220	Film Cooling Towers (1925) Ltd.
233	Balfour, Henry, & Co.	243	Carmichael, John R., Ltd.	253	Foxboro-Yoxall Ltd.
210	Barclay Kellett & Co., Ltd.	—	Catalin Ltd.	—	Fraser, W. J., & Co., Ltd.
250	Bennett, Sons & Shears Ltd.	—	Chapman & Hall Ltd.	298	Fuller's Earth Union Ltd., The
G/Cd.	Berk, F. W., & Co., Ltd.	528	Chemical Construction Co.	188	Gallenkamp, A., & Co., Ltd.
242	Beryllium & Copper Alloys (Safety Tools) Ltd.	531	Chemical Workers' Union, The	—	Garcia, S., Ltd.
—	Bivac Air Co. Ltd.	572	Chemicals & Feeds Ltd.	566	Geigy Co., Ltd., The
270	Black, B., & Son, Ltd.	—	Chemitrade Ltd.	266	Geigy Pharmaceutical Co., Ltd.
204	Blundell & Crompton Ltd.	284	Chesterfield Tube Co., Ltd., The	—	General Electric Co., Ltd.
148	Borax Consolidated Ltd.	203	Ciech Ltd.	—	Glebe Mines Limited
—	Borax & Chemicals Ltd.	264	Cinema Television Ltd.	—	Graesser, R., Ltd.
289	Boulton, William, Ltd.	224	Clark, T. C., & Co., Ltd.	570	Graviner Mfg. Co. Ltd.
228	Bowmans Chemicals Ltd.	258	Classified Advertisements 574,575,576	265	Grzebrook, M. & W., Ltd.
270	Braby, Fredk., & Co., Ltd.	199	Clayton Dyestuffs Co. Ltd. The	164	Greeff, R. W., & Co., Ltd.
183	Bramigk & Co., Ltd.	—	Clayton, Son & Co., Ltd.	192	Grindley & Co., Ltd.
—	British Acheson Electrodes Ltd.	285	Clydesdale Chemical Co. Ltd.	232	Hackbridge & Hewittic Electric Co., Ltd.
224	British Arca Regulators Ltd.	213	Clyde Tube Forgings Ltd.	—	202 Haller & Phillips Ltd.
217	British Carbo Norit Union Ltd.	208	Cole, R. H., & Co., Ltd.	573	214 Hanovia Lamps
—	British Ceca Co., Ltd., The	204	Cole & Wilson Ltd.	—	Hanovia Books
216	British Chrome & Chemicals Ltd. (London)	348	Collins Improved Firebars Ltd.	560	206 Harris (Lostock Gramal) Ltd.
230	British Chrome & Chemicals Ltd. (Lancs)	—	Comet Pump & Eng. Co. Ltd. The	222	Haworth, F. (A.R.C.) Ltd.
—	British Drug Houses Ltd., The	171	Constable & Co.	158	Hearson, Charles, & Co., Ltd.
—	British Electrical Development Association	374	Controlled Convection Drying Co.	238	Herbert, Alfred, Ltd.
—	British Geon Limited	170	Costain-John Brown Ltd.	566	Holden, Chris., Ltd.
8	British Industrial Solvents	216	Crofts (Engineers) Ltd.	—	Holmes, W. C., & Co., Ltd.
236 & 237	British Laboratory Ware Association Ltd.	—	Cromil & Piercy Ltd.	193	Holroyd, John, & Co., Ltd.
275	British LaBour Pump Co., Ltd.	304	Cruickshank, R., Ltd.	234	Honeywill & Stein Ltd.
240	British Lead Mills Ltd.	222	Curran, Edward, Engineering Ltd.	248	Hopkin & Williams Ltd.
360	British Railway Traffic & Electric Co., Ltd.	288	Cyanamid Products Ltd.	187	Humphreys & Glasgow Ltd.
Spine	British Resin Products Ltd.	286	Cyclops Engineering Co. Ltd. The	310	Huntington, Heberlein & Co. Ltd.
172	British Rototherm Co. Ltd. The	216	Cygnat Joinery Ltd.	—	I.C.I. Billingham Organic
—	—	—	Danks of Netherton Ltd.	—	I.C.I. General Chemicals Florube
—	—	170	Davey, Paxman & Co., Ltd.	—	I.C.I. Plastics—Darvic
—	—	161	Dawson, McDonald & Dawson Ltd.	—	I.C.I. Plastics—Fluon.
—	—	280	Dechma	157	Imperial Chemical Industries Ltd.
—	—	200	Derby Luminescents Ltd.	—	Imperial Smelting Corporation (Sales) Ltd.
—	—	—	Dorr-Oliver Co., Ltd.	—	—
—	—	—	Douglas, William, & Sons Ltd.	—	—
—	—	—	Dowlow Lime & Stone Co., Ltd., The	—	—

[continued on page 528]

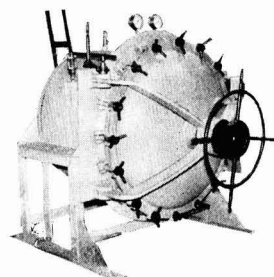

PRESSURE VESSELS

IN STEEL
STAINLESS STEEL
ALUMINIUM
COPPER · ETC.

Welded by the Argon Arc Process

METAL SPRAYING
WELDING AND REPAIRS
TO ALL METALS

RICHMOND WELDING CO.

EST. 1929

RICHMOND RD. · BRADFORD · 7 · Tel: 25405

"ZULO"

CARBOY HAMPERS

LEIGH & SONS
METAL WORKS
Orlando LTD.
St., BOLTON

CARBOYS · PACKED CARBOYS
 CARBOY FILTERS AND BARROWS
 SAFETY CRATES TOP PROTECTORS

murgatroyd's

offer the following product for immediate delivery

Liquid Caustic Soda

(IN TANKS AND DRUMS)

Full details can be obtained from the Sole Selling Agents and Area Distributors

LONDON, SOUTH OF ENGLAND AND MIDLANDS
Barter Trading Corporation Ltd., 14 Waterloo Place, London, S.W.1.

NORTH OF ENGLAND
Tennants (Lancashire) Ltd., 1 Booth Street, Manchester, 2.

SCOTLAND
Charles Tennant & Co. Ltd., Glenconnor Works, North Hillington, Glasgow, S.W.2

NORTHERN IRELAND
Charles Tennant & Co. (N.I.) Ltd., 94 Royal Avenue, Belfast.

EIRE
Charles Tennant & Co. (Eire) Ltd., 1, 2, 3, Westmorland Street, Dublin.



MURGATROYD'S SALT AND CHEMICAL COMPANY LIMITED
ELWORTH, SANDBACH, CHESHIRE

FINE CITRIC ACID IN THE MAKING



Running a Temperature

No use telling our new artist that pictures are a primitive form of expression which gave way to symbols, alphabets and written language. Just mention a phrase and he makes a visual interpretation of it — usually the wrong one. The high temperature we had in mind gives no cause for alarm, but it is in fact essential at a certain stage in the production of Sturge citric acid. It occurs when spores of *Aspergillus Niger* are sown in molasses.

As the spores feed on the raw material and form a mould, considerable heat is generated. After several days, when the conversion to acid is complete, the solution undergoes several stages of refining before emerging as the pure citric acid for which Sturge is famous throughout the world.

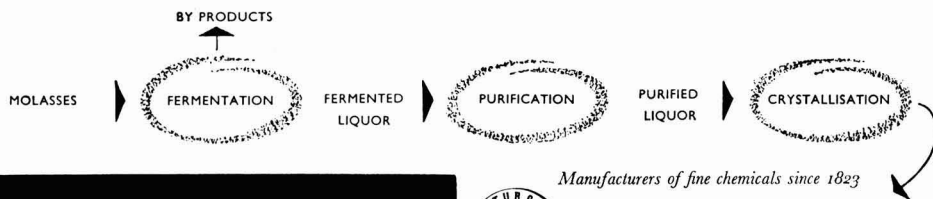

STURGE



Manufacturers of fine chemicals since 1823

CITRIC ACID BP

CITRIC ACID ANHYDROUS

JOHN & E. STURGE LTD • WHEELYS ROAD • BIRMINGHAM, 15 • TEL: MIDLAND 1236

TGA CAP

"OIL FREE" COMPRESSORS & VACUUM PUMPS

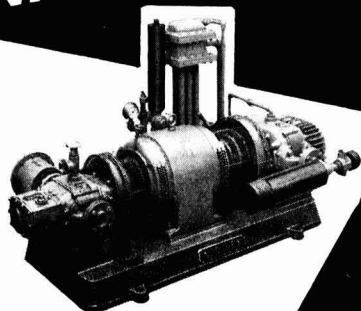

Type 162/102 TCWD 2 stage water-cooled "Oil Free" Compressor. 28 c.f.m. of free air delivered at 60 lb./sq. in.

Due to the unique design features of Northey Positive Rotary Compressors and Vacuum Pumps, there is a complete absence of frictional contact. No oil is necessary in the compression chamber, so that the air is delivered free from oil and oil vapour.

For details of this highly successful and widely used equipment write to:

Northey

ROTARY COMPRESSORS LTD.

**ALDER ROAD PARKSTONE
POOLE DORSET**

**TELEPHONE PARKSTONE 4900
(2 LINES)**

ELIMINATE YOUR BOTTOM BEARINGS

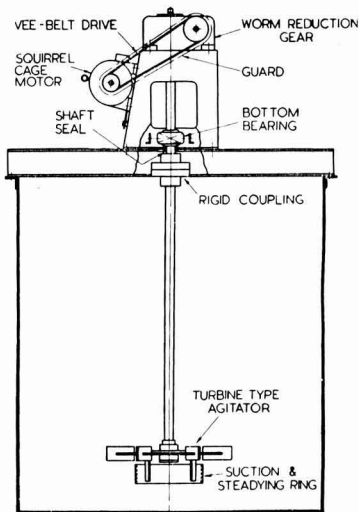

BY USING THE "STOCKDALE" TURBO AGITATOR

The specially designed Agitator by virtue of its inherent design entirely eliminates the need for the trouble-causing bottom bearing. Our Development Department will advise you on designs.

STOCKDALE

ENGINEERING LIMITED

LONDON ROAD SOUTH · POYNTON · CHESHIRE

Telephone poynton 2601/2

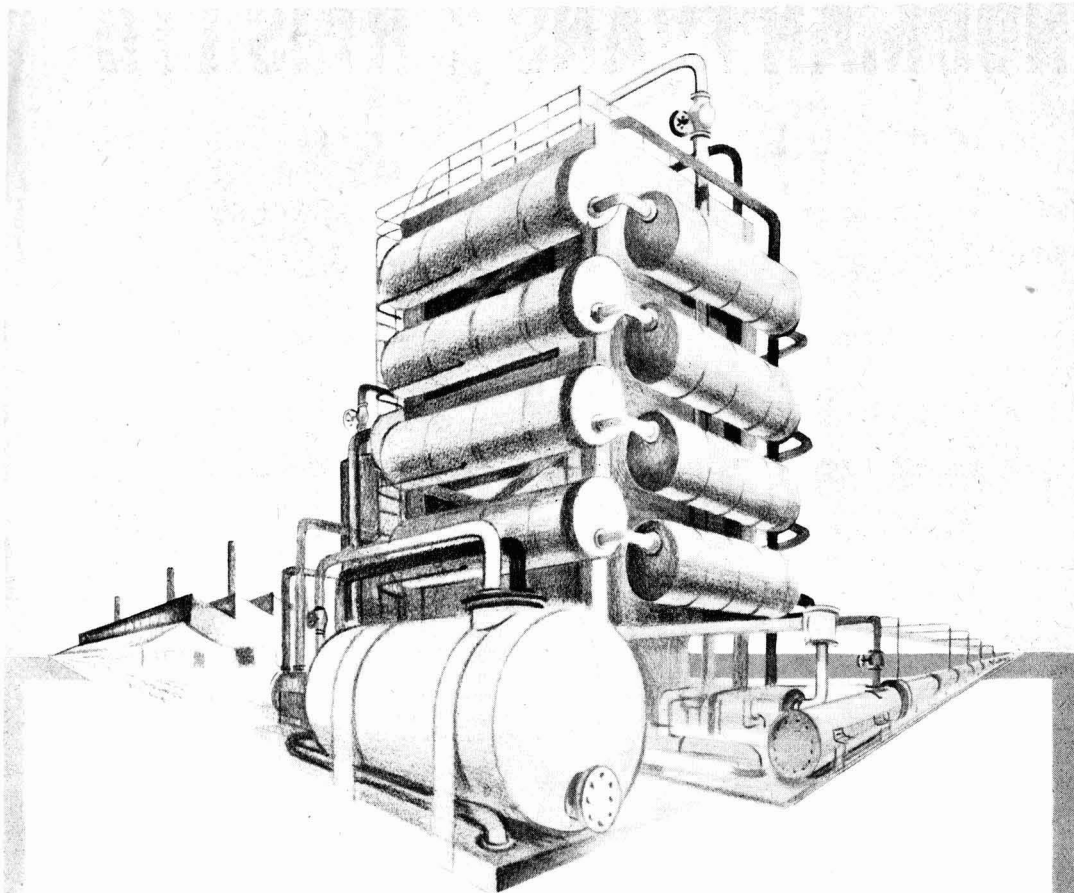

New Chemical Plant

Chemical Construction (Great Britain) Ltd, specialise in the entire planning, design, procurement and erection of chemical plant for:

AMMONIA SYNTHESIS · SULPHURIC ACID
NITRIC ACID · AMMONIUM SULPHATE
AMMONIUM NITRATE · UREA, ETC.

In these activities the Company operates in close collaboration with its American associate—Chemical Construction Corporation, New York, and the resources of the two organisations are always at the service of the chemical industry.

CHEMICAL CONSTRUCTION (GREAT BRITAIN) LTD
(Subsidiary of Electric Bond and Share Company, New York)

BUSH HOUSE · ALDWYCH · LONDON W.C.2

NORMAN EVANS & RAIS LTD

MANUFACTURERS OF: Enzymes for all purposes • Metal Sequestering Agents • Sulphated Fatty Alcohols Detergents • Shampoo bases • all types Surface Active Agents • Poly Ethylene Glycol Esters • Cutting oils • Disinfectants • Naphthenates • Ethyl Hexoates Linoleates • Oleates and Stearates, etc. etc. for the Textile, Laundry, Paint, Varnish, Lacquer, Linoleum, Adhesive, Food, Fruit Juices, Leather, Paper, Chemical and all other industries.

NORMAN EVANS & RAIS LTD., UNITY MILLS, POLEACRE LANE, WOODLEY, STOCKPORT, CHESHIRE

TELEPHONE : WOODLEY 2277 (4 lines).

TELEGRAMS & CABLES : CHRIVAN, STOCKPORT.

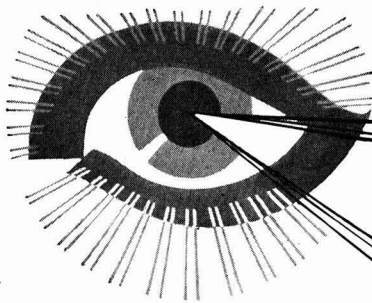

Look-no GLANDS!!

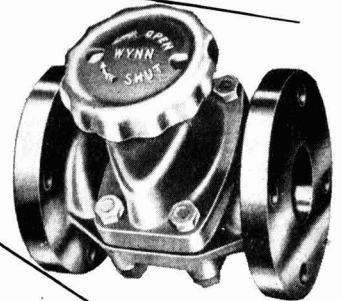

WYNN PATENT STRAIGHT-THROUGH DIAPHRAGM VALVES are glandless and have full, uninterrupted flow with wide seat, short lift diaphragm. Made in sizes $\frac{1}{2}$ " to 14" in Cast Iron (lined and unlined), Stainless Steel, Aluminium, Acid Resisting Bronze, etc.

WYNN PATENT STRAIGHT-THROUGH DIAPHRAGM VALVES are ideal for corrosives, abrasives and all 'hard-to-handle' fluids.



STRAIGHT THROUGH

WRITE FOR TECHNICAL BULLETIN D.3

WYNN (VALVES) LTD.

GRANVILLE STREET, BIRMINGHAM, 1

Agents & Stockists for Lancashire & Cheshire: Metallic construction Co. (Manchester) Ltd., 133 Withington Rd., Manchester 16. Tel.: Moss-side 1306

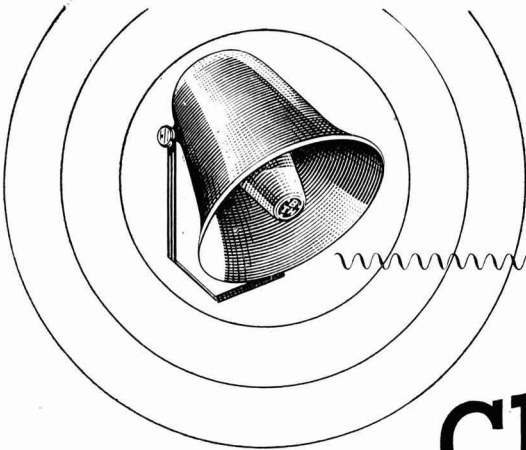

~~~~~ CLEAR AS A BELL ~~~~~

# CLEARCALL

## Industrial Communication System

With "Clearcall", speech can be clearly heard through the din of a noisy factory, or it can be adjusted for quiet surroundings.

"Clearcall" components are of rugged industrial design, and will not fail in spite of dirt, damp, and rough usage.

The equipment is suitable for iron and steel works, rolling mills, etc., paint and varnish factories, chemical works.

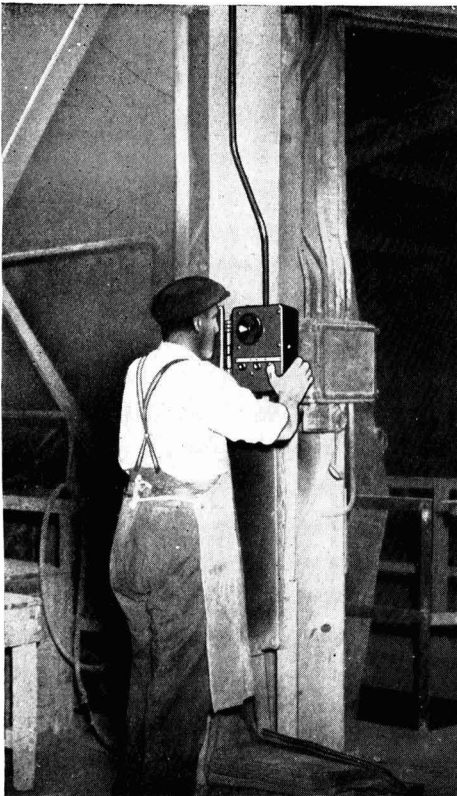

### SAFE!

"Clearcall" components are the subject of an "intrinsic safety certificate" in respect of Pentane Vapour etc. Details on application.



THE **BRITISH THOMSON-HOUSTON**

COMPANY LIMITED, RUGBY, ENGLAND

A 4582

an A.E.I. Company

# CHEMICAL UNLOADING SIMPLIFIED

*Powders Collected, Conveyed  
Filtered and Reloaded in  
ONE OPERATION . . .*

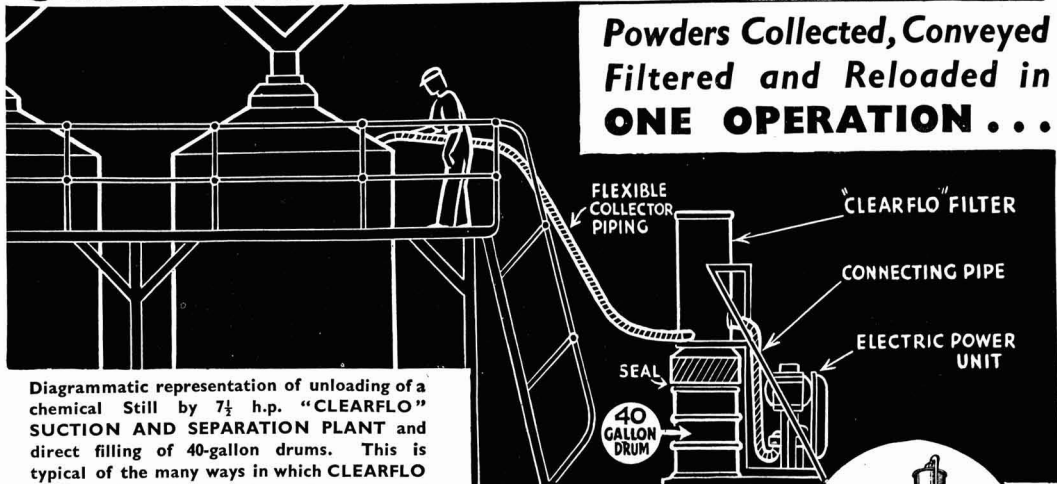

Diagrammatic representation of unloading of a chemical Still by  $7\frac{1}{2}$  h.p. "CLEARFLO" SUCTION AND SEPARATION PLANT and direct filling of 40-gallon drums. This is typical of the many ways in which CLEARFLO Equipment can be used in modern chemical processes.

Your enquiries are invited

(On right) 15 h.p. Standard CLEARFLO Pneumatic Conveying Unit.

## BIVAC AIR COMPANY LTD

PORTWOOD, STOCKPORT, CHES. Tel: STockport 4610



*Metafilters secure the complete removal  
of suspended matter from any liquid  
at any temperature and pressure, giving an*

### OPTICALLY CLEAR FILTRATE

*without oxidation, loss of solvent, or escape  
of fumes. Can be completely cleaned in a few minutes  
without opening up. Constructed without  
soldering, brazing, or welding.*

A TYPICAL  
**METAFILTER**  
INSTALLATION

*Sizes from 10 gallons to 10,000  
gallons per hour in any metal.*

**THE METAFILTRATION COMPANY LIMITED**  
BELGRAVE ROAD HOUNSLOW MIDDLESEX  
Phone: Hounslow 1121-2-3 Grams: Metafilter Hounslow

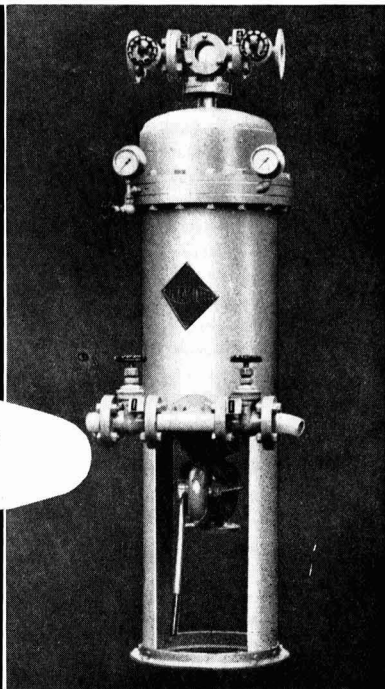

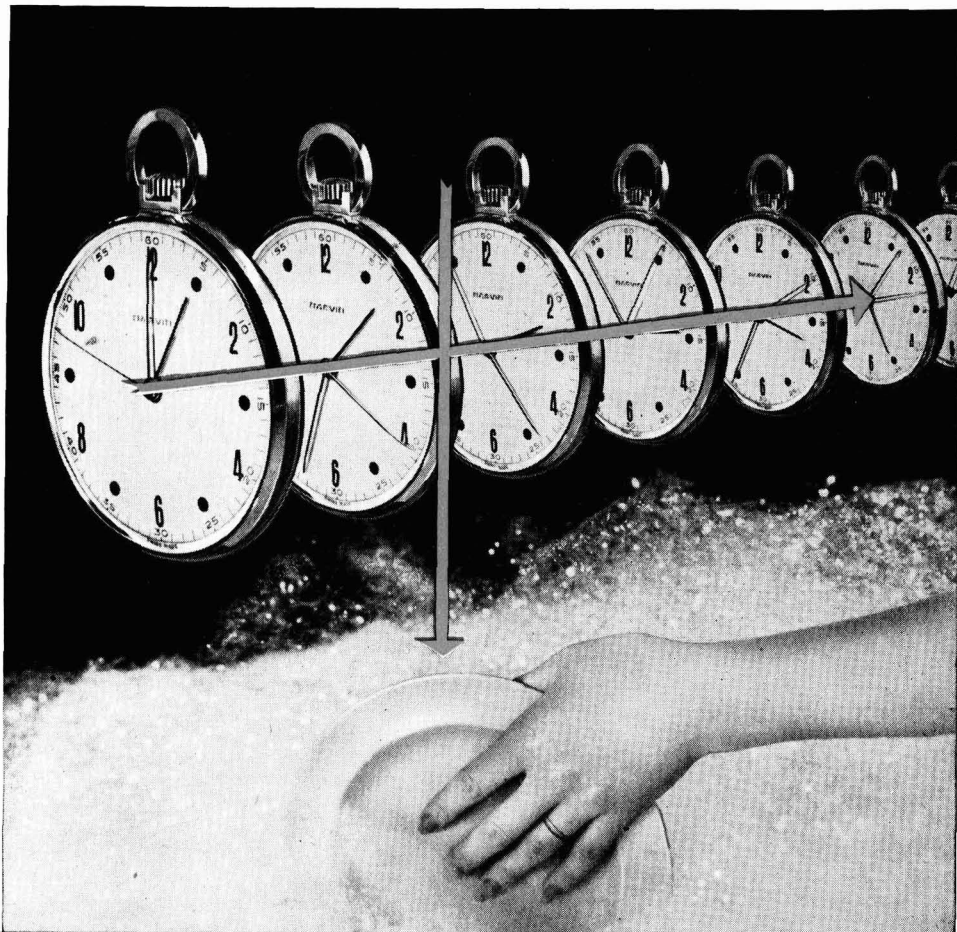

## ***FOAMING ACTION...lasts through the active life of the detergent***

Marchon Detergent Additives boost detergent foaming power to yield sparkling, stable foams that can be balanced to last exactly to the end of the detergent life. Gearing foaming action to detergent life ensures the maximum economy to the user. *Foam Boosting means Sales Boosting.*

### **MARCHON DETERGENT ADDITIVES**

**Empilan Series.** Narrow cut and broad cut isopropanol-amides, Ethanolamides and their derivatives.

**Ninol Series.** Alkylolamides made under licence from Ninol Laboratories Inc., Chicago.

### **MARCHON PRODUCTS LIMITED**

Agents and Offices in principal cities of the world

Head Office: Whitehaven, England Telephone: Whitehaven 650 Telegrams: Marchonpro, Whitehaven, Telex  
London Office: 140 Park Lane, London, W.1 Telephone: Mayfair 7385 Telegrams: Marchonpro, London, Telex

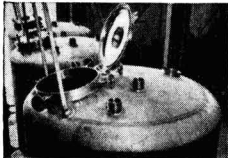
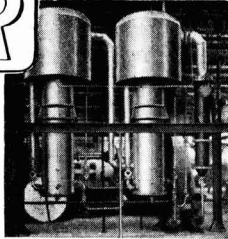

... DESIGN  
 ... PERFORMANCE  
 ... QUALITY

*FABRICATION*  
 in Stainless Steel  
 Aluminium  
 Monel Metal  
 Copper, etc.

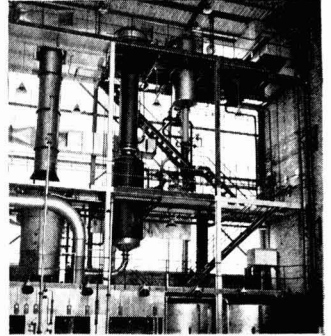

### PROCESS PLANTS

EVAPORATION  
 FORMALDEHYDE  
 ALKYD RESINS  
 ESTER GUMS  
 STAND OIL  
 DISTILLATION  
 SOLVENT RECOVERY, etc.

**BURNETT & ROLFE LTD., THE ESPLANADE, ROCHESTER, KENT**

Telephone : CHATHAM 3861

Telegrams : FULLYQUIP, ROCHESTER

Northern Representative : D. S. CHADWICK, 32 DEANS GATE, MANCHESTER. BLACKFRIARS 3851

**LAPORTE CHEMICALS**  
 FOR

*industry*

### HYDROGEN PEROXIDE

SODIUM PERBORATE  
 ORGANIC PEROXY  
 COMPOUNDS  
 BARIUM COMPOUNDS  
 SODIUM SULPHIDE  
 DETERGENTS



**LAPORTE**

Laporte Chemicals Ltd., Luton.

Telephone : Luton 4390. Telegrams : Laporte, Luton.

*All over the World...*

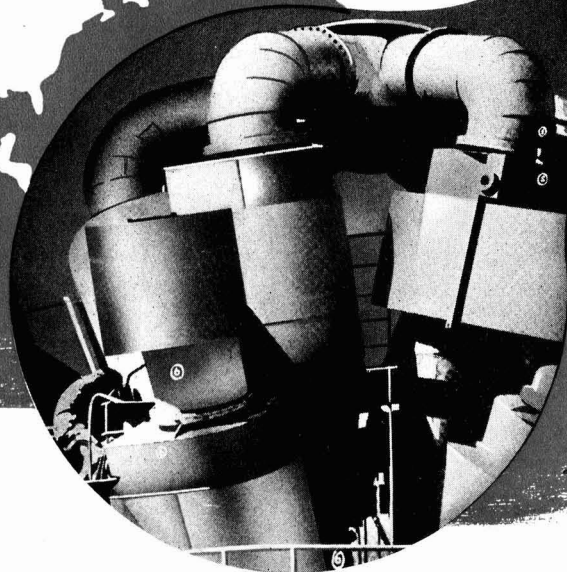

# HYDROFLUORIC ACIDS and FLUORIDES . . .

*from the No. 1 producer  
of the United Kingdom  
and the Commonwealth*



**INDUSTRIAL  
WILKINSON  
CHEMICALS**

JAMES WILKINSON & SON LTD., TINSLEY PARK ROAD, SHEFFIELD 9  
Telephone: 41208/9 *Grams: 'Chemicals' Sheffield 9*

# EXCITING PROMISE OF DRY POWDER FULFILLED BY NU-SWIFT!

## HOW NU-SWIFT DRY POWDER KILLS DANGEROUS FIRES

Released from a sealed pressure charge, the finely ground powder bursts out in a fan-shaped cloud, smothering and blanketing the fire. The fine cloud also gives the fire fighter complete protection against the intense heat of a liquid fire, allowing him to get within effective range of the blaze.

## DRAWBACKS HITHERTO ASSOCIATED WITH DRY POWDER PRINCIPLE NOW ELIMINATED

**WE MAKE OUR OWN POWDER** It is carefully prepared, ground, sieved, and mixed in our own £30,000 powder mill. Special treatment during manufacturing process avoids any chance of coagulation through static electricity.

No ingredients liable to bacteriological decay are used in its manufacture.

**EFFICIENT EXTINGUISHER DESIGN** Nu-Swift dry powder is held in sealed pressure charges—so it cannot cake, pack, or coagulate because of humidity.

Only negligible maintenance is necessary: inspection is simple—the tell-tale gauge on the container indicates whether the charge is unused and under pressure.

**NU-SWIFT DRY POWDER IS NON-TOXIC;  
NON-CONDUCTIVE; NON-CORROSIVE; NON-ABRASIVE;  
AND FROST-PROOF DOWN TO -40°C.**

**EXTINGUISHER MODEL 1604: £10.10.0.**

FOC Ref. No. 104/8. Spare charges (No. 64) 95/-

**SEND OR PHONE FOR BOOKLET No. 364**—better still, mail your order—and see for yourself!

# NU-SWIFT

THE WORLD'S FASTEST AND MOST RELIABLE  
FIRE FIGHTING EQUIPMENT

NU-SWIFT LTD., 25 PICCADILLY, LONDON, W.1. Tel: REGent 5724  
FACTORY & HEAD OFFICE: ELLAND, YORKSHIRE. Tel: Elland 2852

To Nu-Swift Ltd., Dept. C.A., 25 Piccadilly, London, W.1.  
Please let me have your Dry Powder extinguisher booklet No. 364

NAME \_\_\_\_\_

ADDRESS \_\_\_\_\_



## THE NU-SWIFT DRY POWDER EXTINGUISHER MODEL 1604

*Astounding new Dry Powder  
extinguisher which kills these  
fires IN SECONDS:*

### CLASS 'B' FIRES

\*All accessible inflammable liquid fires, including alcohol, petrol, organic solvents of every kind, oils and asphalts.

### CLASS 'C' FIRES

\*All electrical fires, and fires in motor vehicles, electronic equipment, etc.



VOL. 77

No. 1968

30 MARCH 1957

Telephone: FLEet Street 3212 (26 lines)

Telegrams: Allangas . Fleet . London

Editor *Manager*  
M. C. HYDE H. A. WILLMOTT

Director N. B. LIVINGSTONE WALLACE

**Midlands Office**

Daimler House, Paradise Street,  
Birmingham. [Midland 0784-5]

**Leeds Office**

Martins Bank Chambers, Park Row,  
Leeds 1. [Leeds 22601]

**Scottish Office**

116 Hope Street, Glasgow, C2.  
[Central 3954-5]

**IN THIS ISSUE**

|                                 |     |
|---------------------------------|-----|
| Natural v Synthetic Rubber      | 540 |
| Hydrocarbon Nomenclature        | 540 |
| Lancashire and Cheshire Section |     |
| Foreword by T. C. Fawcett       | 541 |
| Chemical Producing Centres      | 542 |
| Plants, Products and Projects   | 543 |
| Chemical Industry Surveyed      | 546 |
| Chemical Engineering            | 549 |
| Royal Charter for I.Chem.E.     | 553 |
| Correspondence                  | 553 |
| Brotherton Reorganisation       | 554 |
| Polish Sulphur Developments     | 554 |
| Anglo-US Research Link          | 555 |
| NRDC Report                     | 556 |
| Overseas News                   | 557 |
| Rubber Symposium Opened         | 559 |
| Chemist's Bookshelf             | 560 |
| People in the News              | 561 |
| Commercial News                 | 562 |
| Market Reports                  | 562 |
| New Patents                     | 563 |
| Current Prices                  | 564 |
| Chemical Stocks and Shares      | 565 |
| For Your Diary                  | 566 |

Annual subscription is 52s 6d (\$7.40),  
single copies 1s 3d (by post 1s 6d).

# CHEMICAL AGE

BOUVERIE HOUSE • 154 FLEET STREET • LONDON • EC4

## BOC'S ANSWER

THE MUCH AWAITED reply from the British Oxygen Company to the Monopolies Commission's report on the company. (see CHEMICAL AGE, 19 January) has now been published in booklet form and circulated to BOC customers, shareholders and employees.

BOC chairman, Mr. J. S. Hutchinson, announces in this booklet that British Oxygen is to apply at once some of the recommendations of the Monopolies Commission, but that the company could not agree with a majority view that its profits were 'unjustifiably high.'

Profits and research are described in the booklet as two 'debatable issues' between the Commission and the company. 'The fact that the Commission is divided on the question of profits shows at once how hard it is to agree to profit rates,' it states. In their reply BOC claim that it is not sufficiently recognised that oxygen and acetylene are in sharp competition with electrical welding processes and with mechanical processes. 'Their development rests entirely on their being presented in an economical and efficient way to the customer.'

A policy of rapid extension of use through low selling prices, maximum efficiency and moderate unit profit had been followed by the company. Rapid expansion, post-war constructional difficulties and the inflationary spiral had made regulation of profit difficult.

The Commission had advanced the proposition that BOC's monopoly position in certain gases absolved it from a certain degree of commercial risk, enabling it, as a result, to raise capital on favourable terms. This, BOC state, is not tenable as ability to raise capital depends on meeting competition in the market from other concerns of similar stature. Also the company must remain in a position to attract capital, as it required £18 million in little over a year and it will need more to maintain and develop its activity. 'This necessary capital cannot be obtained in the competitive capital market from a basis of inferior profits.' BOC maintain that profit should be related to replacement cost, and not historical cost of assets. On the replacement basis actual profits were 16 per cent in 1955 and 15 per cent in 1956.

In reply to the Commission's statement regarding adequacy of research activities by BOC, the company says expenditure has risen steadily in recent years, reaching £700,000 in 1956, which represented 2.8 per cent of total sales. Mention is made in the booklet of the company's tonnage oxygen process, the industrial liquid oxygen plants, of completion shortly of pipeline distribution projects, and of vigorous research in user equipment, welding, fundamental work on properties of gases and basic operations such as distillation, compression and heat transfer.

'Licence agreements are regarded as a supplement to and not a substitute for research and are important aids to progress,' BOC claim. It also makes the point that collaboration with others in this and other ways offers a proper rationalisation of work in particular fields on a reciprocal basis with important savings in time and in precious technical manpower.

The company accepts the Commission's view that the use of 'fighting companies' should cease on the question of control over the sale of plant. BOC state that its plant-building resources are at the disposal of all who

wish to purchase a private plant. Contract terms demanding exclusive purchase of gas from BOC will be dropped and the company is ready to publish new scales of prices, for which purpose it is going to call in professional advice for a new analysis of individual costs.

Thus, BOC have responded quickly to the Commission's recommendations. According to the chairman, the company has welcomed the recent criticism by the Monopolies Commission and it has shown by deed that it agrees with many of its recommendations. Other points are still under discussion with the Board of Trade and a further statement will be made when these talks are concluded.

In their defence, BOC have suggested that the Commission has taken a narrow view and failed to realise the problems involved in raising capital for a business with widely based and varied activities.

One of the most interesting features of BOC's annual report is a calculation of the return on the average capital employed. This is based on a comparison of the results of the past decade and it shows that in 1947 the return was 20.5 per cent, in 1948, 23.5 per cent, but in the following two years it had dropped to 17.5 per cent and fell to 16 per cent in 1951. It rose slightly to 16.5 per cent in 1952 but fell to 15.5 per cent in 1953. For 1954 the return was again 16.5 per cent, but it dropped to 15 per cent in 1955 and to 14 per cent last year, even though record profits were earned.

'In the face of these figures,' states the *Investors' Guardian*, 'it is difficult to understand the Commission's attitude. Fourteen per cent must be regarded as a modest return in comparison with the earnings of some other industries.'

A business must operate on a reasonable margin of profit if it is to function efficiently and make progress. However, present high taxation is making it even more difficult to retain sufficient funds to finance essential development and expand trade.

BOC are to be commended for the spirit in which they have accepted the report and the criticisms made of their structural operating arrangements.

## NATURAL v SYNTHETIC RUBBER

**T**HIS WEEK, the International Synthetic Rubber Symposium was held in London. It can be considered to mark yet another stage in the development of the rubber industry in the UK and Europe.

Until recently, Europe has been almost entirely dependent on supplies of synthetic rubber from the US, although Germany has produced just over 10,000 tons annually since 1954 (1 per cent of total world output). Now, to meet the growing demand for rubber, new plants have been, and are being, set up in the UK, Germany, France and Italy. UK plants by the end of this year will have an annual capacity of over 12,000 tons and in 1958, the 50,000-ton general purpose synthetic rubber plant at Fawley will be operating. In this same year, Germany will have a 45,000-ton plant in operation (that of Chemische Werke Hüls AG). Large scale production of synthetic rubber is also planned in France and Italy.

Western Europe is expected to produce about 160,000 long tons of synthetic rubber this year and up to 250,000 tons by 1958, while estimations of 1957 US capacity put the figure at 1,645,000 long tons. By 1960 it is predicted, some 3,590,000 long tons will be required by countries outside the Iron Curtain.

Natural rubber production now amounts to 1.9 million tons a year, but no great rise in the present output is foreseen. Consumption of both natural and synthetic rubber is, however, increasing and the gap between natural and synthetic material must be filled by the synthetic. In fact, such has been the emphasis placed on synthetic rubber development that talk of 'war' between natural and synthetic

rubber has been heard. It has even been advocated that natural rubber producers should try and undersell the man-made product.

The retiring chairman of the Singapore Chamber of Commerce Rubber Association, Mr. E. G. Holiday, speaking at the association's annual meeting on 25 March, declared that 'there is no cut-throat competition. Both industries are essential to world economy.' This view was also emphasised by the symposium chairman, Mr. Beharrel, in his opening address (see p. 559). Synthetic rubber is not simply a substitute for the natural product.

It is recognised that for many uses the natural rubber is the better product. Active research into the synthesis of the natural rubber molecule is well under way, and indeed in the US there is now pilot plant production of 'natural' synthetics by Goodrich-Gulf-Chemicals and Firestone. One particular 'natural' synthetic produced by the company is Ameripol SN, which was the subject of a paper presented at the symposium. It is claimed that this synthetic is a potential replacement for all or part of the natural rubber in heavy duty tyres.

Tyres have until recently taken the great proportion of natural rubber (about 61 per cent), but this is decreasing, although non-tyre demands have increased. Synthetics, however, have been making spectacular gains. Undoubtedly continued efforts are necessary to improve quality and maintain high standards in the selection of grades in natural rubber and in packing. Also if possible, stabilisation of the natural rubber prices should assist this industry.

## HYDROCARBON NOMENCLATURE

**U**NANIMOUS APPROVAL has been given by the Nomenclature Committee of the American Chemical Society's Division of Petroleum Chemistry of a draft statement on the nomenclature of hydrocarbon classes. (*Chem. & Engng. News*, 1957, 35, No. 8, 72). Definition of the various classes is as follows:

**Hydrocarbons**—compounds containing only hydrogen and carbon.

**Saturated hydrocarbons**—hydrocarbons with carbon atoms joined by single bonds and in which the unshared carbon valences are fully saturated with hydrogen.

**Unsaturated hydrocarbons**—those hydrocarbons in which two or more carbon atoms are joined by bonds other than single bonds.

**Paraffinic hydrocarbons (alkanes, paraffins)**—saturated open chain hydrocarbons with type formula,  $C_n H_{2n+2}$ .

**Naphthenic hydrocarbons (naphthenes, cyclo-alkanes, cycloparaffins)**—saturated hydrocarbons which contain at least one ring.

**Olefinic hydrocarbons (olefins, alkenes)**—unsaturated hydrocarbons containing at least one double bond which is not in an aromatic ring.

**Acetylenic hydrocarbons (acetylenes, alkynes)**—unsaturated hydrocarbons which contain at least one triple bond.

**Aromatic hydrocarbons (arenes)**—Unsaturated hydrocarbons which contain at least one benzene nucleus.

In usage the committee states that the terms 'saturates' and 'unsaturates' may be used as abbreviations for the longer terms 'saturated hydrocarbons' and 'unsaturated hydrocarbons.' Other abbreviations which may be used are—paraffins, naphthenes, olefins, acetylenes and aromatics.

It is of interest to note that the title 'arene' is to apply to all hydrocarbons containing at least one aromatic ring and is particularly recommended in naming derivatives such as alkyl arene sulphonates.

Nomenclature of hydrocarbons has been under consideration for some years in the US and it is now hoped that the Nomenclature Committee of the ACS will finalise its statement in order to avoid the divergence of usage of terms relating to groups of hydrocarbons.

# LANCASHIRE AND CHESHIRE

## A Special 'Chemical Age' Survey of Chemicals and Supplying Industries in the North West

### FOREWORD

By **T. C. FAWCETT**, *Chairman of the Chemicals and Allied Trades Section, Manchester Chamber of Commerce*



A YEAR AGO CHEMICAL AGE published a special article on the beginnings of the chemical industry in Lancashire and Cheshire, based on the alkali industry (Brunner Mond and United Alkali); the dyestuffs industry following Perkin's discovery of mauveine; the making of soap by Crosfields etc. From these small beginnings Lancashire and Cheshire have grown to be the greatest chemical producing area in the world. The accent is still on heavy chemicals, but the diversity is now enormous and ranges from inorganic chemicals of many types to chemicals based on petroleum—the most modern development, with its potentialities in the fields of plastics, solvents and plasticisers, oil additives and so on.

While chemical development schemes in Lancashire and Cheshire have slowed down somewhat in the last year or so, this is probably a natural consequence of the high rate of expansion between 1950/1955. However, investment has by no means ceased and developments over the past 12 months, and those planned for the future, cover such different products as ethylene oxide, hydrogen peroxide, liquid sulphur trioxide, chlorine and caustic soda, quaternary ammonium compounds, styrene monomer, and the plastics, polyvinyl chloride, polythene, and polytetrafluoroethylene.

Perhaps the most outstanding development in the area of recent years has been the creation of the United Sulphuric Acid Corporation, which is jointly owned by a number of firms (including Imperial Chemical Industries, Courtaulds, Fisons, Clayton Aniline and firms manufacturing artificial fibres and transparent paper) who recognised the need to make provision in advance for their own future requirements of sulphuric acid, and those of industry in general. Only a few years ago sulphuric acid was in short supply; now there is a surplus, which is probably only temporary, and supplies from existing plants are likely to be balanced by demand within the next few years. Acid made by USAC is interesting in that it is based on indigenous anhydrite and although the total amount of acid manufactured from this mineral is still a small proportion of the whole, it is felt that its use is a step in the right direction. Furthermore, the clinker from the kilns is sold to a cement manufacturer who has erected a works adjacent to the acid plant.

It is satisfactory to note that the industry has played its part in maintaining price levels during the past months, even when faced by the strain and dislocations following the closure of the Suez Canal.

In general, the industry is fairly confident of its capability to withstand competition from other European countries when the Free Trade Area is established, although doubtless some firms will suffer. However, the chemical industry is one of the most efficient in the country, due to its foresight and planning, the constant improvement of working conditions, and the extensive use of mechanisation and automation, and nowhere is this more true than in the counties of Lancashire and Cheshire. Apart from mechanisation in manufacture, developments in distribution—for example, bulk deliveries of hydrated lime and salt—are attracting attention with their tremendous advantages over earlier methods of handling.

A handwritten signature in dark ink, appearing to read 'T. C. Fawcett', with a horizontal line underneath.

# CHEMICAL PRODUCTION CENTRES IN THE NORTH-WEST

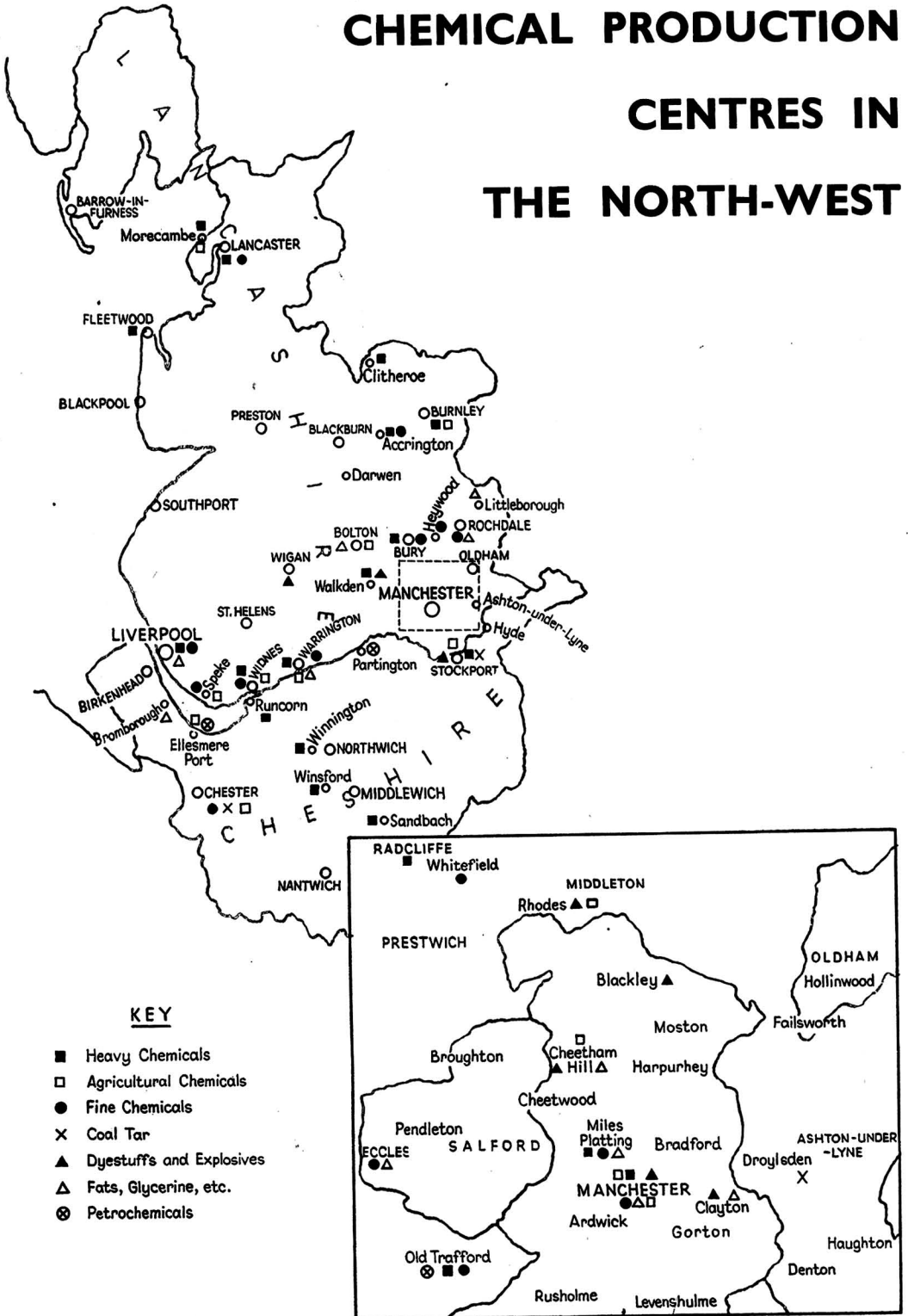

| COMPANY                                                                   | PLANT                                                                                           | MAIN PRODUCTS                                                                                                                                                                                                                                                                                                    | NEW PROJECTS                                                                                                    |
|---------------------------------------------------------------------------|-------------------------------------------------------------------------------------------------|------------------------------------------------------------------------------------------------------------------------------------------------------------------------------------------------------------------------------------------------------------------------------------------------------------------|-----------------------------------------------------------------------------------------------------------------|
| Albright & Wilson Ltd.,<br>45 Park Lane, London W1                        | Widnes<br>Kirkby, Liverpool                                                                     | Phosphorus, phosphoric acid, phosphates,<br>carbon tetrachloride<br>Sodium tripolyphosphate                                                                                                                                                                                                                      | —<br>Large area to be developed                                                                                 |
| Alumina Co. Ltd., The                                                     | Iron Bridge Works and<br>Ditton Road Works,<br>Widnes                                           | Aluminium sulphate                                                                                                                                                                                                                                                                                               | —                                                                                                               |
| Anchor Chemical Co. Ltd.                                                  | Clayton,<br>Manchester 11                                                                       | Chemicals for rubber, paint, printing ink,<br>oil and grease, and allied trades                                                                                                                                                                                                                                  | —                                                                                                               |
| Arthol Manufacturing Co.<br>Ltd.                                          | Sealand Road,<br>Chester                                                                        | Raw materials for the perfumery business<br>(W. J. Bush & Boake, Roberts)                                                                                                                                                                                                                                        | —                                                                                                               |
| Ashworth, Arthur, Ltd.                                                    | Fernhill Chemical<br>Works, Bury                                                                | Formaldehyde, pentaerythritol and dipen-<br>taerythritol, alkyd resins, bodying oils,<br>hexamine, dextrines and soluble starches                                                                                                                                                                                | —                                                                                                               |
| Beck, Koller & Co.<br>(England) Ltd.                                      | Speke, Liverpool 19                                                                             | Synthetic resins for paints, varnishes,<br>adhesives, paper, textiles; plastics, polyester<br>resins                                                                                                                                                                                                             | Large-scale phthalic anhydride plant<br>will go into production soon                                            |
| Blythe, William, & Co.<br>Ltd.                                            | Holland Bank Works,<br>Near Accrington                                                          | Inorganic chemicals, sulphuric acid, mag-<br>nesium sulphate                                                                                                                                                                                                                                                     | —                                                                                                               |
| British Nicotine Co. Ltd.                                                 | Bootle, Liverpool                                                                               | Nicotine sulphate 40% and nicotine                                                                                                                                                                                                                                                                               | —                                                                                                               |
| British Schering<br>229-231 Kensington<br>High Street, W8                 | Hazel Grove,<br>Stockport, Cheshire                                                             | Sex hormones, Neomercazole, Oblivon-C,<br>medical and agricultural chemicals                                                                                                                                                                                                                                     | —                                                                                                               |
| Clayton Aniline Co. Ltd.,<br>The                                          | Clayton,<br>Manchester 11                                                                       | Dyestuffs and dyestuffs intermediates                                                                                                                                                                                                                                                                            | Large power plant and intermediates<br>plant, ice plant, laboratories, inspec-<br>tion and testing laboratories |
| Cocker Chemical Co. Ltd.                                                  | Cocker Chemical Wrks.,<br>Oswaldtwistle                                                         | Chlorinated phenol of various kinds, DDT,<br>mercaptobenzothiazole                                                                                                                                                                                                                                               | —                                                                                                               |
| Cornbrook Chemical Co.<br>Ltd.                                            | Newbridge Lane,<br>Stockport                                                                    | Fine colours and pigments for linoleum,<br>printing inks, paints and leather-cloth                                                                                                                                                                                                                               | —                                                                                                               |
| Cory, H. E. J., Ltd.                                                      | Eagle Chemical Works,<br>Oswaldtwistle                                                          | Chlorophenols                                                                                                                                                                                                                                                                                                    | —                                                                                                               |
| Cowburn, W. H., &<br>Cowpar Ltd.                                          | Trafford Park,<br>Manchester 17                                                                 | Mainly merchants. Sulphur and sulphuric<br>acid                                                                                                                                                                                                                                                                  | —                                                                                                               |
| Crosfield, Joseph, & Co.<br>Ltd.                                          | Bank Quay,<br>Warrington                                                                        | Detergents, Na and K silicates, nickel<br>catalyst, silica fillers, silica gel                                                                                                                                                                                                                                   | Major portion of factory to be re-<br>built in next few years                                                   |
| Deodor-X Co. (England)<br>Ltd.                                            | Cromwell Road,<br>Ellesmere Port                                                                | Fine chemicals, germicidal detergents for<br>industry, etc.                                                                                                                                                                                                                                                      | —                                                                                                               |
| Edge, William, & Sons Ltd.                                                | Bolton                                                                                          | Drummer dyes, aerosols, disinfectants                                                                                                                                                                                                                                                                            | —                                                                                                               |
| Evans Medical Supplies Ltd.                                               | Speke, Liverpool 19                                                                             | Pharmaceutical products, including biolog-<br>icals, fine chemicals, drugs of veg. origin                                                                                                                                                                                                                        | New tablet department opened on<br>20 February                                                                  |
| Evans, Norman, & Rais<br>Ltd.                                             | Unity Mills, Woodley,<br>Vale Road, Heaton<br>Mersey, Stockport<br>Bankfield Mill,<br>Radcliffe | Metallic soaps, desizing agents, enzymes,<br>surface active agents, adhesives, preserva-<br>tives, and disinfectants                                                                                                                                                                                             | Two new enzymes added to range                                                                                  |
| Fine Dyestuffs & Chemicals<br>Ltd.                                        | Calder Street,<br>Manchester 2                                                                  | Dyestuffs                                                                                                                                                                                                                                                                                                        | —                                                                                                               |
| Geigy Co. Ltd.                                                            | Rhodes, Middleton,<br>Manchester                                                                | Dyestuffs for textile industry, pigments,<br>plasticisers, textile and leather chemicals,<br>pesticides and pharmaceuticals                                                                                                                                                                                      | —                                                                                                               |
| Hardman & Holden Ltd.<br>Manox House,<br>Miles Platting,<br>Manchester 10 | Miles Platting,<br>Manchester 10<br>Clayton,<br>Manchester 11<br>Albert Mill,<br>Manchester 6   | Sulphuric acid, sulphur dioxide, sulphur<br>trioxide, carbon disulphide, sodium hydro-<br>sulphite, thiourea, insoluble sulphur, iron<br>oxide, prussian blue, prussiates, metallic<br>stearates, organic stearate esters, metallic<br>naphthenates, thiocyanates, wetting agents<br>of the sulphosuccinate type | —                                                                                                               |
| Harris Hart & Co. Ltd.                                                    | Heywood                                                                                         | Magnesium sulphate, sodium sulphate                                                                                                                                                                                                                                                                              | —                                                                                                               |

| COMPANY                                                                   | PLANT                                                                               | MAIN PRODUCTS                                                                                                                                                                   | NEW PROJECTS                                                                                                                                   |
|---------------------------------------------------------------------------|-------------------------------------------------------------------------------------|---------------------------------------------------------------------------------------------------------------------------------------------------------------------------------|------------------------------------------------------------------------------------------------------------------------------------------------|
| Hess Products Ltd.                                                        | Littleborough,<br>Near Rochdale                                                     | Fatty acids, drying and semi-drying unsaturated acids, hardened castor oil, pitch, nitriles, amines, diamines, quaternary ammonium compounds                                    | Large scale operation of nitrogen derivative units in 1956                                                                                     |
| Imperial Chemical Industries Ltd.,<br>London, S.W.1                       |                                                                                     |                                                                                                                                                                                 |                                                                                                                                                |
| Alkali Division,<br>Winnington,<br>Northwich, Cheshire                    | Winnington, Wallerscote, Lostock, Middlewich and Fleetwood                          | Soda ash, caustic soda, sodium bicarbonate, soda crystals, sodium silicate, ammonium chloride and calcium chloride                                                              | Pioneer plant for calcium silicate, aluminium silicate and silica fillers starting up in 1957. Full-scale production will begin at end of 1958 |
| Billingham Division,<br>Co. Durham                                        | Morecambe and Heysham, Lancs<br>Clitheroe Works                                     | Ammonia, methanol, nitric acid and nitro-chalk<br>Catalysts                                                                                                                     | —                                                                                                                                              |
| Dyestuffs Division,<br>Hexagon House,<br>Blackley,<br>Manchester          | Blackley, Trafford Park and Burn Hall, Lancs;<br>Ellesmere Port                     | Dyestuffs, textile auxiliaries, chemicals for rubber products, synthetic resins, lacquers, nylon, drugs, medicinal and veterinary products, insecticides and agricultural cpds. | Procion range of dyestuffs introduced in 1956                                                                                                  |
| Fibres Division,<br>Harrrogate, Yorks                                     | Hillhouse Works,<br>Cleveleys, Lancs                                                | Experimental work in connection with improved fibres processing                                                                                                                 | —                                                                                                                                              |
| General Chemicals Div.,<br>Cunard Buildings,<br>Liverpool 3               | Runcorn Wade,<br>Ches., Widnes<br>Hillhouse, Lancs                                  | Chlorine, caustic soda, acids, metallic sodium, sodium cyanide, trichloroethylene, vinyl chloride and Arcton refrigerants                                                       | Arcton plant at Runcorn to be extended during 1957. Further additions to chlorine-using plants                                                 |
| Nobel Division,<br>Bothwell St., Glasgow                                  | Roburite Factory,<br>Shevington, Wigan                                              | Quarrying explosives of the non-nitro-glycerine type                                                                                                                            | —                                                                                                                                              |
| Pharmaceutical Division,<br>Fulshaw Hall,<br>Wilmslow, Cheshire           | Research centre is<br>at Wilmslow                                                   | No products manufactured in Lancs or Cheshire                                                                                                                                   | Research headquarters at Alderley Park, Cheshire, will be completed in 1957                                                                    |
| Plastics Division,<br>Welwyn Garden City,<br>Herts                        | Hillhouse Works,<br>Cleveleys, and<br>Darwen, Lancs                                 | P.t.f.e., Perspex, p.v.c., nylon monofilament, nylon moulding powders, alkathene tube                                                                                           | —                                                                                                                                              |
| Salt Division,<br>Vale Royal, Winsford                                    | Winsford and Weston<br>Point, Ches.                                                 | Salt by vacuum process and mined                                                                                                                                                | Granular and dendritic salt added to range of vacuum salt                                                                                      |
| Jones, Ellis, & Co. Ltd.                                                  | Tiviot Colour Works,<br>Stockport                                                   | Sulphated oils, pigments, locust kernel gum                                                                                                                                     | Extension of sulphated oil plant increases production by 33%                                                                                   |
| Lancashire Tar Distillers<br>Ltd.,<br>74 Corporation St.,<br>Manchester 4 | Works at Manchester,<br>Cadishead, Liverpool,<br>Accrington,<br>Preston and Salford | Refined tar, briquetting pitch, aluminium pitch, pitch for special plastics, creosotes, phenols, toluene, naphthalene                                                           | Plant at Cadishead to produce 6,000 tons naphthalene per year. Enlargement of phenol and cresol plants at Cadishead; rebuilding benzole unit   |
| Lankro Chemicals Ltd.                                                     | Bentcliffe Works,<br>Salters Lane, Eccles,<br>Manchester                            | Plasticisers for p.v.c. materials, pigments for leather                                                                                                                         | New storage installation and dispatch block to be built in next three years at cost of £100,000                                                |
| Lansil Ltd.                                                               | Caton Road,<br>Lancaster                                                            | Textiles, cellulose acetate, acetic anhydride                                                                                                                                   | —                                                                                                                                              |
| Laporte Ltd.                                                              | Baronet Works,<br>Warrington                                                        | Hydrogen peroxide                                                                                                                                                               | —                                                                                                                                              |
| Lowe, Chas., & Co.<br>(Manchester) Ltd.                                   | Reddish, Stockport                                                                  | Phenol, cresylic acid, m-cresol and o-cresol and industrial synthetic resins                                                                                                    | —                                                                                                                                              |
| Lunevale Products Ltd.                                                    | Low Mill, Halton,<br>Lancaster                                                      | Agricultural and horticultural chemicals, insecticides and fungicides, seed dressings, mercurial salts, slimicides for paper mills                                              | —                                                                                                                                              |
| Magnesium Elektron Ltd.                                                   | PO Box No. 6,<br>Swinton, Manchester                                                | Magnesium and magnesium alloys                                                                                                                                                  | —                                                                                                                                              |
| Manchester Oil Refinery<br>Ltd.                                           | Twining Road,<br>Trafford Park                                                      | Oil products from crude petroleum                                                                                                                                               | Chemical treatment plant is being increased in capacity; crude oil storage is being increased alkyl pyridine plant increased in 1956           |
| Murgatroyd's Salt &<br>Chemical Co. Ltd.                                  | Elworth, Sandbach,<br>Brooks Lane,<br>Middlewich                                    | Open pan salt, vacuum salt, caustic soda, liquid chlorine, hydrochloric acid, sodium hypochlorite                                                                               | —                                                                                                                                              |

| COMPANY                                                   | PLANT                                                       | MAIN PRODUCTS                                                                                                                                           | NEW PROJECTS                                                                                                                           |
|-----------------------------------------------------------|-------------------------------------------------------------|---------------------------------------------------------------------------------------------------------------------------------------------------------|----------------------------------------------------------------------------------------------------------------------------------------|
| National Coal Board,<br>5-27 Withy Grove,<br>Manchester 4 | Altham Coke Works,<br>Accrington, Lancs                     | Liquor ammonia, toluole, xylene, solvent<br>naphtha                                                                                                     | —                                                                                                                                      |
| Orrs Zinc-White Ltd.                                      | Vine Chemical Works,<br>Widnes                              | Zinc sulphide, lithopone, zinc chloride<br>solution, zinc sulphate, zinc tetroxychro-<br>mate, barytes, blanc fixe, barium chloride,<br>barium sulphate | —                                                                                                                                      |
| Oswald M'Cardell & Co.<br>Ltd.                            | High Grove Works,<br>Greenfield,<br>Near Oldham             | Textiles, treatment chemicals for the<br>Manchester textile industry                                                                                    | —                                                                                                                                      |
| Oxirane Ltd.                                              | Partington                                                  | Polyglycols, ethlanoamines, glycol ethyls                                                                                                               | —                                                                                                                                      |
| Palmer, Mann & Co. Ltd.                                   | Sifta Salt Works,<br>Sandbach, Cheshire                     | Table salt and all qualities of industrial salt                                                                                                         | Coal handling plant, cost about<br>£15,000                                                                                             |
| Petrochemicals Ltd.                                       | Partington,<br>Manchester                                   | Ethylene and propylene derivatives, aro-<br>matics and derivatives                                                                                      | Ziegler polythene plant on stream<br>this year, capacity 1,000 tons/year.                                                              |
| Pinnington, Dawson &<br>Wood Ltd.                         | Irwell Works, Mill<br>Street, Radcliffe,<br>Near Manchester | Magnesium sulphate, alginates and a few<br>inorganic chemicals                                                                                          | —                                                                                                                                      |
| Poole, George H., & Son<br>(Bootle) Ltd.                  | Canal Street Chemical<br>Works, Bootle,<br>Liverpool 20     | Refined borax from material supplied by<br>Borax & Chemicals Ltd.                                                                                       | New warehouse building. Ware-<br>house equipped with mechanical<br>handling equipment                                                  |
| Price's (Bromborough) Ltd.                                | Bromborough Pool,<br>Near Birkenhead                        | Oleines, stearines, textile oils, fatty acids<br>and fatty alcohols                                                                                     | Old methods being replaced by new<br>during 1956                                                                                       |
| Production Chemicals<br>(Rochdale) Ltd.                   | 32 Deansgate,<br>Manchester 3<br>Also at Rochdale           | Importers and exporters of liquid and<br>powder sulphur lye, bentonite, diatoma-<br>ceous earths, bleaching earths, wood flour                          | —                                                                                                                                      |
| Pure Chemicals Ltd.                                       | Kirkby Industrial<br>Estate,<br>Near Liverpool              | Alkyl bromides, colour photography de-<br>velopers, halogenated compounds, organo-<br>tin compounds, stabilisers for plastics                           | Plastics division technical service<br>laboratory opened in September,<br>1956. Trialkyl tin compounds being<br>examined as fungicides |
| Riley, William, (Albumens)<br>Ltd.                        | 129 Water Street,<br>Manchester 3                           | Dried blood albumen, dried blood for<br>animal feeding and fertiliser                                                                                   | —                                                                                                                                      |
| Shell Chemical Co. Ltd.                                   | Stanlow, Ellesmere<br>Port, Wirral                          | Petrochemicals, including solvents, ethane<br>and ethylene, Teepol, bitumen, xylene                                                                     | —                                                                                                                                      |
| Spence, Peter, & Sons Ltd.                                | Moorfield Road,<br>Widnes                                   | Aluminium sulphate, alumina, alumina-<br>based catalysts, organic titanium compounds                                                                    | —                                                                                                                                      |
| St. Just, Theodore, & Co.<br>Ltd.                         | Whitefield,<br>Manchester                                   | Associated with Spencer Chapman. Organic<br>compounds, perfumery intermediates, tex-<br>tile treatment chemicals                                        | —                                                                                                                                      |
| Stockport United Chemical<br>Co. Ltd.                     | Canada Street,<br>Heaviley, Stockport                       | Industrial detergents, sulphonated fatty<br>alcohols, non-ionic products and concen-<br>trated alkyl/aryl products                                      | —                                                                                                                                      |
| Storey, Joseph, & Co. Ltd.                                | Heron Chemical &<br>Colour Works,<br>Lancaster              | Pigments, driers, p.v.c. stabilisers, lead<br>borate, manganese borates, zinc borates<br>and other heavy chemicals                                      | Expansion programme under way                                                                                                          |
| The Distillers Co.,<br>(Biochemicals) Ltd.                | Speke, Liverpool 19                                         | Penicillin, streptomycin, vitamin B <sub>12</sub> , animal<br>feed products, all made by fermentation                                                   | Recently introduced phenoxy methyl<br>penicillin or penicillin V, stable in<br>acid and can be taken by mouth                          |
| United Indigo & Chemical<br>Co. Ltd.                      | Lord Street,<br>Manchester 4                                | A few dyestuffs, textile treatment chemicals                                                                                                            | —                                                                                                                                      |
| Viaduct Alum Co. Ltd.                                     | The Marsh, Widnes                                           | Aluminium sulphate, sodium aluminium<br>sulphate                                                                                                        | —                                                                                                                                      |
| Walker Extract & Chemical<br>Co. Ltd.                     | Nelson Street,<br>Bolton                                    | Tanning extracts, synthetic tanning agents                                                                                                              | New spray drying plant erected                                                                                                         |
| Warrington Chemical &<br>Drug Co. Ltd.                    | Paddington,<br>Warrington                                   | Aspirin                                                                                                                                                 | —                                                                                                                                      |
| Wolf, Victor, Ltd.                                        | Victoria Works,<br>Clayton,<br>Manchester 11                | Distilled fatty acids, glycerine, stearine,<br>pitch, esters, detergents                                                                                | —                                                                                                                                      |

## Lancashire &amp; Cheshire

# PROGRESS IN BRITAIN'S TRADITIONAL HEAVY CHEMICAL CENTRE

**D**URING the past decade development in the chemical industry has been rapid. This has been particularly true in Lancashire and Cheshire, traditional chemical centres in the UK. In the following pages we review recent advances in the industry in these two counties.

Recent developments carried out by THE CLAYTON ANILINE COMPANY, Clayton, Manchester, include a large modern power plant designed to supply the whole of the factory with steam and electricity. Latest new construction work in the dyestuffs intermediates division is a multi-storey building with a total volume of about 2,500,000 cu. ft. and a working floor area of about 150,000 sq. ft. At present under construction is a new plant for the production of ice, and work is proceeding on extensions to laboratories where inspection and testing of intermediates products, raw materials and finished products is carried out.

Over the next eight years a major portion of the works of JOSEPH CROSFIELD AND SONS, Warrington, will be rebuilt at an estimated cost of over £5 million. As a result of this plan, production will be concentrated on the northern bank of the River Mersey which at present divides the factory in two. Four years ago a £1 million plant was opened for the manufacture of synthetic catalyst used for the catalytic cracking of petroleum feedstocks. Products manufactured at Warrington include detergents, sodium and potassium silicates, silica gel, ion exchange materials, catalysts and silica fillers.

The plastics division of PURE CHEMICALS, Kirkby Industrial Estate, near Liverpool, opened a technical service laboratory in September last year. This provides a complete small scale factory for every type of process in which vinyl chloride resins are used.

One of the latest developments by Pure Chemicals is the use of organotin compounds. Trialkyl tin compounds have high fungicidal activity and their use is being tried in a number of industries including surface coating, pulp and paper, timber preservation, and textile proofing. Pure Chemicals was the first, and claims to be the largest, manufacturer of these compounds in this country.

SIX OF IMPERIAL CHEMICAL INDUSTRIES' manufacturing divisions have their headquarters in Lancashire and Cheshire.

They are the alkali, general chemicals, dyestuffs, salt, leathercloth and pharmaceuticals divisions. Other plants in the two counties belong to the Billingham, fibres, plastics and Nobel divisions.

Five of the seven factories of the alkali division are in the two counties. They are at Winnington, Wallerscote, Lostock, and Middlewich in Cheshire and at Fleetwood, Lancashire. The main products are alkalis—soda ash, caustic soda, bicarbonate of soda, soda crystals and sodium silicate.

A development during 1957 will be the starting up of pioneer plant for calcium silicate, aluminium silicate and silica fillers (now increasingly used in synthetic shoe soling). Full-scale production will begin at the end of 1958.

The general chemicals division, which employs about 12,500 people, operates 13 factories, most of them in Cheshire and Lancashire. In Cheshire, plants are located in Runcorn and mid-Cheshire, and in Lancashire, in Widnes and on the Fylde.

## Runcorn Extensions

During 1957 the division expects to bring into operation a new extension to the Arcton plant at Runcorn, and there will also be further additions to chlorine-using plants, particularly chlorinated solvents. The new Thornton power station, which will supply steam and electricity to the company's works in the Fleetwood area, is also expected to be partially in operation during the year.

The salt division claims to be the largest single producer of salt in Great Britain. The major part of its activities are in Cheshire, at Winsford and Weston Point, near Runcorn. The bulk of production is by the vacuum process of brine evaporation but the division also works the only salt mine still operating in this country. Rock salt from this mine (at Winsford) is widely used for agricultural purposes, and for clearing roads of ice and snow.

Two new types of vacuum salt—granular and dendritic—have recently been introduced. The most important recent development in the division has been the introduction of mechanised bulk delivery methods, using specially designed vehicles with air discharge systems.

Three dyestuffs division plants are in Lancashire—at Blackley, Trafford Park and Burn Hall. The first concentrates on dyestuffs, intermediates for dyestuffs, rubber chemicals, pigments and lakes.

The Trafford Park plant makes penicillin as well as dyestuffs and intermediate products. The Burn Hall plant is for the manufacture of colour film. In Cheshire, the division has a synthetic indigo plant at Ellesmere Port. Altogether, the division (which employs over 14,000 people) makes over 6,000 products. They include, in addition to dyestuffs, textile auxiliary products; chemicals for the manufacture of rubber products; synthetic resins for high-quality paints, lacquers and other surface coatings; nylon polymer; synthetic drugs and medicinal products; veterinary compounds; insecticides and agricultural chemicals.

The Blackley laboratories are the largest centre of organic chemical research in the British Commonwealth.

A significant recent achievement has been the introduction in 1956 of the Procion range of dyestuffs for cellulose fibres. These dyestuffs are brilliant in shade and have good washing and light fastness.

The pharmaceuticals division already has extensive research establishments but so rapidly has the need for further facilities grown that new research headquarters are being built at Alderley Park. These will be completed during 1957.

In their plants at Liverpool and Runcorn EVANS MEDICAL SUPPLIES manufacture pharmaceutical products including biologicals, fine chemicals and drugs of vegetable origin. On 20 February this year a new tablet department was opened at Speke, Liverpool. The building is of very modern design and is air-conditioned. A plenum system ensures that the correct temperature is maintained throughout. Construction is of steel with suspended floor and ceiling and some of the walls are of steel partitioning which can be taken down at short notice and the design of the interior remoulded without causing major structural alterations.

## Burmese Agreement

Under an agreement between Evans Medical and the Burmese Government, the company has undertaken to assist in the setting up of a pharmaceutical industry in Burma and to manage the industry for an initial period of seven years. The scientific knowledge necessary for the manufacture of a wide range of products will be made available by Evans Medical.

PALMER MANN AND CO., of Sandbach, manufacturers of Sifta Salt, have recently installed a coal handling plant at a cost of about £15,000. Apart from domestic salt, the company manufactures all qualities of industrial salt, including stoved vacuum salt, unstoved vacuum salt and crystal salt.

Modern mechanical handling equipment has been installed in the new warehouse of GEORGE H. POOLE AND SON (BOOTLE), completed in 1956. Storage capacity has been increased by 1,000 tons. A subsidiary of Borax and Chemicals, this company is engaged in the processing and refining of borax and boric acid supplied by the parent company. A refining plant for the production of pharmaceutical grade borax is also



operated. The company's warehouses are the main stock depot in the UK for the parent company.

Plant erected by MANCHESTER OIL REFINERY in 1955 for the manufacture of alkyl pyridines was increased in capacity during 1956 by the installation of further distillation equipment. Further increase in the production of fine chemicals is planned.

The chemical treatment plant is being increased in capacity and a wider range

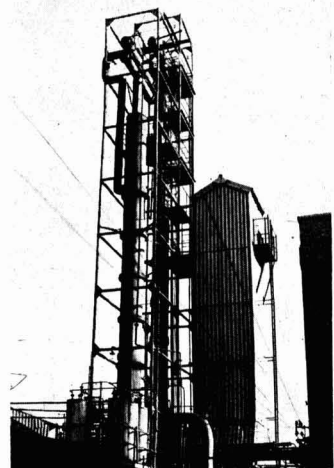

**Distillation plant of the Manchester Oil Refinery used for the manufacture of alkyl pyridines. This plant was increased in capacity during 1956 by the installation of a second column**

of products will be manufactured. The additional plant is expected to be ready for trial runs within the next two months.

Crude oil storage facilities are also to be improved by the erection of additional bulk tankage. This is scheduled for completion in 1958.

BRITISH SCHERING, Hazel Grove, Stockport, manufacturers of medicinal and agricultural chemical products, has recently produced a new drug, methylpentynyl carbamate (Oblivon-C). This is a solid derivative of Oblivon which is claimed to retain its apprehension relieving effects for as long as five hours. The Research Institute of British Schering, situated at Alderley Edge, Cheshire, is concerned with original chemical and pharmacological research on new therapeutic compounds. According to the company there is a promise of many more original and useful compounds in the future.

A short time after the end of the second world war LANKRO CHEMICALS, Eccles, Manchester, began to manufacture phthalate esters. Since that time the plant has grown and now they turn out about 8,000 tons a year of esters, including phenoxy acetic acid ester weedkillers.

Recently plant has been installed to use high strength hydrogen peroxide in the manufacture of epoxidised monoesters and triglycerides.

**New cat-cracker at Shell's Stanlow refinery which turns out products at the rate of over one million tons a year**

During the next three years Lankro plan to build, at a cost of about £100,000, a new storage installation and dispatch block which will incorporate devices for the quick, safe and efficient handling of liquids in bulk and in drum.

A new intermediate storage plant and a control weighing installation, which is claimed to ensure stringent quality control over all products before entering the finished product tanks, have recently been completed.

Aluminium sulphate in its various forms is produced by THE ALUMINA CO. at its two Widnes plants. Uses for this material are found in the following industries: Papermaking, water purification, effluent treatment, colour making, pharmaceuticals and tanning. Methods of production have been improved in recent years, claims the company, and the degree of mechanisation has been increased with a corresponding increase in productivity.

The main interests of the LIVERPOOL BORAX CO., Maxwell Square, Liverpool, are borax and boric acid, detergents for the textile and laundry trades, and alginates. A branch company, FEED-WATER SPECIALISTS, is concerned solely with steam plant problems originating in water supplies, and the treatment of process waters. Another branch, ANDREW MAXWELL, confines its activities to bituminous coatings for industry and shipping, and detergents for bottle washing and paint cleaning.

SHELL CHEMICAL CO., which claims to be foremost in the introduction of petroleum chemicals into this country, manufactures about 40,000 tons a year of solvents at its Stanlow, Ellesmere Port, refinery. Mainly ketones and alcohols, these are made from the propylene and butylene which are present in the gas streams from the gas separation unit.

A large amount of sulphuric acid is used in lubeoil treatment and in the manufacture of chemicals and the Stanlow refinery makes its own from hydrogen sulphide obtained from the gas

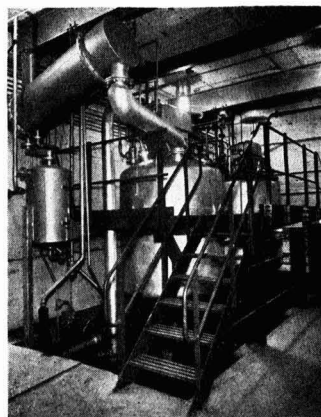

**Pepton 22 plant reaction vessels of the Anchor Chemical Company**

separation unit and the hydrodesulphuriser. Acid sludges from the treating process are decomposed in large rotating kilns and the sulphur dioxide formed is also converted into sulphuric acid in the same plant.

Other products from Stanlow include Teepol synthetic detergent, ethane and ethylene, Epikote resins, bitumen and xylene.

Curing agents for epoxide resins are manufactured by ANCHOR CHEMICAL CO., Clayton, Manchester. These include EDA Adduct 870 (available as a free-flowing powder or in solution form) and curing Agent 311 (activator of epoxide/urea-formaldehyde resin blends) both of which are for use in surface coating and laminating applications; together with Amine K54 and Amine Salt K61B which are room temperature curing agents for use in casting and potting.

Other products of this company include chemicals for rubber, paint, printing ink, oil and grease, and allied trades. General consumer service and research

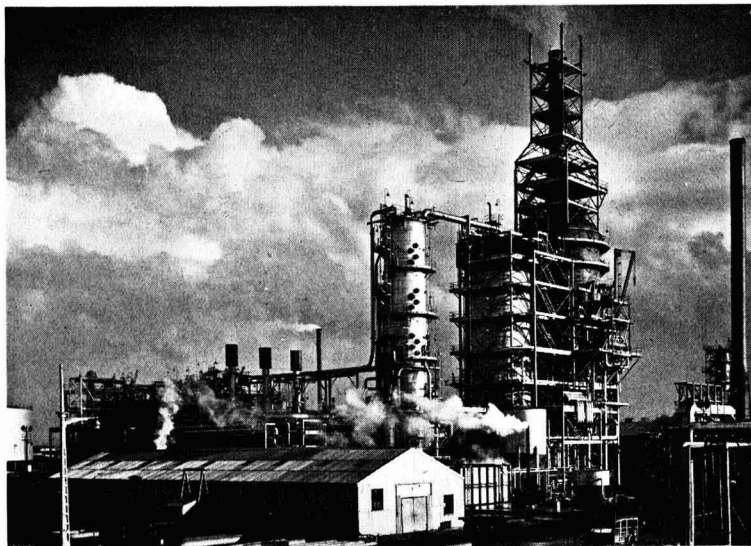

**Distillation columns of the naphthalene plant of Petrochemicals at Partington, Manchester**

chemicals, a Shell subsidiary, may be mentioned; polyethylene glycols, isopropanol benzene, toluene, naphthalene and dicyclopentadiene.

A new formaldehyde unit has recently been installed in the Bury works of ARTHUR ASHWORTH LTD., adding to the capacity of high grade standardised formaldehyde for supply to industry. The latest automatic control instruments are embodied in this plant.

In addition a new unit has been installed in the hexamine section to produce lubricated and unlubricated hexamine for the plastics industry. Other products of this company include pentaerythritol, which is made for WALKER EXTRACT AND CHEMICAL CO., Bolton dextrines and soluble starches.

Major development by PETER SPENCE AND SONS, Widnes, during recent years is the production of catalysts, of which many types, based chiefly on alumina, are produced mainly to customers' requirements. Large quantities of Comox (cobalt and molybdenum oxides on alumina) have been supplied to oil refineries throughout the world for hydrotreating petroleum hydrocarbons. A pelleting installation, probably the largest in the UK chemical industry, is in continuous operation for the manufacture of catalysts for petroleum refineries throughout the world.

Three years ago, in association with British Titan Products, Spence formed Titanium Intermediates Ltd. for the manufacture of titanium tetrachloride. The company's interest in titanium tetrachloride has led to the development of organic compounds of titanium which are finding application in waterproofing compositions, and as aids to the dispersion of pigments in paints and varnishes.

The process of replacing old methods by new in the Bromborough Pool Works of the century-old firm of PRICE'S (BROMBOROUGH) LTD., continued during 1956. They specialise in the manufacture of oleines, stearines, textile oils, fatty acids and fatty alcohols. Recent developments include the production of newer types of semi-drying fatty acids, now in increasing demand for the production of alkyl resins.

The separation of fatty acids into their solid and liquid components is now

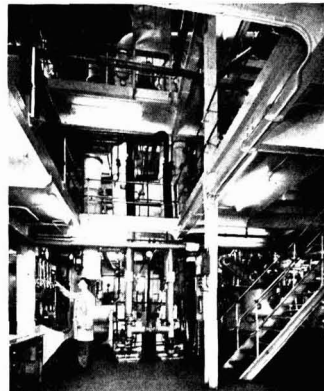

**Fatty acid distillation plant of Price's (Bromborough)**

carried out by a continuous solvent separation process, developed in the US and for which Price's hold the rights in this country. Of the stearine products the higher grades find outlets in the pharmaceutical and cosmetic industry, while chemical manufacturers, soapmakers etc., employ intermediate grades. Oleines range from an extra pale pharmaceutical quality to darker coloured grades for printing inks and veterinary emulsions.

Price's fatty alcohols range from the solid stearyl and cetyl blends to a white liquid oleyl alcohol principally used in chemical manufacture, as a textile additive, and in production of pharmaceutical products and stencils.

(Continued on page 552)

laboratories are maintained at Clayton. In addition the company acts as UK agents for a number of US companies.

Overall production of liquid chlorine at the Elworth, Sandbach, Cheshire, works of MURGATROYD'S SALT AND CHEMICAL CO. has been increased to about 30,000 tons a year and that of caustic soda to about 35,000 tons a year as the result of extensions to plant carried out in 1956. Murgatroyd's is jointly owned by The Distillers Co. and Fisons and the increased output will be taken up largely by DCL p.v.c. and Fisons' industrial and pharmaceutical interests.

Uhdé mercury cells, of German design, are used for the preparation of caustic soda and chlorine. The plant is in continuous operation and employs about 350 people.

Latest project undertaken by HARDMAN AND HOLDEN, Miles Platting, Manchester, is the manufacture of stabilised sulphur trioxide sold under the name of Sulfan. The rights for production and sale in this country were acquired from the Allied Chemical and Dye Corporation in the US. Plant for the manufacture of this product is now nearing completion and it is expected that full scale production will begin in the early summer.

The research and development facilities of the company are being extended by the building of new research and application laboratories which are now nearing completion.

Starting from petroleum naphtha, PETROCHEMICALS LTD. produces over eighty separate organic chemical products at its works on the Partington Industrial Estate, Urmston, Manchester. In the early summer a new plant for the production of Ziegler polythene will come into production with an annual capacity of 1,000 tons.

Among the products made by Petro-



**Pelleting installation in continuous operation for the manufacture of catalysts for petroleum refineries throughout the world. Operated by Peter Spence and Sons, it is thought to be the largest in the UK chemical industry**

Lancashire & Cheshire

# Chemical Engineering and Supplying Industries of the North-West

**W**ITH such a large and virile chemical industry in the two counties, it is not surprising that the area also includes several important chemical engineering concerns. The following survey lists, for one firm alone, a number of sulphuric acid plants on which work is in hand or has recently been completed in the UK or overseas which will provide a total capacity of 1,553 tons of acid a day. This list is by no means complete.

Also included in this survey are many other Lancashire and Cheshire firms that supply plant and equipment to the chemical industry.

## Stainless Steel Plant

Main interest of Stainless Steel Plant Ltd., designers and fabricators of stainless steel chemical plant, Walden Estate Cocker Street Works, Blackpool, is distillation plant, stills, mixing vessels, storage vessels, jacketed pans, heat exchangers, and tailor made plant to customers' detailed specifications.

Projects in hand include bulk storage tanks, synthetic resin plants of 12 ft. by 6 ft. diameter, jacketed hoppers, mixing vessels containers and trays ranging from 18 s.w.g. to  $\frac{1}{4}$  in. plate.

## Homogeneous Linings

Alliance (Chemical Plant) Ltd., Third Avenue, Trafford Park, Manchester 17, formed in association with Thos. Oldham Ltd., constructional engineers, and Alliance (Manchester) Ltd., lead sheet and pipe manufacturers, produce mild steel and stainless fabrications; lead-lined, jacketed and heated vessels; agitators, piping and fittings, coils and condensers.

This range includes mild steel vessels up to 10 ft. dia. by 20 ft. long, maximum  $\frac{1}{2}$  in. plate, or  $\frac{1}{4}$  in. plate in stainless steel. All kinds of chemical lead burning work can be handled, including tin-free homogeneous linings.

Homogeneous covering of copper tube or rod, by extrusion, is carried out, and the company supplies heating and cooling coils, anodes etc., made from this material.

## Plant for Tar Products

Chemical Engineering Wiltons Ltd., Bird Hall Lane, Cheadle Heath, Stockport, Cheshire, design and build plants for continuous tar distillation, tar acid recovery and refining, naphthalene production, benzole recovery and rectification, solvent recovery, crude concen-

*Concentrated ammonia liquor plant erected at Stockport gasworks by Simon Carves*

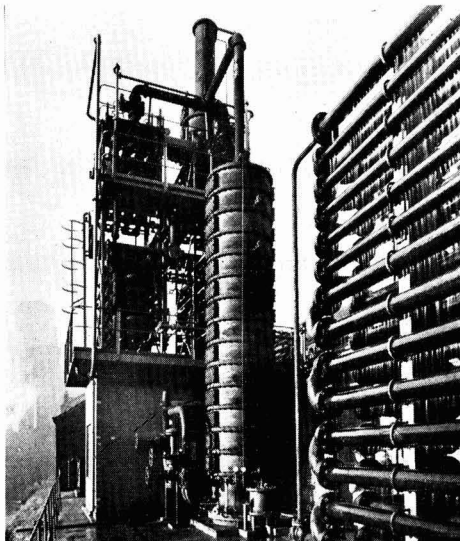

trated ammonia, pure ammonia, sulphate of ammonia, ammonia washing, and acid effluent treatment.

Plants built in Lancashire and Cheshire include a concentrated ammonia liquor plant for the North Western Gas Board's Bradford Road Gas Works, Manchester, a continuous tar distillation plant for Lancashire Tar Distillers Ltd., Litherland, Liverpool, a tar acid recovery plant for Lancashire Tar Distillers Ltd., at Cadishead, near Manchester, and an effluent neutralisation plant for Clayton Aniline Co. Ltd., Manchester.

The company recently completed a continuous tar distillation plant for Dorman Long (Chemicals) Ltd., at Middlesbrough, a concentrated ammonia liquor plant for the National Coal Board at Manvers Main, and the complete tar works at the Avenue Carbonisation and Chemical Plant at Wingerworth for the National Coal Board.

Among plants at present under construction in the UK are a continuous tar distillation plant for Lancashire Tar

Distillers Ltd., at Preston, and a continuous tar distillation plant for Scottish Tar Distillers Ltd., at Falkirk.

## Chemical Plant by Simon-Carves

A heavy constructional programme is in hand by Simon-Carves Ltd., Cheadle Heath, Stockport, designers and builders of sulphuric acid plants (contact and Kachkaroff intensive tower) sulphur recovery plant, electro-precipitators and gasworks by-products plant. Recent projects in Lancashire and Cheshire include electro-precipitators for flue dust removal for the Central Electricity Authority at Oldham, Accrington, Fleetwood and St. Helens.

Among plants completed in recent months are a sulphur-burning sulphuric acid plant with an acid production of 175 tons a day for Scottish Agricultural Industries Ltd., Leith; Kachkaroff intensive tower sulphuric acid plant using spent oxide for the National Coal Board's

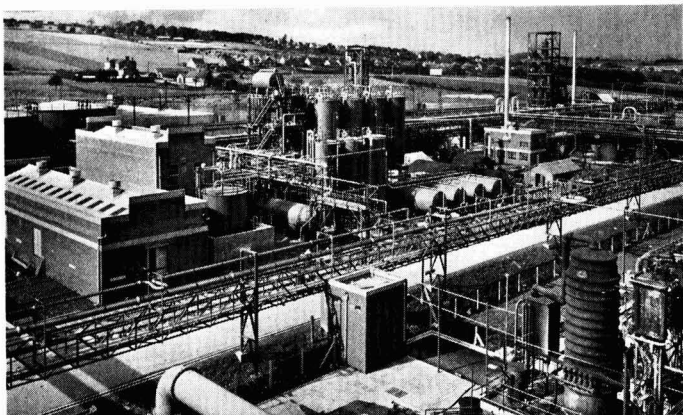

*General view of complete tar works (with naphthalene plant in middle distance), for the NCB at Avenue Carbonisation and Chemical Plant, Wingerworth. Installation by Chemical Engineering Wiltons Ltd.*

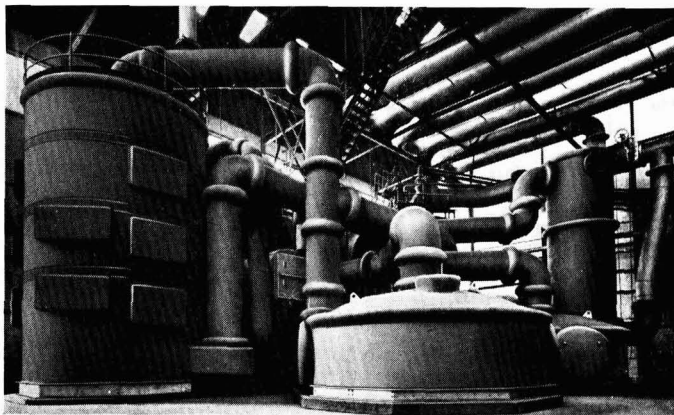

*Sulphur-burning sulphuric acid plant by Simon-Carves for Courtaulds Ltd., at Trafford Park*

Wingerworth carbonisation and chemical plant; sulphur-burning sulphuric acid plant with acid production of 110 tons a day for the East Coast Farmers' Fertiliser Co. Ltd., New Zealand; pyrites-burning sulphuric acid plant with a daily acid production of 134 tons for the Blyvooruitzicht Gold Mining Co. Ltd., South Africa; sulphur-burning sulphuric acid plants (20 tons a day of acid in each case) for Shaw Wallace and Co., India, and Century Rayon of India; and a similar plant with a daily acid production of 110 tons for Eerste Nederlandsche Coöperatieve Kunststufabriek, Holland.

Simon-Carves plants under construction include a pyrites-burning sulphuric acid plant with a daily acid production of 184 tons for African Explosives and Chemical Industries Ltd., South Africa; and the following sulphur-burning sulphuric acid plants (daily acid production in brackets) Indian Iron and Steel Co. Ltd., Hirapur (50 tons); ICI Ltd., India (10 tons); Kiwi Fertiliser Co. Ltd., New Zealand (110 tons);; DHA (Chemicals) Ltd., Australia (20 tons); Territory Enterprises Pty Ltd., Australia, (30 tons); R. and J. Garroway Ltd., Scotland (150 tons).

Plants recently ordered from Simon-Carves include the following sulphur-burning sulphuric acid plants: Indian Government's new steelworks at Durgapur (60 tons); Southland Cooperative Phosphate Co. Ltd., New Zealand (110 tons); Mary Kathleen Uranium Ltd., Australia (110 tons) Bay of Plenty Fertiliser Works Ltd., New Zealand (110 tons); Fisons Ltd., Immingham (140 tons).

Contracts for coke oven and by-product plant construction and reconstruction are in progress in Britain for Dorman Long (Steel) Ltd., the Steel Co. of Wales, ICI, the National Coal Board and others. Similar contracts are in progress in India for the new Durgapur steelworks, for the Tata Iron and Steel Co. and the Indian Iron and Steel Co.

### Chemical Plant Steelwork

Specialising in steelwork in chemical plant structures, Robert Watson and Co. (Constructional Engineers) Ltd., Bolton, have in hand, or have recently completed the following projects: steel for

buildings and plant structures to the instructions of Simon-Carves Ltd., for various chemical plants; vessels for the Fawley synthetic rubber plant to the instructions of Matthew Hall Ltd.; vessels for plant at Wilton, Yorks for Kellogg International Corporation Ltd.

Their head office and No. 1 works (welding department) are at High Street, Bolton; No. 2 works (structural department) is at Higher Swan Lane, Bolton. The company's range in steelwork for chemical plant structures covers buildings, pressure vessels, tanks, chimney stacks and pipes 36 in. diameter and up.

### Spray Nozzles

Specialists in the production of spray nozzles for industry and agriculture, H. T. Watson Ltd., Croft Street, Widnes, are now working on nozzles for steel strip descaling, for various types of air washes in the air conditioning field, gas-scrubbing towers, dust quenching in ash-handling plants, suppression of foam on

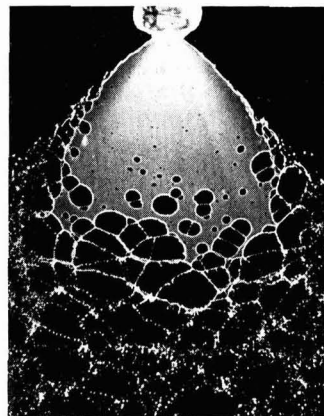

*High speed photograph of a fan or flat spray nozzle, by H. T. Watson Ltd., shows mode of formation of drops. (1) Puncture of film causing holes with thick rims; (2) break up of rims into ligaments of liquid; (3) final break up of ligaments into drops*

sewage tanks, and fine precision misting nozzles for producing humid conditions.

Nozzles are manufactured as standard in brass and 18/8/3 stainless steel, but can be produced in phosphor bronze, hard rubber, hard lead, and aluminium alloys. A special series is made in ceramics, which combined with hard lead housings, provide resistance to highly corrosive conditions met with in the chemical industry.

Models range from cone sprays giving 'full' or 'hollow' cone spray characteristics in outputs from as low as 0.5 galls/hour up to large 6 in. pipe size units passing 600 lb./minute or more. Oil burner pressure jets nozzles are also made from 0.75 galls/hour upwards with threads to American standards, thus making them interchangeable.

### Fabricated Steelwork

Main products of the Widnes Foundry and Engineering Co. Ltd., Lugsdale Road, Widnes, are heavy iron castings and fabricated steelwork for the atomic, chemical, oil, food and allied industries.

### Instrument Research

One of the country's foremost instrumentation specialists, Fielden Electronics Ltd. have their headquarters at Wythen-shawe, Manchester 22. In their range of electronic industrial instruments are level controllers and indicators, temperature controllers and indicators, pressure transmitters and micromasuring instruments. For the textile industry, they manufacture the Fielden-Walker yarn evenness recorder and the Drimeter type B3 moisture measurer.

Perhaps their most important project of the past few months has been the establishment of an associated company, Fielden Research Ltd. at Bangor, North Wales. This company will develop new instruments which will be added to the range of Fielden Electronics. It is also hoped that the research unit will provide a general advisory service to industry's more complete instrumentation problems.

### Lifting Equipment

Suppliers of electric, hand and travelling cranes and pulley blocks to ICI Ltd. and many other chemical firms in the area, the Vaughan Crane Co. Ltd., West Gorton, Manchester 12, have constructional departments at Trafford Park, Manchester 17, and Strangeways Ironworks, Manchester 2. Their range includes electric and hand powered overhead travelling cranes, up to 150 tons capacity; manual and electric hoist blocks; runway systems, telfers, jib cranes etc.

### Conveying Equipment

Main products of Bivac Air Co. Ltd., Beehive Works, Portwood, Stockport, are pneumatic conveying of granular materials, the special filtration of very fine 'difficult' powders, vacuum cleaning installations for boiler houses and factories in general, and portable industrial vacuum cleaning plants.

In a typical pneumatic conveying plant, the powder is unloaded from a grinding mill into a hopper, and from the hopper into one or two Bivac fluid-

ised hoppers, which are emptied by suction, the dust being conveyed into the primary separator, where it is continuously discharged through a star valve into a still. After processing in the still the powder is removed into the second storage container, and suitably bagged off through the valve at the bottom of the container.

This particular installation operates with a turbo exhauster creating a depression throughout the system, and is capable of handling about two tons an hour. The powder employed is extremely fine and the Bivac 'Clear-Flo' filter is used.

### Pumps for Chemical Industry

Pumps produced by Rhodes, Brydon and Youatt Ltd., Waterloo Engineering Works, Stockport, Cheshire, include Mopump centrifugal pumps; for chemical and process duties, acids, alkalis, solvents, molten salts, sulphur and metals; horizontal end-suction pumps in unit construction with motor, or pedestal types for direct or vee-belt drive from motor, engine or turbine; suspended vertical for sump or vat drainage or transfer, with discharge up shaft column or via separate rising main; high temperature water circulation pumps, horizontal for static pressures up to 150 p.s.i. or vertical for 350 p.s.i.; rubber or vulcanite lined pumps in all types.

### Gelatine Machinery

Machinery for the manufacture of gelatine, spiral blades in composite iron and steel, bronze, stainless steel etc., for all types of spirally bladed cylinders and tanning and leather dressing machinery are the specialities of Edward Wilson and Son Ltd., Aintree Road, Bootle, Liverpool 20. The company incorporates John Melbourne Ltd., Warrington.

### Vee Belting

Two new extensions have recently been completed to the works at Rose and Crown Street, Warrington, of T. Whittle and Sons Ltd. This firm specialises in laminated rubber link vee-belting, leather link vee-belting and CI vee-pulleys.

### Steel Drum Machinery

Moon Brothers Ltd., Beaufort Road, Birkenhead, are manufacturers of machinery for the production of steel drums, tin boxes and screw caps; they are also power press manufacturers. Among recent projects are plant for the manufacture of 4 gallon petrol tins and various sizes of lubricating oils for one of the large oil companies; this plant is destined for the Middle East.

At present the company is working on contracts for plant that will manufacture 36 lb., 18 lb. and 9 lb. containers to hold vegetable ghee and edible oils; this is destined for Uganda; a plant for the manufacture of 40 gallon caustic soda drums, destined for India; and high speed automatic cap production machines.

### Polythene Bags

Merseyside's only makers of polythene film, Henry Jackson (Liverpool) Ltd., have acquired new premises opposite

*New Danish vacuum shelf drier by Calmic Engineering Co. Ltd.*

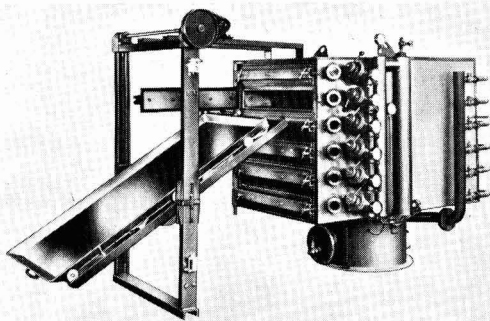

their present factory at 65/67 Admiral Street, Liverpool 8. The space available, about 20,000 sq. ft., will house further extrusion and bag-making plants. A production of some 800 tons a years is envisaged.

Founded in 1900, the firm's manufacturing capacity has been developed almost entirely since 1946. As one of the leading makers of hand made paper bags, the company was approached some time ago by Imperial Chemical Industries Ltd. with a view to converting their production to polythene bags of all shapes and sizes.

First in the country to make polythene block-bottom bags by paper-bag techniques, the company has helped pioneer the use of polythene drum liners in the chemical industry and was the first to promote polythene liner bags for the semi-bulk packing of cooking fat. Mr. G. A. and Mr. C. D. Collins, directors, have visited the US on a number of occasions to study new techniques and potential uses.

With a view to improving service and lowering prices, Henry Jackson (Liverpool) Ltd., decided a few years ago to make their own polythene film and now the complete operation—from the production of film to finished bag—takes place in their factory.

### Filter Cloths

Samuel Hill Ltd., Lark Mill, Hare Street, Rochdale, are stockists and makers-up of all types of filter cloths, particularly for the chemical industry. The company has its own weaving department to enable it to meet special requirements. Established for more than 80 years, the company is a subsidiary of Oswald and Duncan Ltd., Mayfield Mill, Rochdale, manufacturers of cotton, canvas and synthetic industrial cloth.

### Vacuum Shelf Dryer

Chemical plant, including a special Danish vacuum shelf drier, is manufactured by Calmic Engineering Co. Ltd., Crewe Hall, Crewe, Cheshire. Manufacture of the vacuum shelf drier has only recently commenced. It is claimed to have completely revolutionised vacuum drying technique. The company will manufacture it for the Canadian, Australian and South Africa markets in addition to the UK and production is reported to be expanding rapidly.

Main points of advantage of this machine are said to be the greatly im-

proved thermal conductivity and its ability to work semi-continuously.

The ALA vacuum dryer is capable of drying in the absence of air and light, many pharmaceutical products, paint pigments, dyestuffs, food and vegetable extract, yeast and yeast extracts, pepsin, pectin, photohormones and fine chemicals.

### Fire Protection Equipment

Mather and Platt Ltd. have two plants in Lancashire—Park Works, Manchester 10 and Radcliffe Works, Radcliffe, Manchester.

Products comprise: fire protection equipment, including the Grinnell automatic sprinkler and fire alarm system; electric motors and generators; centrifugal pumps for all purposes; canning machinery for the processing of fish, fruit, meat and vegetables and the quick-freeze industry; and packaging machinery.

### Epikote Linings

Application of surface coatings—Epikote, Araldite, p.t.f.e. dispersion coating, silicones, phenolics, p.v.c. and stoving enamels—is carried out by Loyne Ltd., Junction Mills, Margaret Street, Ashton-under-Lyne, Lancashire.

Recent work includes Epikote lining of gas washing plant, brewery tanks, holds in fuel tankers and cargo vessels and fuel tanks in aircraft carriers.

The Epikote lining of the gas washing plant was carried out for Simon-Carves Ltd., who erected the plant at Nottingham Power Station. Perforation plates, distribution plates and spray eliminator units were coated in Loyne's works and the rest of the unit was coated on site. The system used was shotblasting and coating with five coated Epinamel A/C forced drying white enamel supplied by Arthur Holden and Sons Ltd., Birmingham. Curing of the coating was done in convection ovens at the works and on site by means of portable infra-red units.

Loyne Ltd. state that the latest development is the growing use of p.t.f.e. dispersion coating for 'non-stick' purposes.

### Rubber, Ebonite and Synthetics

Products of Redferns (Bredbury) Ltd., Stockport Road, Bredbury, Cheshire, include lining and covering in rubber, ebonite or synthetics, tanks, pipes, ducting, chimneys, chutes, towers, agitators, vats, pumps and castings; roller cover-

ings in rubber and ebonite; laminated rubber and ebonite utensils; solid ebonite barrels and dipping baskets.

### Filtering Materials

Chemical and pharmaceutical sheet filters, kieselguhr filters, alluvial filters, Carlson original filter sheets and loose asbestos filtering material, experimental filters, filter presses (jacketed and standard models), storage and pressure tanks, and tincture presses are manufactured by John C. Carlson Ltd., Newman Street, Ashton-under-Lyne, Lancs.

Carlson filters are manufactured in stainless steel, light metal aluminium alloy specially lacquered, and Noloc—a non-corroding light metal alloy which does not require protective lacquering.

Typical applications are in heavy chemicals, petroleum, organic chemicals, animal and vegetable oils, textile industries, general industry, sugar, paints, varnishes and lacquers, light chemicals, cosmetics and perfumes, pharmaceuticals and antibiotics.

### Steel Containers

Manufacturing a wide range of steel containers, including kegs, drums, tapers and painters' pots, are G. T. Johnson and Co. Ltd., 63 Great George Street, Liverpool 1.

### Carboy Hampers

Leigh and Sons Metal Works Ltd., Orlando Street, Bolton, are wholly concerned with the production of carboy hampers and safety crates in steel strip under the trade mark Zulo. The company also factors carboys and supplies the complete package in 5 and 10 gall capacities.

An old-established concern, Leigh and Sons were the inventors of carboy hampers and have capacity for increased production. Their range extends beyond the standard 5 and 10 gall sizes and they specialise in making cylindrical steel strip hampers to customers' own requirements.

### Tabletting Machines

Manesty Machines Ltd., Evans Road, Speke, Liverpool 19, plan to extend their works during 1957 and to build new offices, an experimental laboratory and showroom at Speke. They also have works at Milnrow, Lancs. Apart from tabletting machinery, this company also produces punches and dies and automatic water stills.

### Industrial Doors

Shutter doors, collapsible gates, fireproof doors, Superfold doors and upward lifting count regrilles are the main products of the Bolton Gate Co., Ltd., Waterloo Street, Bolton. Recently introduced is a special operating unit for the automatic opening and closing of factory entrance gates. Fireproof shutter doors are manufactured to meet the regulations of the Fire Offices' Committee.

### Ferranti Instruments

Ferranti Ltd., Hollinwood, one of the leading companies in the UK electrical

industry, are one of the few large industrial concerns to retain a strong family association from the earliest days. They have factories at West Gorton, Wythenshawe, Edinburgh, Toronto, Moston, Oldham, Dundee and New York.

The range of the instrument department includes: microammeters, milliammeters, induction and dynamometer wattmeters, power factor indicators, synchrosopes and frequency indicators, cell testing voltmeters, hermetically sealed instruments, Tesvac vacuum tester, industrial servo guiding equipment, rotational viscometers etc.

The Ferranti foundry produces castings in grey iron Nomag, NoduMag and SG iron up to 5 tons in weight. In NoduMag and SG iron, the graphite is in spheroidal form and both are produced under licence from the Mond Nickel Co.

### Travelling Exhibition

A travelling exhibition, designed to show the full extent of the manufacturing resources and experiences of Lorival Plastics (United Ebonite and Lorival Ltd.), Little Lever, near Bolton, is now touring industrial centres of England, Scotland and Wales.

The Lorival factory specialises in the production of hard rubber products; plastics mouldings, extrusions and sheeting; pure liquid rubber and liquid rubber compounds. Its facilities include large physical and chemical

laboratories and a fully equipped experimental production department.

One of the sections of the travelling display demonstrates the facilities offered to battery makers and includes hard rubber starter battery containers, industrial battery boxes, cell lids, finned tubes and injection-moulded baffle vent plugs. A more recent Lorival development occupies the other section. This is CRP, a compound of liquid rubber for casting printing rollers. These rollers are not affected by humidity and can be varied in hardness from 5° to 35° Shore.

### Fabricated Plant

All forms of fabricated plant for the chemical, petroleum, steel, coal, gas and electrical industries are produced by Wm. Neill and Son (St. Helens) Ltd., Bold Iron Works, St. Helens Junction, Lancs. The company have further works at Parr Works, St. Helens, Lancs:

In connection with their storage tanks and structural steel work, the company provide shotblasting and metal spraying.

The company are the British licensee and manufacturers of Varec tank fittings. Pressure and vacuum and other valves are produced in a variety of materials, together with flame arresters and tank gauging equipment.

Electronic equipment is being developed for attachment to the company's mechanical gauges which will enable the contents of tanks to be transmitted for remote reading.

## Chemical Progress in the North West

(Continued from page 548)

With the outbreak of the second world war supplies of bacterial desizing agents and other enzymes previously imported from France, were cut off and consequently NORMAN EVANS AND RAIS decided to make supplies in this country. After considerable difficulty a start was made on the production of bacterial amylase. To this first product has been added a refined grade of amylase for use in the foodstuffs industry, as well as a number of enzymes for the breakdown of proteins, locust bean gum and pectin etc., as well as others for use in various applications in the leather and other industries.

It became obvious that the original factory at Cheadle was too small and shortly after the war a new works was purchased at Woodley near Stockport.

Surface active agents, which were previously only marketed by the company, are now manufactured at a factory at Heaton Mersey, Stockport. Metal sequestering agents are also manufactured and Norman Evans claims to be one of the first companies to make EDTA.

Units for the manufacture of various nitrogen derivatives came into operation at the Littleborough, near Rochdale, plant of HESS PRODUCTS during 1956. Products manufactured include nitriles, amines, diamines, amides, acetate salts of amines, quaternary ammonium com-

pounds, as well as fatty acids, drying and semi-drying unsaturated acids, hardened castor oil and pitch.

ELLIS JONES AND CO. (STOCKPORT) have recently put into operation an extension of their sulphated oil plant, which, it is claimed, will enable them to increase production by 33 per cent and to deal with new types of processes.

A new building has been erected for the production of satin white pigment. The new research laboratories, which were opened about three years ago, are described as a necessary forerunner to the expansion programme.

A phthalic naphthalene plant constructed by Proabd Ltd. and Sharple Centrifuges was completed in March 1956 at the Cadishead, Manchester, works of LANCASHIRE TAR DISTILLERS. Costing £80,000, the new plant is expected ultimately to have a capacity of 6,000 tons a year.

The phenol and cresol plants at Cadishead are being enlarged. The work is due to be completed in May this year. Capacity for extraction will be increased to 1,500 tons a month at a cost of £25,000.

Rebuilding of the benzole plant, completely destroyed by fire last May, begins this May and should be finished by December 1958. The capital cost is not yet known but it is described as a 'major project.'

## Correspondence

### AUTHORS ANSWER ZDA COMMENTS ON CORROSION ARTICLE

SIR,—We regret that our remarks on the use of galvanising (page 332, *CHEMICAL AGE*, 23 February) should have disturbed the Zinc Development Association (CA, 9 March, page 418). The remark to which they refer could, if considered in isolation, be quite misleading, but in its context we submit that it is correct. In this part of our paper we are discussing methods of protecting the interior of chemical plant vessels and pipes against corrosion, and for this purpose 'galvanising and similar processes have only a limited value'. They are quite widely used for small storage vessels, drums etc. when the object is to protect the contents from contamination by iron, rather than to protect the steel from corrosion. But it is clear that this was not the problem we were discussing on P.332.

Later in our paper we stress the value of zinc coatings for protection against atmospheric corrosion, especially where corrosion is severe or repainting is difficult. Galvanising is appropriate for wire-less masts, where light sections are used and corrosion is not severe. For the heavier sections used in plant structures sprayed zinc is easier to apply, and provides a better base for painting, which is necessary to prolong the life of the zinc film in corrosive atmospheres.

We hope this statement makes it clear that our remarks were not a criticism of galvanising and similar processes in general, but only a statement, which we are convinced is true, that they have very limited application as linings for vessels or pipes in chemical plants.—Yours etc.

F. R. HIMSWORTH  
J. G. HINES

Imperial Chemical Industries Ltd.  
Billingham Division.

### 'Reeking Pipes of Non-U Science Graduates'

SIR,—I was, of course, and no doubt in common with many other readers, interested in your article on graduates' salaries and the comparison of degree in arts and science (*CHEMICAL AGE*, 23 March).

However, it seems to me that there is a conclusion to be drawn which is less baffling than at first sight. This is that the sons of well-to-do parents, having little need to train themselves for a bread-and-butter career, usually leave the Public Schools, where the accent is principally upon the academic subjects, and naturally enough choose an arts subject in which to take a degree, while passing through the university. The actual degree is of little importance, whether in law or history or Chinese metaphysics. These young men are by birth destined to lead and by privilege they do lead. The papers, including your own *CHEMICAL AGE*, are full of new directors, bearing honoured names in chemistry, appointed at an early age and well qualified in the arts faculty.

On the other hand, the scientist, quite

factually, is, more often than not, a highly informed and skilled person, smoking a reeking pipe and speaking a very slightly non-U English, graduate of a red brick university, often by grants-in-aid or by night study. I would guess that the number of Public School scientists is negligible. Those who are, are often highly successful playboys of the chemical industry.

It is for these reasons, Sir, that I suggest it to be invidious and misleading to draw comparisons between the early and ultimate salaries of arts and science graduates.

Yours faithfully,  
POLYTECHNIC.

## Royal Charter Granted to Institution of Chemical Engineers

THE Queen has approved the grant of a Royal Charter to the Institution of Chemical Engineers. A letter, signed W. G. Agnew, received by the Institution from the Privy Council Office, states:

'I am directed by the Lord President of the Council to inform you that The Queen was pleased, at the Council held by Her Majesty to-day, to approve the grant of a Charter to The Institution of Chemical Engineers.

'The Order in Council approving the draft Charter will be issued to the Home Office from which Department you will receive a communication in due course.'

The petition to the Queen for a Charter was signed by Mr. John A. Oriell, president, Sir Harold Hartley, past president, Mr. P. K. Standing, vice-president and chairman of the Institution's charter committee, Mr. F. A. Greene, hon. treasurer, Mr. F. E. Warner, joint hon. secretary, Sir Hugh Beaver, Sir Alexander Fleck, Sir Christopher Hinton, and Sir Ewart Smith.

The Institution was founded in 1922 as a qualifying professional body to organise the study of chemical engineering. At that time no universities in Britain offered courses in the subject.

Since the end of 1936 membership of the Institution has increased from 880 to the present total of 3,500. In the UK, branches operate in the Midlands and North-West. There are informal groups in Scotland, Scunthorpe and South Wales, and graduates' and students' centres exist in a number of districts, usually with a university as the focus. A strong branch exists in South Africa and advisory panels operate in Australia, India and New Zealand.

Examinations of the Institution attract entries from all over the world and are normally held in the UK, Australia, Canada, India, the Netherlands, New Zealand, Pakistan, South Africa and the West Indies.

## Management Institute Move in May

HEADQUARTERS offices of the British Institute of Management and the Institute of Industrial Administration, at present at 8 Hill Street, London W1, will be transferred this spring to 80 Fetter Lane, London EC4. The move, which is part of the scheme for re-organisation of the two bodies into one institute, will be made in the latter half of May.

Part of the new 'Management House' is being adapted to accommodate the BIM library on management and industrial subjects. A lecture room to seat 200 and smaller rooms will be available.

Lay-out of the offices in Fetter Lane will give effect to a new organisational structure resulting from the projected integration of BIM, whose membership includes some 2,000 British companies, and IIA, which has an individual membership of over 7,000. The new organisation will be known as the British Institute of Management.

Although almost half the membership of the institution works in the chemical industry, a wide distribution is to be found among a range of industries which can be singled out for their high rate of capital investment.

Figures recently released by the institution show that 14.4 per cent of its members are engaged in chemical plant manufacture, 12.2 per cent in inorganic chemicals, and 11.2 per cent in mineral oil refining (mainly petroleum), including petroleum chemicals.

## Professor Blackett Opens Instrument Exhibition

SCIENTIFIC instruments are an ideal export for the UK stated Professor P. M. S. Blackett, opening the 41st Physical Society Exhibition of Scientific Instruments and Apparatus at the Royal Horticultural Society's Old and New Halls, London SW1, on 25 March. This country, he said, had few raw materials out a great deal of technical skill.

There was no cause for complacency said Professor Blackett, who is Professor of Physics at Imperial College, London. We lived in a competitive world and would have to work hard.

The Physical Society Exhibition, which was described in last week's issue of *CHEMICAL AGE* (p. 501) was open from 25 to 28 March.

## Radioactive Technique for Studying Effluent Effects

Wilton works of ICI Ltd., are to employ a radioactive tracer technique to investigate the concentration of effluent in the estuary waters of the Tees. ICI will be assisted by the Atomic Energy Research Establishment, Harwell, in ensuring that no danger arises from the use of radioactive material, while a watch is kept on the effect of the effluent on conditions in the estuary.

## BROTHERTON REORGANISATION SUBJECT OF MANAGEMENT INSTITUTE PAPER

CHANGES in policy and organisation that followed when Brotherton and Co. Ltd., chemical manufacturers, Leeds, was converted into a public company eight years ago, were the subject of a paper given by Mr. W. F. Dunnett, financial director, at a British Institute of Management conference held at Southampton from 22 to 24 March.

Before the change the duties of the directors had been to advise and carry out the policy of one man to whom alone they were responsible. Overnight they became accountable to a large body of shareholders and had to shoulder the wider responsibilities that existence as a public company entailed.

The directors, who decided that a radical overhaul was necessary, saw that the strength of the company lay in a strongly established business within defined groups of chemicals; five factories and a central research laboratory; established markets for all products at home and for some products in practically all countries outside the Soviet bloc; and substantial capital reserves.

Mr. Dunnett summarised weaknesses of the company as a dispersed organisational structure, particularly weak on the sales and production sides, and without the right kind of statistics needed to develop and guide the board's policy. A firm of management consultants was brought in and they established the necessity for basing the reorganisation on a number of definite principles.

### Executive Direction

The first was that organisational structure had to ensure that each major function was directed and controlled by an executive director, backed up by a strong executive team; close control of a planned production programme, co-ordinated with marketing, production, cost data and company policy; sales had to be provided with full information and facts on marketing potential of products and applications, existing and potential customers; a force of representatives and service technologists was called for; production had to be able to provide plant and technical capacity with minimum delay both for greater output and for production of new products; budgetary control was essential on the financial side.

Many of the functions implicit in these principles had been carried out for a long time. They provided the basis for the reorganisation. The major features of the structure include that of a deputy chairman functioning as the co-ordinating and chief executive director; each division—commercial, financial, production, research and development—is controlled by an executive director with no other functional responsibility.

For the first time, the production function and its ancillary services were conceived as being a single unit within the larger structure of the company. A central engineering plant was established to obtain the full benefits of facilities and

capacity for handling projects efficiently; and preventive maintenance methods, including work study, to keep plant and buildings in sound condition at minimum cost.

In the research and development unit, the development function and that of pure research were combined and the unit placed under the control of a technical director. Three internal sections were established, handling respectively: development; research on new products; process research and analytical chemistry.

Statements of responsibilities for each key executive and 'third line' employee stated his place in the organisation, his responsibilities, and to whom he was responsible and whom he controlled.

## Poland Plans Pure Sulphur Capacity of 100,000 Tons a Year by 1961

PLANS for the exploitation of the large sulphur deposits discovered in Poland some years ago were described by the director of the Central Bureau for Mining of Chemical Raw Materials in an interview published in *Zycie Warszawy*.

Geologists estimate the amount of sulphur in the Tarnobrzeg, Piaseczno and Szydlow areas as over 95 million tons of the pure element (Mexico's deposits amount to 111 million tons, those of the US to 90 million, of the USSR 70 million, and of Italy 30 million). The deposits so far known lie on the northern edge of the sub-Carpathian miocene sea. The largest beds are in the fork of the Vistula and San Rivers in the Tarnobrzeg regions and a big sulphur combine is planned here for the near future.

### Sulphur Content High

The Tarnobrzeg sulphur lies at a depth of 60 to 80 metres; mean thickness of the seams is 10 metres and the sulphur content averages 29 per cent. Seams in other regions lie nearer the surface (15 to 45 metres) but are thinner and the ore is less rich.

Hydrological conditions present the biggest problem in exploitation. The sulphur bearing strata are saturated and the water is strongly impregnated with hydrogen sulphide (120 to 320 mg. per litre). Extensive pumping will be necessary as well as stringent purification of the effluent before allowing it to enter the Vistula.

The Tarnobrzeg combine will consist of a large open mine, plant for concentrating ore (flotation and refining), a power station, plant for purifying water, sulphuric acid plant, and, to utilise waste materials from the flotation process, a cement works. A settlement for about 2,000 families will be built on the site.

In July 1956 work began on an experimental mine in the Piaseczno region. So far 35,000 cu. metres of earth have been moved and 20 million cu. metres of

## Wage Talks Postponed Until 3 April

MEETING of the Joint Industrial Council for the chemical industry, scheduled for 26 March has been postponed to 3 April. The Association of Chemical and Allied Employers will then reply to the unions' request to reconsider its rejection of the pay claim on behalf of 70,000 workers in the industry.

Imperial Chemical Industries Ltd., have also been asked to reconsider their original refusal of the claim, which was for a 'substantial' increase for its 80,000 wage-earning employees.

Similar claims are in negotiation for 45,000 workers in the drug and fine chemical industry. Wages of engineers employed in the chemical industry will be discussed by employers' and union representatives on 8 April.

water pumped out. The first seams of sulphur are expected to be reached in the next few months. Towards the end of the year this experimental working will be transformed into an experimental mine which before the year's end should yield a small quantity of sulphur ore for experimental work on a semi-industrial scale (mainly on ore concentration and refinement of sulphur).

In 1958 production of Polish sulphur is expected to be 55,000 tons of ore, from which 10,000 tons of the pure element should be obtained. In the two succeeding years, production of pure sulphur should rise to 30,000 tons a year.

In 1961, the first part of the Tarnobrzeg combine should come into operation, and from then on an annual production of 100,000 tons of pure sulphur is expected.

The building of four sulphur mines is envisaged in 1970, which should make it possible to obtain over a million tons of pure sulphur annually. It will consequently be necessary to invest in more processing plant and new railway links.

In planning the Tarnobrzeg combine there has been close Russo-Polish collaboration. Co-operation with Czechoslovakia is also anticipated, and talks took place on the question of joint Polish-Czech exploitation of Polish sulphur earlier this month.

### Potash Imports Monopoly

UK imports of potash from France, West Germany and Spain have been in the hands of a single company, said Sir David Eccles, President of the Board of Trade, in the House of Commons last week. He was asked to name the countries in Europe from which potash exports to the UK were covered by cartel arrangements and in his reply he said that the present Monopolies Commission inquiry into the supply of chemical fertilisers would no doubt give additional information.



# ANGLO-US LINK ON BASIC INDUSTRIAL RESEARCH PROJECT

## New Institute Expected to Publish Significant Findings on Suchochemistry

**A** LINK between research workers in America and Europe was provided by the Arthur D. Little Research Institute at Inveresk, near Edinburgh, said Lord Strathclyde, Minister of State for Scotland, when he inaugurated the institute on 22 March.

Among the first projects to be undertaken at the institute are investigations into the production of flexible plastics from petroleum, and into sugar chemistry. It is also proposed that the new institute should study the chemistry of corrosion.

Describing the institute as the first sponsored research organisation of its kind in the world, Lord Strathclyde announced that it would undertake fundamental research 'for its own sake'. Results of that research would, he added, be published.

Under the joint auspices of Arthur D. Little Inc., Cambridge, Mass., US, and a number of prominent individuals in this country interested in the furtherance of international scientific relations, the Arthur D. Little Research Institute has been set up, with the approval of the Government, in the laboratories occupied during the last 10 years by the Institute of Seaweed Research.

### Marine Algae

Since 1944 the Scottish Seaweed Research Association, which later became the Institute of Seaweed Research, has been working on scientific problems associated with marine algae and their utilisation. This work has aided the development in this country of a new industry, based upon seaweed, and now using annually more than 40,000 tons of this indigenous raw material which, until recently, was regarded as useless.

Work on seaweed, financed by the Development Commission, is being continued on a reduced scale at the Institute of Seaweed Research. This will be independent of the new institute and its main responsibilities will be to support fundamental research at the universities, to operate an information service particularly for the use of Scottish industry, and to give technical assistance and advice to those interested in seaweed utilisation in the crofting communities.

The new research institute is thought to be unique in its conception and mode of operation. Fundamental studies in different scientific fields will be undertaken by teams, each consisting of about four scientists with appropriate technical assistance. In each case, the leader of the team will be a specialist in that particular line of research. At the outset it is planned to have four to six such teams on work of a fundamental character and

not concerned with any specific or immediate commercial objectives.

**Projects already in train are concerned with a basic study of linear polymers, including an investigation of their mechanism, kinetics and properties, and the chemistry of the sodium succrates and their derivatives.**

Financial support for these studies is being provided initially by a number of US organisations co-operating with Arthur D. Little but projects are open to British and continental sponsorship on exactly comparable terms. The direction of the institute and the majority of its staff are British but it is intended to give an international quality to its operations by engaging highly qualified scientists from the Continent. Members of the scientific staff will be free to publish their findings.

Lord Bilsland is chairman of the board of management of the new institute. The other British members of the board are Sir Robert Erskine-Hill, Sir David Anderson, director of the Royal College of Science and Technology, Glasgow, and Sir Ian Heilbron, director of the Brewing Industry Research Foundation, Nutfield, Surrey, and Professor Emeritus of Organic Chemistry, University of London. The American members are Mr. Raymond Stevens, president, Arthur D. Little Inc., and Dr. L. W. Bass and Mr. W. A. W. Krebs, vice-presidents. Dr. F. N. Woodward, C.B.E., F.R.S.E., who has been director of the Institute of Seaweed Research almost since its inception and previously Scientific Attache at the British Embassy, Washington, DC, is directing operations.

### Did Not Make Sense

Mr. Raymond Stevens, president, Arthur D. Little Inc., proposing a toast, 'International scientific relations', at a lunch following the inauguration, said his organisation had studied several patterns of operation. 'As you know, science is now international and we could not continue to maintain an organisation of our type and scope properly without being participants in, or at least in reasonably close touch with, the pursuit of science in Britain and the Continent', declared Mr. Stevens. 'Several plans were proposed to me and strongly urged. Some of them have been tried by other organisations. A plan based on normal applied research on an economy foundation did not seem to me to make sense. Realistically, I could see no commercial sense in attempting to profit by the salary differentials of applied research, nor has such information as I have obtained on other attempts changed this view.'

'Again, I had no interest in a staff en-

gaged primarily in travelling among universities and the research laboratories with the purpose of reporting back what would not otherwise reach their companies. Before the war various representatives carried out this procedure but in my opinion, at least so far as our organisation is concerned, that day is past. A direct and open relationship in specific instances, for our purpose at least, seems preferable.

'But', continued Mr. Stevens, 'Britain and the Continent had one asset in which they were outstanding—they were known as a proper setting for basic, fundamental, uninhibited, pure science research. Unfortunately, only a few and an extremely limited number of very large companies in the States could afford to establish fundamental research centres here, even if they had the vision for such a project.'

'The Arthur D. Little organisation is fortunate in having friends in industry, research associations and foundations who see the need for fundamental research. We saw here an opportunity to render a mutually advantageous service by bringing together a number of potential sources of support for a non-profit organisation.'

There was widespread comment in the US on the need for more support for fundamental research—but there was too little action, said Mr. Stevens. 'I am not at all sure that it is only in the States that this is true—but we do hope to establish a pattern for action and in a way that will benefit all concerned.'

**He added that he was pleased with the start that had been made. One of the projects—that supported by the Sugar Research Foundation—had already made progress that may lead to an early publication of scientific findings of significance. This work was under the general direction of Dr. Woodward and the more direct leadership of Dr. Black.**

### Duties to be Established Under the Common Market

THE COMMON MARKET treaty was signed in Rome on Monday this week. It provides that negotiations will begin within two years to fix the duties on outstanding items. Most tariff duty rates against external goods have been fixed and they mainly involve raising the Benelux and West German rates and lowering the French duties.

Duty-free products included kaolin, selenium, unprepared beeswax, vegetable waxes, natural magnesium carbonate, crude vegetable oils, nickel and intermediates, tin, copper and copper alloys.

Duties include: 5 per cent, carbon black; 15 per cent, phosphorus, titanium oxide and titanium white; 8 per cent, naphthalene and tertiary butyl alcohol; 10 per cent, oxides and hydroxides of iron, potassium and sodium chlorates; 3 per cent, crude phenols, xylenols and cresols.

### Parent Company to Control Sales

From 1 April the products of Menley and James and Smith Kline and French will be sold through the parent company, Smith Kline and French Laboratories Ltd., 120 Coldharbour Lane, London SE5 (Brixton 7722).

## Fixation of Fission Products in Montmorillonite Clay

**D**ISPOSAL of long-lived fission products' was the subject of a paper presented by Mr. J. R. Grover at a meeting of the North-Western branch, Institution of Chemical Engineers, held in Manchester on 14 March.

Fission products are formed by splitting uranium atoms to liberate energy in the form of heat for power and the fission products must be removed periodically from the fuel. Fission products are radioactive and have half-lives from milliseconds to millions of years. Of the fissile materials, strontium 90 and caesium 137 have half-lives at least ten times those of the other isotopes and the former is 25 times as toxic as any other isotope emitting  $\beta$  particles; therefore it is important to isolate it to render easier the disposal of the other fission products. There may be a use for Cs 137 but Sr 90 must be stored safely for years.

The fission products are formed into stable solids and the methods include the preparation of concrete from liquid wastes, the fusion of wastes in glass and in ceramics and the fixation of the waste in montmorillonite clay.

Montmorillonite clay is easily available, inexpensive and stable; it has ion exchange properties and its structure is changed by heating it to about 1,200°C when the product loses its ion exchange properties and fuses to a glass. For the fixation work, the clay was bonded with hydrolysed ethyl silicate and heated to such a temperature that firm granules were formed. Two columns of granules were placed in series and the radio-active solution at 70°C passed upwards through them until the first column was saturated;

then the excess solution in the first column was washed into the second column by water, the second column being at about 40 per cent of its capacity; then both columns were drained. The first column was dried by hot air, fired to about 1,200°C and removed for disposal; the second column is placed in the position of the first column and a new second column is used.

The pilot plant is operated by remote control. The granulated clay is placed in a canister outside the radio-active area, transported to the active area for ion exchange and firing, then stored as a radio-active material. The canister is a 6-in. nominal bore m.s. tube, 3 feet long, with machined end-pieces. The contents are fired electrically by heating spirals which are located in the clay, the temperature is measured by thermo-couples and welded joints are used. The water of the solution is decomposed by the radio-active materials, therefore the solutions are passed upwards through the granules to disengage the gas from the granules more readily than a downward flow.

An overhead trolley moves the canisters and details of the drive and an indicator for its position were described together with many mechanical details for the remote control and the operation of the pilot plant. The canisters were insulated during firing by firebrick and kieselguhr powder. Stainless steel pipework was used and no pockets of liquid could be trapped in the bends. The clay was dried by air at 400°C, the water in the used air was condensed and led to a delay tank while the air was passed through a filter before venting it to the atmosphere.

## Third International Instrument Show

OVER 50 manufacturers from six countries were exhibiting at the Third International Instrument Show, Caxton Hall, London SW1, from 25 to 29 March.

Organised by B and K Laboratories Ltd., 57 Union Street, London SE1, the show was devoted to electronic instruments of every variety, ranging from pH meters to microwave therapy equipment.

A transistorised scintillation counter was shown by Universal Atomics Corporation of the US. It is claimed that this instrument enables operators to determine different energy levels such as those emanating from radium and cobalt or iodine and chromium.

Titration apparatus was shown by Metrohm AG of Switzerland. Model E298 is a motor driven piston burette with two adjustable speeds. The motor runs as long as the button is pressed. The burette can also add the reagent in equal steps of one per cent of the total volume.

Cambridge Instrument Co. of the UK showed a direct reading pH indicator which covers the range 0 to 14 pH to an accuracy of 0.05.

## Chemical Plant in Hand by Power-Gas

OPPORTUNITIES of the chemical plant division of the Power-Gas Corporation Ltd. in large-scale chemical engineering are continually being widened and supplemented by licences to use processes developed by others. An example is the Texaco partial oxidation process for the production of gases used in the chemical industry.

This was stated by Major W. R. Brown, chairman, at the 57th annual meeting last week. He mentioned that among projects in hand was a synthesis gas plant for the production of nitrogen fertilisers. During the year, the division's Krystal crystalliser business had seen five plants built and contracts received for three more, including a 900-ton-a-day ammonium sulphate crystalliser plant in Italy.

The division's first sulphuric acid plant to Chemiebau Zieren design had successfully passed its demonstration tests. Two plants for the production of pure hydrogen from propane and butane gases were under construction and three plants employing the Girbotol process were nearing completion.

## Geigy Raise Prices

Owing to the rapid rise in the cost of castor oil. The Geigy Co. Ltd., Rhodes, Middleton, Manchester, have increased prices for sebacic acid and Reomol sebacate plasticisers, which are derivatives of sebacic acid, as from 26 March.

Price of sebacic acid has been increased by 4d a lb. throughout the scale. Those esters which require approximately  $\frac{1}{2}$  lb. sebacic acid per lb. of finished ester have, therefore, been advanced 2d a lb. These esters are Reomols D79S, D10S, DOS and DNS. Reomol DBS, which requires more than half its weight of sebacic acid, has been increased by 2½d a lb. throughout the scale.

## NRDC Finance Frozen Milk Project and Continue Acetylene Synthesis Works

A METHOD of preparing a frozen milk which can be stored for at least 12 months without deterioration is one of the new development projects of the National Institute for Research in Dairying. This is stated in the annual report of the National Research Development Corporation, which financially support the work.

Pasteurised milk is treated with ultrasonic waves, poured into polythene bags and quickly frozen in a brine bath. The Corporation, to whom the patent rights have been transferred, has licensed two British firms who expect to go into production shortly. This development will enable fresh milk to be provided on long sea voyages, the storage of milk during times of over-production and shipment to countries where good quality fresh milk is unobtainable.

Reporting on the acetylene synthesis project at Imperial College, NRDC say this is a long-term project. Burners under various conditions of preheat have been studied in a preliminary way. The Corporation is still only at the stage of determining the criteria for a good burner. The next stage, to couple the burners to

a gas turbine with all its attendant difficulties, must wait until the design study of the burners is complete.

Other projects under review include an ion exchange process for a natural product; pesticidal coating composition; liquid gases plant; Sir Thomas Merton's diffraction grating inventions; Dr. Pontecorvo's synthesis of new strains of micro-organisms.

Latest list of licensed inventions being exploited by industry on a scale which provides the Corporation with significant revenue include the following: hecogenin production from sisal; MoS insecticidal bomb filled with a heat-sensitive insecticidal or larvicidal controlling substance which is arranged to be vaporised by an ignitable material contained in the bomb; and Professor R. L. Wain's discovery that the properties of certain phenoxybutyric acid derivatives and other compounds, while acting as powerful 'hormone' weed-killers, were found to be non-toxic to valuable crops such as clover, hitherto sensitive to weedkillers of this type—licences have been granted to a number of firms.

## Overseas News

### UPGRADING OF ISRAEL'S ROCK PHOSPHATE TO BE STUDIED BY NEW UN COMMITTEE

UNITED Nations sponsored technological advisory committee, headed by Sir Benjamin Lockspeiser, president of Euratom and former director of the Department of Scientific and Industrial Research, has been set up to advise the Israeli Government on the best and speediest development of Israel's economy. Consisting of six foreign and 10 Israeli experts, it will meet three to four times a year.

Among projects to be submitted to the committee are: Studies on methods for upgrading rock phosphate with the aim of increasing the content to 34 per cent; extraction of magnesium from the Dead Sea; large-scale increase of the quantity of potash extracted from the Dead Sea.

Small quantities of uranium now being produced as a by-product of phosphate fertiliser production, are said to be sufficient for atomic research which is in the pilot plant stage.

#### Magnetite in El Salvador

German scientists are reported to have discovered large deposits of Magnetite in El Salvador, which could be exploited for at least 10 years. The Government is studying the establishment of a plant to develop them.

#### Panama Refinery Planned

Plans for a refinery to be constructed by the Panama Refinery Co., (Refineria Panama SA) will be ready shortly and preliminary site preparation and construction work will be completed during the coming dry season. In the following year, the refinery will be constructed. This refinery is designed to supply raw materials for the local production of chemicals for agriculture and the manufacture of plastics from its by-products.

#### German Phosphorus Furnace Now Working to Capacity

Knapsack-Greisheim's second phosphorus furnace, which was commissioned in October last, is working to full capacity. It is rated at 46 megawatts and is said to be the largest at present in the world.

Knapsack-Griesheim AG now dispose of annual capacity for 35,000 tons of yellow phosphorus which is equivalent to British installed capacity. Whereas, before commissioning the new furnace, elementary phosphorus was imported continually from the US, Canada, England and France, Knapsack's capacity is now sufficient to meet West German requirements for some years and to allow for exports to neighbouring countries.

In 1956, the company also brought into

service a new oxidation tower for manufacture of phosphoric acid and a new phosphates plant which works by a process devised at Knapsack.

#### Nylon Finish for Cottons

Nylon is being applied to cotton garments as a finish produced from nylon flake in solution. The finish is applied on top of resin finishes. The nylon flake is being made by Belding Corticelli Industries, US, under licence from E. I. du Pont and Nemours Co., Inc. who have developed this process.

Glazing cotton with nylon is said to increase the tensile strength of the fabric, to produce a silkier finish and to increase resistance to creasing.

#### New Source of Water Gas in Holland

A new process for the conversion under pressure of oil into water gas has been developed by BPM. in The Hague. Hitherto, coke and coal have been essential for the production of water gas in Europe. The process is stated to be both flexible and economical, and any hydrocarbon, ranging from gas to heavy oil, can be used. The first commercial unit came into operation at Ijmuiden last December. (A £6 million fertiliser plant under construction at Shell Haven is also scheduled to manufacture water gas by the same process).

#### Allied Chemical 1956 Results

Net profit in 1956 of Allied Chemical and Dye, US, it is noted, equalled \$4.74 (\$5.28) per share. Total sales rose by 6 per cent. The company is hoping for some degree of recovery in basic nitrogen fertiliser business.

#### US Chemical Industry Urged to Overcome Manpower Shortage

Members of the American Institute of Chemical Engineers were told, at their recent White Sulphur Springs meeting, that the continued emphasis on research and development and the greater complexity of chemical products and processes were expected to lead to disproportionately rapid increases in demands for chemists, chemical engineers and technicians by 1956, at least.

Mrs. A. J. Wickens, a US Labour Department official, said this would necessitate the industry's taking into account the change in American manpower trends in the coming years. Of an expected increase of 10 million in the

number of workers, about 5 million would be men, half of whom would be under 24 years of age. If it expected to tap this inexperienced manpower pool, the chemical industry would have to place greater emphasis on testing, placement and on-the-job training.

The industry was also urged to consider adjusting retirement schemes for older workers who would be on the increase during the 10 year period, and to consider opening up new areas of employment for women, since they would constitute about half of the labour force increase in the next 10 years.

#### New Chemical Factories for Naples Province

With financial support of the Banco di Napoli (250 million lire) Industria Chimica del Mezzogiorno of Florence have set up a factory in Naples for the production, regeneration and use of sulphuric acid.

Similarly, Resia (Resin Sintetiche ed Affini) with a 200 million lire loan from the Banco di Napoli, have built a factory at Casoria for the production of synthetic resin.

MMM Triemme have obtained credit from the Isevirme for building a factory in Naples for the production of decorative laminates, insulating varnish and formaldehyde.

With a loan of 800 million lire, Rhodiatocce S.p.a., Milan, have been building a factory in the Comune of Casoria for the production of nylon.

#### Polyester Fibre for Japan

It has now been announced by the Japanese Ministry of Trade that \$500,000 will be allocated for the import of 180,000 lb. of polyester fibre (Terylene) filament and staple from the sterling area, mostly from Britain.

#### Uses for Persia's Natural Gas Studied

US consultants, Lilienthal and Clapp, who have been made responsible for planning the development of Khuristan, Persia, are reported to have asked Montecatini, Italy, to study the possible uses of natural gas in the area. These studies will have to be considered in relation to those of Union Chimique Belge, Belgium, who are dealing with the possible setting up of a fertiliser factory using natural gas.

#### Nuclear Research Centre in New Jersey, US

A nuclear research centre to study the application of radiation to petroleum technology is to be constructed by Socony Mobil Oil Co. Inc., near Princeton, New Jersey, US. Construction is expected to start this summer.

It will be operated as a subdivision of the Socony Mobil Research and Development Laboratory at Paulsboro, NJ, and will contain a 2,000,000-electron-volt Van de Graaff accelerator, a 'hot' laboratory equipped for manipulation of fission-waste radioisotopes, and 'counting' laboratories for assaying radioactive materials. Nuclear physics and radiation

chemistry investigations will be undertaken.

First Van de Graaff accelerator to be used in the petroleum industry, a 'baby atom smasher' of 500,000 electron volts, was installed in 1953 at the Field Research Laboratories in Dallas, Texas, of the Magnolia Petroleum Co., a Socony Mobil affiliate. This, and a 2,000,000 volt accelerator added last year, have been employed mainly in research on crude oil exploration and production. The new 2,000,000-volt accelerator at Princeton will enable Socony Mobil to broaden the scope of its nuclear research programme.

### Sicilian Fertiliser Plant

It is reported that Sincat, of the Edison Group, are to build a fertiliser plant in Sicily at Syracuse.

### New Calcium Carbide Plant for Israel

Mayer Investment Corporation, an Israeli-Swiss group, has a £200,000 calcium carbide plant under construction near Tel Aviv, which will be ready to start operations by November. Capacity will be 4,000 tons a year, of which about 75 per cent is ear-marked for the home market. Equipment is on order from Switzerland, Italy and West Germany.

### Japan Plans Production of an Acrylo-nitrile Fibre

Production of an acrylo-nitrile staple fibre, X-54 Exlan, is planned for next month by the Japan Exlan Industrial Co., which was set up jointly by the Toyo Spinning Co., and the Sumitomo Chemical Industry Co. last September. One ton a day will be produced initially, but the company hopes to expand its output in March 1958 to seven and a half tons a day when its own factory at Saidaiji in Western Japan has been completed. By March 1959, the company plans to produce 15 tons daily and 30 tons a day by March 1960.

### Indian Subsidy for Detoluenated Benzol

The subsidy (one anna per gallon) on detoluenated benzol sold as motor benzol to be used as an admixture with petrol is to be continued for one further year, the Government of India has announced. It will be paid to those manufacturers who have installed or made arrangements to install scrubbing equipment to produce crude benzol from their coke ovens as well as the requisite plant for further distillation of crude benzol into benzene, toluene, xylene and other products.

### Expansion to Liljeholmens' Stockholm Plant

Fatty acid nitrogen derivatives plant of Liljeholmens Stearinfabriks Akt, Stockholm, is being expanded and production increased to meet rising demand. These materials are used as intermediates in the chemical industry; allied industries served include, cosmetic, food, pharmaceutical, metallurgical, ore flotation, paper, petroleum, lubricating oil, plastics, printing ink, road building, rubber, surface coating and

textile. In addition, Liljeholmens produce corrosion inhibitors for use in steam plant systems.

A revised edition of the company's booklet 'An introduction to amides, nitriles, amines and quaternary ammonium salts, their properties and applications' has been produced and is obtainable free from the sole UK selling agents, Guest Industrials Ltd., 81 Gracechurch Street, London EC3.

### New Curing Agent for Epoxy Resins

DDS (4,4'-diaminodiphenylsulphone), until now used for the treatment of leprosy, has been found to improve the high temperature performance of epoxy resins cured with it. Merck and Co., US, are now expanding production of this compound.

### ACS Establish Division of Inorganic Chemistry

The newly formed division of inorganic chemistry of the American Chemical Society is seeking more members among scientists both in and outside the US who are interested in inorganic chemistry. The membership dues of \$3.00 per year may be sent to Dr. L. B. Asprey, Los Alamos Scientific Laboratory, Box 1663, Los Alamos, New Mexico.

The division is offering its first programme of symposia, general papers, and social events at the society's national meeting in Miami, Florida, beginning 7 April 1957. Included are symposia on 'The present status of inorganic chemistry' and 'Unfamiliar oxidation states of the elements'.

### ICI to Open Polythene Plant in Australia

A plant for the production of polythene is to be opened by ICI of Australia and New Zealand at Sydney late this year. The new factory, to cost A£1½ million will save Australia A£1 million a year in imports. This was announced this week by Mr. J. C. Swallow, chairman of the ICI plastics division in the UK, at the first conference of the Plastics Institute in Australia.

### Lebanon Tariff Changes

Chloride of magnesium, calcium and barium have been exempted from import duty in the Lebanese customs tariff. Other salts of hydrochloric acid are chargeable at 11 per cent, *ad valorem*.

### S. African Uranium Exports

Exports of prescribed materials (uranium and thorium) from South Africa in January totalled £3,268,721, against £2,936,545 in January 1956, according to a preliminary estimate by the South African Excise and Customs Department.

### Du Pont Re-name Division

A new and more accurately descriptive name—Freon products division—will be used after 1 April 1957 to identify the division of Du Pont's organic chemicals department concerned with manufacture and sale of fluorinated hydrocarbon retri-

gerants, aerosol propellents, solvents, and fire extinguishing agents.

The change drops the Du Pont designation of kinetic chemicals division, under which the Freon compounds have been made and sold since mid-1950, when Du Pont acquired all the assets of the 20-year-old firm, Kinetic Chemicals Inc.

### Production Increases in Indian Chemical Industry

From New Delhi it is reported that India's production of soda ash, caustic soda and liquid chlorine is to be increased nearly four-fold during the Second Five-Year Plan. Production of soda ash is expected to increase from 77,270 tons in 1955 to 250,000 to 300,000 tons in 1961. Output of caustic soda will increase to 200,000 tons from 34,250 tons in 1955 and liquid chlorine from 14,580 tons in 1955 to 250,000 tons in 1961.

### Teflon Rod Price Reductions

Price reductions of up to 30 per cent are announced in a bulletin issued by Tri-Point Plastics Inc., Albertson, N.Y. Expansion of extruded TSI Teflon rod to include 40 'in stock' diameters is also announced in the bulletin. The bulletin, T-257-R, contains information on properties, specifications and prices.

### Large Natural Gas Find in Quebec

Geologists of the Quebec Government have confirmed the first large commercial natural gas find in Quebec. The well was drilled by Bald Mountain Oil which holds a 373,200-acre concession extending along the north shore of the St. Lawrence River. Natural gas was first struck at 2,194 feet. Initial tests indicated a flow of 357,000 cubic feet per day.

### Dechema Issue Chemical Production Flow Sheets

The series of leaflets dealing with chemical production flow sheets, and plant diagrams first issued in 1949 by DECHEMA (Deutsche Gesellschaft für chemisches Apparatewesen, Frankfurt, Rheingau-Alle 25, Frankfurt), have now been revised and enlarged. The new set comprises 40 sheets and contains 220 diagrams representing the types of equipment most commonly used in chemical technology. Price is DM 16.

### US Tall Oil Output A Record in 1956

Available whole (crude) tall oil supplies in the US reached a record of more than 300,000 tons last year, exceeding the previous record by 5 per cent. This was stated at the recent annual meeting of the US Pulp Chemicals Association. The PCA sulphate turpentine division is developing a programme to stimulate knowledge of and greater use for sulphate wood turpentine.

### Dominion Tar Profits Up

Consolidated net profit of the Dominion Tar and Chemical Co. for 1956 was \$4,915,609 (\$3,801,852). Sales showed an increase of 11 per cent over the previous year.

# Synthetic Rubber Symposium Opened in London

## World's Growing Demand for Rubber

**F**IRST International Synthetic Rubber Symposium, which was held at Church House, Westminster, London SW1, from 26 to 28 March, was opened by Sir David Eccles, President of the Board of Trade. He was welcomed by the symposium chairman, Mr. G. E. Beharrel, F.I.R.I., chairman, International Synthetic Rubber Co. Ltd., and deputy chairman and managing director, Dunlop Rubber Co. Ltd.

Mr. Beharrel extended a cordial welcome to visitors, many of whom had come from overseas, and congratulated the organisers, *The Rubber and Plastics Age*, for arranging the symposium.

Mr. Beharrel remarked that rubber in all forms was now so common place that it was easy to forget how modern the industry was. In the lifetime of many present the total annual supply of rubber to the world had been a mere 53,000 tons.

Prior to the second world war, the art of converting rubber into manufactured articles was locked up in zealously guarded secret processes. In the last 30 years, the output per man in the tyre industry had, as a result of technical developments and improved methods, increased four-fold. Quality had made even greater progress and a modern tyre now had a wear factor 40 times greater than the product of 1918.

### Changes Reflected

The symposium, Mr. Beharrel said, would reflect some of the changes which had taken place in recent years. The industry now had a wide range of synthetic rubbers and other materials at its disposal, most of them designed to give specific properties to the finished products. While special compounding ingredients and processes for vulcanisation or cross-linking had been evolved and new chemical materials to improve resistance to atmospheric conditions. The line of demarcation between the rubber and plastics industries was narrowing and was becoming less well defined by the introduction of borderline synthetic materials.

It was idle, Mr. Beharrel pointed out, to assume that synthetic rubber developments had reached finality. In fact, recent advances in polymer chemistry suggested that it was only at the beginning and this emphasised the great dependence of the industry on science and technology.

Some idea of the rubber industry's growth and the increasing utilisation of synthetic raw materials could be obtained by comparing consumption of natural rubbers and synthetic rubbers over the last 20 years. In 1936, world consumption of rubber was 1,450,000 tons, practically all of which was natural rubber. In 1956, total consumption exceeded 3,000,000 tons of which 1,850,000 tons

was natural rubber and the remainder (40 per cent) synthetic.

Mr. Beharrel went on to say there was some justification for assuming that the total demand for rubber 10 years hence would exceed 4 million tons a year. There was consequently a challenge to both the natural rubber grower and the synthetic rubber producer with great opportunities for both. The advances in the synthetic field, he stressed, did not mean that the plantation industry was likely to experience a progressive recession in the foreseeable future. Modern science and technology would not only be applied to improve and develop synthetic rubber but they would also be applied to improve uniformity or quality of natural rubber while biochemical science would assist in promoting earlier maturity of rubber trees and increase latex yields.

Sir David Eccles, opening the first symposium, said that the Government welcomed the production of synthetic rubber in Britain provided it received no protection either from synthetic rubber produced abroad or from plantation rubber.

He did not believe that there was a 'great conflict between the natural and synthetic products' which had been suggested. He added that healthy competition between natural and synthetic rubbers was in the true interests of everyone.

Professor Paul Baumann, president of the executive committee, Chemische Werke Hüls AG, stated in his paper read at the symposium that in Western Germany a new synthetic rubber plant will be erected. Butadiene will be produced from n-butane and styrene will

be delivered from Chemische Werke Hüls AG. The dehydrogenation of n-butane to butadiene will be made by the Houdry process. The dilute butadiene obtained by this process will be concentrated by the copper ammonia acetate extraction process of Esso Research and Engineering Co. In total, 38,000 tons per year of butadiene will be manufactured; 6,000 tons will be available for other tasks. The butadiene concentration capacity will be such as to include purification of all the recycle butadiene from polymerisation.

Polymerisation will be carried through in 5,300 gallon agitators using a Redox system for the catalysis. The polymerisation plant will be subdivided in two polymerisation batteries with subsequent coagulating and drying equipment. The plant will manufacture 45,000 tons per year of Buna Hüls K, i.e. cold rubber which is a butadiene styrene copolymer produced at 41°F with Redox system and moderators.

### New Polythene Tube Factory

Mange Plastics Ltd., a Tube Investments subsidiary will shortly open a new factory at Aston, Birmingham where the major part of its production will be centred. At present mainly concerned with the manufacture of TI polythene tubing, the company also specialises in the fabrication of welded plastic pipe structure for corrosive liquids and gases. Capacity will be trebled by the new works.

### Six Men Hurt in Explosion

Six men were burned—three of them severely—when they were removing a tubular heater from a reboiler on the tar acid distillation plant recently at the Bolsover works of British Diesel Oil and Petrol Co. Ltd. (subsidiary of Coalite and Chemical Products Ltd.). The heater was half-way out of its setting when the explosion occurred. The men were working on a fractionating column, about 35 ft. above ground.

## Romford Chemical Engineers Expand

A NEW WING to their design and engineering offices at Harold Hill, Romford, Essex, has been added by W. J. Fraser and Co. Ltd., chemical engineering contractors. The new building accommodates the operations, purchasing, inspection and chemical engineering departments. This leaves more room in the

main building for the drawing offices.

The firm now employs nearly twice as many draughtsmen and designers as in 1953, when the offices were built.

The new building is part of an expansion programme which includes the experimental building, for pilot-scale process testing, recently put into operation.

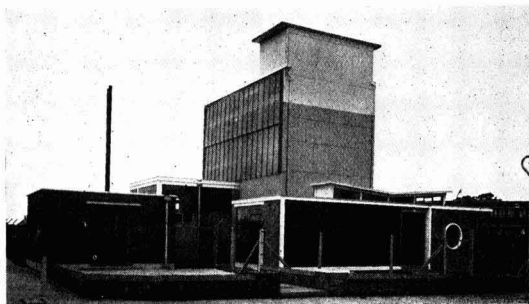

W. J. Fraser's experimental building for pilot-scale testing.

## Chemist's Bookshelf

### A GUIDE TO ANALYSIS

A GUIDE TO QUALITATIVE ORGANIC CHEMICAL ANALYSIS. By R. P. Linstead and B. C. L. Weedon. Butterworths Scientific Publications, London. Academic Press Inc., New York, 1956. Pp. xi+169. 21s.

This up-to-date text is the outcome of a course of instruction given to students at the Imperial College of Science and Technology, University of London, for more than 25 years. It is suitable for first and second year students reading an honours degree course or the graduate membership examinations of The Royal Institute of Chemistry. The authors have departed from conventional systems of analysis based on the melting point of the compound and its solubility in various media.

Emphasis has been placed throughout on functional group identification after the constituent elements have been ascertained. Characterisation of the compound is accomplished by the preparation of a suitable choice of derivatives. This modern approach raises the subject above that of tedious routine and affords the student an opportunity to exercise his powers of experimental observation and deductive reasoning.

Treatment is simple, but it includes much advanced material of interest to postgraduate students and chemists engaged in industrial research who are frequently required to find reliable

methods for identifying unknown and new organic compounds. The chief merit of this book is the choice of characterisation tests compiled from standard reference works and current research literature. The reactions selected have been well tried out and are sufficiently general to constitute a useful guide to more advanced and complicated circumstances.

Although many of the reactions described involve the use of very small quantities of reagents and reactants, no descriptions of micro or semi-micro manipulative techniques are given. The authors, in their preface, mention that this is best taught by practical demonstration. Alkaloids, steroids, organo-phosphorus, organo-fluorine, and many heterocyclic compounds are not discussed.

The final chapter deals very briefly with methods for the separation of mixtures. This important section could be profitably amplified at the expense of omitting the first appendix which lists a group of reagents already mentioned in the text. The book concludes with a second appendix consisting of a comprehensive set of 27 tables of melting points and boiling points of over 800 compounds and their respective derivatives.

Despite its small size the book contains a wealth of information and can be recommended without reserve. R.G.B.

### Chemistry In Photography

PHOTOGRAPHIC CHEMICALS AND CHEMISTRY. By J. Southworth and T. L. J. Bentley. 3rd edition. Sir Isaac Pitman and Sons Ltd., London, 1956. Pp. viii+128. 10s. 6d.

Photography is perhaps one of the best examples of chemistry applied daily without, in the majority of cases, the users understanding much of the fundamental chemical processes. Many of such photographers are, however, willing to fill this gap in their knowledge but are often unwilling or unable to undertake the necessary task of studying chemistry separately from photography.

In meeting the need of students of photography in the position just described, this little text-book will be most valuable, setting out as it does to present aspects of photography to readers little acquainted with chemistry.

Nine years have elapsed since the 2nd edition and in the present edition a considerable number of small changes have been made to bring the text up to date. The book is divided into four main parts.

The first part gives an introduction to chemistry and discusses important topics such as chemical elements, combination, combining weights, atomic theory, important reactions, and ions, pH values, and hydrolysis. Although this section does treat the subject in an elementary fashion, it gives an accurate, concise account of the important theories and facts.

The second part deals with the

chemistry of photographic negative processes, discussing plates and films, the latent image, development, fixing, hardening, washing, drying, and after-treatment.

In the third part the chemistry of the photographic positive processes is presented. Included are treatments of silver printing-out papers, silver development papers and various printing processes.

The final part of the book gives an alphabetical list, with particulars, of all the chemicals a photographer is likely to use and very useful tables of solubilities of the principal substances used in photography.

On page 96,  $\text{Pb}(\text{CH}_3\text{COO})_2 \cdot 3\text{H}_2\text{O}$  and  $\text{Pb}(\text{NO}_3)_2$  are wrongly listed as plumbic acetate and nitrate. These should be plumbous acetate and nitrate.

The authors have achieved their object in this book, and with a little publicity it should sell well and be a very useful asset to amateur and professional photographers. R. J. MAGEE.

### Growing Importance of Polarographic Analysis

DIE POLAROGRAPHIE IN DER MEDIZIN, BIOCHEMIE UND PHARMAZIE. By M. Brezina and P. Zuman. Akademische Verlagsgesellschaft Geest und Portig, Leipzig. Pp. 800. DM 48.

In recent years, the application of physical techniques has increased both the scope and accuracy of analytical chemistry, especially in the field of organic analysis. Polarography holds an important place among physical techniques of analysis, and its versatility, speed and high sensitivity have proved of special value in solving some of the analytical problems posed by biochemistry. Indeed, many trace constituents of biological materials defy analysis by other methods.

This book of biological polarography is largely based on a volume published in Czechoslovakia, the home of polarography, in 1952. However, the original text has been revised extensively before translation, and the fact that the number of literature references has grown from 1,000 to 2,000 is a symptom of the increasing importance of polarographic analysis.

The authors provide a detailed critical survey of the application of polarography to the determination of a wide variety of substances of interest in medicine, biochemistry and pharmacy. Inorganic anions and cations are dealt with in 100 pages, which are followed by a valuable account of the estimation of oxygen. About 640 pages are devoted to organic substances including vitamins, hormones, alkaloids, and a wide range of less complex compounds. A separate chapter deals with analytical techniques depending on the suppression of polarographic maxima by surface-active substances. The book also includes a list of buffer solutions, extensive tables of half-wave potentials (70 pages) and excellent indexes.

The volume is designed as a laboratory manual, experimental details being given for most of the methods discussed. This is particularly valuable in view of the inaccessibility of many of the original papers on polarography. The authors' timely survey of the scattered literature should therefore do much to encourage a wider application of this powerful technique to the analysis of biological materials. J.C.P.S.

### Change of Address

Laporte Midlands subsidiary, A. W. Brook Ltd., have moved from Dun's Lane to 153 Parker Drive, Leicester, where modern offices and extensive warehouse accommodation have just been completed. This change will facilitate the further extension of Laporte interests in the Midlands. Telephone number is Leicester 63861.

### Anti-stripping Agent Calculator

Chemical Division of Armour and Co. Ltd. announce the production of a Duomeen T calculator which indicates, on a rotatable disc, the percentage of Duomeen T anti-stripping agent required for surface dressing. It is available free of charge from the company at Lindsey Street, Smithfield, London EC1.

**Technical** 6d.  
**BOOKGUIDE** Monthly  
**DESCRIBES THE MONTH'S NEW TECHNICAL BOOKS**

No. 1 (April) out April 1, lists 250 titles (inc. Chemistry & Physics) 6d. at Newsagents By post 8d (6 months 4/-) 21 Lower Belgrave St., London, S.W.1

● **MR. WILLIAM GERALD HARTLAND**, of Widnes, who recently retired from the service of Joseph Crosfield and Sons Ltd., Warrington, belongs to a family which has given 800 years of its life's work to the soap industry. The Hartland chapel, Widnes, is named after the first William Hartland, who started to work for Gossages, Widnes, in the early 1850s. Gossages works were subsequently taken over by Crosfields.

● **MR. H. RUSH SPEDDEN** has been appointed director of research of Union Carbide Ore Co., a division of Union Carbide and Carbon Corporation, New York. He will be responsible for Union Carbide Ore Co.'s operations in the corporation's nuclear research centre in Sterling Forest, New York.

● Among passengers who sailed in the *Queen Mary* from Southampton for New York on 20 March were **MR. MALCOLM McALLISTER**, president, Berkshire Chemical Co., New York; and **MR. A. M. BAER**, vice-chairman, Consolidated Zinc Corporation Ltd., London.

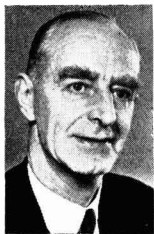

**Mr. George Brearley, who, as reported last week, will leave Cremer and Brearley on 31 March on his appointment to the Association of British Chemical Manufacturers. He will succeed Mr. Davidson Pratt as director and secretary on 1 June**

● **MR. JOHN M. BUTLER**, appointed managing director of Lewis Berger (Great Britain) Ltd., paint manufacturers, from 1 April, is joining the Berger group after 21 years' service with the Shell group. Mr. Butler was general marketing manager of the Shell Chemical Co. Ltd. since its formation.

● **DR. I. H. RILEY** is co-author of a paper 'Silicone rubber—its growth and recent developments' presented at the international synthetic rubber symposium, held from 26 to 28 March (see page 559). Dr. Riley is in charge of the rubber laboratory of the technical service department of Midland Silicones Ltd., which carries out application development work and provides technical information.

● **MR. W. GORDON CAREY, F.R.I.C.**, chemist and bacteriologist with the Sunderland and South Shields Water Co., has been elected president of the Society for Water Treatment and Examination, an international organisation. He is public analyst for Sunderland, Gateshead and Newcastle-upon-Tyne.

● Leaving London Airport on 1 April on a visit to clients in Australia and the Far East is **MR. EDWIN G. FISHER** of 4 Palace Court, London W2, an independent con-

# People in the NEWS

sulting engineer to the plastics industry. In the last four years he has covered a distance of 130,000 miles, over five times the earth's circumference, studying at first hand the latest developments in the plastics industries of the various countries he visits.

● At the annual meeting of the Huddersfield section of the Society of Dyers and Colourists **MR. H. BOOTHROYD** was elected chairman and **MR. G. H. BINNS**, vice-chairman. **MR. HORACE TURNER** was re-elected for his 36th term of office as honorary secretary.

● **MR. E. W. CHIVERS** has been appointed deputy director of the Ministry of Supply's Armament Research and Development Establishment, with effect from 1 April.

● Council of the British Plastics Federation for the session 1957-58 have elected **MR. H. V. POTTER**, chairman of Bakelite Ltd., who was chairman of the Federation from 1937-1938, president in succession to **MR. W. CHARLES WAGHORNE**. **MR. C. C. LAST**, Bakelite Ltd., and **MR. N. B. PUNFIELD**, Punfield and Barstow Ltd., were re-elected chairman and vice-chairman respectively.

● **MR. N. YOUATT**, managing director of Rhodes, Byrdon and Youatt Ltd., manufacturers of centrifugal pumps for chemical and process duties, starts a world sales tour in April. He will visit Malaya, Australia, New Zealand, South America.

*H. L. Howard (right) receiving the Hinchley Medal from G. T. Gurr, president, British Association of Chemists. The Hinchley Medal Address, presented last week by Mr. Howard under the title 'Chemists and the Community' was reported in CHEMICAL AGE, 23 March, page 509.*

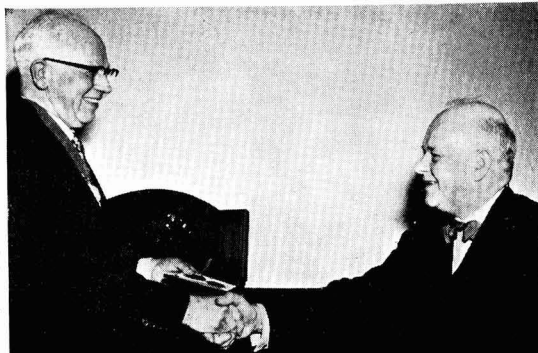

the US and Canada. **MR. W. LATTA**, sales director, has recently completed a three months sales promotion tour of South Africa and the Rhodesias.

● **MR. N. A. NICOLAI**, head of the Russian plastics industry, is to lead a mission from the USSR plastics industry that is to visit this country, probably in April, with the encouragement of the Board of Trade and the British Embassy in Moscow. This is a return visit, following that made by three representatives of the British Plastics Federation to Russia last October.

● **MR. CHARLES W. PROUDFIT** has been appointed director of sales of the newly created resin products department of Celanese Corporation of America's plastics division. He will supervise sales of Celanese polyester resins and polyvinyl acetate emulsions.

● The committee of the microbiology group, Society of Chemical Industry, has elected the following officers for the session 1957-8: Chairman, **MR. D. H. F. CLAYSON**; vice-chairman, **PROFESSOR E. L. CROSSLEY**; honorary treasurer, **DR. F. H. BANFIELD**; honorary secretary, **MR. W. W. REID**; honorary recorder, **MR. R. ELSWORTH**.

● **MR. ERNEST MARKHAM**, a director and sales manager of Peter Brotherhood Ltd., Peterborough, has been elected the next president of the Whitworth Society. All members of the society must hold a Whitworth Award.

● **MR. D. F. HARRISON** has taken over the duties of honorary secretary of the Hull Chemical and Engineering Society from **MR. R. J. ANTROBUS** who is emigrating to Australia.

## Obituary

**MR. WILLIAM B. WALKER**, chief chemist and in charge of quality control and inspection at J. S. Fry and Sons Ltd., has died at the age of 58. He joined the company in 1923 and became an active member of the food group, Society of Chemical Industries and the local section, Royal Institute of Chemistry.

## Commercial News

# Albright & Wilson to Transfer Production to Subsidiary

A SECOND interim of 13 per cent on ordinary, payable on 8 May, is declared by Albright and Wilson Ltd. This is a final payment, making 18 per cent. Comparison of profit and loss account with 1955 is difficult because of the acquisition of Marchon Products late in that year.

As already announced, A and W holding shares in its US subsidiary, Oldbury Electro-Chemical Co., were exchanged in November 1956 for shares in Hooker Electro-Chemical Co. Profits of Oldbury Electro-Chemical Co., have been included in 1956 accounts.

Trading profit for 1956 was £4,416,000 (£3,200,000). Profit, before taxation, was £2,594,000 (£1,801,000)—after taxation £1,231,000 (£781,000). Profit to stockholders of Albright and Wilson Ltd., £1,203,000 (£859,000). In order to confine the company's efforts to group affairs manufacturing assets and activities are to be transferred to a wholly-owned subsidiary.

### Monsanto Chemicals

Resolutions were passed at the extraordinary meeting of Monsanto Chemicals Ltd., on 15 March reconverting the 5s ordinary stock into 5s shares and increasing the capital to £10 million by the creation of 14.8 million 5s ordinary shares. 5.4 million ordinary shares of 5s each are being made available at 7s 6d each to ordinary stockholders in the proportion of one for every two held on 1 March.

### C. E. Ramsden and Co.

Net profit for 1956 of C. E. Ramsden and Co. Ltd., manufacturers of colours and chemicals, was £34,447 (£28,747). Dividend of 25 per cent (20 per cent is declared).

### Revertex

Mr. D. H. Scott, chairman of Revertex Ltd., in his annual report says that the new Alcotex (polyvinyl alcohol) plant at Harrow is now practically complete and that running-in processes are under way.

### Monsanto (Australia)

Net profit of A£146,002 for 1956 is announced by Monsanto Chemicals Australia. This compares with a net profit of A£145,188 for the year to 30 June 1955 and A£100,253 for the six months ended 31 December 1955.

### Leek Chemicals

Net profit of Sir Thomas and Arthur Wardle Ltd., for 1956, was £25,303 (£85,518). Dividend of 8 per cent (10 per cent) is declared on ordinary. During the past year, Leek Chemicals, a subsidiary was registered and took over the work of the existing chemical department from 1

July. When alterations to a factory purchased near the works by the River Churnett are complete, the whole of the chemical section will be transferred there.

During the half year in which it operated, the chemical company incurred a loss of just over £5,000, but Mr. A. H. Atkins, chairman, says the chemical business has always been a seasonal one, the bulk of the turnover being done in the first six months of the year.

### NEW COMPANIES

**BADGERMAN LTD.** Capital £1,000. To engineer, design, construct and operate apparatus, buildings, and plants for the distillation and production of petroleum products, chemicals and related products etc. Directors: A. J. Brogini, R. A. King, E. E. Maltby. Registered Office: Stafford House, Norfolk Street, London WC2.

**BOX FEED MILL LTD.** Capital £3,000. Manufacturers and importers of and dealers in fertilisers, etc. Directors: M. C. Schaul, and M. R. D. Burch. Reg. office: 15 Lots Road, London SW10.

**MANDEN LTD.** Capital £100 in £1 shares. Manufacturers of and dealers in engineering products, plant, machinery; chemicals, paints, plastics and plastics materials etc. Directors: Peter M. Stanley and John A. Smith. Secretary: J. A. Smith. Reg. office: 356 Cowpen Road, Blyth, Northumberland.

**PROPRIETARY CHEMICALS LTD.** Capital £100 in £ shares. Manufacturers of and wholesalers and retail dealers in deodorants, disinfectants, chemicals, chemical products etc. Secretary: R. E. Edwards. Reg. office: 51 Fairclough Lane, Liverpool 17.

## Market Reports

### STRONG SEASONAL CALL FOR FERTILISERS

**LONDON** Buying interest on the industrial chemicals market has been sustained with good quantities moving against contracts. Export inquiry is also on a satisfactory scale. Hydrogen peroxide, formaldehyde, borax and boric acid are in good request while the seasonal demand for fertilisers is strong with pressure for deliveries. There have been no important price changes on the week and the undertone is firm.

There is a good outlet for most of the coal-tar products.

**MANCHESTER** Trading conditions on the Manchester chemical market during the past week have been reasonably steady so far as contract deliveries are concerned. Most leading industrial consumers in the Lancashire area have been

**MILTON - DEOSAN (SCOTLAND) LTD.** Capital £5,000. Manufacturers of antiseptics, detergents and disinfectants.

### MORTGAGES & CHARGES

**ANTI-CORROSIVE FINISHES LTD.**, Stockport. 15 February, charge, to Vernon Building Society securing £4,500 and further advances; charged on land with works etc., thereon at Lingard Lane and Ashton Road, Bredbury.

**RUBEROID CO. LTD.**, London WC. 13 February, £1,000,000 debenture stock together with a premium of one per cent payable in certain events secured by a Trust Deed dated 11 February 1957; charged on properties at Brimsdown and a general charge.

### SATISFACTION

**GRIMSHAW BROTHERS & CO. LTD.**, Manchester, chemical manufacturers etc. Satisfaction 26 February of mortgage registered April 1951.

### Abbott Laboratories to Expand British Plant

A THREE-FOLD increase in the capacity of their British plant at Jarrow, Co. Durham, and a new plant in Argentina, are among the 1957 plans of Abbott Laboratories, Chicago, producers of pharmaceuticals and fine chemicals. Capacity of the Jarrow plant was expanded by 25 per cent in 1955; by the middle of this year new facilities will triple its output.

The Argentine plant, already under way, is expected to be in full production by April 1958 and will produce a wide range of pharmaceuticals and bulk chemicals.

### Glasgow Works Extended

Plant of Associated Metal Works (Glasgow) Ltd., has been extended to meet a growing demand for fabricated steel work for the chemical, petroleum and other industries. Space has been extended by 25 per cent and new finishing and assembly shops incorporated, enabling the production of a fuller range of sizes and bulks. Output in stainless steel, monel, copper and aluminium will be expanded.

specifying regularly for deliveries, and a fair number of home and export inquiries have been circulating during the past few days. Prices generally continue to a firm basis. An active movement of supplies has been reported in most sections of the fertiliser trade, and a ready outlet is being found for the principal light and heavy tar products.

**GLASGOW** Conditions generally in the Scottish market were rather quieter and demands were mostly for nominal current requirements. In regard to fertilisers, rather more activity can be reported, and has shown itself both in immediate and forward bookings. Prices have been fairly steady, although there have been some slight increases.



# NEW PATENTS

By permission of the Controller, HM Stationery Office, the following extracts are reproduced from the 'Official Journal (Patents)', which is available from the Patent Office (Sale Branch), 25 Southampton Buildings, Chancery Lane, London, WC2, price 2s 6d including postage; annual subscription £6 6s.

Specifications filed in connection with the acceptances in the following list will be open to public inspection. Opposition to the grant of a patent on any of the applications listed may be lodged by filing patents form 12 at any time within the prescribed period. Dates on which these applications will be open to inspection are given in 'Official Journal (Patents)'.

## ACCEPTED SPECIFICATIONS

Arrangement for heating powdered cement raw materials or other fine granular materials. Klockner-Humboldt-Deutz AG. **773 841**  
 Washing and cleansing emulsions. Regen, W. **773 625**  
 Pyridyl-bromobenzyl-dialkyl diamines. Veritas Drug Co. Ltd. **773 627**  
 Pregnane compounds. American Cyanamid Co. **773 926**  
 9 - Aminoalkyl-9-xanthencarboxamides and derivatives thereof. Searle, G. D., and Co. **773 756**  
 Steroids. Upjohn Co. [Addition to 724 094.] **773 628, 773 928, 774 064**  
 14-Bromocodeinone. Merck and Co. Inc. **773 630**  
 Treating zinciferous surfaces. American Chemical Paint Co. **773 757**  
 Stabilisation of chlorinated hydrocarbons. Diamond Alkali Co. **773 632**  
 Elastomer and polyvinyl resin blends. General Electric Co. **773 938**  
 Aqueous penicillin suspension comprising inositol phosphoric acids and their salts. Bristol Laboratories Inc. **773 637**  
 Production of alkali metals and magnesium. Pechiney Compagnie de Produits Chimiques et Electrometallurgiques. **773 940**  
 Disodium glutamate. International Minerals and Chemical Corp. **773 647**  
 Resolution of dl-pyrrolidonecarboxylic acid. International Minerals and Chemical Corp. **773 648**  
 Preventing an increase in salts concentration in working medium of steam power plant. Sulzer Freres SA. **773 649**  
 Resolution of dl- $\alpha$ -amino dicarboxylic acids. International Minerals and Chemical Corp. **773 653**  
 Liquid composition for cleaning windows. British Petroleum Co. Ltd., Pethrick, S. R., and Godsav, L. A. **773 857**  
 Ethoxyline resin-hexachloroendomethylene-tetrahydrophthalic anhydride compositions having improved pot life. General Electric Co. **773 655**  
 Resolving a racemic modification of a non-basic alpha-amino carboxylic acid. International Minerals and Chemical Corp. **773 660**  
 Resolving dl-glutamic acid. International Minerals and Chemical Corp. **773 661**

Water-soluble sulphonation products of polymeric aryl-vinyltoluenes. Dow Chemical Co. **773 956**  
 Isonicotinylhydrazide derivative. Soc. des Usines Chimiques Rhone-Poulenc. **773 862**  
 Vitamin A<sub>1</sub> and esters thereof. Hoffmann-La Roche, F., and Co. AG. **773 863**  
 15, 15'-Cis betacarotene. Hoffman-La Roche, F., and C. AG. **773 864**  
 Linear high polymers with thiourea as a constituent. Toyo Katsuo Industries Inc. [Divided out of 773 964.] **773 965**  
 Spectrometers. Touvet, G. **774 473** and **774 476**  
 Extraction of uranium from ore. United Kingdom Atomic Energy Authority. **774 371**  
 Process of pigment printing and pigment padding textiles. Farbenfabriken Bayer, AG. **774 101**  
 Halogenated organic compounds. Haszeldine, R. N. **774 103**  
 Extraction of high-grade products from raw material containing pit coal or brown coal. Bergwerksverband Zur Verwertung Von Schutzrechten der Kohletechnik. Ges. [Addition to 744 131.] **774 273**  
 Antipruritic and analgesic composition. Rheinpreussen AG. Fuer Bergbau und Chemie. **774 107**  
 Manufacture of compounds CO<sub>2</sub>NCIS. CO<sub>2</sub>NCIS<sub>2</sub> and C<sub>2</sub>O<sub>2</sub>N<sub>2</sub>Cl<sub>2</sub>S. Farbwerke Hoechst, AG. **774 276**  
 Catalytic reforming of hydrocarbons. Socony Mobil Oil Co., Inc. **774 515**  
 Organic compounds of aluminium. Ziegler, K. **774 516**  
 Pigment dispersions in water. Auer, L. **774 079**  
 Oil-in-water emulsion type textile printing pastes. Auer, L. **774 080**  
 Interference polarising device for study of phase objects. Centre National de La Recherche Scientifique. **774 277**  
 Preparation of derivatives of sarmentogenin. Naamlooze Vennootschap Organon. **774 081**  
 Process for finishing dyes or prints of vat dyestuffs. Ciba Ltd. **774 518**  
 Separating components of fusible materials. Western Electric Co., Inc. **774 269**  
 Therapeutically useful solutions. Farbenfabriken Bayer, AG. **774 110**  
 Amate-dicarboxylate-thickened grease. California Research Corp. **774 084**  
 Polyamide grease composition. California Research Corp. **774 085**  
 Polyamide-polyamate-thickened greases. California Research Corp. **774 086**  
 Phenol - formaldehyde derivatives. National Research Development Corp. **774 282**  
 Combined purification and methanisation of gas mixtures containing oxides of carbon and hydrogen. Ruhrchemie, AG. **774 283**  
 Dialkyl esters of sulphuric acid. Minister of Supply. **774 384**  
 Control of gaseous media in manufacturing processes. Tootal Broadhurst Lee Co. Ltd. **774 284**  
 Pregnane derivatives. Organon Laboratories Ltd. **774 082**  
 Derivatives of etiocholanolic acid. Naamlooze Vennootschap Organon. **774 083**  
 Treatment of catalysts. Rheinpreussen, AG. Fuer Bergbau und Chemie. **774 285**  
 Washing agents or detergents. Busch, G. L. **774 523**

Pyrimidine compounds. Wellcome Foundation Ltd. **774 094** and **774 095**  
 Brazing of molybdenum and molybdenum-tungsten alloy. British Thomson-Houston Co. Ltd. **774 291**  
 Liquid-dispensing apparatus. Findlay, A. J. **774 118**  
 Parasiticial compositions. Esso Research & Engineering Co. **774 392**  
 Complex alkoxy metal salts of organic acids and lubricating and fuel compositions thereof. Socony Mobil Oil Co., Inc. **774 119**  
 Divalent heavy metal bicyclopentadienides. California Research Corp. **774 529**  
 Treatment of soapstock. Unilever Ltd. **774 532**  
 Therapeutically valuable hydantoin derivatives. Cassella Farbwerke Mainkur, AG. **774 394**  
 Liquid phase dehydrohalogenation of organic halogen-containing compounds. Dominion Tar & Chemical Co. Ltd. **774 125**  
 Coloration of cellulose acetate textile yarns and fabrics. Marchington, T. E. & Co. Ltd. **774 537**  
 Heat-producing mixtures. Foundry Services Ltd. [Addition to 627 678.] **774 490** and **774 491**  
 Separation of solids from mixtures of solids and gases and apparatus therefor. Esso Research & Engineering Co. **774 543**  
 Endo-cyclic polyols. H. Newby (Chemische Werke Huls, AG.) **774 408**  
 Hydraulic fluids. Monsanto Chemicals Ltd. **774 544**  
 Fat mixtures and emulsions thereof. Aktiebolaget Kabi. **774 201**  
 Production of molecularly modified lard. Armour & Co. **774 547**  
 Dispersions in starch. Corn Products Refining Co. **774 549**  
 Manufacture of titanium. Imperial Chemical Industries Ltd. **774 133**  
 Apparatus for emptying containers of iron oxide or the like. Newton, Chambers & Co. Ltd. **774 311**  
 Hydrocarbon cracking process. Texaco Development Corp. **774 135**  
 Method and apparatus for detecting leaks in pipe lines. United Kingdom Atomic Energy Authority. **774 136**  
 Hydroxy-substituted unsaturated esters. Naamlooze Vennootschap de Bataafsche Petroleum Maatschappij. **774 420**  
 Flotation process for separating sodium chloride from kainite. Montecatini Soc. Generale per L'Industria Mineraria e Chimica. **774 313**  
 Separating low boiling tar acids from a mixture with low boiling neutral oils. Pittsburgh Consolidation Coal Co. **774 316**  
 Air-lift type mixer-settler apparatus. United Kingdom Atomic Energy Authority. **774 554**  
 Manufacture of extrusion products of indefinite length. Schloemann, AG. **774 431**  
 Detergent compositions. Monsanto Chemical Co. **774 556**  
 Metallised effects on textiles. Heberlein & Co., AG. **774 223**  
 Fodder from medullary substances of sugar beet, sugar cane and other sugar-containing plants in the manufacture of sugar. Steckel, W. H. **774 318**  
 Absorption of silicon tetrafluoride. International Minerals & Chemical Corp. **774 319**  
 Dyeing or printing polyacrylonitrile fibres. Badische Anilin- & Soda-Fabrik, AG. **774 320**  
 Hydroxyalkane-sulphonic acids from their salts. Boehme Fettechemie Ges. **774 563**  
 Metalliferous polyazo dyestuffs. Sandoz Ltd. **774 150**

# BRITISH CHEMICAL PRICES

## General Chemicals

**Acetic Acid.** D/d in ret. barrels (tech. acid barrels free); in glass carboys, £8; demijohns, £12 extra. 80% tech., 10 tons, £97; 80% pure, 10 tons, £103; commercial glacial, 10 tons, £106.

**Acetic Anhydride.** Ton lots d/d, £136.

**Alum.** Ground, f.o.r., about £25.

MANCHESTER: Ground, £25.

**Aluminium Sulphate.** Ex-works, d/d, £15 10s.

MANCHESTER: £15 15s to £18 10s.

**Ammonia, Anhydrous.** Per lb., 1s 9d to 2s 3d.

**Ammonium Chloride.** Per ton lot, in non-ret. pack, £29 2s 6d.

**Ammonium Nitrate.** D/d, in 4-ton lots, £31.

**Ammonium Persulphate.** MANCHESTER: per cwt., in 1-cwt. lots, d/d, £6 2s 6d; per ton, in min. 1-ton lots, d/d, £112 10s.

**Ammonium Phosphate.** Mono- and di-, ton lots, d/d, £106 and £97 10s.

**Antimony Sulphide.** Per lb., d/d UK in min. 1-ton lots: crimson, 4s 5d to 4s 10½d; golden, 2s 8½d to 4s 1¼d.

**Arsenic.** Ex-store, £45 to £50.

**Barium Carbonate.** Precip., d/d, 4-ton lots, bag packing, £41.

**Barium Chloride.** 2-ton lots, £49.

**Barium Sulphate (Dry Blanc Fixe).** Precip. 2-ton lots, d/d, £35.

**Bleaching Powder.** Ret. casks, c.p. station, in 4-ton lots, £28 12s 6d.

**Borax.** Ton lots, in hessian sacks, c.p. Tech., anhydrous, £62 10s; gran., £45; crystal, £47 10s; powder, £48 10s; extra fine powder, £49 10s; BP, gran., £51; crystal, £56 10s; powder, £57 10s; extra fine powder, £58 10s.

**Boric Acid.** Ton lots, in hessian sacks, c.p. Tech., gran., £74 10s; crystal, £82 10s; powder, £80; extra fine powder, £82; BP gran., £87 10s; crystal, £94 10s; powder, £92; extra fine powder, £94.

**Calcium Chloride.** Ton lots, in non-ret. pack: solid and flake, £16.

**Chlorine, Liquid.** In ret. 16-17-cwt. drums d/d in 3-drum lots, £38 5s.

**Chromic Acid.** Less 2½% d/d UK, in 1-ton lots, per lb., 2s 0½d.

**Chromium Sulphate, Basic.** Crystals, d/d, per lb., 8½d; per ton, £75 16s 8d.

**Citric Acid.** 1-cwt. lots, per cwt., £10 15s.

**Cobalt Oxide.** Black, per lb., d/d, bulk quantities, 13s 2d.

**Copper Carbonate.** Per lb., 3s 8d.

**Copper Sulphate.** F.o.b., less 2% in 2-cwt. bags, £89 10s.

**Cream of Tartar.** 100%, per cwt., about £11 12s.

**Formaldehyde.** In casks, d/d, £37 5s.

**Formic Acid.** 85%, in 4-ton lots, c.p., £86 10s.

**Glycerine.** Chem. pure, double distilled 1.260 s.g., per cwt., in 5-cwt. drums for annual purchases of over 5-ton lots and under 25 tons, £10 1s 6d. Refined pale straw industrial, 5s per cwt. less than chem. pure.

**Hydrochloric Acid.** Spot, per carboy, d/d (according to purity, strength and locality), about 12s.

**Hydrofluoric Acid.** 59/60%, per lb., about 2s 6d per lb.

**Hydrogen Peroxide.** Carboys extra and ret. 27.5% wt., £128 10s; 35% wt., d/d, £158.

**Iodine.** Resublimed BP, under 1 cwt., per lb., 14s 2d; for 1-cwt. lots, per lb., 13s 5d.

**Iodoform.** Under 1 cwt., per lb., £1 2s 3d; for 1-cwt. lots, per lb., £1 2s 6d.

These prices are checked with the manufacturers, but in many cases there are variations according to quality, quantity, place of delivery, etc.

Abbreviations: d/d, delivered; c.p., carriage paid; ret, returnable; non-ret. pack, non-returnable packaging; tech, technical; comm, commercial; gran, granular.

### All prices per ton unless otherwise stated

**Lactic Acid.** Pale tech., 44% by wt., per lb., 14d; dark tech., 44% by wt., ex-works, per lb., 9d; chem. quality, 44% by wt., ex-works, per lb., 12½d; 1-ton lots, usual container terms.

**Lead Acetate.** White, about £154.

**Lead Nitrate.** 1-ton lots, about £135.

**Lead, Red.** Basis prices: Genuine dry red, £141; orange lead, £153 15s. Ground in oil: red, £159; orange, £173.

**Lead, White.** Basis prices: Dry English in 5-cwt. casks, £146 5s. Ground in oil: English, 1-cwt. lots, per cwt., 194s.

**Lime Acetate.** Brown, ton lots, d/d, £40; grey, 80-82%, ton lots, d/d, £45.

**Litharge.** In 5-ton lots, £143.

**Magnesite.** Calcined, in bags, ex-works, about £21.

**Magnesium Carbonate.** Light, comm., d/d, 2-ton lots, £84 10s under 2 tons, £97.

**Magnesium Chloride.** Solid (ex-wharf), £16 10s.

**Magnesium Oxide.** Light, comm., d/d, under 1-ton lots, £245.

**Magnesium Sulphate.** Crystals, £16.

**Mercuric Chloride.** Tech. powder, per lb., for 5-cwt. lots, in 28-lb. parcels, £1 3s; smaller quantities dearer.

**Mercury Sulphide, Red.** 5-cwt. lots in 28-lb. parcels, per lb., £1 9s 3d.

**Nickel Sulphate.**—D/d, buyers UK, nominal, £170.

**Nitric Acid.** 80° Tw., £35.

**Oxalic Acid.** Home manufacture, min. 4-ton lots, in 5-cwt. casks, c.p., about £131.

**Phosphoric Acid.** Tech. (s.g. 1.700) ton lots, c.p., £100; BP (s.g. 1.750), ton lots, c.p., per lb., 1s 4d.

**Potash, Caustic.** Solid, 1-ton lots, £93 10s; liquid, £34 15s.

**Potassium Carbonate.** Calcined, 96/98%, 1-ton lots, ex-store, about £74 10s.

**Potassium Chloride.** Industrial, 96%, 1-ton lots, about £24.

**Potassium Dichromate.** Crystals and gran., per lb., in 5-cwt. to 1-ton lots, d/d UK, 1s 1½d.

**Potassium Iodide.** BP, under 1-cwt., per lb., 10s 3d; per lb. for 1-cwt. lots, 9s 9d.

**Potassium Nitrate.** 4-ton lots, in non-ret. pack, c.p., £63 10s.

**Potassium Permanganate.** BP, 1-cwt. lots, per lb., 1s 10½d; 3-cwt. lots, per lb., 1s 10d; 5-cwt. lots, per lb., 1s 9½d; 1-ton lots, per lb., 1s 9½d; 5-ton lots, per lb., 1s 8½d. Tech., 5-cwt. in 1-cwt. drums, per cwt., £9 8s 6d; 1-cwt. lots, £9 17s 6d.

**Salammoniac.** Ton lot, in non-ret. pack, £45 10s.

**Salicylic Acid.** MANCHESTER: Tech., d/d, per lb., 2s 8½d.

**Soda Ash.** 58% ex-depot or d/d, London station, 1-ton lots, about £16 8s.

**Soda, Caustic.** Solid 76/77% spot, d/d 4-ton lots, £32 6s 6d.

**Sodium Acetate.** Comm. crystals, d/d, £91.

**Sodium Bicarbonate.** Ton lot, in non-ret. pack, £17.

**Sodium Bisulphite.** Powder, 60/62%, d/d, 2-ton lots for home trade, £42 15s.

**Sodium Carbonate Monohydrate.** Ton lot, in non-ret. pack, c.p., £57.

**Sodium Chlorate.** 1-cwt. drums, c.p. station, in 4-ton lots, about £85.

**Sodium Cyanide.** 96/98%, ton lot in 1-cwt. drums, £113 5s.

**Sodium Dichromate.** Crystals, cake and powder, per lb., 11½d. Net d/d UK, anhydrous, per lb., 1s 1d. Net. del. d/d UK, 5-cwt. to 1-ton lots.

**Sodium Fluoride.** D/d, 1-ton lots & over, per cwt., £5; 1-cwt. lots, per cwt., £5 10s.

**Sodium Hyposulphite.** Pea crystals, £35 15s; comm., 1-ton lots, c.p., £32 10s.

**Sodium Iodide.** BP, under 1 cwt., per lb., 14s; 1-cwt. lots, per lb., 13s 2d.

**Sodium Metaphosphate (Calgon).** Flaked, paper sacks, £133.

**Sodium Metasilicate.** D/d UK in ton lots, loaned bags, £25.

**Sodium Nitrate.** Chilean refined gran. over 98%, 6-ton lots, d/d station, £29 10s.

**Sodium Nitrite.** 4-ton lots, £32.

**Sodium Percarbonate.** 12½% available oxygen, per cwt., in 1-cwt. kegs, £8 6s 9d.

**Sodium Phosphate.** D/d, ton lots: disodium, crystalline, £40 10s, anhydrous, £88; tri-sodium, crystalline, £39 10s, anhydrous, £86.

**Sodium Silicate.** 75-84° Tw. Lancs and Ches., 4-ton lots, d/d station in loaned drums, £10 15s; Dorset, Somerset & Devon, per ton extra, £3 17s 6d; Scotland & S. Wales, extra, £3. Elsewhere in England, not Cornwall, extra, £1 12s 6d.

**Sodium Sulphate (Desiccated Glauber's Salts).** D/d in bags, £18.

**Sodium Sulphate (Glauber's Salt).** D/d, £9 5s to £10 5s.

**Sodium Sulphate (Salt Cake).** Unground, d/d station in bulk, £6.

MANCHESTER: d/d station, £7 10s.

**Sodium Sulphide.** Solid, 60/62%, spot, d/d, in drums in 1-ton lots, £33 2s 6d; broken, d/d, in drums in 1-ton lots, £34 2s 6d.

**Sodium Sulphite.** Anhydrous, £66 5s; comm., d/d station in bags, £25 5s-£27.

**Sulphur.** 4 tons or more, ground, according to fineness, £20-£22.

**Sulphuric Acid.** Net, naked at works, 168° Tw. according to quality, £10 7s 6d-£12; 140° Tw., arsenic free, £8 12s 6d; 140° Tw., arsenious, £8 4s 6d.

**Tartaric Acid.** Per cwt.: 10 cwt. or more, £14; 1 cwt., £14 5s.

**Titanium Oxide.** Standard grade comm., rutile structure, £182; standard grade comm., anatase structure, £167 (from 1st Feb.).

**Zinc Oxide.** Max. for 2-ton lots, d/d, white seal, £120; green seal, £113; red seal, 2-ton lots, £115.

## Solvents & Plasticisers

**Acetone.** All d/d, small lots, 5-gal. cans: 5-gal., £125; 10-gal., cans incl., £115. 40/45 gal. rets. drums, spot: Under 1 ton, £90; 1 to under 5 tons, £87; 5 to under 10 tons, £86; 10 tons under, £85. Tank wagons, spot: 1 to under 5 tons (min. 400 gal.), £85; 5 to under 10 tons (1,500 gal.), £84; 10 tons & up (2,500 gal.), £83; contract rebate, £2.

**Butyl Acetate BSS.** 10-ton lots, £173.

**n-Butyl Alcohol BSS.** 10 tons, in drums, d/d, £152.

**sec-Butyl Alcohol.** 5-gal. drums, £159; 40-gal. drums: under 1 ton, £124; 1-10 tons, £123; 10 tons & up, £119; 100 tons & up, £120.

**tert-Butyl Alcohol.** 5-gal. drums, £195 10s; 40/45-gal. drums: 1 ton, £175 10s; 1-5 tons, £174 10s; 5-10 tons, £173 10s; 10 tons & up, £172 10s.

**Diacetone Alcohol.** Small lots: 5-gal. drums, £177; 10-gal. drums, £167. 40/45-gal. drums: under 1 ton, £142; 1-9 tons, £141; 10-50 tons, £140; 50-100 tons, £139; 100 tons & up, £138.

**Dibutyl Phthalate.** In drums, 10 tons, d/d, per lb., 2s; 45-gal. drums, d/d, per lb., 2s 1½d.

**Diethyl Phthalate.** In drums, 10 tons, per lb., 1s 1½d; 45-gal. drums, d/d, per lb., 2s 1d.

**Dimethyl Phthalate.** In drums, 10 tons, per lb., d/d, 1s 9½d; 45-gal. drums, d/d, per lb., 1s 10½d.

**Diocetyl Phthalate.** In drums, 10 tons, d/d, per lb., 2s 8d; 45-gal. drums, d/d, per lb., 2s 9½d.

**Ether BSS.** 1-ton lots, drums extra, per lb., 1s 11d.

**Ethyl Acetate.** 10-ton lots, d/d, £145.

**Ethyl Alcohol (PBS 66 o.p.).** Over 300,000 p. gal. 2s 1½d; d/d in tankers, 2,500-10,000 p. gal., per p. gal., 3s 1½d. D/d in 40/45-gal. drums, p.p.g. extra, 1d. Absolute alcohol (75.2 o.p.), p.p.g. extra, 5d.

**Methanol.** Pure synthetic, d/d, £43 15s.

**Methylated Spirit.** Industrial 66° o.p.: 500-gal. & up, d/d in tankers, per gal., 5s 4d; 100-499 gal. in drums, d/d, per gal., 5s 8½d. Pyridinised 64 o.p.: 500 gal. & up, in tankers, d/d, per gal., 5s 6d; 100-499 gal. in drums, d/d, per gal., 5s 10½d.

**Methyl Ethyl Ketone.** 10-ton lots, d/d, £140.

**Methyl isoButyl Ketone.** 10 tons & up, £159. **isoPropyl Acetate.** In drums, 10 tons, d/d, £137; 45-gal. drums, d/d, £143.

**isoPropyl Alcohol.** Small lots: 5-gal. drums, £118; 10-gal. drums, £108; 40-45 gal. drums: less than 1 ton, £83; 1-9 tons, £81; 10-50 tons, £80 10s; 50 tons & up, £80.

#### Rubber Chemicals

**Carbon Disulphide.** According to quality, £61-£67.

**Carbon Black.** Per lb., according to packing, 8d-1s.

**Carbon Tetrachloride.** Ton lots, £81.

**India-Rubber Substitutes.** White, per lb., 1s 8½d to 2s ½d; dark, d/d, per lb., 1s 3d-1s 5½d.

**Lithopone.** 30%, about £55.

**Mineral Black.** £7 10s-£10.

**Sulphur Chloride.** British, about £50.

**Vegetable Lamp Black.** 2-ton lots, £64 8s.

**Vermilion.** Pale or deep, 7-lb. lots, per lb., 15s 6d.

#### Coal-Tar Products

**Benzole.** Per gal., min. 200 gal., d/d in bulk, 90s, 6s; pure, 6s 4d.

**Carbolic Acid.** Crystals, min. price, d/d bulk, per lb., 1s 4d; 40/50-gal. ret. drums extra, per lb., ½d. Crude, 60s, per gal., 8s.

MANCHESTER: Crystals, d/d, per lb., 1s 4d-1s 7d; crude, naked, at works, 8s.

**Creosote.** Home trade, per gal., according to quality, f.o.r. maker's works, 1s-1s 9d. MANCHESTER: Per gal., 1s-1s 8d.

**Cresylic Acid.** Pale 99/100%, per gal., 6s 4d; 99.5/100%, per gal. 6s 6d. D/d UK in bulk: Pale ADF, per imperial gallon f.o.b. UK, from 7s 3d; per US gallon, c.i.f. NY, 95 cents.

**Naphtha.** Solvent, 90/160°, per gal., 6s 1d; heavy, 90/190°, for bulk 1,000-gal. lots, d/d, per gal., 4s 11d. Drums extra; higher prices for smaller lots.

**Naphthalene.** Crude, 4-ton lots, in buyers' bags, nominal, according to m.p.: £20 11s-£33 11s 6d; hot pressed, bulk, ex-works, £40 1s 9d; refined crystals, d/d min. 4-ton lots, £68.

**Pitch.** Medium, soft, home trade, f.o.r. suppliers' works, £9; export trade, f.o.b. suppliers' port, about £10 10s.

**Pyridine.** 90/160, per gal., 20s-£1 2s 6d.

**Toluole.** Pure, per gal., 6s 9d; 90s, d/d, 2,000 gal. in bulk, per gal., 6s. MANCHESTER: Pure, naked, per gal., 6s 7½d.

**Xylole.** According to grade, in 1,000-gal. lots, d/d London area in bulk, per gal., 7s-7s 8d.

#### Intermediates & Dyes (Prices Nominal)

**m-Cresol 98/100%.** D/d, per lb., 4s 9d.

**o-Cresol 30/31°C.** D/d, per lb., 1s.

**p-Cresol 34/35°C.** D/d, per lb., 4s 9d.

**Dichloraniline.** Per lb., 4s 6d.

**Dinitrobenzene.** 88/99°C., per lb., 2s 1d.

**Dinitrotoluene.** Drums extra. SP 15°C., per lb., 2s 1½d; SP 26°C., per lb., 1s 5d; SP 33°C., per lb., 1s 2½d; SP 66/68°C., per lb., 2s 1d.

**p-Nitraniline.**—Per lb., 5s 1d.

**Nitrobenzene.** Spot, 90-gal. drums (drums extra), 1-ton lots d/d, per lb., 10d.

**Nitronaphthalene.**—Per lb., 2s 5½d.

**o-Tolidine.** 8-10-cwt. drums (drums extra), per lb., 1s 11d.

**p-Tolidine.**—In casks, per lb., 6s 1d.

**Dimethylaniline.** Drums extra, c.p., per lb., 3s 5d.

### Chemical Stocks and Shares

## Budget Hopes Help Rally Markets Despite Recent Strike News

INITIALLY the shipyard and engineering strikes upset stock markets, but it was not long before there was a strong rally. Selling was not heavy, and with hopes of an incentive Budget, and some cuts in taxation prevailing in the City, buyers quickly reappeared. It is, of course, usual for markets to show a pre-Budget rally, but opinions are still much divided whether major tax cuts are possible and also whether they might give too strong a stimulus to the inflation danger.

Chemical and kindred shares have closely reflected the rally in markets. Imperial Chemical, for instance, were up to 42s. 9d. earlier this week, compared with 41s a month ago. The view persists that though profits will probably again be higher, the dividend is likely to be unchanged at 10 per cent. Sentiment in the City has apparently been helped by assumptions as to the big benefits the ICI group would derive in the event of Britain joining the proposed common market.

Albright and Wilson's excellent results also helped sentiment in regard to chemical shares. Albright and Wilson's 5s shares, which were 18s. a month ago, moved up 19s 3d. As forecast by the directors, dividend is maintained at 18 per cent on the larger capital and has been earned nearly 2½ times. Trading profits have advanced from £3,200,000 to £4,416,000, helped, of course, by the acquisition of Marchon Products. Borax Holdings 5s shares remained under the influence of the financial results and were 23s 6d or virtually the same as a month ago. There was again a good deal of activity in Hickson and Welch around

32s 6d. Monsanto 5s shares at 19s 3d were 'ex rights' to the new issue.

British Glues and Chemicals strengthened from 10s 3d to 11s and Fisons moved up from 55s 6d to 56s 6d. On the other hand, Reichhold Chemicals 5s shares at 13s 9d moved slightly lower and Hardman and Holden 5s shares were 8s 3d (9s a month ago). Greff Chemical Holdings 5s shares have firmed up to 17s 6d and William Blythe 3s again changed hands actively around 10s.

The 6s 8d units of The Distillers Co. moved up from 22s 3d to 22s 9d helped by the details the company has given of its important chemical and industrial interests. These should of course become a growing contributor to the company's earnings.

Anchor Chemical 5s shares have eased to 11s 6d and Yorkshire Dyeware and Chemical 5s shares to 9s 3d. Lawes Chemical 10s shares have been steady at 17s 9d and Coalite and Chemical 2s shares changed hands around 3s 9d. British Tar Products 2s 6d shares were 6s 9d and British Duffry Chemicals 5s shares 10s. Powell Chormeyn 10s stock moved up to 23s 3d while British Oxygen at 35s 6d were aided by the good impression created by the financial results and the chairman's speech at the annual meeting this week. It is apparent that the company has big scope for further expansion of its business overseas.

British Xylonite eased from 28s 6d a month ago to 27s 9d but British Industrial Plastics 2s shares were 5s 4½d compared with 4s 9d. Firmness was shown in Boots Drug 5s shares at 15s.



“VULCAN” IRON AND STEEL CARBOY HAMPERS  
SAFETY CRATES, PACKED CARBOYS  
BRAND  
HARRIS (LOSTOCK GRALAM) LTD.  
LOSTOCK GRALAM, NORTHWICH, CHESHIRE.

## FOR YOUR DIARY

### MONDAY 1 APRIL

**CS**—Galway: University College, 7.45 p.m. Joint meeting with Institute of Chemistry of Ireland, RIC and SCI. 'Chemical revolution in textile technology' by Professor J. B. Speakman.

**SCI**—London: Wellcome Building, Euston Road NW1, 11 a.m. Two-day symposium on '5-Hydroxytryptamine'.

### TUESDAY 2 APRIL

**I.Chem.E.**—London: Royal Institution, Albemarle Street W1, 5.30 p.m. 'Aqueous homogeneous reactor' by R. Hurst.

**SCI (Chem. Engng. Group)**—London: 14 Belgrave Square SW1, 5.30 p.m. 'Some applications of statistical control to the chemical industry' by A. G. Baker.

**Incorporated Plant Engineers**—London: Royal Society of Arts, John Adam Street, Adelphi, Strand WC2, 7 p.m. 'Applications of plastics in industry' by Dr. C. L. Child.

### WEDNESDAY 3 APRIL

**CS**—Manchester: Chemistry Lecture Theatre, University, 6.30 p.m. Centenary lecture: 'Photodynamically-active natural pigments' by Professor H. Brockmann.

**SCI (Corrosion Group)**—Newport: Technical College, 7 p.m. 'Protection of structural steel against corrosion' by Dr. J. C. Hudson.

**SAC**—London: Meeting room of

Chemical Society, Burlington House, Piccadilly W1, 7 p.m. 'Fluorimetry': 'Spectrometry of fluorescence' by Dr. E. J. Brown, 'Some experiments with spectro- and filter-fluorimeters' by Dr. C. A. Parker, 'Spectrofluorimetry' by Professor R. T. Williams, 'A direct reading fluorimeter' by L. Brealey and R. E. Ross.

**ASLIB**—London: Industrial Welfare Society, 48 Bryanston Square W1, 2 p.m. 'Availability of atomic energy information' by R. M. Fishenden, and 'Needs of librarians in relation to atomic energy information' by Miss J. Binns.

**NW Fuel Luncheon Club**—Manchester: Engineers' Club, Albert Square, 12.15 p.m. 'Impact of the scientific age' by Sir Henry Self.

### THURSDAY 4 APRIL

**SAC**—London: Meeting room of Chemical Society, Burlington House, Piccadilly W1, 7 p.m. 'Experience in the microbiological assay of vitamins and amino-acids by large plate methods' by D. F. Harris and J. S. Simpson, and 'Quantitative analysis of immunologically specific substances in agar gel plates' by J. G. Feinberg.

**Institute of Metals**—London: 17 Belgrave Square SW1, 6 p.m. Annual general meeting followed by 'Recent developments in electron microscopy' by Dr. J. Nutting.

**Society of Instrument Technology**—London: National College of Horology and Instrument Technology, Northampton Polytechnic, St. John Street EC1, 6.30 p.m. Discussion: 'Education' opened by C. J. Charnley and S. W. J. Wallis.

### FRIDAY 5 APRIL

**CS**—Newcastle upon Tyne: Chemistry Building, King's College, 5.30 p.m. Centenary lecture: 'Photodynamically-active natural pigments' by Professor H. Brockmann.

**CS**—Portsmouth: College of Technology, Anglesea Road, 7 p.m. 'Many-centre bonds' by Professor H. C. Longuet-Higgins.

**SCI**—Manchester: University, 6 p.m. Annual general meeting followed, at 6.30 p.m., by 'Automation and education—some views of a chemical engineer on trends in the chemical industry' by Dr. F. P. Stainthorpe.

**Society of Cosmetic Chemists**—London: Royal Society of Arts, John Adam Street, Strand WC2, 7.30 p.m. 'Cationic surface active agents' by P. A. Lincoln.

### University Salaries

The increase in the minimum and maximum salaries of assistant university lecturers, following introduction of the new scales, is £150 and £200 respectively. This was stated by the Chancellor of the Exchequer in the House last week.

### Import Duty Exemption

Exemption of titanium dioxide from import duty is continued for a further three months by the Import Duties (Exemptions (No. 2) Order SI 1957/441).



The crank shaft is the heart of the engine and the lubricating oil is its heart's blood.

Stream-Line filters enable first grade lubricating oil to be kept always perfectly clean and used over and over again, increasing running efficiency and effecting a big saving in overhauls and maintenance.

Over 50,000 users are proving the value of Stream-Line filters in the economical operation of i.c. engines.

## STREAM-LINE FILTERS

*Make oil lubricate longer*

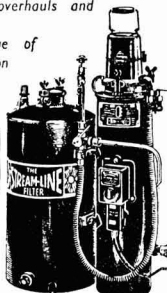

STREAM-LINE FILTERS LTD, INGATE PLACE, LONDON, S W 8. TELEPHONE: MACAULAY 1011

## STOCKHOLDERS OF Power Plant & Machinery

### BOILERS

LANCASHIRE ECONOMIC VERTICAL COCHRAN AND LOCO. TYPE

### MACHINE TOOLS

LATHES, DRILLING, MILLING AND SCREWING MACHINES, GRINDERS, ETC.

### PUMPS

MOTOR, STEAM AND BELT-DRIVEN, FOR BOILER FEED AND OTHER DUTIES

AIR COMPRESSORS AND RECEIVERS ELECTRIC MOTORS AND GENERATORS HYDRAULIC PRESSES AND PUMPS CONTRACTORS' PLANT- WOODWORKING MACHINERY-CRANES AND LIFTING APPLIANCES-STORAGE TANKS

Comprehensive stocks held for Quick Delivery

**CHRIS · HOLDEN · LIMITED**  
BANK TOP WORKS · BLACKBURN · LANCASHIRE  
Telephones : 4181-3      Telegrams : PENETRATE.  
Codes : A.B.C. 5th Edn. BENTLEY'S.

LET US QUOTE YOU FOR THE

## IN SITU SERVICING

OF THE

## FINE BALANCES IN YOUR LABORATORY

## S. GARCIA LTD

DEPT. C.A.10

780 · SEVEN SISTERS ROAD · LONDON · N15  
Tel : STAMFORD HILL 1781      Telegrams : POISE SOUTHTOT LONDON

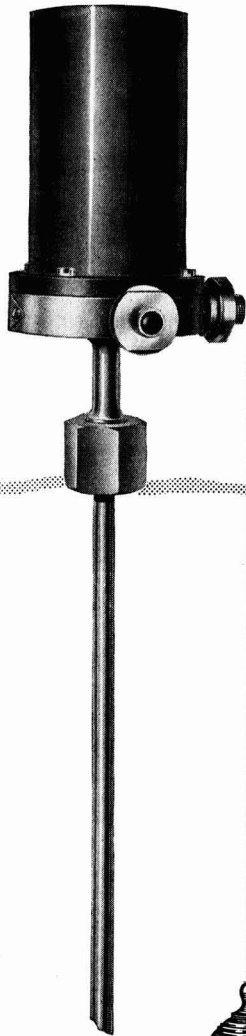

Accurate, reliable  
readings and rapid  
response from this  
**TEMPERATURE  
TRANSMITTER**  
one of the  
**PNEUTECHNIQUE**  
components for industry

*In many industries* where there are temperatures to measure and/or control, this temperature transmitter does a wonderfully efficient job.

One of Negretti & Zambra's Pneutechnique components, it converts temperature into linear output air pressure which is transmitted through small-bore tubing to the receiving instrument. The inherent robustness of the mercury-in-steel method is combined with a particular sensitivity and precision peculiar to all our pneumatic components.

Range extends up to 1200° F. Spans of 30 F° or 15 C° are normally available, also compensated models and models for low temperature applications. The transmitter can be used to actuate an air-operated controller to maintain temperature within specific limits.

Write for illustrated brochure T/39/1.

**NEGRETTI**

**& ZAMBRA**



NEGRETTI & ZAMBRA LTD., REGENT STREET, LONDON  
Telephone: REGent 3406

**accurate**

**particle size analysis**

Vibration alone or hand shaking is not sufficient for accurate particle size analysis of materials. Vibration alone is more inclined to aggregate the particles. The Inclyno Test Sieve Shaker ensures perfect segregation of the various particles' sizes in the shortest possible time having a double movement of gyrating and jolting the test material.

The Inclyno Test Sieve Shaker is an essential unit for all laboratories and is standard equipment in many government laboratories, nationalized industries and industry in general.

Operated by a fractional h.p. motor and supplied complete with automatic time switch covering test periods up to 60 minutes. Models available for all sizes of standard test sieves.

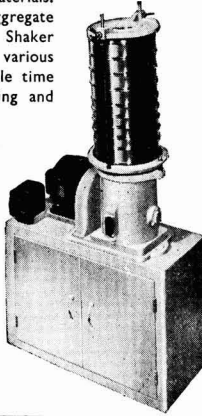

**INCLYNO**

TEST SIEVE SHAKER

Write or telephone  
Crawley 25166 for  
List IN 904

**THE PASCALL ENGINEERING CO. LTD.**  
GATWICK ROAD-CRAWLEY. SUSSEX

**Lithium  
Carbonate  
98/99%**

BRITISH MANUFACTURE

COMPETITIVE PRICES

BULK PRODUCTION

PROMPT DELIVERIES FROM STOCK

**ASSOCIATED LEAD** MANUFACTURERS LIMITED



SPECIAL CHEMICALS DIVISION, CRESCENT HOUSE, NEWCASTLE UPON TYNE, 1



**LABORATORY GLASSWARE**

leads in Quality,  
Accuracy  
and  
Functional Design

Hydrometers  
Thermometers  
Viscometers  
Volumetric Glassware  
E-MIL Vogel  
Small Scale Apparatus

designed by Arthur I. Vogel  
D.Sc. (Lond) D.I.C., F.R.I.C.



**MANY PRICE  
REDUCTIONS**

are contained in the new  
E-MIL price list and  
supplement which together  
with catalogues are now  
available on request



**We shall be glad to  
see you on Stand 414**

at the Instruments  
Electronics & Automation  
Exhibition

**Olympia 7-17 May 1957**



**H. J. ELLIOTT LIMITED**

TREFOREST INDUSTRIAL ESTATE, PONTYPRIDD, GLAMORGAN

# ETHANOLAMINES

# POLYETHYLENE GLYCOLS

used in the manufacture and formulation of a wide range of important products, including

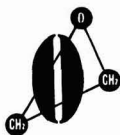

dyes  
morpholine  
non-ionic detergents  
spinning lubricants  
foam stabilizers  
shampoos  
accelerators  
synthetic lubricants  
hydraulic fluids

*The materials can also be used as humectants, plasticisers and mould release agents*

Full information and samples on request to:

# OXIRANE LIMITED

*A wholly-owned subsidiary of Petrochemicals Limited*

SOUTHERN DIVISIONAL SALES OFFICE

76 STRAND, LONDON, W.C.2.

Telephone: COVEnt Garden 3011

NORTHERN DIVISIONAL SALES OFFICE

144/146 DEANS GATE, MANCHESTER 3

Telephone: Blackfriars 4852

170 Piccadilly, London, W.1.

Telephone: MAYfair 6618

Can your problem be expressed in terms of viscosity?  
Do you want a practical tool, suitable for routine and  
research tests, at a moderate price?

There is only one answer—

The new Haake  
**ROTOVISKO**

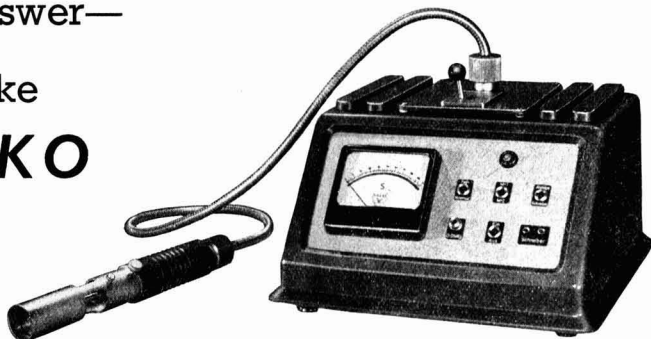

*write for full details to the  
sole agents and*

*distributors for the U.K.:- P. K. Dutt & Co. Ltd., 1-2 Alfred Place, London, W.C.1*  
Telephone : MUSEum 2454

## *Graesser Quality . . . .*

STANDARDISED TO MEET USER'S  
REQUIREMENTS UNDER EXPERT  
TECHNICAL CONTROL, CAREFUL  
SERVICE AND RELIABILITY BASED  
ON 40 YEARS EXPERIENCE

X Y L E N O L S  
PHENOL 40/41°C  
XYLENOL MIXTURES  
ORTHO/CRESOL 29/31°C  
ORTHO CRESOL MIXTURES  
PHENOL/CRESOL MIXTURES  
CRESYLIC ACID—ALL GRADES  
META-PARA-CRESOL MIXTURES

### **R. GRAESSER LTD.**

THE CHEMICAL WORKS · SANDYCROFT · NR. CHESTER  
TELEPHONE · HAWARDEN · 3104-5-6      TELEGRAMS · GRAESSER CHESTER





# UNIVERSAL MIXING MACHINES

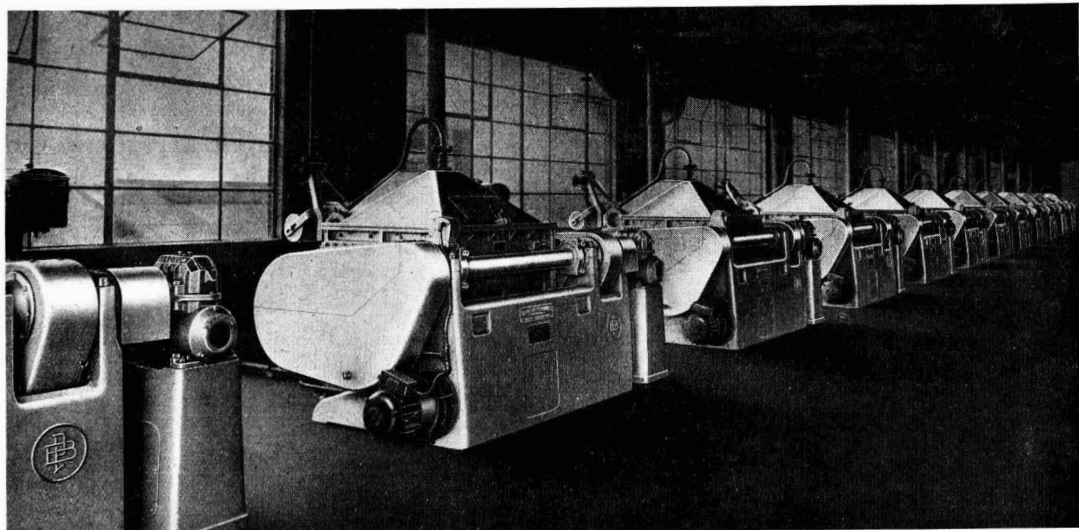

Whatever your mixing requirements may be Baker Perkins can offer you authoritative and objective guidance, deriving from 75 years experience in the vast field in which mixing forms part of industrial processes. They advise on familiar problems and experiment to solve new ones equally without fee or obligation.

★ This booklet illustrates and describes Universal Mixing Machines in types, sizes and capacities characteristic of the range. free on request.

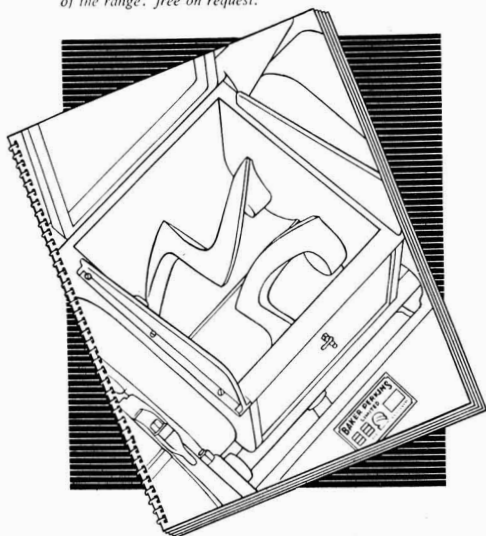

*A battery of Size 15½. Type VIII.  
Class B.B. Universal Mixers.*

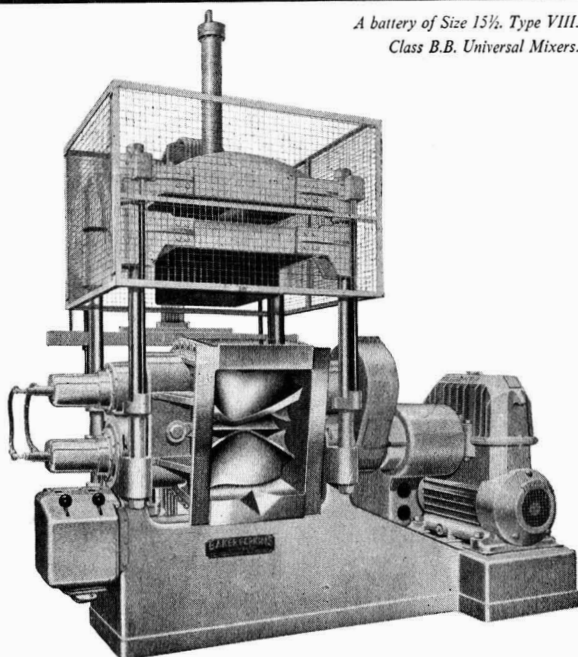

*Size 12 Universal Heavy Duty  
Mixer for Rubber and Plastics.  
Capacity per mix 9 Imp. gallons.  
H.P. 40.*

*Fully jacketed for temperature  
control and with pressure ram  
actuated hydraulically or pneu-  
matically as preferred.*

**BAKER PERKINS**  
*Engineers* LTD

WESTWOOD WORKS - PETERBOROUGH

... cannot imagine how I  
managed without Denso...

This is just one of the many customers who have written to us, singing the praises of DENSO. DENSO anti-corrosive products are saving industry thousands of pounds each year, protecting pipelines, cables and conduits, above and below ground, piers, bridges, structural steelwork and water mains. If Corrosion is YOUR problem—get in touch with DENSO.



whatever your corrosion problem—Consult  
**WINN & COALES LTD.**

Denso House, Chapel Road, London, S.E.27.

Telephone: GIPsy Hill 4247 (4 lines). Telegrams: Denselte, Westnor, London

## PETROLEUM-DERIVED AROMATIC SOLVENTS AND HYDROCARBON RESINS

### SOLVENT AR-310

|               |             |
|---------------|-------------|
| Boiling range | 159-176° C. |
| Aromaticity   | 95%         |
| Kauri Butanol | Above 90%   |

### SOLVENT AR-395

|               |             |
|---------------|-------------|
| Boiling range | 218-269° C. |
| Aromaticity   | 97%         |

Now available in bulk or drums ex stock.

OTHER CUTS AVAILABLE ON REQUEST, INCLUDING BOILING RANGES 177-211° C. & 232-285° C.

### PETROLEUM-DERIVED HYDROCARBON RESINS

of high light stability and compatibility with  
other synthetic resins.

Softening point about 100° C. ASTM method.

### ODOURLESS ALIPHATIC SOLVENT

thinner for odourless paints.

Boiling range about 175-210° C.

OTHER PRODUCTS CURRENTLY HANDLED IN BULK AND DRUMS INCLUDE:

N-BUTANOL · ISO-BUTANOL · ISO-OCTANOL · BUTYL ACETATE · XYLOL · ETHYLENE GLYCOL

Enquiries to:

**CHEMITRADE LTD., 17 STRATTON STREET, LONDON W.1.**

Telephone: GROsvenor 3422.

Cables: Multikem, London.

Telex: London 8694 Traforchem.

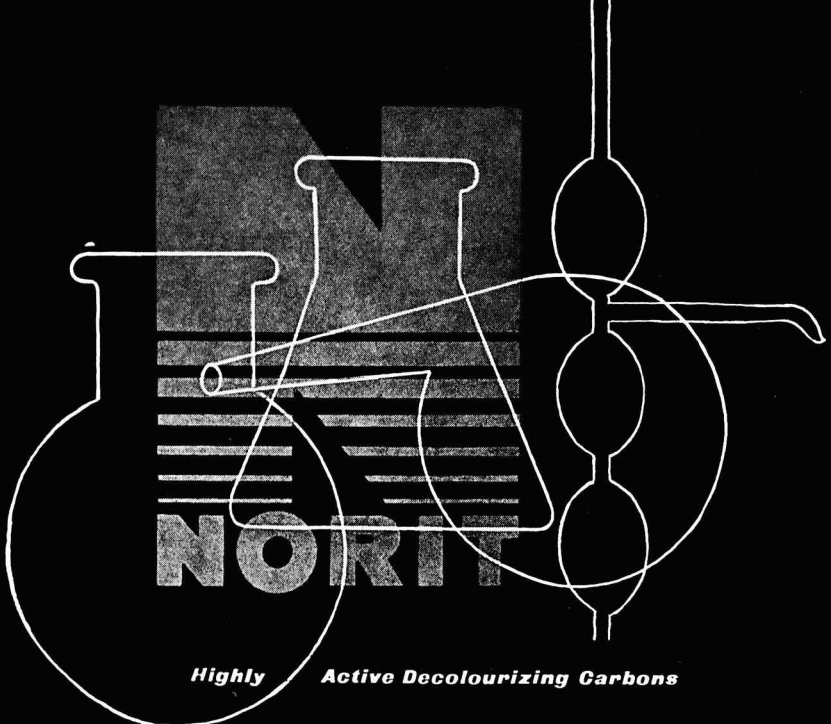

**Highly Active Decolourizing Carbons**

Decolourization and Purification  
of organic and inorganic chemicals for industrial  
and pharmaceutical purposes. Special granular grades for solvent  
recovery, separation of gas mixtures and distillates,  
or to act as a catalyst-carrier.

**United Norit Sales Corporation Ltd., Amsterdam**

Representation in United Kingdom:

Haller & Phillips Ltd - London E.C.2.  
14, Wool Exchange-Basinghall Street  
Telephone: MONarch 9041/2

# Classified Advertisements

**CLASSIFIED RATES:** All sections 5d. per word. Minimum 8/- . Three or more insertions 4d. per word. Box Number 2/- extra. Up to mid-day Tuesday for insertion same week.

**SEMI-DISPLAY:** 30/- per inch. Three or more insertions 25/- per inch.

**SUBSCRIPTION:** Annual Subscription of 52/6 brings 52 weekly copies of CHEMICAL AGE direct to your address from the printer (postage paid by the publishers), and a copy of CHEMICAL AGE YEAR BOOK.

**COMPANY MEETINGS AND REPORTS:** £12.12.0 per column. Three column measure (approximately 360 words).

---

## EDUCATIONAL

**A.M.I.CHEM.E.**—More than one-third of the successful candidates since 1944 have been trained by T.I.G.B. All seeking quick promotion in the Chemical and Allied Industries should send for the T.I.G.B. Prospectus. 100 pages of expert advice, details of Guaranteed Home Study Courses for A.M.I.Chem.E., B.Sc.Eng., A.M.I.Mech.E., A.M.I.Prod.E., C. & G., etc., and a wide range of Diploma Courses in most branches of Engineering. Send for your copy today—**FREE**. T.I.G.B. (Dept. 84), 29, Wright's Lane, London W.8.

---

## OFFICIAL APPOINTMENTS

### NORTH THAMES GAS BOARD

**A CHEMICAL ENGINEER** is required in the Research Laboratories at Watson House, Fulham, S.W.6. Applicants should possess a Degree in Chemical Engineering or Fuel Technology. The work includes research and design in the industrial gas utilisation field and requires a knowledge of heat transfer, fluid flow and a variety of unit operations.

The Laboratories have recently been modernised and extended and are responsible for research work for the Gas Industry throughout the country.

The appointment will be permanent and pensionable, and the starting salary will be within the range of £680-£900 per annum, according to age, qualifications and experience.

Applications, stating age, and giving full details of qualifications and experience, should be sent to the Staff Controller, North Thames Gas Board, 30, Kensington Church Street, W.8, quoting reference 666/436.

---

### UNITED KINGDOM ATOMIC ENERGY AUTHORITY GRADUATE ENGINEERS

Vacancies exist in the Production and Maintenance Departments of the various works of the Industrial Group of the Authority at Dounreay, Caithness; Chapelcross, Annan, Dumfriesshire; Calder and Windscale, Cumberland; Springfields, Preston; Capenhurst, Chester.

The work embraces a wide field of engineering and includes the operation or servicing of Reactors, Radiochemical Plants, Laboratories and Engineering Workshops. The posts call for a sound knowledge of Chemical, Mechanical, Electrical or Instrument Engineering.

Successful candidates will be trained for senior posts and will get a unique opportunity of acquiring knowledge and managerial experience in a new and expanding industry. The prospects are excellent and promotion depends entirely on the individual. Initial training will be given as required.

**QUALIFICATIONS:**—Applicants must possess a good engineering degree.

**SALARY:**—will be assessed within the scale £540 to £1,210 p.a.

A contributory pension scheme is in operation.

Housing schemes are in progress at all the Authority's Works.

Send a postcard asking for an application form and quoting reference 1,811 to The Recruitment Officer, U.K.A.E.A., I.G. Hq., Risley, Warrington, Lancs.

Closing Date—8th April, 1957.

---

## OFFICIAL APPOINTMENTS: continued

### NORTH THAMES GAS BOARD

**CHEMISTS AND PHYSICISTS** holding University degrees are required in the Laboratories at Watson House, Fulham, S.W.6. to undertake research work on the utilisation and design of domestic and industrial gas and coke appliances, particularly on cookers, water heaters, gas and coke fires, refrigerators, and industrial apparatus.

The Laboratories have recently been modernised and extended and are responsible for research work for the Gas Industry throughout the country.

The appointments will be permanent and pensionable and the starting salary will be within the range of £680-£900 per annum, according to age, qualifications and experience.

Applications should be sent to the Staff Controller, North Thames Gas Board, 30, Kensington Church Street, W.8. quoting reference 666/280 to reach him within ten days of the appearance of this advertisement.

---

### WALES GAS BOARD SENIOR INDUSTRIAL GAS ENGINEER, EASTERN SECTION

Applications are invited for a Senior Industrial Gas Engineer, Eastern Section, within the salary range of the Senior Officer's Grade "B" (£1,105-£1,265). Applicants should have had a wide experience in the application of gas for industrial purposes and experience in the design of construction and installation of industrial and commercial equipment.

Qualifications in Fuel Technology or any related subjects would be an advantage. Applicants should also have passed the Associated Membership Examination of the Institution of Gas Engineers.

The position is pensionable, and the successful applicant will be required to pass a medical examination.

Applications, stating age, education, qualifications and experience, together with the names of two referees, should be addressed to the undersigned not later than 6 April, 1957.

C. B. MAWER,  
Secretary.

2, Windsor Place,  
Cardiff.

---

## SITUATIONS VACANT

**CHEMICAL ENGINEER.** Consulting organisation handling Petroleum, Nuclear and Chemical Plants require a Senior Chemical Engineer. He should be capable of assuming full responsibility for all process design on large contracts including flow-chart development, design and specification of equipment, and liaison with client. Applicants must have had similar experience preferably in the field of petroleum processing. Please send full details of qualifications, experience and salary envisaged, to **HEAD WRIGHTSON PROCESSES LTD., 24-26, BALTIC STREET, E.C.1.**

*SITUATIONS VACANT: continued*

A **CHEMICAL ENGINEER** is required for a modern works engaged on the production of a metal from its ore.

The initial duties will be those of a member of the Development Staff investigating existing process procedures and plant. At a later date the duties will involve plant design and subsequent supervision of installation and maintenance as a member of the existing Engineering Staff.

Applicants should be between 25 and 45 years of age. Salary will be in accordance with qualifications and experience.

The post offers a five-day week, pension scheme, good working conditions and assistance for housing. In addition, there is the chance to live in pleasant surroundings, the works being near the sea and not in a large industrial town.

Apply to The Works Manager, Murex Limited, P.O. Box No. 5, Milford Haven.

**THE FIRE PROTECTION ASSOCIATION** has a vacancy for a **CHEMICAL ENGINEER OR CHEMIST** age 30 or under. After about six month's general experience the applicant will specialise in, and be responsible for the chemical aspects of the technical work. The Association is non-profit making, formed by fire insurance companies to study fire prevention technology, to publish recommendations and generally advise on fire protection both individually and through publication. Salary will be commensurate with qualifications and experience. Non-contributory pension scheme. Applications marked "Private" giving full particulars and salary required to the Secretary, 15 Queen Street, London, E.C.4.

**MECHANICAL ENGINEER**, for senior position required for design work on Petroleum, Chemical and Nuclear plants by London consulting organisation. B.Sc. and some industrial experience are minimum qualifications. Please send full particulars of qualifications, experience and salary envisaged, to **HEAD WRIGHTSON PROCESSES LTD., 24-26, BALTIC STREET, E.C.1.**

**CHEMICAL BUYER.** Large merchant company require junior buyer for purchasing department London. Knowledge of chemical sources of supply and export an advantage. Reply giving details of education, experience and present salary to Box 3530.

A well-known company in the south of England has a vacancy in its research laboratories for a young Graduate Chemist for laboratory work on unit chemical engineering operations. A good knowledge of physical and organic chemistry is required but industrial experience is unnecessary. The commencing salary offered will depend on age and qualifications but will not be less than £650 per annum. Applications to Box No. 3529.

*FOR SALE*

Brand New **COCHRAN** Vertical and **ECONOMIC** Self-contained **STEAM BOILERS** in stock, also all sizes reconditioned and guaranteed. List on request.

**STAINLESS STEEL TANKS, PANS, CONDENSERS, PLATES, VALVES AND COCKS.** Very wide selection.

4 new **ALUMINIUM CONDENSERS**, 14 ft. long, 2 ft. 3 in. dia., 386 tubes  $\frac{3}{8}$  in. o.d.

**FRED WATKINS (BOILERS) LTD.,  
COLEFORD, GLOS.  
Phone: Coleford 2271/2.**

**PHONE 98 STAINES**

3,000-gal. Stainless Steel Cylindrical Enclosed Tank.

26,500-gal. Sec. Steel Cylindrical Enclosed Tank.

6 ft. by 3 ft. diam. Stainless Steel Autoclaves.

40 ft. Stainless Steel Enclosed Elevator.

100-gal. Stainless Steel Jacketed Pan, 60 w.p.

'Porcelain' Ball Mill, approx. 18 in. by 18 in. diam.

'Z'- and Fin-Blade Mixers, Pumps, Hydros, Refiners, Conveyors Stackers, Loaders, Condensers, Crushers and Grinders.

**HARRY H. GARDAM & CO. LTD.**

*FOR SALE: continued*

**STAINLESS STEEL** Mixing Vat—200 gal. Water jacketed. **MIRACLE MILL**—Type 25, with blower and 35 h.p. S/Ring 3-phase motor and oil starter.

80 QRT. **PEERLESS** 4-speed 3 h.p. A.C. Bowl Mixer.

**SIFTER-MIXERS**—500/300/150/60 lb. capacity.

**REVOLVING DRUM**—6 ft. diam. by 2 ft. 4 in. wide.

**GRANITE EDGE RUNNER**—3 ft. 6 in. with two rollers.

**COPPER TILT PANS**—30 in. by 28 in. for 80 lb. w.p.

**MORTON** 20-gallon "Z" MIXER with motor.

**WINKWORTH MACHINERY LTD.,  
65 High Street, Staines (Telephone 1010).**

**600****FAT REFINING AND MANUFACTURING PLANT**

**LITTLE-USED COMPOUND LARD PLANT**, comprising: **VOTATOR** by A. JOHNSON, Model S.51A, capacity 3,000 lb./hr., with small Air Compressor by Bristol Pneumatic Tool Company, Model 303 V, driven by  $\frac{1}{2}$  h.p. motor mounted over Vertical Cylindrical Air Receiver. With Sterne Ammonia Compressor, No. 4628, 10-ton capacity, vee-belt drive to flywheel from 25 h.p. S/R motor 400/3/50, with Fan-cooled Galvanised Water-cooling Plant.

**CHILLING PLANT BY WILLIAM DOUGLAS & SONS LIMITED OF PUTNEY**, comprising Rotating Chilling Drum 5 ft. 1 in. face by approx. 2 ft. 9 in. diam., cored for cooling, gear driven by direct coupled 2 h.p. motor through Croft enclosed reduction gear. Drum supported on heavy cast-iron side frames and complete with take-off knife. Included is a Nicol Patent Mechanical Texturator by William Douglas with motor drive, Circulating Pump mounted on cast-iron under-bed and Douglas Nicol Atomiser direct coupled to motor on cast-iron under-bed.

**AMMONIA COMPRESSOR BY DOUGLAS**, type P.6, 6 in. by 6 in., 400 r.p.m., 130,000 BTU's, vee-belt drive to flywheel by 17 h.p. S/R motor, with all accessories including gauges, Horizontal Tubular Condensers, Evaporator, Ammonia Tank, Connecting Piping, Water-cooled Pumping Set and Tubular Cooling Water Condenser.

**ROTARY BELT-DRIVEN CHILLING MACHINE** with roll approx. 5 ft. 1 in. long by 2 ft. 9 in. diam., cored for brine cooling. Take-off Knife fitted.

Totally enclosed **CHURN OR DOUBLE-AGITATED MIXER** by HENRY ENGLE. Jacketed body approx. 5 ft. 6 in. long by 4 ft. wide by 4 ft. 6 in. deep. Two Vertical Agitators driven by S/R motor through flywheel enclosed gear.

**NEW AND UNUSED PORTABLE SYRUP PUMP** by **JOBSON & BECKWITH**, Rotan Model RT.32,  $1\frac{1}{4}$  in. suction and delivery with gunmetal gears and stainless steel shaft, capacity 6 g.p.m. when pumping thick syrup. Drive by 1 h.p. motor through reduction gear mounted on channel under-bed on tubular framework with bogie wheels for portability.

20 cwt. **SPEEDWAY PORTABLE DIAL TYPE PLATFORM WEIGHING MACHINE** by **VANDOME & HART LTD.** Visible dial scale graduated in 4 lb., quarters and hundredweight divisions. Platform 4 ft. by 4 ft. galvanised clad.

**HAND-OPERATED HYDRAULIC FORK LIFT TRUCK** BY **MONTGOMERY REID OF BASINGSTOKE**, Wheelabout Model, new 1955. Capacity 5 cwt. at 15 in. from heel of forks, and 6 cwt. at 10 in. from heel of forks. Mounted on three 10 in. by 2 in. solid rubber-tyred wheels.

**EMPIRE TYPE WIRE STITCHING MACHINE** BY **VICKERS-ARMSTRONGS**. Pedestal model, 16 in. throat, belt drive from electric motor.

**VARIOUS STEAM-JACKETED PANS, GALVANISED TANKS, ETC.**

**GEORGE COHEN SONS & CO. LTD.,  
WOOD LANE, LONDON, W.12,  
Tel.: Shepherds Bush 2070 and  
STANNINGLEY, NR. LEEDS  
Tel.: Pudsey 2241.**

**CHARCOAL, ANIMAL AND VEGETABLE**, Horticultural, burning, filtering, disinfecting, medicinal. Also lumps, ground and granulated. **THOMAS HILL-JONES, INVICTA WORKS, BOW COMMON LANE, LONDON, E.3 (TELEPHONE: EAST 3285).**

Carboy Stands. Carboy Carriers. 40 gal. one-man drum lifters Portable Rack for lifting and emptying carboys. **J. ABBEY LTD., WATTON, NORFOLK, PHONE WATTON 202.**

## FOR SALE: continued

**MORTON, SON AND WARD, LIMITED, STAINLESS STEEL VESSELS**

**VESSELS** of all shapes and sizes, jacketed or unjacketed—with stainless steel mixing gear to requirements; also stainless steel storage tanks and vacuum vessels.

“**MORWOOD**” “**U**”-shaped **TROUGH MIXERS**—up to 2 tons, in stainless steel, with agitators, scroll or paddle type, jacketed or unjacketed.

Stainless Steel **TROUGHS, TANKS** and **CYLINDERS** made to requirements.

These items can also be fabricated in mild steel.

**JACKETED PANS**

100g., 150g., and 200g., new, in mild steel, for 100 lb. p.s.i. w.p.—with or without mixing gear.

3 cwt. **TROUGH MIXERS** by **CHALMERS** and **GARDNER**—stainless steel-lined troughs.

50g., 75g. and 100g. heavy duty **MIXERS** by **FALLOWS** and **BATES**. Agitators driven through bevel gears from fast and loose pulley.

200g. cast-iron **JACKETED MIXING VESSEL** with nickel-chrome impeller type agitator driven through bevel gears from fast and loose pulley.

**AIR COMPRESSORS**

**THREE** 30 c.f.m. at 100 lb. pressure, water cooled, automatic overloads, with or without motors.

**AIR RECEIVERS MADE TO REQUIREMENTS. PUMPS** Selection of new **MONO** and second-hand Pumps in stock—2 in. to 5 in.

## Inquiries Invited.

**MORTON, SON AND WARD, LIMITED,  
WALK MILL,  
DOBCROSS, NEAR OLDHAM,  
Lancs.**

Phone Saddleworth 437

**600**

Horizontal Steam Jacketed **DRIER**—23 ft. by 4 ft. diam. Fitted revolving reel of ten 4 in. diam. tubes around central tube, steam heated. Intermediate paddles for agitation. Jacket w.p. 2 ats. With condenser, wet vacuum pump & fittings.

Horizontal Vacuum Drier—15 ft. 9 in. by 36 in. diam.  $\frac{1}{2}$  in. steel plate construction, with glanded steam tube and agitator gear pulley driven. Drier has two 12 in. by 8 in. outlets.

Stainless Steel Vacuum Mixer by Hardaker. Trough 47in. by 43 in. by 34 in. deep. Twin “Z” blades direct coupled to reduction gear. Domed cover 24 in. deep with 2 in. vacuum connection. Electrically operated tilting.

Double Trough Mixer by D. Thompson. Mild steel trough 35 in. by 45 in. by 39 in. deep. Twin “M”-shaped blades motorised 400/3/50. Separately motorised tilting.

36 in. diam. Centrifugal Oil Extractor by Broadbent. Pitless type. 3-point suspension. Mild steel basket 14 in. deep,  $\frac{1}{4}$  in. diam. perforations. Motorised 400/3/50.

16 Horizontal Cast-iron Plate and Frame **FILTER PRESSES**, forming 19 cakes 22 $\frac{1}{2}$  in. sq. by 1 in. Capstan closing gear with final hydraulic pressure.

50-gal. Aluminium Steam Jacketed Boiling Pan by A.P.V. 30 in. diam. by 24 in. with 1 $\frac{1}{2}$  in. bottom outlet. Welded aluminium jacket for 30 lb. W.P.

Four 40-gal. Open-top Steam Jacketed Boiling Pans by B.C.H. 25 in. diam. by 18 in. with pouring lip. Jacket suitable 60 lb. sq. in. W.P.

**NEW STAINLESS STEEL STORAGE TANKS AND VESSELS** with capacities ranging from 8 gallons to 1,000 gallons.

**NEW PORCELAIN- AND SILEX-LINED BALL MILLS** with capacities ranging from 9 gallons to 260 gallons.

**GEORGE COHEN SONS & CO. LTD.,  
WOOD LANE, LONDON, W.12.  
Tel.: Shepherds Bush 2070 and  
STANNINGLEY, NR. LEEDS.  
Tel.: Pudsey 2241.**

**FEW** Keith Blackman Galvanised Centrifugal Fan Units. Totally enclosed motors £25 each to clear. Bellangers, 306 Holloway Road, London, N.7 (North 4117).

**MIXERS**—1 Baker Hand-tilted Trough, 16 in. by 24 in. by 20 in. Fast and loose pulleys and clutch. “Z” blades.  
1 Ditto Power-tilted Trough, 30 in. by 20 in. by 24 in. Pulley drive and clutch. Four “L” blades.

**THOMPSON & SON (MILLWALL), LTD.,  
LONDON, E.14.  
TEL.: EAST 1844**

## WORK WANTED &amp; OFFERED

**PULVERISING** of every description of chemical and other materials. Collections, storage, deliveries. **THOMAS HILL JONES, LIMITED, INVICTA WORKS, BOW COMMON LANE, LONDON E.3 (TELEPHONE: EAST 3285).**

**INDUSTRIAL MACHINING**—Hydro, Filter and Grinder Bags made to any specification. Inquiries to:—

**MESSRS. YOUNG & EAST,  
4, NOREEN AVENUE,  
PRESTWICH, LANCs.  
TELE.: WHITEFIELD 3416.**

**CRUSHING, GRINDING, MIXING and DRYING for the trade.  
THE CRACK PULVERISING MILLS LTD.**

Plantation House  
Mincing Lane,  
London, E.C.2.

**GRINDING, CRUSHING AND GRADING**

**FINE GRINDING LTD.,  
BLACKHOLE MINE, EYAM  
TELEPHONE: EYAM 227**

## PATENTS &amp; TRADE MARKS

**KING'S PATENT AGENCY, LTD.,** (B. T. King, A.M.I.Mech.E., Patent Agent), 146a, Queen Victoria Street, London, E.C.4. **ADVICE** Handbook, and Consultation free. Phone: City 6161.

The Proprietor of British Patent No. 614,006 for “**A METHOD AND MEANS FOR PRODUCING LIQUID OXYGEN OR LIQUID AIR RICH IN OXYGEN**”, desires to enter into negotiations with a firm or firms for the sale of the patent or for the grant of licences thereunder. Further particulars may be obtained from Marks & Clerk, 57 & 58, Lincoln's Inn Fields, London, W.C.2.

The Proprietor of British Patent No. 574803, entitled “**Apparatus For The Treatment Of Blood**”, offers same for license or otherwise to ensure practical working in Great Britain. Inquiries to Singer, Stern & Carlberg, 14 E. Jackson Blvd., Chicago 4, Illinois, U.S.A.

**THE INDENT GAZETTE**

An average of 220 enquiries for goods from export merchant buyers, including Chemicals of all descriptions, appear weekly in The Indent Gazette. Specimen copy sent on application to **154 Fleet Street, London, E.C.4.**

**Classified Advertisements can be accepted for  
insertion up to 10 a.m. Tuesday for insertion  
in the same week.**

“*Fullersite*”

**SLATE FILLER**

**WHEREVER AN INERT FILLER  
IS REQUIRED FULLERSITE  
IS THE IDEAL MATERIAL**

**PENRHYN QUARRIES LTD.**

PORT PENRHYN, BANGOR, NORTH WALES

**LANKRO**

CHEMICALS LTD



CHEMICALS FOR  
THE  
LEATHER  
PLASTICS  
TEXTILE  
COSMETIC  
AND FUR  
INDUSTRIES

**ECCLES**

MANCHESTER

TELEPHONE  
ECCLES 5311-6

GRAMS LANKRO  
ECCLES MANCHESTER

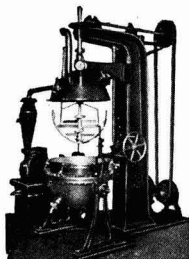

Steam jacketed copper Boiler and Mixers to tilt, with vacuum pump, and jet condenser. Cover and agitator raised by bevel gear and hand-wheel.

**COPPER  
PLANT**FOR THE  
CHEMICAL TRADE

STILLS  
RECTIFYING  
COLUMNS  
CONDENSERS

AUTOCLAVES · CALANDRIAS  
VACUUM PANS · BOILING PANS  
PIPEWORK COILS, ETC.

ESTABLISHED 1825

**BLUNDELL & CROMPTON LTD**

WEST INDIA DOCK ROAD · LONDON · E.14

Phone: East 3838 (3 lines)  
1408 and 4160

Grams: Blundell Phone  
London

**"REDAC"  
PRODUCTS**

ACID RESISTING  
EARTHENWARE

*Enquiries Welcomed***B. WHITAKER & SONS, LTD.**

ST. STEPHENS HOUSE, WESTMINSTER

Phone: Whitehall 3616

Works: ACCRINGTON, LANCs.

Grams: Bricavity, Parl, London

ACID RESISTING  
TILES · BRICKS  
ACID TOWER  
PACKINGS  
RINGS AND BALLS

Successfully used in

GAILLARD TOWERS · ACID OIL  
SETTLING TANKS · GAS WASHERS  
CHIMNEY LININGS · ASH SLUICES  
HYDROCHLORIC PICKLING TANKS  
ETC.



**SPECIALISTS  
IN ACID HANDLING**

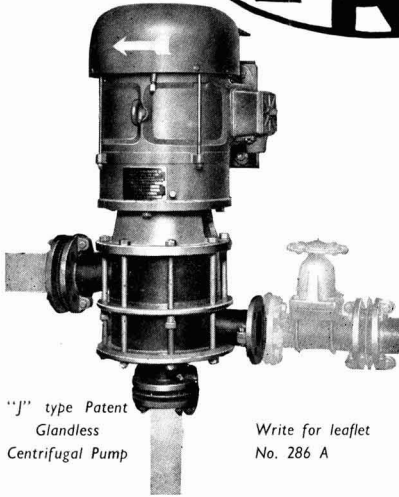

"J" type Patent  
Glandless  
Centrifugal Pump

Write for leaflet  
No. 286 A

- NO STUFFING BOX OR GLAND
- NO MECHANICAL SEAL
- NO RUBBING OR BEARING SURFACES IN CONTACT WITH THE ACID
- HOMOGENOUS FULLY CORROSION-RESISTANT MATERIALS USED THROUGHOUT

## GLANDLESS ACID PUMPS

The handling of Corrosive liquids and gases is but one facet of Kestner's activities. Complete process plants are supplied for the production of chemicals, foodstuffs, etc. Write for leaflet No. 283.

**KESTNER EVAPORATOR & ENGINEERING CO. LTD. 5 GROSVENOR GARDENS, LONDON, S.W.1**

# 14,000 GAS VALVES

This is the number of **DONKIN VALVES** sold **ANNUALLY**. Unmistakable evidence of their popularity and reliability. They are in use in all parts of the World where Gas Works exist.

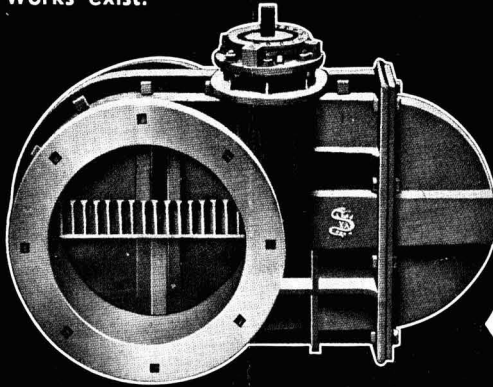

High Pressure Valve  
for pressures up to  
106 lbs.

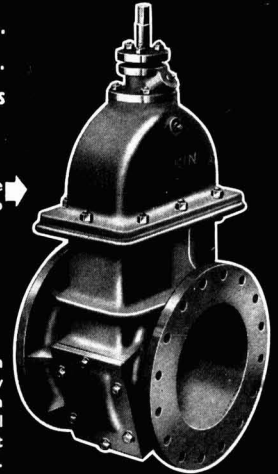

The Standard Donkin  
Rack and Pinion Low  
Pressure Valve which  
has been in general  
use for a great  
number of years.

**THE BRYAN DONKIN CO. LTD.**  
**GAS WORKS PLANT ENGINEERS · CHESTERFIELD**

