

# Chemical Age

MAJOR  
EXPANSION FOR  
COURTELLE

(page 421)

VOL. 84 No. 2149

17 September 1960

THE WEEKLY NEWSPAPER OF THE CHEMICAL INDUSTRY

COPY 2

## Gold from Old Bark

*From the root bark of apple trees comes the glucoside phloridzin. It is a rare substance to be thought of as an industrial chemical. Nevertheless B.D.H. has on occasion made the best part of half a ton of phloridzin, worth about £20,000, in a single year*

For the rarest of industrial fine chemicals the first choice is B.D.H.

BDH

FINE CHEMICALS  
FOR INDUSTRIAL USE

BRITISH DRUG HOUSES LTD. POOLE DORSET

LABORATORY CHEMICALS DIVISION

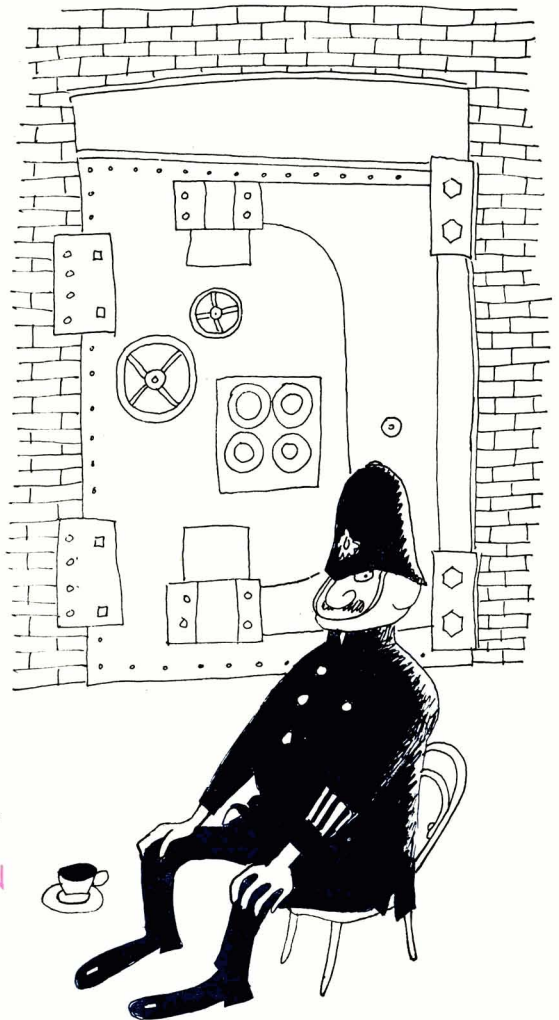

แผนกห้องสมุด กรมวิทยาศาสตร์  
กระทรวงอุตสาหกรรม

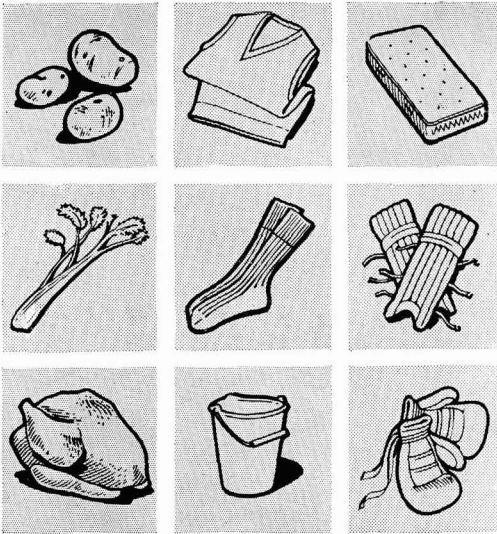

Pack your product in  
**'Spescopaks'**

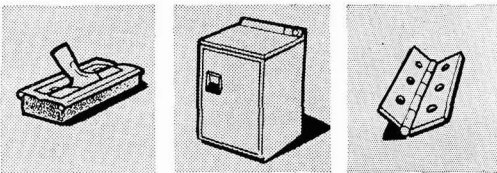

### — for faster sales and larger profits

'Spescopaks' are made from high-clarity 'Visqueen' polythene film. That means they are not only economical, but tough, flexible, waterproof and hygienic.

You'll find the unrivalled experience and resources of Spesco Developments Ltd., invaluable to your business. Spesco are one of the largest polythene converters in the United Kingdom, and helped to pioneer the adoption of polythene film in the packaging industry. They are specialists in the manufacture of carton, sack or drum liners for chemical and food trades.

#### Spesco offers you

- ★ Skilled technical service
- ★ Unrivalled experience and know-how
- ★ Top-quality packaging
- ★ Speedy deliveries
- ★ Highly competitive prices
- ★ Superb multi-colour printing
- ★ Shaped or novelty bags to order
- ★ Vast range of bag sizes flat and gusseted - plain or printed

Let Spesco create an individual pack for your product

Write now for samples and quotations to

Spesco Developments Ltd., Hanworth Lane, Chertsey or Tel: Chertsey 3411  
SP149

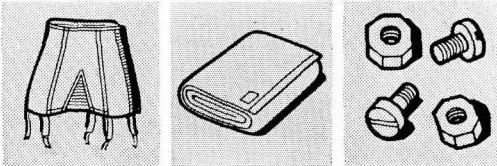

TYPE AI650

## MANUAL POLAROGRAPH

*An economically priced first step in Polarography*

Fast and accurate, reproducible plotting comparable in speed with recording types, but free from superimposed oscillations.

Compensation for effects due to large interfering reductions and cell capacity. Click-stop voltage change in multiples of 10 mV. Complete with stand, and galvo if required.



Tel. Camberley 3401

**SOUTHERN INSTRUMENTS LIMITED**

Analytical Instruments Department  
Camberley Surrey England

### Hydrometers...

PLAIN AND COMBINED FORMS.  
PRECISION TYPES FOR SPECIFIC  
GRAVITY, DENSITY AND ALL  
ARBITRARY SCALES.

MADE TO I.P., B.S., S.T.P.T.C.  
AND A.S.T.M. SPECIFICATIONS.

**ZECOL**  
REG. TRADE MARK

**ZECOL**  
REG. TRADE MARK

EST.  
1888

### Thermometers...

HIGH-PRECISION INSTRUMENTS  
FOR SCIENTIFIC RESEARCH—  
ANSCHUTZ, CALORIMETER AND  
SECONDARY STANDARDS.

Combined form  
A.P.I. Hydrometer

Instruments N.P.L. Certified if required

**G. H. ZEAL LTD**

Lombard Road, Morden Road, London, S.W. 19

'PHONE:  
LIBERTY 2283/4/5/6

'GRAMS:  
ZEALDOM, SOUPHONE, LONDON



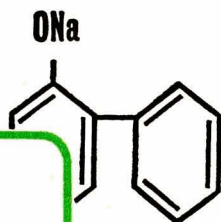
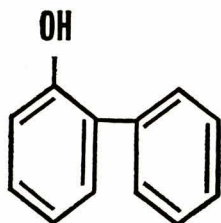

## CARDS ON THE TABLE

Whatever your business — textiles or timber, adhesives or apples, paper or paint, hide-treatment or house-building — you'll find I.C.I.'s 'Topane' and 'Topane' WS bactericides are the best you can buy. We make no idle boasts — we simply put our cards on the table.

This is the table which compares 'TOPANE' with four other bactericides in common use

	Safety and Ease of Application (Max. 20)	Germicidal Efficiency (Max. 20)	Lack of Toxicity (Max 20)	Persistence (Max. 20)	Economy of Price (Max. 20)	(Max. 100)
Old type Non-Phenolic	10	2	10	1	20	43
Modern High Efficiency Non-Phenolic	12	20	1	20	4	57
Modern Phenolic Derivative (1)	16	9	14	15	8	62
Modern Phenolic Derivative (2)	15	12	10	17	15	69
'TOPANE'	20	11	20	12	12	75

'Topane' (I.C.I.'s brand of ortho phenylphenol) is soluble in organic solvents. It provides a valuable base for household and industrial disinfectants, for it extends their range of bactericidal effectiveness. Other specific formulations — for example, for the treatment of wet and dry rot in timber — may be economically based on 'Topane'.

'Topane' WS (I.C.I.'s brand of sodium ortho phenylphenate) is the water-soluble grade of 'Topane'. It is valuable wherever health considerations call for a water-soluble germicide of low toxicity—e.g., in paper impregnation, cleaning ships' meat-cargo holds, etc.

Both 'Topane' and 'Topane' WS are supplied as non-dusting, free-flowing, safe-to-handle flakes.

For further information write to your nearest I.C.I. Sales Office or to

IMPERIAL CHEMICAL INDUSTRIES LTD., LONDON, S.W.1



# INDEX TO ADVERTISERS

The first figures refer to advertisements in Chemical Age Directory & Who's Who, the second to the current issue

Page	Page	Page	Page	Page	Page
127	A.P.V. Co. Ltd., The	---	180	British Tar Products Ltd.	---
154	Acalor (1948) Ltd.	---	---	British Thomson-Houston Co. Ltd., The	---
109	Accrington Brick & Tile Co. Ltd., The	---	207	British Titan Products Co. Ltd.	---
---	Aerox Ltd.	---	---	British Visqueen Ltd.	---
---	African Pyrethrum Technical Information Centre	---	303	Broadbent, Thomas, & Sons Ltd.	---
234	Air Products Gt. Britain Ltd.	---	151	Brotherhood, Peter, Ltd.	---
124	Air Trainers Link Ltd.	---	---	Brough, E. A., & Co. Ltd.	---
163	Albany Engineering Co. Ltd., The	---	---	Bryan Donkin Co. Ltd., The	---
---	Alchemy Ltd.	---	---	Bulwark Transport Ltd.	---
114	Alginate Industries Ltd.	---	178	Burnett & Rolfe Ltd.	---
132	Allen, Edgar, & Co. Ltd.	---	160	Bush, W. J., & Co. Ltd.	---
178	Allen, Frederick & Sons (Poplar) Ltd.	---	---	Buss Ltd.	---
162	Allis-Chalmers Great Britain Ltd.	---	165	Butterfield, W. P. Ltd.	---
---	Alto Instrumenten (Gt. Britain) Ltd.	---	---	Butterworths Scientific Publications	---
---	Alumina Co. Ltd., The	---	---	Callow Rock Lime Co. Ltd., The	---
186	Anglo-Dal Ltd.	---	254	& 262 Calmic Engineering Co. Ltd.	---
---	Anthony, Mark, & Sons Ltd.	---	---	Carless, Capel, & Leonard Ltd.	---
191	Armour Hess Chemicals Ltd.	---	---	Catterson-Smith, R. M., Ltd.	---
---	Ashmore, Benson, Pease & Co. Ltd.	---	182	Causeway Reinforcement Ltd.	---
---	Associated Electrical Industries Ltd.	---	248	Cawley Plastics Ltd.	---
---	Motor & Control Gear Division	---	---	Chappell, Fred, Ltd.	438
---	Associated Electrical Industries Ltd.	---	---	Chemical Age Enquiries	443 & 444
---	Turbine-Generator Division	---	---	Chemical Construction (G.B.) Ltd.	---
183	Associated Lead Mfrs. Ltd.	---	---	Chemical & Insulating Co. Ltd., The	---
G/Card	Audley Engineering Co. Ltd.	---	120	Chemical Workers' Union	---
---	Automotive Products Ltd.	---	---	Chemicals & Feeds Ltd.	406
---	B.S.A. Small Tools Ltd.	---	---	Chemolimpex	---
---	B.T.R. Industries Ltd.	---	---	Christy & Norris Ltd.	---
128	Baker Perkins Ltd.	414	146	Ciba (A.R.L.) Ltd.	---
---	Baldwin Instrument Co.	---	---	Ciba Clayton Ltd.	---
161	Balfour, Henry, & Co. Ltd.	---	---	Clech Ltd.	---
---	Balfour Group of Companies, The	---	152	Clenco Limited	---
164	Barclay Kellett & Co. Ltd.	---	---	Classified Advertisements	441 & 442
174	Barytes (Shielding Products) Ltd.	---	171	Claydon, Son & Co. Ltd.	---
---	Begg, Cousland & Co. Ltd.	---	126	Clydesdale Chemical Co. Ltd.	410
---	Bellingham & Stanley Ltd.	---	---	Cohen, George, Sons & Co. Ltd.	440
---	Belliss & Morcom Ltd.	---	129	Cole, R. H., & Co. Ltd.	---
---	Bennett, H. G., & Co. (Gloves) Ltd.	---	---	Colt Ventilation Ltd.	409
153	Bennett, Sons & Shears Ltd.	---	---	Combustion Chemicals Ltd.	---
G/Card	Berk, F. W., & Co. Ltd.	---	181	Comet Pump & Eng. Co. Ltd., The	---
126	Black, B., & Sons Ltd.	---	---	Consolidated Zinc Corporation Ltd.	---
2	Blackman, Keith, Ltd.	---	---	Constable & Co. Ltd.	---
---	Blaw Knox, Chemical Engineering Co. Ltd.	---	G/Card	Constantin Engineers Ltd.	---
115	Blundell & Crompton Ltd.	408	---	Constructors, John Brown, Ltd.	---
---	Boby, William, & Co. Ltd.	---	---	Controlled Convection Drying Co.	---
---	Borax & Chemicals Ltd.	---	---	Cooke, Troughton & Simms Ltd.	---
193	Borax Consolidated Ltd.	---	---	Coulter Electronics Ltd.	---
4	Boulton, William, Ltd.	---	---	Cromil & Piercy Ltd.	---
---	Braby, Frederick, & Co. Ltd.	---	---	Crosfield, Joseph, & Sons Ltd.	---
---	Brent, Peter, Ltd.	---	121	Crow Carrying Co. Ltd., The	---
248	Bristol Piping Co. Ltd., The	---	---	Cruikshank, R., Ltd.	---
117	British Acheson Electrodes Ltd.	---	214	Curran, Edward, Engineering Ltd.	---
---	British Association of Chemists	---	205	Cyanamid of Great Britain Ltd.	407
---	British Carbo Norit Union Ltd.	---	---	Cyclo Chemicals Ltd.	---
---	British Ceca Co. Ltd., The	Cover iv	114	Cyclops Engineering Co. Ltd., The	---
195	British Celanese Ltd.	415	---	Cygnat Joinery Ltd.	---
---	British Drug Houses Ltd., The	Front Cover	---	Dalglish, John, & Sons Ltd.	---
---	British Ermeto Corporation Ltd.	---	140	Danks of Netherton Ltd.	---
Spine	British Geon Ltd.	---	159	Davey & Moore Ltd.	---
252	British LaBour Pump Co. Ltd.	---	166	Davey, Paxman & Co. Ltd.	---
---	British Lead Mills Ltd.	---	---	Distillers Co. Ltd., The	---
---	British Resin Products Ltd.	---	197	Distillers Co. Ltd., The (Chemical Div.)	---
156	British Rototherm Co. Ltd., The	---	---	Distillers Co. Ltd., The (Industrial Group)	---
141	British Steam Specialties Ltd., The	---	143	Dorr-Oliver Co. Ltd.	---
---	British Sulphur Corporation Ltd., The	---	---	Doulton Industrial Porcelains Ltd.	---
---	---	---	---	Dowling Lime & Stone Co. Ltd.	---
---	---	---	---	Dring & Fage Ltd.	---
---	---	---	---	Drummond Patents Ltd.	---
---	---	---	---	Dryden, T., Ltd.	---
---	---	---	---	Dunlop Rubber Co. Ltd. (G.R.G. Dunclad)	416
---	---	---	---	E.C.D. Ltd.	---
---	---	---	---	Electric Resistance Furnace Co.	---
---	---	---	---	Electro-Chemical Engineering Co. Ltd.	---
---	---	---	---	Electrothermal Engineering Ltd.	---
---	---	---	---	Elga Products Ltd.	---
---	---	---	---	Book Mark Elliott, H. J., Ltd.	---
---	---	---	---	Elliott Brothers (London) Ltd.	---
---	---	---	---	Elmatic	---
---	---	---	---	Engelhard Industries Ltd. (Baker Platinum Division)	---
---	---	---	---	115 & 165 English Glass Co. Ltd., The	---
---	---	---	---	G/Card Erinoid Ltd.	---
---	---	---	---	Evans, Joseph, & Sons (Wolverhampton) Ltd.	---
---	---	---	---	Evered & Co. Ltd.	---
---	---	---	---	Farnell Carbons Ltd.	438
---	---	---	---	Fawcett, Preston & Co. Ltd.	---
---	---	---	---	150 Feltham, Walter H., & Son Ltd.	---
---	---	---	---	186 Ferris, J. & E., Ltd.	416
---	---	---	---	220 Ferrostatics Ltd.	---
---	---	---	---	Fibrolene	---
---	---	---	---	Fielden Electronics Ltd.	---
---	---	---	---	147 Film Cooling Towers (1925) Ltd.	---
---	---	---	---	113 Flight Refuelling Ltd.	---
---	---	---	---	133 Foster Instrument Co. Ltd.	---
---	---	---	---	Foxboro-Yoxall Ltd.	---
---	---	---	---	Foyle, W. & G., Ltd.	---
---	---	---	---	208 Fullers' Earth Union Ltd., The	---
---	---	---	---	G.O. Parachute Co. Ltd.	---
---	---	---	---	Gallenkamp, A., & Co. Ltd.	---
---	---	---	---	Gas Council, The	---
---	---	---	---	Geigy Co. Ltd., The	---
---	---	---	---	General Precision Systems Ltd.	---
---	---	---	---	Girdlestone Pumps Ltd.	---
---	---	---	---	Glass Manufacturers' Federation	---
---	---	---	---	Giusti, T., & Son Ltd.	---
---	---	---	---	148 Glebe Mines Ltd.	---
---	---	---	---	Goodburn Plastics Ltd.	---
---	---	---	---	Goodyear Pumps Ltd.	---
---	---	---	---	155 Graviner Mfg. Co. Ltd.	---
---	---	---	---	185 Glazebrook, M. & W., Ltd.	---
---	---	---	---	182 Greeff, R. W., & Co. Ltd.	---
---	---	---	---	Halex (Bex Industrial)	---
---	---	---	---	110 Haller & Phillips Ltd.	---
---	---	---	---	144 Harris (Lostock Gralam) Ltd.	436
---	---	---	---	Hathernware Ltd.	---
---	---	---	---	6 Haworth, F. (A.R.C.), Ltd.	---
---	---	---	---	Hearson, Charles, & Co. Ltd.	---
---	---	---	---	112 Heathway Machinery Co. Ltd.	---
---	---	---	---	Helmets Ltd.	---
---	---	---	---	Herbert, Alfred, Ltd.	---
---	---	---	---	149 Hercules Power Co. Ltd.	---
---	---	---	---	Hodgson, Richard, & Sons	---

(Continued on page 408)

## CHEMICALS AND FEEDS LIMITED

ADELAIDE HOUSE, KING WILLIAM STREET, LONDON, E.C.4  
Tel.: Mansion House 9621 (3 lines) Cables: 'Chemifeed' London

# BENTONITE

Associated with: P. Leiner & Sons (Wales) Ltd., The Glamorgan Alkali & Acid Co. Ltd., and other U.K. and Overseas manufacturers.

## SAFETY FIRST

### THE "OLDBURY" PATENT CARBOY DISCHARGER

will empty and elevate up to 50 feet the contents of any carboy, bottle or vessel, and complies with all the conditions of the Factory Act of 1937

## KESTNER'S

5, Grosvenor Gardens, Westminster, London, S.W.1



# How you can determine if ultraviolet light is degrading your product

If your product discolours, becomes brittle or otherwise breaks down on exposure to sunlight, it may be due to ultraviolet radiation from the sun. Suitable application of CYASORB\* UV Light Absorbers will provide lasting protection against such degradation. We have a very simple method that allows you to determine whether ultraviolet light degradation is your problem: if you will post us the coupon at the bottom of this page, we will send you two letter-size sheets of cellulose acetate. One is essentially transparent to visible and ultraviolet light. The other, containing 0.55 per cent CYASORB UV 24 Light Absorber, is opaque to ultraviolet light but transmits visible light.

Cover duplicate samples of your material with these two sheets, and expose them to the sun. If you wish to accelerate the test, use a Fade-Ometer. By examination of your samples after exposure, you will be able to judge if product degradation due to ultraviolet rays has occurred. And you will see demonstrated the exceptional effectiveness of CYASORB UV Light Absorbers. These Absorbers are available in different forms. Manufacturers of polyester, polystyrene, vinyl and surface coatings throughout the world are improving their products with them. You, too, may be able to use our Cyasorb products to your advantage. Send for your test kit today!

\* Trademark



## CYANAMID OF GREAT BRITAIN LIMITED

(General Chemicals Division)

BUSH HOUSE · LONDON · WC2

General Chemicals Division  
Cyanamid of Great Britain Limited,  
Bush House · London · WC2

Please send me, without obligation, my Free Cyasorb Test Kit.

Name and title \_\_\_\_\_

Company \_\_\_\_\_

Address \_\_\_\_\_

City and country \_\_\_\_\_

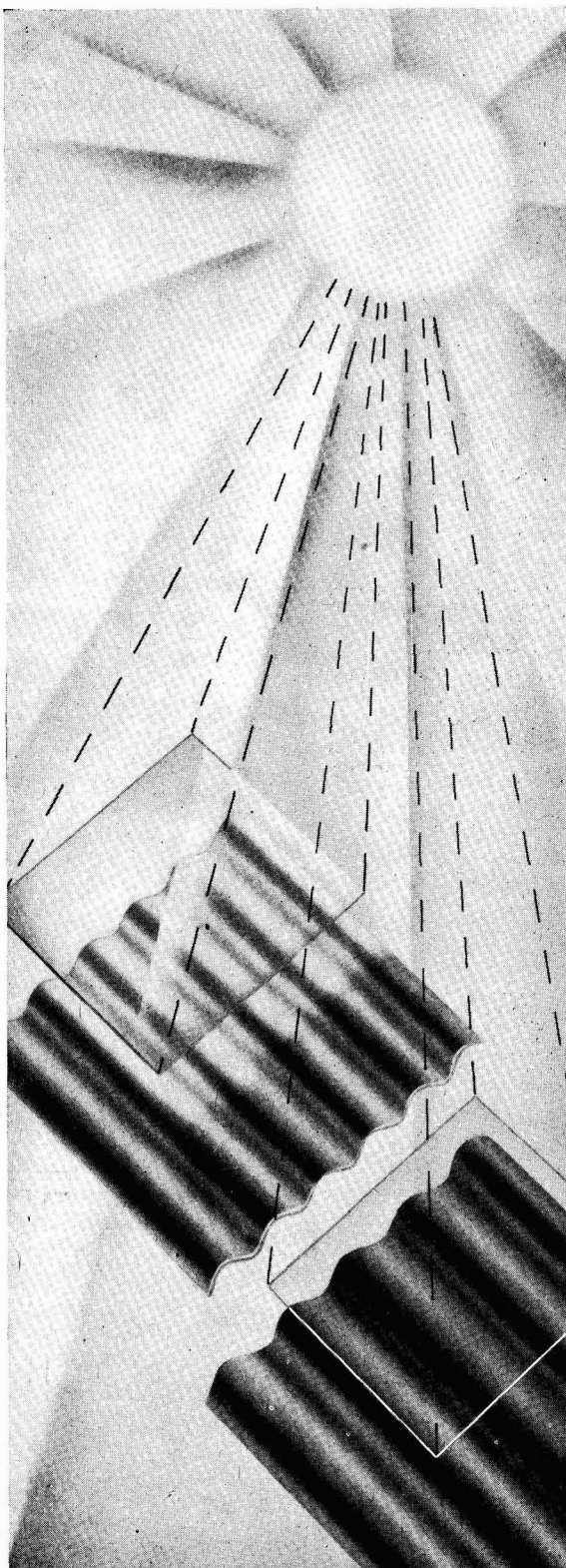

# INDEX TO ADVERTISERS

The first figures refer to advertisements in Chemical Age Directory & Who's Who, the second to the current issue

Page	Page	Page	Page	Page	Page
165	Holden, Chris., Ltd.	120	Middleton & Co. Ltd.	154	S.P.E. Company Ltd.
	Humphreys & Glasgow Ltd.		Minerale Import und Export GmbH		Saint-Gobain
139	Huntingdon, Heberlein & Co. Ltd.		Mirrlees Watson Co. Ltd., The	126	Sandiacre Screw Co. Ltd., The
	I.C.I. (Billingham)		Mirvale Chemical Co., Ltd., The		Saunders Valve Co. Ltd.
	I.C.I. Catalysts		Mitchell, L. A., Ltd.		Scientific Design Co. Inc.
	I.C.I. General Chemicals Division	157	Mitchell Cotts Co. Ltd.	164	Scottish Tar Distillers Ltd.
	I.C.I. Ltd. Heavy Organic Chemicals	405 & 412	108 Mond Nickel Co., Ltd., The		Sharples Centrifuges Ltd.
	I.C.I. Metals Titanium D.		115 Monkton Motors Ltd.	3	Sheepbridge Equipment Ltd.
	I.C.I. Plastics—Darvic		Monsanto Chemicals Ltd.		Shell Chemical Co. Ltd.
	I.C.I. Plastics—Fluon	413	Morgan Refractories Ltd.		Shell-Mex & B.P. Ltd.
	I.C.I. Ltd. (Plastics Division), Corvic		Moritz Chemical Engineering Co. Ltd.		Shell Industrial Oils
	I.C.I. (Florube) Ltd.		National Coal Board		Shipping Studies Ltd.
168	Infra Red Development Co. Ltd., The		National Industrial Fuel Efficiency Service		Siebe, Gorman & Co. Ltd.
173	International Furnace Equipment Co. Ltd., The	106	Neckar Water Softener Co. Ltd.		Sifam Electrical Instrument Co. Ltd.
	Isopad Ltd.	411	137 Negretti & Zambra Ltd.	34	Simon, Richard, & Sons Ltd.
142	Jackson, J. G., & Crockatt Ltd.		Newnes, George, Ltd.		Smith, Leonard (Engineers) Ltd.
167	Jenkins, Robert, & Co. Ltd.		Nitrate Corporation of Chile Ltd.		Sipon Products Ltd.
	Johnson, Matthew & Co. Ltd.		Nordac Ltd.		Sojuzchimexport
134	Johnsons of Hendon Ltd.		Northgate Traders (City) Ltd.	250	Southern Instruments Ltd.
	Jones & Stevens Ltd.		Nuovo Pignone		Spence, Peter, & Sons Ltd.
159	K.D.G. Instruments Ltd.		Nu-Swift Ltd.	167	Spencer Chapman & Messel Ltd.
184	K.W. Chemicals Ltd.	417	159 Odoni, Alfred A., & Co. Ltd.		Stanfield & Carver
	Kaylene (Chemicals) Ltd.		G/Card Oil & Colour Chemists' Association	302	Stanton Instruments Ltd.
158	Kellie, Robert, & Sons Ltd.		144 Optical-Mechanical (Instruments) Ltd.		Staveley Iron & Chemical Co. Ltd.
	Kellogg International Corporation		Orthos (Engineering) Ltd.	118	Steel Drums Ltd.
136	Kernick & Son Ltd.		G/Card P.G. Engineering Ltd.		Steele, J. M., & Co. Ltd.
301	Kestner Evaporator & Engineering Co. Ltd.		Palfrey, William, Ltd.		Stockdale Engineering Co. Ltd.
	Kestner Evaporator & Engineering Co. Ltd. (Keebush)	438	8 Paterson Engineering Co. Ltd., The		Sturge, John & E., Ltd.
	Kestner (Industrial Safety) Ltd.	406	Peabody Ltd.		Stutcliffe Speakman & Co. Ltd.
116	Kleen-eze Brush Co. Ltd., The		Penhryn Quarries Ltd.	140	Synthite Ltd.
	Kleen-eze Brush Co. Ltd., The		201 & 265 Permutit Co. Ltd., The	134	"T.P." Chemical Engineering Co. Ltd.
184	Laboratory Apparatus & Glass Blowing Co.		G/Card Petrocarbon Developments Ltd., The	169	Taylor Stainless Fittings Co. Ltd., The
	Langley Alloys Ltd.		Plastic Constructions Ltd.	223	Taylor Rustless Metals Ltd.
112	Lankro Chemicals Ltd.		213 Plastic Filters Ltd.		Tempair Ltd.
203	Laporte Chemicals Ltd.	435	168 Platon, G. A., Ltd.	148	Thermal Syndicate Ltd., The
122	Leek Chemicals Ltd.		238 Podmores (Engineers) Ltd.		Thermo Plastics Ltd.
	Leigh & Sons Metal Works Ltd.		243 Polysius Ltd.	174	Titanium Metal & Alloys Ltd.
	Lennig, Charles & Co. (Great Britain) Ltd.		246 Pool, J. & F., Ltd.	141	Towers, J. W., & Co. Ltd.
	Lennox Foundry Co. Ltd.	Cover iii	Pott, Cassels & Williamson Ltd.	241 & 256	Tylors of London Ltd.
142	Light, L., & Co. Ltd.		Potter, F. W., & Soar Ltd.		Unicome Co. Ltd., The
111	Lind, Peter, & Co. Ltd.		236 Powell Duffryn Carbon Products Ltd.	188	Unifloc Ltd.
126	Liquid Solid Separations Ltd.	Cover iv	Power-Gas Corporation Ltd.		Univer Ltd.
Back	Cover London Aluminium Co. Ltd., The		Prat-Daniel (Stanmore) Ltd.		Union Carbide Ltd.
176	London Sand Blast Decorative Glass Works Ltd., The		Premier Colloid Mills Ltd.		Unit Superheater & Pipe Co. Ltd., The
	Longman Green & Co. Ltd.		123 Pressoturn Ltd.	172	United Filters & Engineering Ltd., The
144	Longworth Scientific Instruments Co.		152 Price Stutfield & Co. Ltd.		G/Card Universal-Matthey Products Ltd.
165	Lord, John L., & Son		Prodorite Ltd.	176	W.E.X. Traders Ltd.
	Loughborough Glass Co. Ltd.		Price's (Bromborough) Ltd.	177	Walker, P. M., & Co. (Halifax) Ltd.
	Lurgi Verwaltung GmbH.		Pyrene Co. Ltd.	179	Walker, George, & Son Ltd.
150	McCarthy, T. W., & Sons		Pyrene-Panorama Ltd.		Ward, Thomas W., Ltd.
	MacLellan, George, & Co. Ltd.		156 Pyrometric Equipment Co. Ltd., The		Warren-Morrison Ltd.
	McMurray, F. J.		Q.V.F. Ltd.	136	Watson, Ludlow, & Co. Ltd.
175	Maine, B. Newton, Ltd.		Quickfit & Quartz Ltd.		Wellington Tube Works Ltd.
116	Manesty Machines Ltd.		142 Reade, M. G.	225	Whitaker, B., & Sons Ltd.
199	Marchon Products Ltd.		226 Reads Ltd.		Widnes Foundry & Engineering Co. Ltd.
	Marston Excelsior Ltd.		146 Rediweld Ltd.	244	Wilcox, W. H., & Co. Ltd.
	May & Baker Ltd.	439	Rheem Lysaght Ltd.	160	Wilkinson, James, & Son Ltd.
Front	Cover Metal Containers Ltd.		Richardson Scale Co. Ltd.		Williams, G., Engineering Co.
	G/Card Metalock (Britain) Ltd.		Richardson Welding Co. Ltd.	130	Williams & James (Engineers) Ltd.
152	Metcalf & Co.		Rose, Downs & Thompson Ltd.	130	Wood, Harold, & Sons Ltd.
	Metropolitan-Vickers Electrical Co. Ltd.		228 Rosin Engineering Co. Ltd.	172	Worcester Royal Porcelain Co. Ltd., The
			Ross Ensign Ltd.		Wynn (Valves) Ltd.
			180 Rotameter Manufacturing Co. Ltd.	138	Yorkshire Tar Distillers Ltd.
					Young, A. S., & Co.
				138	Zeal, G. H., Ltd.
					Cover ii

## COPPER PLANT

for the  
CHEMICAL TRADE

Established 1825

**BLUNDELL & CROMPTON**  
LIMITED  
WEST INDIA DOCK ROAD,  
LONDON, E.14

Phone : East 3838 (3 lines) 1408 & 4160  
Grams : Blundell Phone London

STILLS

RECTIFYING COLUMNS  
CONDENSERS

Autoclaves . Calandrias  
Vacuum Pans . Boiling Pans  
Pipework . Coils . Etc.



**FLAME TRAPS**  
TO OUR OWN  
DESIGN AND SIZE  
IN ANY METAL

**RICHMOND WELDING COMPANY**

ESTABLISHED 1929

RICHMOND ROAD, BRADFORD 7

TELEPHONE 25405



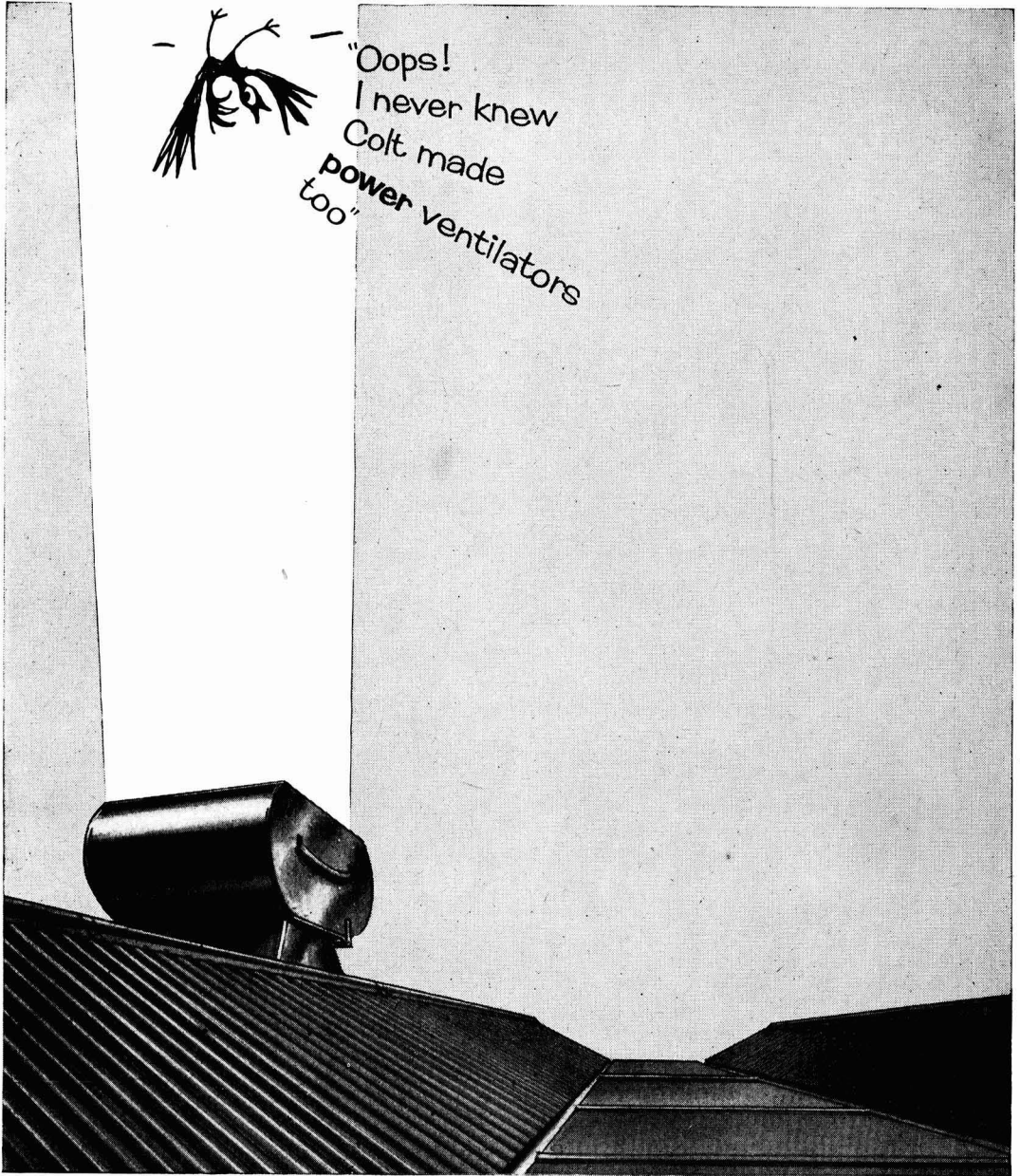

They do! For Colt have a ventilator, natural or powered, to meet every kind of problem—including a range of high powered ventilators such as the Upward Discharge unit shown here. Let the Colt Ventilation Service advise you. Powered or natural, or a combination of both—the Colt engineer will tell you which system is best and most economical for you. Send for a free manual to Dept. 37



The power behind natural ventilation and naturally behind powered ventilation too!



COLT VENTILATION LIMITED · SURBITON · SURREY · Telephone: ELMbridge 0161

VISIT OUR STAND D.46 AT THE FACTORY EQUIPMENT EXHIBITION

*is  
yours  
a*

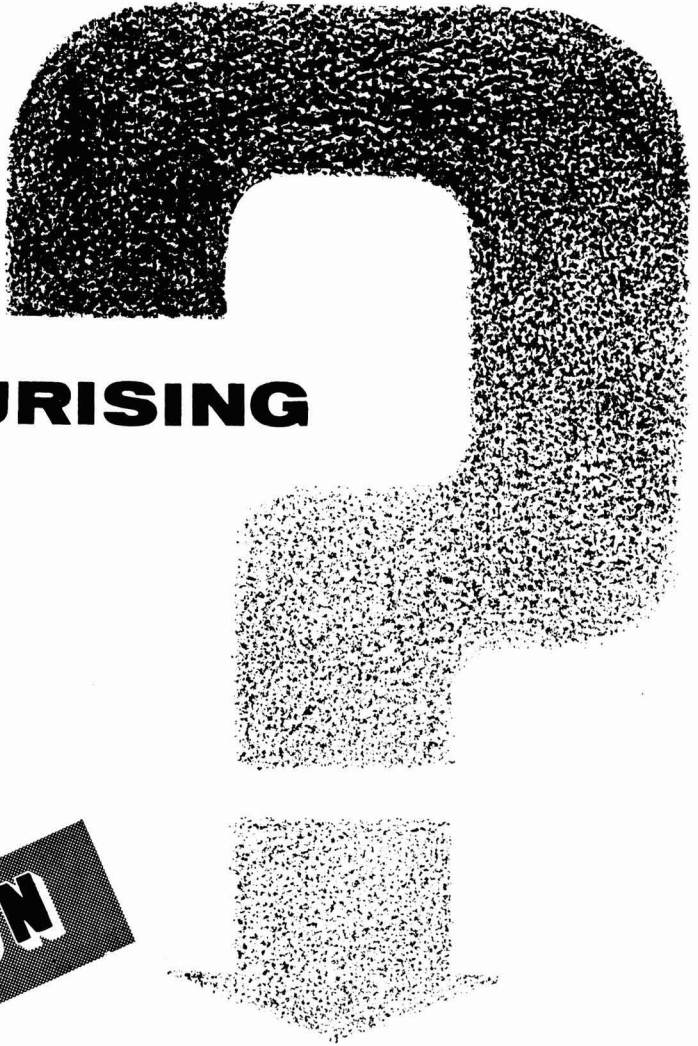

**DECOLOURISING**  
*problem*

*...specify*

**ACTIBON**

THE  
HIGHLY ACTIVATED  
DECOLOURISING  
CARBON

its THE  
**CLEAR SOLUTION**



**THE CLYDESDALE CHEMICAL CO., LTD.**

142 QUEEN STREET,  
Phone Central 5247-8

GLASGOW, C.I.  
Grams "Cactus" Glasgow.

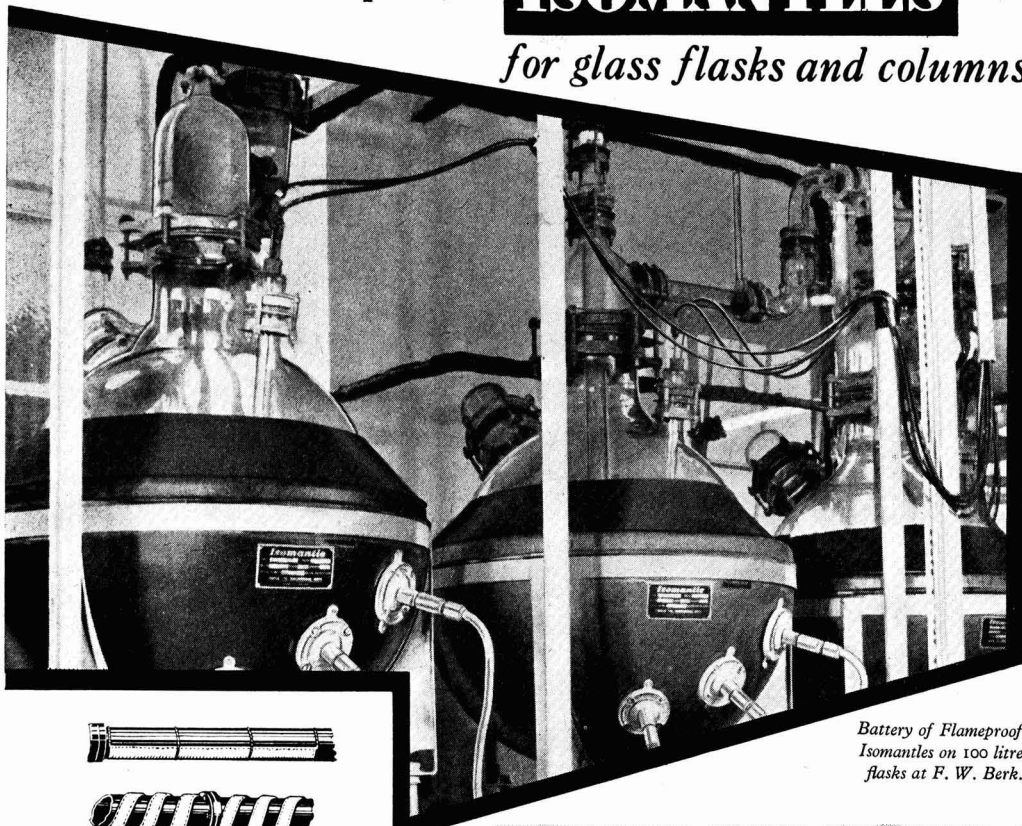

*flameproof***ISOMANTLES***for glass flasks and columns*

*Battery of Flameproof  
Isomantles on 100 litre  
flasks at F. W. Berk.*



*Special Flameproof  
Isotapes*

*For all  
Laboratory  
Flasks*



*Energy Regulator  
in Flameproof  
housing*

Apart from standard Isomantles, a full range of special equipment is available suitable for Flameproof areas groups I, II, III (Patent Number 713768) and accepted by the Authorities. This covers all flask sizes, cylindrical, reaction vessels with hemispherical bases and columns. Metal sheathed mineral insulated heating elements lead into Flameproof glands and terminal boxes. The element temperature is of course, kept below the ignition point of gas mixtures present; manual regulators in Buxton certified enclosures or automatic intrinsically safe controls are provided.

*Fully described in catalogue LM (Glass Plant)  
and catalogue PLT (Metal Vessels)—do ask for  
copies.*

**ISOPAD****ELECTRIC  
SURFACE  
HEATERS****ISOPAD LTD****Barnet By-Pass, Boreham Wood, Herts.***Phone: ELStree 2817/9.*



# Development chemicals from Heavy Organic Chemicals Division

NUMBER ONE

NAME	DESCRIPTION	QUANTITIES AVAILABLE	NAME	DESCRIPTION	QUANTITIES AVAILABLE
<b>Propylene Derivatives</b>			<b>Butylated Phenols</b>		
1	Propylene dichloride (1,2-Dichloropropane) Liquid. B.Pt. 96.3°C.	Tonnage quantities	8	3-Methyl-4:6 ditertiary butylphenol (3M46B) Solid. M.Pt. 56-58°C.	Technical grade. Tonnage quantities
2	Dichlorodisopropyl ether Liquid. B.Pt. 187°C.	45 gallon drum lots	9	3-Methyl-6-tertiary butylphenol (3M6B) Solid. M.Pt. 21-22°C.	Have wide applications in the rubber and plastics fields as well as other specified uses.
3	Dipropylene glycol Liquid. B.Pt. 232°C.	45 gallon drum lots			
4	Mixture of dipropylene glycol and higher propylene glycols (not refined)	Tonnage quantities	10	4-Methyl-2-tertiary butylphenol (4M2B) Solid. M.Pt. 50-51°C.	Refined grade. Tonnage quantities
<b>Phenols and Related Products</b>			3M6B and 4M2B have antioxidant properties themselves or can be intermediates for antioxidants in the rubber, plastics and petroleum fields. They are useful raw materials for resins, oil additives and rubber chemicals. In addition 3M6B and certain derivatives can be used as disinfectants, and it is also an intermediate for musk ambrette. 3M46B is of particular interest as an intermediate for reclaiming agents for rubber. It may be of interest in resins, plasticisers and surface-active agents.		
5	Cumylphenol (p-( $\alpha$ : $\alpha$ -dimethylbenzyl) phenol) Solid. M.Pt. 72-73°C.	1 lb. samples	11	2:4-Ditertiary butylphenol (2:4B) Solid. M.Pt. 53-54°C.	Of interest as an intermediate for surface-active agents and oil additives. Effective as a stabiliser for ethylcellulose.
6	Dodecylphenol (a mixture of isomeric p-dodecylphenols) Viscous liquid. 5%-95% boils at 320-335°C. at atmos. press.	1 lb. samples	1 lb. samples. Enquiries welcome for tonnage quantities		
7	2:5 Xylenol 80/90% 25.M content. Solid. M.Pt. 60-70°C.	Tonnage quantities	<b>Organic Acids and Anhydrides</b>		
			12	Isophthalic acid	Superior alkyd resins may be derived from isophthalic acid; it is important for high quality speciality polyester resins—and is also of interest for plasticisers.
			13	Trimellitic anhydride	Intermediate for oil-soluble and water-soluble alkyd resins. The trifunctional structure gives high reactivity and it is a useful start-point for the production of unsaturated polyesters, plasticisers, and epoxide resins.

IMPERIAL CHEMICAL INDUSTRIES LIMITED LONDON S.W.1.

Please send more information on these chemicals:  1  2  3  4  5  6  7  8  9  10  11  12  13

NAME: \_\_\_\_\_

TITLE: \_\_\_\_\_

COMPANY: \_\_\_\_\_

ADDRESS: \_\_\_\_\_

TEL. No.: \_\_\_\_\_

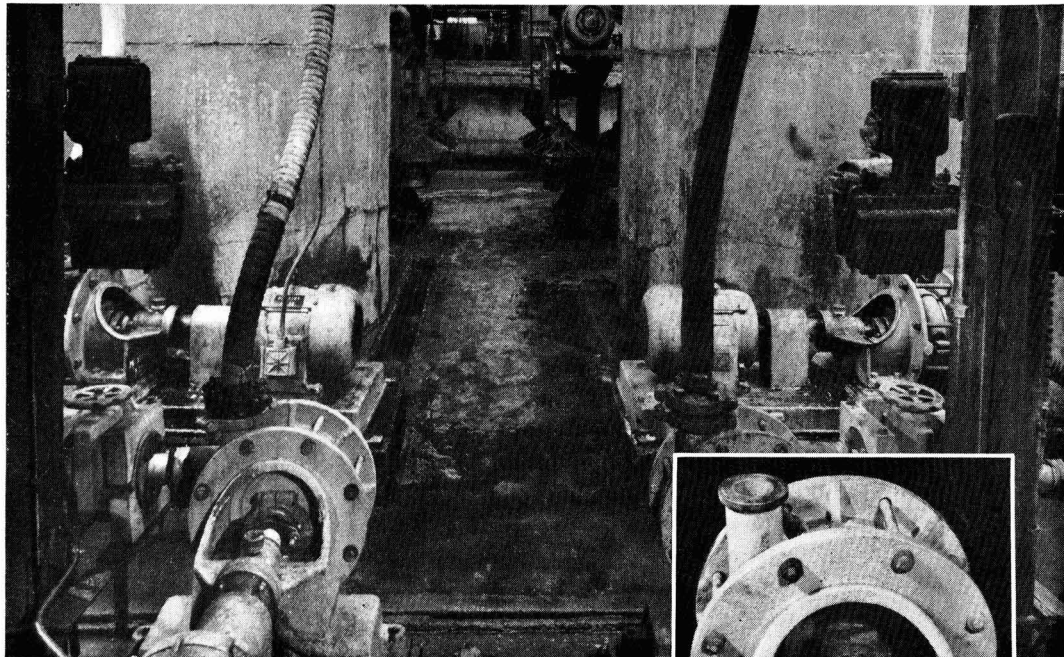

**'FLUON'** INCREASES PRODUCTION EFFICIENCY IN INDUSTRY

## 'Fluon' cuts maintenance costs, increases efficiency for Johnson, Matthey and Company Limited

Preformed packing rings made from plaited asbestos rope impregnated with 'Fluon' p.t.f.e. by Crane Packing Limited, are used for gland packings in the centrifugal pumps at Johnson, Matthey and Company Limited. These pumps handle highly corrosive nickel sulphate solutions, containing abrasive materials, up to temperatures of 70° C. These solutions attack all hydrocarbon lubricants, causing conventional gland packing rings to harden.

Johnson, Matthey and Company Limited had to adjust the former gland packing daily and replace packing rings every 200 pump-working hours.

Since changing to asbestos 'Fluon' packing rings there has been a remarkable improvement. At first, gland adjustments were made every two or three days. After a few weeks no attention was needed at all. The rings were found to be in perfect condition

after 7,000 hours' pumping the abrasive-free nickel sulphate solution. When the solution contained abrasives, the life of the rings was slightly shorter, but many times longer than that of any other packing.

Trials were run over two six-month periods and these results were obtained:

- (1) 67 conventional packing rings were replaced, over six months, in five 2" pumps. In the next six months, only 4 asbestos 'Fluon' rings were replaced.
- (2) 168 conventional packings were replaced, again over six months, in five 2½" pumps. In the following six months, only 31 asbestos 'Fluon' ones were replaced.

Initially, these new rings cost more. The extra cost is offset many times over in reduced maintenance costs and greater running efficiency of the pumps.

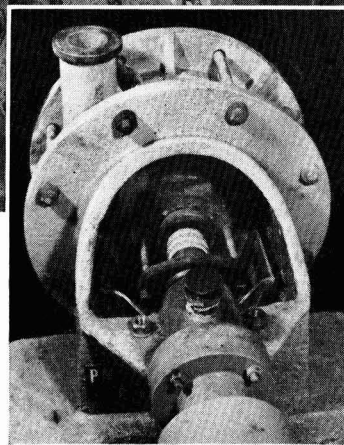

Pumps which handle highly corrosive nickel sulphate solutions, containing abrasive materials, up to temperatures of 70° C., at Johnson, Matthey and Company Limited, Brimsdown, Middlesex, showing asbestos 'Fluon' gland packings made by Crane Packing Ltd., Slough. The inset shows a close-up of the packing rings in one of the centrifugal pumps.

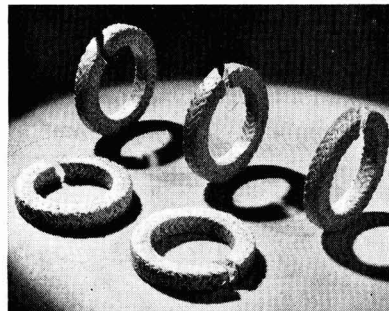

Plaited asbestos rope impregnated with 'Fluon' p.t.f.e. and made into preformed gland packings by Crane Packing Ltd., Slough.

**'FLUON'**

'Fluon' is the registered trademark for the polytetrafluoroethylene manufactured by I.C.I.

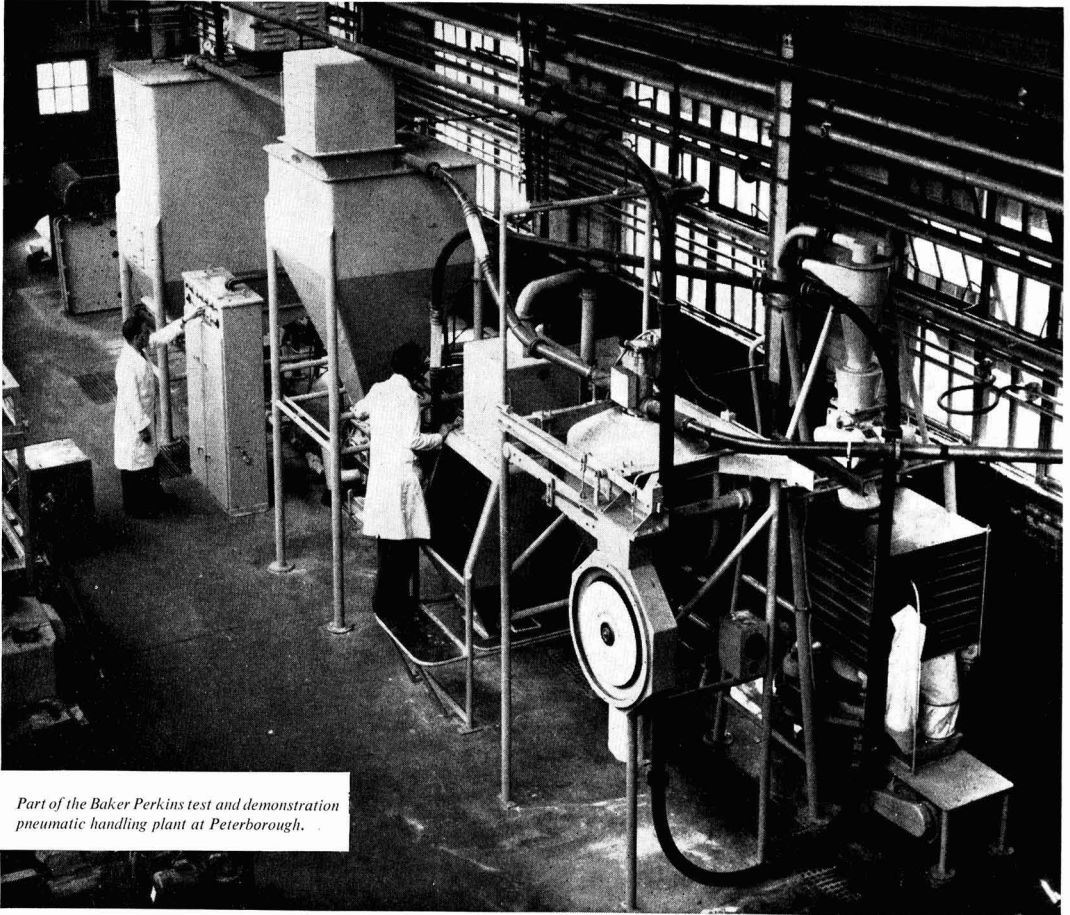
**Baker Perkins****PNEUMATIC HANDLING**

*Part of the Baker Perkins test and demonstration pneumatic handling plant at Peterborough.*

**CONSULTATION**

Baker Perkins have a pilot pneumatic handling plant for carrying out tests on customers' materials. The Consultation Service includes both advice and visits by our engineers.

Baker Perkins bring a special kind of experience to pneumatic handling problems. The Baker Perkins Group, which serves the food, chemical, paint, plastics and foundry industries, has exceptional knowledge of handling and processing a wide variety of materials.

This experience is at your service. We invite you to make use of it.

***Baker Perkins Ltd.***

*Westwood Works · Peterborough Tel: Peterborough 67411*



# British Celanese

Limited

**expanding in chemicals**

**the many  
'Celanese' chemicals  
and allied products  
include**

**orders large or small**

Celanese resources are geared to bulk shipments, but small orders receive equally prompt and careful attention

Write for information and samples to:—  
Chemical Sales Department  
BRITISH CELANESE LIMITED  
Foleshill Road, Coventry  
Telephone : 88771

welcome enquiries for new products, particularly in the petrochemical and cellulose derivative fields

Acetamide (Technical)

Acetyl acetone

Cellulose acetate flake

Diethyl sulphate

Diketene

N-Methyl acetamide

Methyl cellulose ('Celacol')

Peracetic acid

Sodium carboxymethyl cellulose ('Courlose')

Trichlorethyl phosphate (T.C.E.P.)

Vinyl acetate monomer

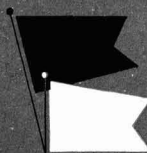

*'Celanese' chemicals*

## **DUNLOP HAS THE ANSWER**

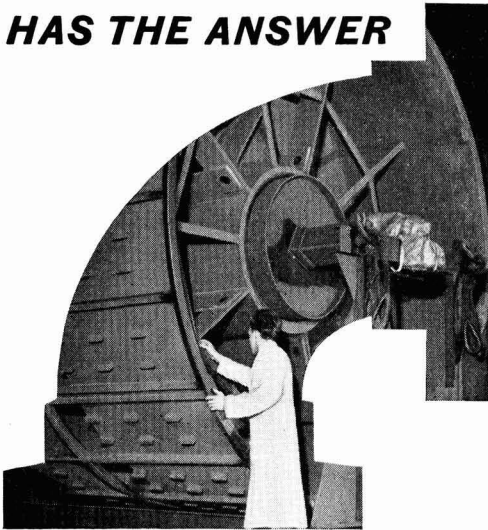

### Anti-corrosive linings

The DUNCLAD plant lining service prevents waste and cuts costs by protecting industrial plant and equipment against corrosion. Backed by field experience unequalled anywhere in the world, and based upon extensive research and manufacturing facilities, DUNCLAD supplies and installs heavy-duty rubber and allied linings—butyl, P.V.C. and neoprene—which prolong the life of tanks, pipes, fuel chutes and brickwork for many years to your benefit.

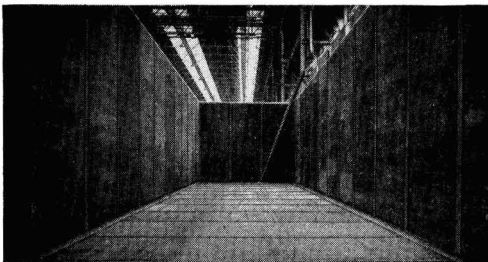

**DUNCLAD**  
PLANT LININGS BY

# **DUNLOP**

Dunlop Rubber Co. Ltd., G.R.G. Division,  
Cambridge Street, Manchester Telephone: Central 2131

## For **STEEL DRUMS**

MILD STEEL  
LACQUER LINED  
TINNED  
GALVANIZED  
STAINLESS STEEL  
ETC.

*IMMEDIATE DELIVERY  
KEENEST PRICES*

**NEW or RECONDITIONED**

★

### **STEEL DRUMS LTD.**

Fresh Wharf Estate,  
**HIGHBRIDGE RD., BARKING, ESSEX**  
RIPpleway 4373/4/5

The **Jefco**



**FACE SCREEN**

Reg. Design 751914 Patent applied for

Perfect protection when grinding or machining. Comfortable to wear, stands clear of the face, adjustable to any angle, non-splinter front easily renewable.

**J. & E. FERRIS LTD**

33 Museum St., London, W.C.1  
Telephone: MUSEum 2876

# SULPHUR from LACQ

K. W. Chemicals Limited  
have been granted  
by Societe Nationale  
Des Petroles D'aquitaine  
exclusive concessions  
in the United Kingdom  
as stockists and grinders  
of Lacq Sulphur

K. W. Chemicals Limited  
have further concluded  
partnership agreements  
for these concessions with  
William Blythe & Co. Ltd.  
of Accrington

ENQUIRIES FOR BRIGHT SULPHUR  
AND GROUND SULPHUR  
SHOULD BE ADDRESSED

*Either to:*

K. W. CHEMICALS LIMITED  
CAROLINE HOUSE,  
55/57 HIGH HOLBORN,  
LONDON, W.C.1.  
Tel: CHAncery 7981/7

*or to:*

WILLIAM BLYTHE & CO. LTD.  
HOLLAND BANK WORKS,  
CHURCH, ACCRINGTON,  
LANCASHIRE.  
Tel: ACCrington 32141





TRANSMISSION

CONTROL

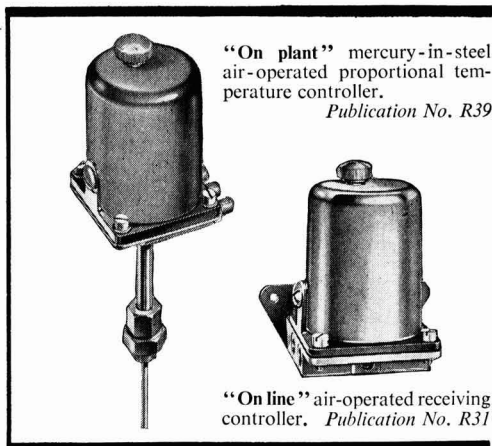

"On plant" mercury-in-steel  
air-operated proportional tem-  
perature controller.

*Publication No. R39*

"On line" air-operated receiving  
controller. *Publication No. R31*

Mercury-in-steel air-operated temperature transmitter  
with Polyester resin glass-fibre cover, stainless steel base, stem and  
bulb. *Publication No. T39.*

High thermal response. Wide range of temperatures.  
Standard output air pressure, 3-15 p.s.i. Small and compact.

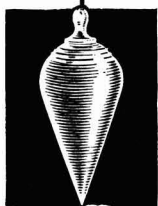

# **NEGRETTI & ZAMBRA**

*The name that means precision all over the world*

NEGRETTI & ZAMBRA LIMITED  
122 Regent Street, London W.1

VOL. 84

No. 2149

SEPTEMBER 17 1960

Telephone: FLEet Street 3212 (26 lines)

Telegrams: Benformula - Cent - London

Editor

M. C. HYDE

Manager

R. C. BENNETT

Director N. B. LIVINGSTONE WALLACE

**Midland Office**Daimler House, Paradise Street,  
Birmingham. [Midland 0784-5]**Leeds Office**Permanent House, The Headrow  
Leeds 1. [Leeds 22601]**Scottish Office**116 Hope Street, Glasgow C2.  
Central 3954-5]**IN THIS ISSUE**

Coal for Chemicals	420
C.B.M.P.E. Mission to S. America	420
Project News	421
Learning Scientific Russian	422
Chemical Plant Deliveries	423
Distillates	424
Chemicals at Farnborough	425
Interfirm Comparisons	426
R.I.C. Membership Proposals	427
Multiwall Sack Code Sought	428
D.S.I.R. Fire Research	428
Polymer Paper at B.A. Meeting	429
Pure Food Centenary	430
Shell at Macroplastics Show	430
Overseas News	431
People in the News	432
Trade Notes	433
Commercial News	434
New Patents	436
Market Reports	438
Diary Dates	438

Annual subscription is: home, 52s 6d,  
overseas, 60s, single copies 1s 6d (by  
post 1s 9d)

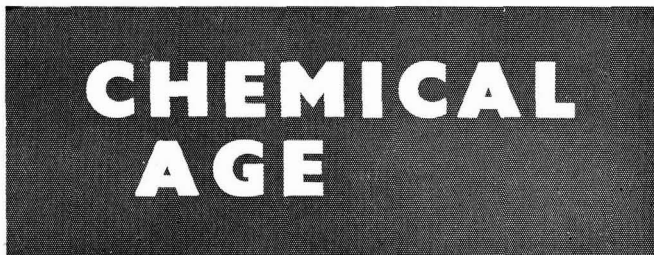

BOUVERIE HOUSE · 154 FLEET STREET · LONDON · EC4

**SYNTHETIC RUBBER TRENDS**

**I**N the past few months, the U.K. synthetic rubber picture has changed dramatically. In the spring, British capacity stood at just under 90,000 tons, with the International Synthetic Rubber Co. at Fawley accounting for 77,000 tons/year of S.B.R. Remainder of the output went on specialty rubbers with I.C.I. producing some 7,000 tons/year, 2,000 tons/year from Dunlop, with Monsanto Chemicals Tred styrene/butadiene copolymer plant at Newport, British Geon's Hycar nitrile rubber unit in South Wales.

Since then Du Pont have come on stream at Maydown, Northern Ireland with their 22,300 tons/year neoprene plant, which is to be increased to 25,000 tons/year. I.S.R. by the end of this year will have raised their production to 90,000 tons/year and Esso Petroleum Co., who have been planning a U.K. butyl plant for some time recently announced plans for a 30,000 tons/year plant at Fawley.

I.S.R. also this year brought on stream a plant producing high-solids S.B.R. latex at Hythe. Currently this unit has a 3,500 tons/year capacity, but output may be doubled by the end of 1960. Now Witco Chemical Co. and United States Rubber Co. have set up Sto-Chem Ltd., a joint subsidiary to produce some 3,500 tons/year of S.B.R., high styrene, nitrile and acrylic types of synthetic latex at a plant to be built in the Midlands. This is due in production by the autumn of 1961.

A further development in the U.K. synthetic rubber field is the planned entry of Shell Chemical with a "substantial capacity" for polydiene rubbers. At the time the announcement was made Shell Nederland N.V. stated they would build a parallel plant in Holland. Capacity of the Netherlands unit has since been given at 25,000 tons/year of polyisoprene.

Since Shell Chemical Company Division of Shell Oil Co., in the U.S., decided early in 1959 to set up a 15,000 to 20,000 tons/year polyisoprene plant, it seems likely that the U.K. plant will also produce polyisoprene.

On completion of all these projects, U.K. production of synthetic rubbers will approach 200,000 tons/year—a big increase on the mid-1960 figure of 90,000 tons. While the British industry has been slower off the mark to develop synthetic rubber facilities, the planned increases already disclosed will make the U.K. one of the world's major producers. At present, West Germany has a 130,000 tons/year capacity, with 120,000 tons from Bunawerke Hüls. Farbenfabriken Bayer propose to raise their production of special rubbers from a current figure of 10,000 tons to 40,000 tons.

France now produces 20,000 tons of butyl in the Esso plant near Le Havre, while a consortium plans to produce 50,000 tons of cold rubber by 1961 at Berre, with the aim of raising capacity eventually to 70,000 tons/year. Ugine, with United States Rubber, plan to erect a 10,000 tons/year plant at the foot of the Montblanc range, giving France a capacity of 110,000 tons/year of synthetic rubber.

Elsewhere in Europe, Shell earlier this year commissioned their 50,000 tons/year plant at Pernis, while ANIC of Italy, have a 70,000 tons/year plant at Ravenna.

In the U.S. synthetic rubber production is estimated at 1.8 million tons/year. Newly announced plans include those of Phillips Chemical to raise

their *cis*-4-polybutadiene output from 20,000 to 25,000 tons/year and those of American Rubber and Chemical (a joint Stauffer Chemical and American Synthetic Rubber venture) to produce 30,000 tons/year of polybutadiene and polyisoprene; this capacity could be raised to 50,000 tons/year.

World total capacity, including that of Soviet Union (estimated 500,000 tons/year) and the Communist bloc is estimated at 3 million tons a year; if all the synthetic rubber plants (some projects must be placed in the 'pipe-dream' category), came to fruition, world capacity would be raised to 5.6 million tons. A figure of between 4 and 5 million tons is likely to prove nearer the mark.

In any event, free-world consumption of rubber, at present totalling about 3.9 million tons a year—about 1.8 million tons of which is in synthetic rubber—is steadily increasing. Little likelihood is seen of over-capacity in synthetic rubbers, in fact it is hoped that production of natural rubber can be raised from the current figure of 2 million tons/year to something like the maximum of 2.4 million tons, in order to meet all demands. The two products—man-made and tree rubber—are likely to remain complementary, rather than competitive.

## CHEMICALS FROM COAL AGAIN

A FEW years ago, when the fuel situation in the U.K. was very different from what it is now, and before the petroleum refining and petrochemical industries became firmly established, there was a good deal of discussion about the possibilities of using coal as a direct source of oil and chemicals, e.g. by such processes as hydrogenation or Fischer-Tropsch synthesis. Enthusiasm now seems to be waning, partly because of the changed energy situation but chiefly because of the technical problems encountered in developing these processes to a point where they can be operated economically on the large scale. The report of the Ministry of Power Committee on Coal Derivatives (the Wilson Committee), summarised in our issue of 20 August, seems to be fairly emphatic about the limitations of such processes for commercial development at present.

Further light on the subject of coal chemicals comes from some comments made by Dr. D. T. A. Townend, director-general of the British Coal Utilisation Research Association, at a study conference on the future of the coal industry, organised by the National Union of Mine-workers in London recently. One particularly illuminating observation is that only 1% of the 50 million tons of coal carbonised in this country finds its way as by-product chemicals. New possibilities may always arise, but from our understanding of the chemical configuration of the coal substance, upon which future progress depends, the scope at present seems to be limited except in so far as changes in the traditional systems of carbonising coal become possible; for the economic production of chemicals seems to hinge on their being by-products of a major process.

In his address, Dr. Townend explained the chemical structure of coal and showed that the current percentage yields of by-products obtained during carbonisation were very low as compared with those potentially inherent in the model structure as now envisaged. There appears to be scope for experimental investigation in order to increase the yields of those by-products of carbonisation for which there is a considerable market. Unfortunately, however, our present knowledge casts doubt on the possibility of securing economically these or other chemicals from coal by more direct methods (i.e. other than as by-products).

As far as oil is concerned, coal can of course be con-

verted to oil by direct addition of hydrogen, a process formerly operated by I.C.I. at Billingham; but the hydrogen necessary is expensive, and still more coal is required to provide the energy necessary to operate the plant, and finally the cost of the plant itself is high. Dr. Townend also dwelt briefly on the Fischer-Tropsch method but pointed out that the hydrogen and carbon monoxide for this process still have to be derived at moderately high cost.

Amongst contributors to the discussion at the conference was Dr. W. Idris Jones, N.C.B. director-general of research, who thought that, although getting oil from coal was, on present costs, uneconomic, there was much to be done on the direct use of coal as a chemical. Our most lucrative chemicals from coal from the commercial standpoint were products like benzene and naphthalene. For these there was a prodigious growth in demand by the chemical industry. This was a challenge to the coal industry to enhance the yield of benzene and naphthalene, phenol, carbolic acid, creosote and so forth, for their further use by the British chemical manufacturers.

## IMPORTANCE OF CREDIT

REPORT on the exploratory mission to the Argentine and Chile of the Council of British Manufacturers of Petroleum Equipment, 2 Princes Row, Buckingham Palace Road, London S.W.1 (price 12s 6d), makes depressing reading. Not because the opportunities for trade in oil equipment and chemical plant do not exist, but because in both countries the key to trade is 'credit' and the main potential customers require credit terms which cannot, at present, be met by the British authorities under the existing credit insurance conditions.

In the Argentine the bids likely to be successful will offer credit terms which demand no down payment and no payment for one or two years. Subject to delivery and technical specification meeting requirements and the price being competitive, it is the best financing offer which will tip the scale. Interest rates vary from 6 to 9%. In Chile, potential buyers are likely to seek a sliding scale of payment terms depending on the volume of purchases, e.g. eight years for purchases exceeding £x million in an agreed period, with a decreasing number of years for smaller amounts in proportion to the reduced volume of purchases.

Several capital projects are being planned in the Argentine including a lube-oil plant. The mission says that in petrochemicals there is an enormous potential yet to be planned and developed, but on a 'Private enterprise' basis.

Of course, many industrialists in the U.K. feel that political and commercial risks in South America are too great and they would like to wait until conditions improve. By that time, as the mission points out, the opportunities for trade might be irretrievably lost, particularly in view of the possible strong demand for heavy capital equipment in Latin America over the next 10 years or so.

The U.K. will only regain its position in the Argentine through an immediate reappraisal and improvement in the financial conditions available. The mission urges that every means should be sought to bring about a change of attitude and action towards Argentina which would demonstrate Britain's confidence in the future development of that great country.

Certainly a change of heart should not be delayed by the Government, the Foreign Office, the Treasury, Board of Trade, the banks and those other City institutions that influence Britain's overseas trade.



## Project News

# New Witco—U.S. Rubber Firm Plans Latex Plant in Midlands

**PLANS** to form a new chemical company, Sto-Chem Ltd., to produce synthetic rubber latices in the U.K. have been revealed by Witco Chemical Co. Inc. and the United States Rubber Co. Negotiations are in progress for the acquisition of a 20-acre site in the Midlands where a new plant will be built. Total investment will be around £1 million.

First news of this project appeared in *CHEMICAL AGE*, 2 April, p. 563, but the participation of the U.S. Rubber Co. had not then been revealed. It is now confirmed that the plant will have an initial capacity of 8 million lb. and will produce a complete line of butadiene-styrene, high styrene, nitrile and acrylic types of synthetic rubber latex.

Four contracting firms, whose names are not revealed, have been sent 'invitations to bid'. It is planned to commence engineering work in four or five weeks' time, while site construction work should begin early next year. Sto-Chem expect to have the plant in operation by the autumn of 1961. Distribution of Sto-Chem's output will be handled exclusively by Witco Chemical Co. Ltd., London, a wholly owned subsidiary of the U.S. firm. (See 'People', p. 433, for news of Sto-Chem executive appointments.)

### Naugatuck Licence

Technical assistance for the design and construction of the Sto-Chem plant will be provided by U.S. Rubber's Naugatuck Chemical Division. When the plant goes on stream, it will produce formulations under a licence granted by Naugatuck Chemical, and the division will also aid in technical service work. Naugatuck Chemical have been a major force in the latex industry since the early 1930's, and their research staff was among the pioneers in the field of synthetic latices.

Witco Chemical Co. Ltd. are among leading U.K. custom compounders of synthetic and natural latices, and have production facilities and laboratories at Droitwich, Worcs. They have sales offices in London, Manchester and Glasgow, while European sales outlets include branch offices in Rotterdam, the Netherlands, and a wholly-owned subsidiary in France.

The news of the Sto-Chem venture follows close upon International Synthetic Rubber Co.'s revelations about its new plant at Hythe for producing high solids S.B.R. latex, discussed in last week's issue, p. 383. It is interesting to note that the Hythe plant is at present producing some 3,500 tons/year of high solids S.B.R. latex, which is about the same as the 8 million lb./year of latex of all types to be produced in the Sto-Chem plant.

Crawford and Russell Inc., Stamford, Conn., engineering and construction firm, have now completed the design of a \$2.5 million latex plant to be built by Sto-Chem Ltd., of Stoke Prior, Worcester.

The Crawford and Russell work was

### C.A. Survey of New Chemical Projects

Next week's issue of 'Chemical Age' will include an 8 page survey of new U.K. chemical projects. It will collate in one feature all the major expansion projects announced this year as well as innumerable less spectacular, but nonetheless important schemes that are either in hand or which were completed during the year.

In addition this issue will feature the activities of some of the leading contracting organisations in this country and abroad together with a review of new items in the plant and equipment field

carried out in close co-operation with the engineering staff of the Naugatuck Chemical Division of U.S. Rubber.

The Stamford firm has developed a new process for producing stereospecific rubbers in continuous sheet.

## Second Major Expansion to Courtelles Acrylic Fibre Capacity at Grimsby

● SECOND 10 million lb./year expansion to their Grimsby plant for the production of the acrylic fibre, Courtelles, is planned by Courtaulds Ltd, to raise capacity at Grimsby to 30 million lb./year. Courtaulds also have a 2 million lb./year capacity at Coventry, where their first commercial plant for Courtelles began production in 1957.

First 10 million lb. expansion project at Grimsby, announced last year, is due to start production shortly. Preparatory work on the latest development scheme is already at an advanced stage.

The company's Courtelles plant at Calais, under the direction of Courtaulds France, S.A., a subsidiary in whom the Provoust Group of Roubaix are participating, was announced in October 1959. The new plant is in an advanced stage of construction and it is now revealed that production will be 10 million lb./year. The unit is due to start operating next year.

In addition, Courtaulds are supplying complete plants to the Soviet Union and Yugoslavia for the production of acrylic fibres by the Courtelles process.

### B.B.H. Maleic and Phthalic Plants On Stream Soon

● Now erecting a plant at Belvedere, Kent, for the production of maleic anhydride are Alchemy Ltd., a wholly-owned subsidiary of Burt, Boulton and Haywood Ltd. Production of this chemical, world consumption of which is rising steadily, is scheduled to start at about the end of 1960. The new phthalic anhydride unit of South Western Tar Distilleries Ltd., a Burt, Boulton and Haywood associated company, is now making preliminary runs at Totton Works, Southampton.

## Two Big Coke-oven and By-products Contracts

● ORDERS totalling over £4 million for two new coking and by-products installations, have been received by Woodall-Duckham Construction Co. Ltd., the contractors, for Colvilles Ltd., United Coke and Chemicals Co., a subsidiary of the United Steel Companies.

Colvilles have ordered two further batteries of coke ovens with complete coal and coke handling systems and a by-products recovery plant for their Ravenscraig works. This new plant will have a coke output capacity equal to that

of the plant at present under construction so that, by the end of 1962 when all six batteries will be in operation, the Ravenscraig works will be processing 1,750,000 tons of coal annually.

The United Coke and Chemicals contract includes the demolition of a derelict battery of ovens with by-products recovery and benzole plant, and the building of a new battery of 43 ovens. Demolition is already in progress and the building of the new ovens should be completed by the end of 1962.

## Shell and Montecatini to make Polypropylene in the Netherlands

● AGREEMENT on the formation of joint company in the Netherlands, which will build a new polypropylene plant, has been reached between Bataafse Petroleum Maatschappij N.V. (Royal Dutch/Shell)

and Montecatini (Societa Generale per l'Industria Mineraria e Chimica) of Milan. According to a statement issued by Shell in London the purpose of the new company will be "to build and

operate at Rotterdam, in conjunction with the works of Shell Nederland Raffinaderij N.V., a factory destined to manufacture, in the first phase, and on a large scale, polypropylene for plastics.

The new company is to be called N.V. Rotterdamse Polyolefinen Maatschappij. Royal Dutch/Shell and Montecatini capital participation in R.P.M. will be in the ratio 60:40. For the time being, sales of the product from the R.P.M. plant will be restricted to the Benelux area. Sales in this area will be handled by the companies of the Royal Dutch/Shell

Group through its existing organisation.

Shell Chemical Co. (U.K.) are currently constructing a 30,000 tons/year plant for the production of polypropylene and other polyolefins at Carrington, near Manchester, under a licence obtained from Montecatini in 1959. I.C.I., also with a Montecatini licence, are constructing a 10,000 tons/year polypropylene plant at Wilton. I.C.I. recently obtained an exclusive Montecatini licence to produce polypropylene fibres filament yarns and textile monofilaments in the U.K.

## Contracts Awarded by A.E.A. for New Research Reactor at Winfrith

**C**ONSTRUCTION contract with Fairey Engineering Ltd., and a control gear design contract with H. M. Hobson Ltd., have been signed by U.K.A.E.A., in connection with a new zero-energy oscillator reactor which is to be built at the Atomic Energy Establishment, Winfrith. The reactor, which will be called HECTOR (Heated Experimental Carbon Thermal Oscillator Reactor), has been designed expressly to facilitate the use of the pile oscillator technique for evaluating the nuclear behaviour of fuels, moderators, and structural materials in reactors. This technique, which utilises small samples, has been highly developed by the A.E.A. to further the reactor physics aspects of power reactor development. HECTOR is expected to go critical during 1962.

HECTOR possesses a unique feature in that it is possible to reproduce closely the conditions appropriate to many different designs of power reactors. It is believed to be the world's first reactor in which oscillator measurements can be made in such a wide range of conditions.

The reactor core is an annulus of graphite and highly enriched uranium/aluminium alloy within which various assemblies of fuel and moderator may be constructed around a central tube. The sample under investigation will be cycled through this tube, producing oscillations in reactor power level from which the nuclear behaviour of the sample, under the conditions reproduced by the assembly can be determined. Since the fuel material in the assembly may be natural or enriched uranium 235, plutonium, thorium, uranium 233 or irradiated elements from power stations, and since the assembly can be heated to 450°C, it is possible to investigate samples under the conditions to be found throughout the life of many different designs of power reactors.

### Esso's Fawley Additives Plant Due On Stream Soon

● The new lube-oil additives plant of Esso Petroleum Co. Ltd. at Fawley, designed to raise capacity by 2½ times to nearly 11,000 tons/year, is scheduled on stream by early December. Main contractors are Foster Wheeler Ltd. The unit will replace the smaller plant and will supply additives to Esso associated

companies in Europe, except France.

Three additives to be made are: Paradox 351, a detergent inhibitor; Vistone GB, an 'oiliness additive' for industrial and thin oils; and Edco 197, a multi-purpose additive which is mainly a viscosity index improver dispersant, but which incorporates a pour-point depressant.

### Tidewater Plan Petrochemical Facilities in Denmark

● POSSIBILITIES of setting up petrochemical operations adjacent to the new refinery which is being built at Kalundborg, Denmark, are the subject of talks between Tidewater Oil Co. (U.S.)—whose Danish subsidiary will operate the refinery—and two other companies, one of these being a small West German concern. Tidewater Oil and their subsidiary, Dansk Veedol Aktieselskab, are concerned only with oil refining, so that other companies will participate.

So far, plans have been made for the use of Kalundborg refinery by-products in the manufacture of fertilisers by Dansk Svovlsyre and Norsk Hydro, who are, respectively, Denmark's and Norway's biggest fertiliser producers.

As reported in CHEMICAL AGE, 2 April, p. 563, the new refinery will be partly constructed by Foster Wheeler, London.

### Foster Wheeler Get Montreal Aromatics Contract

● A CONTRACT for the construction of a \$2.5 million extraction plant for aromatics at the Montreal East refinery of British American Oil, has been awarded to Foster Wheeler Ltd. A main product of the new plant will be benzene for British American's cumene facilities. Cumene is converted to phenol and acetone at the nearby plant of B.A.-Shawinigan.

### Y.P.F. Buy in Germany

● THE German firm Maschinenfabrik Augsburg-Nürnberg AG. (M.A.N.) has secured an order for 12 spherical gas holders for the storage of propane and butane. The purchaser is the Yacimientos Petroliferos Fiscales, Buenos Aires, a government-controlled enterprise in the Argentinian petroleum industry. The contract value is about DM9.4 million.

### Learn Scientific Russian the Easy Way with C.A.

**N**EXT week 'Chemical Age' begins an important venture to all chemists wishing to keep themselves informed of developments in the Soviet chemical field. The first of its kind in British chemical journalism, it is the serialisation of Professor J. W. Perry's book 'Scientific Russian Without Tears.'

First published in the U.S. under the imprint of the American Chemical Society, study of this book has already enabled many hundreds of chemists and non-technical executives to master the complexities of scientific Russian and to follow first-hand the important advances now being made in the Soviet chemical industry and in the many State research institutes.

By following Professor Perry's 'Scientific Russian Without Tears' in CHEMICAL AGE readers will soon find they are well able to keep abreast of Soviet work without having to wait for translations. Readers who would like to receive extra copies of CHEMICAL AGE to avoid cutting existing copies, should complete the subscription order form in page 443 and return it as soon as possible to the Manager, CHEMICAL AGE, 154 Fleet Street, London E.C.4.

### S.C.I. Polymer Meeting in London

SYMPOSIUM of the Plastics and Polymers Group, Society of Chemical Industry, on 'High-temperature resistance and thermal degradation of polymers,' will open at William Beveridge Hall, London University, at 9.45 a.m. on 21 September under the chairmanship of Professor H. J. Emeleus, C.B.E., F.R.S. Mr. P. S. Adamson, director of B.X. Plastics Ltd., and chairman of the group, will give an introduction and there will be an opening address by Sir Owen Wansborough-Jones, K.B.E., C.B., technical director of Albright and Wilson Ltd.

The symposium dinner will be held at the Londoner Hotel, Welbeck Street, London W.1, on 22 September at 7 p.m. The full list of papers was published in CHEMICAL AGE, 28 May, p. 879.

### Bradford Establish Department of Chemical Engineering

The governing body of the Bradford Institute of Technology has decided to establish a Department of Chemical Engineering to take the place of the existing chemical engineering section of the Department of Chemical Technology. The principal lecturer is to be Mr. C. W. Page.

### York Refrigeration Plant for Bush Crystal

A method developed by Brush Crystal Co. Ltd. for growing high quality crystals under rigidly controlled conditions requires extensive refrigeration and heating plant. A second plant for this purpose has recently been completed and installed by York Shipley Ltd. The first plant was installed in 1953.

# WARNING ON COMING DELIVERY DELAYS

## *Sparte of New Plant Projects will Extend Equipment Makers' Facilities*

**D**ELIVERIES—what a change in the situation! During 1958-59, when the chemical plant industry was in the 'doldrums,' every buyer was besieged by technical sales representatives, cards were sent up by commissionaires, from firms which the recipient had never heard of, phrases such as "You want it in six weeks—we'll do it in five" were heard. Prices were keen, profit margins were slashed, keeping production capacity filled was the main object of operations. Make no mistake—it was not a slump, there was work about, but it had to be fought for, and it went to those who gave the best service. To a generation of salesmen who had never had to sell (or who had forgotten how to), this was a new experience. Anxious sales managers spurred their sales forces to greater efforts. Most people admitted to "Just about equalling last year's figures."

Then, with the election, a dramatic turn of events came about. People rang up: "You know that scheme we were talking about last year—we want to go ahead with it." Project after project was announced. Stainless steel first, then electric motors, gearboxes, bearings, oil seals, the basic bricks of the chemical plant industry are all now on extended delivery. Most firms have as large an order book as they have ever had. Since the beginning of 1960, delivery of 25 h.p. electric motors has extended from 12 weeks to 25 weeks, stainless steel from three months to six or nine months, gearboxes to six months, etc. In fact, stainless steel deliveries are now being extended at the rate of two weeks per month.

Why has this situation come about? Well, first of all, there are large amounts of chemical plant being sent abroad. Courtauld's obtained an £18 million order from the U.S.S.R. The C.B.P.M.E., together with Fluor and McKee Head Wrightson, are doing large quantities of work for Pemex in Mexico (although much of it is being purchased with Continental credits). These are large steel works with associated chemical plant being erected in India. The oil companies are building more and more refineries and many contracts have been awarded to British companies, or British subsidiaries of U.S. companies, to be more precise. Procon are building refineries at Tenerife, Lourenco Marques and in the Philippines. Foster Wheeler in Denmark for the Tidewater Oil Company, in Turkey for a consortium at Mersin, at Milford Haven for Esso, etc. Kellogg's at Karachi for Shell, at Izmit in Turkey for Caltex, Bechtel in the Philippines for Shell, and Panama for the Continental Oil Co. Fluor in South

America at El Salvador for Shell. The above are complete refineries.

At Grangemouth, Lummus are building an ethylene dichloride plant, Chemico a methanol plant and Fluor a butadiene plant. I.C.I. Severnside is now starting to be planned out and two con-

### By 'Contractus'

**Author of this article is actively employed in the chemical plant and equipment manufacturing industry and his reasons for using a 'nom-de-plume' will be obvious. He writes this report to warn the chemical plant industry of what he believes to be dangers inherent in present relations between suppliers and users of plant and equipment**

tracts have already been awarded. Shell and I.C.I. are both well ahead with construction of their polypropylene plants, contracts being carried out by Matthew Hall and C.J.B. respectively. Distillers are carrying out extensions to plants at Barry and Hull, contracts being, in this case, awarded to P.G. Engineering and the Lummus Co.; Laporte's have built a sodium chlorite plant and are building a ferric chloride plant, work being undertaken by their central engineering department. W. J. Fraser are carrying out extensions to Murgatroyds Salt and Chemical Co., Foster Wheeler are building extensions to Esso's Fawley ethylene unit and also building a lube oil additives plant on the same site.

The above list could be made much longer and only a few of the major contracts being carried out have been named, but it will be realised that the mounting of so many contracts in such a short time has thrown a great strain on the resources of the British chemical plant industry, and it must be further realised that many of these contracts are only in their early stages and are still only being planned out and engineered; very little purchasing has been finalised apart from some very major items of equipment.

The peak is yet to come, for many of these contracts will take anything up to three years to complete. In one year from now, equipment manufacturers will be selling on delivery, not on price. As yet, the effect of all the large contracts placed with the major contractors is only just beginning to be felt by the equipment manufacturers, and down the

line to the basic brick manufacturers (electric motors, etc.) mentioned previously. As the major contracts gather momentum, more and more demands will be made, and it behoves the British engineering industry to 'gird up its loins' and prepare for it.

How much preparation is being made? Very little. Whilst the order books are full, some firms are tending to treat their clients in the old off-hand manner; deliveries are not being adhered to, the standard excuses are being trotted out, and many of the contractors are looking farther afield for suppliers to the Continent; in particular Germany, Holland and Italy. This is a dangerous situation, as once contacts are built up, permanent loss of business can result, besides the obvious filip for competitors.

Do in fact the British chemical plant manufacturers realise what is going on? Are they making preparations, not to work just at full capacity but to increase their capacity for what is to come next year, and the year after? The author believes not.

The B.C.P.M.A. and the C.B.M.P.E. do good work with their foreign trade missions, their get-togethers and other activities, but are they alive to this situation, and if they are, what are they doing about it?

The present and future situation is not an academic one but a very real one, inasmuch as it concerns the future pattern of the British chemical plant industry and its survival, and more specifically the £ s d it will make in the future.

## Honeywell's Integrated Computer Control for Chemical Plants

CHEMICAL manufacture, petroleum refining and the pipeline transmission of natural gas are among applications of a new, completely integrated computer control system introduced by the American associates of Honeywell Control Ltd. It is claimed that the system makes it possible, for the first time, to obtain from one source a computer control system subject to a single responsibility for concept, equipment, installation, service, maintenance, and the training of personnel in its operation.

Basics of the system is the Honeywell 290 digital computer, a general purpose all-solid-state device specifically designed for process applications. The design incorporates high speed internal operation, magnetic core and auxiliary magnetic drum memory, random access of input and output channels, and a special instruction vocabulary.

First application of the integrated computer control system will be at Philadelphia Electric Co. where it will totally control a complex power network to give efficient use of generating facilities.





★ WHEN I heard that a Cardiff firm of civil engineering contractors had perfected a method of preventing pollution of beaches, I imagined at first that engineers, with their traditional scorn for chemistry, had decided to put a stop to all this nonsense about spraying chemicals on the sea and beaches to prevent oil pollution (see my comments in the 6 August issue, p. 196), and had stepped in at last to show that the solution of this problem was a perfectly simple engineering matter.

Enlightenment came with the explanation that the firm in question, Land and Marine Contractors, had developed a technique for laying pipe-lines along the sea bed to allow the safe disposal of wastes from industrial works. So it was pollution from trade wastes, not oil, that they were concerned with. The idea is interesting all the same, though, and I understand that a sub-marine pipe-line some 8,000 ft. long is now being constructed for Richard Thomas and Baldwins' new Spencer works at Newport, Mon, where it will act as an out-flow for combined sewage and trade waste. The same contractors have already finished, in South Wales, the laying of a sub-marine pipe-line a mile long and 18 in. in diameter for Monsanto.

★ AFTER all the upheaval that has been caused in the world's uranium industry because of curtailed demand and falling prices, it comes as something of an anti-climax to learn that New Zealand has no deposits of uranium that can be economically exploited at present, and that the U.K.A.E.A. has now withdrawn from a 'top-secret' agreement to investigate the deposits with the New Zealand Government. This was announced in the N.Z. Parliament last week by the Minister of Mines, who said that the report of a U.K.A.E.A. geologist who has spent more than a year investigating the possibilities was "most discouraging".

I suppose you might say that this makes New Zealand definitely non-'U'!

★ WITH U.K. synthetic rubber production scheduled to rise from the early 1960 level of 90,000 tons a year to something like 200,000 tons a year in the next few years (see Leader, p. 419), it is not surprising that there will be a strong representation from this country at the German Rubber Society Congress to be held in Berlin from 4 to 7 October. Nearly 1,000 scientists from 30 countries are expected to attend.

The newer synthetic rubbers polybutadiene and polyisoprene, which are very close to natural rubbers in their properties, will be the subject of a number of

papers. Of particular interest will be a paper by Professor G. Natta on a new copolymer of ethylene and propylene. The same must hold for the lecture to be given on the ethylene-vinyl acetate copolymers, which also promise to become interesting elastomers.

★ LAUNCHING of Albright and Wilson's new phosphate rock-carrying motor vessel *Arthur Albright*, reported in page 390 of last week's issue, illustrates the time-honoured business policy of 'spending a shilling to save a pound'. When you have to fetch your raw material from such far-flung points as Florida and North Africa, freight rates can have quite a big effect on the profitability of manufacturing phosphorus and other products. There have certainly been some big fluctuations in North Atlantic freight rates since the war. By designing a ship specifically to carry phosphate and by building to the limitations of length and breadth imposed by the ports which it is likely to use, the company expect to make considerable cost savings.

Four of the subsidiaries of A. and W.—two in this country, one in Canada and one in Australia—are large users of phosphate rock. The new ship has been designed primarily to carry phosphate from Florida for the Oldbury and Portishead phosphorus factories of A. and W. (Mfg.) Ltd., currently the largest phosphate user in the group.

★ NEXT week CHEMICAL AGE starts serialising 'Scientific Russian Without Tears' by Professor Perry of Arizona University. Coincidental with this came an order from the Kremlin for a copy of 'Manana Becomes Today,' a travel book by CHEMICAL AGE director, Neil Wallace. Light reading for Mr. Krushchev on his way to New York perhaps?

★ FROM 'moonshine' to 'noonshine'. That is how the latest development in fluorescent lamps strikes me. No one can deny that the early claims of fluorescent lamp makers that their products gave artificial daylight could aptly be described as 'moonshine', although they were a big improvement on the tungsten filament lamp. With their new fluorescent lamp, the A.E.I. Lamp and Lighting Co. have come a long way in the attempt to reproduce daylight. In fact their new lamp could accurately be described as 'noonshine'.

The light given by the new tube is described as being "in the noon sunlight region", due to a special blend of phosphors. A.E.I.'s heavy research spending over a long period in their search for

a 'group of phosphors that would give the right lighting effect paid off when four compounds were combined. These were: strontium magnesium orthophosphate, strontium halophosphate, calcium halophosphate and magnesium fluorogermanate.

With this formula, A.E.I. researchers were able to reproduce the spectral energy distribution inherent in a mixture of north sky light and mid-day sunshine.

★ BACK from a visit to the Farnborough Air Show, my attention was drawn to work being done on the evaluation of liquid methane and propane as fuels for the next generation of jets. The U.S. National Aeronautics and Space Administration's Lewis Research Centre, Cleveland, is seeking new fuels because as jets fly faster and higher, more and more excess heat from the engines must be dissipated.

The most efficient way to do this is to 'dump' the heat into the fuel just before it is used—liquefied methane can absorb about five times as much heat as current jet fuels, and about twice as much as even the most highly refined kerosene-type fuels. The problems of cooling the natural gas to a liquid and keeping it that way on the ground and in the plane are formidable, but not insurmountable.

Insulating materials only  $\frac{1}{4}$  in. thick in the tanks would keep the liquid fuel cool during flight. These normally gaseous fuels are said to be superior to conventional fuels in their combustion performance, burning with better efficiency and at higher altitudes. Liquefied natural gas has the added advantage that it would cost only one-quarter to one-half the current price of conventional jet fuels.

★ CONGRATULATIONS to the Stockton-Billingham Technical College in persevering with a general science course for chemical plant supervisors and others. Last year this course attracted such a small number of students that it had to be dropped after a few weeks. Doubtless foremen and chargehands in the area were scared off by the impression that they would be faced with incomprehensible chemical formulae and obtuse mathematical symbols.

But the few stalwarts who attended last year from the I.C.I. Billingham Division were disappointed that the course had to be abandoned. Backed by demonstrations and film shows, it was designed to provide an appreciation of the basic principles in chemistry and physics underlying local industries.

Now the college is including the subject in their syllabus for the current session. If it can overcome the counter attractions of television, it should give those attending a better understanding of the processes they handle.

*Alembic*

# CHEMICALS AND PLASTICS MAKE BIG CONTRIBUTION TO FARNBOROUGH AIR SHOW

WHILE focal-point of the Farnborough Air Show continues to be the flying display, in recent years the accompanying exhibition has clearly demonstrated the dependence of modern aircraft and missiles on the chemical and allied industries. The 1960 exhibition of the Society of British Aircraft Constructors was no exception and enabled the thousands of trade and other visitors to appreciate the vital contribution that technological advances in chemicals, plastics and metallurgy are making in this age of jets and rocketry.

One of the most interesting exhibits was that of the Ministry of Aviation's **Rocket Propulsion Establishment** at Westcott, Bucks, which deals with all aspects of the design and development of both solid propellant and liquid propellant rockets. This exhibit showed some of the techniques developed at Westcott to study the processes taking place inside the combustion chamber and exhaust nozzle of a liquid propellant rocket engine.

Because of the difficulty and expense of conducting systematic experimental work on large engines, two special combustion chambers have been built to represent a small segment of the complete rocket engine. Both chambers use a propellant combination consisting of n-heptane fuel burning in decomposed hydrogen peroxide and they produce about 300 lb. thrust at 500 p.s.i. operating pressure.

## Test Probes

A water-cooled cylindrical combustion chamber that can be operated continuously for long periods was shown on its test stand. Probes can be inserted in the chamber and in the exhaust streams to extract gas samples for chemical analysis. This makes it possible to assess the extent of chemical reaction and the degree of mixing. A special design feature of the probes enables the sample to be rapidly expanded to low pressures to prevent condensation and to stop any further chemical reaction.

Kanigen-plated gun blast tubes now being fitted on the English Electric Lightning were displayed on the **Albright and Wilson (Mfg.) Ltd.** stand as an example of the way in which this chemically-deposited plate resists extremes of corrosion and erosion. The mild steel tubes, 0.003 in. plated all over, have to withstand considerable shock at a point where the hot and corrosive burnt cordite gases are at their most turbulent.

The Ardrox range of metal cleaning materials, including paint removers and degreasants, was demonstrated by **Brent Chemical Products Ltd.**, Brentford, Middlesex. Special emphasis was placed

on chemical brighteners and crack detection materials.

A new high-temperature torch—the plasma-jet—was shown for the first time. Designed by **British Oxygen Research and Development Ltd.**, it is particularly suitable for applying coatings of high melting point or reactive material by spraying.

Successfully deposited arc high melt-

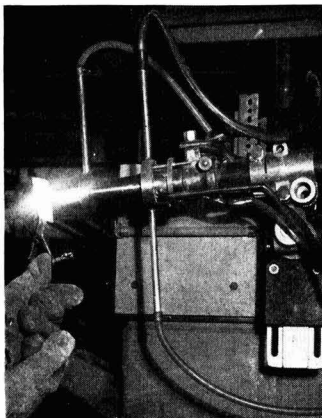

Plasma-jet torch for applying coatings of high-melting point or reactive material by spraying

ing point materials such as zirconia, alumina, and titania; refractory and reactive materials including tungsten, tantalum and silicon; chemically-resistant materials such as titanium and stainless steel, and wear-resisting materials like tungsten-carbide and nickel-chromium-boron alloys.

Possible uses for the plasma-jet include the coating of rocket nose cones with refractory and wear-resistant materials, and the coating of steel parts with titanium and stainless steel and the application of hard wear-resistant coatings.

The same company is developing a miniature expansion turbine, less than 3 in. long. Intended as a cooling unit in air liquefaction apparatus, its specially designed air-lubricated bearings allow high rotational speeds with a substantial saving in weight and bulk and a high efficiency level. With the turbine, air or any other gas can be cooled without contamination by lubricants.

P.R.C. synthetic rubber sealants and coatings for sealing and protecting integral fuel tanks, pressurised areas and electrical equipment were displayed by **British Paints Ltd.**, 303-306 High Holborn, London W.C.1. These are produced by the company's Elastomers Division, under licence from the Products Research Co., Los Angeles.

Refrasil, a virtually pure silica-fibre,

high-temperature thermal insulation material that is light in weight and highly resistant to thermal shock was exhibited by **British Refrasil Co. Ltd.**, Stillington, Co. Durham. A subsidiary of Darlington Chemicals Ltd., the name of this company has been changed to Darchem Engineering Ltd. Among new products on view were welded fabrications made possible by the company's experience with very thin stainless steel. One showed a method of fitting integral lagging to pipes to allow for longitudinal expansion of up to  $\frac{1}{2}$  in., without disturbing the insulation or reducing its effectiveness.

Samples of Astrasil, an ablation material made from Refrasil cloth impregnated with a phenolic resin and intended for use on missile nose cones, blast tubes and deflector vanes, were also shown.

Redux and Hidux adhesive system for load-bearing metal structures were displayed by **CIBA (A.R.L.) Ltd.**, Duxford, as were their Aeroweb lightweight honeycomb core materials and Araldite epoxy resins.

The **Graviner Manufacturing Co. Ltd.**, 79 St. James's Street, London S.W.1, exhibited a range of safety devices including a new smoke detector, a compact lightweight unit unaffected by voltage variation and possessing fast response characteristics and a new sealed H.S.R.S. detector. A fully hermetically sealed unit which meets A.R.B. and F.A.A. requirements and is capable of being set to detect at temperatures from  $-50^{\circ}\text{C}$  to temperatures in excess of  $500^{\circ}\text{C}$ . Also new was a flame detector, capable of detecting a flame of a match in broad daylight at a distance of 30 ft.

Centrepiece of **Fothergill and Harvey Ltd.**'s stand was an interior bulkhead for the Vickers *Vanguard*, made from Tyglas reinforced plastics. The cloth used was Garan finished Y094 Tyglas quality P6/225/E. The resin comprised Bakelite SR17449 resin, Q17448 accelerator, Q17447 catalyst, Cereclor 70 and antimony oxide.

A feature of the **I.C.I. Metals Division** stand was an illuminated chart showing how prices of their titanium have been reduced in recent years. Products included wrought copper and copper alloys, wrought zirconium, beryllium, niobium and other new metals. **I.C.I. Plastics Division** on a neighbouring stand displayed examples of their Melinex polyester film, p.t.f.e., Perspex, Diakon, etc.

The largest single manufacturers of hydrogen peroxide in West Europe, **Laporte Chemicals Ltd.**, Luton, featured H.T.P. as a safe, controllable, compact and instantaneous source of propulsive energy for aircraft and missiles. A cut away model of a section of a rocket motor, showing the H.T.P. system, was displayed. On their outdoor stand, Laporte gave regular practical demonstrations of the use of the Metk-lens range of A.I.D. approved metal cleaning products. Also demonstrated were the properties of H.T.P. and its comparability with constructional materials. Associated with these exhibits were displays of Laporte organic

peroxides for use as polymerisation initiation catalysts.

M.O.R. fluids for the non-destructive detection of flaws, including the Britemore fluorescent process and specialised oil products, were displayed by **Manchester Oil Refinery (Sales) Ltd.**, 76 Jermy Street, London S.W.1 **Marston Excelsior Ltd.**, Wolverhampton, showed Marlite and Flexelite flexible fuel tanks, heat exchangers in light alloy, titanium and stainless steel, together with laminated plastics components.

The latest developments in fluid control were shown and demonstrated under power by the **Saunders Valve Co. Ltd.** Details of the latest models are the hardened spherical plug, thin rubberised-fabric annular diaphragms, '0' ring augmentation of sealing—all of which successfully withstood the 5 million operations endurance test. Examples of the versatility of this design were seen in valves for H.T.P., L.O.X., R.F.N., and other aviation and rocket fuels and also

operational fluids such as hot air and gases, water methanol, oxygen and nitrogen. The flap type non-return valve was exhibited in its latest form together with non-return valves for special fluids and for duties involving high and low temperatures.

New data on the Nimonic heat-resisting series of alloys in sheet forms was featured by **Henry Wiggin and Co. Ltd.**, Millbank, London S.W.1. Data was included on a new sheet alloy in the series which has been developed as a result of research on the effects of heat-treatment on the welding qualities of the Nimonic heat-resisting alloys when used in sheet form. With an increasing interest in discs to work at higher operational temperatures, considerable research has been made into the melting and subsequent forging of high-nickel containing creep-resisting alloys for this purpose; enabling much larger billets of Nimonic 90 nickel-chromium alloy to be made available.

## 'Interfirm Comparison' Director Hopes Chemical Industry Will Join Scheme

AT a meeting held in London last week to report on progress of the first year's working of the Centre for Interfirm Comparison—an organisation set up by the British Institute of Management in association with the British Productivity Council—hope was expressed by Mr. H. Ingham, director of the Centre, that the chemical industry might in due course be brought within the scheme. He explained that the chemical industry presented great difficulties for making interfirm comparisons because the industry was to a large extent dominated by two groups—I.C.I. and Distillers.

More important, perhaps, is the fact that there are, in the chemical industry, so many diverse products involving such different costs and margins. Some comments on this point were made at another meeting by Dr. F. L. Gilbert, managing director of the Durham Chemical Group Ltd. (see CHEMICAL AGE, 30 April, p. 717), who felt, however, that there was a good opportunity for comparing notes on the cost ratios of common stages in the technology of the product without disclosing a company's own expertise.

Pharmaceutical manufacture seems to be a field more immediately amenable to exchanges of data between firms, and

a scheme for pharmaceuticals is in fact being prepared by the Centre for Interfirm Comparison in conjunction with the Association of the British Pharmaceutical Industry. Other industries for which schemes are in preparation include the paint industry and the rubber industry, while a scheme for scientific instruments is about to be launched in association with S.I.M.A.

'Interfirm comparison' means the provision to management of figures which will help to show, firstly, how the performance of its firm compares with that of other similar ones, and secondly, what the reasons for differences are. It is based upon the idea that however satisfactory the performance and progress of a firm may appear from internal records, the only true test of success is that provided by the achievements of other firms.

## South Africa Imposes Dumping Duty on U.K. Caustic

The Union of South Africa has imposed an ordinary dumping duty on caustic soda imported from the U.K., the U.S. and Italy. The duty is in addition to any other duty payable and also applies to caustic soda imported under rebate of duty facilities.

## I.C.I.-Monsanto-Polymer to Have Joint Stand at Mansa Exhibition

AMONG exhibitors at the Mansa convention of the Man-made Soling Association to be held at the Cafe Royal, London, from 4 to 6 October will be a joint exhibit by three companies, the only Commonwealth producers of styrene/butadiene copolymer rubber reinforcing resins. These are the I.C.I. Plastics Division, Monsanto Chemicals Ltd. and Polymer (United Kingdom) Ltd.

These companies will show the derivations, aspects of production and some applications of these materials. Also exhibiting are the International Synthetic Rubber Co. Ltd. (Intol styrene/butadiene rubber) and Joseph Crosfield and Sons Ltd. (Alusil 165 aluminium silicate and Microcal 210 calcium silicate—two white fillers for incorporation in either natural or resin rubber compounds.)

## Bradford Institute Offers Research Posts

A BOOKLET issued by the Bradford Institute of Technology described the research carried on in the Department of Chemical Technology. It gives some account of the research opportunities, the current research and the papers published and successful theses during the past five years.

The department has a long tradition of fundamental research and over the past ten years, higher awards have been made by several universities to research students in the department. With the development of the Institute as a College of Advanced Technology, accommodation, facilities and the provision of specialised equipment for research have been very considerably expanded and an increased number of research posts have been made available. Current fields of research include high polymer chemistry, chemistry and histology of fibrous proteins, radiochemistry, chemistry of natural products, and chemical engineering.

## Production Index for Chemicals

Board of Trade index of industrial production, based on a 1954 average of 100, gives an index of 145 for the chemicals and allied industries in April, compared with 134 in April 1959, and 145 in the first quarter of 1960. The April index for general chemicals, etc., was 147 (135 in April 1959, and 147 in first quarter 1960). A later figure is given for coke ovens, oil refineries, etc., the June index being 132 (126 in June 1960, and 137 in the first quarter 1960).

## British Firms Exhibit at Bulgarian Trade Fair

For the first time the British exhibit at the Bulgarian International Trade Fair, to be held at Plovdiv from 18 September to 2 October, is under the official patronage of the Government. Among the firms exhibiting are Griffin and George (Sales) Ltd., and Solartron Electronic Group Ltd.

## Klinger-Smith Joint Valve Exhibition

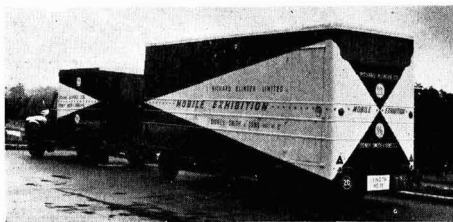

Richard Klinger / Sydney Smith mobile exhibition unit now touring the U.K. with exhibits of high-pressure jointings, rubbers, sleeve packed cocks, valves and level indicators from Klinger and gauges, valves and thermometers by Sydney Smith



# R.I.C. MEMBERSHIP PROPOSALS UNDER FIRE

## Lively Discussion by London Section Members

**P**ROPOSALS of the council of the Royal Institute of Chemistry for new grades of membership met with opposition at a recent meeting of the London Section. While most speakers supported the council's proposal for a licentiate-ship, there was little or no support for the registered members clause. About 80 members were present and Mr. F. C. Hymas was in the chair, accompanied by Dr. H. J. T. Ellingham, R.I.C. secretary and registrar, and London Section officers.

Mr. Hymas briefly described the proposals, reminding members of the two main suggestions, i.e., one for licentiate-ship and the other for a registered group. The proposals had deliberately been presented many months before any decision on them was likely to be taken so that members should have ample time for consideration and discussion.

Mr. L. M. Miall (Kemball, Bishop and Co.) opened discussion by offering some criticism of the proposals, maintaining that they were by no means clear. Was a Higher National Certificate in chemistry regarded as an equivalent to a pass degree or not? What was meant by a 'non-corporate' member? If it implied complete absence of voting rights then he would deplore it. Was there not a danger of a licentiate being regarded as a failed graduate?

### Changing Attitude

He felt that the attitude towards the Institute qualifications was changing and the prestige of such qualifications was rising due to the changes made in the R.I.C. regulations. He believed that the Institute should serve all qualified chemists but did not feel that the proposals for licentiate-ship as presented so far would necessarily serve that end. He regarded the proposal concerning registered members as a disturbing one and was not prepared to support such a proposal at present.

Dr. Ellingham said the present intention was certainly that licentiate-ship should be non-corporate and should not have the voting rights. It was impossible to draw strict comparisons between Institute qualifications and university degrees and even more difficult to draw comparisons between pass degrees and the H.N.C. The widest difference usually existed in the general standard of education, rather than in theoretical knowledge so that in the final instance each case had to be decided on its merits.

Mr. P. A. Raine (Crown Cork Co.) supported Mr. Miall in deploring the absence of voting rights for licentiates, particularly if they were to be regarded as a permanent grade of membership. A probationary period of one or two years prior to granting voting rights

might be justifiable but certainly not permanent deprivation.

Mr. D. M. Freeland (Macfarlane, Lang) referred to the number of years that the matter has been under discussion by the council and reviewed the changes in qualifications for membership which had occurred during that period. It was a process of evolution and it should not be forgotten that there were still quite a number of unqualified chemists (by R.I.C. standards) who had risen to quite high positions in the profession and who had themselves controlled the work of Institute qualified men. He would welcome some method of widening coverage of people in the chemical profession, but the method adopted must provide safeguards against any lowering of existing standards in graduatship, associateship and fellow-ship.

Dr. Ellingham stressed that no lowering of existing standards was expected to occur; in fact there was good reason to believe that the introduction of some lower grade could heighten the status of existing grades, for such had been the experience elsewhere.

Expanding on his earlier comparisons between qualifications, he said that graduatship was regarded as being equivalent to a good honours degree, therefore it was essential that the Institute should allow only those H.N.C. candidates with a general education up to pass degree standard to proceed to the graduatship. In reply to a further question by Mr. Freeland, Dr. Ellingham said that there would be no bar to licentiates proceeding to associateship possibly by taking Part II of the graduate examination.

Mr. Miall felt that the standard of experience for a licentiate-ship should be similar to that for a graduate member.

### Third Grade Inevitable

Dr. S. A. Miller (British Oxygen Research and Development) described the present position concerning a third grade of membership as one arising from modern conditions which was inevitable. Its introduction must not detract from the existing qualifications and therefore the standards for a licentiate-ship must be pitched as high as practically possible. Although those proposals were put out by council before he became a member of it, they had his support so far as the third grade was concerned, but not on that concerning registered members. In present circumstances he regarded this latter suggestion premature. He also found some difficulty in defining a non-corporate member and did not support the proposal to deprive them of voting rights. He believed that the significance of designatory letters was now declining.

Mr. C. T. Ashton (Southwark Borough Council) supported the proposals for a third grade and suggested the word 'member' instead of licentiate-ship. He had grave doubts concerning the registered grade.

Mr. N. Lindop (Kingston Technical College) speaking on behalf of teachers in technical colleges, believed that the licentiate-ship proposal would be universally welcomed and he could guarantee that it would lead to no lowering of standards. Some students could reach Part I standard of the R.I.C. exam but would never reach Part II; surely some recognition of that achievement should be available to them. Wholesale recognition of H.N.C. was not asked for nor considered desirable, for neither he nor his colleagues would regard it as necessarily equivalent to Part I of the R.I.C. exam. He would like to see some actual examination equivalent to Part I and some practical tests insisted on before licentiate-ship was ever granted, with little, if any, exemption from it. He did not regard the proposed register of members as serving any useful purpose.

### Doubts About Benefits

Doubts on any benefits arising from licentiate-ship were expressed by Mr. I. C. R. Bews (British Titan Products). Institute meetings and publicity were aimed at its present members and he did not believe that those with lower academic attainments would gain any advantages from them. Some quite competent chemists were unwilling to proceed to graduate membership and he did not believe that admission of them into the Institute could do anything but lower its status as a responsible organisation.

Mr. D. J. Emery (Alexander Duckham and Co.) posed the eternal question of what is a chemist? The R.I.C. existed to define a chemist, yet it could not completely do so—if corporate membership represented professional status then licentiate-ship could not do so if it were regarded as a non-corporate grade. He questioned any advantages which licentiates might gain and enquired whether any approach had been made to the Institute from those likely to benefit.

Mr. H. Warson (Vinyl Products) declared that it could bring nothing but benefit to the Institute if those who could not qualify eventually for associateship could be brought in. He believed that all with H.N.C. should eventually be admitted, maintaining that there was little to choose between a pass degree and H.N.C. in chemistry. The Institute must remember that part-timers found full general educational qualifications difficult to obtain, for standards had risen enormously during the past 10 years. The recent Crewe meeting called by the British Association of Chemists was a symptom of the pressure in that direction and if the Institute did not provide a niche for those people, someone else would.

Mr. J. R. Barr (N.W. Kent College of Technology) said there was much in favour of both the new proposals, especially the licentiate-ship. Many chemists not at present in the Institute were well qualified, either academically

or by industrial experience and there should be means of encouraging them to join the R.I.C. He made the following suggestions for admission as licentiate, (a) a good H.N.C., (b) one year's further study, (c) adequate industrial experience and (d) recommendation of two corporate members. There was no necessity for an additional Institute examination and he did not regard the subject of voting powers of great importance.

*Mr. R. G. Browning* (Ministry of Labour) discussed the changing needs in qualifications of workers in chemistry. There was a need for a qualification applicable to technicians whose duties might be most serious and responsible although of a routine nature. Some registration under the auspices of the Institute was certainly desirable, but those registered need not be part of the Institute. On the proposed third grade he regarded licentiate as the only possible way; 'Member' was dangerous, for in many other institutions that was a senior grade. Some qualifications between 'A' level and graduateship was needed for the good types in practical chemistry who were not particularly of academic bent; such people found examiners much more difficult to satisfy than their own chiefs, who were after all usually better judges of their value in the profession.

### "With One Voice"

*Mr. M. Clark* (British Oxygen Gases) supported the proposal for licentiate. The worker with H.N.C. and practical experience might be a much better chemist than a new graduate, although the latter would soon overtake the former. There was some underemployment of graduates and many positions now filled by them could be undertaken with those of lower qualifications. The profession would suffer if there were a proliferation of chemical institutions (as in engineering) and the Institute should speak with a united voice. The new grade was much more likely to heighten the status of existing qualifications rather than to lower them.

Opposition to the proposals came from *Mr. J. A. Hill* (Shell Petroleum) who maintained that the Institute had no obligation to cater for those who just had not made the grade. Much of what he had read and heard smacked of sympathy, which was very misplaced. The status of the profession must be upheld and the present proposals would automatically lower it as represented by the Institute. If some other organisation was now necessary there was no reason why the Institute should oppose its formation and he felt that if the additional revenue accruing from more subscriptions was a factor it must be dismissed as a quite unworthy motive.

*Mr. P. F. Corbett* (Shell-Mex and B.P.) strongly opposed both proposals. The conditions of part-time training at present were no worse than in the past and might in many quarters be considered much better. Any man who called himself a chemist could achieve graduate status if he were prepared to do so.

*Mr. G. E. J. Reynolds* (Vinyl Products)

supported the proposal for licentiate. He regarded a graduate as equivalent to an honours degree and those below H.N.C. level not as chemists but chemical assistants. Therefore licentiate should include those possessing H.N.C., Part I or a pass degree. He thought a licentiate should not have voting rights but after suitable experience might be promoted to the associate grade.

*Dr. Ellingham* said that the discussion had followed similar lines and covered many points which had emerged at other meetings and it would be of much value to the council in its final deliberations. He reminded the meeting that chemistry was no worse than medicine in the complexity of its qualifications, consequently any decision as to where the line of corporate membership of the Institute should be drawn was not going to be easy.

The question of corporate membership was one of terminology and might

well be reviewed. One of their greatest difficulties in dealing with H.N.C. candidates was the widely varying standard of general education; undoubtedly some were as good as many honours graduates but some could be below G.C.E. 'O' level. The council was concerned to provide the best for the profession and the meeting could be assured that it would not fail in its task. Universally it was clear that there was little support for what had been described as a fourth grade and at most that proposal should be deferred. He reminded the meeting that at present graduates did not require experience but the proposed licentiates would invariably be practising chemists of some experience. Those difficulties would not easily be ironed out particularly in arranging for transition to associate. On the other hand he reminded the meeting that none of these proposals affected those leaving universities with a good degree.

## Marking Code for Multiwall Sacks Sought by Waste Paper Industry

CONCERN has arisen in the paper industry at the increasing use of paper containers embodying special treatment and barrier materials; for instance, in packaging, there is a widespread use of wet strength agents, metal foils, waxes, vegetable parchments, plastics and cellulose films, latex adhesives, asphalt, etc. As a result of the use of such materials, the paper industry, which relies on salvage for nearly 30% of its raw materials, is faced with the growing hazard of the contraries in the waste paper recovery system. The additives serve a valuable purpose but most of them make waste paper difficult or impossible to repulp.

A special committee is to be set up by the British Standards Institution to help investigate the problems involved, its specific task being to examine the prospects of a coding system for complex multiwall sacks. The decision is the result of a meeting sponsored by the British Waste Paper Utilisation Council and attended by leading members of the paper and multiwall sack-using industry.

The paper industry wants sacks coded so that they can be accurately identified and segregated at an early stage in the process of recovery.

The first practical step in a proposed scheme is to print an identifying mark on multiwall sacks which incorporate contraries. Such a step already has the moral support of a number of sack users, due to the efforts of the British Waste Paper Utilisation Council. The task of the British Standard Institute special committee is now to evolve a standard code-mark which can be easily recognised but yet doesn't require the use of extra colour or clash with existing surface designs.

A coding system was recently introduced by the Heinz tinned food company, who asked suppliers who deliver raw materials in multiwall sacks, to indicate the presence of contraries by a broad red band. As a result, waste paper disposal has been made both efficient and profitable since accurate segregation of plain from treated sacks has raised the recovery value by about £10 a ton.

## D.S.I.R. Research on Roof Vents

RESEARCH carried out to determine principles for the design of roof vent installations from the point of view of fire safety has been extended to deal with the effect of roof venting on fires. Two models have been used, representing one bay of a factory separated from the rest of the building by a fire curtain, extending part of the way from the ceiling to the floor. The first experiment has been completed and a theory evolved which can be used to calculate the depth of curtain and area of vent required to prevent hot gas being discharged beneath the curtain when a factory bay contains a fire which is

either localised or spreading slowly.

The second study has concerned the effect of opening a vent on the speed at which a fire progresses. Experiments have been made to measure the rate of burning of wooden cribs inside the model. Opening a vent has been shown to increase the rate of burning if this is restricted by the air flow, but it also releases smoke and by increasing the efficiency of burning, improves visibility and assists fire-fighting.

These experiments are discussed in the latest report of the Fire Research Board (published for the D.S.I.R. by H.M.S.O., 5s) which covers the year 1959.

# Graft Polymerisation of Styrene on Pre-irradiated Polythene Described

WHEN polythene is irradiated with  $\gamma$  rays the main effects observed are the production of hydrogen, the cross-linking of the polymer and the formation of unsaturation at points along the chain, i.e. the formation of a trans-vinylene group (Lawton, Balwit and Powell, *J. Polymer Science* 1958, 32, 257), said Dr. T. T. Jones of Monsanto Chemicals Ltd. in his paper on 'The graft polymerisation of styrene on to pre-irradiated polyethylene' at the B.A. annual meeting in Cardiff on 2 September. He was speaking during a symposium on polymers. The production of hydrogen is associated both with the cross-linking reaction and the formation of unsaturation.

It results in the first place by the primary radiation event breaking a C-H bond on a polymer chain, thus forming a polymer radical and a hydrogen atom. The hydrogen atom then attracts another hydrogen atom from a nearby polymer chain forming hydrogen and another polymer radical. The two polymer radicals are sufficiently proximate to combine and so cross-link the two polymer chains; on the other hand they may be restrained from doing this owing to the crystal structure or physical condition of the polymer. They then become trapped radicals.

In the second place the hydrogen is believed to result from the loss of two hydrogen atoms from adjacent  $-CH_2-$  groups on the same chain. This also results in unsaturation.

## Study of Kinetics

The paper focused attention on the trapped radicals that are formed and discussed their use as active points of grafting of polystyrene chains on to the polythene chains. The kinetics of the graft polymerisation have been studied.

In the method used the polymer is irradiated preferably in vacuo or in an inert atmosphere so as to produce trapped radicals as described. These initiate the graft polymerisation of subsequently admitted monomer.

Polythene of molecular weight about 44,000 was chosen for a number of reasons: it is reasonably radiation sensitive; it is largely insoluble up to temperatures of about 70°C and would thus be a suitable substrate for the formation and retention of trapped radicals; it is partly crystalline and the effect of the grafted polymer on its crystallinity and other physical properties was of direct technical interest.

Styrene is a suitable monomer since it is reasonably reactive and is absorbed at equilibrium by polythene to the extent of 11.1, 20.0 and 53.0% at 20°, 40° and 60°C respectively. (Charlesby and Pinner, *Ind. des Plastiques Modernes*, 1959, 9, 43.

The paper dealt with three parameters: (1) the temperature of irradiation, (2) the time of standing after irradiation and (3)

the temperature of polymerisation. The time of irradiation was kept constant namely 24 hours and each irradiation was carried out in a continuous vacuum.

*Experimental.* The polythene used was a sample of H.P.P.E. which had been precipitated from a well stirred cooling solution of about 50 gm. of the polymer in 900 ml. hot xylene by means of 750 ml. absolute alcohol. The polythene was allowed to settle and subsequently filtered and washed with absolute methanol and partly dried on the filter. This was further dried in a hard vacuum at 50°C. The resulting polymer was in the form of a fine white powder of molecular weight 44,000, determined viscometrically in xylene at 95°C in a suspended level dilution viscometer using the usual Harris relation. The powder had a maximum particle dimensions of the order of 100 $\mu$ .

The irradiation and the polymerisation were carried out in a dilatometer of about 10 ml. capacity as shown in Fig. 1. About 1 gm. of the polyethylene powder was placed in the bulb of the dilatometer which was fitted with a vacuum tap and a B.14 socket. Prior to irradiation, the polythene contained in the dilatometer was evacuated in a hard vacuum for at least an hour at 50°C. The evacuated dilatometer containing the polyethylene was then placed in a Dewar vessel with the bulb of the dilatometer touching the inner wall of the Dewar so as to reduce to a minimum the attenuation of  $\gamma$  rays

traversing the cooling or heating medium contained in the Dewar. While in this position the dilatometer was continuously evacuated during its irradiation which was effected by means of a  $Co^{60}$   $\gamma$ -ray source of about 75 Curies in the form of a cylinder 7.5 cm. high and 1.25 cm. diameter placed with its axis parallel to and 5 cm. from the axis of the dilatometer bulb. The average dose rate in this position was estimated to be approximately 450 Roentgens per minute.

Each sample of polythene was irradiated in continuous vacuum at the desired temperature for 24 hours so that the dose received was about 650,000 Roentgens. A sample of polythene irradiated at 150°C under the present experimental conditions contained some insoluble gel, i.e. after a dose of about 0.65 megaroentgens.

After irradiation, the polymer could be left at any desired temperature for a fixed time and then the correct quantity of pure degassed styrene needed to fill the dilatometer to a suitable height of the stem was admitted by slow distillation into the liquid nitrogen cooled dilatometer bulb. In this way, it was ensured that little or no reaction of the trapped radicals with the incoming styrene took place. Occasionally, however, the bulb had to be warmed by hand in order to melt the frozen styrene and hence fill the bulb to the required degree. The dilatometer was then completely evacuated of any non-condensable material and sealed.

Polymerisation was carried out by immersing the dilatometer in a thermostat bath at the temperature required and observing the height of the meniscus in the capillary with time. The initial rate of polymerisation was very difficult to

(Continued on next page)

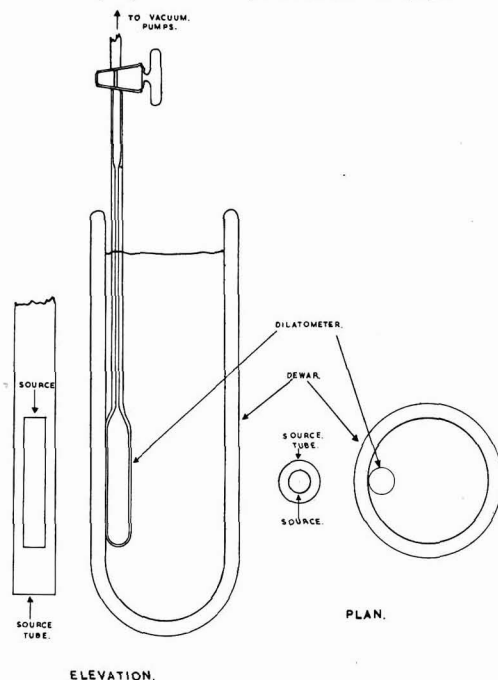

Fig. 1. Experimental arrangement for irradiation

define since it took a definite time of about 8 minutes before the temperature of the dilatometer contents was at the temperature of the bath. From a knowledge of the density of styrene and of polystyrene at the temperature of polymerisation it is possible to transform a decrease in volume of the styrene into a yield of polymer. Since the polymer is formed by grafting on to the polythene the reacting volume has been considered to be the volume of polythene present. This should be corrected for by the increase in volume of polythene due to absorption of styrene but at the main polymerisation temperature this is only of the order of 15% and the volume of polythene has thus been regarded as virtually unchanged. The amount of polystyrene formed has thus been expressed to a first approximation, in basic moles per initial litre of polythene.

Concluding, Dr. Jones said that the graft polymerisation of styrene on to pre-irradiated polythene by reaction at the trapped radicals had been shown to be greatly influenced by the rigidity of the swollen polymer gel in which the polymerisation takes place. A considerable reduction in termination coefficient compared with reaction in the free monomer due to the immobilisation of the polymeric radicals was observed. The resulting grafted structure exhibited features in the dynamic mechanical damping properties which were attributed to the inability of the polythene to crystallise fully.

It was clear that degree of grafting might be easily controlled by extent of dose or time of ageing irradiation, while the extent of polymerisation was determined by time or temperature of polymerisation.

## I.U.P.A.C. and Reinforced Polyester Resins

UNDER the sponsorship of the Plastics and High Polymers Division, International Union of Pure and Applied Chemistry a conference on 'Reinforced polyester resins' will be held in Torino (Italy) on 28 September with speakers from France, Germany, U.K., U.S., U.S.S.R. and Italy. Lectures so far announced include: G. Tolley (U.K.): General introduction; R. R. Stromberg, G. M. Kline (U.S.), 'Adsorption of polyesters and other polymers to glass and

other substrates'; G. Dubois (France), 'Standardisation and test methods of reinforced polyester resins'; M. Lenzini (Italy): 'New realisations in different fields of fabrication of articles of reinforced polyester resins.'

The conference will take place in the Salone dei Congressi dell'Unione Industriale di Torino: Via Vincenzo Vela, 17. Further information can be obtained from Prof. A. G. Nasini, Direttore, Istituto Chimico dell'Università, C. so Massimo d'Azeglio, 48, Torino, Italy.

## Shell Will Stress Petrochemicals Growth at Macroplastics Exhibition

WITH an exhibition stand covering more than 3,800 sq. ft. of floor space, the Royal Dutch/Shell Group of companies will be represented at the international plastics exhibition Macroplastics 1960, which will be held in Utrecht, from 19-26 October.

The exhibit has been planned between Group companies in Holland and the U.K. The products to be displayed are styrene/butadiene, polyisoprene and polybutadiene rubbers; Epikote resins; polystyrene, polythene and polypropylene plastics.

Another section will draw attention to the vast research behind these products and to technical service laboratories which provide customers with advice on

the latest developments in products and techniques.

A large part of the stand will be attractively furnished and reserved for discussion purposes. Here the visitor will see a display of various end-products and will have ample opportunity to discuss technical problems with staff from Shell companies throughout Europe.

The exhibit will stress the importance of oil as a source of an ever-increasing variety of chemical products, including plastics, synthetic rubbers and resins. It is estimated that, in 1959, Europe's chemical industry alone used about 1.5 million tons of refinery and natural gas and some 2.5 million tons of crude and refined oil for the manufacture of chemical products.

## Pure Food Centenary Celebrations in London

IT WAS in 1860 that the first general law governing the quality of food was passed. With the Act for preventing the Adulteration of Articles of Food and Drink, Britain was the first country to take steps in general pure food legislation. Since then her example has been followed by the Commonwealth and many other countries. It is to celebrate the centenary of the original Act that an international conference, including lectures, exhibitions, visits and social events, is to be held in London from 20 to 23 September.

Papers will trace the significance of the 1860 Act and its influence on the purity of food throughout the world, and particular emphasis will be laid upon the importance of the scientific research which is undertaken by Government and industry research organisations.

At an exhibition to be held at Charing Cross underground station, some indication of the advance made in food science and technology in the last 100 years, will be given by the representation of two chemical laboratories of 1860 and 1960. It is believed that it is the first time that a working chemical laboratory has been put before the general public to show something of the work of the public analysts and of the chemists of the food industry.

## Common Market Course for U.K. Executives

A TWO-DAY course, organised by the Federal Trust for Education and Research and Britain in Europe, and with the theme, 'The progress of the Common Market and its effects on the United Kingdom', will be held at the Londoner Hotel, Welbeck Street, London W.1. on 27 and 28 October. Speakers will include Mr. H. W. Vallender, head of the Commercial Department, Association of British Chemical Manufacturers.

This course, which is designed for business executives and those concerned with the developments inside the European Economic Community, will deal, among other subjects, with agreements and associations within the Common Market and the effectiveness of various methods of British penetration.

Further information can be obtained from The Course Secretary, Federal Trust for Education and Research, 10 Wyndham Place, London W.1.

## Drawback on Linters Imported for Filter Papers

The Board of Trade are considering an application for the allowance of drawback of duty imported purified cotton linters, having a total iron impurity content of not more than 10 p.p.m. when used in the manufacture of filter paper for export. Representations which interested parties may wish to make should be addressed in writing to the B.o.T. Tariff and Import Policy Division, Horse Guards Avenue, London S.W.1, not later than 7 October.

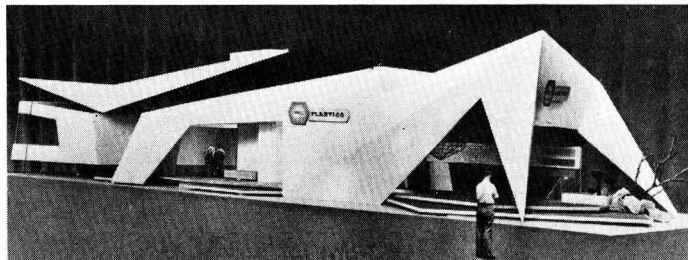

Model of the Royal Dutch/Shell Group stand



## Overseas News

### WEST GERMANY RAISES CHEMICAL OUTPUT 17%, BUT INVESTS LESS THAN U.K.

OVER the first half of the current year, turnover of the West German chemical industry totalled DM11,300 million (£942 million), or 17% more than that for the same period of 1959. This figure excludes the Saar, since this was not an economic part of West Germany in the first half of last year.

The production index of the West German chemical industry rose by 17½ points over the same period to a monthly average for the first 1960 half-year of 310 (1938 as 100). This is set against a fall in prices over the period to a monthly average price index of 183 (1938 as 100), as compared with 185 over the first half of last year. Biggest fall in prices was in the field of organics, which despite the dynamic growth of petrochemicals fell in average price by over 6%.

DM1,700 million (or about £142 million) were invested in West Germany's chemical industry last year, or 3% above the figure for the previous year. This is remarkably little when compared with the 1959 production increase of 14% over 1958. While the country's chemical industry spent 9.3% of its turnover on investments in 1958, this share dropped to 8.4% last year. For the current year it is estimated that a new record of DM2,000 million (some £167 million) will be invested. In the period 1948-1959, West Germany's chemical industry has invested rather over DM11,000 million, which compares with DM13,500 million in the case of the U.K. and DM59,000 million for the U.S.

#### Persia Seeks Three Nitric Acid Units

Tenders for the purchase of three nitric acid retorts are sought by 8 October by the Armament Department, Imperial Army, D.T. Section, Avenue Jaleh, Teheran, Persia.

#### Carbon Dioxide from Sierra Leone

A plant is now being set up at the Sierra Leone Oxygen Factory at Kissy, near Freetown, for the production of carbon dioxide. The Sierra Leone Oxygen Factory, which opened in May of this year, at present produces quantities of oxygen and acetylene.

#### Austrian Reichhold Plant £1.8 Million Expansion

Reichhold Chemie AG, the Austrian member of the international Reichhold group, are to spend Sch.150 million (£1,875,000) on plant expansion over a period of five years. The company, which has just changed its name from Reich-

hold Beckacite Chemische Fabrik AG and decided on a capital increase of Sch.5 million, is next autumn to open a large-scale plant for the production of plastics.

#### French A.E.C. to Erect Plutonium Plant

The French Atomic Energy Commission has decided on the erection of a plant for the chemical production of plutonium from activated uranium in existing atomic piles in France. Probable site for the plant, which will process uranium from plants erected by the Commission at Chinon and in the Arée hills and from the Electricité de France plant at Marcoule, is Cap de la Hague—the tip of the Cotentin peninsula. Some 1,000 workers will be employed at the plutonium works.

#### Santophen I Extension for Monsanto Chemical

Monsanto Chemical are extending their Monsanto, Ill. plant to provide double capacity for Santophen I, a phenolic germicide.

#### Allied Chemical Expand Caprolactam Capacity

The National Aniline Division of Allied Chemical has started operations to expand caprolactam monomer capacity at Hopewell, Va. When the extension is completed in the summer of 1961, it will raise the company's 84 million lb./year capacity to 140 million lb./year. Expansion projects to raise capacities of caprolactam polymer and nylon 6 at Chesterfield, Va. are already in hand by the company.

#### Canadian Firm's Naphthalene Plant on Stream

Record Chemical Co. Inc., Montreal, have extended their existing plant with the addition of a unit which started producing refined naphthalene, with a minimum melting point of 70°C, at the end of August.

#### Spanish Government Rejects Two Petrochemical Plans

Two out of the four applications to set up petrochemical plants in Spain have been rejected by the Government (see CHEMICAL AGE, 25 May, p. 885). Authorisations were refused to one project submitted by Union Espanola de Explosivos S.A., in conjunction with the Royal Dutch-Shell Group and another by Compania Espanola de Petroleos S.A., in co-operation with Standard Oil of New Jersey.

One of the projects authorised refers to the agreement between Dow Chemical International and Union Quimica del Norte de Espana S.A., which covers the setting up of an olefin plant and units for butadiene, polythene, polypropylene, polystyrene, etc. (see CHEMICAL AGE, 3 September, p. 357). The other project which has been authorised (C.A., 23 July 1960), is the largest involving a refinery and petrochemical plants at Puertollano, about 150 miles north of Malaga, with which port, the plants will be connected by pipeline. This scheme was submitted by Calvo Sotelo.

#### Loan for Chile Salt Factory

The Corporation de Fomento de la Produccion is to grant a loan of 285,740 escudos to the Compania Salinas de Punta de Lobos for a mechanisation and development programme for the salt factory and loading installations at Salar Grande and Puerto Pailillos in Chile. The company plans to raise annual production from 50,000 tons to 180,000 tons, of which 100,000 tons will be exported.

#### Caustic Output Below Capacity in Argentina

The estimated annual production of caustic soda in Argentina, at 33,000 to 34,000 tons, does not meet the installed capacity of 60,000 tons. Failure to make full use of the available capacity is attributed mainly to the import of a large volume of caustic soda at low prices.

A decrease in the estimated consumption of caustic soda for 1958 and 1959 over the previous years is shown, the figures being 62,000-65,000 tons as opposed to 70,000-75,000 tons.

#### U.S.I. Double Capacity for Polythene Resins

A new extension, doubling plant capacity, has been brought on stream at Houston, Tex. by the U.S.I. Division of National Distillers. U.S.I.'s capacity for low and medium density polythene resins is now 300 million lb./year.

#### Mexico Impose Import Restrictions

The Mexican Ministry of Trade has placed phenacetin and wintergreen oil on the list of goods requiring an import licence for entry into the country.

#### Cellulose in First Shipment from Newest Atlantic Port

The first cargo to be shipped on the dedication day of the New Brunswick State Docks, contained 1,100 bales of chemical cellulose. Destined for Belgium, the commodity was produced 35 miles west of the new Atlantic coast port at the Jesup division of Rayonier Incorporated. The two mills comprising the Jesup division have an annual capacity exceeding 200,000 tons of chemical celluloses and paper-making pulps.

Rayonier also produce cellulose for both domestic and foreign consumption at mills in the Pacific Northwest, in

Canada and at Fernandina Beach, Florida. World demand for the company's celluloses has shown steady growth over the last 10 years, with overseas orders accounting for some 50% of total business. The company views overseas markets as another opportunity for further expansion and foresees a "continuing upward trend in overseas sales of cellulose for the long term."

### Polymer Industries Opens New U.S. Plant

The U.S. company, Polymer Industries Inc., producers of industrial adhesives and textile speciality polymers, have dedicated their recently-completed \$1 million plant expansion. The new plant expansion, started in March 1959, includes a solvent mixing plant and a polymerisation plant, which will produce polyvinyl acetate as one of its chief products. In addition the new plant will enable the firm to develop and produce its own specialised polymers designed for specific purposes. The polymerisation plant has been designed to give space for additional reactors when needed and includes cooling and blending tanks.

The new solvent mixing plant will enable Polymer Industries to expand greatly their production of solvent-based as opposed to water-based products. These products, which are generally solutions of natural or synthetic rubber or synthetic resin polymers, are used where water cannot be introduced into the system.

### Western Consortium Promote New Refinery Project in Pakistan

A new oil refinery with an initial capacity of 1.5 million long tons/year of crude is to be built near Karachi by a new company, Pakistan Refinery, which has been formed by a consortium consisting of Burmah Oil, Caltex, Shell Petroleum and Standard Vacuum Oil. They will have a 60% interest in the venture, the remaining 40% being Pakistani.

Construction contract has been awarded to Kellogg International Corporation and Bataafse Internationale Petroleum Mij. Construction and commissioning will cost Rs.107 million. The plant is expected to be operating in the second half of 1962.

### Argentina Doubles Polythene Import Duty

The import duty on liquid, powder and solid polythene imported into the Argentine has been increased from 40% to 80% of the c.i.f. value.

### Phillips to Expand Marlex Plastics Capacity

Phillips Chemical are adding facilities to their plant near Houston, Texas, to raise production of Marlex plastics to 100 million lb./year, an increase of about one-third. Construction will be finished in several phases so that Phillips can be supplying the increasing needs of their customers before completion of the entire

expansion programme next year.

A feature of the expansion programme is the versatility it will permit in expanding the supply of resins tailored to specific end uses. New manufacturing techniques are said to impart improved characteristics to Phillips resins for many important fields of use.

### Raffinage-El Paso Polythene Project in France

In association with El Paso Natural Gas, Compagnie Francaise de Raffinage, of the Compagnie Francaise des Petroles Group, are to produce polythene and other plastics materials from feedstock supplied by the French company's Normandy refinery. Each company will hold a 50% interest in the project. Polythene capacity will be 20,000 tons/year, with production scheduled to begin in 1963.

Raffinage are raising their ethylene output from a current 30,000 tons/year by building a new steam cracker with a 50,000 tons/year capacity.

### Dow Plastics Technical Service in Italy

Dow Chimica Italiana S.p.A., a subsidiary of the Dow Chemical Co., U.S., have established a plastics technical service for their customers in the European area. The service operation will assist users of Dow plastics materials in their proper application and in manufacturing techniques.

A new polystyrene production plant is now under construction near Leghorn.

### Soviet Chemicals and Plant for Russia

Under a technical and economic aid agreement signed between Ghana and the Soviet Union, the U.S.S.R. is to supply quantities of chemicals and industrial plant to Ghana.

### Mexican Firm to Make Fluorocarbons with U.S. Aid

The Mexican company Celulosa y Derivados S.A. plan the erection in Monterrey of a new plant for the production of hydrofluoric acid and fluorocarbons. A further plant planned by the company will produce carbon tetrachloride necessary, while chlorine and

carbon disulphide will come from the firm's subsidiary, Sosa de México S.A., and sulphuric acid from another Celulosa subsidiary. The Mexican firm plans to work in co-operation with the Allied Chemical Corporation in its new project.

### Phillips Plan Liquid Gas Sales in Europe

Phillips Petroleum Co. are planning to build a 20,000-tonne liquid gas container near Rotterdam for the storage of liquid gas before selling to the European chemical, ceramic, glass and gas industries. The same company is undertaking studies to determine whether there are markets in Europe for additional Venezuelan natural gas. If sales of the product stored in Holland—mainly from Venezuela, the Middle East and the Sahara—pass a certain level, Phillips intend to place orders in Europe for gas tankers.

### New Hooker Bulletin Gives Data on 94 Chemicals

Data on physical properties, applications and type of shipping container for 94 organic and inorganic chemicals produced by Hooker Chemical Corporation, U.S., for industry and agriculture are contained in a new bulletin, No. 100-D, obtainable from Hooker at P.O. Box 344, Niagara Falls, N.Y. The list is comprised of 88 commercially produced chemicals and six development products. More than 20 new or recently developed chemicals are included.

The bulletin includes certain acids, alkalis, the elements chlorine and phosphorus, metallic salts, phosphorus compounds, sulphur compounds, chlorides, chlorobenzenes, and additional chemicals of the Eastern Chemical, Western Chemical, and Phosphorus Divisions, other than Hooker's custom-made products.

### Australia to Admit Duty-free Imports of Fluorspar

In newly revised customs by-laws, the Australian Department of Customs and Excise is to admit until further notice imports of acid or ceramic grade fluorspar duty free under the British Preferential Tariff. The revision also applies to activated alumina.

## Sulphuric Acid from Copper-Nickel Concentrates in Canada

OPENING of a sulphuric acid plant near Transcona has given Manitoba its first basic chemical industry. Border Chemical Co. Ltd., who operate the plant, point out that the \$1 million unit, is the only commercial producer of sulphuric acid between Sudbury, Ontario, and Fort Saskatchewan, Alberta. Besides providing sulphuric acid for industry at prices much lower than those for imported acid, the plant is expected to revitalise mining in eastern Manitoba.

With a capacity to produce about 75 tons/day of acid, the plant started operations using raw Alberta sulphur. But it

is equipped to use copper-nickel concentrates, mined in the Bird River area near Lac du Bonnet, as a source of sulphur. In this process, the concentrates are heated to give off the sulphur dioxide which is then processed to produce the acid.

The process leaves the copper and nickel ore lighter than normal, reducing costs of shipping it to smelters. The Bird River mining operations previously produced low grade ore that made shipping and smelting uneconomical; with this new use, development of the mine is feasible.

● **Mr. E. Korner**, a director of S. G. Warburg and Co. Ltd., has been appointed a director of Aspro-Nicholas Ltd., Slough, Bucks.

● Guest speakers at the largest-ever international conference on natural rubber—to be held in Kuala Lumpur from 26 September to 1 October—include **Professor G. E. Blackman, F.R.S.**, Oxford, and **Professor Geoffrey Gee, C.B.E.**, Manchester. More than 250 delegates will hear 80 papers to be presented in two sessions covering research on the production of natural rubber and research on the preparation and use of natural rubber and latex.

● **Mr. E. P. Hudson**, managing director of Scottish Agricultural Industries Ltd., Edinburgh, has been appointed to



E. P. Hudson

serve under the chairmanship of **Sir Harry Pilkington** on the Committee on Broadcasting which is to advise the Government on the future organisation of British television and radio services. Mr. Hudson is chairman of the Scottish Technical Education Consultative Council and convener of the Industrial Liaison Committee, Edinburgh University.

● **Mr. C. E. Dixon**, head of the transport and warehouse department of Glaxo Laboratories Ltd., Greenford, has received a gold watch marking 40 years' service with the company which he joined as an accounts clerk. Mr. Dixon is a past-chairman of the London Division of the Industrial Transport Association of which he is a fellow and was founder 11 years ago of the West Middlesex Manufacturers' Transport Group of which he is still chairman.

● **Mr. G. R. Vila**, a group vice-president of the United States Rubber Co., will be chairman of Sto-Chem, the new company formed jointly by Witco Chemical and U.S. Rubber to produce synthetic rubber latices in the U.K. (see 'Project News', p. 421). **Mr. D. Roberts**, who has been manager of manufacturing for Witco's U.K. operations, will



D. Roberts

## PEOPLE in the news

leave that post to become general manager of the new firm.

● **Mr. F. C. Bagnall**, managing director of British Nylon Spinners Ltd., Pontypool, Mon., has been appointed a companion of the Textile Institute.

● **Mr. E. H. S. van Someren** has recently joined the British Welding Research Association as a principal scientific officer and is to work on fundamental studies on the physics of

the welding arc by optical observations. Since 1958 he has been in the research department of Murex Welding Processes Ltd.

● **Mr. J. R. Moore**, manager of the Fisher Governor Co. at the Rochester factory of the Elliott-Automation Group, has been appointed assistant general manager of the Elliott Valve Group, which, in addition to Fisher Governor, includes James Gordon Valves Ltd., Farris Engineering Ltd., and Black Automatic Controls Ltd.

● **Mr. Herbert W. Vallender** of the Association of British Chemical Manufacturers is making his second visit to Canada this year in connection with the Tariff Board's hearing on chemicals. At the session opened this week, the Canadian chemical industry is calling for a 'blanket' tariff of 15% British preferential for chemicals imported from the Commonwealth and 20% for 'most favoured nations' imports. There are some exceptions to this 'blanket' proposal.

● **Mr. D. H. du Rieu** has been appointed to the board of Metalife Corrosion Ltd., an associated company of Metalife Liquid Metals Ltd., Harrogate, which he joined in 1957 as technical manager.

## TRADE NOTES

### Precious Metal Thermocouples

When the length of life and maintenance factors of precious metal thermocouples and their high scrap value are taken into account, the cost of using precious metal thermocouples does not compare unfavourably with the use of base metals. This is the view expressed in the latest thermocouple publication produced by Engelhard Industries Ltd., Baker Platinum Division, 52 High Holborn, London W.C.1. The publication gives data on the different types of precious metal thermocouples, including recommended sheaths and indicators. Calibration tables are also included.

### Effluent Treatment

The treatment of industrial liquid effluents by neutralisation, oxidation, reduction, precipitation and other methods is discussed in an illustrated pamphlet issued by Acalor (1948) Ltd., Kelvin Way, Crawley, Sussex. In the main section of the pamphlet, effluents containing acids, alkalis, cyanides, chromates, phenols, metals and organic matter are discussed, the various methods available being compared from the point of view of efficiency and cost.

### Formica Fire Hose

A light and flexible fire hose has been produced by Formica Ltd. by the extrusion of P.V.C. around and through a Terylene sleeve. The result, say the manufacturers, is a tough, homogeneous material with an easy tolerance to high pressures, the impossibility of pin-holing and rapid drying speed. The hose is supplied in standard lengths of 75 ft., and initially in two sizes of 2½ in. and 2¾ in. bore at a cost of 5s and 5s 6d per ft. respectively.

### Solvent Systems

Suggested solvent systems for Harcure A-epoxy formulations are given in technical data sheet No. 19A issued by the Geigy Co. Ltd., Plastics Chemicals Division, Rhodes, Middleton, Manchester.

### Antimony Price Increases

Increases in the prices of antimony and antimony products have been announced by Associated Lead Manufacturers Ltd. The price increases are £8 per ton for Timonox red star and 'O' quality antimony oxide in 5-ton lots and £10 per ton for Tynebrand (99%) antimony metal (10 cwt. and over); 'C' brand (99.6%) in 10 cwt. and over; and for black powdered.

### Change of Address

As a result of increasing expansion Bayer Products Ltd., a member of the Winthrop Group, are moving their offices on 19 September from Kingston-on-Thames to Winthrop House, Surbiton-on-Thames, Surrey. The telephone number—Kingston 7733—remains the same.

### Cambridge Instruments

A number of instruments are described in publications issued by the Cambridge Instrument Co. Ltd., 13 Grosvenor Place, London S.W.1. List 331/1 describes the Cambridge pneumatic temperature measuring system, designed to provide non-electric indication and recording at considerable distances from the point of measurement. The Numalec controller, described in temporary list 310, is tailor made to give accurate programme control for temperature/draught or pressure in chemical processes.

## Commercial News

### A.P.V. Company

The A.P.V. Company is to make a one-for-five scrip issue of ordinary and the directors forecast the same rate of dividend for 1960, namely  $8\frac{1}{2}\%$ , as for the previous year, but on the larger capital. This is revealed in an interim report to shareholders in which the chairman, Mr. W. E. Jenkins, says that the final results for the year should show an improvement over those for 1959. The overall result for the first six months' trading is better than for the same period last year, in spite of the fact that competition in some markets is having an adverse effect on profit margins.

Group sales also are up on those for the same period of 1959, particularly in the parent where the total of orders booked to date is "very encouraging". Factory production is at a higher level.

### Aspro-Nicholas

Trading results of Aspro-Nicholas Ltd. for the June quarter enable a first quarterly dividend of  $3\frac{1}{2}\%$  to be paid on capital increased by a three-for-two scrip issue, for the year ending 31 March 1961 (equivalent of 2.6%).

### Burt, Boulton

In his annual statement, Mr. Howard C. Hitchcock, chairman of Burt, Boulton and Haywood Ltd., said that the subsidiary Alchemy Ltd. had maintained their position in the naphthenate and ester fields. Referring to the Belgium plant at Selzaete, he declared that the company had secured increased quantities of tar on a long-term contract. Production of phthalic anhydride was at a very high level and there was good ground for thinking that future activities at Selzaete should produce satisfactory profits. There was also a prospect of further development and a major project was now being studied.

The associated company, Burts and Harvey Ltd., continued to make encouraging progress in the establishment of their chemical business at Southampton. As stated in 'Project News,' South Western Tar Distilleries Ltd. and Alchemy Ltd., have new phthalic anhydride and maleic anhydride plants in hand, respectively.

### Evans Medical

The whole of the share capital of J. Gilbert Jackson Ltd., wholesale chemists, Sheffield, has been acquired for cash by Evans Medical Ltd., Liverpool. Evans Medical are the parent company of the Evans Medical Group, which has branches all over the world. Last year the group's earnings increased by 20% to £397,896.

### Reichhold Chemicals

Reichhold Chemicals Ltd. are maintaining the interim dividend for 1960 at  $7\frac{1}{2}\%$  on capital increased by a one-for-eight scrip issue and a subsequent one-for-four rights issue. Dividends totalling

- One-for-five Scrip Issue by A.P.V.
- Burt's Expanding Chemical Interests
- Reichhold Interim on Increased Capital
- Stewarts & Lloyds Acquire Staveley

not less than the previous  $22\frac{1}{2}\%$  were forecast for this year when the rights issue was made.

### Staveley Iron and Chemical

The second largest of the steel companies which are still State-owned, Staveley Iron and Chemical Co., has been sold to Stewart and Lloyds by the Iron and Steel Holding Realisation Agency for £6 m. The book value of Staveley's is £8.2 m.

### Steeley Co.

Profits before tax of the Steeley Co. Ltd. for the first half of the year were £1,357,123 (£1,131,829). After tax of £692,123 (£550,829), net profit was £665,000 (£581,000). Interim dividend of 5% (4%) is declared. It is proposed that the £1 ordinary shares be divided into 5s shares.

### Allied Chemical

Merger talks between the Allied Chemical Corporation and the American Potash and Chemical Corporation have been broken off.

### ANIC

The Italian petrochemical concern ANIC, in whom the Italian State concern ENI have a majority holding, are to double their share capital, which now stands at Lire 18,000 million. ANIC last year recorded a net profit of Lire 840 million and paid a 9% dividend on capital of Lire 7,200 million.

### Californie-Atlantique

Californie-Atlantique, set up in France in April by California Chemical S.A., a Swiss subsidiary of the Standard Oil of California concern Oronite Chemical Co., and French interests for the erection of a petrochemical plant at Donges, have raised their capital from N.Fr.4,500,000 to N.Fr.7 million. The French interests in the company—the Pechelbronn group, Progil, the Worms et Cie. banking house and the Sofibanque—are the shareholders of the newly-formed Société Pétrochimique de l'Atlantique, who own the petrochemical company together with Oronite.

### Friedrich Uhde GmbH

Friedrich Uhde GmbH, Dortmund, have increased their capital from DM1,200,000 to DM5 million, while Farbwerke Hoechst AG, Frankfurt-on-Main, have raised their holding in the concern from 70% to 77.5% of total capital. A corresponding fall in capital share has resulted for the only other shareholder, Dr. Friedrich Uhde, of Dortmund. Friedrich Uhde GmbH, who

are concerned in the planning and construction of chemical plant, are reported to have had a turnover of some DM85 million, or well over £7 million, last year.

### National Chemical Products

National Chemical Products, South Africa, recorded for the financial year 1959-60 a turnover of £3,200,000 (£2,800,000) and a net profit of £410,000 (370,000). A total of £120,000 (£110,000) was paid on an unchanged dividend of 2s 6d.

### Péchiney Saint-Gobain

Produits Chimiques Péchiney Saint-Gobain, the company set up by the two French chemical producers Péchiney and Saint-Gobain last year for the organisation of joint production of certain basic chemicals and plastic materials, have been transformed into a French joint stock company with a capital of N.Fr.1 million. The company's board is made up half of Péchiney and half of Saint-Gobain staff, with Paul Viollet of Saint-Gobain as first managing director.

### Pétrochim

Société Chimique des Dérivés du Pétrole, the Belgian petrochemical producers better known as Pétrochim, are to raise their capital from B.Fr.700 million to B.Fr.790 million, the new shares being issued at par.

### Vick Chemical Co.

Vick Chemical Co., U.S., are changing their corporate name to Richardson-Merrell, Inc. The new names are those of Vick's founder and the founder of Wm. S. Merrell Co., a division of the company which produces prescription drugs. Stockholders will vote on the name change on 18 October, and approval is expected to be automatic.

Earnings for year ended 30 June were \$14,380,848 (\$12,156,819) or \$3.22 (\$2.71) a share.

### NEW COMPANIES

CHEMEK REFINERS LTD, Cap. £5,000. Manufacturers of and dealers in chemicals and plastics, drugs and other pharmaceutical preparations, laboratory equipment, etc. Directors: D. S. Pryke, M. S. Coomber, H. Hupston. Reg. office: 50 Stoke Newington Church Street, London N.16.

RUMBLE McCOLL LTD, Cap. £100. Manufacturers of and dealers in food preservatives, chemicals, etc. Directors: D. H. Rumble and J. E. Rumble. Reg. office: Hales Street, London S.E.8.



# HYDROGEN PEROXIDE

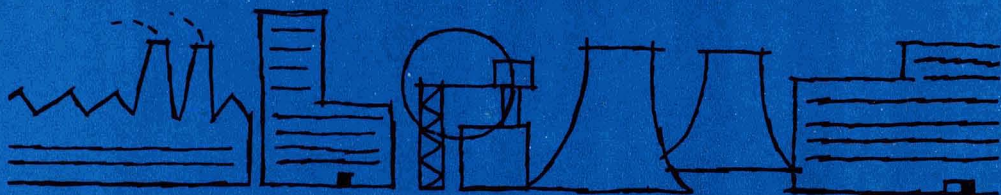

IS  
USED  
IN  
INDUSTRIES



ALL  
OVER  
THE  
WORLD.

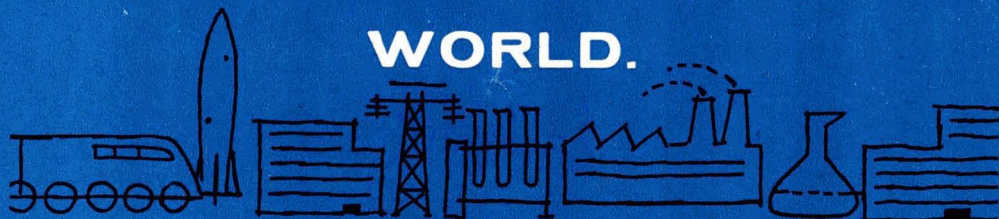

**LAPORTE** *of course!*

... are the largest manufacturers of Hydrogen Peroxide  
in the British Commonwealth.

# NEW PATENTS

By permission of the Controller, HM Stationery Office, the following extracts are reproduced from the 'Official Journal (Patents)', which is available from the Patent Office (Sales Branch), 25 Southampton Buildings, Chancery Lane, London W.C.2, price 3s 6d including postage; annual subscription £8 2s.

Specifications filed in connection with the acceptances in the following list will be open to public inspection on the dates shown. Opposition to the grant of a patent on any of the applications listed may be lodged by filing patents form 12 at any time within the prescribed period.

## AMENDED SPECIFICATION

On Sale 5 October

Organopolysiloxane elastomers. General Electric Co.  
Polymeric films. Du Pont de Nemours & Co., E. I.

## ACCEPTANCES

Open to public inspection 12 October

Process for the production of titanium boride coatings. Metallgesellschaft AG. 851 208  
O, O dimethyl-thiophosphoric acid derivative and pesticidal compositions comprising it. Montecatini Soc Generale Per L'Industria Mineraria E Chimica. 851 005  
Propanediol bis (thiocarbamates). Frosst & Co., C. E. 851 129  
Amine salts of aromatic acids, their use in herbicidal compositions and processes for their production. Amchem Products Inc. 851 008  
Chemical process. Du Pont de Nemours & Co., E. I. 851 063  
Ester synthesis. Esso Research & Engineering Co. 851 265  
Polymerisation and copolymerisation of alpha-methylstyrene and its derivatives substituted on the nucleus. Badische Anilin- & Soda-Fabrik AG. 850 909  
High impact polyvinylchloride formulation. Esso Research & Engineering Co. 851 028  
Polymerisation catalyst. Esso Research & Engineering Co. 850 910  
Purification of acrylic esters. Union Carbide Corporation. 851 342  
Process for the production of bis-heta-hydroxy-alkyl-terephthalates and isophthalates. Bataafse Petroleum Maatschappij N.V. 851 029  
Pyridone derivatives. Wallace & Tiernan Inc. 851 033  
Polymerisation of ethylene. Hercules Powder Co. [Divided out of 849 855.] 851 038

Open to public inspection 19 October

Manufacture of organic phosphorus compounds. Minister of Supply. 851 590  
Process for the preparation of 1:2:4-triazole-3-thiols. Kodak Ltd. 851 815  
Production of ammonium sulphate. Simon-Carves Ltd., Central Electricity Generating Board, and Council for Scientific & Industrial Research. 852 024  
Method of preparing esters. Goodrich Co., B. & F. 851 600  
Drawn polymers and process for the production thereof. Phillips Petroleum Co. 851 605  
Process and apparatus for the conversion of hydrocarbons. Lummus Co. 851 994  
Manufacture of solid, stable diazonium compounds. Farbwerke Hoechst Aktiengesellschaft Vorm. Meister, Lucius & Brining. 851 858  
Hydrocarbon polymers and process for production thereof. Phillips Petroleum Co. 851 893  
Cyclopentanophenanthrene derivatives and processes for the production thereof. Syntex S.A. 851 998

Polymerisation of olefines. Snia Viscosa Soc. Nazionale Industria Applicazioni Viscosa. 851 723  
Manufacture of melamine. American Cyanamid Co. 851 863  
Method of treating gases derived from the distillation of coal. Metallgesellschaft AG. 851 443  
Recovery of polymers from solution. Phillips Petroleum Co. 851 931  
Production of hydrous aluminas and aluminas. Spence & Sons Ltd., P. 852 041  
Transparent films from linear propylene high-polymers. Montecatini Soc. Generale Per L'Industria Mineraria E Chimica. 851 727  
Substituted dinitrophenyl pentenoates. Rohm & Haas Co. 851 907  
Copolymer emulsions. British Oxygen Co. Ltd. 851 535  
Preparation of rubbery interpolymer derivatives. Goodrich Co., B. F. 851 536  
Monoazodyestuffs derived from cyanuric halides, their application and production. Ciba Ltd. 851 537  
Polymeric materials. Montecatini. 852 042  
Water-insoluble azo dyestuffs derived from arylides of 2-hydroxy carbazole-3-carboxylic acids. Farbenfabriken Bayer AG. 851 538  
Preparation of polymeric mixtures and compounds. British Rubber Producers' Research Association. 851 731  
Hydrocarbon radiochemical conversion process. Esso Research & Engineering Co. 851 541  
Polymeric products. Du Pont de Nemours & Co., E. I. 851 936  
Apparatus for the preparation of gas mixtures containing hydrogen and carbon monoxide. Bataafse Petroleum Maatschappij N.V. De. 851 542  
Blended polymers. Monsanto Chemical Co. 851 491  
Preparation of 6-methyl steroid compounds. British Drug Houses Ltd. 851 741  
Acid-amide disazo-pigment dyestuffs and process for their manufacture. Ciba Ltd. 851 740  
Production of phthalocyanine dyestuffs. Badische Anilin- & Soda-Fabrik AG. 851 494  
Production of esters of phosphoric acid and thiophosphoric acid. Badische Anilin- & Soda-Fabrik AG. 851 495  
Amines. May & Baker Ltd. 851 373  
Preparation of organohalogenosilanes. Imperial Chemical Industries Ltd. 851 868  
2,3,5,6-tetrachloro-p-xylylene dithioacetic acid and derivatives thereof. Uclaf. 851 747  
Magnesium alloys. British Thomson-Houston Co., Ltd. 851 871  
Production of polybutene filamentary materials. Montecatini. [Addition to 810 023.] 851 872  
Vinyl chloride resin compositions. Union Carbide Corporation. 851 753  
Production of acrylonitrile. American Cyanamid Co. 851 496  
Production of silanes. Imperial Chemical Industries Ltd. 851 497  
Production of polymeric linear terephthalate ester films. Du Pont de Nemours & Co., E. I. 851 874, 851 875  
Preparation of 9-halo-11-hydroxyl-1,4-pregna-dienes. American Cyanamid Co. 851 501  
Process of preparing formaldehyde in stable form and formaldehyde-containing compositions produced thereby. Borden Co. [Addition to 838 097.] 851 876  
Therapeutic compositions containing ferrous fumarate. Glaxo Laboratories Ltd. 851 761  
Curing of copolymers of diverse mono-olefins. Cabot Inc., G. L. 852 035  
Method of adhering butyl rubber to metal. United States Rubber Co. 851 551  
Optical brightening of polymeric polymethylene terephthalates. Imperial Chemical Industries Ltd. 851 792  
Process for the production of cross-linked elastomers. Farbenfabriken Bayer AG. 851 553

Process for the production of diazo-azo compounds containing sulphonic acid groups. Farbenfabriken Bayer, AG. 851 903  
Fungicidal compositions and compounds for use therein. Shell Research Ltd. 851 795  
Anthraquinone dyestuffs and their use. Geigy AG., J. R. 851 557  
Fatty acid salts of chromium complexes of monoazo dyestuffs. Imperial Chemical Industries Ltd. 851 558  
Process for the production of terephthalic acid. Imperial Chemical Industries Ltd. 851 562  
Production of steroids. Gyogyszeripari Kutató Intezet. 851 563  
Primary amines of the heterocyclic series. Sandoz Ltd. 851 564  
Sparingly water-soluble heterocyclic azo dyestuffs. Sandoz Ltd. 851 909  
Substituted trifluoromethoxy- and fluoromethyl sulphones. Smith Kline & French Laboratories. 851 886  
Substituted trifluoromethyl- and trifluoromethyl-captophenothiazines. Smith Kline & French Laboratories. 851 951  
Solvent extraction process for separating hydrocarbons. Merck & Co., Inc. 851 567  
Heterocyclic azo dyestuffs of low solubility in water. Sandoz Ltd. [Addition to 851 973.] 851 910  
Process for the production of caustic alkali solutions from alkali metal amalgams. Imperial Chemical Industries Ltd. 851 461  
Polymerisation. Union Carbide Corporation. 852 019  
Acid addition salts of esters of substituted piperidyl phenyl methanols and processes for their production. Rhone-Poulenc. [Addition to 850 826.] 851 972  
Amides of phosphoric acid and thiophosphoric acid, and a process for the production thereof. Asta-Werke AG. 852 039  
Process of purifying maleic anhydride. Stamicarbon N.V. 851 570  
Pigments of the thiachromone series. Imperial Chemical Industries Ltd. 851 571  
Vinyl halide resin composition. Hoyt Metal Co. of Great Britain Ltd. (National Lead Co.). 851 974  
Polyethylene compositions. Union Carbide Corporation. 851 975  
Cross-linked polyesters of dicyclopentadiene dicarboxylic acids. Esso Research & Engineering Co. 851 772  
Linear quinacridone pigments. Du Pont de Nemours & Co., E. I. [Addition to 828 052.] 851 976  
N-vinyl-n-alkyl-2-oxazolidinones and their polymers. Dow Chemical Co. 851 773  
Polysiloxane compositions. Farbenfabriken Bayer AG. 851 575  
Process for recovering polymers from aqueous dispersions. American Cyanamid Co. 851 638  
Process for the dehydration of compounds containing one or more hydroxy groups and at least two conjugated double bonds. Farbenfabriken Bayer AG. 851 642  
Therapeutically useful carbamates and compositions containing them. Kabi A.B. 851 646  
Processes for the preparation of shaped objects based on polymerised substances. Soc. Des Usines Chimiques Rhone-Poulenc. 851 647  
Polyphenyl ether composition and their use as lubricant. Bataafse Petroleum Maatschappij N.V. De. 851 651  
Polymerisation of vinyl aromatic compounds. American Cyanamid Co. 851 657  
Production of methylheptenone. Metal & Thermit Corporation. 851 658  
Method for the preparation of polymerisation products. Bergwerksgesellschaft Hibernia AG. 852 051  
Synthetic polyamides. Monsanto Canada Ltd. 851 659  
Isomerisation of alkylated benzenes. Atlantic Refining Co. 851 576  
Tertiary amines and processes for their production. Thomae GmbH, K. 851 660

# "VULCAN" CARBOY HAMPERS SAFETY CRATES PACKED CARBOYS

HARRIS (LOSTOCK GRALAM) LTD. Lostock Gralam, Northwich, Cheshire

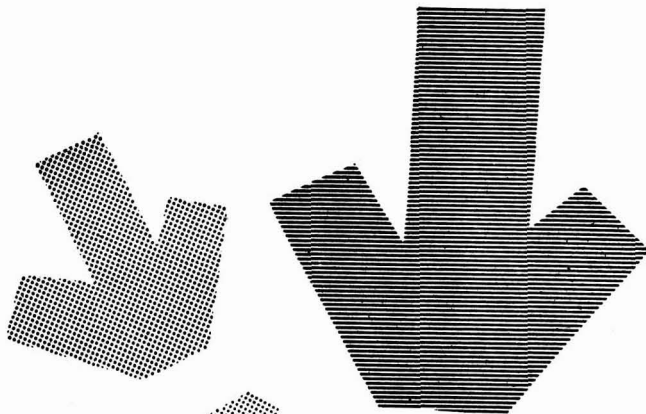

# Pristerene

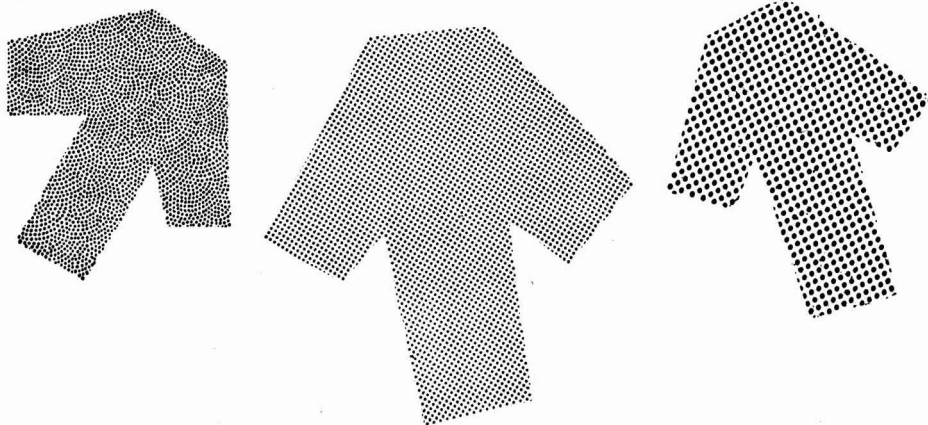

Pristerene is the registered trade mark for the stearines manufactured by Price's (Bromborough) Ltd. Industry at large has been prompt in recognising the many improvements offered by the Pristerene range—among them:

**STABILITY**, for greater resistance to rancidity and off-odours and colour incidence on heating—

**AVAILABILITY** (by guaranteed regular deliveries) in the form of Beads, as well as in Flake, Powder and Block—

**SPECIFICATION**—a comprehensive range to meet every industrial need.

**STEARINES  
OF EVEN  
HIGHER  
QUALITY**

Please write or 'phone your enquiry to:

**PRICE'S (BROMBOROUGH) LIMITED**

Bromborough Pool · New Ferry · Nr. Birkenhead · Tel: Rock Ferry 2020

OLEINES · STEARINES · FATTY ACIDS · FATTY ALCOHOLS · TEXTILE OILS





## Market Reports

### NITROGENOUS FERTILISERS IN DEMAND

**LONDON** Trading conditions on the chemicals market show little change on the week and prices remain steady with a firm undertone.

The movement to the chief home using industries against contracts is reported to be fully up to schedule, while overseas call has been satisfactory, covering a wide range of chemicals and allied materials.

Activity in the agricultural chemicals market is seasonally restricted, but there has been a fair demand for nitrogenous materials. Most of the coal tar products are moving steadily with available supplies finding a ready outlet.

**MANCHESTER** Quietly steady trading conditions have been reported on the Manchester market for chemicals and allied products. In the home section, leading industrial consumers are already mostly covered for supplies during the next two months or so, but spot and early delivery business has been on a fair scale. Bleaching, dyeing and finishing chemicals are being taken up in reasonably good quantities by the textile trades, and most other industrial outlets, including the plastics section,

are absorbing steady supplies. In the tar products trade, there is a continued demand for cresylic and carbolic acids, creosote oil, and most other lines.

**SCOTLAND** A rather more favourable position prevailed during the past week in the Scottish heavy chemical market. Buying was mostly concerned with immediate requirements, although there was some interest in forward bookings. Quantities showed little change and more or less remained at nominal levels. The range of chemicals was also more varied. There is still a prevailing quietness in regard to agricultural chemicals, although with the present weather conditions the demand for weedkillers is still moderately active.

#### Evening Lecture Course on Steroid Chemistry

A course of 11 post-graduate lectures on 'Recent advances in steroid chemistry' is to be held from 7-9 p.m. on Wednesday evenings, commencing on 28 September, at the Kingston Technical College, Fasset Road, Kingston-upon-Thames. Fee for the course is £1 2s 6d.

## DIARY DATES

#### TUESDAY 20 SEPTEMBER

**Pure Food Centenary**—London: Royal Institution, 21 Albemarle St., W.1, for 4 days.

**S.A.C.**—London: Royal Institution, 21 Albemarle St., W.1, 11 a.m. Special meeting on 'The chemist & food quality', to precede Pure Food Centenary Conference.

#### WEDNESDAY 21 SEPTEMBER

**Plastics Inst.**—Leeds: St. Mark's House, 186 Woodside, 7.15 p.m. 'Polycarbonates' by R. H. Cole & Co. Ltd.

**S.C.I.**—London: 14 Belgrave Sq., S.W.1. Three-day symposium on 'High temperature resistance and thermal degradation of polymers'.

#### THURSDAY 22 SEPTEMBER

**Inst. Gas Engineers with S.C.I.**—Birmingham: College of Advanced Technology, Gosta Green. Two-day symposium on 'Protection of gas plant & equipment from corrosion'.

**Inst. Plant. Eng.**—Liverpool: Exchange Hotel, 7.15 p.m. 'Some engineering problems with chemical plant', by J. C. Veale.

**S.C.I.**—Liverpool: Two-day symposium on 'Catalysts'.

#### Two-day Course on Plastics and Polymer Chemistry

A special short course on 'Recent developments in plastics and polymer chemistry' will be held at the Bradford Institute of Technology on 28 and 29 October, organised by Dr. W. R. Moore, M.B.E., B.Sc., Ph.D., F.R.I.C., reader in high polymer chemistry at the Institute. Fee for the course is £2 5s and further details are available from the Registrar, Institute of Technology, Bradford 7, Yorks.

THE ALL STAINLESS STEEL TANKER SERVICE

**FRED CHAPPELL LTD**

GRANGE ROAD • BATLEY • YORKS

Telephones : BATLEY 4242-3-4

EDIBLE OILS - SYNTHETICS - ACIDS Etc.

DELIVERIES THROUGHOUT THE U.K. or CONTINENT

CONTRACT OR SPOT HIRE RATES

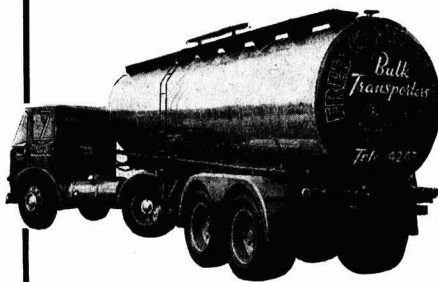

**KEEBUSH**

Keebush is an acid-resisting constructional material used for the construction of tanks, pumps, pipes, valves, fans, etc. It is completely inert to most commercial acids; is unaffected by temperatures up to 130°C; possesses a relatively high mechanical strength, and is unaffected by thermal shock. It is being used in most industries where acids are also being used. Write for particulars to—

**KESTNER'S**

5 Grosvenor Gardens, London, S.W.1

Decolorising **CARBON**

ALL GRADE  
FOR  
ALL TRADES

HIGHEST EFFICIENCY  
LOWEST PRICES

Granular Carbon for Solvent Recovery  
Regeneration of Spent Carbon

Write for samples and quotations.

**FARNELL CARBONS LIMITED**  
CONDUIT ROAD, PLUMSTEAD, LONDON, S.E.18

Telephone:  
Woolwich 1158 (2 lines)

Telegrams:  
Scofar, Wol, London



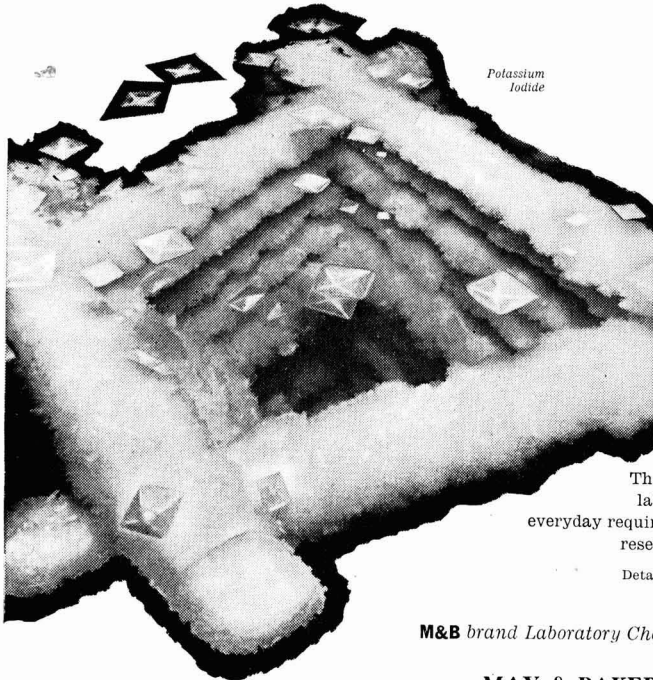

Polassium Iodide

## Interesting Facets

of chemical manufacture include the occurrence, from time to time, of unusual crystal "build-ups". This photograph was taken in one of the many May & Baker laboratories producing chemicals for use throughout the world. There are now more than 650 **M&B** brand laboratory chemicals available to cover the everyday requirements of academic, industrial, and research laboratories.

Detailed information is available on request

**M&B** brand Laboratory Chemicals and Reagents

MANUFACTURED BY **MAY & BAKER LTD** DAGENHAM · Tel: DOMinion 3060 · Ext. 320

LA569/85



### UNIVERSAL PORTABLE PUMPS FOR CORROSIVE LIQUORS

*Power or hand operated*

**EFFICIENT**  
**MINIMUM OF SPARES**  
**VERSATILE**  
**PORTABLE**  
**QUICK DELIVERY**

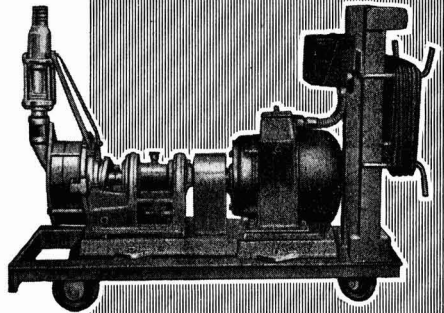

General service pump for acids and chemicals.

It will pay you to buy one of these general utility pumps for your works. Capacity 350 g.p.h. Total weight 65 lb.

Total head 30 ft.  
Suction lift 10 ft.

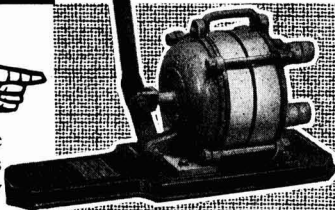

A robust power-pump for emptying sumps of acid, pumping effluents, emptying carboys, plating tanks and vessels and discharging chemical liquids and acids from road tankers. Capacity 780 g.p.h. Total head 20 ft. including a suction lift equivalent to 10 ft. of water. Fitted with 1½ h.p. motor.

**L. A. MITCHELL LIMITED**  
HARVESTER HOUSE, 37 PETER ST.,  
MANCHESTER 2  
TEL. BLA 7224/7 AND 7824/7  
LONDON OFFICE: PORTLAND HOUSE  
73 BASINGHALL STREET, LONDON, E.C.2.  
TEL. MET 8321/2

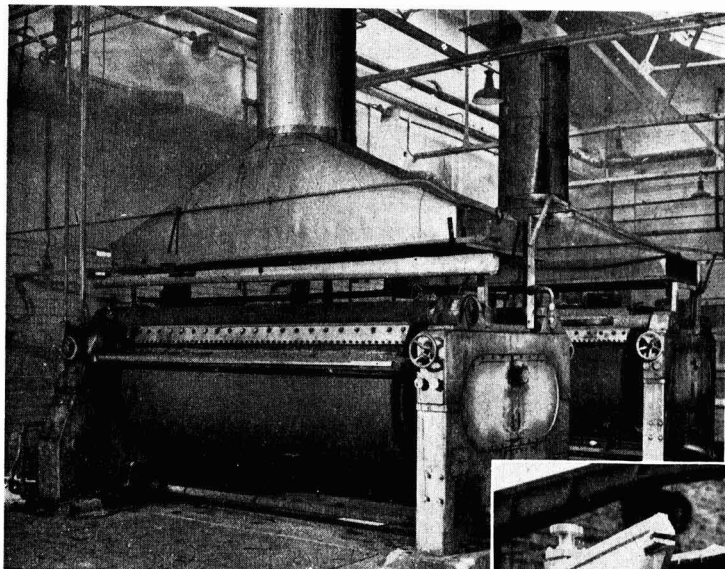

## Two TWIN ROLL BUFLOVAK DRIERS

by Consolidated Products of U.S.A.

rolls 100 in.  $\times$  32 in. suitable 100 p.s.i. w.p. Fitted scraper knives and aluminium hood with chimney. Driven through enclosed chains. Jones reduction gear with vee rope drive to 5 h.p. 400/3/50 cycles motor.

### ALSO AVAILABLE

**CONTINUOUS HORIZONTAL TROUGH MIXER.** Gardner type, 25 ft. 6 in.  $\times$  5 ft.  $\times$  5 ft. 8 in. deep. Trough constructed  $\frac{1}{2}$  in. mild steel plate, agitator shaft 24 in. dia. tube  $\times$  1 in. thick with 47 steel arms set at 90° with bolted on cast iron paddles 11 in.  $\times$  9 in. End discharge, counterbalanced, hinged aluminium cover. Driven through reduction gear from 75 h.p. motor.

**BUBBLE CAP COLUMN** in F.M.B. stainless steel, five bolted sections 23 $\frac{3}{4}$  in. dia.  $\times$  39 in. high and with five trays and ten bubble caps per tray. Flat division tray and four dished trays connected by rods and distance tubes.

**STAINLESS STEEL CLIMBING FILM EVAPORATOR** by Newman, chamber stainless steel construction, 3 ft. dia.  $\times$  4 ft. between flanges with bolted domed top, jacket with 1 in. connections, 6 in. flanged side vapour off-take and vertical tube 9 ft. 6 in. deep  $\times$  7 in. dia., with 2 in. connections.

**NO. 15 ROTARY DRUM DRIER** by Buell, approx. 26 ft. long  $\times$  5 ft. dia., flange bolted in two halves of  $\frac{3}{4}$  in. riveted steel construction. Drier on two roller paths, arranged for solid fuel firing. Complete with High Efficiency Cyclone, Fans, ducting, etc.

**ROTARY DOUBLE SHELL DRIER** by Edgar Allen, 16 ft. long  $\times$  3 ft. 4 in. dia. rotating on two roller paths driven through reduction gears by 5 h.p. motor, final speed 6.75 r.p.m. Oil fired with separate firebox, brick lined, Urquhart atomiser. Complete with cyclone, motorised fan. Inlet gas temperature 700/750 C, outlet 60° C.

**ROTARY DRIER** by Edgar Allen, size No. 54-24 ft. 7 in. long  $\times$  4 ft. 11 in. dia. running on two roller paths, having nominal rating of 10 tons per hour. Fitted with No. 6. size Mastoker Underfeed Stoker with capacity of 270 lbs. of coal per hour. Drive by 10 h.p. slipping motor through reduction gear. Complete with cyclone, etc.

**UNUSED AIR DRIER** by Kestner, comprising three 4 ft. dia.  $\times$  10 ft. deep on straight, welded mild steel absorption cylinders, suitable for 100 p.s.i.g. w.p. Mild steel supporting structure. Electric motor driven blower, cycle timer. Audley valves with Audley air motors, instruments, motors, piping, valves, and fittings. New 1952.

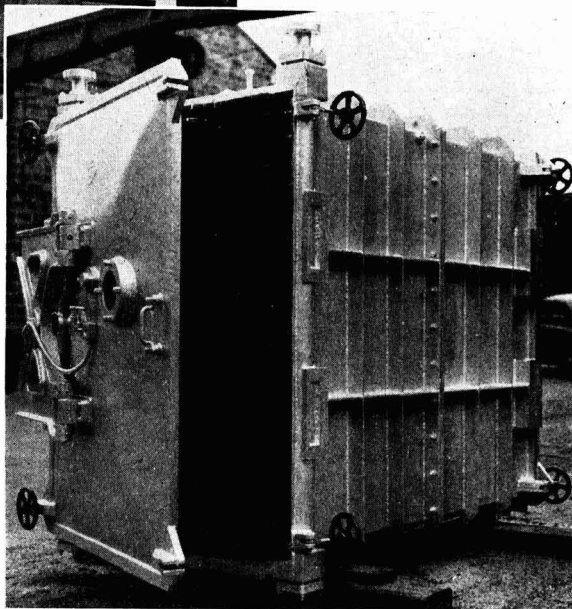

## Several VACUUM OVENS

by FRANCIS SHAW

5 ft. 2 in. wide  $\times$  8 ft. 9 in. deep  $\times$  7 ft. high internally, with 18 platens 1 $\frac{1}{2}$  in. thick giving 3 $\frac{3}{8}$  in. daylight, effective platen width 60 $\frac{1}{2}$  in. Heavy swing door each end with corner wheel operated swing clamps. Flanged connections to internal headers with swan neck connections to platens. Cast iron construction.

# GEORGE COHEN SONS AND COMPANY LIMITED

WOOD LANE, LONDON, W.12. STANNINGLEY, NR. LEEDS

Telephone: Shepherds Bush 2070

Telephone: Pudsey 2241

Telegrams: Omniflant, Telex, London

Telegrams: Coborn, Leeds.

And at Kingsbury (Nr. Tamworth), Manchester, Glasgow, Bath, Swansea, Newcastle-on-Tyne, Belfast, Sheffield, Southampton.



# CLASSIFIED ADVERTISEMENTS

**CLASSIFIED RATES:** All sections 5d. per word. Minimum 8/-. Three or more insertions 4d. per word. Box Number 2/- extra.

**SEMI-DISPLAY:** 30/- per inch. Three or more insertions 25/- per inch.

## PATENTS & TRADE MARKS

**KINGS PATENT AGENCY, LTD.** (B. T. King, A.I.Mech.E., Patent Agent), 146a Queen Victoria Street, London, E.C.4. City 6161. Booklet on request.

## PLANT AND MACHINERY FOR SALE

### PHONE 55298 STAINES

**Stainless Steel**—6 ft. Spherical Still.  
**Stainless Steel** 750 & 500 gall. Air Jacketed Cyl. Enc. Flameproof Mixers A.C.  
**Stainless Steel** 750 gall. Cyl. Tanks.  
**Stainless Steel** 12 ft. Bucket Elevators—21 in. by 16 in. by 10 in. buckets.  
(40) 'Z' & **Fin Blade Mixers** up to 70 in. by 53 in. by 42 in.  
(30) 'U' **Trough Mixers** up to 9 ft. 6 in. by 4 ft. by 4 ft.  
**Double Cone Mixer** 5 ft. by 3 ft. diam. 5 H.P. A.C.  
Filter Press, Pumps, Hydros, Condensers, etc.

*Send for Stock Lists*

**HARRY H. GARDAM & CO. LTD.,**  
100 CHURCH STREET, STAINES

**Baker-Perkins Class BB "Double Naben" Bladed Steam Jacketed Mixers.** Four—size 12 and Three—size 11, of 20 and 8 gallons respectively.

**Oil Jacketed Double Trough Mixer** 48 in. by 36 in. by 29 in. deep. Paddle Blades. Bottom Outlets.

**Barron 'U' Sifter Mixer** 96 in. by 33 in. by 33 in. with 10 H.P. A.C. Motor.

**Gardner 'U' Sifter-Mixers** 66 in. by 24 in. by 24 in. with 5 H.P. A.C. Motors. Four available, of modern streamlined design.

**Horizontal 'U' Trough Mixers** 48 in. by 18 in. by 22 in. Three—Tilting type, Paddle Blades. Glanded.

**Over-Arm Twin-Blade, Tilting, 30 gallon Mixers** with 3 H.P. Geared Motors. Five available.

Lying at our No. 2 Depot, Willow Tree Works, Swallowfield, Berkshire.

Apply: **Winkworth Machinery Limited, 65 High Street, Staines, Middlesex.** Telephone 55951.

**S.S. Jacketed Gas-heated Pan,** 22 in. by 21 in. deep.  
2-sheet Filter; gunmetal; chamber 12 in. by 14 in.  
Two-head **S.S. Vacuum Bottle Filler;** pump and motor.  
"Briton" **LB7 Hammer Mill;** magnet chute, cyclone.  
"Pascal" 6 in. dia. **Pin Disc Mill** on stand.  
"Morton" **Mixer;** double Z-arm, 4 h.p. motor.  
"Gardner" **Sifter/Mixer;** trough 40×20×20.

**WELDING, SAXONE BDGS., TARLETON ST., LIVERPOOL.**

## SITUATIONS VACANT

**CASTROL LIMITED** require a Technical Assistant (Patents) for handling patent applications and allied work. Applicant should preferably be qualified to intermediate C.I.P.A. level and must have had experience in the field of chemical patents. Five day week, pension scheme, salary according to age and experience. Successful applicant will be attached to Research Department at Hayes, Middlesex.

Please write in confidence, giving details of age, qualifications, and experience to:

**Group Laboratory Manager,**  
**Castrol Limited,**  
Clayton Road, Hayes, Middx.

**ANALYST REQUIRED** to take charge of Analytical Laboratory of fine chemical manufacturers. Good prospects, pension scheme and all facilities. Applicants should possess a degree in chemistry and experience in this field. Apply in writing with full details of education and experience to Cocker Chemical Co. Ltd., Oswaldtwistle.

**MCVITIE & PRICE LTD.,**  
BISCUIT MANUFACTURERS,

require a

## QUALIFIED CHEMIST

*for their works at Harlesden, N.W.10.*

Applicants should be not more than 35 years of age and have laboratory and technical experience of Edible Oils and Fats. The appointed candidate would be required to manage the department processing baking fats and would have no responsibility in the laboratory. Salary would be by arrangement, and a contributory pension scheme is in operation. The company is a progressive one and the successful applicant would have opportunity for advancement according to his ability.

*Applications should be sent to The Personnel Officer at the above address.* (1371)

## ASSISTANT CHEMIST

Applications are invited for the above post, which is located at Hinckley Gas Works.

Candidates who should possess the Higher National Certificate in Chemistry, will be responsible for the chemical control of plant. The salary for the appointment, which is pensionable and subject to medical examination, will be within the range of £770—£870 per annum.

Applications, stating age, qualifications and experience, should be addressed to Mr. A. Allen, Divisional General Manager, West Midlands Gas Board, Gas Street, Coventry, to reach him not later than the 26th September 1960.

## SITUATIONS VACANT: continued

Robert Clive (Consultants) Limited, invite applications for the following appointments:

**CHEMICAL ENGINEERS**

A major oil company requires additional Chemical Engineers for its London headquarters. Applicants should be aged under 30 and should have had a few years' process engineering experience. Applications would, however, also be considered from graduates who have recently qualified and preference will be given to those with Honours Degrees. The duties will be concerned with process design, refinery technical services, and pro-

cessing studies. This is an opportunity to join a leading company in an industry of world growth. Initial salary up to £1,500 according to age, experience and qualifications; pension fund: first-rate modern office accommodation and all the other associated amenities. There is also the possibility later of overseas service for those who wish to make their career abroad.

Reference Number 98.

**DESIGN ENGINEERS**

The same company requires Chemical and Mechanical Design Engineers for their Oil Refinery in the Middle East. Applicants should preferably have a Degree in Chemical or Mechanical Engineering and should have had several years' design experience. Familiarity with all or some of the design problems associated with the following would be an advantage: liquid and gas pumping equipment, gas engines, steam turbines, heat exchangers, coolers, steam generators and boilers, piping

systems, high and low pressure units together with the necessary calculations of flows, pressure drops, heat transfer factors, etc. Initial salary not less than £1,600, plus living allowance, free accommodation, paid home and local leaves, passages paid, pension and provident schemes. Scope for advancement to senior positions and the remuneration provided allows for savings to be made to build up capital.

Reference Number 99.

Please reply in confidence, quoting reference number to:—



Robert Clive (Consultants) Limited

Appointment Consultants

27 ALBEMARLE STREET, LONDON, W.1.

**BRADFORD INSTITUTE OF TECHNOLOGY****Head of Department of Chemical Engineering**

Applicants are invited for the Headship of the Department of Chemical Engineering which is to be created in the near future. The Department organises full-time courses for the Diploma in Technology, the B.Sc. (London) degree and qualifications of the Institution of Chemical Engineers. Research is being developed in collaboration with industry. Plans have been approved for a separate new building for Chemical Engineering which will provide excellent facilities for the extension of teaching and experimental work.

Applicants should be well qualified Chemical Engineers with responsible industrial experience, including that of original design. It would be useful to have previous teaching and/or research experience relevant to the development of under-graduate and post-graduate work in collaboration with industry.

The starting salary will accord with the qualifications and experience of the candidate and will be within the range of Grade V or Grade VI of the Burnham Report, i.e. between £2,100—£2,500 per annum. The appointed Head will be permitted to undertake consultant work. Further particulars and forms of application may be obtained from the Registrar, Bradford Institute of Technology, Bradford, 7.

HENRY PATTEN,  
Clerk to the Governors.

**BRITISH HYDROCARBON CHEMICALS LIMITED**

(manufacturers of petroleum chemicals)

requires

**RESEARCH CHEMISTS**

for work in the field of applied chemistry in its research laboratories at Grangemouth, Stirlingshire.

Applicants should be male, between 21 and 25 and have 1st class or good 2nd class degrees in chemistry or applied chemistry.

There is a non-contributory pension scheme. Starting salary will depend upon age and qualifications. The Company is expanding and prospects of advancement are good.

Please apply with full particulars to: Personnel Department, British Hydrocarbon Chemicals Limited, Devonshire House, Mayfair Place, W.1.

**WORK WANTED & OFFERED**

**CRUSHING, GRINDING, MIXING AND DRYING for the trade  
THE CRACK PULVERISING MILLS LTD.**

Plantation House,  
Mincing Lane,  
London, E.C.2

**GRADUATE SCIENTIST** wanted for research on practical problems of gypsum technology. An interest in one or more of the following is desirable. General properties of solids (including powders), applied mechanics, phase transformations, drying. Non-contributory pension scheme. Write: Controller of Research, British Plaster Board (Holdings) Ltd., East Leake, near Loughborough, Leics., quoting AR/1. (1370)

**THE YORKSHIRE TAR DISTILLERS, LTD.**, requires a Qualified CHEMIST with a sound working knowledge of the techniques of Infra-Red Spectroscopy and Gas Liquid Chromatography. The successful applicant, who will be in charge of this section, will be expected to carry out non-routine I.R. and G.L.C. analyses on coal tar derivatives, and also to develop the use of these techniques for works control. The salary paid for the appointment will be commensurate with qualifications and experience. A five-day working week is operated. Applications to Dr. E. C. Holdsworth, The Yorkshire Tar Distillers, Ltd., Stairfoot, Barnsley, Yorkshire.

**The quickest way**

to obtain the services of a chemical  
engineer, chemist, laboratory  
assistant and other fully qualified  
personnel

is through a classified  
advertisement in *Chemical Age*

Full details will be found on page 441-2



# Chemical Age Enquiry Service

For fuller details of equipment, apparatus, chemicals etc., in the advertisement or editorial pages of Chemical Age, fill in the coupons below, ONE PER ENQUIRY, and return to us.

<p><i>Please send further details about</i> .....</p> <p>.....</p> <p>.....</p> <p><i>mentioned on page</i> ..... <i>of this issue.</i></p> <p><i>Name</i> ..... <i>Position</i> .....</p> <p><i>Firm</i> .....</p> <p><i>Address</i> .....</p> <p>.....</p> <p><b>Chemical Age Enquiry Service.</b></p>
<p><i>Please send further details about</i> .....</p> <p>.....</p> <p>.....</p> <p><i>mentioned on page</i> ..... <i>of this issue.</i></p> <p><i>Name</i> ..... <i>Position</i> .....</p> <p><i>Firm</i> .....</p> <p><i>Address</i> .....</p> <p>.....</p> <p><b>Chemical Age Enquiry Service.</b></p>
<p><i>Please send further details about</i> .....</p> <p>.....</p> <p>.....</p> <p><i>mentioned on page</i> ..... <i>of this issue.</i></p> <p><i>Name</i> ..... <i>Position</i> .....</p> <p><i>Firm</i> .....</p> <p><i>Address</i> .....</p> <p>.....</p> <p><b>Chemical Age Enquiry Service.</b></p>

★ *Detach this page complete then fold as marked overleaf to use the post-paid reply folder*

แผนกห้องสมุด กรมวิทยาศาสตร์  
 กระทรวงอุตสาหกรรม

# Chemical Age

## ENQUIRY SERVICE



*☐ This is a special service for readers of*

**CHEMICAL AGE**

*☐ It is designed to give fuller information on equipment, apparatus, chemicals etc., mentioned in this issue—whether in the editorial text or in an advertisement*

*☐ Cut out the whole of this page, fold as instructed with post-paid address on the outside*



**Chemical Age**

154 Fleet Street, London, E.C.4

Tel.: Fleet Street 3212

CUT ALONG THIS DOTTED LINE

Postage  
will be  
paid by  
the  
Licensee

2nd FOLD

No Postage  
Stamp  
necessary if  
posted in  
Great Britain  
or  
Northern Ireland

BUSINESS REPLY FOLDER  
Licence No. 2501

**CHEMICAL AGE**  
**154-160 FLEET STREET**  
**LONDON, E.C.4**

3rd FOLD

1st FOLD



# ACID RESISTING CASTINGS

**TANTIRON** the original and still the best high silicon iron in the world offers a remarkable resistance to the corrosive attack of most acids, alkalis and inorganic salts.

PUMPS, VALVES, PIPELINES, EJECTORS, INJECTORS, AGITATORS, ANODES and many special castings are manufactured to suit many varied applications.

**LENNOX FOUNDRY COMPANY LIMITED**  
TANTIRON FOUNDRY, GLENVILLE GROVE, LONDON SE8



**COMPRESSORS**

**EXHAUSTERS**

**BOOSTERS**

**BLOWERS**

*These Gas Compressors, capacity 400,000 cu. ft. per hour at 15 lbs/sq. inch, are installed at Etruria, Stoke-on-Trent.*

*Photograph by courtesy of West Midlands Gas Board.*

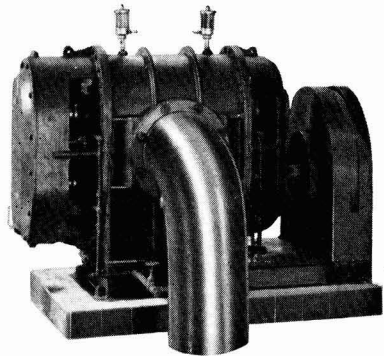

Better built by  
**WALLER**

Problems involving the transmission of air or gas—over long or short distances—at high or low pressures—in large or small quantities—can best be solved by applying more than a century's specialised knowledge and experience such as ours.

**COMPRESSORS** Single or multi stage reciprocating types: pressures up to 5,000 p.s.i.

**EXHAUSTERS** Roots positive type up to 15" H.G. Vacuum.

**BLOWERS** Roots positive type: capacities up to 1.4 million cu. ft. hour: pressures up to 12 p.s.i.

**BOOSTERS** High or low pressures: positive or fan types.

**GEORGE WALLER & SON LTD • PHOENIX IRON WORKS • STROUD • GLOS.**

*Telephone: Brimscombe 2301-2.*

# ULTRASORB ACTIVATED CARBONS

*are available for the recovery of most industrial solvents, benzole extraction, water purification and other gas and liquid phase applications*

Full details will gladly be supplied by

## BRITISH CARBO NORIT UNION LIMITED

**LONDON ROAD, WEST THURROCK, GRAYS, ESSEX**

Cables: 'BRICARBUN GRAYS'

Telephone: GRAYS THURROCK 4845

*CARBO-UNION-WHESSOE Activated Carbon Recovery Plant for the purification of gases and the recovery of vapour phase solvents*

**WHESSOE LTD.** DARLINGTON CO. DURHAM Cables: WHESSOE DARLINGTON Tel: DARLINGTON 68681  
London Office: VICTORIA STREET, S.W.1 Tel: ABBEY 3881

## Compressors for Industrial Gases

Moderate speed compressors carefully designed for reliability, are available in both vertical and horizontal arrangement from small capacities up to units of over 5,000 H.P. and very high pressures.

The illustration shows two vertical, three crank, six stage compressors each with a capacity of 3,000 cu. ft. per minute and a delivery pressure of 326 atmospheres.

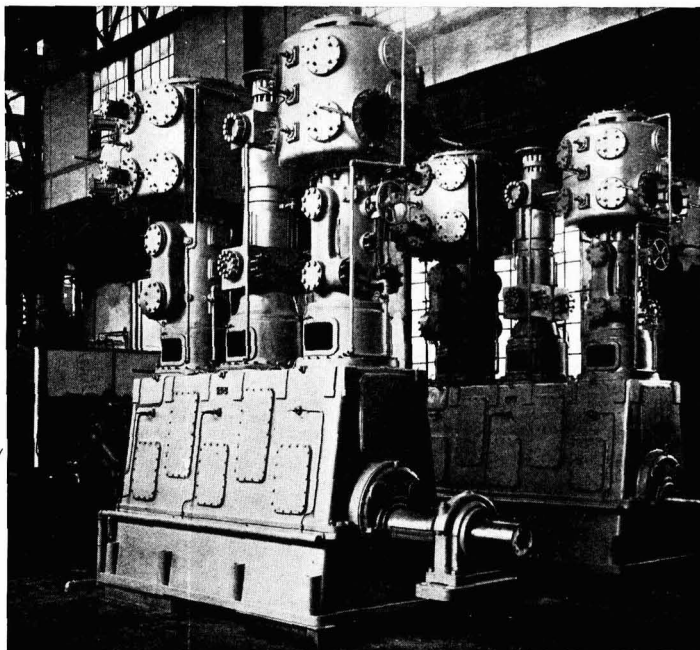

Maschinenfabrik **Esslingen** Germany

**LLOYD & ROSS LTD**

58 VICTORIA STREET S.W.1  
TELEPHONE: VICTORIA 4873