

Chemical Age

PROPERTY OF
THE LIBRARY

11 MAY 1961

USA ACADEMY

incorporating

PETROCHEMICALS and POLYMERS

VOL. 85 No. 2180

22 APRIL 1961

C. 2

APV for the A₂Z of Heat Exchange with chemicals

DBO

EtOH

N-MP

CAL

MEA

PVA

MIBK

APV Rosenblad Spiral Heat Exchanger. Embodying a compact spiral design and made in mild steel, stainless steel, Monel and certain other materials to meet a wide variety of operating conditions. One or more of the three basic types will handle saturated gases, vapours, liquids or sludge. Removable end covers permit easy access to heat exchange passages.

APV Rosenblad Spiral Heat Exchanger Type 1

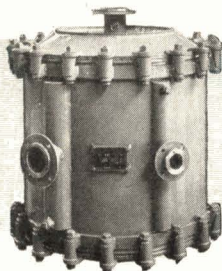

APV Paraflow Plate Heat Exchanger. With fully accessible, easily cleaned contact surfaces of stainless steel, titanium and certain other corrosion-resistant metals, the Paraflow is without equal for handling liquids that are corrosive or require hygienic conditions. Plates may be added or removed and capacity varied. A number of duties can be performed. Available in a range of sizes and frames.

APV Paraflow Plate Heat Exchanger, Type CHF

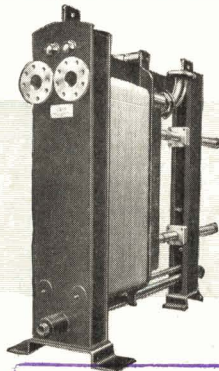

THE A.P.V. COMPANY LIMITED · MANOR ROYAL · CRAWLEY · SUSSEX

TELEPHONE: CRAWLEY 1360 TELEEX: 8737. TELEGRAMS: ANACLASTIC CRAWLEY.

แผนกห้องสมุด กรมวิทยาศาสตร์
กระทรวงอุตสาหกรรม



DE COLOUR ISING

WITH

ACTIBON

SUGARS · FATS & OILS ETC.
MISCELLANEOUS FOOD PRODUCTS
ALCOHOLIC BEVERAGES · ORGANIC
CHEMICALS · BIOCHEMICAL
PREPARATIONS · ENZYMES &
VITAMINS · HORMONES

These are some of the many applications for which ACTIBON — the highly activated decolourising carbon — has been developed.

Please consult us about *your* decolourising problems.

**THE CLYDESDALE
CHEMICAL CO., LTD.**

Sales Office:

142 QUEEN ST., GLASGOW C.I.

Phone: CENTRAL 5247-8

Grams: CACTUS GLASGOW

CROMIL & PIERCY LTD.



GRAPHITE
IN ALL FORMS

MILBURN HOUSE
"E" FLOOR
NEWCASTLE-ON-TYNE
Tel: 2-7761



At your service . . . a fleet of
TANKERS for the **TRANSPORT**

of
**BULK
LIQUIDS
POWDERS**
and
GASES

CROW
CARRYING
CO. LTD.

HARTS LANE, NORTH STREET
BARKING, ESSEX

Telephone: Rippleway 0366
and

231 GREENGATE, MIDDLETON
JUNCTION, MIDDLETON
MANCHESTER

Telephone: Failsworth 3353

PROJECT AND EQUIPMENT ENGINEERING

Complete process plant is designed, supplied and erected for the gas, chemical, petro-chemical and petroleum industries.

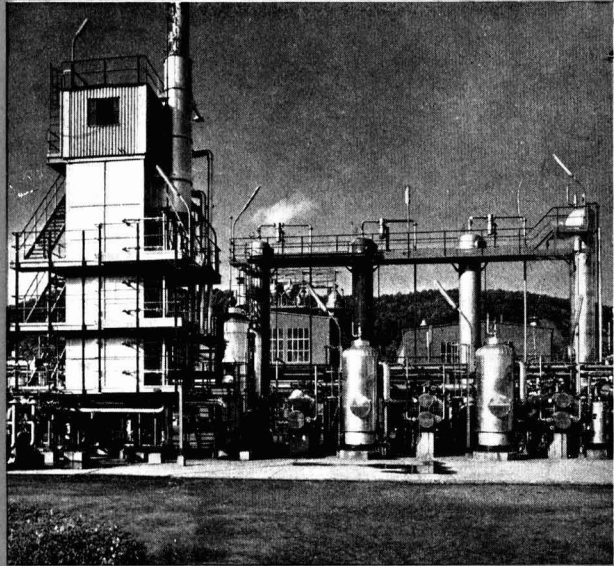

Hydrogen plant producing a high purity hydrogen.

Oil gasification plant with a capacity of 20,000,000 cu. ft. per day of town gas.

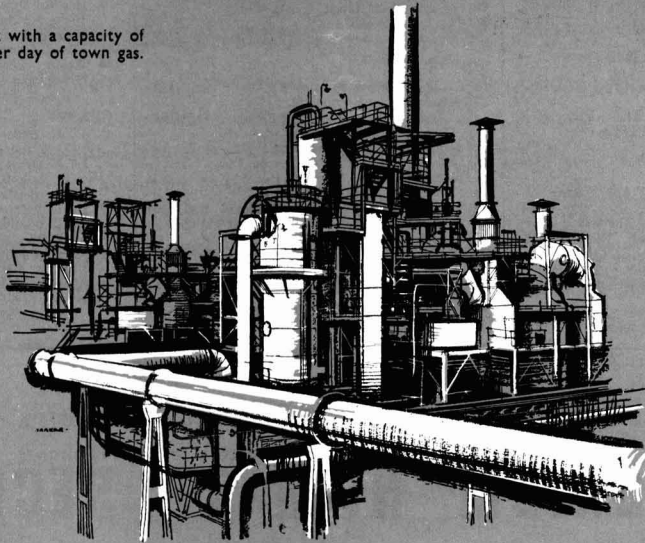

THE POWER-GAS CORPORATION LIMITED

STOCKTON-ON-TEES AND LONDON

DAVY - ASHMORE GROUP

439

PARIS

MONTREAL

MELBOURNE

JOHANNESBURG

BOMBAY

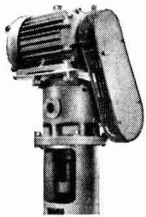
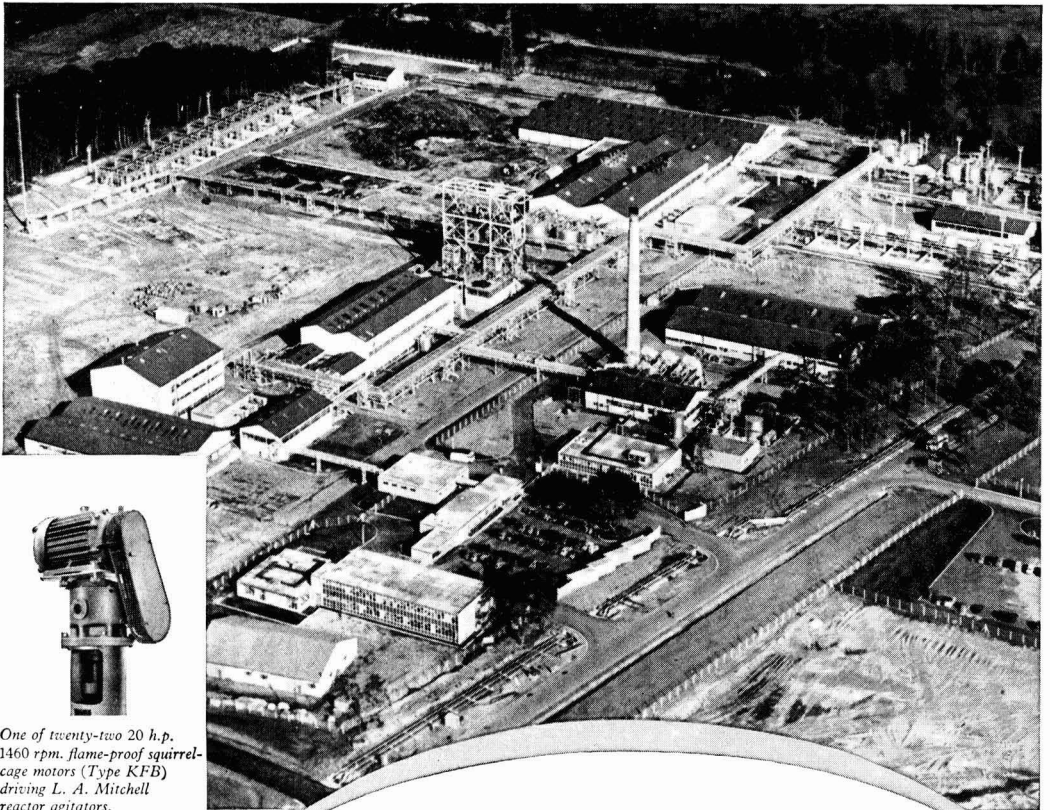

One of twenty-two 20 h.p. 1460 rpm. flame-proof squirrel-cage motors (Type KFB) driving L. A. Mitchell reactor agitators.

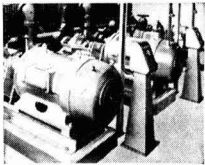

Two of four 100 h.p. 2920 r.p.m. squirrel-cage motors (Type HRSP), with pedestal control stations, driving water pumps.

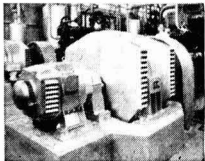

Two of four 425 h.p. 300 rpm. salient pole synchronous motors (Type SM) with overhung exciter driving L. Sterne's refrigeration compressors.

Over 850 AEI Motors for one of the world's most modern synthetic rubber plants

The plant of the International Synthetic Rubber Company Ltd at Hythe is capable of producing 90,000 tons of synthetic rubber a year using butadiene and styrene as the main raw materials. Three grades of rubber are produced suitable for making motor vehicle tyres, coloured rubber products and general products. The motors ranging from 0.25 to 620 h.p. and used for driving pumps and compressors, were all supplied by AEI. In addition, AEI made and erected the switchgear, transformers and other substation equipment for this plant.

AEI

Associated Electrical Industries Limited

MOTOR & CONTROL GEAR DIVISION RUGBY AND MANCHESTER ENGLAND

Visit Stand No. 6, Row N, at the Engineering, Marine Welding & Nuclear Energy Exhibition, National Hall, Olympia, April 20-May 4th.



VERSATILE FUNGICIDE AND BACTERICIDE FOR INDUSTRY—

Whatever your business, you'll find 'TOPANE' the best germicide you can buy. Outstanding in safety and non-toxicity, 'TOPANE' also fills the bill in efficiency and economy. Consider the low concentrations of 'TOPANE' needed to control the growth of these prevalent fungi and bacteria:

Industry	Species of fungi or bacteria prevalent	% for inhibition of growth	Industry	Species of fungi or bacteria prevalent	% for inhibition of growth
Disinfectants	<i>Aerobacter aerogenes</i>	0.032	Adhesives	<i>Bacillus subtilis</i>	0.016
	<i>Bacillus rubricus</i>	0.004		<i>Aspergillus flavus</i>	0.008
	<i>Escherichia coli</i>	0.032		<i>Paecilomyces varioti</i>	0.008
	<i>Pseudomonas caudata</i>	0.032		<i>Penicillium variabile</i>	0.004
	<i>Staphylococcus aureus</i>	0.032	Timber	<i>Ceratocystis pilifera</i>	0.008
	<i>Trichophyton interdigitale</i>	0.008		<i>Coniophora cerebella</i>	0.008
		<i>Merulius lacrymans</i>		0.001	
Textiles and Ropes	<i>Aspergillus niger</i>	0.004	<i>Polystictus versicolor</i>	0.008	
	<i>Chaetomium globosum</i>	0.008	Foods	<i>Alternaria citri</i>	0.008
	<i>Cladosporium herbarum</i>	0.008		<i>Diplodia natalensis</i>	0.010
	<i>Memnoniella echinata</i>	0.004		<i>Penicillium italicum</i>	0.016
	<i>Myrothecium verrucaria</i>	0.002		<i>Rhizopus nigricans</i>	0.016
	<i>Penicillium notatum</i>	0.008			

'TOPANE' (I.C.I.'s brand of ortho phenylphenol) is soluble in organic solvents, and 'TOPANE' WS (I.C.I.'s brand of sodium ortho phenylphenate) is its water-soluble grade. Both products are lethal to many bacteria, fungal spores, surface mildews, and rots, and can be employed to protect organic matter against most forms of microbiological degradation.

'TOPANE' COMBINES EFFICIENCY WITH OUTSTANDING SAFETY

1. DISINFECTANTS



'Topane' is a powerful weapon against infection. It broadens the killing range of disinfectant formulations against both Gram-positive and Gram-negative bacteria, and has low affinity for extraneous organic matter and low toxicity to higher life. 'Topane' is not classified as a poison and its high efficiency plus safety-in-handling recommend it in domestic, veterinary and industrial disinfectants.

2. TEXTILES and ROPES



Rotproofed with 'Topane', textiles and ropes stay strong, last longer. Effective and persistent, easy and economical to use, non-toxic and non-irritant, 'Topane' gives excellent protection against rot caused by bacterial and fungal attack to ropes and fishing-nets, canvases, carpets and felts, rubberised or p.v.c.-coated fabrics and textile finishes.

3. ADHESIVES

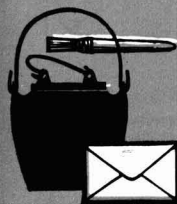

'Topane'-preserved adhesives are fully protected against bacteria and fungi. Incorporated early in the manufacture of the adhesive, 'Topane' ensures the protection of the finished product even after subsequent reconstitution and use. 'Topane' is ideal for the preservation of adhesives incorporating glue and gelatine; starch, dextrin and cellulose; casein; blood and albumin; and latex.

4. TIMBER



Deadly to wood-destroying fungi but non-toxic to humans, 'Topane'-based formulations are safe and economical for treating wet and dry rot in buildings and boats or for preventing sap-stain in freshly sawn timber. Tests carried out on highly resistant fungi show that 'Topane' gives outstanding protection to both soft and hard woods. It may also be used in conjunction with insecticides to give single-treatment timber protection.

5. FOOD STORES

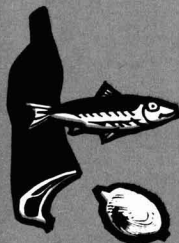

Food stores disinfected with 'Topane' prevent waste and cut losses. Stored food is vulnerable to bacterial and fungal attack; 'Topane' kills food-spoiling bacteria and fungi. Cleaning and disinfecting with 'Topane' helps to keep stored food fresh by eliminating the sources of infection in warehouses, bakeries, breweries, ships' holds and slaughterhouses, and maintains the hygienic conditions essential wherever food products are prepared, stored or transported.

6. YOUR PROBLEM?



We have mentioned some of the major applications of 'Topane' preservatives. There are many more potential uses of 'Topane'. Perhaps, after reading this advertisement, you may think 'Topane' can help you solve a problem in your industry. Let us know about it—we shall be glad to assist you while extending our own knowledge of the applications of 'Topane'.

NAME

COMPANY

ADDRESS

TEL. No.

Please send further information on 'TOPANE' for Application No.

Please arrange for representative to call to discuss 'TOPANE' for Application No.

(If your interest is aroused by Application No. 6, please enclose with this coupon a brief statement of the problem.)

IMPERIAL CHEMICAL INDUSTRIES LIMITED, MILLBANK, LONDON, S.W.1

HT. 1

INSTANTANEOUS JOINTS

*Leakproof.
safe...
reliable!*



For permanent or semi-permanent pipelines 'UNICONE' bolted pipe joints are employed.

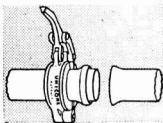

Rubber gasket in position and joint ready to pull over.

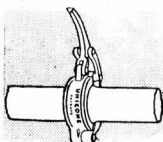

Pipe ends joined ready for locking.

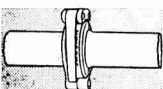

The completed joint.

For temporary pipe lines 'Unicone' instantaneous joints are recommended. Comprising two parts only, they fasten with a "snap" ensuring a perfect seal in a matter of seconds.

For permanent or semi-permanent pipe lines, 'Unicone' bolted type joints are usually employed and can be assembled far more quickly than any other flexible joint giving positive anchorage.

A perfect joint in a matter of seconds...

The 'Unicone' system of pipe-jointing, with its time and labour saving features, produces a pipe line which is flexible while remaining absolutely leak-proof.

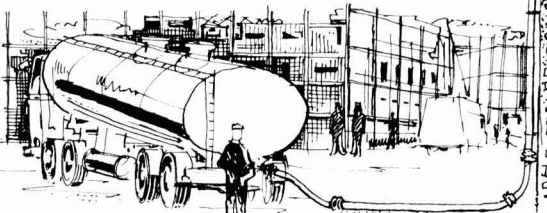

THE UNICONE CO., LIMITED
RUTHERGLEN, GLASGOW, SCOTLAND

▽ G

GLASSBLOWING



Prompt delivery our speciality
OFFICIAL DISTRIBUTORS OF QUICKFIT
and QUARTZ GLASSWARE

We welcome your enquiries
Micro and Semi Micro
apparatus available from stock

**T. W. MCCARTHY
& SON, LTD**

Complete Laboratory Furnishers

30a Clifton Street, Cardiff

Telephone: Cardiff 26251

TURBO-
AGITATORS
TURBO-
EMULSIFIERS
TURBO-
REACTORS
TURBO-
IMPASTERS
TURBO-
CLEAVERS
TURBO-
DISPERSERS
MIXERS OF
ALL TYPES

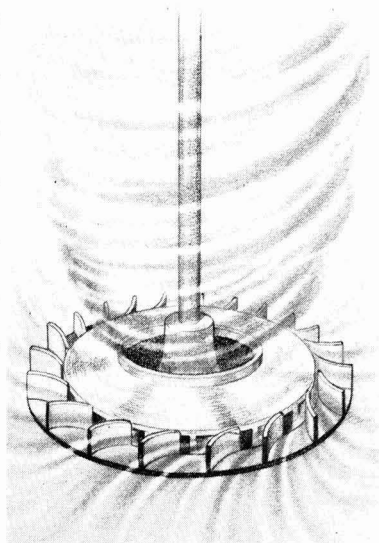

MIX
WITH

MORITZ
CHEMICAL ENGINEERING CO. LTD
204, Earls Court Road, London, S.W.5

LEAFLETS ON REQUEST

"ZULO"



CARBOY HAMPERS

**LEIGH
& SONS
METAL
WORKS**
LTD.
Orlando
St., BOLTON

CARBOYS · PACKED CARBOYS
CARBOY FILTERS AND BARROWS
SAFETY CRATES TOP PROTECTORS



LIQUIDS IN BULK

We are specialists in the bulk transport of the following

ACIDS • CHEMICALS • ALKALIS
 SOLVENTS • CAUSTICS • EMULSIONS
 PETROLEUM • PRODUCTS

Continental Enquiries Welcomed

MONKTON MOTORS LTD.
 WALLINGFORD ROAD, UXBRIDGE, MIDD.

Telephone : UXBRIDGE 35574/5

Kestner stirrers and mixers

Portable Stirrers
 Vortex Stirrers
 Laboratory Mixers
 Continuous Process Mixers
 Side entry stirrers
 with special stuffing box
 able to be repacked with-
 out draining mixing vessel

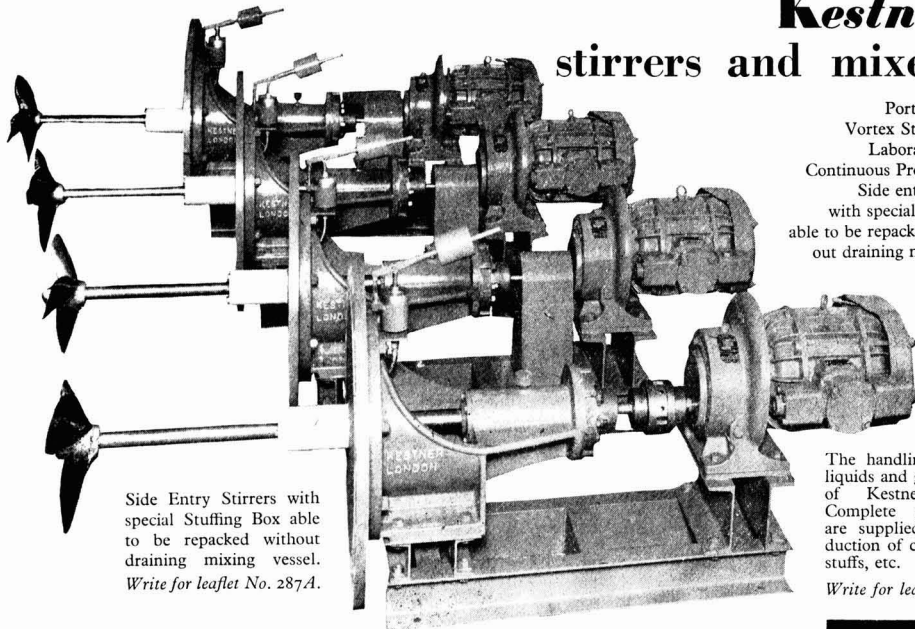

Side Entry Stirrers with
 special Stuffing Box able
 to be repacked without
 draining mixing vessel.
 Write for leaflet No. 287A.

The handling of corrosive
 liquids and gases is but one
 of Kestner's activities.
 Complete process plants
 are supplied for the pro-
 duction of chemicals, food-
 stuffs, etc.

Write for leaflet No. 282/A.



Air separation plant for the Chemical Industry

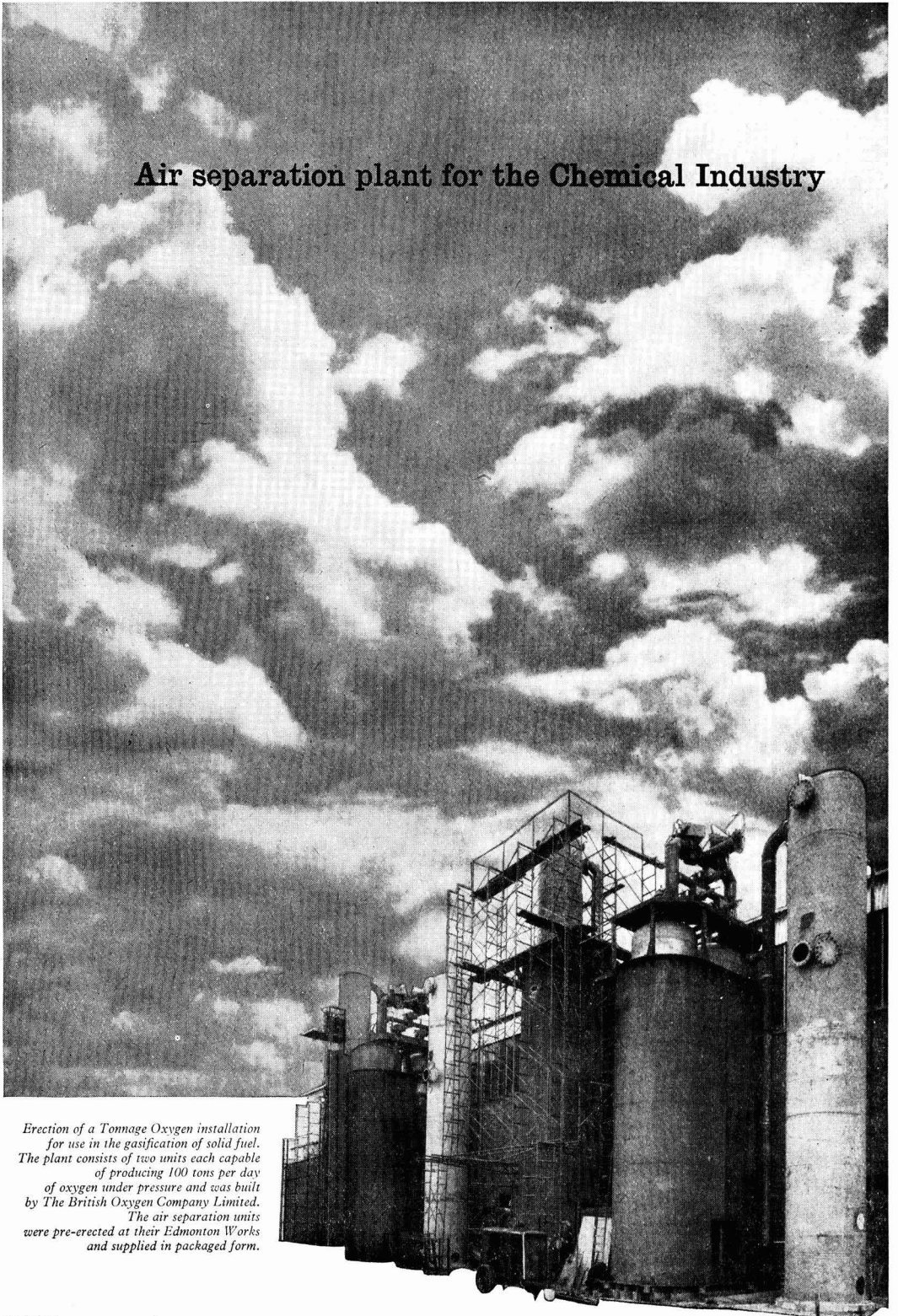

Erection of a Tonnage Oxygen installation for use in the gasification of solid fuel. The plant consists of two units each capable of producing 100 tons per day of oxygen under pressure and was built by The British Oxygen Company Limited. The air separation units were pre-erected at their Edmonton Works and supplied in packaged form.

Tonnage Oxygen and Nitrogen Plant

PLANTS FOR AIR AND GAS SEPARATION

BOC has unrivalled experience in building a wide range of plants specifically designed to meet the diverse requirements of the Chemical, Steel and Gas industries. Continuous bulk demands for atmospheric gases are best met by plant installed close to the point of usage. The consumer can either own and operate such plant or take supplies by pipeline from a BOC installation.

PURIFICATION PLANTS

BOC are specialists in the design and construction of plants for the purification of nitrogen, argon, helium and the rare gases. Very high purity products can be obtained.

ANCILLARY EQUIPMENT

All types of ancillary equipment, associated with air separation plants, are designed and manufactured by BOC. These include a wide range of liquid storage tanks, pumps, evaporators and compressors.

CRYOGENIC ENGINEERING

The specialist skill and knowledge accumulated over many years enables BOC to provide a comprehensive service to all users of atmospheric gases and in cryogenic engineering applications. The benefits of BOC's experience and tradition are free to customers, and experts are always available for discussion and advice—a complete service from pre-sales consultation through all stages of design and construction to after-sales advice and co-operation.

BOC MAKE

Complete Air Separation Installations for Oxygen, Nitrogen and Rare Gases
Transportable Oxygen Plants · Gas Purification Systems
Liquid Oxygen Pumps and Vaporisers · Gas Compressors
Gas and Liquefied Gas Storage Systems · Gas Separation Plants

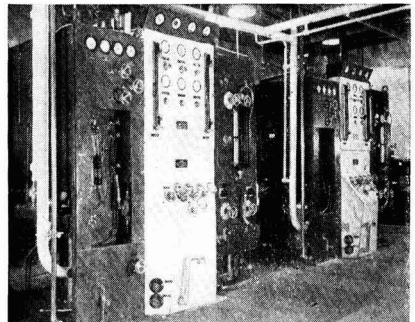

Liquid Oxygen Plants at the Argon Purification Plant, UKAEA, Dounreay

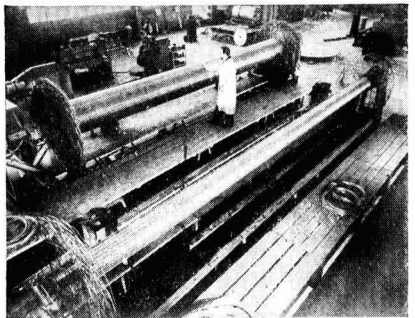

Cross Flow Heat Exchangers

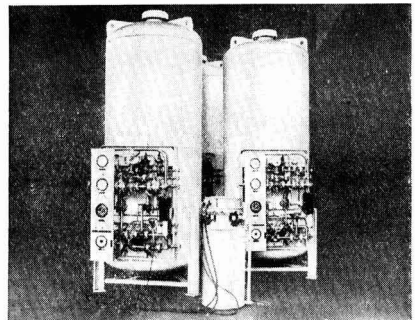

Vacuum Insulated Evaporators

For air separation plant—first consult

The British Oxygen Company Ltd

HEAVY INDUSTRIAL DEPARTMENT Spencer House, St. James's Place, London, SW1. HYD 3051



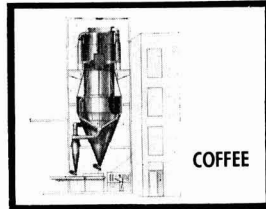
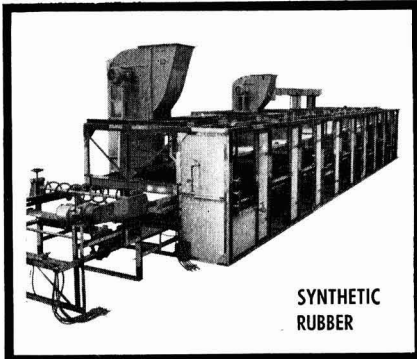
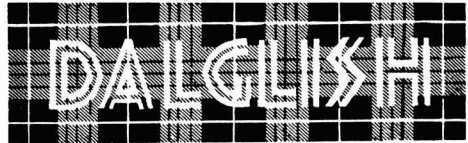

...serving

the world's

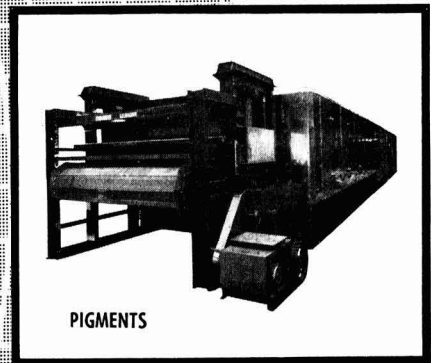

process industries

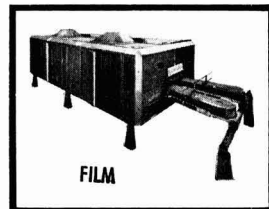
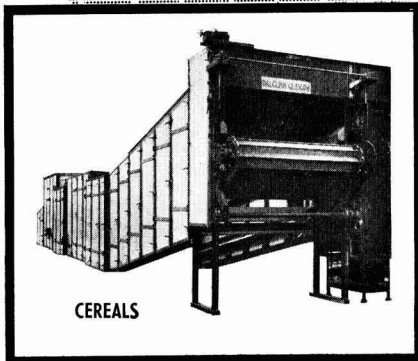

JOHN DALGLISH & SONS LTD

Thornliebank Industrial Estate, GLASGOW

Telephone: GIFFNOCK 2322

Telegrams: 'DALGLISH, GLASGOW'

Telex: 77185

VOL. 85

No 2180

APRIL 22 1961

Telephone: FLEet Street 3212 (26 lines)

Telegrams: Benformula - Cent - London

Editor

M. C. HYDE

Manager

R. C. BENNETT

Director N. B. LIVINGSTONE WALLACE

Midland OfficeDaimler House, Paradise Street,
Birmingham. [Midland 0784-5]**Leeds Office**Permanent House, The Headrow,
Leeds 1. [Leeds 22601]**Scottish Office**116 Hope Street, Glasgow C2.
[Central 3954-5]**IN THIS ISSUE**

Hoechst Annual Report	650
Budget and the Chemical Industry	650
Project News: B.H.C. at Baglan Bay; Monochloroacetic Acid; Polyether Foams	651
Distillates	652
I.C.I. Annual Report	653
Agreement of Effluent Treatment	654
Fisons Start Export Campaign	655
Caprolactam Projects	657
G.L.C. at Elevated Temperatures	658
Commonwealth Mineral Resources	659
Record Year for F. W. Berk	660
Polystyrene Prices Cut	660
Overseas News	661
People in the News	663
Commercial News	666
Trade Notes	668
Diary Dates	668
New Patents	670
Market Reports	670

Annual subscription is: home, 57s 6d, overseas, 65s, single copies 1s 9d (by post 2s)

c

Chemical Age

Incorporating

PETROCHEMICALS and POLYMERS

BOUVERIE HOUSE • 154 FLEET STREET • LONDON • EC4

U.K. WATER PROBLEMS

WITH the approach of warmer weather, bringing with it the possibility of long, dry spells later in the year, and the lesson before us of the 1959 drought which severely affected operations at I.C.I. Billingham, it seems appropriate to reflect a little on the subject of water—a rather prosaic but indisputably necessary material for the chemical industry, not so much as a raw material but as a solvent, a low-cost cooling agent and a source of steam.

In the U.S., industry's fast rising demands for water have been causing concern for some time, and the dry year of 1959, also record-breaking but in the opposite direction to 1960, stimulated more attention to our own piped-water supply problem. Fundamentally, however, there should be no problem for Britain. Last October's rainfall over England and Wales was equivalent to 28,000 million tons. From July to November 1960, 26.85 inches of rain fell, an all-time record for the period since measurements began in 1727—equivalent to nearly 100,000 m. tons.

Even in a dry year it still requires only the catchment of a quite small proportion of total rainfall to meet all expectable demands. In practice there is a somewhat perverse variegation in the supply/demand arrangements of different British areas, and a 'national grid' system is often suggested. But there is an economic difficulty; water distribution costs much more than its catchment and purification, and a truly national grid would undoubtedly mean dearer water. Instead, a policy of co-operation between adjacent water undertakings is being fostered, and to the point of mergers between undertakings.

The Royal Society has recently issued a report on 'hydrological activity' in the U.K. The picture of water research that has emerged from this is remarkably scattered. To liken it to a patchwork quilt would be more apposite if there was much evidence that any single agency was joining the patches together. More than 20 agencies are conducting research on water. Indeed, 20 are Government agencies or Government-sponsored bodies. Different agencies seem often to be making similar or closely similar investigations, though rainfall itself is mainly studied by the Meteorological Office or by workers associated with it. Inevitably perhaps much of the hydrological research seems concerned with data collection; it may not be an unreasonable assumption that the empirical approach to many of water's problems is the most dominant.

There is, no doubt, considerable co-ordination of the many separate research operations through the interested societies and institutions, the Institution of Water Engineers, the Royal Meteorological Society, etc., but the fragmentary pattern of research, though so much of it is State-funded, seems on the face of it open to criticism. Yet to some extent the variety of water's uses and the varied effects its movement as a naturally renewed material can have, provides some explanation for this diversity of research effort.

The amount of water research done, and perhaps its quality as well, depends mainly upon Government expenditure. So long as this total outlay is divided into so many separate ventures, with almost all of them

(Continued on page 650)

HOECHST WITH 1960 PROFITS UP 24% ANNOUNCE NEW GROUP EXPANSION PROJECTS

ON Tuesday this week, Farbwerke Hoechst AG, reported from Frankfurt, a 21.7% rise in turnover last year, profit up by 24.2%, and expansion plans for some of their own plants and for those of subsidiary and associated companies. For the future, Hoechst say they will extend capacities for thermoplastics, monomer vinyl chloride (at the Knap-sack plant), polyvinyl acetate, Trevira fibre, dyestuffs and textile chemicals, chlorine (capacity to rise to 275,000 tonnes/year) and phosphorus (at Knap-sack). Large-scale production of poly-thene waxes is to start this summer.

Turnover last year was valued at DM2,703 million, or £245.7 million. The share of the company in the total chemical turnover of the Federal Republic of Germany thus rose over the year from 7.9% to 11.7%. Turnover increase has continued at a satisfactory level over the first months of the current year, though the same level of increase as last year over 1959 is not expected. Turnover of non-German companies in which Hoechst hold 50% or more, excluding that from deliveries to Hoechst, amounted in 1960 to DM270 million. Of the parent company's turnover, 33% came from export sales. Among German Hoechst holdings, Wacker-Chemie recorded a turnover of DM280 million and Spinnstoffabrik Zehlendorf AG some DM60 million.

Profit and Dividend

Hoechst profit for 1960 was DM107,280,000, or about £9.7 million (DM86,160,000 or £7.8 million). Shareholders on 16 May will be asked to approve a 1960 dividend of 18% (16%).

The company's board, which has decided to increase the Hoechst capital by DM7 million from DM693 million to DM700 million, will also ask shareholders for permission to increase the capital further to DM100 million by May 1, 1966. In 1960 Hoechst spent a total of DM422 million on works installations, of which DM209 million was covered by depreciation. The 1960 investment level is expected to be held in the current year. A total of DM61 million was fed to foreign undertakings last year. Research costs amounted to DM113 million, or 4.2% (4.5%) of turnover. This latter sum excludes DM24 million for research installations included under 'investments'.

In various branches of production Hoechst report the following results for 1960: *Inorganics*—demand continues firm for all products, particularly for phosphorus products and carbon electrodes; *Fertilisers*—heavy price pressure continues; *Dyestuffs*—good standard of business continues; *Pharmaceutical*—business

satisfactory; *Aliphatic chemicals*—new basis formed for supply of raw materials and supply guaranteed over a long period by planned co-operation with oil processing plants.

Hoechst state that turnover of Wacker-Chemie GmbH rose in 1960 by 19.5%, while silicone production developed well as a recent introduction to Wacker's programme. Ruhr-Chemie AG, now owned 33% (formerly 25%) by Hoechst, have developed their new poly-

thene plant satisfactorily, while the oxochemicals plant was considerably expanded and a pilot plant unit for non-foaming detergents was brought into operation. Casella Farbwerke Mainkur AG report a rise in sales of dyestuffs and textile chemicals. Abietta-Chemie GmbH, producers of special chemicals for synthetic rubber production, owned jointly with Hercules Powder, U.S., had a satisfactory year, while Bunawerke Hüls GmbH, synthetic rubber producers, in whom Hoechst have a 16% stake, developed well and are to expand capacity to 120,000 annual tonnes; Turnover of Süddeutsche Kalkstickstoff-Werke AG rose considerably; while that of Spinnstoffabrik Zehlendorf AG increased and is expected to rise further in 1961; Hoechst Chemical Corporation U.S., and Fongra Produtos Quimicos S.A., Brazil, report expanded outputs.

Budget Query is Whether New Duty Will Apply to Oil for Synthesis Gas

THE chemical industry is likely to greet the Budget with mixed feelings, writes our Lobby correspondent—with pleasure that it should contain new ideas for regulating the nation's economy and for the much needed incentive given to younger executives by raising the surtax level to some £5,000, but with disappointment at other provisions.

Hopes that the Budget might give positive encouragement to investment in new plant and to export-minded companies proved to be vain. Industry will have to bear most of the Budget burden—the new payroll tax, the increase in profits tax and the hydrocarbon duties. The payroll tax—if ever applied for a whole year—would cost the chemical industry more than £4 million; the 2½% rise in profits tax will raise direct tax on profits to nearly 54%; while the extra 2d/gall. on fuel oil, gas oil and kerosene would cost chemical manufacturers more than £2 million in a full year.

At the time of going to press, it was not known whether the major oil companies would pass on the extra 2d/gall., or whether in view of their current drive to boost consumption they would absorb part or all of it.

Nor has it so far been made clear by official Government sources whether the oil tax will apply purely to oil for fuel or whether certain types of oil used for synthesis will also be affected. The general impression is that synthesis oil will not be affected, but the tar distilling industry fears that the tax may be applied to such tar products as naphthalene and anthracene. If duty were applied to these products it would add substantially to the cost of using them for synthesis. It is understood that a meeting of representatives of the Association of Tar Distillers with Customs and Excise and other appropriate Government officials will take place during the coming week.

Another effect of the Budget proposals will be that the chemical industry will have to bear its share of increased road

transport brought about by raising the licence fee by £2 10s a year.

On the credit side, firms investing abroad will now be able to claim double tax relief on local as well as national taxes paid abroad. A further concession concerns newly acquired sources of overseas income; there will also be an effective tax inducement to British investment in under-developed countries.

'Chancellor Has Strange Idea of Industry'—Sir Miles Thomas

ASKED by CHEMICAL AGE to comment on the Budget proposals, Sir Miles Thomas, chairman of Monsanto Chemicals Ltd., said "Surtax adjustment will encourage our young scientists and engineers to increase their earning power, but I don't like the idea of variable duty and purchase tax. Industry needs stability to plan ahead. If Whitehall tries to regulate the economic temperature by raising and lowering tax and duty like a flame under a frying pan, it may succeed only in burning its fingers while tipping industry out of the frying pan into the fire.

"As for the payroll tax, the Chancellor has a strange idea of industry if he thinks that employers, particularly in the chemical industry, pad their payrolls just for fun. And unions are hardly likely to approve arbitrarily increased production costs without corresponding benefits to the labour force."

U.K. Water Problems

(Continued from page 649)

sideline activities of different agencies of funds will tend to be small, the separate results of budgetary cuts under different Ministries, battles with other demands. A single unifying agency would be far more likely to get fuller financial support and probably could also use it to better total effect.

Project News

B.H.C. Announce S. Wales Plants, Have Others in Planning Stage

FURTHER details of their plans for the development of their new Baglan Bay, South Wales, site have been released by **British Hydrocarbon Chemicals Ltd.** It was announced in *CHEMICAL AGE* last week (p. 616) that Stone and Webster Engineering Ltd. have been awarded the contract for the ethylene and butadiene plants; the contract for an ethylene dichloride plant has been awarded to the Lummus Co. Ltd. Lummus have also been responsible for the ethylene dichloride plant now nearing completion at B.H.C.'s Grangemouth works, of which the Baglan Bay unit will be a duplicate. The Baglan Bay site, between Port Talbot and Neath, comprises several hundred acres and so far some 100 acres of sand dunes have been cleared and levelled for initial development. Following the Grangemouth pattern, the initial operations at the Baglan Bay Works will be based on a steam cracker, producing the olefins, ethylene, propylene and butadiene from the resultant mixture of cracked gases. Further products are in the planning stage. As feedstock, the plant will use a light petroleum distillate received from the B.P. Refinery at Llan-darcy, some three miles distant.

Part of the ethylene will be transferred to another B.H.C. plant on the same site where it will be combined with chlorine (to be purchased from another source) to make ethylene dichloride, an intermediate used for the manufacture of vinyl chloride monomer, which in turn is polymerised to p.v.c.

The remainder of the ethylene produced will be transferred to the new plant for the manufacture of styrene monomer which is being erected on the same site by Forth Chemicals Ltd. Butadiene will be extracted and refined for sale, supplementing B.H.C.'s production of butadiene at Grangemouth where one extraction plant has been in operation since 1956 and a second is due to be completed later this year.

In addition to these plants, B.H.C. are constructing facilities for steam generation, water cooling, distribution of electric power (which will be purchased from the South Wales Electricity Board), and product handling and storage, as well as workshops, stores, laboratories, offices, canteen, access roads and rail sidings.

It is planned to bring the Works into operation about the last quarter of 1962. Initially, it is expected to give direct employment to about 400 personnel.

Microcell Enter Polyether Field with 16,000 T.P.A. Unit

● LATEST entrants to the U.K. polyether foam field, **Microcell Ltd.**, the largest member of the B.T.R. group, expect U.K. polyether foam production

to reach 20,000 tons this year, from 15,000 tons in 1960 and 8,000 tons in 1959. Next month Microcell will launch their Crestafoam, which is to be made at a new plant at Silvertown that will use the latest electronic metering and control devices. The unit can develop an output of 16,000 tons/year.

The U.S. sales pattern has followed the same trend as in the U.K., doubling each year since introduced commercially in 1956. Last year, 11 U.S. companies produced and sold around 50,000 tons of polyurethane foams. These sales are attributed to heavy stress on technical service and laboratory work. Microcell, supported by the large B.T.R. group resources, have adopted the same approach to the U.K. market. It is expected that the introduction of intricately moulded shapes of high quality will lead to very large additional demand; this question of moulding will be in the forefront of Microcell's development programme.

B.T.R. were founded in 1924 as the British offshoot of B. F. Goodrich and although B.T.R. are now entirely independent of Goodrich, a valuable technical association is still maintained.

C. J. B. to Handle Bexford Extensions

● EXTENSIONS to the Manningtree, Essex, works of **Bexford Ltd.**, where plastics photographic film base is produced, have been entrusted to **Constructors John Brown Ltd.**, who will be responsible for the design and supervision of the project. Heading the C.J.B. team will be Mr. W. A. Clements as project manager and Mr. C. W. Barnett as project engineer.

Bexford Ltd. are linked with BX Plastics Ltd. and, through them, with the Distillers Co. Ltd. Bexford are also related to Ilford Ltd.

Courtaulds to Produce Monochloroacetic Acid

● PLANS to manufacture monochloroacetic acid and sodium monochloroacetate in a plant to be located at the Spondon factory of their subsidiary, **British Celanese Ltd.**, have been announced by **Courtaulds Ltd.** Cost and capacity of the plant are not revealed, but it is expected that it will be able to meet foreseeable U.K. requirements of both chemicals and enable the company to enter export markets. Courtaulds anticipate that supplies will be available early in 1962. The plant will utilise a continuous process capable of giving high yields. No contractors have so far been named in connection with the project.

Monochloroacetic acid and sodium

monochloroacetate—used in hormone weed killers and for detergents, pharmaceuticals, dyestuffs and photographic and other materials—are not at present made in the U.K., although a number of companies supply imported quantities. Courtaulds have also previously imported the two chemicals for use in their processes—for instance, monochloroacetic acid is used at Spondon to produce cellulose ethers by the reaction with alkali cellulose. Both the main raw materials for monochloroacetic acid production, acetic acid and chlorine, are produced by Courtaulds.

New Use for Expanded Polystyrene

● FIRST in the field with a new use for expanded polystyrene is a Scottish firm, **William Thyne (Plastics) Ltd.**, Edinburgh, who are to build a £55,000 factory for the production of disposable drinking cups. The company will be the only one in the U.K. to make disposable drinking cups of expanded polystyrene, which will be made under licence granted by the Crown Machine and Tool Co., Texas.

As well as making cups, William Thyne will make moulded packaging materials. The company feel that the application and use of expanded polystyrene is still in its infancy and that the growth prospects are considerable.

Ferranti Computer for I.C.I.A.N.Z. in Melbourne

● AN electronic digital computer installation, to cost about £A40,000, has been ordered by **Imperial Chemical Industries of Australia and New Zealand Ltd.** for their central research laboratory in Melbourne, where it will be used for scientific and technical calculations and for the study of various problems connected with the chemical industry in Australia.

The computer, to be supplied by **Ferranti Ltd.**, is the desk-sized Sirius, the overall capacity of which, to meet I.C.I.A.N.Z.'s special needs, will be substantially increased by additional storage and extra facilities for rapid input and output of information. The machine is expected to be installed during the first quarter of 1962, installation being carried out by engineers from Ferranti's Melbourne centre.

Esso Place Contracts for Oil Storage Tanks

● CONTRACT for the supply and construction of 24 floating and fixed roof oil storage tanks for the new Esso petroleum terminal at Tynemouth has been awarded to **Redhough Iron and Steel Co., Gateshead.** The work, valued at approximately £170,000, is expected to take some six months to complete.

Redhough Iron and Steel have also been awarded a contract for the 15 floating and fixed roof tanks for the British Petroleum Co. aromatic project at Kent refinery.

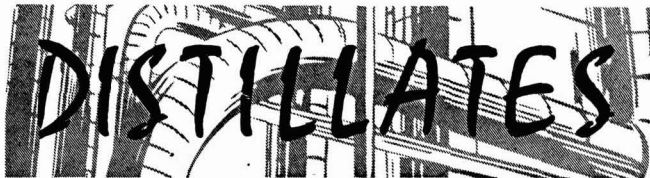

★ A DISAPPOINTING second half of 1960 did not prevent I.C.I. from reporting record profits; but for the effect of price cuts and wage and salary increases, they would have been even higher. However, they follow the pattern of other U.K. chemical companies—better than in 1959, but not as good as the first half of the year might have suggested.

This general experience puts U.K. chemical companies mid-way between their counterparts in the U.S. and West Germany. Across the Atlantic, profits were generally down in 1960; in West Germany profit rises of more than 20 per cent have been reported by two of the 'giants'—Farbenfabriken Bayer and Farbwerke Hoechst. Last week this journal carried the results of Bayer, this week Hoechst results were released as we went to press and are summarised in p. 650.

To mix my metaphors, it is not all roses in the German beer garden. Although Bayer stated they are to raise output of fibres, rubber, pesticides, etc., the board would not tell my German correspondent what the final capacities would be, although it appears that much of the extra production is due for export. Despite the capacity build-up for Perlon and Dralon, Bayer do not seem too confident about the future of the fibres market. This lack of optimism is due to rising competition, linked with the recent revaluation of the mark. Neither are Bayer too happy about the introduction of their shares to the London Stock Exchange.

★ READERS can expect a major announcement from Fisons within the next three months. It will involve large-scale investment, but beyond that, Mr. Wormald, joint managing director, would not go when questioned in London last week. Now that Fisons have decided that take-over prices for other chemical companies are unreasonable they can be expected to invest more heavily within the group.

Playing a prominent part in Fisons' future plans will be their new company—Fisons Overseas Ltd. This has been formed with the specific task of boosting chemical business overseas. Apart from raising direct exports, it will involve the setting up of overseas plant and licensing for overseas manufacture. Shareholders can expect a good return for their money, because the policy will be to develop the sale of research-based products and Mr. Wormald tells me that Fisons' research spending represents between 6 and 7% of chemical turnover—well above the national average.

Mr. Wormald's appointment as chair-

man of the new company is evidence of the importance attached to this venture. Group executive responsible for chemical interests, he speaks many languages fluently, including Russian. Mr. Wormald, who will visit the British Trade Fair in Moscow, with Sir Clavering Fison, will have as deputy chairman, Mr. A. Robinson, chairman of Whiffen and a director of the new Fisons-Constructors John Brown company, Wycon Services. Mr. Robinson is currently on a joint Board of Trade—Federation of British Industries export mission to South-east Asia.

★ MONTECATINI, Italy's biggest and fastest-growing chemical combine, herald the Royal visit to Italy next month with news that they have developed three new synthetic rubbers. From the Milan Trade Fair, my Italian correspondent tells me that these have been the talking point of the 13,900 exhibiting firms and the thousands of visitors. All due to Professor G. Natta's work on stereospecific polymers, they are to be sold as Elaprim, Dutral and Astyr. They will be produced at the new Montecatini petrochemical complex now being built at Brindisi, where the first plants will go into production before the middle of 1962.

Elaprim, a copolymer of acrylonitrile and butadiene has a high resistance to all oils and aliphatic hydrocarbons; it is designed for uses in which rubber is in contact with oils and solvents. For Dutral, a butadiene-propylene copolymer, an exceptional life is claimed; it is also said to be very resistant to heat, ozone, oxygen and all mineral agents, as well as to have the advantage of low cost. Its resistance to acids and ozone is said to equal that of natural rubber and to be superior to that of all other synthetic rubbers.

Astyr, which is Montecatini's 1,4-*cis* polybutadiene, is aimed at replacing natural rubber in tyres, particularly those for heavy duty. Flexibility and elasticity after vulcanising are said to be better than those of the usual natural rubber compounds.

★ AT an 'office-warming party' held last week to mark the opening of larger offices at Mellin House, Hallam Street, London W.1, by Roger Williams Technical and Economic Services Inc., the chairman, Mr. Roger Williams, told me something of the greatly increased activity of this branch of his international consulting firm.

Although chemical market research is

still far from being universally accepted in Europe in the way it has become established in the U.S., it is increasingly being looked upon as a valuable management tool. But as Mr. Williams said, market research is not a job for the 'desk-bound' executive. In the past three months alone, it has involved some 200 personal field interviews in about 27 cities in the U.K. and on the Continent, plus hundreds more in the U.S. and Canada.

This tends to put a high price tag on chemical market research (I hesitate to use the initials C.M.R. in case readers think I have dreamed up a new analytical tool—chemico-magnetic resonance), but there is no short-cut or cheap way of giving management the means of making better decisions on expansion plans, sales promotion and investment.

★ CHEMICAL element, No. 103, which is believed to have decayed out of existence very soon after the birth of the universe, has been produced by a team of workers at the University of California. It is believed that the synthesis was achieved by the bombardment of californium—element 98—with the nuclei of boron 10 or boron 11 in a heavy ion linear accelerator.

Eleven new elements have been produced, 10 of them at the University of California, beyond the 92 which originally made up the periodic table.

The new element will be called lawrencium since the work was conducted in the Lawrence radiation laboratory.

★ ALTHOUGH Soviet scientists have won the *Homo Sapiens* space stakes, the race is far from over. The U.S. space researchers will doubtless strive to be the first to take man to the moon. The Russians have the edge, not only on account of their latest achievement, but also because all of their developments have been with heavier space wagons and with rockets developing greater thrust than those of the U.S.

This week, however, the U.S. Senate Space Committee will study a claim made by the Thiokol Chemical Corporation that by the end of 1961 they can produce a rocket engine with a thrust of some 1.2 million lb.—about one and a half times the thrust of the rocket that put 'Columbus' Gagarin into space last week.

The U.S. space budget has been increased by some £44.6 million, about half the amount sought and it does not authorise any speed-up for the Apollo project, a plan for taking three astronauts to the moon.

Alembic

I.C.I. Annual Report

Home Sales Maintained at High Level with Fertiliser Records Topped in Autumn

EMPHASIS of I.C.I.'s capital programme is now changing from expenditure aimed at increasing capacity by comparatively low-cost modifications to existing plants, to expenditure on the construction of new and bigger plants. This is stated in the annual report of Imperial Chemical Industries Ltd., published on Friday, 21 April. As a result the company's capital spending will return to the higher levels ruling before 1958.

As stated in CHEMICAL AGE, 1 April, p. 540, I.C.I. group income rose 20% over the year, but the second half of 1960 saw profit margins harden. With manufacturing and trading profits up 17% for the group and 18% for the company, the high level of output reached in the early months was in general maintained throughout the year. But the report states that reductions in selling prices and higher wages and salaries resulted in a lower rate of operating profit in the latter half of the year. Of the group net income of £47,572,000, £27,600,000 or more than 70%, was contributed in the period January to June.

"No Adequate Return"

The year's results were a record, but the report states "they gave no adequate return on the volume of capital invested". Mr. S. P. Chambers, chairman, is expected to comment on trends during the first few months of 1961 at the annual meeting to be held at Wigmore Hall, London, on 18 May.

Financial results were given in C.A., 1 April, with separate figures of 1959 and first and second halves of 1960.

Highlights of the report, summarised here, were the maintenance of home sales demand at a high level throughout 1960; record fertiliser sales despite bad farming weather in the autumn of 1960; a 10% rise in exports to a record level and a shift of emphasis from exports to Commonwealth, which were lower, to big increases in trade in newer products to Europe; an £800,000 rise in research spending.

Capital Spending. Expenditure on U.K. construction last year totalled £34 million (£32 million in 1959 and £45 million in 1958). Nearly £40 million of new capital spending was sanctioned during 1960, compared with £22 million in 1959; at the end of 1960 the amount of outstanding capital expenditure sanctioned but not spent was £45 million.

Major new plant brought on stream last year was for polypropylene and acrylonitrile. New plants for polyester fibre, nylon polymer, polyurethane chemi-

cals and Melinex film are expected to come into operation this year. Among large projects approved during the year were plants for the production of nylon, chlorine, polypropylene filament yarn and various petrochemicals and plastics; I.C.I. also announced plans to make caprolactam and to build a Terylene spinning plant in Northern Ireland.

Home Trade. Home market sales were a record and were 9% up on 1959; volume was up 11%. As a result of further price cuts, home prices fell by 2% overall, equivalent to a reduction of about £5 million in income. Demand for I.C.I. products followed broadly the trend of industrial output, reaching a high level early in the year and maintaining that level, with little change to the year end.

Nearly all divisions shared in the increased business; sales of Terylene polyester fibre advanced significantly and a promising start was made with Crimpylene, a new bulked yarn made from Terylene. All plants of Heavy Organic Chemicals Division operated at high rates of output. Notable sales increases were recorded for plasticiser alcohols, butadiene and other intermediates for plastics, paints and resins.

Heavy Organics

Demand for heavy inorganics was well maintained throughout 1960. Considerable increases were noted for chlorine, hydrochloric acid, chlorinated solvents and fluorocarbons—the latter for the fast-growing aerosol market. Chlorine capacity was substantially boosted and plants for the production of chlorinated paraffin wax, chlorobenzenes and chloromethanes were extended.

Record quantities of fertilisers were used in 1959-60, and although the wet autumn of 1960 was a handicap to British farmers, I.C.I. fertiliser sales showed a further rise. New plants were opened at Billingham and Heysham for C.C.F., Nitro-Chalk and Kavnitro.

Home market sales in 1960 were divided between the main consuming industries as follows:

	£m.	% of total
Agriculture	53.7	18
Textiles	47.0	15
Engineering	32.0	10
Chemicals	26.4	9
Motor & aircraft	18.3	6
Building trades	15.3	5
Plastics	14.3	5
Mineral oil refining	8.8	3
Mines & quarries	8.4	3
Government Departments & public authorities	6.1	2
Glass & ceramics	5.4	2
Paper & paperboard	4.8	2
All other (inc. chemical merchants)	62.6	20

Exports. Exports amounted to a record £96.6 million f.o.b., 10% up on 1959. As

a result of manufacture overseas, sales outside the U.K. of chemicals produced by I.C.I. overseas subsidiaries are now about equal to the overseas sales of products made in the U.K. The group's total overseas sales of £255 million now approach in value total group home sales.

The past 10 years have seen a four-fold rise in exports of newer and more sophisticated products—the main reason for the doubling of total I.C.I. exports in that period. In 1960, plastics, dyes and Terylene accounted for nearly half of the year's exports. Compared with 1959, sales of the newer heavy organics rose 53% and those of pharmaceuticals were up 23%.

Exports to Europe

These newer products are sold mainly to Europe; exports to the European Free Trade Association, which takes a big part of Terylene exports, rose 23%, while exports to the Common Market were up 26%. For the second year running, sales to the U.S.S.R. almost doubled and that country with the rest of East Europe, although still taking less than 6% of the company's total exports is an increasingly important market.

	1958	1959	1960
	F.o.b. value in £ million		
Commonwealth	33.4	36.8	36.2
India, Pakistan, Ceylon	8.8	11.6	10.5
Africa	6.8*	8.9	9.7
Australasia	8.8	7.4	8.3
Canada	1.9	2.0	1.9
Common Market	8.8	11.0	13.9
E.F.T.A. ('Seven')	8.0	11.3	14.0
U.S.S.R. & E. Europe	1.9	3.4	5.5
Rest of Europe	4.6	6.1	6.8
U.S.	3.0	3.9	4.0
Central & S. America	6.3	6.5	6.7
Rest of World	7.8	8.5	9.5
	73.8	87.5	96.6

* South, West & Central Africa.

Research and Development. Spending on research and development, including technical service, amounted to £15 million last year, compared with £14.2 million in 1959, when research took £9.3 million and development £5.7 million. As a result of I.C.I.'s extensive research on synthesis gas (the raw material for ammonia and methanol), a process based on light petroleum distillate, which is much more economical than the coke-based process, is being introduced on a commercial scale. First application will be at Heysham in connection with a project to boost methanol production by a further 45,000 tons/year.

A process for strengthening Melinex film by two-way stretching has now been developed to the commercial stage. The same technique can be applied to polypropylene film and trial quantities have already been distributed. I.C.I. (Hyde)

Ltd. have a new material made of hard p.v.c. in the form of foil for lamination to metal and other materials—this is known as Novon Ten and Vynalast.

A plant for making vinylidene chloride copolymers for surface coating applications will shortly start production. The search for improved Procion dyes continues and the use of the reactive dye principle is being extended to fibres other than cottons and viscose textiles.

Personnel. At the end of 1960, I.C.I. employees in the U.K. numbered 113,699 (109,596). Time lost in the last five years on account of industrial disputes, as a percentage of time worked, was 0.01%, compared with the national average for manufacturing industry of 0.14%. Last year, I.C.I. recruited more than 400 people for training as young managerial staff, a marked increase but less than was wanted. Of the total managerial staff of 8,500, 70% of those under 45 years of age have university degrees, compared with 34% of those aged 45 and over.

Overseas. African Explosives and Chemical Industries (50% held by I.C.I.) had increased sales and a new 110,000 tons/year urea plant came on stream. For the second year, sales by I.C.I. (Export) in West Africa rose by £1 million to more than £3 million. The Tema works were expanded to meet demand for the pesticide Gammalin 20.

Sales and profits of Canadian Industries Ltd. were slightly higher and exports rose, particularly of Terylene and polythene. Plants for polythene film and caustic potash came on stream. Fiber Industries Inc., owned by I.C.I. and Celanese of America to make polyester fibre, completed a plant for staple fibre; another for filament yarn should be in production early in 1961. Duperial Argen-

tina will have plants for sulphuric acid, carbon disulphide, hydrogen peroxide and phthalic anhydride on stream early in 1962; polythene and polyester fibre will be made on the same site at San Lorenzo. Electroclor S.A., a Duperial associate, will raise p.v.c. capacity from 3,000 to 4,500 tons/year.

Sales of I.C.I. of Australia and New Zealand and subsidiaries rose by £A3

Where the Money Went

	1959	1960
	£ million	
Manufacturing & trading proceeds, investment income, etc. ...	515.4	568.9
Raw materials, purchases for re-sale, external services ...	279.9	302.6
Wages, salaries ...	114.6	124.0
Pensions ...	7.6	8.4
Depreciation ...	33.1	37.2
Profit-sharing bonus ...	7.1	8.6
Tax ...	31.5	40.5
Retained in business ...	21.7	23.9
Dividends ...	19.9	23.7
	515.4	568.9

million to a new record of £A63 million. The Osborne alkali plant and the Botany trichlorethylene plant are being expanded and pigments will be made near Melbourne.

I.C.I.'s European Council will have a major petrochemicals site near Rotterdam, while Danbritkem A/S, half owned by I.C.I., should be in production with 15,000 tons/year polythene in 1962.

Substantial sales by I.C.I. (India) of products made by subsidiary and associated companies more than balanced the fall in I.C.I.'s own exports to India. At Rishra, Alkali and Chemical substantially increased the production of paint, chlorine and chlorine derivatives. Plans are in hand to extend the polythene plant. Atic Industries, who make vat dyestuffs, will now also produce the relevant intermediates.

I.C.I. and Head Wrightson Processes Pool Know-how on Effluent Treatment

ANOTHER two companies have arranged to pool their knowledge on the treatment of effluents. They are Head Wrightson Processes Ltd. and the Alfloc Water Treatment Service of I.C.I. By the arrangement, the two firms will collaborate in the assessment and solution of problems relating to treatment of trade and other wastes before discharge to sewers and water courses. In addition, a special study will be made of the re-use of water in industry with a view to alleviating the problems of water supply and the disposal of wastes.

For many years Alfloc Water Treatment Service has specialised in the treatment of water of types, including that grossly polluted, for the needs of industry. The information and experience they have acquired will be of great value in dealing with the effluent problems.

Head Wrightson, aided by their associate companies, have long experience in the construction of special plant and have recently extended their activities into the water treatment field.

Whenever possible, the approach to the solution of problems will follow chemical engineering practice to facilitate the incorporation of standard plant of proved performance and to avoid expensive civil engineering works.

In August of last year, Simon-Carves and Monsanto announced their intention of pooling knowledge in this field (see CHEMICAL AGE, 13 August, 1960, p. 235) but this was in order to form a joint advisory service.

Gas Chromatography of Polyphenyls

The U.K. Atomic Energy Authority's unclassified report, AERE-M 820, describes a simple apparatus for the gas chromatography of polyphenyls. The apparatus, which is designed to deal with both solid and semi-liquid samples, makes use of model engine glow plugs for the detectors and a column of alumina with no liquid phase. The normal running temperature is 425°C.

Wellcome Oral Polio Vaccine for U.K.

AT the request of the Ministry of Health the Wellcome Foundation have reserved some of their stocks of oral polio vaccine for possible use in the U.K. The Foundation have undertaken to do this in view of the fact that they are at present in active negotiation with several overseas countries seeking supplies of it.

This announcement follows a reply given to a Parliamentary question concerning vaccination against poliomyelitis, in which the Minister stated that the vaccination programme should continue to employ vaccine administered by injection, but that the committee are studying the information available about oral vaccine. They have made an interim arrangement that a stock should be available for emergency use in a community or area where poliomyelitis becomes, or shows signs of becoming, prevalent.

Last December the Foundation expressed the view that they believed the future was more likely to lie with the oral vaccine and accordingly diverted facilities to the production of an oral vaccine using the strains developed by Sabin (see CHEMICAL AGE, 31 December, 1960, p. 1084).

U.K. Fertiliser Producers Tour East Germany

A TEAM which represented some 80-85% of U.K. compound fertiliser production was taken on a four-day tour of East Germany's potash mines and installations earlier this month. The visit was organised by Propane Fertilisers Ltd., the U.K. and Eire agents of Bergbau-Handel, the East German Mining Products Export Organisation, which was host to the delegation. The team included representatives of Fisons Fertilizers Ltd., I.C.I. Ltd., Lindsey and Kesteven Ltd., Lawes Chemical Co. Ltd., A.C.C. Ltd., the Farmers Co. Ltd., and S.A.I. Ltd.

The party visited the enormous mines in the Unterbreizbach area (near Erfurt), where the miners drive to the working face on motorcycles stored at the foot of the lift. Surface working and refineries were also inspected. One mine produces 30,000 tons of raw salts a day.

Duty Relief Sought on Nuclear Fuels

THE Board of Trade are considering an application for the removal of import duty on nuclear reactor cartridges, spent or irradiated and uranium enriched in uranium-235. A statement of the applicant's case will be made available if firms and organisations are prepared to undertake to treat the information contained as strictly confidential and to allow their comments to be passed to the applicant for reply.

Requests for a statement of the case, with the required undertaking, should be sent to the Board of Trade, Tariff and Import Policy Division, Horse Guards Avenue, London S.W.1. not later than 12 May. Comments on the application should reach the B.o.T. not later than 26 May.

Major Export Drive for Fisons

NEW COMPANY WILL BOOST GROUP TRADE IN CHEMICALS

AN intensive drive to raise the Fisons Group chemical exports above the current level—they represent 40% of total chemical sales—will see the setting up in every important world market of at least a nucleus organisation of a permanent nature. This is one of the main objectives of Fisons Overseas Ltd., formed out of the Fisons Chemicals (Exports) Ltd to control all the overseas activities of Chemical Division companies.

The new company will also establish manufacturing activities and if necessary acquire existing companies. Organisations will be set up in the U.S. and other countries—they already exist in Australia, Canada, India and in many African countries. Spearheading this new export drive will be two industries of fundamental world importance—pharmaceutical and pest control. Group industrial chemicals include hydrazine and hydrazine derivatives.

Formation of this new company and reorganisation of the Chemical Division's activities were announced last week by Sir Clavering Fison, chairman of Fisons Ltd., and Mr. A. Wormald, a joint managing director of Fisons, who is chairman of Fisons Overseas Ltd.

20 Associated Companies with £6 m. Turnover

Fisons Overseas will be associated with 20 companies of the group operating abroad and with a turnover of about £6 million a year it will become one of the largest of Fisons subsidiaries; particular efforts will be made to raise group earnings from chemicals in South America and the U.S. The new company will make investments abroad; Fisons stake in India will be extended—perhaps also in the U.S., and elsewhere through the setting up of new plants.

Plans at present envisaged might total around £2 million to £3 million; certainly no more at this stage, but it is thought that these could become very much larger in the future. The new company will be responsible for licensing group products for manufacture overseas.

The new venture is designed to expand Fisons' chemical interests considerably and as soon as possible. Fertiliser exports will continue to be looked after by the Fertiliser Division; overseas the division has three or four associated companies operating, in which Fisons hold a 50% interest. Total fertiliser sales abroad in 1960 were just on £9.5 million.

Fisons main board considered on Monday this week a plan to bring the earnings of the Chemical Division as soon as possible on a parity with those of the Fertiliser Division. Sir Clavering stated last week that this did not neces-

sarily imply the investment of the same amount of capital.

Fisons export trade in chemicals has built up from a total of £750,000 in 1950 to a figure of nearly £4 million last year. On pest control products. Fisons are closely associated with J. R. Geigy AG, Basle, but where these products are concerned, the home market is not regarded



A. Wormald announces formation of Fisons Overseas Ltd. On his left is Sir Clavering Fison

as the most important; the big markets are overseas in countries where agricultural industries are being developed. It is felt that some 75% of the business of Pest Control Products Ltd. should be overseas and perhaps 50% or more for pharmaceuticals.

Fisons base their policy on the assumption that the U.K. will sooner or later become a part of the Common Market. The group already has considerable business in the area in industrial chemicals and pharmaceuticals; their pest control business in the C.M. is taken care of by Geigy.

(As stated in CHEMICAL AGE, 8 April, p. 576, Fisons Fertilisers Ltd. and Union Chimique Belge, are to set up plant near Ostend for the production of high analysis granular compound fertilisers).

The company now believes that the present is an opportune time to start a very intensive export effort. Firstly there is the banding together of Western countries in trade blocs; secondly, former dependent countries are increasingly becoming independent and are also showing economic stability and growth; thirdly South American countries are now much more stable.

The Soviet Union is looked on as offering a very considerable and continuing market for the most advanced technical products of the West. That also applies to China. Fisons business with mainland

China is small, but it is intended to expand it. In fact, Mr. Wormald declared that never had there been a time when British industry could take such an expansionist view of possibilities in the world.

Fisons feel that now is the time to exploit world markets. Their confidence is based on a strong management team and an increasing flow of research-based products. Such products are not subject to the same intensive competition as other lines, they often contain only a small content of imported raw material and frequently command high prices. Fisons policy is to sell products of original research and so they are constantly increasing their research endeavour. Spending on research for chemicals now amounts to between 6 and 7% of total turnover in chemicals; well above the chemical industry's national average of 2-3%. Although this is a heavy burden, in the long run it is felt that the company must benefit. Fisons feel that to rely on products licensed from other countries would be to limit earnings, for such licences usually restrict sales to certain areas.

In research work, Fisons collaborate on general lines with Geigy, co-ordinating their efforts. Under the new overseas company, research will be increased in other countries, but Mr. Wormald pointed out that not only is the quality of British research extremely good, it also costs about one-third less than research carried out in the U.S. or Canada.

Take-over Policy

Mr. Wormald, speaking at a Press conference in London, took the opportunity of stating the company's policy on take-overs. He said that one company which Fisons failed to capture last year had just published its annual results; they did not do too well and certainly not as well as they suggested they would when they frustrated "our well meant endeavours." He wondered if the Press still held the view that Fisons' offer was not good enough.

The company's take-over policy is to decide fairly early what it intends to pay; if it cannot get the business sought at that price, it then turns to alternative uses for its money, rather than to step in with a higher, unrealistic bid.

"We have looked around to see how we could employ our resources to the best advantage of our shareholders," declared Mr. Wormald. One way was to extend very considerably their overseas interests.

Fisons have not given up the idea of acquiring other companies, but this will only be done at reasonable prices. Currently chemical firms of interest to the group have a scarcity value and, as a result, are highly priced.

At the moment, the group's funds are heavily committed and, Mr. Wormald added, an announcement would be made within the next three months which would show the directions in which very large investments would be made.

The group still intends to expand its interests in food, but is not contemplating any take-over bids for the time being;

REPRODUCED BY THE NATIONAL ARCHIVES

REPRODUCED BY THE NATIONAL ARCHIVES

first of all it is consolidating its position in this field.

Chief executives of Fisons Overseas Ltd. are:

Mr. A. Wormald, chairman of Fisons Overseas, was appointed commercial director of Fisons Ltd. in 1950 and is a former managing director of the Chemical Division. He is one of the two managing directors of Fisons Ltd.

Mr. A. Robinson, who like Mr. Wormald is 48, has been actively associated with the development of Fisons' export business for more than 10 years, having been the first managing director of Fisons Chemicals (Export) Ltd. He is chairman of Whiffen and Sons Ltd.

Managing directors of the new company are **Mr. H. J. Kahn**, aged 48, and **Mr. W. Abel Smith**, aged 31. Mr. Kahn joined Fisons Pest Control in 1954, later becoming market research manager. He has been F.P.C.L. overseas manager since 1958 and has been closely connected with the formation of subsidiaries in India, Ceylon and Canada. He joined the F.P.C.L. in 1960. Mr. Abel Smith joined Fisons commercial department in 1953 and opened an office in New York to develop U.S. business. He then became assistant to Mr. Wormald and was concerned with the formation of Fisons Canadian subsidiary and was that company's first president.

Battelle Perfects One Stage of Oxygen Recovery System for Astronauts

ONE of the major problems of sending men into space is the provision of a system whereby carbon dioxide is converted into usable oxygen. The necessary oxygen recovery system would consist of three parts; a device to recover exhaled carbon dioxide from the cabin of a space vehicle; a device to convert the carbon dioxide into carbon and water; and a device to electrolyse the water into hydrogen and oxygen.

According to the Battelle Memorial Institute, U.S., a prototype of the device to convert carbon dioxide to carbon and water has been developed as a result of work sponsored by the Air Research Development Command. It is designed to operate on space voyages lasting for three years.

The Battelle apparatus uses an adaptation of the process formerly used to manufacture fuel gas from coal. Carbon dioxide, fed in at a rate of 500 c.c. per minute, reacts with hydrogen over a heated iron-containing catalyst (a combination of steel wool and iron oxide pellets) to produce water vapour and solid carbon.

The condensed water vapour will be fed to an electrolytic cell (now under development at Battelle) where it will be broken down into breathable oxygen and hydrogen. The hydrogen will be used to react with more carbon dioxide. The solid carbon will be removed from the reactor every two or three days and discarded.

A.B.P.I. Hits at Recommendation to Prescribe B.P. and B.P.C. Drugs

A REPORT recently published by the Joint Standing Committee on Classification of Proprietary Preparations, whose chairman is Lord Cohen, says that National Health doctors need not normally go outside the drugs and preparations described in the British Pharmacopoeia, the British Pharmaceutical Codex and the British National Formulary, together with certain new drugs. Where the doctor goes outside these drugs and preparations he may be called upon to justify his action if the cost of his prescribing is being formally investigated.

The Association of the British Pharmaceutical Industry condemns the report as being most discouraging to those pharmaceutical manufacturers who carry out research and development and make important contributions to the U.K. export trade.

As was pointed out in the reservation made by two members of the Cohen Committee, the strength and prosperity of the industry depend upon the sale of branded goods of quality, whose names and those of their manufacturers enjoy a world wide reputation.

Restrictions on prescribing that doctors are asked to make, say the Association, can only result in slowing down the rate

of therapeutic advance and in making the U.K. increasingly dependent upon imported drugs.

Fall in Chemicals Wholesale Price Index

DESPITE an increase in the wholesale price index for all manufactured products in March, the index for chemicals and allied industries showed a slight fall compared with February and a larger fall over March 1960. Based on a 1954 average of 100, the following is an extract from the Board of Trade index:

	March 1961	Feb. 1961	March 1960
All manufactured products:			
Total sales	114.7*	114.4*	112.2
Home sales	114.8*	114.4*	111.9
Chemicals & allied industries:			
Total sales	102.8*	102.9*	105.4
Home sales	105.2*	105.3*	106.8
General chemicals	103.9*	103.9*	105.2
Pharmaceutical chemicals	81.0*	81.2*	81.6
Pharmaceutical preparations	99.4*	100.2*	101.3
Soap	129.6	129.6†	128.8
Soapless detergents	103.6	103.6†	103.6
Synthetic resins & plastics materials	87.0*	87.1	89.5
Commodities wholly or partly imported			
Pyrites, c.i.f. U.K. ports	61.5	61.5	65.9
Sulphur, crude (for acid making), c.i.f.	71.7	71.7	75.6

* Provisional figure.
† Revised figure.

C.A. Title Incorporates 'Petrochemicals and Polymers'

Change in 'Chemical Age' title this week—to incorporate 'Petrochemicals and Polymers'—acknowledges changing trends in the structure of the chemical industry. For the past few years developments in these fields have been taking increasing space in our pages and will obviously do so even more in the future.

In 1959, out of a total U.K. organic chemicals production of 1.3 million tons, some 600,000 tons came from a petroleum source; compared with about 400,000 tons from coal tar, about 140,000 tons from carbide, an estimated 100,000 tons from synthesis gas (coke) and some 80,000 tons by fermentation. By 1962, U.K. organics production is expected to reach 2.25 million tons, of which 1.5 million tons will be based on petroleum feedstock.

By 1962 petroleum feedstock for chemicals will total some 4.3 million tons; in that year investment in petroleum-based organics alone will reach an estimated total of £200 million, compared with £140 million in 1960 and about £40 million in 1955.

There will be no change in 'Chemical Age's' basic editorial policy; this journal will continue to be first with the news each week, whether it concerns petrochemicals, polymers, coal-tar chemicals, acetylene, coke-oven production or fermentation processes.

Unilever Entertain C.S. Members

FOUR hundred guests were received by Lord and Lady Leverhulme and Sir Alexander and Lady Todd at Port Sunlight on 12 April when the directors of Unilever entertained Chemical Society members at their anniversary meeting.

Sir Alexander Todd, addressing the Society at the dinner—which marked the close of the conference on 13 April, expressed concern at the gap separating the scientist and the artist in the U.K. He said that the Chemical Society was doing a great deal of valuable work to lead their Fellows into writing their papers on chemistry in plain, easily-understood English. The ordinary man and the artist could appreciate science much more if our schools rethought their teaching methods.

Imports of Mercury from U.S.S.R. Ended

Russian exports of mercury to the U.K., which began in November of last year, have come to an end, and are not expected to be resumed before 1962.

Caprolactam Projects Reflect Increasing Demand for Nylon 6

RECENT announcement of major projects for the production of caprolactam in Europe, the United States and the U.K., indicates the growing demand for this material, which springs from the expanding market for nylon 6. Already the leading type of nylon in Europe, nylon 6 had a late start in the U.S., but has grown rapidly since it was introduced commercially in 1954. By 1958, nylon 6 output in the U.S. had reached an estimated 38 million lb. Output figures for 1960 are not available but are probably close to the 48 million lb./year of plant capacity on stream during that year (and now being rapidly expanded). European output of nylon 6 greatly exceeds these volumes. While market figures are not available, production facilities for nylon 6 make up a major percentage of the 300 million lb./year polyamide fibre capacity which was on stream in Western Europe during 1960.

Commercial Synthesis of Caprolactam

Several methods for the commercial synthesis of caprolactam are practised. The bulk of present production starts from cyclohexanone, which is variously obtained from phenol and from cyclohexane. At least one producer is reported to derive caprolactam from cyclohexylamine.

A newcomer among caprolactam processes is Snia Viscosa's toluene-based synthesis. This approach, which benefits from a low-cost raw materials position, has already been licensed to Courtaulds in England and Allied Chemical in the U.S., and is believed to be the basis for at least two commercial plants under construction as of early 1961.

Production from Cyclohexanone. Cyclohexanone is obtained commercially from two sources: (1) *From cyclohexane* by liquid-phase air oxidation in the presence of a cobalt salt. The reaction product is a mixture of cyclohexanol and cyclohexanone. Following separation, further dehydrogenation will convert cyclohexanol to the desired ketone. (2) *From phenol* in a process involving hydrogenation to cyclohexanol followed by dehydrogenation to cyclohexanone. Conversion of cyclohexanone to caprolactam involves two chemical steps:

Production of cyclohexanone oxime:

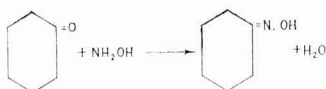

Allied's caprolactam plant, Hopewell, W.Va.

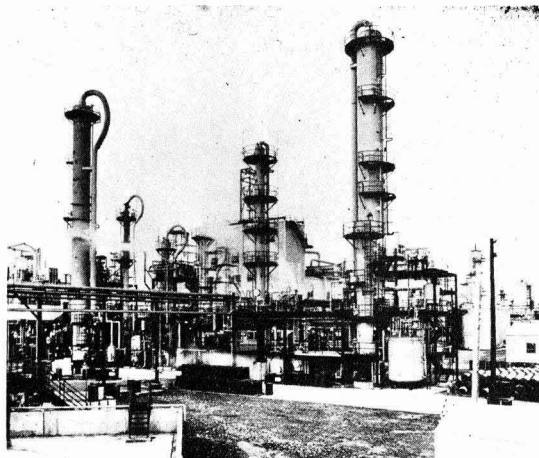

Beckman rearrangement of the oxime:

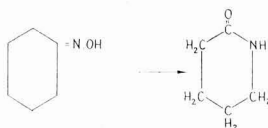

Information has become available on one commercial batch process for the production of cyclohexanone oxime. Here, a solution of hydroxylamine sulphate, cooled to 20°C, is mixed with cyclohexanone in 5% excess. Ammonia is passed in with vigorous stirring until the mixture becomes neutral. The product is withdrawn to a separator where the oxime settles out as an oily liquid, containing 4-5% water.

The crude product is used directly as feed to the Beckman rearrangement reaction stage (equation 2) where it is converted to caprolactam. For this conversion, sulphuric acid is the preferred catalyst, but a recent development by B.A.S.F. suggests certain advantages for use of HCl in this function.

In a typical execution of the Beckman rearrangement, 20 lb. of molten cyclohexanone oxime and 32 lb. of 97.8% sulphuric acid are introduced at separate points of the reactor liquid. Operating temperature is held below 140°C. Product is continuously withdrawn from the system, and caprolactam-containing solution is promptly cooled below 75°C to avoid hydrolysis. It is then cooled further and neutralised with ammonia. Following phase separation, the lactam is recovered by vacuum distillation or by solvent extraction (e.g., by benzene). Yield is reported in the range of 90-93% of theory, based on the oxime.

From Cyclohexylamine. Cyclohexylamine is produced by the hydrogenation of aniline, using such catalysts as nickel, cobalt, or ruthenium oxide. In an alternative synthesis, the amine is derived from cyclohexanol by reaction with ammonia and hydrogen over a nickel catalyst of the Raney type.

Cyclohexylamine is converted to cyclohexanone oxime by reaction with hydrogen peroxide (supplied as 30% aqueous

solution). In one commercially interesting process, the conversion is carried out in two stages: Formation of an addition compound of the amine with hydrogen peroxide by reaction at 0°C, followed by conversion to the oxime at 15°C. The second of these conversions is catalysed by a 1-2% aqueous solution of sodium or ammonium tungstate. Yield of cyclohexanone oxime is reported at 94-95% of theory.

In this conversion, cyclohexanone oxime is produced in very high purity (reportedly 99.9%). The product is converted to caprolactam by the Beckman rearrangement, as outlined above.

From Toluene. Snia Viscosa's caprolactam process involves the reaction of hexahydrobenzoic acid with nitrosyl sulphuric acid. Several intermediate reaction steps are required:

(1) Production of nitrosyl sulphuric acid by a simple exothermic addition reaction of sulphur dioxide with fuming nitric acid.

(2) Production of benzoic acid. Several approaches are practical for the commercial synthesis of this compound. Raw material is toluene which may be oxidised by air, by sulphur dioxide, or by sulphur. Most interesting approach is liquid-phase air oxidation. Catalyst systems include bromine-promoted manganese salts or ketone-promoted cobalt salts.

(3) Production of hexahydrobenzoic acid. This is achieved by hydrogenation of benzoic acid. Employing chlorine-free palladium or platinum black as catalyst, the reaction can be effected in alcohol solution, with nearly quantitative yield.

Conversion of hexahydrobenzoic acid to caprolactam is the heart of the Snia Viscosa process. The reaction with nitrosyl sulphuric acid is carried out in the presence of oleum. Best results are reported at a ratio of nitrosyl sulphuric acid to hexahydrobenzoic which is slightly in excess of unity. Total amount of sulphuric acid (including the quantity in the nitrosylation agent) is 2.5 moles per mole organic feed material. Operating temperature is gradually raised from 55-65°C. The reaction is allowed to con-

(Continued on page 658)

G.L.C. Technique Developed in U.S. for Work at 1,000°C

A NEW development in the technique of gas chromatography has been achieved by Dr. C. B. Euston and Dr. A. J. Martin of F. and M. Scientific Corp. (*Chem. and Engng. News*, Vol. 39, No. 9). These research workers have produced an apparatus capable of operating at 1,000°C—twice the previous limit for such equipment. Although it is recognised that ultra high temperature chromatography will never have the universal application of the low temperature chromatography, for certain specialised uses, such as the analysis of certain inorganic salts and metal impurities, this new device may prove useful. It may also find use in small lot purification of metals, the determination of oil content of shales and the investigation of inorganic reaction mechanisms, catalysis and thermal stability problems.

The apparatus uses a hydrogen flame ionisation detector and heats the column by means of its own electrical resistance. The greatest difficulty of high temperature chromatography—that of finding a suitable packing material for the column—appears to have been overcome. Such materials as alumina, silica gel and inorganic salt eutectics have been used as

part partition media. Other materials are being investigated.

A feature of the apparatus is the incorporation of an injection port, flame jet and column in a single length of stainless steel tube. The tube is bent in a U shape mainly to conserve space. A heater, which surrounds the injection end, helps vaporise the sample and heats the carrier gas, helium or nitrogen.

Hydrogen is fed into the other end of the tube, near the end of which is a small nipple welded to the column so forming a jet. The hydrogen burns at the jet ionising the material moved by the carrier gases. An ion detector ring is located just above the jet.

Generation of heat along the entire length of the column is achieved by the electrical resistance of the column itself when placed in an electric circuit. A temperature of 1,000°C can be obtained in less than five minutes with 120 amps.

High temperature gas chromatography has already been used to detect five chloride salts. However, resolution of mixed chlorides is not always good. More work is needed before the apparatus can be made useful.

New Membrane Permeation Cell Separates Close-boiling Mixtures

A NEW laboratory-scale membrane permeation cell incorporating new developments in using selectively permeable membranes for changing the composition and separating components of fluid mixtures, has been introduced by Ionics, Inc. of Cambridge, Massachusetts.

Membrane permeation is a new unit operation technique in which membranes are used to permit easier passage of one or more of the components of a mixture relative to the remaining component. Appropriate selection of membranes and operating conditions such as temperature and pressure, make possible the effective separation, for commercial purposes, of various components in industrial process streams.

Typical of the many applications which lend themselves to membrane permeation techniques are the breaking of azeotropes, separation of close-boiling mixtures, removal of water from organics and driving equilibrium reactions to completion.

According to company officials, the new permeation cell makes possible complete process research investigations of promising commercial applications at the laboratory level, including economic evaluations, determination of process variables and membrane selection and development programmes leading to optimum pilot plant designs and full-scale commercial processing cost estimations.

In the new cell all metal parts in contact with fluids to be tested are made of stainless steel. The cell has a nominal volume of 0.4 gall. and an effective membrane area of 0.165 sq. ft. Standard rated working pressure is 150 p.s.i.g. at 325°F.

The cell is equipped with a heating mantle, pressure gauge, thermometer well, and may be operated on a batch or continuous basis. An internal chamber provides a means for rapid cooling. If desired, the chamber also may be used as an alternative heating or temperature control system. A variable-speed stirrer promotes uniform temperature and composition throughout the charge.

Caprolactam Processes

(Continued from page 657)

tinue until the evolution of by-product carbon dioxide ceases.

Per-pass conversion of the organic feed material is reported at 61%, and ultimate caprolactam yield is about 90%.

In the production of caprolactam from cyclohexanone and from toluene, large amounts of sulphuric acid must be neutralised, Ammonia is generally employed. Thus, Snia Viscosa's plant at Trieste will produce 4.5 lb. ammonium sulphate per lb. of caprolactam. It is evident that the achievable ammonium sulphate price has a major influence on caprolactam economics.

O.E.E.C. Urges World Co-operation on Water Pollution Research

IMPROVED international co-operation in scientific research on water pollution is the object of recommendations made by a group of experts at a meeting in Paris organised by the Applied Research Committee of the Organisation for European Economic Co-operation. The meeting recommended the setting up of working parties for co-operative research on methods for determining the degree of pollution of water courses and estuaries; standardisation of sampling methods and chemical, biological and other forms of analysis; studies on water pollution due to detergents; and preliminary study on the mixed treatment of household and industrial effluents.

The experts recommended further, that O.E.E.C. should prepare an international inventory of laboratories concerned with research on water pollution, and that each member country appoint a body to be responsible for centralising all information relating to research laboratories.

The group of experts also considered that the O.E.E.C., working in close touch with other international organisations, should consider the possibility of setting up machinery to provide member countries with up-to-date documentation and information concerning research on water pollution.

New Nuclear Engineering Firm Formed in U.K.

A NEW company to operate in the field of civil nuclear engineering in collaboration with the atomic power consortia has been formed by I.C.I. Metals Division, Rolls-Royce Ltd. and the Rio Tinto Co. Ltd. The company is to be called Nuclear Developments Ltd. and the United Kingdom Atomic Energy Authority has been kept fully informed of its formation.

Rio Tinto mine, extract and process uranium on a large scale. Rolls-Royce have been engaged in the nuclear field for the past eight years and have a specific interest in marine nuclear propulsion, while I.C.I. Metals Division have made several notable contributions to technological progress in nuclear engineering over the last 20 years and have exceptional facilities for the manufacture of nuclear metals and reactor components.

International Aerosol Congress and Exhibition

The third International Congress organised by the Federation of European Aerosol Associations (F.E.A.) under the auspices of The International Aerosol Association (I.A.A.) will be held from 4-6 October 1961 in the Congress House, Lucerne, Switzerland. An innovation this year will be an Aerosol Packing Contest.

The first International Aerosol Exhibition will be held during the period of the Congress but will cover two extra days, running from 4 to 8 October 1961.

Prince Philip Pinpoints Need to Develop Commonwealth's Large Mineral Resources

THE point that, in mineral resources the Commonwealth had hardly begun to tap the known deposits of Canada and Australia, while in India and Africa the survey had not been properly completed, was made by the Duke of Edinburgh when he gave the Seventh Graham Clark lecture at a meeting of the Institution of Civil Engineers in London on 13 April. Under the title 'The engineer in Commonwealth development', the Duke surveyed the role of the engineer in developing not only mineral resources, but industry, energy, communications and food and agriculture, scientific research, education and training.

The Duke said that the Commonwealth fraction of the world land area was 23%; the world population fraction was 24%. To stimulate and raise agricultural productivity, he called for an extension of the area under cultivation by irrigation, the removal of water in swamps, and the control of pests, diseases and weeds; an increase in soil productivity by applying more nutrients; and better equipment for farming so that with higher fertiliser usage, output per acre could be substantially improved.

The gap in material standards between the more fortunate countries and those that were less developed could only be reduced by a real co-operative effort declared the Duke. That meant a co-operative effort by engineers in the Commonwealth.

Commonwealth Resources

In well-documented appendices, statistics were given relating to the Commonwealth's mineral resources. The picture is constantly changing, and the following extract is no more than a reasonable estimate in the light of existing surveys and current conditions of the reserves capable of use in the foreseeable future. These show that the Commonwealth has recoverable reserves of at least 200 million tons of sulphur (anhydrite and gypsum); 60 million tons (pyrites, etc.); and 40 million tons (natural gas).

UNITED KINGDOM	
Petroleum	About 2 m. tons
Potash	140 m. tons potassium oxide
Sulphur	60 m. tons anhydrite & gypsum

CANADA	
Natural gas	Over 25 m. cu. ft.
Nickel	5 m. tons, plus
Petroleum	Over 500 m. tons
Phosphates	25 m. tons of ore (20% apatite)
Platinum metals	Very large
Potash	17,500 m. tons potassium oxide (est.)
Sulphur	46 m. tons in pyrites & sulphur-bearing minerals; est. 40 m. tons recoverable from natural gas; large deposits in bituminous sands and gypsum-anhydrite
Thorium	170,000 tons
Titanium	150 m. tons of ilmenite-hematite ore, containing 35% TiO ₂ , plus other deposits
Uranium (metal)	350,000 tons

AUSTRALIA	
Rutile	2.5 m. tons; plus ilmenite reserve
Sulphur	14.9 m. tons in pyrites and pyrrhotite, & in lead & zinc sulphides; 140 m. tons in gypsum
Thorium	40,000 tons
Uranium	12,000 tons
Zircon	Abt. 1.5 m. tons
CHRISTMAS ISLAND	
Phosphates	Over 30 m. tons (80% tricalcium phosphate)
NAURU ISLAND	
Phosphates	Abt. 65 m. tons (83% tricalcium phosphate)
UNION OF SOUTH AFRICA	
Chrome ore	Free-world's biggest source chemical grade, reserves totalling over 100 m. tons, plus abt. 2 m. tons of metallurgical ore
Ilmenite	2 m. tons
Phosphates	85 m. tons (10-12% P ₂ O ₅), plus big reserves of lower grade ore
Platinum metals	Large reserves
Thorium	12,000 tons
Uranium	300,000 tons
INDIA	
Ilmenite	50 m. tons
Natural gas	1,000 m. cu. ft.
Petroleum	Abt. 75 m. tons
Phosphates	Abt. 700,000 tons (20-25% P ₂ O ₅), plus 8 m. tons (24-27% P ₂ O ₅)
Rutile	2 m. tons
Thorium	240,000 tons

Natural gas	PAKISTAN	Abt. 5 million million cu. ft.
Petroleum		Abt. 3 m. tons
Ilmenite	CEYLON	4 m. tons
Ilmenite	FEDERATION OF MALAYA	Considerable
Petroleum	NIGERIA	Abt. 3.5 m. tons
Phosphates		Small reserves known
Thorium		By-product of columbite, 12,000 tons
Lithium minerals	SOUTHERN RHODESIA	Large
Phosphates		37 m. tons (8% P ₂ O ₅)
Thorium	NYASALAND	8,000 tons
Soda ash	KENYA	Large
Phosphates	UGANDA	Over 200 m. tons (13% P ₂ O ₅)
Rutile	SIERRA LEONE	Large reserves
Petroleum	BORNEO	75 m. tons
Phosphates		60,000 tons (10-20% P ₂ O ₅)
Phosphates	JAMAICA	100,000 tons (25-31% P ₂ O ₅)
Petroleum	TRINIDAD	55 m. tons
Phosphates	FIJI	Up to 200,000 tons iron-aluminium phosphate.
Phosphates	SOLOMON ISLANDS	8 m. tons iron-aluminium phosphate
Phosphate	OCEAN ISLAND	Abt. 8 m. tons (85% tricalcium phosphate)
Phosphates	SEYCHELLES	Small reserves known

Spectroscopy Will Be Chemistry Section Theme at Norwich B.A. meeting

THE 123rd annual meeting of the British Association for the Advancement of Science will be held in Norwich from 30 August to 6 September under the presidency of Sir Wilfrid Le Gros Clark, F.R.S., Professor of Anatomy, Oxford University. No scientific qualifications are required for membership—all interested in the progress of science can join the B.A. and attend the meeting. Details are available from the secretary at 18 Adam Street, Adelphi, London W.C.7.

President of the Chemistry Section for 1961 is Professor R. G. W. Norrish, F.R.S., Professor of Physical Chemistry, Cambridge University, who will give his presidential address on 'Chemistry and the spectroscope'. Other Chemistry Section papers, which will stress the subject of spectroscopy are: 'Spectroscopy as a biochemical tool', 'Analytical and industrial applications of spectroscopy', 'Chemical studies in the infra-red', 'Absorption and emission spectroscopy of explosive reactions, with reference to knock and anti-knock in the internal combustion engine', 'The Darwin Lecture', 'Training of food scientists for industry', 'Molecular structure and reaction revealed by microwave and radio frequencies'.

Chemistry Section meetings will be held at Hewett School, Norwich. Section visits include those to Fisons Ltd.,

Ipswich, J. and J. Colman Ltd., Norwich; Dow Agrochemicals Ltd., King's Lynn, I.C.I. Paints Division, Stowmarket; and May and Baker Ltd., Norwich.

Apart from Professor Norrish, other Chemistry Section officers are: *Vice-presidents*, H. F. Bamford, J. W. Beeson, Dr. J. W. Corran, Dr. J. C. Earl, F. J. Paxon, Dr. W. E. Ripper, Dr. E. W. Schwehr, Dr. James Taylor and Dr. E. C. Wood; *hon. recorder*, Dr. I. J. Faulkner, Parkhurst, Eaglescliffe, Stockton-on-Tees; *hon. secretaries*, Dr. Bernard Atkinson and Professor W. G. Overend; *local hon. secretary*, S. Trett, City of Norwich School, Eaton Road, Norwich.

U.K./Canadian Uranium Talks Postponed

FOLLOWING the recent meeting between Mr. Macmillan and Mr. Diefenbaker, the talks between the U.K. and Canadian authorities to renegotiate the agreement between the two countries concerning uranium oxide, which were to have begun on 24 April, have been postponed. The British commitment is now to be discussed at Cabinet level. The original agreement, under which the U.K. was to buy 2,000 short tons of Canadian uranium oxide at £3 13s a lb., was made in 1957.

Berk Chairman Reports Record Levels for Sales and Profits

ALL-TIME records, both of sales and profits, for 1960 will be reported by the chairman of F. W. Berk Ltd., Mr. C. H. Turner, in his address at the company's annual general meeting on 11 May. Group sales of £9,024,200 were 8% higher than the previous year. The profits of the group at £334,893, after providing £349,894 for taxation, show an increase of 26%. Broadening of the company's activities is stated to be largely responsible for the improved results. Outstanding in the past year has been the increased business secured in organic mercurial compounds, clay and allied products, organic and fine chemicals and agricultural chemicals. Berk's recent entry into the pharmaceutical field is being actively fostered through Leda Pharmaceuticals, a wholly-owned subsidiary. Profits of Detarex Ltd., London Colney, who make a range of organic chelating agents, continue to rise.

Notable activities of F. W. Berk and Co. during the year include the acquisition

of a 25% interest in Bromine Compounds Ltd., Israel, a new company formed in conjunction with the Dead Sea Works Ltd. and American interests to develop the manufacture and marketing of compounds based on bromine from the Dead Sea.

A further announcement is that the production capacity of Berk Exothermics Ltd., Wolverhampton, is being increased to meet the growing demand for exothermic powders, sleeves and plaquettes used in steelworks and metal foundries for controlled feeding of ingots and castings. This unit is expected to become profit-earning in the current year.

During 1960 Berk's fixed assets have been revalued on a going concern basis; the valuation shows an increase over book figures of some £1 m., divided almost equally between land and buildings, and plant and machinery. As previously reported, the dividend is 8½d per 5s share on increased capital, against the forecast of a maintained total of 7½d.

Sturge Budget for Near Capacity Production and Sales in 1961

NEAR capacity production and sales are budgeted for the U.K. works of John and E. Sturge Ltd., fine chemicals producers, 1 Wheelcys Road, Birmingham, for this year. Mr. A. L. Wilson, chairman, in his annual report, says that development activity is in hand at six plants; he prophesies that 1961 will be a busy year, but adds that it is too early to make any accurate profit forecast.

In spite of the fact that first quarter sales are below budget, Mr. Wilson sees no reason to lower the company's targets. Apart from unforeseen eventualities, group profitability should be similar to last year.

During 1960 the bank overdraft was cut by some £140,000, tax certificates worth £75,000 were purchased, while

capital spending totalled £282,386 and additional funds of £22,000 were passed to subsidiaries. Development plans this year envisage similar capital investment. Mr. Wilson stated that a satisfactory reduction in production costs was already apparent as a result of concentrating manufacturing operations at Selby.

The Canadian subsidiary made only a small contribution to group profitability and Mr. Wilson does not see any spectacular improvement in the near future. The French subsidiary made a loss.

Group pre-tax profit totalled £235,416, compared with a figure of £258,000 forecast when the public issue was made last June. The disparity was due to adverse trading conditions.

MacLellan Rubber Lining for Large Hydrochloric Acid Tank

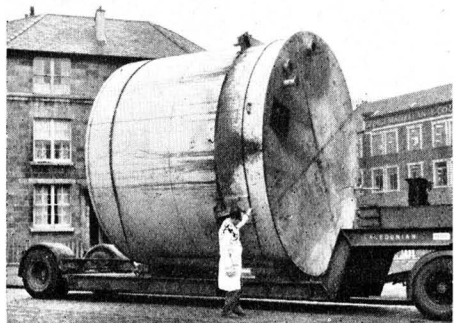

Giant hydrochloric acid storage tank leaving the Maryhill, Glasgow, works of George MacLellan and Co. Ltd. after being lined with anti-corrosive rubber. The tank, 13 ft. dia. and 15 ft. high, weighs 55 tons and has a capacity of 10,000 gal.

D.C.L., Monsanto and Shell Chemical Reduce Polystyrene Prices

FURTHER substantial reductions in their prices for polystyrene have been made by U.K. manufacturers. The Distillers Co. Ltd. have announced a cut of up to 15% for the full range of polystyrene manufactured by the two associates, Distrene and BX Plastics. Recently, Monsanto reduced the price of their crystal grade of polystyrene by 4d/lb.—early this year Monsanto brought in a price reduction of some 20% for their Polyflex 150 packaging film and Polyflex 100 sheet (C.A., 14 January, p. 98).

As C.A. went to Press we learned that the Shell Chemical Co. had, from 1 April, also cut prices of their Carinex polystyrene grades. Price for basic grade (QP, GP, MW, HR, HRM) in crystal/natural, all quantities, is now 1s 7d/lb., rising to 2s for toughened grade (TGH), heat resistant in crystal/natural.

Competition from cheap, imported styrene, particularly from the U.S., Canada and Italy, is believed to be influential in bringing down prices in spite of a 3d/lb. general reduction in U.K. polystyrene prices in the latter half of 1960.

S.C.I. Surface Activity Group Dinner

SUCCESSFUL system of groups in the Society of Chemical Industry, which could with wisdom be adopted by the Chemical Society and the Royal Institute of Chemistry, was referred to by Lord Fleck, F.R.S., K.B.E., president of the Society, at the annual dinner held in London last week of the S.C.I. Surface Activity Group. He was proposing the toast of the group, to which Sir Eric Rideal, group chairman, responded.

Toast of the guests was proposed by Mr. M. K. Schwitzer, hon. secretary, and replied to by Sir Alan Wilson, F.R.S., deputy chairman of Courtaulds Ltd.

I.C.I. Chairman at I.Chem.E. Annual Dinner

Chief guests at the annual dinner-dance of the Institution of Chemical Engineers, to be held at the Park Lane Hotel, London W.1, on 25 April will be Mr. S. P. Chambers, C.B., chairman, Imperial Chemical Industries Ltd., and Sir Keith Murray, chairman, University Grants Committee. The Institution's annual meeting will be held at the Park Lane Hotel at 10.45 a.m. the same day. Title of the presidential address, to be given at 12 noon by Mr. W. K. Hutchison, C.B.E., will be 'Industry, science and the chemical engineer'; this will be open to all grades of members and visitors.

E-Mil Maintain Prices

Despite three national wage awards, H. J. Elliott Ltd., laboratory glassware manufacturers, E-Mil Works, Treforest, Glam., have not raised their selling prices since effecting an overall 5% price reduction in February 1957.

Overseas News

CHINA PRODUCES 100 PETROLEUM PRODUCTS, SAYS NEW U.S. REPORT

ALMOST 100 types of petroleum products are being made in Communist China, which is now able to build 90% of its own petroleum prospecting and refining equipment, according to a report reviewing that country's progress in the coal and petroleum industries during the past 10 years. The report, No. 60-41439, 'Petroleum, synthetic and coal industries—Communist China' (62 pp., \$2.00) is one of four translated surveys of Communist Chinese and Russian industrial development released to science and industry through the Office of Technical Services, Business and Defense Services Administration, U.S. Department of Commerce, Washington 25, D.C.

China's plans to build a large factory for the low temperature carbonisation of coal and the hydrogenation of coal tar are nearing completion, the report states. Plants for making fused iron catalyst with water gas in a medium pressure fluidised bed are also being planned.

Method for Coating Polythene Both Sides Developed by Olin

The first commercially feasible method for coating polythene both sides has been developed by Olin Mathieson. The new film has a polymer coating, which adds resistance to the passage of oils, gases and flavours to polythene's basic durability and water vapour resistance.

The new film is now in pilot plant production and will be limited in supply for some time.

Known as PCP, the film has a transparency and gloss which is claimed to be superior to polythene. By use of a somewhat higher temperature than required on most packaging equipment used for polythene, coating-to-coating seal strengths equal to those of uncoated polythene are obtained.

U.S. Firm Doubles Capacity for Dodecyl Succinic Anhydride

Allied Chemical, New York, only U.S. producers of dodecyl succinic anhydride, have doubled production capacity for the intermediate since announcing a price cut last summer, and say they are now able to meet all foreseeable requirements. Another price cut seems likely if consumption continues to develop at the present rate. The cut slashed the price from 75 cents to 50 cents/lb. in truckloads and carloads, and to 52 cents/lb. in less truckloads and carloads.

Dodecyl succinic anhydride is polyfunctional, reacting both as an unsaturated compound and an acid anhydride. With three points for chemical reaction, the compound forms intermediates that lead to end-products such as plasticisers for polyvinyl and cellulose plastics, fungicides, viscosity index im-

provers, surfactants, wetting agents, and rust inhibitors for lube oils, fuels, hydraulic fluids, and protective coatings. It is also used in the curing of epoxy resins.

Man-made Diamond Industry Planned in S. Africa

Production of man-made diamonds on a commercial scale this year is planned by De Beers Consolidated Mines, South Africa. According to Mr. H. Oppenheimer, chairman of the group, this will provide "protection against the possibility of interference with regular production in the Congo." The bulk of the world's industrial diamond production is centred at Bakwanga, in the Kasai Province of the Congo.

Mr. Oppenheimer told the Commonwealth Mining and Metallurgical Congress that experiments had suggested that natural grit was more efficient than synthetic diamonds. But, he added: "We believe the market can be expanded to absorb large quantities, in addition to natural production."

Finnish TiO₂ Plant on Stream Soon

The new titanium oxide plant at Mäntyluoto, Finland, is starting production this month. Planned annual capacity is 16,000 tons. The plant will use Finnish raw material, ilmenite concentrate from the Otanmäki mine and sulphur pyrites from the Harjavalta works. Titanium oxide will be used by the domestic chemical industry and exported.

Shell and E.N.I. Projects Reported in Italy

Latest Italian reports indicate that Shell Italiana, the Italian branch of the Royal Dutch-Shell group, are planning large-scale investments for the erection of petrochemical units at their mineral oil refinery at Rho, near Milan. Some 100,000 annual tonnes of detergent materials and other products are reported to be planned for production there. It is further stated that the E.N.I. State holding company are to build a new refinery in the Lombardy area of northern Italy, which will have an annual throughput of 2 million tonnes.

Progress at New Refinery at Milazzo

Work on the new refinery which Societa' Mediterranea (Sarom Group) are building at Milazzo, Sicily, is advancing rapidly. The new plants occupy an area of about 700,000 sq. m.

Storage facilities of the refinery will consist of 50 tanks with total capacity of over 600,000 tonnes. A topping plant will have a capacity of 2,600,000 tonnes a year, while a catalytic reforming plant

with a capacity of 10,000 barrels a day, a thermal reforming plant, a fuel oil unit, and a chemical processing plant are also being built. Provision will be made for eventual expansion of these plants and for the addition of new ones.

The refinery is scheduled to go on stream early in 1962 and it will mostly process Middle East crude oil.

New Pliable Polyolefin from Dow

Dow Chemical has introduced a new polyolefin, called Zetafin, which is claimed to be as soft and as pliable as many flexible vinyls. It is a copolymer of ethylene and ethyl acrylate. Unlike some flexible vinyls, it does not degrade thermally during fabrication, does not need compounding other than for colour and has no plasticiser migration problems. The price is 32½ cents per lb. for truck-load quantities.

Israeli Company to Produce Formalin

Formalin is to be produced in Israel by a newly-formed subsidiary of the Atlit Salt Works. Formalin is a basic raw material for the country's flourishing plastics, plywood and pharmaceutical industries.

Bayer Have New Process for Sodium Boronate

A new process for the production of sodium boronate (NaBH₄) has been developed by Farbenfabriken Bayer, Leverkusen. Manufactured from borax, sand and sodium in a hydrogen atmosphere at a pressure of 3 atm., sodium boronate is a white, crystalline material. The new process will, it is said, mean considerable price cuts which will lead to greater usage of the material in the plastics, paper and other industries.

Syndet and Soap Unit Planned for Barcelona

Leve-Forêt, a new company being formed in Barcelona, have sought approval for the production of between 12,000 and 15,000 tons/year of synthetic detergents, 3,000 tons of scouring agent and 600 tons of toilet soap. Machinery and raw materials valued at 10.8 million pesetas and \$140,000 would be imported. Manufacturing rights, owned by Forêt, Barcelona, would be transferred to the new company, which will have a 110 million peseta-capital, with foreign participation of 62%.

W. Germans Imports Rose 32% Last Year

According to final figures for 1960 now released by the Verband der Chemischen Industrie E.V., Frankfurt-on-Main, Federal Germany, last year exported chemicals and chemical products worth DM6,200 million and imported chemicals and chemical products worth DM2,780 million. Exports were thus higher by 13.6% than in 1959 and imports as much as 32% above the 1959 figure.

Of all exports 64.3% (62.7%) went to

other European countries, that part of the total going to E.F.T.A. countries still topping the share taken up by Common Market countries. Shares in the whole were, respectively, 28% (26.9%) and 25.8% (23.9%). Export rose over the year to Asia and South America and fell to North and Central America, as far as share in the overall total was concerned, while the share of Eastern Europe continued to fall, reaching only 3.5% of the whole.

Main supplier of imports into West Germany remained the U.S.; although imports from the Common Market area rose by one-third over last year. The U.S. still supplied more than all the Common Market countries.

Three Fertiliser Plants Planned for Sicily

Societa Finanziaria Siciliana and Fertilia of Rome have set up jointly Biofert Sicilia, who will build three plants, respectively at Palermo, Catania, and Messina, for the production of compound organic fertilisers. Total capacity is scheduled to reach some 100,000 tonnes/year within two years.

Olin Form New Organics Division

All activities of the Energy Division of Olin Mathieson Chemical Corporation, plus organic chemicals operations at Bradenburg, Ky., have been included in a newly-formed Organics Division. Product range covers solvents and intermediates (including glycols and glycol ethers) ethylene oxide, glycerine, explosives, ammonium nitrate, solid propellants, brake fluids and anti-freeze chemicals.

Nitto to Build Ethanolamine Plant

A 200 lb. per month ethanolamine plant is under construction for Nitto Chemical Industry Co., Japan, and is expected to be completed this autumn. Nitto will produce their own ammonia for the plant and the ethylene oxide will be supplied by Nippon Shokubai Kagaku Kogyo Co.

Comecon Plans Big Build-up in Chemical Plant Trade

At a recent meeting of Comecon, the economic co-operation organisation for Eastern Europe, it was recommended to increase internal bloc deliveries of chemical plant by 1965 to almost 700% the figure recorded for 1958. At present the shortage of chemical plant in the area is resulting in the large-scale hold-up in chemical industry plants.

Ionics Allege Patent Infringement of Desalting Processes

Ionics, Inc., Cambridge, Mass., have filed two complaints of infringement of U.S. patents covering their electric membrane processes for desalting water and other solutions. American Machine and Foundry Co. were named in a complaint filed in the U.S. District Court of New Jersey; the four Ionics patents referred to in the complaint cover electric membranes, their commercial manu-

facture and use in electro dialysis systems and other features involved in the operation of electro dialysis systems. Aqua-Chem, Inc., Waukesha, Wis., were named in a second complaint.

More than 60 Ionics plants producing a total of over 1,200,000 gall/day of fresh water are now in operation in the U.S. and abroad. Ionics previously filed a petition in the Japanese Patent Office for an alleged infringement by Asahi Chemical, of Ionics' issued membrane patent in Japan.

Argentina's Demand for Synthetic Rubber

In connection with the petrochemical complex that will be installed at San Lorenzo, Argentina, by a group of U.S. companies, it is estimated that demand for synthetic and natural rubber in Argentina will be 44,000 tons this year, 51,000 tons next year, and 59,000 tons, 68,000 tons and 75,000 tons respectively in 1963, 1964 and 1965.

Houdry to Develop Fuel Cell with Gas Co.

The Northern Natural Gas Co., U.S., and Houdry Process Corp. have announced the establishment of a joint programme to develop a natural gas cell. The research will be conducted at Houdry's laboratories where fundamental research into fuel cells has been in progress for some time. The two companies aim to produce a fuel cell operating from natural gas which will produce electricity in the home and factory.

Israel's First Desalting Plant

Construction of Israel's first desalting plant is being started at Eilat. This plant, operating on the principle of freezing discovered by Dr. A. Zarchin of Israel, will process 60,000 gall. of sea water daily. The cost of processing is less than \$1 per 1,000 gall. and a further reduction of this cost is expected. The plant is being built by the Government of Israel in co-operation with Fairbanks Whitney Corp., U.S.

The Israeli Ministry of Development

will contribute 60% of the capital needed for this plant while Fairbanks will provide the rest.

This is the first of the four plants on schedule to supply drinking water to the city. They will cost, in all, about \$350,000. Power consumption and maintenance costs are 10W.

Within three years, works will be built in Israel for the mass production of such desalting plants.

Chemical Plant Exhibition to be Held at Milan

An exhibition of chemical equipment (MAC 61) will be held in some of the pavilions of Milan Fair from 30 September to 8 October. This exhibition will cover plants and equipment for the chemical industry, models, automation control and safety devices, materials for chemical packaging, laboratory equipment, and a display of technical literature.

Starting on 2 October a congress of Italian chemists will be held on the exhibition premises.

U.S. Chemical Fund Seeks New Investment Outlets

The United States-based chemical industry investment fund Chemical Fund Inc. has announced in New York that it will this year send a team of experts to Europe to seek new projects for investment. The Fund last year took up its first holdings in the European chemical industry. The Chemical Fund president also plans to study investment in Japan.

Plasticiser Increases Heat Resistance of P.V.C.

Commercial production has begun at Swift and Co.'s Ind. epoxidation plant of a plasticiser that is claimed to substantially increase the heat resistance of p.v.c. The plasticiser, made in the 8 million lb. a year expansion, is called Epoxol 9-5. It enables higher concentrations of the plasticiser to be used in p.v.c. formulations so improving heat stability of the finished product.

Addition to Australian Fertiliser Fleet

Seen taking on a load of anhydrous ammonia at I.C.I.'s Chester Hill works in Sydney, this new Anglo-American tanker outfit is the latest addition to the fleet of Australian Fertilizers Ltd. The tractor is a 150 h.p. Leyland Super Beaver, equipped with a step-up auxiliary gearbox and two 55 gall. fuel tanks. It is coupled to a tanker manufactured by the J. B. Beard Co. Inc., of Louisiana, U.S., which has a capacity of 6,330 gall.



● **Mr. Cyril E. Harrison**, vice-chairman and managing director of the English Sewing Cotton Co. Ltd., Manchester, who is aged 59, has succeeded **Sir William McFadzean**, chairman of British Insulated Callenders Cables Ltd., as president of the Federation of British Industries.

● **Mr. J. M. Maughan**, who joined the Humber Oil Co. Ltd., Marfleet, Hull, as works manager in the middle of last year, has been appointed works director.

● **Mr. W. E. van Os** has been appointed commercial director of the carbon chemicals and coalmining concern, Staatsmijnen in Limburg (Dutch State Mines).

● **Mr. D. A. Brighton**, who has been appointed an assistant technical service manager of Vinyl Products Ltd., Carshalton, Surrey, is a graduate of London University and joined the technical service department in 1953. He was previously in charge of the textile and paper sections of the technical service laboratory.

● **Mr. K. G. Burridge**, works manager of the International Synthetic Rubber Co. Ltd., and **J. Van Der Bie**, Shell International Chemical Co. Ltd., have been elected to the technical committee of the International Institute of Synthetic Rubber Producers Inc., New York.

● **Mr. J. W. Kerr**, commercial managing director of Imperial Chemical Industries, Ltd., Billingham-on-Tees, has retired through ill-health. His successor is **Mr. R. H. L. Cooper**, commercial director. **Mr. R. W. Pennock**, deputy manager of I.C.I. southern sales region, has been appointed Mr. Cooper's successor.

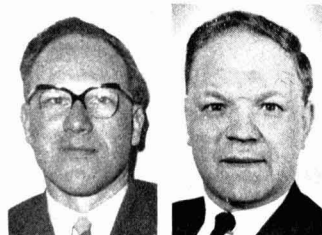

F. E. Broadfield, left, who as stated last week, has been appointed general works manager of **H. J. Elliott Ltd.** Right, **B. R. Corry**, new production superintendent of **Acheson Dispersed Pigments Ches.** (see C.A., 25 March, p. 518).

● **Mr. C. F. Bonnet**, associate regional director for Europe, has been appointed managing director of **Cyanamid International Corporation**, with headquarters at Zurich, as part of the company's further steps to develop its general chemicals business in Europe. Mr. Bonnet will mainly be responsible for sales development and the general co-ordination of promotion, sales and technical services. He will be liaison officer for **Cyanamid** subsidiaries and affiliates producing general chemicals in Europe. **Mr. R. T. Novotny** has been appointed manager marketing services, general

PEOPLE in the news

chemicals, for continental Europe and **Mr. L. Uytterelst** becomes manager, finance and administration. It is hoped that by decentralising general chemicals operations in Europe, **Cyanamid** will maintain closer contact with distributors and increase their technical service.

● **Mr. T. H. Makepeace**, D.F.C., manager, industrial developments, for **Chemstrand Ltd.**, has been appointed works director on the board of the **Aerosol Packaging Co. Ltd.**, Milbanke Way,



T. H. Makepeace

Bracknell, Herts. Forty years old and a graduate of **Magdalen College, Oxford**, he was previously general works manager for **Chemstrand's** acrylic fibre plant in Northern Ireland. The new appointment is due to the rapid expansion of **Aerosol Packaging**, a member of the **Thomas Tilling Group**, and the U.K.'s largest contract aerosol packagers.

● **Mr. Edward F. Beyer, Jr.**, of the **Grace Chemical Group**, has been appointed vice-president of the **Overseas Chemical Division**. **W. R. Grace and Co.**, New York.

● A three-man mission from the U.K. Atomic Energy Authority is going to **Sydney** for discussions with the **Australian Atomic Energy Commission** on research co-operation. The mission will consist of **Dr. H. Kronberger, O.B.E.**, deputy managing director (development), **Reactor Group**, **Mr. L. Grainger**, assistant director, **Atomic Energy Research Establishment, Harwell**, and **Mr. R. C. Orford**, commercial and overseas manager, **Reactor Group**.

Research results had been exchanged between the two bodies, and the **A.A.E.C.** is undertaking several research contracts for the **A.E.A.**, involving irradiation of

beryllium and uranium in the **Lucas Heights reactor HIFAR**.

● At the a.g.m. of the **Association of Consulting Scientists** held in London recently the following honorary officers were elected: chairman, **Dr. M. Barent** (Barent and Johnson), who was previously a member of the council; vice-chairman, **Mr. F. G. Sarel Whitfield** (Avebury Research Laboratories Ltd.); treasurer, **Dr. G. W. Ferguson** (Parry and Ferguson); and secretary, **Mr. W. H. Stevens** (W. H. Stevens).

● **Mr. D. Kenneth Finlayson** has been elected vice-president, sales, of **Scientific Design Co. Inc.**, international designers and builders of chemical plants, New York. He has been associated with **Bechtel International, Stone and Webster, E. B. Badger, Girdler**, and **M. W. Kellogg**.

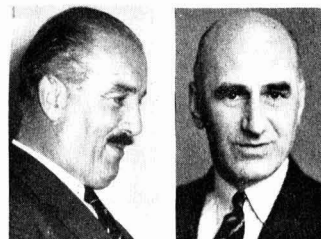

G. Hickson (left) and **Dr. F. S. Spring, F.R.S.**, who as stated last week, have joined the board of **Howards and Sons Ltd.**

● **Mr. J. B. Doyle**, head of the **I.C.I.** central safety department, will succeed **Mr. T. C. Robinson**, who retires as engineering works manager, **Billingham Division**, later this year after more than 30 years' service.

● **Mr. W. R. Owen** has been given responsibility for **Cardiff** and **Manchester** branches of **Honeywell Controls Ltd.**, in addition to continuing as **Birmingham** branch manager. This follows the transfer of **Mr. T. Jackson** and **Mr. R. Robson** from **Manchester** and **Cardiff** respectively to head office positions at **Greenford**. New market sales managers include **Mr. E. R. Amery** for the chemical industry.

● **Dr. Linton E. Cowart**, technical sales manager of agricultural and industrial chemicals of **Du Pont International, S.A.**, Geneva, has been appointed senior research scientist in the industrial and biochemicals department of the parent **Du Pont Company** in the U.S.

● Following the appointment of **Dr. R. Spence** as deputy director of the **Atomic Energy Research Establishment, Harwell**, **Dr. W. Wild** has been appointed head of the **Chemistry Division**. **Mr. A. A. Smales**, head of the analytical chemistry branch, has been given the status of a division head and will be directly responsible to the director, **A.E.R.E.**, for the scientific work under his control.

● **Mr. John H. Lord** has joined the board of **Whessoe Ltd.**, **Darlington**. He is a director of **Dunlop Rubber Co.**, **G. and J. Weir (Holdings)**, etc.

Methods for Determining Toxic Pesticide Residues Reviewed

THE increasing use of toxic pesticides in agriculture has led to the increasing awareness in Government and medical circles of the problem of safeguarding the consumer. For the purposes of implementing legislation, analytical methods are needed for determining residual contamination of foodstuffs, often in such trace amounts as to present a major technical problem to the analyst.

For several reasons the need for a method for organo-phosphorus compounds has come into prominence. These compounds are similar in chemical structure to compounds developed for chemical warfare and are therefore of notoriously high toxicity and they include the first organic systemic insecticides.

In a recent review of the methods of determining residual organo-phosphorus insecticides in foodstuffs (*The Analyst*, Vol. 86, p. 148) it is stated that the analytical methods in the literature fall into three groups, depending on the part of the molecule used; properties of the whole molecule; determination of phosphorus; a reaction depending on some

property of the organic radical, either while still attached to the phosphate radical or after hydrolysis.

Methods depending on the determination of phosphorus or specific reactions of the rest of the molecule form the major method of approach to the determination of radical residues. Each method has its own advantages and disadvantages, and the choice between them can only be made from a knowledge of the chemistry of each compound.

Phosphorus methods are non-specific, and the determination will include other phosphorus-containing insecticides; non-phosphorus methods can often be made specific for a single insecticide or at least for a group of related insecticides.

Methods depending on the non-phosphorus group have been extensively developed. They all use a specific reaction of the substituent group and cannot readily be classified.

The review is completed by the evaluation of a number of methods for specific compounds.

New Dow Compound May Give Controlled Fertilisation

CONTROLLED fertilisation of potted plants may be the outcome of a recent Dow Chemical development if a new controlled release fertiliser, now undergoing test marketing in Texas, goes into commercial production (*Chem. and Engng. News*, 39, 12).

Marketed under the name of Tydex C, the new fertiliser is based on an ion exchange resin which retains large amounts of needed inorganic nutrients in reserve as exchangeable ions. If thoroughly mixed with the soil at the time of planting, the fertiliser correctly releases the nutrients as the plant needs them throughout the period of growth, without the addition of further supplements. The plants are not harmed by excessive nutrients nor does overwatering leach them from the soil.

The fertiliser, which is a mixture of

cation (Dowex 50) and anion exchangers, provides nitrogen, phosphorus and potassium in addition to such minor elements as magnesium and sulphur. The mechanism has not been fully explained but it is believed that the nutrients are released when the roots come into contact with the exchanger.

This type of fertiliser has several advantages over the conventional potting materials: it eliminates frequent additions of fertilisers; it eliminates errors caused by incorrect fertilisation; it makes automatic watering more feasible, thus saving time and labour; and it allows soil to be fortified and stored for a later use or sold as pre-fertilised soil.

Although Dow have not yet priced the new fertiliser, they believe that it will be within the economic reach of potting soil formulators.

Midsil Devolatilisation Equipment

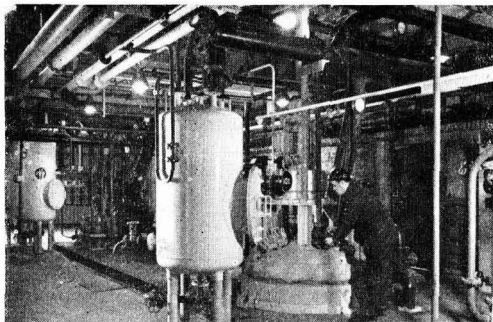

Devolatilisation equipment in the new silicone fluids plant at Midland Silicone's Barry factory. (See 'Project News', last week, p. 615)

Cutting Costs of Stainless Steel Flow Lines

PIPE helically welded from stainless steel or nickel alloy strip is produced in a process now in use by Welding Technical Services Ltd., Hurst Mill, Kings Norton, Birmingham 30. It is claimed that the new technique of producing pipe will so reduce the cost of flow line systems in stainless steel or nickel alloy that they will be competitive with mild steel installations.

Pipe is produced in bore sizes from 3-12 in. with wall thicknesses of 8-20 s.w.g., helical welding of the strip being carried out continuously and automatically to give pipe of unlimited length with crevice-free seams providing a clinically clean interior. Wall strength is stated to be considerably enhanced by the spiral weld; thus materials of lighter gauge may be used.

For complete installations, the helically welded pipe may be used in conjunction with the same company's Weltexa system, which includes bends, tee junctions, reducers and special joints and gaskets providing a complete installation ready for assembly by unskilled labour. The joints are designed to prohibit corrosion and do not have internal protrusions which would impede the normal flow line. The system makes use of a specially designed taft backed by a British Standard flange or to standards demanded by the American Standards Association. The new pipe will increase the flexibility of the system and the low cost of production will extend the range of stainless steel flow line systems.

Chemical Industry Speakers at RoSPA Conference

'Safety with solvents' is the title of a paper by Mr. J. Howlett, general manager of the Hull site of the Distillers Co. Ltd. and a director of the Chemical Division, to be given at this year's National Industrial Safety Conference at Scarborough, 12-14 May. The paper will be read in Mr. Howlett's absence by his colleague, Mr. K. Lazenby, general services manager of Distillers' Chemical Division. Another contribution to the conference will be a paper entitled 'Safety begins in the boardroom', by Mr. G. H. Beeby, chairman of British Titan Products Co. Ltd.

Chairman of the working sessions of the conference, which is organised by the Royal Society for the Prevention of Accidents, will be Mr. W. H. Harris, safety officer of Boots Pure Drug Co.

C.S. Anniversary Meeting

Three symposia (organic, inorganic and physical) will be arranged in conjunction with the anniversary meetings of the Chemical Society to be held in Sheffield during the period 3 to 5 April 1962. These are: 'Some aspects of the chemistry of natural phenols', 'Reactivity and structure in inorganic chemistry', and 'The transition state'. Full details of these symposia and of the anniversary meetings will be available in December 1961.



**IT'S A SMALL WORLD
AND MARCHON SURFACTANTS PLAY A BIG PART IN IT**

You don't need a little bird to tell you that. Ask any detergent manufacturer and he'll tell you that many of the best known detergents are formulated from Marchon surfactants.

SO₃ SULPHONATED DODECYL BENZENE

Now forms part of Marchon's range of dodecyl benzene sulphonates, and includes high purity sulphonic acids and their sodium salts with minimum inorganic content; especially suitable for liquid detergent formulations. Why not write for data, samples or advice?

Marchon

Commercial News

A.P.V. Co. Ltd.

Mr. W. E. Jenkins, chairman of the A.P.V. Co., reports that the current year's trading has started satisfactorily. Given no deterioration in the economic climate, the directors are hopeful of showing a moderate expansion of output and thus maintaining successful results.

Export activities in 1960 were again successful and about one-half of orders came from overseas. Total dollar sales advanced by 25%.

Mr. Jenkins attributes the improvement in results to an 11% rise in group turnover at £7.1 million, to greater productivity and to increased efficiency in all departments.

Wm. Butler and Co.

Group trading profit of Wm. Butler and Co. (Bristol) Ltd. for 1960 was £192,508, an increase of 12.3% on the 1959 figure of £171,376. Tax took £94,771 (£62,605), leaving a lower net profit, which stood at £97,737 (£108,771). Parent company's net profit was £80,172 (£91,163). £14,580 (£19,484) was retained by subsidiaries and £28,294 (£37,406) has been allocated to reserves. Final dividend is 7%, making 11% (10%). Annual meeting will be held on 16 June.

British Petroleum

Net sales of British Petroleum Co. Ltd. in 1960 were valued at £646,961,000 (£600,208,000), or 72.9 million tons (63.2 million). Pre-tax income was £144,477,000 (£130,958,000); tax took £82,199,000 (£67,498,000), leaving a net income of £62,278,000 (£63,460,000). A final dividend of 1s 8d is declared, making 2s 4d (2s 2d).

Dunlop Rubber

Group sales of the Dunlop Rubber Co. Ltd. in 1960 totalled £275 million (£261 million), while the net trading balance was £23,233,000 (£22,474,000). Net profit was £6,662,000 (£7,169,000). Depreciation took £8,124,000 (£7,339,000). Final dividend of 1s 3d (1s 2d) is declared, making 1s 7d (1s 6d).

Coalite and Chemical

Coalite and Chemical Products Ltd. have acquired all the issued share capital of Duramis Fuels Ltd., a private company carrying on business as manufacturers of oil additives.

Unilever Ltd.

In his annual report for 1960, Mr. George Cole, chairman of Unilever Ltd., states that supplies of detergent alkylate were adequate; tripolyphosphate was cheaper but prices of other chemicals showed little change. Unilever Group turnover totalled £1,846,839,000 (£1,787,197,000) of which soaps and other detergents (1,788,000 tons, against 1,787,000 tons in 1959) accounted for £304,407,000 (£308,031,000); this was 16% of total sales. Miscellaneous manufactures, including glycerine accounted

- Steep Tax Rise Hits Butler Net Profits
- Unilever Chemicals Sales Up, Profits Down
- B.A.S.F., Bayer Plan Capital Increases
- Ciba Plan Big Investments at U.K. Sites

for 5% of turnover at £88,169,000 (£80,668,000).

In spite of competition, sales of chemicals by Joseph Crosfield and Price's (Bromborough) were maintained, but profits were not up to the 1959 level.

Projects involving expenditure totalling £58 million were approved in 1960, including £764,000 for the third stage of factory reorganisation and extension at Warrington; £1,355,000 for facilities for the production of oleochemicals, including ozonisation and esterification plants at Gouda, Netherlands; £402,000 for fatty acid plant at Bromborough; and £248,000 for fatty acid plant at Emmerich, Germany.

Rio Tinto

Income, less expenditure, of the Rio Tinto Co. Ltd., excluding the Canadian group, for 1960 was £4,635,000 (£3,914,000). Tax took £1,611,000 (£1,216,000) leaving a balance of £3,024,000 (£2,698,000). A dividend of 2s 9d per unit is being paid (2s).

Anic-Gela

When the Anic-Gela Co. was set up to build large-scale petrochemical plants at Gela, Sicily, Societa' Finanziaria Siciliana (SOFIS) offered to contribute 25% of the new company's capital. Because of prior pledges, however, Anic-Gela have accepted only to the extent of 10%. SOFIS have agreed to this and will purchase Lire 3,000 million of shares out of a total Lire 30,000 m. The remaining Lire 9,000 million needed for the scheme will be obtained as follows: international loans, Lire 30,000 million; issue of bonds guaranteed by SOFIS, Lire 30,000 million (the issue of Lire 5,000 million worth of such bonds is already being studied); other sources, Lire 30,000 million.

B.A.S.F.

Badische Anilin- und Soda-Fabrik AG, propose a 1960 dividend of 18% (16%). The annual meeting on May 18 will further be asked to agree to a capital raise of DM100 million, to bring the B.A.S.F. capital up to DM800 million. The increase will be brought about by the issue (at 300% face value) of new shares at a rate of 1:7 in comparison with existing units. Permission is also to be asked for granted capital amounting to DM50 million and not to be used for 1961 investment purposes.

Farbenfabriken Bayer

In the first quarter of 1961, turnover of Farbenfabriken Bayer AG, Leverkusen, was 10% above the record level of 1960: exports accounted for 45% of sales in this period. Bayer's 1960 results were reported in CHEMICAL AGE, 15 April, p. 614. The level of the company's

capital after the capital increase expected in January next has not yet been fixed.

Bayer have denied recent Press reports that they were interested in the setting up in Egypt of an acrylic fibre plant. No large-scale investment projects are planned in the European Free Trade Association area. (See also 'Distillates').

Australian Chemical

A.C. Hatrick (N.Z.) Ltd., a subsidiary of Australian Chemical Holdings Ltd., are reported to be expanding their facilities.

Ciba AG

Ciba AG, Basle, report a 1960 turnover of S.Fr.1,130 million (£93.7 million), some 10% above the 1959 level of S.Fr.1,026 million (£84.8 million). Net profit rose from some S.Fr.27.3 million (£2.2 million) to over S.Fr.28.8 million (£2.4 million). Common Market countries took 26% of the total sales of the Ciba group and 30% of the mother company's sales, while E.F.T.A. members accounted for 19% of group sales and 26% of the Basle company's sales.

Financing of new plant and installations took 12% of total turnover, a rate expected to continue in the future. Over the current five-year investment programme some S.Fr.100 million (£8.25 million) will be invested by Ciba in the U.K. plants in Manchester, Duxford and Grimsby and Clayton Aniline's plant in Manchester.

Standard Oil (N.J.)

Standard Oil of New Jersey report a 1960 turnover of \$8,915 million, or 2% above the figure recorded for 1959. The rise in chemical sales is stated to have played a major part in the achievement of this level. Net profit per share rose over the year from \$2.93 to \$3.18.

INCREASES OF CAPITAL

SANDOZ AG, Basle, Switzerland, chemical and pharmaceutical producer. Capital to be increased from S.Fr.60 million to S.Fr.75 million by the issue of 30,000 new S.Fr.500 shares.

SOCIÉTÉ DES PRODUITS AZOTES, producers of nitrogenous fertilisers. Capital has been increased from Fr.15,828,600 to Fr.28,491,450. Face value of existing shares has been raised from Fr.50 to Fr.75 and a 1-for-5 scrip issue.

SOCIÉTÉ DES LABORATOIRES GEIGY, Paris. Increased from Fr. 6 million to Fr.7 million by a new issue for cash.

DON ALUM LTD. Cap. £100. Manufacturers of and dealers in aluminium sulphate, alumina, aluminium compounds, products and alloys, chemicals, etc. Subscribers: Alumina Co. Ltd., Iron Bridge Chemical Works, Widnes, Lancs; Peter Spence and Sons Ltd., 15 Norfolk Street, Manchester 2.

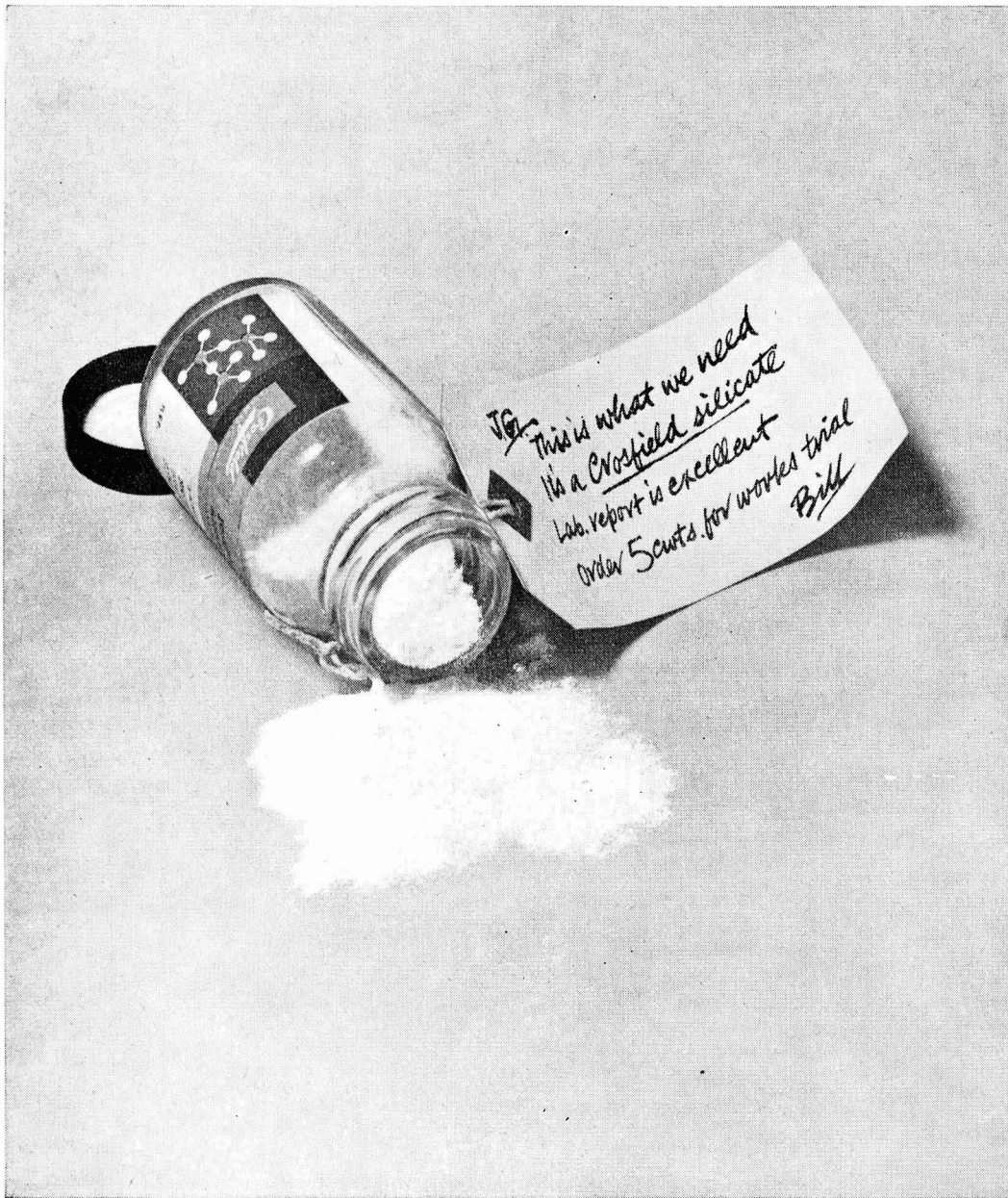

Have you considered using a silicate from the extensive Crosfield range? Whether you want to improve an existing product, develop a new one, save on material costs or simply solve a production problem, we may be able to help.

Crosfield silicates are already being widely used as extenders, reinforcing fillers, binding agents, deflocculators, suspending agents, adhesives and as desiccants in packaging.

Tell us your requirements and we'll send you a sample of the Crosfield silicate most suited to your specific job.

CROSFIELD MANUFACTURE SILICATES FOR INDUSTRIAL USES



JOSEPH CROSFIELD & SONS LTD · WARRINGTON · LANCASHIRE

TRADE NOTES

New I.C.I. Antioxidant

A new non-staining phenolic antioxidant, Topanol CA, has been developed by I.C.I.'s Heavy Organic Chemicals Division especially for polypropylene. Topanol CA in combination with dialuryl thiodipropionate, confers protection during the processing stages of polypropylene and subsequently imparts stability during fabrication and use.

Topanol CA alone can also be used as an antioxidant for polythene and outstanding protection is obtained in conjunction with dialuryl thiodipropionate. The compound may be of interest in other polymers, such as polyesters.

This antioxidant is being produced on a pilot plant scale and development quantities are now available.

Dyes for Terylene

A range of new dyes for Terylene and Terylene blends, known as the Esterophiles, are being marketed in the U.K. by the Alliance Dye and Chemical Co. Ltd., Lever Street, Bolton, Lancs. Developed by Compagnie Francaise des Matieres Colorantes (Francolor) of Paris, the new dyes are claimed to permit the permanent pleating or setting of Terylene fabrics without risk of the colours 'subliming'. They are also claimed to give attractive, bright shades with high light and colour fastness.

Isopropyl Alcohol

Prices of I.P.S. grades of isopropyl alcohol have been cut by Shell Chemical Co. Ltd. from 17 April. The new price schedules will result in reductions of about 2d. per gall. for 45 gall. drum deliveries and 4d. per gall. for bulk deliveries on I.P.S. 1, I.P.S. 2, and I.P.S. 3. These solvents were among the first chemicals to be produced by Shell from petroleum in the U.K.

Continuous Bleaching

A new continuous bleaching process that is claimed to cut manufacturing costs by up to 40% on natural and synthetic fibres has been developed by Olin Mathieson Chemical Corporation, U.S.

The process utilises Textone, one of Olin's sodium chlorite products which has hitherto been used mainly in batch operations. The new process, which requires little modification of conventional equipment, extends its use to the continuous bleaching of cotton, synthetic fabrics such as rayon, nylon, Acrilan and Daeron, and blends of natural and synthetic fibres. It is stated that savings in the sodium chlorite method over continuous peroxide bleaching are realised in material costs.

A technical bulletin describing the new process is available from Olin Mathieson Chemical Corporation, Sales Development Department, Chemicals Division, Baltimore 3, Md., U.S.

Change of Name

The name of Leda Chemicals Ltd. has been changed to Leda Pharmaceuticals Ltd. The company, which is a subsidiary of F. W. Berk and Co. Ltd., manufactures ethical products, mostly for the National Health Service, and Berk optical grade zinc bromide filling for radiotherapy windows. The filling allows perfect visual acuity and provides complete biological shielding. The company's extensive plant is in Edmonton, London N.18.

Tylox Tile-like Finish

Tylox, a brush-applied tile-like finish, is available from Tretol Ltd., London N.W.9. It is obtainable in a special grade with primers and undercoats for application to wood surfaces, in addition to the standard grades for all types of wall and ceiling surfaces. It is available in a range of colours and is designed to provide a tough, jointless finish which withstands extreme hard wear and washing.

Plastics Pipe for Water Services

British Standards for unplasticised p.v.c. and high density polythene pipe are now being considered by a British Standards Institution Committee for applications in pipes for cold water services and supply for industrial use. The drafts include recommendations for

the jointing of these pipes. The future possibilities of plastics in the field of hot water services are also being investigated. At present, the British Plastics Federation, which includes all the major material manufacturers, does not recommend the use of thermoplastics for applications involving the continual passage of hot water.

Metiram Safe as Agrichemical

Me'iram, a complex of zinc and polyethylene thiuramdisulphide, is recommended as a safe chemical for use in agriculture and horticulture in the U.K. It need not be included in the Agricultural (Poisonous Substances) Regulations. Metiram should present no hazard to operators provided certain simple precautions are observed and, on present information, its use on growing edible crop should present no hazard to consumers.

Ring Balance Meters

The full range of ring balance meters produced by Hagan Controls Ltd. for measuring and recording fuel flow is described and illustrated in a new brochure obtainable from the company, a member of the Plessey Group, at 14 Grosvenor Place, London S.W.1.

Non-ionic Thickeners

Featured recently in the O.C.C.A. Exhibition was Natrasol 250, hydroxyethyl cellulose, produced by Hercules Powder Co. Ltd., 1 Great Cumberland Place, London W.1. Natrasol 250 is a new non-ionic thickener for p.v.a. emulsion and other water-based paints. It is also finding increasing application as a stabilising colloid, binder and film former surface coating and adhesives.

DIARY DATES

MONDAY 24 APRIL

S.C.I.—London: 14 Belgrave Sq., S.W.1, at 6.30 p.m. 'Polymer science in the university' by Prof. G. Gee.
S.C.I.—Welwyn Garden City: Visit to British Rubber Producers' Research Assoc.

TUESDAY 25 APRIL

S.C.I.—London: 14 Belgrave Sq., S.W.1, 6.30 p.m. 'The rheology of concentrated polymer solutions' by Dr. A. S. Lodge.

I.Chem.E.—London: The Park Lane Hotel, Piccadilly, W.1, 39th A.g.m. & Annual Dinner & Dance.

S.C.I.—Liverpool: Gossage Theatre, Donnan Labs. Univ. of Liverpool, 6.15 p.m. A.g.m. of Oils and Fats Group & Application of gas chromatography to some medical problems' by Dr. A. T. James.

WEDNESDAY 26 APRIL

N.B.A.—London: Granville Ho., 132-135 Sloane St., S.W.1, at 2.30 p.m. A.g.m.

R.S.A.—London: John Adam Street, Adelphi, W.C.2, at 2.30 p.m. The Trueman Wood Lecture 'The training of scientists and engineers for industry' by Sir John Cockcroft.

S.A.C.—Birmingham: Main Chem. Lecture Theatre, The Univ., Edgbaston, at 7 p.m. 'Spectrofluorimetry' by Dr. C. A. Parker & 'Testaluminescence spectra' by Dr. R. J. Magee.

S.C.I.—London: 14 Belgrave Sq., S.W.1, 6.15 p.m. A.g.m. of Food Group, Nutrition Panel.

THURSDAY 27 APRIL

S.C.I.—London: 14 Belgrave Sq., S.W.1, 6 p.m. A.g.m. of Microbiology Group & 'Recent microbiology problems in industry' by H. J. Bunker.

FRIDAY 28 APRIL

S.A.C.—Carlisle: Central Hotel, Victoria Viaduct, 7.30 p.m. 'The determination of nitrates and the application of "dead-stop" titrimetry' by A. F. Williams & 'Ion-exchange resins as analytical tools' by Dr. T. R. E. Kressman.

S.C.I., **S.A.C.**, **R.I.C.**—Cardiff: Univ. Coll., Cathays Park at 7 p.m. 'Modern legislation in relation to food additives' by C. A. Adams.

First Metallic Corrosion Congress



A reception for overseas delegates to the 1st International Congress on Metallic Corrosion was held by H.M. Government at Lancaster House, London, last week. Here, left to right, are Dr. E. L. Streetfield (technical director, Houseman and Thompson Ltd.), chairman of the executive committee; Mrs. Streetfield; Lady Melville and Sir Harry Melville (secretary, D.S.I.R.), president of the congress

for **BULK SUPPLIES**

ACETONE

ATE ESTERS

ONE ALCOHOL

M.E.K

BUTANOL

H OLS

HALATES

• PATES

;



THE DISTILLERS COMPANY LIMITED • CHEMICAL DIVISION.

Bisol Sales Office

Devonshire House, Piccadilly, London, W.1. Telephone: Mayfair 8867

NEW PATENTS

By permission of the Controller, H.M. Stationery Office, the following extracts are reproduced from the "Official Journal (Patents)", which is available from the Patent Office (Sales Branch), 25 Southampton Buildings, Chancery Lane, London W.C.2., price 3s 6d including postage; annual subscription £8 2s.

Specifications filed in connection with the acceptances in the following list will be open to public inspection on the dates shown. Opposition to the grant of a patent on any of the applications listed may be lodged by filing patents form 12 at any time within the prescribed period.

AMENDED SPECIFICATIONS

On Sale 17 May

Organometallic compounds. National Lead Co. 793 354

ACCEPTANCES

Open to public inspection 17 May

Stable, aqueous ferruglycol sulphate complex solutions and process for the production thereof. Schwarz Arzneimittelfabrik GmbH. 868 321

Method of producing alkali metal terephthalate. Mitsubishi Chemical Industries Ltd. 868 338

Oxidation processes with chlorites. Solvay & Cie. [Addition to 640 394.] 868 339

Alcohol of improved odour from ether hydration. Esso Research & Engineering Co. 868 396

Distributing gas to fluidised beds. Esso Research & Engineering Co. 868 943

Modification of alkyd resins. Esso Research & Engineering Co. 868 574

Thiophosphoric acid esters. Shell Research Ltd. 868 575

Foamed plastics production. General Motors Corp. 868 272

Preparation of thiocarbonyl fluoride. Du Pont de Nemours & Co., E. I. 868 459

Isomerisation of saturated aliphatic carboxylic acid. Badische Anilin- & Soda-Fabrik AG. 868 324

Acetylene removal from hydrocarbon streams. Esso Research & Engineering Co. 868 297

Process for the preparation of N,N'-substituted ureas. Shell Internationale Research Maatschappij N.V. 868 460

Process for obtaining glutamic acid solution from beet sugar waste. Apinamoto So. Inc. 868 580

Organosilicon co-polymers. Midland Silicones Ltd. 868 188

Phenyl piperazine derivatives for therapeutic use and processes for the production of such derivatives. Soc. Industrielle pour la Fabrication des Antibiotiques. 868 353

Fractionation of cyclodiene monomer vapours. Esso Research & Engineering Co. 868 405

Method of alkylating aromatics. Esso Research & Engineering Co. 868 507

Method for producing stable tetraaminodiborons. United States Borax & Chemical Corp. 868 191

3-Mercaptoalkyl-3, 4-dihydro-1, 2, 4-benzothiazine-1, 1-dioxide derivatives. Abildgaard, K. [Divided out of 863 474.] 868 508

Reserpine compounds. Laboratoires Francais de Chimiotherapie. [Divided out of 868 477.] 868 487, 868 488

Cracking of olefins. Goodyear Tire & Rubber Co. 868 566

Treatment of effluents from coal carbonising plants. Gas Council. 868 567

Monoazo-pyrazole dyestuffs and their use. Geigy AG., J. R. [Addition to 844 427.] 868 474

Granulated fertiliser. Thyssen-Hütte AG, August. 868 155

Process for the acylation of polyoxymethylenes. Farbenfabriken Bayer AG. 868 356

Hindered tertiary amines in polymerisation of conjugated diolefins. Esso Research & Engineering Co. 868 531

Cross-linked polymers and copolymers of unsaturated β -diketones. Despica, A., and Kosanovic, D. [Divided out of 868 106.] 868 107

Open to public inspection 24 May

Treatment of distillery wastes. A.P.V. Co. Ltd. 869 059

Process for the purification of titanium tetrachloride. Laporte Titanium Ltd. 868 851

Treatment of ferrotitanium ores. Union Carbide Corporation. 868 717

Antibiotic designated A7907 and processes for its manufacture. Ciba Ltd. 868 972

Manufacture of nitric acid. Cathala, M. E. J. 869 062

Method for the purification and concentration of carboxylic acids. Benckiser GmbH, Job. A. 868 926

Heterocyclic monoazo dyestuffs and their chromium and cobalt complex compounds. Westminster Bank Ltd. [Addition to 835 470.] 869 031

Process for the manufacture of alumina enabling the use of low blast-furnace. Pechiney. 868 928

Lubricants. Ethyl Corp. 868 936

Methods for the production of polymers. Houilleres Bassin du Nord et du Pas de Calais. 868 855

Tertiary amine catalysts used in preparation of cellular polyurethane elastomers. General Tire & Rubber Co. 868 974

Calcium hypochlorite bleaching compositions. Olin Mathieson Chemical Corp. 869 004

Steroid compounds and process for their manufacture. Ciba Ltd. 868 975

Heterocyclically substituted steroids. Ciba Ltd. 869 007

Organic compounds of metals of group VI and production thereof. Monsanto Chemical Co. 868 650

Cyclic triaza- and tetra-aza compounds and light-sensitive silver halide emulsions containing them. Kodak Ltd. 868 786

Method of performing chemical, metallurgical and other industrial processes by means of an electric-glow discharge. Elektrophysikalische Anstalt B. Berghaus. 868 708

Polyazo-dyestuffs derived from 3,3'-dihydroxy-diphenylamine and process for their manufacture. Farbwerke Hoechst AG. 868 856

Epoxidation. Celanese Corp. of America. 868 890

Polyester moulding compositions comprising dextran or derivative. Commonwealth Engineering Co. of Ohio. 868 801

Forms of synthetic polymers and shaped structures therefrom and processes for their production. Du Pont de Nemours & Co., E. I. 868 651

Process for producing a sequestering composition from sucrose containing material. Union Starch & Refining Co. Inc. 868 802

3-Hydroxy-4-carboxyphenyl esters of copper phthalocyanine tetrasulphonic acids and a process for their manufacture. Durand & Huguenin AG. [Addition to 768 44.] 868 682

Production of polymers. Monsanto Chemical Co. 869 011

Process for the purification of titanium tetrachloride. Laporte Titanium Ltd. 868 851

Treatment of ferrotitanium ores. Union Carbide Corporation. 868 717

Antibiotic designated A7907 and processes for its manufacture. Ciba Ltd. 868 972

Manufacture of nitric acid. Cathala, M. E. J. 869 062

Method for the purification and concentration of carboxylic acids. Benckiser GmbH, Job. A. 868 926

Heterocyclic monoazo dyestuffs and their chromium and cobalt complex compounds. Westminster Bank Ltd. [Addition to 835 470.] 869 031

Process for the manufacture of alumina enabling the use of low blast-furnace. Pechiney. 868 928

Lubricants. Ethyl Corp. 868 936

Methods for the production of polymers. Houilleres Bassin du Nord et du Pas de Calais. 868 855

Tertiary amine catalysts used in preparation of cellular polyurethane elastomers. General Tire & Rubber Co. 868 974

Calcium hypochlorite bleaching compositions. Olin Mathieson Chemical Corp. 869 004

Steroid compounds and process for their manufacture. Ciba Ltd. 868 975

Heterocyclically substituted steroids. Ciba Ltd. 869 007

Organic compounds of metals of group VI and production thereof. Monsanto Chemical Co. 868 650

Cyclic triaza- and tetra-aza compounds and light-sensitive silver halide emulsions containing them. Kodak Ltd. 868 786

Method of performing chemical, metallurgical and other industrial processes by means of an electric-glow discharge. Elektrophysikalische Anstalt B. Berghaus. 868 708

Polyazo-dyestuffs derived from 3,3'-dihydroxy-diphenylamine and process for their manufacture. Farbwerke Hoechst AG. 868 856

Epoxidation. Celanese Corp. of America. 868 890

Polyester moulding compositions comprising dextran or derivative. Commonwealth Engineering Co. of Ohio. 868 801

Forms of synthetic polymers and shaped structures therefrom and processes for their production. Du Pont de Nemours & Co., E. I. 868 651

Process for producing a sequestering composition from sucrose containing material. Union Starch & Refining Co. Inc. 868 802

3-Hydroxy-4-carboxyphenyl esters of copper phthalocyanine tetrasulphonic acids and a process for their manufacture. Durand & Huguenin AG. [Addition to 768 44.] 868 682

Production of polymers. Monsanto Chemical Co. 869 011

Epoxide resin compositions. Bakelite Ltd. 868 733

Anti-corrosive or water-displacing compositions and their use. Geigy AG., J. R. 868 990

Tetra-halogen-hexahydro anthraquinones and process for the manufacture thereof. Ciba Ltd. 868 805

Preparation of glycidyl polyethers of polyhydric phenols. Union Carbide Corp. 868 861

Chlorination of zirconia-silica compounds. British Titan Products Co. 868 807

Benzimidazoles. Ciba Ltd. 868 864

Polyurethane resins. Petrochemicals Ltd. 868 996

Monoazo dyestuffs and the production of same. Badische Anilin- & Soda-Fabrik AG. 868 742

Antibiotics. Glaxo Laboratories Ltd. 868 958

Process for the production of fuel gas in carbon monoxide. Metallgesellschaft AG. 868 870

Production of esters. Imperial Chemical Industries Ltd. 869 001

Method of preparing compounds containing the grouping-NCI-CO-NCl- in a ring. Montecatini. 868 876

Cyclohexane compounds and process for making same. International Flavors & Fragrances Inc. 868 850

Dyestuffs of the tetra-azaporphin series and their production. Badische Anilin- & Soda-Fabrik AG. 868 917

9- α -Halosteroids. Searle & Co., G. D. 868 893

α -Amino acetophenone derivatives. Phillips Gloeilampenfabrieken N.V. 868 880

Aminonaphthol derivatives. Farbenfabriken Bayer AG. 868 884

Production of cumene hydroperoxide. Rhone-Poulenc. 868 907

Tertiary alkyl ferrocenes. Imperial Chemical Industries Ltd. [Addition to 828 965.] 869 058

Process for the production of eupolyoxymethylene. Deutsche Gold- und Silber-Scheideanstalt. 868 899

Production of ethylene polymers. Phillips Petroleum Co. 869 009

Chlorinated bicycloheptenes and fungicidal compositions containing them. Vesicol Chemical Corp. 868 910

Production of 4-methyl-1-pentene. Shell Internationale Research Maatschappij N.V. 868 945

Sulphanomides and process of making same. Boehringer & Soehne Industries Ltd. 868 947

Dyestuffs of the anthraquinone series and their production. Badische Anilin- & Soda-Fabrik AG. [Divided out of 868 741.] 868 744

Water-soluble monoazo dyestuffs and their production. Badische Anilin- & Soda-Fabrik AG. [Divided out of 868 741.] 868 745

Dyestuffs of the azaporphin series and their production. Badische Anilin- & Soda-Fabrik AG. [Divided out of 868 741.] 868 746

Production of water-soluble dyestuffs of the azaporphin series. Badische Anilin- & Soda-Fabrik AG. [Divided out of 868 741.] 868 747

Market Reports

COAL TAR PRODUCTS REMAIN STEADY

LONDON Home trade demand for industrial chemicals has been sustained for both contract deliveries and new bookings, and prices remain steady. The volume of enquiry for export has been satisfactory and spread over a wide range of chemicals. Among the soda products a good movement into consumption has been reported for chlorate of soda, bichromate and hyposulphite of soda. Fertilisers continue in strong request to meet seasonal requirements.

There has been little alteration in the firm position of most of the coal tar products with available supplies of naphthalene and pyridine finding a ready outlet.

MANCHESTER Trading conditions have shown little change and in most sections there has been a satisfactory movement of supplies against contracts

to the textile and allied industries and to other leading outlets. Steady deliveries of potash and soda compounds, bleaching powder, industrial solvents, hydrogen peroxide and a wide range of other products are being called for.

No price change of any consequence has occurred. In the market for fertiliser materials the top-dressing descriptions are meeting a seasonally brisk demand.

SCOTLAND Most sections of industry have returned to normal trading. Business has been on a satisfactory level although there is still a tendency to quietness in some sectors. Demands against contract requirements have been steady. Apart from some little variations, prices have also been steady.

The export market maintains a good volume of activity and a reasonable level is now being maintained in agricultural chemicals.

Buy British...

sodium chlorite

Now available from Britain's only manufacturer...

LAPORTE

LAPORTE CHEMICALS LIMITED LUTON · TEL: LUTON 4390



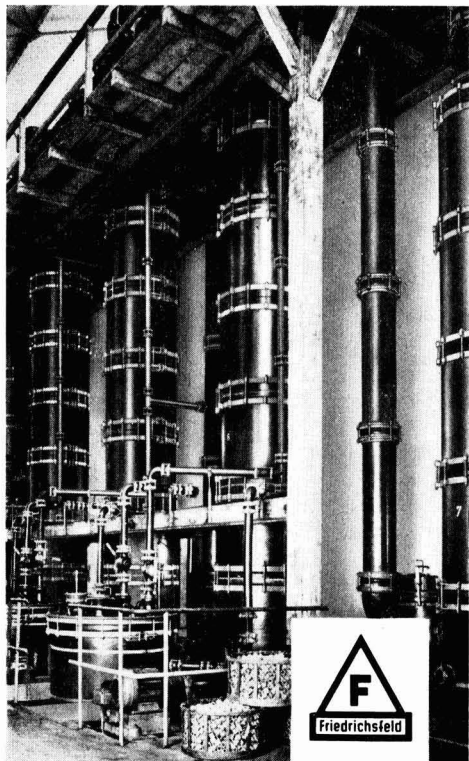

We supply products of:
STONEWARE,
 acid proof as well as temperature
 resistant,

TECHNICAL PORCELAIN,
SYNTHETIC RESIN, **SYNTHETIC CARBON**,
ELECTRO GRAPHITE

Installations, Apparatus & Equip-
 ment such as Columns, Bleaching
 Plants, Pumps, Exhausters, Heat-
 exchangers, Valves, Tubes, Vessels,
 Sinks, Filters, Rollers, etc., and
 equipment to customers' speci-
 fications.

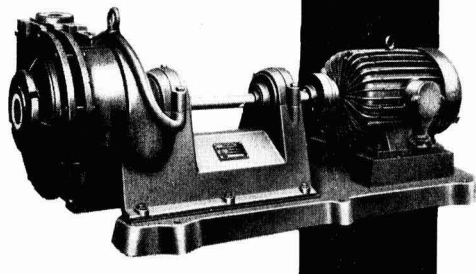

**DEUTSCHE STEINZEUGWARENFABRIK
 MANNHEIM-FRIEDRICHSFELD**

Sole representative:—

ANDERMAN & COMPANY LIMITED

BATTLEBRIDGE HOUSE, 87-95 TOOLEY STREET, LONDON, S.E. 1

Tel: HOP 0035 6 & HOP 1169. Telegraphic Address: Deran, Phone, London

CARRIERS OF

LIQUIDS IN BULK

ACIDS · OILS · SPIRITS
 AND GENERAL CHEMICALS

HAROLD WOOD & SONS LTD.

Wormald St. · Heckmondwike

Tel.: Heckmondwike 1011/5

Branch Office: Cranes Close, Nevendon Industrial Estate, Basildon, Essex.
 Telephone: Basildon 20511-2.

Decolorising **CARBON**

ALL GRADE
 FOR
 ALL TRADES

**HIGHEST EFFICIENCY
 LOWEST PRICES**

**Granular Carbon for Solvent Recovery
 Regeneration of Spent Carbon**

Write for samples and quotations.

FARNELL CARBONS LIMITED

CONDUIT ROAD, PLUMSTEAD, LONDON, S.E.18

Telephone:

Woolwich 1158 (2 lines)

Telegrams:

Scofar, Wol, London

Fire Prevention

Standard

Recommendations

THIS SYSTEM OF STANDARD RECOM-
 MENDATIONS for fire prevention was devised by
 the Kent County Brigade.

'..... streamlines paper work in the preparation of
 fire prevention reports'. **Municipal Journal**

'..... intelligent standardization of form and
 wording makes for more efficient work all round'

T.L.S.

8s. 6d. [postage paid]

Published by

ERNEST BENN LIMITED

Bouverie House · Fleet Street · London · EC4

CLASSIFIED ADVERTISEMENTS

CLASSIFIED RATES: All sections 5d. per word. Minimum 8/. Three or more insertions 4d. per word. Box Number 2/- extra.

SEMI-DISPLAY: 30/- per inch. Three or more insertions 25/- per inch.

BUSINESS OPPORTUNITIES

Indian Manufacturers are interested in exporting Sodium Dichromate, Sodium Sulphide, Chromic Acid and Aluminium Sulphate and Ferric. Enquiries should be addressed to **The Cawnpore Chemical Works Private Limited, Post Box 27, Kanpur, U.P., India.**

FOR SALE

600

MODERN ECONOMIC BOILERS

- 1—COCHRAN "Sinuflor" DOUBLE PASS 10' 9" dia. x 15' 8" over tubes evap. 16,800 to 18,000 lb/hr., 120 p.s.i., with chimney and i.d. fan.
- 1—JOHN THOMPSON treble pass 11' 0" dia. x 16' 0" over tubes, 14,500/15,000 lb/hr., 120 p.s.i. with i.d. fan.
- 4—EDWIN DANKS double pass 9' 9" dia. x 15' 6" over tubes, 12,000 lb/hr., 120 p.s.i. with i.d. fan, chimney, etc.
- 1—FOSTER YATES & THOM double pass 9' 9" x 15' 0" dia. x 15' 6" over tubes, 12,000 lb/hr., 160 p.s.i.
- 1—DANIEL ADAMSON treble pass 9' 9" x 15' 0" dia. x 15' 6" over tubes, 10,000 lb/hr., 160 p.s.i.

Other types of vertical and horizontal boilers always in stock.

**GEORGE COHEN
Sons & Co. Ltd.
Wood Lane, London, W.12.
(Shepherds Bush 2070)
Stanningley, Nr. Leeds
(Pudsey 2241)**

Baker-Perkins VACUUM MIXERS with Steam Heated Naben Blades and Troughs. Two 33 in. by 39 in. by 28 in. with 35 H.P. Three 21 in. by 21 in. by 20 in. with 12 H.P. Two 16 in. by 16 in. by 14 in. with 9 H.P. Drives. Lying: WILLOW TREE WORKS, Swallowfield, Berks.

Apply: **WINKWORTH MACHINERY LTD.,
65 High Street, Staines.
Telephone 55951**

FOR SALE: continued

1,200 KILOS of pure Barium Carbonate packed in 50 kilo kegs with
Fe 2 ppm, Pb less than 5 ppm, Ni 2 ppm, Cu 2 ppm, at less than 1 ppm.
Offers to **Box 3749, Chemical Age.**

MATERIALS WANTED

WANTED

Scrap Electrode Carbons, Graphite Offcuts, etc.

send samples and details of tonnage available to

**FINE GRINDING LTD.,
Blackhole Mine, Eyam, Derby
phone Eyam 227**

PLANT AND MACHINERY FOR SALE

Baker-Perkins Class BB "Double Naben" Bladed Steam Jacketed Mixers. Four—size 12 and Three—size 11, of 20 and 8 gallons respectively.

Oil Jacketed Double Trough Mixer 48 in. by 36 in. by 29 in. deep. Paddle Blades. Bottom Outlets.

Barron 'U' Sifter Mixer 96 in. by 33 in. by 33 in. with 10 H.P. A.C. Motor.

Gardner 'U' Sifter-Mixers 66 in. by 24 in. by 24 in. with 5 H.P. A.C. Motors. Four available, of modern streamlined design.

Horizontal 'U' Trough Mixers 48 in. by 18 in. by 22 in. Three—Tilting type, Paddle Blades. Glanded.

Over-Arm Twin-Blade, Tilting, 30 gallon Mixers with 3 H.P. Geared Motors. Five available.

Lying at our No. 2 Depot, Willow Tree Works, Swallowfield, Berkshire.

Apply: **Winkworth Machinery Limited, 65 High Street, Staines, Middlesex. Telephone 55951.**

Phone 55298 Staines

Stainless Steel Jac. Cyl. Mixers 50, 100 & 150 gallons.

Stainless Steel Vac. 'Z' blade Mixer 3 ft. by 3 ft. by 3 ft., 40 h.p. A.C. "Steelshaw" Porcelain Lined Ball Mills, 4 ft. by 3 ft. & 5 ft. by 4 ft. dia.

Enamel lined Jac. Reactors 2 ft. 6 in. by 3 ft. dia.

(3) 10,000 gall. Welded Steel Cyl. Enc. Tanks.

"Johnson" Jac. Filter Press, 8 plates, 9 frames 25 in. sq.

"Johnson" Lab. Filter Press, 4 plates 5 frames 9 in. sq., with pump. Steel Cased Fan 18 in. inlet *Water Cooled Bearings*, 12½ h.p. A.C. 24 in. dia. "Flameproof" Axial Flo Fan, 2 h.p. 400/3/50.

Send for Lists

**HARRY H. GARDAM & CO. LTD.,
100 CHURCH STREET, STAINES**

PLANT AND MACHINERY FOR SALE: continued

Three Lead lined STEEL TANKS, 14,000 galls., 9 ft. diam. by 35 ft. long.

Three Lead lined STEEL TANKS, 9,500 galls., 13 ft. 6 in. diam. by 10 ft. high.

Two NICKEL SILVER TANKS, 6,750 galls., 8 ft. diam. by 23 ft. 3 in.

Brand New COCHRAN Vertical and ECONOMIC Self-contained STEAM BOILERS in stock, also all sizes reconditioned and guaranteed. List on request.

STAINLESS STEEL TANKS, PANS, CONDENSERS, PLATES, VALVES AND COCKS. Very wide selection.

FRED WATKINS (ENGINEERING) LTD.,

COLEFORD, GLOS.

Phone: Coleford 2271/2.

*SITUATIONS VACANT***GRADUATE CHEMISTS**

STOREYS OF LANCASTER have vacancies in their Development Department for qualified Chemists.

The Company manufactures P.V.C. sheeting for many varied domestic and industrial uses and the importance of Development is fully recognised.

The Head Office and Works are in Lancaster, north of Lancashire's industrial belt and within easy reach of pleasant residential areas.

Conditions of employment include a five-day week, and a contributory Superannuation Fund.

High calibre chemists are required and a good class honours degree is essential. Post-graduate research and industrial experience will be welcome, as will applications from Chemists who will graduate later this year.

Applications in the strictest confidence should be addressed to the Personnel Manager, Storey Brother and Company Limited, White Cross, Lancaster.

DEVELOPMENT ENGINEER

required for interesting and varied work in Development Laboratory of expanding Chemical Engineering company. Applicants should have H.N.C. or equivalent and preferably some practical knowledge of heat transfer and fluid flow. Salary commensurate with qualifications and experience. The position is superannuated. Apply: Chief Engineer, Powell Duffryn Carbon Products Limited, Springfield Road, Hayes, Middlesex.

WANTED

WANTED.—Scrap Graphite either new or used. Current price offered approximately £10/12 ex works in minimum 1 ton lots. Please submit samples. Box 3746, Chemical Age.

WORK WANTED & OFFERED

CRUSHING, GRINDING, MIXING and DRYING for the trade
THE CRACK PULVERISING MILLS LTD.

Plantation House,
Mincing Lane,
London, E.C.2

PULVERISING of every description of chemical and other materials. Collections, storage, deliveries. THOMAS HILL-JONES, LIMITED, INVICTA WORKS, BOW COMMON LANE, LONDON, E.3. (TELEPHONE: EAST 3285.)

**NOW
AVAILABLE**

1961
Chemical Age
DIRECTORY
and
WHO'S WHO

Steel Drums
Fibre Drums
Plastic Containers
for the Chemical Industry

METAL CONTAINERS LTD

KEYMOUR HOUSE 17 WATERLOO PLACE PALL MALL
LONDON S.W.1
WORKS: ELLESMERE PORT, RENFREW, CRAYFORD, MANCHESTER

—an invaluable work of reference to all concerned with the manufacture or use of chemicals, chemical engineering and chemistry.

The 1961 edition has been revised and considerably increased in size. In addition to a Who's Who section which contains biographical details of over 4,000 leading personalities in Chemicals, Chemical Engineering and Chemistry, and a Buyers' Guide listing the manufacturers and suppliers of more than 4,000 chemicals and items of chemical processing equipment, it includes a **completely new feature on the structure of the chemical industry entitled "Who Owns Whom"**.

Copies are available at £2 2s. 0d. each.

For further details please write:

CHEMICAL AGE

Bouverie House,

154 FLEET STREET, LONDON, E.C.4

or telephone:

FLEET STREET 3212

Chemical Age Enquiry Service

For fuller details of equipment, apparatus, chemicals etc., in the advertisement or editorial page of Chemical Age, fill in the coupons below, ONE PER ENQUIRY, and return to us.

<p><i>Please send further details about</i></p> <p>.....</p> <p>.....</p> <p><i>mentioned on page</i> <i>of this issue.</i></p> <p><i>Name</i> <i>Position</i></p> <p><i>Firm</i></p> <p><i>Address</i></p> <p>.....</p> <p>Chemical Age Enquiry Service.</p>
<p><i>Please send further details about</i></p> <p>.....</p> <p>.....</p> <p><i>mentioned on page</i> <i>of this issue.</i></p> <p><i>Name</i> <i>Position</i></p> <p><i>Firm</i></p> <p><i>Address</i></p> <p>.....</p> <p>Chemical Age Enquiry Service.</p>
<p><i>Please send further details about</i></p> <p>.....</p> <p>.....</p> <p><i>mentioned on page</i> <i>of this issue.</i></p> <p><i>Name</i> <i>Position</i></p> <p><i>Firm</i></p> <p><i>Address</i></p> <p>.....</p> <p>Chemical Age Enquiry Service.</p>

★ *Detach this page complete then fold as marked overleaf to use the post-paid reply folder*

Chemical Age

ENQUIRY SERVICE



☐ *This is a special service for readers of*

CHEMICAL AGE

☐ *It is designed to give fuller information on equipment, apparatus, chemicals etc., mentioned in this issue—whether in the editorial text or in an advertisement*

☐ *Cut out the whole of this page, fold as instructed with post-paid address on the outside*



Chemical Age

154 Fleet Street, London, E.C.4

Tel.: Fleet Street 3212

2nd FOLD

Postage
will be
paid by
the
Licensee

No Postage
Stamp
necessary if
posted in
Great Britain
or
Northern Ireland

BUSINESS REPLY FOLDER
Licence No. 2501

CHEMICAL AGE
154-160 FLEET STREET
LONDON, E.C.4

1st FOLD

3rd FOLD

CUT ALONG THIS DOTTED LINE

Fabrications for
the chemical industry
in mild steel,
stainless steel,
aluminium etc. by

YEWCO

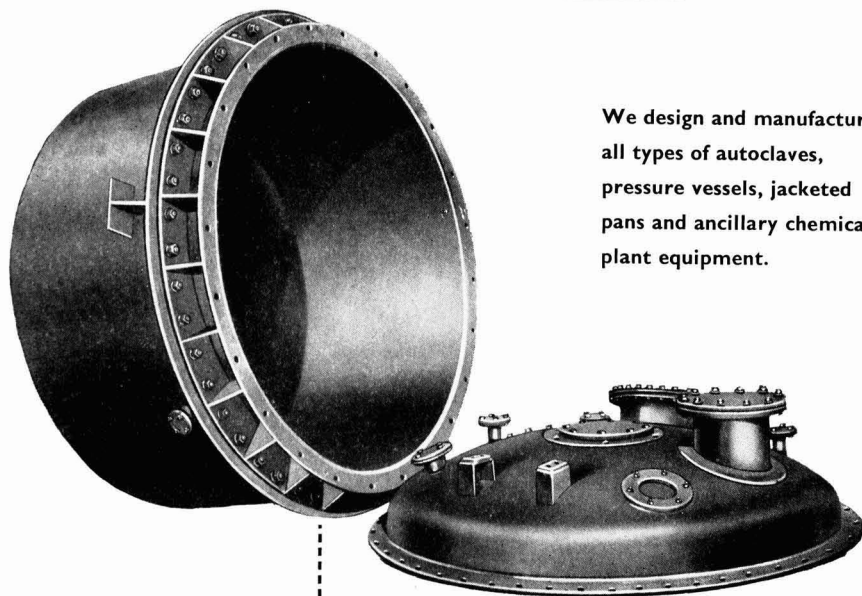

We design and manufacture
all types of autoclaves,
pressure vessels, jacketed
pans and ancillary chemical
plant equipment.

Typical 650 gal. stainless
steel pressure vessel, suit-
able for 50 lbs. p.s.i.

THE YORKSHIRE ENGINEERING & WELDING CO. (BRADFORD) LTD.,
FRIAR'S WORKS, BRADFORD ROAD, IDLE, BRADFORD

Tel: IDLE 470

FIRST FIND THE RIGHT PEOPLE

A leading technical college chose TRF, the Stainless Steel specialists, to build this Fermentor. Why TRF?

Because, very sensibly, they preferred to deal with the specialists . . . the people with the right solution to Stainless Steel problems. Stainless Steel could be playing a major part in *your* new plant. Much better speak to the right people about it . . . TRF.

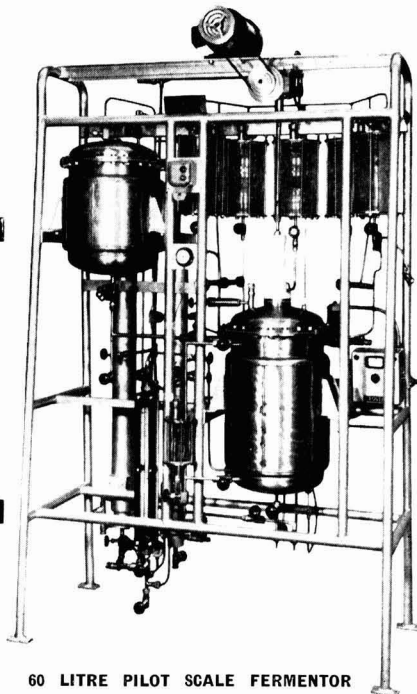

60 LITRE PILOT SCALE FERMENTOR
WITH MEDIUM PREPARATION VESSEL
AND GLASS ADDITIONAL VESSELS.

TAYLOR RUSTLESS FITTINGS CO LTD



HEAD OFFICE: RING ROAD, LOWER WORTLEY, LEEDS
Tel: LEEDS 638711
LONDON OFFICE: 14 GREAT PETER ST. LONDON, W.1
Tel: Abbey 1576

MIXING VESSELS

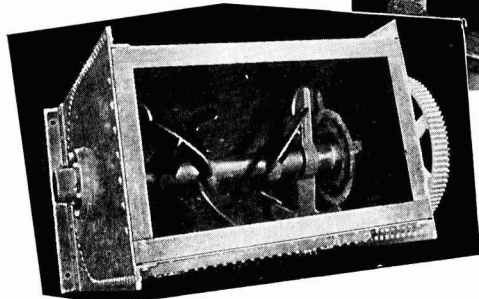
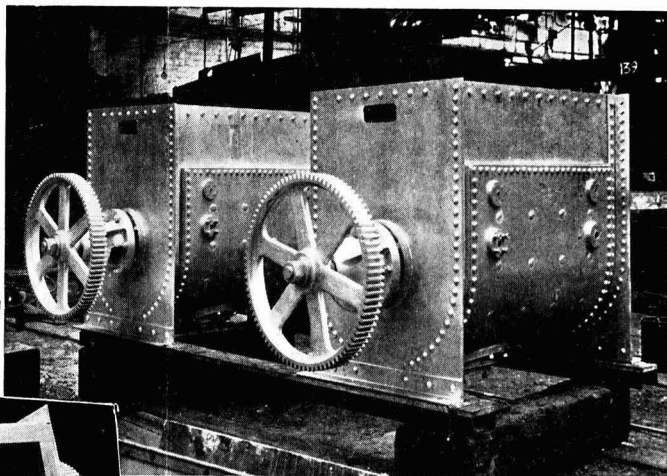

These hot water jacketed Mixing Vessels (capacity $\frac{1}{2}$ Ton each) are for use in chocolate manufacture. The lower photograph shows the stirring gear.

• • •

We manufacture Mixers, Blenders and Process Vessels for a wide range of Industries and applications.

POTT, CASSELS & WILLIAMSON LTD • MOTHERWELL • SCOTLAND
A Member of THE MIRRLEES WATSON GROUP