

Chemical Age

incorporating

PETROCHEMICALS and POLYMERS

VOL. 85 No. 2184

20 MAY 1961

**FOR
HIGH
QUALITY
BORON
PRODUCTS
20 MULE TEAM**

KOPPFERS COMPANY, INC.
Research Department

JUN - 5 1961

TIB
LIBRARY



Dehybor **ANHYDROUS BORAX** **Boric acid**

Boron products bearing the 20 MULE TEAM symbol are backed by the technical services of a world-wide group of companies whose constant research is yielding new and improved boron materials to match modern techniques.

20 MULE TEAM and DEHYBOR are Registered Trade Marks

**BORAX
CONSOLIDATED
LIMITED**

BORAX HOUSE
CARLISLE PLACE
LONDON SW1
Tel: VICTORIA 9070

แผนกห้องสมุด กรมวิทยาศาสตร์
กระทรวงอุตสาหกรรม

TGA 2184



NOW!

‘Queensway’

Polythene Liners for the Chemical Industry

from Europe's largest maker of Polythene film

Now you can get polythene liners under the trade name 'Queensway', tailored for you by British Visqueen Ltd., the largest producer of polythene film in Europe.

What does this mean to you in the chemical industry?

Simply that the accumulated "know how", and the up-to-date equipment of British Visqueen are now geared to provide you with a comprehensive service for the design and supply of liners for all types of chemical containers.

EXPERT PACKAGING SERVICE

British Visqueen have been the acknowledged experts on polythene film packaging for many years: they are the people who solve problems for packaging experts. They ensure the selection of the correct grade of polythene film, to be tailor-made into the ideal 'Queensway' liners for your products.



PROMPT DELIVERY Because of British Visqueen's modern equipment and large productive capacity, you can be sure of getting the right liners right on time, when you order 'Queensway' liners.

RELIABLE PROTECTION PLUS EFFECTIVE SEALING

'Queensway' liners offer you a thoroughly reliable means of sealing off pastes and hygroscopic powders of all types from their outer containers and protecting them in transit and during storage. Being made from British Visqueen's polythene film, they are resistant to most highly corrosive substances, completely moisture proof, chemically inert, extremely tough and easily sealed.



For a complete liner design and supply service that will pay you dividends in quicker handling and improved protection for your products, use 'Queensway' liners.

BRITISH VISQUEEN LIMITED

A SUBSIDIARY COMPANY OF IMPERIAL CHEMICAL INDUSTRIES LIMITED

QW 169
BRITISH VISQUEEN LIMITED · SIX HILLS WAY · STEVENAGE · HERTS · TELEPHONE: STEVENAGE 1310



**GLASS IS RESISTANT
TO MORE CHEMICALS
THAN ANY OTHER
MATERIAL**

**ACHEMA
EXHIBITION**

Don't forget when
you're weary there
is always a cup of
tea and a seat on:

STANDS

A & B, 15-18
C & D, 13-16

Q.V.F. LTD., THE CHEMICAL ENGINEERS IN GLASS, DUKE ST., FENTON, STOKE-ON-TRENT, STAFFS. Phone: Stoke-on-Trent 32104

INDEX TO ADVERTISERS

The first figures refer to advertisements in Chemical Age Directory & Who's Who, the second to the current issue

<i>Page</i>	<i>Page</i>	<i>Page</i>	<i>Page</i>	<i>Page</i>	<i>Page</i>
		Brough, E. A., & Co. Ltd.	799		E.C.D. Ltd.
		Brown, N. C., Ltd.	—		Electric Resistance Furnace Co.
		Bryan Donkin Co. Ltd., The	—		Electro-Chemical Engineering Co. Ltd.
164	Acalor (1948) Ltd.	Bulk Liquid Transport Ltd.	—		Electrothermal Engineering Ltd.
	African Pyrethrum Technical Information Centre	Bulwark Transport Ltd.	—		Elga Products Ltd.
148	Aimer Products Ltd.	Burnett & Rolfe Ltd.	—	Book	Mark Elliott, H. J., Ltd.
121	Air Products Gt. Britain Ltd.	Bush, W. J., & Co. Ltd.	—		Elliott Brothers (London) Ltd.
	Air Trainers Link Ltd.	Butterfield, W. P., Ltd.	—	145	Elmatic
	Aiton & Co. Ltd.	Butterworths Scientific Publications	—		Evans Electro Selenium Ltd.
147	Albany Engineering Co. Ltd., The		—		
155	Alginate Industries Ltd.	Callow Rock Lime Co. Ltd., The	—		
123	Allen, Edgar, & Co. Ltd.	& 249 Calcic Engineering Co. Ltd.	—	168	Farnell Carbons Ltd.
	Allen, Frederick & Sons (Poplar) Ltd.	Carless, Canel, & Leonard Ltd.	802	156	Feltham, Walter H., & Co. Ltd.
	Allis-Chalmers Great Britain Ltd.	Causeway Reinforcement Ltd.	—	152	Ferris, J. & E., Ltd.
160	Alumina Co. Ltd., The	Chappell, Fred, Ltd.	—	279	Ferrostatics Ltd.
	Ancorite Ltd.	Chemical Age Enquiries	833 & 834		Filden Electronics Ltd.
	Andrew Air Conditioning Ltd.	Chemical & Insulating Co. Ltd., The	—	171	Flight Refuelling Ltd.
136	Anglo-Dal Ltd.	Chemicals & Feeds Ltd.	—		Fireproof Tanks Ltd.
	Anthony, Mark, & Sons Ltd.	Chemolimpex	—	185	Foxboro-Yoxall Ltd.
211	Armour Hess Chemicals Ltd.	Christy & Norris Ltd.	—		Freeman, William, & Co. Ltd.
	Ashmore, Benson, Pease & Co. Ltd.	Giba (A.R.L.) Ltd.	—	207	Fullers' Earth Union Ltd., The
	Associated Electrical Industries Ltd.	Giba Clayton Ltd.	—		
	Motor & Control Gear Division	Ciech Ltd.	—		
	Associated Electrical Industries Ltd.	Citenco Limited	—	122	G.O. Parachute Co. Ltd.
153	Turbine-Generator Division	Classified Advertisements	828, 831 & 832	168	Gallenkamp, A., & Co. Ltd.
	Associated Lead Mfrs. Ltd.	Clayton, Son & Co. Ltd.	—		Gascoigne, Geo. H., Co. Ltd.
G/Card	Audco Limited	Clydesdale Chemical Co. Ltd.	—		Geigy Co. Ltd., The
		Cohen, George, Sons & Co. Ltd.	—	183	General Precision Systems Ltd.
	B.S.A. Small Tools Ltd.	Cole, R. H., & Co. Ltd.	—		Glass Manufacturers' Federation
179	Baker Perkins Ltd.	Colt Ventilation Ltd.	—		Giusti, T., & Sons Ltd.
173	Balfour, Henry, & Co. Ltd.	Comet Pump & Eng. Co. Ltd., The	—		Glebe Mines Ltd.
182	Barclay Kellett & Co. Ltd.	Commercial Plastics Ltd.	—		Goodyear Pumps Ltd.
138	Barytes (Shielding Products) Ltd.	Consolidated Zinc Corporation Ltd.	—	167	Graviner Mfg. Co. Ltd.
	Begg, Coussland & Co. Ltd.	Constable & Co. Ltd.	—	172	Greeff, R. W., & Co. Ltd.
128	Belliss & Morcom Ltd.	G/Card	Constantin Engineers Ltd.	797	
165	Bennett, Sons & Sheats Ltd.	Constructors John Brown, Ltd.	—		Halex (Bex Industrial)
G/Card	Berk, F. W., & Co. Ltd.	Controlled Convection Drying Co.	—	144	Haller & Phillips Ltd.
3	Black, B., & Sons Ltd.	Cooke, Troughton & Simms Ltd.	—		Hamilton Company Inc.
	Blackman, Keith, Ltd.	Coulter Electronics Ltd.	—		Harris (Linstock Gramam) Ltd.
	Blaw Knox, Chemical Engineering Co. Ltd.	Cromil & Piercy Ltd.	794	156	Harvey, G. A., & Co. (London) Ltd.
190	Blundell & Crompton Ltd.	Crosfield, Joseph, & Sons Ltd.	—	6	Haworth, F. (A.R.C.) Ltd.
	Boby, William, & Co. Ltd.	Crow Carving Co. Ltd., The	794		Heafield Industries Ltd.
	Borax & Chemicals Ltd.	Cruickshank, R., Ltd.	—		Hearson, Charles, & Co. Ltd.
205	Borax Consolidated Ltd.	Curran, Edward, Engineering Ltd.	—		Helmets Ltd.
4	Boulton, William, Ltd.	Cyanamid of Great Britain Ltd.	—	161	Hercules Powder Co. Ltd.
	Braby, Frederick, & Co. Ltd.	Cyclo Chemicals Ltd.	—	164	Hinde, Joshua, & Sons Ltd.
265	Brackett, F. W., & Co. Ltd.	126 Cyclops Engineering Co. Ltd., The	—	151	Holden, Chris., Ltd.
	British Acheson Electrodes Ltd.		—		Huntingdon, Heberlein & Co. Ltd.
132	British Carbo Norit Union Ltd.		—		
	British Ceca Co. Ltd., The	235 Dalglish, John, & Sons Ltd.	—		
193	British Celanese Ltd.	152 Danks of Netherpton Ltd.	—		
	British Drug Houses Ltd., The	Davenport Engineering Co. Ltd.	—		
154	British Ermeto Corporation Ltd.	136 Davey & Moore Ltd.	—		
Spine	British Geon Ltd.	144 Davey, Faxman & Co. Ltd.	—		
271	British LaBour Pump Co. Ltd.	140 Dawson, McDonald & Dawson Ltd.	—		
	British Lead Mills Ltd.	Deutsche Steinzeugwarenfabrik	794		
	G/Card	143 Distillers Co. Ltd., The	—		
	British Oxygen Company Ltd. (Heavy Industrial Dept.)	139 Distillers Co. Ltd., The (Chemical Div.)	829		
146	British Rototherm Co. Ltd., The	Distillers Co. Ltd., The (Industrial Group)	—		
122	British Steam Specialties Ltd., The	135 Dorr-Oliver Co. Ltd.	—		
126	British Tar Products Ltd.	131 Doulton Industrial Porcelains Ltd.	—		
	British Thomson-Houston Co. Ltd., The	154 Dowling Lime & Stone Co. Ltd.	—		
	G/Card	Dow Chemical International S.A.	—		
	British Titan Products Co. Ltd.	Dryden, T., Ltd.	—		
	British Visqueen Ltd.	Dunlop Rubber Co. Ltd. (G.R.G. Dunclad)	—		
321	Broadbent, Thomas, & Sons Ltd.		—		
163	Brotherhood, Peter, & Co. Ltd.		—		

(Continued on page 786.)

FOR ANTIMONY CHLORIDE SOLUTIONS

CONSULT

FREDERICK ALLEN & SONS (POPLAR) LTD.

PHOENIX CHEMICAL WORKS, UPPER NORTH STREET, LONDON, E.14.

Telephone: EAST 2673 (5 lines)

Cables: NITRIC, POP, LONDON

OIL...

Immense quantities of Hydrochloric Acid are required yearly in the Middle East for processing crude oil. To allow the acid to be carried in complete safety as deck cargo, special tanks of 500 gallon capacity fabricated in our works and lined with plied Vulcoferran and Nordac acid resisting rubber, are supplied to

**B P TRADING LTD.,
IRAQ PETROLEUM CO. LTD.**

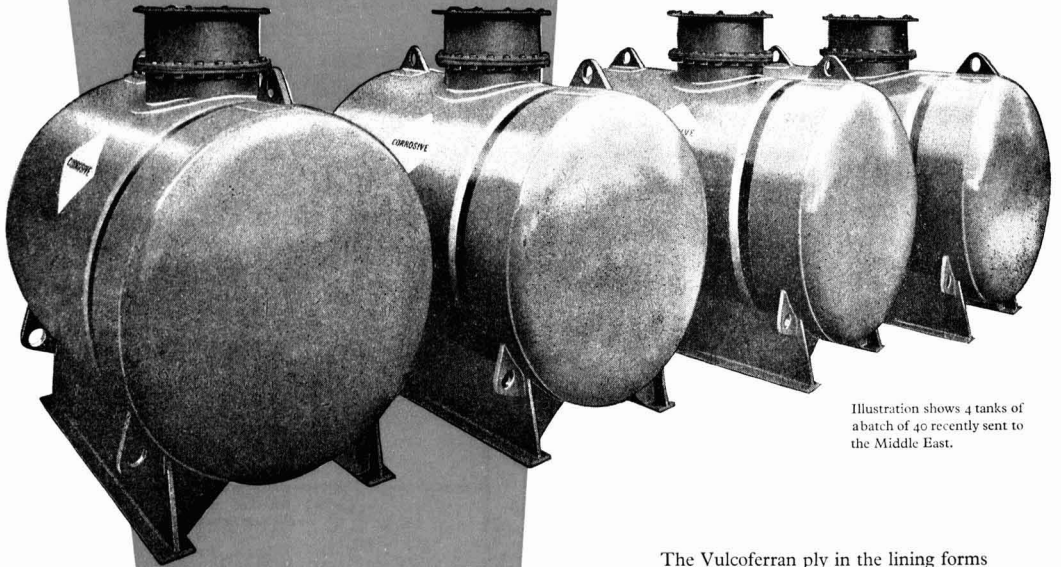

Illustration shows 4 tanks of a batch of 40 recently sent to the Middle East.

HCl and

The Vulcoferran ply in the lining forms an inseparable bond with the base metal and with the rubber: due to its flexibility and resistance to fluctuating temperatures, it ensures an enduring lining in all conditions. Vulcoferran could have a similar, or widely different application for you. Why not consult our Technical Advisory staff?

NORDAC

CHEMICAL ENGINEERS

NORDAC LIMITED · UXBRIDGE · MIDDLESEX Telephone: UXBRIDGE 35131-4

A MEMBER OF THE WOODALL-DUCKHAM GROUP OF COMPANIES

INDEX TO ADVERTISERS

The first figures refer to advertisements in Chemical Age Directory & Who's Who, the second to the current issue

Page	Page	Page	Page	Page	Page
174	Jackson, J. G., & Crockett Ltd.	—	National Industrial Fuel Efficiency Service	—	Shell Chemical Co. Ltd.
172	Jamesales Ltd.	—	118 Neckar Water Softener Co. Ltd.	—	Shell-Mex & B.P. Ltd.
—	Jenkins, Robert, & Co. Ltd.	—	149 Negretti & Zambra Ltd.	—	Shell Industrial Oils
—	Johnson, Matthew & Co. Ltd.	—	—	—	Shirley, Aldred, & Co. Ltd.
128	Johnsons of Hendon Ltd.	—	—	—	Siebe, Gorman & Co. Ltd.
—	Jones & Stevens Ltd.	—	Back Cover Newton Chambers & Co. Ltd.	—	197 Silvercrown Limited
—	—	—	Nordac Ltd.	785	157 Simon, Richard, & Sons Ltd.
186	K.D.G. Instruments Ltd.	—	Normalair Ltd.	—	Sipon Products Ltd.
—	K & K Laboratories Ltd.	—	Northgate Traders (City) Ltd.	—	Sojuzchimexport
170	K.W. Chemicals Ltd.	—	Nuovo Pignone	—	267 Southern Analytical Ltd.
—	Kaylene (Chemicals) Ltd.	—	—	—	Spence, Peter, & Sons Ltd.
198	Kellie, Robert, & Sons Ltd.	—	162 Odoni, Alfred A., & Co. Ltd.	—	199 Spencer Chapman & Messel Ltd.
—	Kellogg International Corporation	—	190 Optical-Mechanical (Instruments) Ltd.	—	223 Standard Chemical Co.
180	Kenton Fluorescent Mfg. Co.	—	Orthos (Engineering) Ltd.	—	320 Stanton Instruments Ltd.
166	Kernick & Son Ltd.	—	Otford Paper Sack Co. Ltd.	—	Staveley Iron & Chemical Co. Ltd.
319	Kestner Evaporator & Engineering Co. Ltd.	—	—	—	182 Steel Drums Ltd.
—	Kestner Evaporator & Engineering Co. Ltd.	828 & 830	G/Card P.G. Engineering Ltd.	—	196 Steel, J. M., & Co. Ltd.
—	(Keebush)	—	Palfrey, William, Ltd.	—	196 Sturge, John & E., Ltd.
—	Klinger, Richard, Ltd.	—	Penrhyn Quarries Ltd.	—	Super Oil Seals & Gaskets Ltd.
—	—	—	215 Permutit Co. Ltd., The	—	Surface Protection Ltd.
—	Laboratory Apparatus & Glass Blowing Co.	—	G/Card Petrocarbon Developments Ltd., The	—	192 Synthite Ltd.
—	Laboratory & Electrical Engineering Co.	—	188 Petroderivatives Ltd.	—	—
176	Laboratory Glassblowers Co.	—	Pickfords Limited	—	191 Taylor Rustless Fittings Co. Ltd.
—	Langley Alloys Ltd.	—	Pickstone, R. E., Ltd.	796	194 Thermal Syndicate Ltd., The
124	Lankro Chemicals Ltd.	—	Plastic Constructions Ltd.	—	Tidy, S. M. (Haulage) Ltd.
G/Card	Laporte Chemicals Ltd.	—	140 Plastic Filters Ltd.	—	156 Titanium Metal & Alloys Ltd.
—	Laporte Industries Ltd.	—	184 Platon, G. A., Ltd.	—	Todd Bros. (St. Helens & Widnes) Ltd.
134	Leek Chemicals Ltd.	—	Podmores (Engineers) Ltd.	—	168 Towers, J. W., & Co. Ltd.
176	Leigh & Sons Metal Works Ltd.	830	257 Polypenco Ltd.	—	261 Tylores of London Ltd.
—	Lennig, Charles & Co. (Great Britain) Ltd.	—	251 Polyplus Ltd.	—	—
—	Lennox Foundry Co. Ltd.	—	195 Pool, J. & F., Ltd.	—	Uhde, Friedrich, GmbH
181	Lind, Peter, & Co. Ltd.	—	Pott, Cassels & Williamson Ltd.	798	180 Unicone Co. Ltd., The
—	Lloyd & Ross Ltd.	Cover iii	Potter, F. W., & Soar Ltd.	—	200 Unifloc Ltd.
177	Lock, A. M., & Co. Ltd.	—	255 Powell Duffryn Carbon Products Ltd.	—	Unilever Ltd.
—	Longman Green & Co. Ltd.	—	G/Card Power-Gas Corporation Ltd.	—	Union Carbide Ltd.
162	Longworth Scientific Instruments Co.	—	146 Price Stutfield & Co. Ltd.	—	170 United Filter & Engineering Co. Ltd., The
188	Lord, John L., & Son	—	Prodorite Ltd.	—	196 United Wire Works Ltd., The
—	Loughborough Glass Co. Ltd.	—	Price's (Bromborough) Ltd.	825	G/Card Universal-Matthey Products Ltd.
—	Low & Bonar Ltd.	—	Pyrene Co. Ltd.	—	—
—	Lurgi Verwaltung GmbH	Back Cover	Pyrene-Panorama Ltd.	—	Volcrepe Ltd.
—	Luwa (U.K.) Ltd.	798	—	—	—
162	McCarthy, T. W., & Sons	830	Q.V.F. Ltd.	783	188 W.E.X. Traders Ltd.
188	McMurray, F. J.	—	Quickfit & Quartz Ltd.	—	189 Walker, P. M., & Co. (Halifax) Ltd.
187	Maine, B. Newton, Ltd.	—	—	—	8 Waller, George, & Son Ltd.
134	Manesty Machines Ltd.	—	154 Reade, M. G.	—	Ward, Thomas W., Ltd.
129	Marchon Products Ltd.	823	241 Reads Ltd.	—	Warren-Morrison Ltd.
—	May & Baker Ltd.	—	Reavell & Co. Ltd.	—	148 Watson, Laidlow, & Co. Ltd.
—	Mechans Ltd.	—	Recontainers Limited	—	Watson-Marlow Air Pump Co.
Front Cover	Metal Containers Ltd.	—	Rheem Lysaght Ltd.	—	125 Wellington Tube Works Ltd.
G/Card	Metaloc (Britain) Ltd.	—	Rhodes, B. & Son Ltd.	—	242 Whitaker, B., & Sons Ltd.
146	Metcalf & Co.	—	Richardson Scale Co. Ltd.	—	Widnes Foundry & Engineering Co. Ltd.
—	Metering Pumps Ltd.	—	Richmond Welding Co. Ltd.	787	253 Wilcox, W. H., & Co. Ltd.
130	Metropolitan-Vickers Electrical Co. Ltd.	—	243 Rosin Engineering Co. Ltd.	—	137 Wilkinson, James, & Son Ltd.
—	Middleton & Co. Ltd.	—	Ross Ensign Ltd.	—	142 Williams & James (Engineers) Ltd.
178	Mirreles Watson Co. Ltd., The	—	260 Rotameter Manufacturing Co. Ltd.	—	Witco Chemical Co. Ltd.
—	Mirvale Chemical Co. Ltd., The	—	—	—	142 Wood, Harold, & Sons Ltd.
—	Mitchell, L. A., Ltd.	—	192 S.P.E. Company Ltd.	—	184 Worcester Royal Porcelain Co. Ltd., The
120	Mond Nickel Co. Ltd., The	—	Sandiacre Screw Co. Ltd., The	—	—
—	Monkton Motors Ltd.	802	Saunders Valve Co. Ltd.	—	Yorkshire Engineering & Welding Co.
—	Monsanto Chemicals Ltd.	—	Scientific Design Co. Inc.	—	(Bradford) Ltd.
—	Morgan Refractories Ltd.	—	Scott, Bader & Co. Ltd.	—	150 Yorkshire Tar Distillers Ltd.
178	Moritz Chemical Engineering Co. Ltd.	830	174 Scottish Tar Distillers Ltd.	—	Young, A. S., & Co.
—	—	—	Sharples Centrifuges Ltd.	—	—
190	Nailesea Engineering Co. Ltd.	—	3 Shepbridge Equipment Ltd.	—	150 Zeal, G. H., Ltd.
—	National Coal Board	—	—	—	—

Decolorising CARBON

ALL GRADE
FOR
ALL TRADES

HIGHEST EFFICIENCY
LOWEST PRICES

Granular Carbon for Solvent Recovery
Regeneration of Spent Carbon

Write for samples and quotations.

FARNELL CARBONS LIMITED
CONDUIT ROAD, PLUMSTEAD, LONDON, S.E.18

Telephone:

Woolwich 1158 (2 lines)

Telegrams:

Scofar, Wal, London

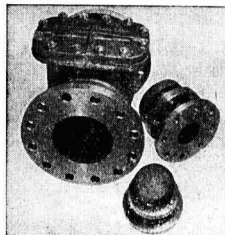

FLAME TRAPS
TO OUR OWN
DESIGN AND SIZE
IN ANY METAL

RICHMOND WELDING COMPANY

ESTABLISHED 1929

RICHMOND ROAD, BRADFORD 7

TELEPHONE 25405

FOR INDUSTRY

Propylex
TRADE MARK

POLYPROPYLENE SHEETING

Because **Propylex** is
 HEAT AND CHEMICAL RESISTANT
 STERILIZABLE
 LIGHT WEIGHT (specific gravity 0.91)
 RESISTANT TO CRACKING
 and has an
 EXCELLENT SURFACE FINISH

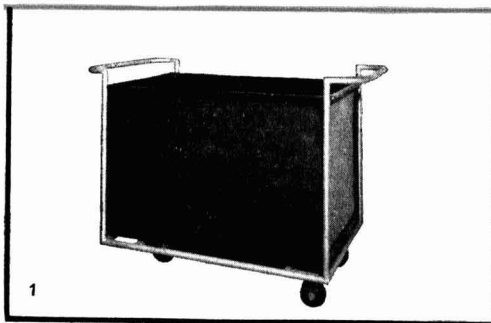

1

AVAILABLE IN SHEET UP TO 8' x 4'
 THICKNESS .010" to .180"

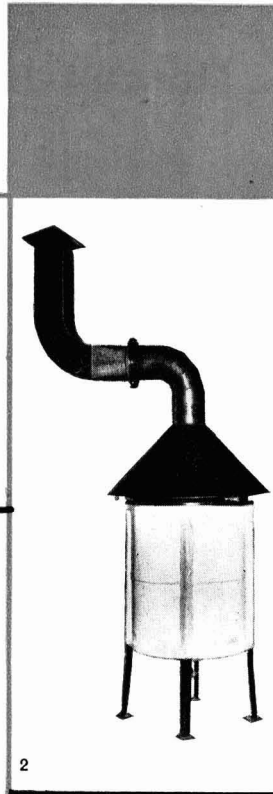

2

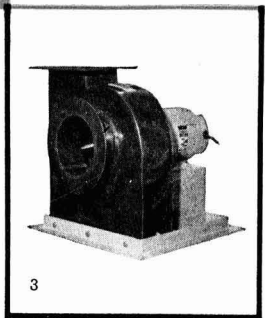

3

1. DYEHOUSE TRUCK
Manmil Plastics Limited,
Stalybridge, Cheshire.
2. PROCESS TANK
James Coates Bros. Limited,
Middleton, Lancs.
3. BOOSTER FAN
Resistant Equipment Limited,
76 Rivington Street,
London, E.C.2.

Samples and prices on application to:—

SPL 3

Plastics Division

British Celanese Limited

CELANESE HOUSE, HANOVER SQUARE, LONDON, W.1



VERSATILE FUNGICIDE AND BACTERICIDE FOR INDUSTRY—

Whatever your business, you'll find 'TOPANE' the best germicide you can buy. Outstanding in safety and non-toxicity, 'TOPANE' also fills the bill in efficiency and economy. Consider the low concentrations of 'TOPANE' needed to control the growth of these prevalent fungi and bacteria:

Industry	Species of fungi or bacteria prevalent	% for inhibition of growth	Industry	Species of fungi or bacteria prevalent	% for inhibition of growth
Disinfectants	<i>Aerobacter aerogenes</i>	0.032	Adhesives	<i>Bacillus subtilis</i>	0.016
	<i>Bacillus rubricus</i>	0.004		<i>Aspergillus flavus</i>	0.008
	<i>Escherichia coli</i>	0.032		<i>Paecilomyces varioti</i>	0.008
	<i>Pseudomonas caudata</i>	0.032		<i>Penicillium variabile</i>	0.004
	<i>Staphylococcus aureus</i>	0.032	Timber	<i>Ceratocystis pilifera</i>	0.008
	<i>Trichophyton interdigitale</i>	0.008		<i>Coniophora cerebella</i>	0.008
		<i>Merulius lacrymans</i>		0.001	
Textiles and Ropes	<i>Aspergillus niger</i>	0.004	<i>Polystictus versicolor</i>	0.008	
	<i>Chaetomium globosum</i>	0.008	Foods	<i>Alternaria citri</i>	0.008
	<i>Cladosporium herbarum</i>	0.008		<i>Diplodia natalensis</i>	0.010
	<i>Memnoniella echinata</i>	0.004		<i>Penicillium italicum</i>	0.016
	<i>Myrothecium verrucaria</i>	0.002		<i>Rhizopus nigricans</i>	0.016
	<i>Penicillium notatum</i>	0.008			

'TOPANE' (I.C.I.'s brand of ortho phenylphenol) is soluble in organic solvents, and 'TOPANE' WS (I.C.I.'s brand of sodium ortho phenylphenate) is its water-soluble grade. Both products are lethal to many bacteria, fungal spores, surface mildews, and rots, and can be employed to protect organic matter against most forms of microbiological degradation.

'TOPANE' COMBINES EFFICIENCY WITH OUTSTANDING SAFETY

1. DISINFECTANTS

'Topane' is a powerful weapon against infection. It broadens the killing range of disinfectant formulations against both Gram-positive and Gram-negative bacteria, and has low affinity for extraneous organic matter and low toxicity to higher life. 'Topane' is not classified as a poison and its high efficiency plus safety-in-handling recommend it in domestic, veterinary and industrial disinfectants.



2. TEXTILES and ROPES

Rotproofed with 'Topane', textiles and ropes stay strong, last longer. Effective and persistent, easy and economical to use, non-toxic and non-irritant, 'Topane' gives excellent protection against rot caused by bacterial and fungal attack to ropes and fishing-nets, canvases, carpets and felts, rubberised or p.v.c.-coated fabrics and textile finishes.



3. ADHESIVES

'Topane'-preserved adhesives are fully protected against bacteria and fungi. Incorporated early in the manufacture of the adhesive, 'Topane' ensures the protection of the finished product even after subsequent reconstitution and use. 'Topane' is ideal for the preservation of adhesives incorporating glue and gelatine; starch, dextrin and cellulose; casein; blood and albumin; and latex.

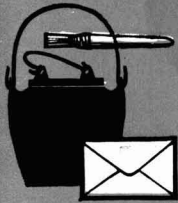

4. TIMBER

Deadly to wood-destroying fungi but non-toxic to humans, 'Topane'-based formulations are safe and economical for treating wet and dry rot in buildings and boats or for preventing sap-stain in freshly sawn timber. Tests carried out on highly resistant fungi show that 'Topane' gives outstanding protection to both soft and hard woods. It may also be used in conjunction with insecticides to give single-treatment timber protection.



5. FOOD STORES

Food stores disinfected with 'Topane' prevent waste and cut losses. Stored food is vulnerable to bacterial and fungal attack; 'Topane' kills food-spoiling bacteria and fungi. Cleaning and disinfecting with 'Topane' helps to keep stored food fresh by eliminating the sources of infection in warehouses, bakeries, breweries, ships' holds and slaughterhouses, and maintains the hygienic conditions essential wherever food products are prepared, stored or transported.

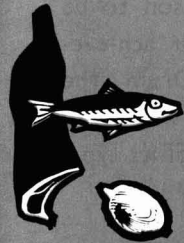

6. YOUR PROBLEM?

We have mentioned some of the major applications of 'Topane' preservatives. There are many more potential uses of 'Topane'. Perhaps, after reading this advertisement, you may think 'Topane' can help you solve a problem in your industry. Let us know about it—we shall be glad to assist you while extending our own knowledge of the applications of 'Topane'.



NAME COMPANY

ADDRESS TEL. No.

Please send further information on 'TOPANE' for Application No.

Please arrange for representative to call to discuss 'TOPANE' for Application No.

(If your interest is aroused by Application No. 6, please enclose with this coupon a brief statement of the problem.)



SYMBOLS OF ACHIEVEMENT

There have been 3 F.A. Cups. The original (first presented in 1872) was stolen in Birmingham in 1895 and never recovered. A replica was made but in 1911 the present cup was designed and registered to prevent the flagrant copying of former years.

The winners of the F.A. Cup have every reason to be proud and happy. We too are proud of our achievement in pioneering the world famous K.C.C. Drum; the forerunner of all interrupted Chimb Drums. Hundreds of satisfied users maintain that it is still the best of its type.

SPECIFY

E. A. BROUGH & CO. LTD.
UPPER PARLIAMENT STREET,
LIVERPOOL 8 and of Speke.

Telephone: ROYal 3031-3 Grams: SUPERDRUM, LIVERPOOL 8

BROUGH'S

DRUMS



LITHIUM PRODUCTS

BIKITA ORES

Amblygonite	9.0% Li ₂ O
Lepidolite	4.0% Li ₂ O
Petalite	4.5% Li ₂ O
Spodumene	4.5% Li ₂ O
Eucryptite	5.0% Li ₂ O

CHEMICALS

Lithium Carbonate
Lithium Chloride Anhyd.
Lithium Hydroxide

BORON PRODUCTS

"Three Elephant" Brand

PYROBOR* (68.5% B ₂ O ₃)	Tech. 99% min Na ₂ B ₄ O ₇
V-BOR* (47.7% B ₂ O ₃)	Tech. 99.8% min Na ₂ B ₄ O ₇ .5H ₂ O
BORAX (36.5% B ₂ O ₃)	Tech. 99.5% min Na ₂ B ₄ O ₇ .10H ₂ O
BORIC ACID (56% B ₂ O ₃)	Tech. 99.8% min H ₃ BO ₃
BORIC OXIDE (98.5% min B ₂ O ₃)	High Purity.

CAESIUM PRODUCTS

BIKITA Pollucite
26% Cs₂O

MARKET DEVELOPMENT PRODUCTS

BORON - Metallic Lithium Metal
Boron Trichloride N-Butyl-Lithium
Lithium Fluoride
Thorium, Yttrium & Rare Earth Metals
Rubidium & Caesium Salts

CERIUM, THORIUM, YTTRIUM AND RARE EARTH PRODUCTS

Cerium Optical Polishes
Thorium Oxides - High Purity
Rare Earth Fluoride (Cerium Fluoride)
Lanthanum Oxides and Oxalates
Praseodymium Oxides and Oxalates
Neodymium Oxides and Salts
Yttrium Oxides and Salts

Also High Purity Oxides and Salts

*Trade Marks of American Potash & Chemical Corporation.

For detailed information write to:

BORAX & CHEMICALS LTD.

(Subsidiary of American Potash & Chemical Corp.)

35 PICCADILLY, LONDON W.1

Telephone: REGENT 2751

Telex: LONDON 23782

Cables: BORAXCHEM LONDON

Air separation plant for the Chemical Industry



Erection of a Tonnage Oxygen installation for use in the gasification of solid fuel. The plant consists of two units each capable of producing 100 tons per day of oxygen under pressure and was built by The British Oxygen Company Limited. The air separation units were pre-erected at their Edmonton Works and supplied in packaged form.

Tonnage Oxygen and Nitrogen Plant

PLANTS FOR AIR AND GAS SEPARATION

BOC has unrivalled experience in building a wide range of plants specifically designed to meet the diverse requirements of the Chemical, Steel and Gas industries. Continuous bulk demands for atmospheric gases are best met by plant installed close to the point of usage. The consumer can either own and operate such plant or take supplies by pipeline from a BOC installation.

PURIFICATION PLANTS

BOC are specialists in the design and construction of plants for the purification of nitrogen, argon, helium and the rare gases. Very high purity products can be obtained.

ANCILLARY EQUIPMENT

All types of ancillary equipment, associated with air separation plants, are designed and manufactured by BOC. These include a wide range of liquid storage tanks, pumps, evaporators and compressors.

CRYOGENIC ENGINEERING

The specialist skill and knowledge accumulated over many years enables BOC to provide a comprehensive service to all users of atmospheric gases and in cryogenic engineering applications. The benefits of BOC's experience and tradition are free to customers, and experts are always available for discussion and advice—a complete service from pre-sales consultation through all stages of design and construction to after-sales advice and co-operation.

BOC MAKE

Complete Air Separation Installations for Oxygen, Nitrogen and Rare Gases
 Transportable Oxygen Plants · Gas Purification Systems
 Liquid Oxygen Pumps and Vaporisers · Gas Compressors
 Gas and Liquefied Gas Storage Systems · Gas Separation Plants

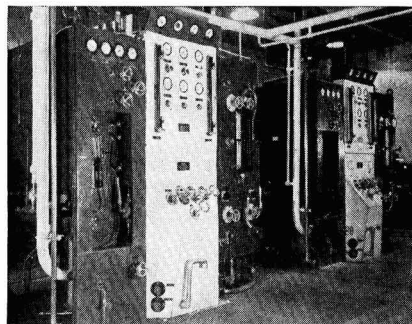

Liquid Oxygen Plants at the Argon Purification Plant, UKAEA, Dounreay

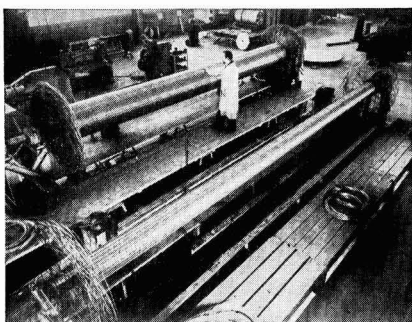

Cross Flow Heat Exchangers

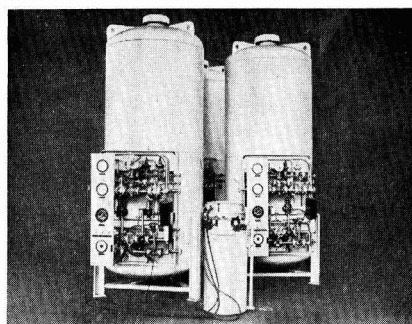

Vacuum Insulated Evaporators

For air separation plant—first consult

The British Oxygen Company Ltd

HEAVY INDUSTRIAL DEPARTMENT Spencer House, St. James's Place, London, SW1. HYD 3051



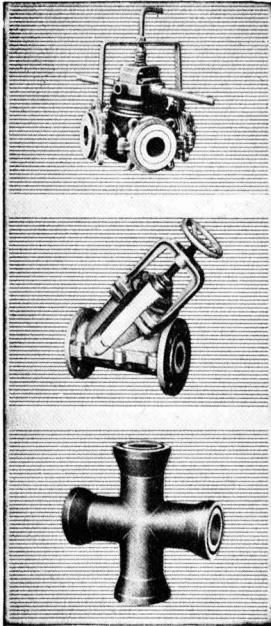

**Pumps
Cocks
Valves
Piping**
made of
acid-proof
stoneware

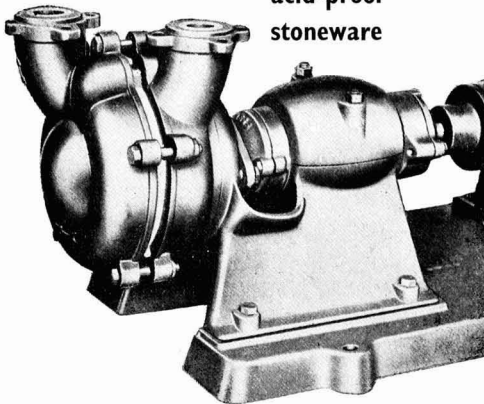

**DEUTSCHE STEINZEUGWARENFABRIK
MANNHEIM - FRIEDRICHSFELD**

Sole representative:—

ANDERMAN & COMPANY LIMITED
BATTLEBRIDGE HOUSE, 87-95 TOOLEY STREET, LONDON, S.E.1
Tel: HOP 0035/6 & HOP 1169 Telegraphic Address: Deran, Phone, London

CROMIL & PIERCY LTD.



GRAPHITE
IN ALL FORMS

MILBURN HOUSE
"E" FLOOR
NEWCASTLE-ON-TYNE
Tel: 2-7761



At your service . . . a fleet of
TANKERS for the **TRANSPORT**
of

**BULK
LIQUIDS
POWDERS**
and
GASES

**CROW
CARRYING
CO. LTD.**

HARTS LANE, NORTH STREET
BARKING, ESSEX

Telephone: Rippleway 0366

and

231 GREENGATE, MIDDLETON
JUNCTION, MIDDLETON
MANCHESTER

Telephone: Fallsworth 3353

MOTOR CONTROL CENTRES

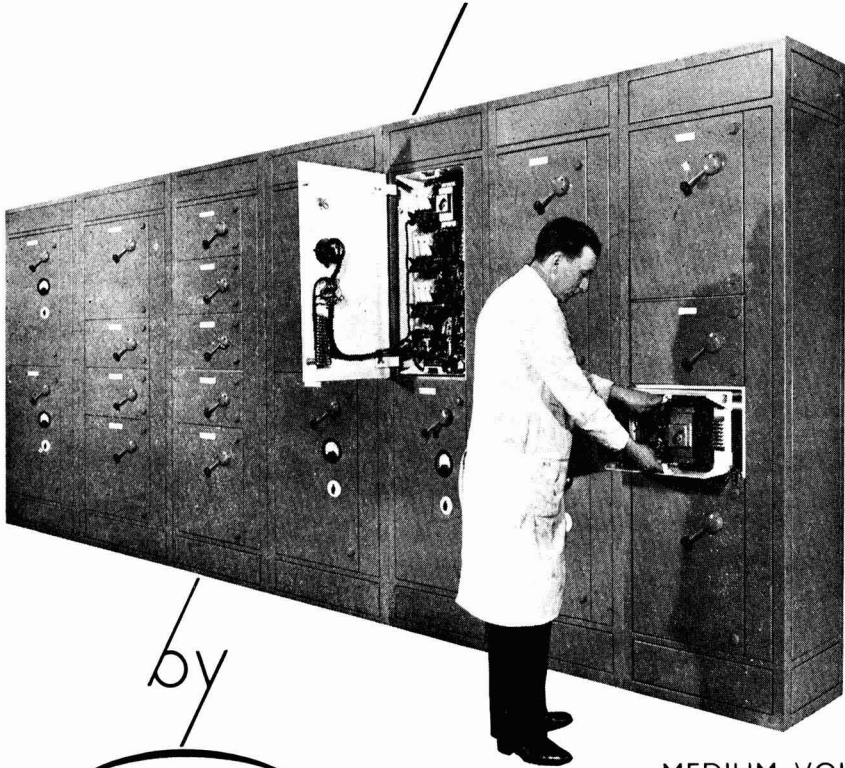

by

AEI

MEDIUM VOLTAGE.
UP TO 100 h.p.

**SOLVE YOUR GROUPED CONTROL PROBLEMS
CUT INSTALLATION COSTS
SAVE SPACE
SIMPLIFY MAINTENANCE**

Type CCW control centres consist of standardised, free standing cubicles containing withdrawable starter units plugged on to vertical busbars. Units are interchangeable, back-to-back formation when required. Boards are extendible, facilitating forward planning.

Write for further details

ASSOCIATED ELECTRICAL INDUSTRIES LIMITED

MOTOR & CONTROL GEAR DIVISION

RUGBY & MANCHESTER, ENGLAND

A 5543

INSTANTANEOUS JOINTS

*Leakproof.
safe...
reliable!*



For permanent or semi-permanent pipelines 'UNICONE' bolted pipe joints are employed.

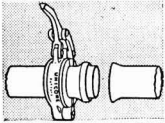

Rubber gasket in position and joint ready to pull over.

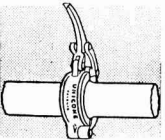

Pipe ends joined ready for locking.

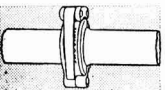

The completed joint.

For temporary pipe lines 'Unicone' instantaneous joints are recommended. Comprising two parts only, they fasten with a "snap" ensuring a perfect seal in a matter of seconds.

For permanent or semi-permanent pipe lines, 'Unicone' bolted type joints are usually employed and can be assembled far more quickly than any other flexible joint giving positive anchorage.

A perfect joint in a matter of seconds...

The 'Unicone' system of pipe-jointing, with its time and labour saving features, produces a pipe line which is flexible while remaining absolutely leak-proof.



THE UNICONE CO., LIMITED
RUTHERGLEN, GLASGOW, SCOTLAND

▽ G



A NEW ECONOMY OVEN

for Laboratories, Teaching Centres and Workshops

Low cost combined with reliable performance makes this new Pickstone Economy Oven an attractive buy for all who need a Laboratory Oven. Made throughout of mild steel. Heating chamber finished with a high temperature-resisting aluminium coating, and fitted with two 1" weldmesh trays. Fibreglass insulation separates exterior from heating chamber. Insulated cavity-type door has simple lock. Fittings include thermometer aperture; on-off switch; quick-read calibrated thermostat control knob.

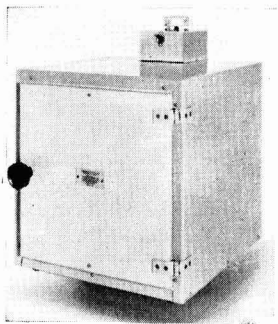

COMPACT · ROBUST · SIMPLE AND EFFICIENT

Overall dimensions: 12" × 15½" × 15½" (high)
Heating Chamber: 10" × 10" × 10"

Operating Temps.: 5° above ambient to 200°C
Heating-up time: To 200°C—One Hour
Temperature Fluctuation is of the order of ± 2° at 200°C.

Order with confidence or write for Technical Leaflet to:

R. E. PICKSTONE LTD.
Dept. C.A.

36, Avon Trading Estate, Mornington Ave., London, W.14
FULham 4558

W.M. FLOWLINE

VALVES

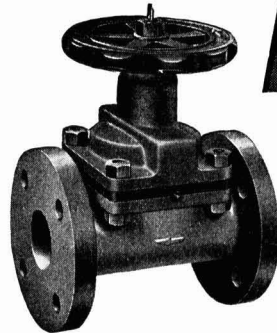

Warren-Morrison experience in design and production of specialist valves has led to the introduction of this range of diaphragm valves. Designed

for the widest possible range of duties, they incorporate many features appreciated by the operator. From a safety point of view this valve will shut off, even if the diaphragm does fail. For convenience, a visible position indicator is fitted. From the long-life angle the valve is heavily made, using only the best of materials and workmanship. For the really difficult jobs 'all P.T.F.E.' diaphragms are available; another example of W.M. leadership in valve design. Electric or pneumatic operation is available, of course.

WARREN-MORRISON LTD

41 ST JAMES'S PLACE, LONDON S.W.1.

MAYFAIR. 9895

FULLER AIRMERGE SYSTEM

AERATION BLENDING AT FULL MATURITY

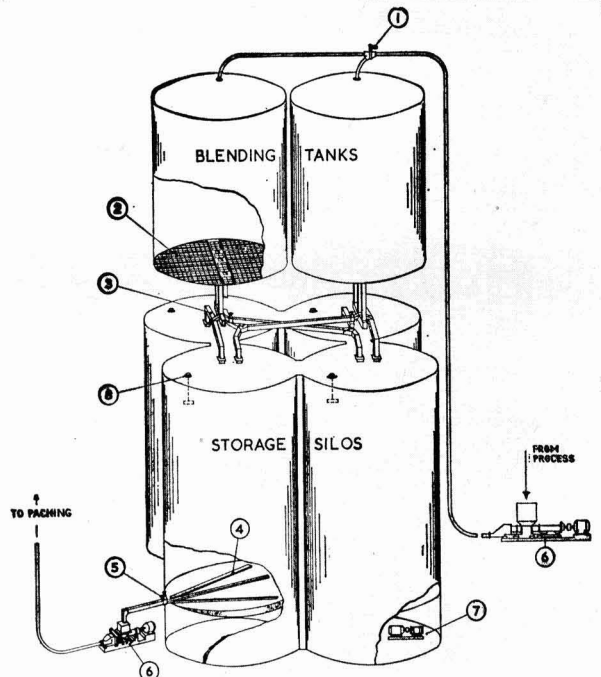

- | | |
|---|-----------------------------|
| 1. FULLER KINYON MOTOR OPERATED TWO WAY VALVE | 5. FLOW CONTROL GATE |
| 2. AERATION BED (QUADRANT SYSTEM) | 6. FULLER KINYON PUMP |
| 3. 'F-H AIRSLIDE' TRANSFER CONVEYOR | 7. COMPRESSOR HOUSE |
| 4. 'F-H AIRSLIDE' WITHDRAWAL CONVEYOR | 8. MINERAL LEVEL INDICATORS |

The Airmerge System has demonstrated these advantages for all who have to handle mixed powdered materials. (1) Thorough homogenization even when the blended materials differ in bulk density and fineness. (2) High capacity in tonnage through-put in a silo of moderate size. (3) High capacity in tons per hour means a saving in man-hours per ton. (4) Unequalled economy in k.w.h. per ton of blended product. (5) No other known process does an equal job in blending large volumes of dry material. (6) This system is ideally suited for use in either batch or continuous operations.

HOMOGENIZATION IS THE END RESULT

To ensure the perfect performance of an Airmerge installation, Constantin (Engineers) Ltd. are prepared with a fully equipped laboratory to test all materials submitted, to determine their fluidizing characteristics, and to provide the basic data necessary for designing an effective assembly of blending equipment.

FULLER PLANT

for the Chemical Industry also includes Fuller-Kinyon Pumps, *'F-H. Airslide'' Fluidizing Conveyors, Grate Coolers, Rotary Gate Valves, Material Level Indicators, Remote Control Panels, etc., details of which are available on request.

Send your enquiries to:—

CONSTANTIN (ENGINEERS) LTD.

123 VICTORIA ST., LONDON, S.W.1. Tel: TATE GALLERY 0637

(Sole licensees for the manufacture and sale of Fuller equipment in Great Britain)

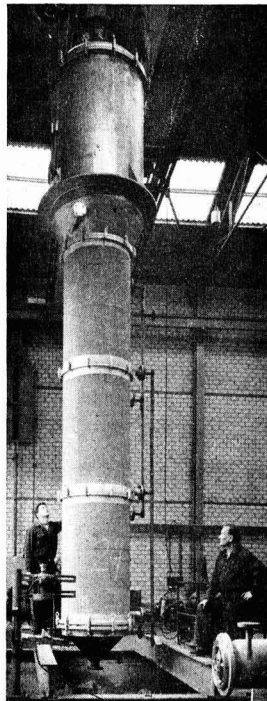

LUWA THIN LAYER EVAPORATOR

For

- EVAPORATION
 - DISTILLATION
- CONCENTRATION
 - DEODORISATION

of all heat-sensitive liquids in any range of temperature, vacuum or capacity.

The modern Luwa system ensures for you the highest product quality, improved yields and the advantages of rapid continuous processing.

Why not take advantage of our great experience in the treatment of heat-sensitive liquids. The superiority of the Luwa Evaporator has been proved in the manufacture of many products including:—

- Dyestuffs
 - Plasticisers
 - Heavy and fine organic chemicals
 - Natural and synthetic latices
 - Fruit juice concentrates
 - Vitamins and antibiotics
- Urea
 - Gelatine

Also available: High Vacuum Fractionator · Air Conditioning

Write for details:—

LUWA (UK) LTD., Reliance House, 340 Clapham Rd.,
London, S.W.9

Telephone: Macaulay 7776

Offices: Zürich · Frankfurt · Paris · Barcelona · São Paulo
Havana · Mexico City · Charlotte (USA)

MIXING VESSELS

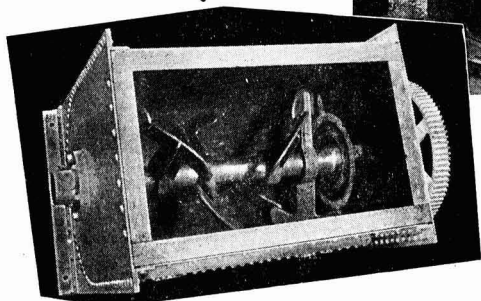
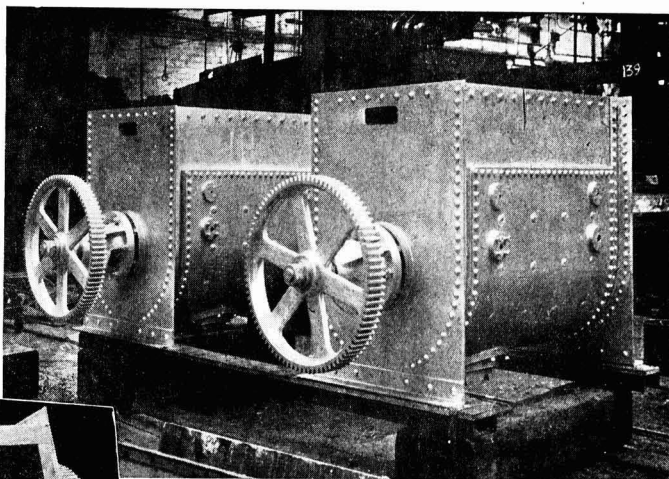

These hot water jacketed Mixing Vessels (capacity $\frac{1}{2}$ Ton each) are for use in chocolate manufacture. The lower photograph shows the stirring gear.

• • •

We manufacture Mixers, Blenders and Process Vessels for a wide range of Industries and applications.

POTT, CASSELS & WILLIAMSON LTD · MOTHERWELL · SCOTLAND
A Member of THE MIRRLEES WATSON GROUP

HINDLE AGAIN

The Leakproof Valve People
make history with the
first BRITISH Fluon Seated
Leakproof BALL VALVE
One Piece Body • • Remarkably Compact

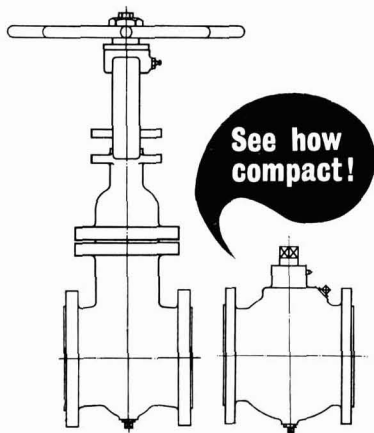

Quarter-turn operation. Positive Seal upstream and downstream. Seats can be easily replaced. Full diameter bore. No gaskets. No bolting. Ask for Hindle Catalogue Number A3

B15
VALVE
with
one-
piece
body



Available in Carbon Steel for Oil Service
and Stainless Steel for Chemical Service
WORLD PATENTS PENDING

JOSHUA HINDLE & SONS LTD., HINDLE HOUSE, LEEDS 1
Telephone: Leeds 30567 (4 lines) Telegrams: Joshindle, Leeds
LONDON OFFICE: 157 Prince's Gardens, Acton W.3 Telephone: ACOrn 2471



Filter aids

CLARCEL

NEW CLARCEL FLO

The most widely used diatomaceous filter aids in Europe.
 Purity — uniformity and high performance with maximum economy.

Expanded Perlite base filter aids
 MANUFACTURED IN THE UNITED KINGDOM
 offering exceptional economy and high efficiency.

Samples and technical information on request.



THE BRITISH CECA COMPANY LTD.

INDUSTRIAL PRODUCTS
 DIVISION

175, PICCADILLY, LONDON, W.1.

Telephone : HYDe Park 5131
 Telegrams : ACTICARBON, LONDON, TELEX.
 Cables : ACTICARBON, LONDON



DYESTUFF INTERMEDIATES

including :

DIHYDROXY NAPHTHALENES

also—

DICYCLOHEXYLAMINE

MONOETHANOLAMINE

DIETHANOLAMINE

TRIETHANOLAMINE

Write Dept. A/1 for full details.



J. M. STEEL & CO. LTD.

36-38 KINGSWAY, LONDON, W.C.2 Tel. HOLborn 2532/5

Branch Offices:

73/79 KING ST., MANCHESTER 2.

Tel. Deansgate 6077/9

45 NEWHALL ST., BIRMINGHAM 3.

Tel. Central 6342/3

144 ST. VINCENT ST., GLASGOW C.2.

Tel. Central 3262

CARLESS

*Hydrocarbon
Solvents and
Diluents*

SPECIAL NAPHTHAS

- Specific gravity 0.860—0.865
- Distillation range 145°C—180°C
- Flash point minimum 87°F
- Specifications varied to meet requirements of individual customers

Let us send you a sample and a quotation

CARLESS, CAPEL & LEONARD, LTD.
HACKNEY WICK, LONDON, E.9 *Amherst 5500*



LIQUIDS IN BULK

We are specialists in the bulk transport of the following

ACIDS • CHEMICALS • ALKALIS
SOLVENTS • CAUSTICS • EMULSIONS
PETROLEUM • PRODUCTS

Continental Enquiries Welcomed

MONKTON MOTORS LTD.
WALLINGFORD ROAD, UXBRIDGE, MIDD.

Telephone : UXBRIDGE 35574/5

VOL. 85

No. 2184

MAY 20 1961

Telephone: FLEet Street 3212 (26 lines)

Telegrams: Benformula - Cent - London

Editor

M. C. HYDE

Manager

R. C. BENNETT

Director N. B. LIVINGSTONE WALLACE

Midland OfficeDaimler House, Paradise Street,
Birmingham. [Midland 0784-5]**Leeds Office**Permanent House, The Headrow,
Leeds 1. [Leeds 22601]**Scottish Office**116 Hope Street, Glasgow C2.
Central 3954-5]**IN THIS ISSUE**

Italian Fertiliser Prices	804
Project News: Cyanuric Acid for Whiffens: Bexford Polymer Plant	805
Distillates	806
Montecatini Managing Director Interviewed	807
British Fair at Moscow	809
Beck Koller and Phthalic	810
Canadian Tariff Hearing	811
Low-volume Spray Formulation	812
ANIC and Sicedison Expansion Plans	813
1 m. Tons of Fertiliser for India	815
Overseas News	817
Bookshelf	819
People in the News	821
Commercial News	822
Trade Notes	824
Diary Dates	824
New Patents	826
Market Reports	826

Annual subscription is: home, 57s 6d, overseas, 65s, single copies 1s 9d (by post 2s)

Chemical Age

Incorporating

PETROCHEMICALS and POLYMERS

BOUVERIE HOUSE · 154 FLEET STREET · LONDON · EC4

ANGLO-ITALIAN RELATIONS

THE Queen and the Duke of Edinburgh visited Italy at a time of great industrial activity, writes the Benn Brothers correspondent with the Royal Tour, which ended in Turin at the Italia '61 Exhibition last week. There the Royal party were able to see something of the dynamic expansion which has taken place in recent years to give Italy Europe's largest growth in industrial production generally as well as in chemicals.

Based on a 1953 index of 100, in 1960 industrial production stood at 182 (158 in 1959), compared with a Common Market index of 171 (153 in 1959), a West German figure of 180 (162 in 1959) and the U.K. with a 1960 index of 130 (122 in 1959). For the chemical industry, Italy's index stood at 244 (209 in 1959), compared with a Common Market figure of 226 (193 in 1959), a West German figure of 226 (196 in 1959) and Great Britain with 148 last year (145 in 1959). Italy leads Europe too in the production of natural gas, with an output of some 6,310 million cu. m. in 1960.

When the Queen and the Duke visited the International Labour Pavilion in Turin they were able to see—on the Italian stand which depicted the development of all forms of energy—how the discovery of large-scale natural gas deposits have transformed the Italian economy. Already the world's first natural gas pipeline network traverses the Po Valley taking the product to chemical plants throughout the north. Now new and large deposits have been discovered in the less-developed areas of the south, where most of the petrochemical developments of the future will take place. There are plans too to pipe natural gas to Sicily under the Mediterranean from the French Sahara and to connect Sicily with the mainland.

This cheap and abundant source of chemical feedstock, coupled with a strong and stable economy, are undoubtedly the reason why so many U.S. chemical companies are currently investing in Italy.

The strong cultural and commercial links between the U.K. and Italy were well catered for at the Turin exhibition, which is being held to commemorate Italy's centenary of unity. At the International Labour Pavilion, the British exhibit demonstrated the international nature of science and technology. This was a fitting theme for, to quote only one aspect of Anglo-Italian relations, Professor Ernst Chain, renowned for his pioneering work on penicillin and his later discoveries on the synthesis of penicillin while working in Milan, has for long collaborated on this subject with the British Beecham Group.

One of the themes of the British exhibit was major 'breakthroughs' in research, including antibiotics, with one of the highlights being the success of Beecham Research Laboratories in the isolation of the chemical nucleus of penicillin. As has been stated before, the really important aspect of this co-operative research by Chain and Beecham workers lies in the fact that it opens up the possibility of killing bacteria at present unaffected by the ordinary penicillins.

Other 'breakthroughs' by the British pharmaceutical industry, seen by the Royal party in Turin, were Glaxo's girseofulvin, a unique anti-infection agent for oral administration; Glaxo's vitamin B₁₂, or cyanocobalamin, simultaneously developed with U.S. workers, and their quick acting thyroid

(Continued on page 804)

Montecatini President Says Pressure Groups are Depressing Italian Fertiliser Prices

AT the recent annual meeting of Montecatini, Count Carlo Faina, president, stated that the group was anxious to make an ever-increasing contribution to the development of southern Italy and to reach production levels in keeping with the demands of the Common Market. These are the main reasons why Montecatini stepped up investments in 1960, embarking on construction of their £40 million petrochemical plants at Brindisi, the exploitation of potash in Sicily, erection of plant at Bussi which will be fed by the first south Italian pipeline that will bring methane recently found by the company at Cellino (Abruzzi), plus industrialisation of the Port of Augusta and construction of a plant at Priolo.

Another reason for expansion was the fact that the present day was an era of large-scale enterprises; a company like Montecatini had not only to keep abreast of technical discoveries but also to ensure that capacities were suitably large enough. Sales of Montecatini companies operating in Italy totalled about Lire 350,000 million. Despite continual expansion, all plants were operated to capacity.

Giving production figures, the president said that last year 1,379,783 tonnes of pyrites were produced; output of the new San Cataldo potash mine totalled 3,000 tonnes/day; sulphuric acid make totalled 1,237,449 tonnes, while a new phosphorus plant went on stream at Crotona. During 1961 a large-scale titanium oxide plant is due on stream at Spinetta Marengo.

Montecatini were still pre-eminent in fertilisers, but Count Faina drew attention to the fact that prices of Italian nitrogen

fertilisers were the lowest in the world. He added that he could not understand why certain authorities and 'pressure groups' in Italy insisted on demanding from Italian industry prices that were lower than in other countries.

Further progress was made in the polymerisation of olefins. A second plant for Moplen polypropylene had gone on stream at Ferrara, to be followed shortly by a third. The first Moplen Brindisi plant would be operational early in 1962. The latest overseas polypropylene licence had been granted to Svensak Esso for distribution in Scandinavian countries; other negotiations were in hand.

The next new Montecatini material would be polybutylene, pilot plant production of which was in hand at Ferrara, as was pilot-scale production of the ethylene-propylene copolymer, Dutral. Next year, Dutral will be produced on an industrial scale at Brindisi. More than 24,000 tonnes of Fertene polythene were produced last year; this material is also scheduled for production at Brindisi. Excellent progress was made in the expansion of other plastics materials—Vipla and Crlat acrylic esters, Vedril methyl methacrylate and polymethylmethacrylate, Montivel polyester film and Mopletan polypropylene film.

The new polypropylene fibre Meraklon was in expanding production at Terni and output would be increased further when new Brindisi plants were in production.

In 1960 production of lead totalled 15,225 tonnes and that of zinc, 19,503 tonnes, the highest output attained at Porto Marghera in its 25 years of existence.

Planning in Heavy Organic Chemicals Industry

'Planning in the heavy organic chemicals industry' will be the title of the chairman's address to be given immediately after the annual meeting of the S.C.I. Heavy Organic Chemicals Group on Friday, 26 May. Dr. M. A. Matthews (Shell International Chemical Co. Ltd.), retiring chairman, will give the address at 6.30 p.m.; guests will be welcome. Annual meeting at 6 p.m. is restricted to group members. Venue is the S.C.I. headquarters at 14 Belgrave Square, London S.W.11.

S.A.C.'s Elwell Award for 1961

Intending candidates are reminded that entry forms for the Elwell Award, 1961, should be returned to Mr. G. W. Cherry, hon. secretary, Midlands Section, Society for Analytical Chemistry, 48 George Frederick Road, Sutton Coldfield, Warwick, by 7 June 1961, and papers should reach him by 30 June 1961.

Anglo-Italian Relations

(Continued from page 803)

hormone, tri-codothyronine; I.C.I.'s Etisul, anti-leprosy drug; the same company's Fluothane, halothane, anaesthetic, as well as their drugs for use against malaria, elipsy, and hyper-tension.

The Royal Tour not only came at a time of great industrial expansion in both the Italian and British chemical industries, but also at a time when trade in chemicals between the two countries has been increasing substantially. British exports of chemicals to Italy in 1960 totalled £10.3 million, an increase of 10.7% on 1959, while our imports from that country totalled £6.4 million, or 60% up on 1959. There are indications that this two-way flow will continue to increase, together with an ever increasing exchange of both process and scientific know-how.

Changes in Export Embargo List

MOLYBDENUM disulphide of a purity of 86% or more and high octane blending agents for aircraft fuels are two items that have been deleted from the list of goods subject to strategic embargo for export from the U.K. to the Soviet Bloc and China. Alterations have been made in the embargo as it affects boron, while a new item added to the list covers all polyphenyl ethers containing more than three phenyl groups.

Under the heading of 'Chemical and petroleum equipment', equipment for the conversion of dinitrogen tetroxide to nitric acid has been deleted, while the text of another item under this category is now amended to: "Counter current solvent extractors, such as pulsed columns and mixer settlers made of stainless steel, specially designed for extracting radioactive substances."

Further amendments to the list, published in the Board of Trade *Journal* for 5 May, affect certain types of scientific instruments and apparatus, control equipment, etc. Enquiries about the embargo should be addressed to the Commercial Relations and Exports Department, Board of Trade, Horse Guards Avenue, London S.W.1.

Montecatini Plan Brindisi Aromatics Plant

Plans of Montecatini for their new Brindisi chemical complex, first units of which are due on stream towards the end of next year, include a petroleum-based aromatics unit for products such as xylenes, toluene and benzene. There will also be a plant capable of producing up to 25,000 tonnes/year of petroleum naphthalene.

This news was disclosed in an exclusive interview that 'Chemical Age' had with Ing. Piero Giustiniani, Montecatini's managing director, last week at the company's head office in Milan. Ing. Giustiniani's belief that the Common Market should be expanded to include the U.K. and other E.F.T.A. countries, together with his comments on the Italian chemical industry, are reported on page 807.

Chemicals Lead in World's Post-war Expansion

THE United Nations Statistical Year Book for 1960 shows that among the world's manufacturing industries, chemicals, including coal and petroleum products, showed the greatest expansion in the period 1948 to 1959 with an increase of 148%. Chemicals were followed by metal products with a 97% rise and by non-metallic mineral products, up 68%. These figures do not include Communist states.

The index for east and south-east Asia, excluding mainland China, for chemicals, including coal and petroleum products, showed a rise of 268%, below metal products (667%), paper industry (159%), basic metals (367%) and non-metallic mineral products (327%).

Project News

B.P. Group Plans French Butadiene Propylene and Polybutenes Units

AMONG the new petrochemical plants mentioned in the annual report of **British Petroleum** are a number in France and Germany which had not been previously announced.

In France, new plants are under construction for the production of butadiene, high-purity propylene and polybutenes by Naphthachimie, in which B.P. have a substantial holding through their French associate.

In Germany, Erdölchemie, in whom B.P. have a 50% interest through their German associate, have commissioned a new cracking plant at their Dormagen factory and units for the manufacture of ethanol, ethylene oxide and ethylene glycols. A butadiene plant started operation at the end of the year and further plants are under construction. No details of the plants in either France or Germany are available.

The Group's share of capital expenditure in petrochemical plants in the U.K., Germany and France and in the manufacture of lead antiknock additives was at the end of 1960 about £47 million. Most of these operations are based on the steam cracking of feedstocks supplied by the B.P. refineries, but during 1960 three plants were installed to use the B.P. hydrotreating process. The total capital expenditure of the Group during 1960 on petrochemicals was £6.25 million compared with £4.25 million in 1959.

Reichhold Defer Plans for Brockhampton Vinyl Plant

● PLANS for building the new **Reichhold Chemicals Ltd.** vinyl factory at Brockhampton have been deferred for the time being, the late Mr. W. H. Breuer, chairman of the company, reported in his annual statement (see also page 810). The new resin plant at Speke should be in production by the end of this month. The new plant of the Reichhold subsidiary Vinatex Ltd. at Havant, Hants, is expected to be in full production within a few months and should increase the present rate of production by one-third. Months of delay in plant delivery and subsequent teething troubles substantially reduced the profit earning capacity of Vinatex during the year.

Blaw Knox to Build Polymer Plant for Bexford

● PLANT for the production of polymer is to be designed, engineered and constructed by **Blaw Knox Engineering Co. Ltd.** for **Bexford Ltd.**—who are associated with BX Plastics Ltd. and also with Ilford Ltd.—at Brantham, Manning-

tree, Essex. The plant is scheduled for completion later this year.

At Manningtree, Bexford have the largest factory within the Commonwealth producing film base for photographic purposes and industrial film for a variety of commercial uses. It was reported in C.A., 22 April, p. 651, that Constructors John Brown Ltd. had been awarded a contract covering extensions to the works.

Whiffen Plan Unit for Cyanuric Acid

● PLANT to make 350 tons/year each of cyanuric and trichlorocyanuric acids are under construction at the Loughborough Works of **Whiffen and Sons Ltd.**, one of the Fisons Group. It is claimed that output will be sufficient to enable the company to meet total U.K. needs and to provide a surplus for export. Provision has been made for expansion of output as necessary. The initial plant will cost an estimated £100,000.

Cyanuric acid is a chemical intermediate; trichlorocyanuric is used mainly as a bleaching agent in domestic cleansing preparations and applications are expected in dairy sanitising compounds.

Currently, the only other U.K. producers are the Cocker Chemical Co. Ltd.

B.H.C. Ethylene Dichloride Unit on Stream Soon

● LARGE-SCALE ethylene dichloride plant of **British Hydrocarbon Chemicals Ltd.** will come on stream at Grangemouth in July-August this year. Main contractors are the **Lummus Co. Ltd.**, who are also to build an identical unit for B.H.C. at their new Baglan Bay site.

Bulk of the Grangemouth production of ethylene dichloride will be shipped to

the Distillers Plastics Group works at Barry, Glam., where it will be used for the production of vinyl chloride and hence p.v.c. Ethylene dichloride (1:2 dichloroethane) has many solvent applications in paint stripper formulations, rubber cements, vegetable oil extraction and metal degreasing. As a chemical intermediate, it can be used for the preparation of ethylene diamine and succinonitrile. In admixture with carbon it is used for grain fumigation.

Commercial enquiries should be addressed to the selling agents, the D.C.L. Chemical Division, Devonshire House, Piccadilly, London W.1, or to their regional sales offices.

F.W. Link with CJB Australia on Kwinana Lube Project

● CONTRACT for the design, engineering, supply and construction of the process units required for the £5.6 m. lubricating oil project at the **British Petroleum Co.'s** Kwinana refinery, 25 miles south of Perth, has been awarded to Foster Wheeler Ltd., London. For this contract, Foster Wheeler have formed an association with Constructors John Brown (Australia) Pty. Ltd., which enables them to utilise an established organisation in Australia for the construction work.

The process units to be supplied for the project are for vacuum distillation, furfural extraction, M.E.K.-toluene dewaxing, and Ferrofining (hydrofinishing). The new plant is expected to go on stream at the end of 1962 with an annual capacity of 100,000 tons of high-grade lubricants.

MacLellan 'Inflatables' for A.E.A. Pipe Sealing

SPECIAL 'inflatables' for use by the U.K. Atomic Energy Authority in sealing gas pipelines while maintenance work is in progress have been developed by George MacLellan and Co. Ltd., rubber manufacturers, Shuna Street, Glasgow N.W.

The balloons, nine of which have been supplied to the A.E.A., are 54 in. in diameter and made of strong rubberised material. When inflated they effectively seal off any section of a pipe requiring attention. As heat is present, the balloons have been fitted with special release valves to allow for air expansion.

Port Talbot Benzole Hydrorefining Plant

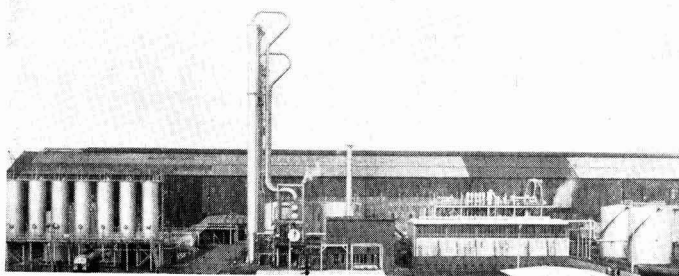

A view of the new benzole hydrorefining plant of the Port Talbot Chemical Co. Ltd., where an 'open day' was held recently

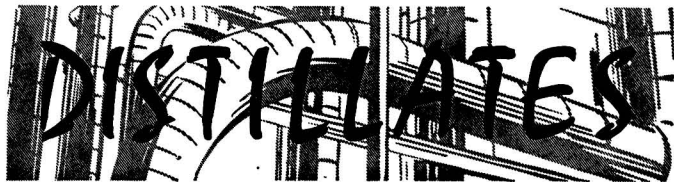

★ IN his struggle with the world's major oil companies, Mr. Enrico Mattei, president of the Italian State-controlled E.N.I. group now commands around 12.5 million tonnes of crude a year. The two Stannic refineries—jointly owned by ANIC and Standard Oil of New Jersey, in 1960 processed a throughput of 4.5 million tonnes of crude, an increase of 29%. Approval has now been given to raise throughput at Bari to 3.5 million tonnes and Leghorn to 3 million tonnes, plus a legal reserve of 30%.

The Morocco refinery will come on stream towards the end of this year with a throughput of 1.25 million tonnes and it can readily be expanded, while the Tunisian refinery will have 1.5 million tonnes. The Ghana refinery will have 1 million tonnes capacity; the existing Porto Marghera refinery is 51% owned by ANIC and 49% by B.P. Now Mr. Mattei has had permission for a new refinery in the north of Italy with a throughput of 2.5 million tonnes, plus a reserve of 30%. This refinery, for which a site has yet to be announced, may be connected with the pipeline from Genoa to Switzerland.

While at the San Donato headquarters of ANIC, I was interested to see the computer-controlled centre at which all flow-measurements on the vast oil and gas pipeline network which traverses the Po Valley are automatically controlled. This costly installation paid for itself in its first year of operation, replacing a system by which individual operators telephoned flow measurements to San Donato.

★ MY travels through Italy took me to many chemical companies and to the offices of many of Italy's top chemical executives. None was more impressive than Piero Giustiniani, who like many Italian industrialists is very much a humanitarian. With an impressive knowledge of world chemical and economic affairs, his views on the need for a 'bigger and better' Common Market are not merely those of a visionary, but of a man who sees that this is the only way to increase rapidly standards of living and of providing a cushion against the affects of the 'cold-war'.

Giustiniani is a chemical engineer who has risen to the top of the administrative tree. He is not the only such person in Montecatini, for one of the deputy chairmen, Ing. Giacomo Fauser, is known throughout the world for his work on ammonia synthesis. I was surprised to learn that Fauser was born in Italy—at Novara, where Montecatini have their

central research laboratories—and that he is still very active in this field. Incidentally, because of the lack of suitable constructional materials just after the first world war, one of Fauser's first high-pressure vessels for ammonia synthesis was the barrel of a war-time cannon.

His colleague Giustiniani has had considerable chemical engineering claims to fame for he designed and engineered the company's first p.v.c. plant in 1938. He has provided the initiative for the development of a number of new products, which have placed Italy among the most advanced countries in the field of plastics. As a managing director he became deeply involved in the organisation of the company in which he began his career exactly 35 years ago, as a manager of Montecatini's first plant of importance in Southern Italy.

It is men like these that have helped to make Montecatini one of the world's major chemical producers. Despite the big inroads being made into the Italian chemical industry by other groups, I have no doubt that Montecatini's solid background of achievement in research and development will help them maintain their position as Italy's leading chemical producers.

★ FOLLOWING the recent decision of the Netherlands Government to hive off the chemical interests of the Dutch State Mines, a public share issue is likely to be floated, possibly along the lines of that when the German Federal Republic denationalised Volkswagen. I would expect Royal Dutch Salt, a company that has expanded its chemicals production enormously in the past five years, to take up a large part of any such issue—maybe as much as 25%.

★ READERS must have boggled at the figures given for U.K. imports of vinyl acetate (as a footnote to the news of Hedon Chemicals' monomer plant extensions at Salt End, Hull) on page 763 last week. The figures were actually correct but the units were wrong—first-quarter 1961 imports of vinyl acetate monomer reached a value of £333,977, not a quantity of 333,977 tons. Similarly, the figure for the first three months of 1960 should have read £274,637.

The figures were taken from the Trade and Navigation Accounts, in which the change of units from one column to another is sometimes not immediately apparent when reading off figures quickly. The error was, of course, quickly spotted by readers who were aware that the present U.K. consumption of vinyl acetate

lies somewhere between 15,000 and 20,000 tons a year. It was recorded in C.A., 15 October 1960, p. 624, that the 1960 import total was than running at an annual rate of 7,800 tons.

★ AGRICULTURAL chemicals tend to receive more unfavourable than favourable publicity, and one of the reasons for this thinks Dr E. F. Edison, Director of Chesterford Park Research Station (see also p. 813) is perhaps that the industry is inadequately vocal on its own behalf. Firms within the industry can rarely justify spending much time or effort in arguing, usually quite fruitlessly, with those who are irrevocably convinced that the industry is an anti-social element of the human community.

This is far from the case, said Dr. Edison. Many useful and safe advances are occurring behind the scenes, and the problems created are infinitely small compared to the amount of good in terms of better food production that is achieved. The solution of the problem of world hunger will ultimately depend upon the correct and economic use of agricultural chemicals.

★ FIRMS exhibiting at the British Trade Fair in Moscow (see p. 809) certainly means business—Russian business. I.C.I. had 50 tons of literature specially printed in Russian for the occasion, while personnel manning the Distillers stand took a special course in Russian organised by the company. Staff on Marchon's stand have found an easier way round the language problem—they are helped by a recording machine which answers questions in Russian about the models displayed, and about Marchon's manufacturing activities and the domestic market in the U.K.

Quickfit and Quartz go a step further—they are giving away 1,000 records in Russian, featuring a discussion between a laboratory assistant and a chemist.

Among pharmaceutical exhibitors are Pfizer, who have taken the unusual step of producing a Russian language edition of their international medical review, *Spectrum*. I learn, too, that a number of stand personnel have been studying the 'Scientific Russian' course featured in *CHEMICAL AGE* last autumn.

★ NEWS reaches me from New York of a catalyst developed by W. R. Grace and Co. to control smog from motor exhausts. The culmination of more than two years' research by this catalyst has been used with a reactor muffler system, built by Norris-Thermador, Los Angeles, in road tests for more than 25,000 miles. The catalyst is said to reduce greatly the both smog-causing hydrocarbons and carbon monoxide when substituted for the standard muffler in the exhaust system.

Alembic

'Chemical Age' Interviews Montecatini's Giustiniani

Two-point Plan for Europe—A Bigger C.M., Plus Inter-company Agreements

WHILE the Queen and the Duke of Edinburgh learned something in Italy of that country's amazing industrial and economic progress, I heard from Ing. Piero Giustiniani, managing director of Montecatini, details of expansion in Italy's fastest growing industrial sector—chemicals, writes 'Alembic,' who was the Benn Brothers Group correspondent with the Royal Tour of Italy.

Ing. Giustiniani received me in his third-floor office at the Milan headquarters of Montecatini (Societa Generale per l'Industria Mineraria e Chimica, Anonima). A chemical engineer by training, he has been a driving force behind Montecatini's vast expansion projects in recent years. Montecatini are Italy's biggest chemical producers and have a number of new sites under development, the largest being at Brindisi, where a £40 million complex is now under construction. First plants are due on stream by the end of this year and the beginning of 1962.

A man of vision, Giustiniani is one of the 'New Europeans'—he is looking to a widening of the Common Market to include all of West Europe in one vast market. This he sees as the only solution not only to the problems of West European industry generally, but also to present a solid, united trading and economic bloc that could withstand any aggressive trade war on the part of East Europe.

Britain Must Join C.M.

Ing. Giustiniani told me "I am convinced of the necessity for Britain—and the other countries of West Europe—to join in the Common Market; we cannot have a united Europe without Great Britain. We need not only the tradition that Britain can bring, but also the equilibrium and stability." He was equally convinced that sooner or later the outstanding differences that have so far prevented a merging of European trade blocs will be resolved. When this merger comes about, the European market will be one of the largest in the world with a population of more than 300 million to serve.

Already the Common Market has meant a change of thinking when large companies like Montecatini are planning new developments. It is no longer good enough to think in terms of a domestic market only; the need is no longer for one 10,000 tonnes-a-year plant in Italy and another 10,000 tonne-plant elsewhere in Europe. Now the need is for one 20,000-tonne unit, not necessarily sited in Italy, but anywhere in Europe where the ideal location for raw

materials, transport, labour, etc., can be found.

Development along these lines, however, will call for a different approach to agreements between companies. As Giustiniani says the very notion of 'cartels' has been discredited, but there



Ing. Piero Giustiniani, managing director of Montecatini

is a vital need for agreements between companies if best use is to be made of raw materials, transport and distribution facilities. Such agreements would greatly help speed the development of the European chemical industry; some are already apparent, particularly in Switzerland, where the tradition of democracy is among the strongest in the world.

Ing. Giustiniani particularly mentioned agreements between Swiss chemical companies for their overseas activities, as being an example of how inter-company arrangements need not work against the public interest, but rather the opposite. He sees the possibility that any such agreements would be subject to conditions acceptable to all countries—the prime aim would be to see that the cost of chemicals, plastics, fibres, elastomers, etc., to the consuming industries and the public were the lowest possible.

Such agreements would also greatly help to rationalise production, an important step, for Montecatini's managing director sees little point in having a unified Europe if chemical companies are setting up plants in many different countries without regard to the needs of the market as a whole. It would be to the advantage of all, for instance, if there were more joint ventures, with Italian companies combining their skills with French chemical producers for certain projects, and similarly for French firms to enter into production agreements with their Italian counterparts for manufacture in Italy.

Such developments are permissible under the Treaty of Rome; it would, of course, be necessary to ensure that any agreements reached were in the best interests of the European community. If properly developed they would lead to

a "self co-ordinated distribution system" in the various countries of Europe.

Already there was a great deal of co-operation in Europe. Technical experts, research staff and sales representatives of the various companies are continually meeting at conferences, symposia and exhibitions. This continual exchange of ideas is what Ing. Giustiniani calls the "cement and mortar" for the new Europe. Further interchanges, including switching scientists and skilled labour from one country to another were part of the evolution towards a bigger Common Market—"the bigger, the better", for all companies would find their own levels in due course.

Asked whether he thought the present trend towards over-capacity in some materials would seriously affect the growth plans of Italian chemical companies, Ing. Giustiniani was convinced that consumption would continue to grow rapidly. The wider the area of the European trading bloc, the quicker would be the growth. Just after the war, consumption was slow to build up, but the past five years had seen a growth rate not thought possible 10 years ago.

Potential is Tremendous

The potential for further increases in Europe is tremendous for the per capita consumption in many European countries of such materials as textiles, synthetic fibres, plastics, etc., is negligible. As industry develops, so also will standards of living and the demand for newer materials.

As stated in CHEMICAL AGE last week, in our report of the Duke of Edinburgh's visit to F.A.O. in Rome, the world population will in the next 40 years double from the present 3,000 million to something like 6,000 million. Quite apart from the major task that faces the world's chemical industries—that of trying to raise the standard of living of the existing population, the task of housing, feeding, providing transportation, communications, medical services, etc., for another 3,000 million will mean unlimited opportunities for chemical producers.

Inevitably in any major new plant project, if the unit is to be of an economic size, there will be a period when part of the capacity is not being fully utilised. But by the time demand has built up, an expansion project is most likely ready to be put into action. In Ing. Giustiniani's experience, Montecatini have never had a plant in over-capacity for more than two years.

I then asked him what he thought of

the outlook for the Italian chemical industry. Although he thought it impossible to talk in terms of 'chemical industry' generally, he felt that the prospects for all the various sectors—organic, inorganic, plastics, fibres, rubber, etc.—were brilliant. The future of the Italian industry was bound up closely with the greater development of the European Common Market. In Italy itself, millions of people in the south have a low standard of living; the chemical industry will not only bring them new products, but a new way of life.

It was not possible to see clearly what products might form the really big developments in the years ahead, but there was no doubt that many new materials would find large outlets. Ing. Giustiniani told me that in May 1940, a few weeks before Italy's entry into the war, he visited I.C.I. in London. There he was shown a sample of a promising new material—polythene. Who would have thought then that within 20 years, U.S. production of polythene would have topped the 1,000 million lb./year mark?

A similar story is true also of p.v.c. Montecatini built one of Europe's first plants with a production of 50 tonnes-a-month, or some 600 t.p.a. Today their capacity is 70,000 tonnes/year and in 1962 will rise to 120,000 tonnes.

Today the Montecatini Group investment in petrochemicals represents 180,000 tonnes of carbon content. The new complex at Brindisi will, with the established plants at Ferrara, utilise the whole output of 1.5 million tonnes of crude—crude throughput is likely to be expanded to 2 million tonnes. None of it goes to the traditional petroleum outlets—petrol, paraffin, etc.; what is not used for steam and power consumption is or will be converted into chemicals.

Aromatics at Brindisi

As already announced, Brindisi will have a 30,000 tonnes/year plant for Moplen polypropylene, plus 30,000 tonnes of high-pressure polythene. Other major products will include refining derivatives, olefins, oxo chemicals, solvents, elastomers, plasticisers, etc. New products will include Montecatini's ethylene-propylene copolymers, for which a big future is seen, and their newer types of synthetic rubbers. Last but not means least will be a large aromatics unit. This will produce benzene, toluene and xylenes; Ing. Giustiniani said that a plant of up to 25,000 tonnes/year petroleum-based naphthalene is envisaged. This complex will be completely integrated and as a result phthalic anhydride and maleic anhydride will be produced as well as phthalate esters and plasticisers.

The site area at Brindisi is one of 650 hectares—four times bigger than the City of Brindisi. Other sites to be developed will include Bussi (organic chemicals) and Ferrandena, where large deposits of natural gas have been found. At Terni, it is planned to produce 800 tonnes/month of Meraklon polypropylene fibre; it is significant that Montecatini have already solved the problem of dyeing the fibre after spinning and work is in hand to improve the process.

With rapid expansion throughout the Italian chemical industry, one of the major problems facing Montecatini has been to lower production costs with a view to keeping sales prices at the lowest possible levels. Ing. Giustiniani believes that a misconception has grown up concerning Italian labour costs; these are said to be cheaper than anywhere in Europe. But he told me that if the cost of labour—like that of raw materials—was important, even more important were the high costs of investment and the provision of all the necessary services. In the final analysis, the cost of a product in Italy depends substantially on the charge of investment and amortisation.

Montecatini are proud of the fact that they have always been in chemicals.

First U.S. Space Capsule Carried MacLellan Rubber Tubing

THE space capsule that carried the first U.S. astronaut into space contained tubing made by the U.S. licensor of Flexible Ducting Ltd., a wholly owned subsidiary of George MacLellan and Co. Ltd, Glasgow, F.D. and their U.S. associates are engaged in the development of a number of special flexibles used in rocketry. Export orders received for other purposes in recent weeks have included those for tunnel ducting for Yugoslavia and Nigeria and air-conditioning flexibles for Teheran.

This was stated by Mr. Robin MacLellan, joint managing director, at a lunch held in Glasgow last week to mark completion of 10 years' hard work in the export field. In that period the group has earned well over £2 million in the export field, almost half of that being in dollars.

The group has spent more than £250,000 in rebuilding, in new machinery and in general development over the past few years. Mr. MacLellan stated it was only by continual technical development that they could make hoses to start jet aircraft, to ventilate foul air, to circulate clean air, or for work at extremely low pressures or for high pressure and high temperature usage.

During a tour of the works, it was stated that natural rubber varied so much that a synthetic rubber with all the properties of natural rubber would be greatly welcomed in the industry.

The Glasgow works manufactures rubber linings for bulk chemical tanks. These linings can withstand a wide range of temperatures as well as a great variety of products and with proper care should last up to 10 years. Some customers, however, when having tanks lined will often not specify the chemical involved; in these circumstances it is not possible to supply the most suitable type of lining.

Flexible ducting produced by the company ranges from $\frac{1}{4}$ in. to 12 in. diameter. Where insulation is required, such as in rocketry, polyurethane foam is employed; the new Vickers VC10 is being fitted with this type of insulated ducting. For vent-

Some of their major competitors spring from a different background—from shipping, the provision of electric power or oil, and have diversified into chemicals. This has presented difficulties to a company like Montecatini, says Ing. Giustiniani, whose products must include a margin of profit to cover heavy spending on research and development and on the provision of a big network of technical service.

To continue an expansion policy against such competition means a continual search for new products so that as competition swamps production in one field, the company can get into the market first with a new material. That is why Montecatini, pioneers in the development of copolymers, are confident of the future.

ing gases from oil tankers, the company supplies ducting lined with glass-fibre which rests on polyurethane foam.

The company's product range also extends to materials for protective clothing and alkali and acid-resisting clothing for the chemical industry.

New Granular Insecticide Demonstrated by Cyanamid

A new granular systemic insecticide—Thimet phorate—was demonstrated experimentally at the British Sugar Corporation's annual spring demonstration held at Norwich. The insecticide, developed by Cyanamid, is experimental, and trials are currently being conducted in various parts of the U.K. with a view to introducing it on a commercial basis at a later date. Although Thimet is already widely used in the U.S. and other countries, it has not yet been marketed in the U.K.

The use of Thimet granules on sugar beet is a completely new approach to the problem of aphid and Virus Yellow control. The insecticide requires no water and is distributed in one application only. It has a triple action; it is absorbed systemically through both roots and leaves and has a fumigant effect on application.

New Polarographic Instruments from Southern Analytical

Southern Analytical Ltd., specialists in instrumentation for chemical analysis, are staging an open exhibition at the Hotel Russell, Russell Square, W.C.1, between 10 a.m. and 5.30 p.m. on 19 to 22 June inclusive. Two new instruments will be introduced in the field of trace analysis and quality control by polarography. A number of other devices having applications in continuous control of suspended solids in liquids and gases, colour control, gas purification, dissolved oxygen measurement and electro-deposition, will be exhibited.

BRITISH CHEMICALS AND EQUIPMENT SHOW UP WELL AT MOSCOW EXHIBITION

AN all-out bid to attract new business for their products and service in the U.S.S.R. is being made by exhibitors at the British Trade Fair, Moscow, 19 May-4 June. Exhibitors include a number of chemical and equipment firms, some of whose exhibits are briefly noted below.

Chemicals. Post-war progress in petrochemicals is emphasised on the stand of the **Distillers Co.**, by a model of the petroleum cracking plant at Grange-mouth, which holds a central place on the stand. Control apparatus for D.C.L.'s continuous yeast process is shown for the first time. Antibiotics—D.C.L. sold 100 m. grammes last year—are well to the fore. Descriptive panels illustrate the production of plastics materials, acetic acid and other chemicals. A main objective is to sell not only products, but new industrial processes devised by D.C.L.'s research department. The stand is manned by key staff who took a Russian language course organised by the company.

A striking feature of the **Fisons** stand is a 17 ft. high illuminated golden ear of barley surrounded by giant insects, symbolising crop nutrition and protection. There are 19 factual display panels setting out the scientific development of new products as well as showing the end use of the main groups of products. Emphasis in the stand story is also given to Fisons extensive scientific research effort. Five of Fisons leading companies, Fisons Fertilizers, Fisons Pest Control, Bengel Laboratories, Whiffen and Sons and Loughborough Glass are exhibiting. Fisons also feature process know-how.

The double decker stand of **I.C.I.** covers 2,680 sq. ft., almost half of which is occupied by Dyestuffs, Plastics and Fibres Divisions between them. Dyestuffs Division highlight the Procion and Procilyn dyes, discovered by I.C.I. chemists and already in use in Russia. The Dyestuffs Division display emphasises their increasing use for textile dyeing and printing. In the non-dyestuffs field, in addition to the comprehensive range of high-quality accelerators, anti-

Two different approaches to stand design are those of I.C.I., with their 'double-decker', and the Distillers Company



oxidants, antiozonants and other rubber chemicals marketed by Dyestuffs Division, organic polyisocyanates and associated polyester and polyether reactants are also included.

Marchon Products Ltd. (of the Albright and Wilson Group) are displaying models of parts of the two fatty alcohol plants to be built in Russia, for which they have obtained a £3 m. contract in association with Constructors John Brown. The models will be shown against a background of the household and cosmetic products in which Marchon chemicals play an essential part, with special emphasis on tripolyphosphate and fatty alcohols and their uses in household detergents, shampoos, etc.

Although the Soviet Union is known to have begun making silicones, probably on a large scale, **Midland Silicones** (another Albright and Wilson company) point out that, with ten years' experience in this field, they can offer specialised silicones developed with the needs of industry in mind. With four publications specially written and translated for the occasion, Midsil are showing their full range of products.

A silver spanner on the stand of **Pfizer Ltd.** is a reminder of the link between Pfizer and Sir Alexander Fleming, discoverer of penicillin. The spanner was presented to Fleming when he inaugurated the first Pfizer fermentation tank

in Britain. Pfizer hope to interest the Russian medical profession particularly in their new antibiotics which help solve the problem of resistant strains of bacteria. Agronomists and veterinary surgeons will be interested in the wide range of animal feed supplements and veterinary products which Pfizer produce. Similarly Pfizer hope to obtain orders for their many fine chemical products, widely used in the food and plastics industries.

Magnesium compounds for industrial and pharmaceutical uses are featured by the **Washington Chemical Co.**, one of the four companies of the Turner and Newall Ltd. organisation who have a joint display at the Fair. Rubber, pharmaceutical preparations, printing ink, paint, plastics, electrical, soap, salt, paper, tanning and many types of thermal insulation—all of these industries and many more use Washington's Patintin's brand magnesium products. Special emphasis is being given on this occasion to the special grades of magnesium oxide which the company supply for the compounding of polychloroprene and other synthetic elastomers. Photographs show examples of the main fields of application for the Washington insulation materials which are applied by their associate company, Newalls Insulation Co. Ltd.

Equipment. The AEI MS7 spark source mass spectrometer, two of which have been ordered for nuclear research in the U.S.S.R., is exhibited by **Associated Electrical Industries Ltd.** This equipment is capable of detecting one part (atomic) in 1,000 million.

Conveyor belting, industrial hose, V-belts, p.v.c. pipes and fittings, mouldings and extrusion in natural and synthetic rubber and ebonite, are amongst exhibits by **BTR Industries Ltd.**

A new development featured on the stand of the **Cambridge Instrument Co. Ltd.** is their multi-point boiler water analyser, capable of recording on one

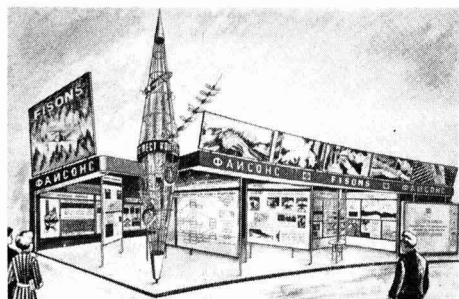

The 'golden ear of barley' symbol is prominent on Fisons stand

แผนกของสมมติ กรมวิทยาศาสตร์
กระทรวงอุตสาหกรรม

chart the results of up to 12 measurements of different variables in boiler feed water. The instrument displayed in Moscow is based on a 6-point recorder and provides sequential measurement of dissolved oxygen in the ranges 0-0.1 and 0-0.4 mg./litre; dissolved hydrogen in the range of 0-0.1 mg./litre; conductivity in the ranges 0-10 μ mhos and 0-100 μ mhos, and pH in the range 4-14.

Electronic instrumentation on the stand of **George Kent Ltd.** includes examples of the Mark 3 Multelec strip-chart recorder-indicator for the measurement of temperature, current, millivolts, O_2 , CO_2 , SO_2 , conductivity, flow (by the electromagnetic method), etc. There are also items from the new Transdata system—a range of compact and inter-related 'building blocks' from which to construct comprehensive measurement and process-control systems based on a common transmission signal in the range 0-10 mA.

Exhibits being shown by the **Morgan Crucible Group** include Purox recrystallised alumina, an impervious refractory of the highest purity, manufactured by Morgan Refractories Ltd. The Crusilite electric furnace element is being shown, as are resistors of various types, while a limited selection from the Morganite range of carbon engineering

'Chemical Age' at Moscow Trade Fair

Copies of 'Chemical Age' already widely read in the chemical industry and research institutes of the Soviet Union will be displayed on Collet's stand (Hall B, No. 6) at the British Trade Fair held in Moscow from 19 May to 4 June.

components also appears.

An eye-catching feature at the Fair is the 40 ft. high glass absorption column exhibited by **QVF Ltd.** as part of their display of glass plant and pipeline. Also on view are a 1-in. climbing film evaporator and a 100-litre steam-heated still. Sharing the QVF stand is their associated company, **Quickfit and Quartz Ltd.**, whose new apparatus on view includes an electrically heated automatic water still, a vapour-dividing fractionating head and glass vessels for continuous culture processes. Other Quickfit exhibits include open-necked reaction vessels, Kjeldahl equipment and semi-micro glassware as well as apparatus for extraction, evaporation, chromatography and fractionation.

Chemical Research to be Included at Pilkington's New Laboratory

STUDIES in solid state physics, organic and physical chemistry, metallurgy, statistics, electronics, and X-ray techniques are among the investigations which will be made at the new research laboratory of Pilkington Bros. Ltd., manufacturers of glass, at Lathom, near St. Helen's.

Believed to be the largest in the world, the laboratories were built and equipped at a cost of £2 million and the company intend to spend at least £1 million a year on development and basic research.

The laboratories consist of three main buildings of different sizes intended respectively for large-, medium- and small-scale experiments, as well as a number of ancillary buildings. Among these is the radiochemical research laboratory which is at present still under construction. In this building the effect

of radiation on glasses will be studied by means of the newest techniques available with the use of radioactive materials.

It is intended to employ 150 graduate scientists, and it was thought that it would take ten years to bring the staff up to strength, but it has proved surprisingly easy to attract scientists. Already, 100 have been recruited, and recruiting is being maintained at a rate of 20 graduates a year.

The range of Pilkington products includes sheet, polished plate and float glass. The development of the float glass process is perhaps one of the most revolutionary steps in glass manufacture. The glass is produced by floating liquid glass on molten tin, a process which yields a product which is said to combine the best properties of sheet and plate glass. The process was developed by Pilkington's at a cost of £4 million and seven years work.

Stainless Steel Road Tanker for Shell



One of 10 Scammell Highwayman 4,000 gall. stainless steel tankers recently supplied to the Shell Chemical Co. Ltd. The company have a fleet of 17 such tankers

Beck, Koller's Big Losses on Phthalic, Maleic Anhydride

THE drastic shortage of naphthalene which developed in the early part of 1960 obliged Beck, Koller and Co. (England) Ltd. to safeguard resin production by the purchase of phthalic anhydride at high prices. This was revealed in the annual statement prepared by the late Mr. W. H. Breuer, chairman and managing director of the parent company, Reichhold Chemicals Ltd. It was reported, however, that the supply returned to normal during the later months so that it was necessary to dispose of the surplus stocks at a substantial loss. Further difficulties were caused by the desperately short supply position developed in maleic anhydride.

In September the world supply position changed suddenly. Prices were rapidly reduced and supplies became much freer so that the Beck Koller Company were confronted with having to accept contracted deliveries at a premium, resulting at the end of December in writing off a substantial amount in respect of maleic anhydride stocks held at that time.

The stock losses on these two chemicals amounted to some £45,000. It was added that these factors are not likely to be repeated during 1961.

In Parliament

Purchase of Drugs on the Continent

Asked what the saving would have been if in the past year all supplies of chlorothiazide, tetracycline and chloroamphenicol, at £5, £37 5s and £27 per 1,000 tablets, had been purchased on the Continent, instead of from U.K. producers, Mr. E. Powell, Health Minister, on Monday said that about £350,000 on the estimated hospital usage. Purchase of those drugs on the Continent, however, would involve several issues, including that of royalty payments. Mr. Powell added that he was considering what guidance he could give to authorities on purchases abroad.

Gas Council Report on Methane Purchases

Mr. Richard Wood, Power Minister, told the House on Monday that he expected to receive the Gas Council's report on imports of liquid methane within "another few days".

U.K. Sulphuric Acid Consumption

In 6 May issue of CHEMICAL AGE, p. 726, it was stated that the consumption of sulphuric acid for phosphatic fertilisers was down and its use in titanium oxide production was up. The opposite in fact is the case. The error arose from the rather unusual arrangement of the table of consumption figures.

Canadian Tariff Hearing on Organics

CANADA DOUBLES INVESTMENTS WITH NO EXTRA PROFIT, SAYS C.I.L. PRESIDENT

THE Canadian Tariff Board, which is currently studying the Canadian chemical tariff structure, last week heard a plea from Mr. Peter C. Allen, president of Canadian Industries, Ltd. for the encouragement of the manufacture in Canada of organic chemicals, including synthetic resins and plastics.

As an incentive, Mr. Allen called for the establishment of a uniform and adequate level of tariff rates applicable to all organic chemicals. These rates of duty, he said, should be at a level to match the great potential importance of this industry to Canada. The alternative, he believed, is to rely increasingly on imports, with attendant ill effects on the balance of trade and employment.

Mr. Allen pointed out that organic chemicals lead to new ways of doing things and of doing things formerly impossible. They contribute notably to rising standards of living. Domestic manufacture of such products as the newer plastics, paints, synthetic rubbers and man-made fibres has also led to new industries and major extensions of established industries. This is of special interest to Canada at a time of serious unemployment.

Importance of Organics

The manufacture of organic chemicals, he said, increased the value of Canada's natural resources by using them as a raw materials. For example, petrochemicals manufacture increases the value of our petroleum resources, some of which would otherwise be burned as fuel, exported in the unmanufactured state, or flared off into the atmosphere.

Mr. Allen stated that a local source of supply was the surest, most convenient, and, in the long run, the most economical way of obtaining the increasingly important organic chemicals products for Canadian industry. In addition, it would help retain and give employment in Canada for chemists, engineers, and other technically trained persons whose knowledge and skills were needed for the best use of Canadian resources.

As an example of the world-wide increasing demand for organic chemical products, Mr. Allen cited the polythene which was discovered in England just before World War II. Today, world capacity for this remarkable plastics material, derived from oil or natural gas was more than 1,400,000-tons/year and this would rise to 2,700,000 tons/year in about 18 months when all plants known to be under construction are completed. This figure is of the same order as world production of lead or zinc and

about two-thirds of the world output of copper or of aluminium.

Mr. Allen expressed the belief that, without assistance Canada was likely to fall behind world trends of growth in organic chemicals. He pointed out that in recent years Canada had tended to lose her special advantages for investment in the chemical industry and that the rate of return on investment in that industry was steadily declining. For example, from 1948-1958 the rate of return on investment in the Canadian chemical industry had halved. That meant that the

industry had doubled its investment in 10 years for no return.

"Other places now offer equal or better opportunities for investment as a consequence our rate of growth may fall off", he said.

"In my own company, net income in 1960 at \$6.6 million is \$1.7 million less than in 1955 despite an increase of \$65 million or 46% in investment. In the same period, taxes calculated on a comparable basis increased from \$3.8 million to \$6.3 million, while dividends paid to shareholders remained stationary."

World Producers of Heavy Organics Find Canada an "Excellent Battleground"

SUGGESTIONS that there be no duty on certain products which Shawinigan Chemicals Ltd. make in Canada had already been submitted, declared Dr. H. S. Sutherland, president, at the Canadian Tariff hearing on heavy organics. "In later hearings," he said, "we shall support some reductions from current unrealistically high rates. In other cases, we shall support the case for increased duties where today no duty or very low duties exist. This particularly applies in the more highly manufactured chemicals and plastics." He felt that any downward exceptions should be limited as to time and be reviewed regularly as to their continuing validity.

Since World War II the synthetic organic chemical industry of the world had grown up. Many foreign countries had effective trade barriers, at first from necessity but now from choice. The

domestic markets had increased, but the now adult world producers found Canada to be an excellent battleground. Tariff protection on heavy organics was very limited indeed, and in some cases non-existent.

The need for more industrial research had been stressed by high government officials, and Shawinigan were prepared to do more, given the proper climate. But the low level of earnings not only discouraged investments, it also deterred research. Shawinigan, for example, last year spent \$642,000 on new products and new processes research, \$232,000 on research to improve existing processes, and substantial additional amounts on technical service research.

"It is my opinion," added Dr. Sutherland, "that we could have, profitably, done more research had our earning power been great enough to pay for it."

N.B.A. President is Re-elected

AT the annual meeting of the National Benzole and Allied Products Association, Mr. F. A. Jackman (Carless, Capel and Leonard Ltd.) and Mr. W. E. Cartwright (Benzole Producers Ltd.) were re-elected president and vice-president, respectively, for a second year.

The executive committee was elected as follows: Dr. M. Barash (East Midlands Gas Board), H. H. Bates (Benzole Producers Ltd.), L. W. Blundell (North Thames Gas Board), A. Bradley (National Coal Board, Headquarters), G. Hanna (Dorman Long (Chemicals) Ltd.), R. T. Hayes (United Coke and Chemicals Co. Ltd.), W. D. Holt (National Coal Board, East Midlands Division), C. J. Johnson (North Thames Gas Board),

J. E. Jones (South Eastern Gas Board), C. N. Kemp (South Western Tar Distilleries), M. J. R. Lane (The Lincolnshire Chemical Co. Ltd.), D. G. Moody (United Coke and Chemicals Co. Ltd.), W. A. Robinson (The Midland Tar Distillers Ltd.), A. Slater (The Stavley Iron and Chemical Co. Ltd.), C. J. Waller (Scottish Tar Distillers Ltd.).

It was also announced that Mr. A. K. Steel, who is shortly retiring as head of the By-Products and Briquetting Branch of the Carbonisation Department of the National Coal Board, was appointed secretary of the Association as from the 1 June 1961. He will succeed Mr. Cartwright, who has filled this position since the formation of N.B.A.

New Fisons' Formulation for Low-volume Spraying Has Low Evaporation, Good Adherence

A NEW development in spraying technique was announced last week by Fisons Pest Control Ltd. The Lovo formulation principle, as it is called, was developed at the Chesterford Park Research Station during a study of the physical problems of low volume spraying and is designed to meet a particular need.

In many areas and situations it is desirable to reduce the amount of water used per acre for spraying to the minimum capable of giving a satisfactory result. There are two strong economic reasons for this: water may not be freely available without long and expensive haulage; and spraying from the air may be preferable or even essential and the limited and expensive weight lifting power of aircraft makes it very expensive to carry unnecessary weight.

There are several difficulties that must be overcome if low volume spraying is to be effective. To obtain adequately uniform coverage of the crop, it is desirable to cut down the droplet size in the spray and so increase the number of drops per acre, but in cutting down the size, the distribution of the spray is increasingly dependent on largely uncontrollable and unpredictable air currents. This is particularly important in air spraying.

Retarding Evaporation

The object of the research which produced Lovo was to discover a formulation which would retard evaporation of the water used to carry the active ingredient and to ensure that the spray droplets leave an adherent and weather-resistant residue.

Evaporation of water can be reduced by the presence on its surface of a very condensed monomolecular layer of certain paraffinic substances, particularly long chain saturated alcohols. Alcohols, however, are expensive and saturated fatty acids are used instead, which, although they do not have as great an effect on evaporation as alcohols at their best, are quite adequate for the purpose. They can also be supplied in a formulation which makes them very much more available to the new surfaces as they are created.

To achieve adherence characteristics once the active ingredient is deposited on the plants is a tricky problem since the formulation must be sprayed in water and yet it must not retain its water soluble characteristics. This is achieved by use of basic amines in the spray liquor which keep the fatty acids in solution, but which are volatile so that, when the spray deposit has eventually evaporated, the fatty acid is left in its free state as an agglomeration of micro-crystals. These are formed on the leaf

and therefore key-in very satisfactorily to existing paraffinic crystals which are already firmly attached to the leaf cuticle in the form of natural waxes.

The development of a formulation of this type is always a compromise between the most efficient chemically and the most economic. The research at Fisons Pest Control has shown that problems, such as foaming, can be overcome satisfactorily and economically by use of stearic acid as the fatty acid and methyl dibutylamine as the volatile amine. It is necessary to use a tertiary amine since with primary and secondary amines complexing of the copper in the fungicides occurs. Dibutylamine is readily available and the methylation process is a fairly simple one.

At present three formulations are available as liquids which are mixed with the water in the spray together with the finely ground insoluble insecti-

cide or fungicide. Two of the formulations provide strong adherence and differ in that one is prepared for use in more temperate climates, but both are for insecticides. The third is designed for use with insoluble fungicides. Work is going on to develop modifications which will enable more convenient combined formulations to be supplied.

Apart from developing their compounds, such as Lovo, Fisons Pest Control have also produced formulations of active ingredients discovered by other companies. An example of this is Rogor, a formulation based on the low-toxicity systemic insecticide dimethoate, which originated in the laboratories of American Cyanamid and Montecatini. Montecatini developed dimethoate specifically for the control of olive fly, but the systemic properties of the insecticide were first demonstrated in the research station of Fisons Pest Control.

Similarly, a family of herbicides, the triazines, were developed by Geigy, a company with which the Research Station has collaborated for some time. Fisons have developed Simazine and Atrazine for work overseas. Carbyne, a control, for wild oats which was originated by the Spencer Chemical Co., is under investigation by Fisons Pest Control in large-scale trials throughout Europe and in Australia, Canada, New Zealand and the U.S.

Sulphur Institute Budgets for Use Research

RESEARCH and educational programme dealing with new and expanded uses for all forms of sulphur in industry and agriculture will be put into full operation during 1961-62, stated Dr. Russell Coleman, president of the Sulphur Institute, at the first annual meeting held last week (see also 'People in the News'). Although some research was started in the Institute's first year, the 1961-62 budget provides for a variety of projects to be conducted by public and private research organisations.

The industrial research programme will concentrate mainly on fertiliser technology and the use of sulphur in the construction and road building industries.

The Institute will continue its support of the programme of the Food and Agri-

culture Organisation to raise fertiliser consumption in underdeveloped areas. Studies will also be made of the economics of fertiliser producing processes and of probable trends in the next five years in the kinds and amounts of fertilisers to be used.

In agriculture, studies will deal mainly with the use of sulphur as a plant nutrient. A number of projects are scheduled to assess the sulphur needs of soils in various parts of the world, including Europe, the U.S., South America, Australia and India. Also to be studied is the role of sulphur in tropical oil crop production. Other investigations will have as their main aim the development of suitable soil and tissue tests to help predict sulphur needs of crops.

London Symposium on Process Control

ON 13 and 14 June, Elliott Brothers (London) Ltd., a member of the Elliott-Automation Group, are holding a private symposium and exhibition on analytical instrumentation of industrial process control at the Connaught Rooms, London.

At the symposium, papers will be read by Mr. K. E. Hallikainen, president of Hallikainen Instruments, Berkeley, Cal., on 'The application of analysis instruments in the U.S.' and by Mr. D. J. Fraade, head of the applications laboratory of the Analytical and Control Division of Consolidated Electrodynamics Corporation, Pasadena, Cal., on 'The continuous measurement of moisture'.

Papers will also be read by Mr. L.

Farey, of Mobil Oil, on 'Analysis Instruments from the point of view of the user' and by Mr. J. Mawson on 'Experience with plant stream analysers at I.C.I., Billingham'. Mr. T. R. Mills, chief engineer of the Analytical Instruments Division of Elliott Brothers (London) Ltd., will speak on 'Trends in continuous process analysis'.

A wide selection of the extensive range of quality control instruments supplied by the Analytical Instruments Division of Elliott Brothers (London) will be exhibited.

For further information: John Geddes, Elliott-Automation Limited, 34 Portland Place, London W.1.

Marginal Rise in Wholesale Chemical Prices

THE Board of Trade wholesale price index for April shows a marginal rise in sales prices of the chemicals and allied industries, from 103.7 in March to 103.8 in April, the index being based on a 1954 monthly average of 100. However, in April 1960 the index stood at 104.7, so that the index for chemicals is still below the level of a year ago. It appears that the increase is partly due to higher prices ruling for paint.

The following is an extract from the index.

	April 1960	March 1961	April 1961
Chemicals & allied industries			
Total sales	104.7	103.7*	103.8*
Home sales	106.5	105.4*	105.6*
General chemicals	105.0	103.9*	103.9*
Pharmaceutical chemicals	81.4	80.8*	80.8*
Pharmaceutical preparations	101.1	99.4	99.3*
Paint	108.4	109.0	109.2*
Soap	128.8	129.6	129.6*
Soapless detergents	103.6	103.6	103.6
Synthetic resins & plastics materials	89.5	86.9	86.6*
Commodities Wholly or Partly Imported			
Pyrites, c.i.f. U.K. ports	64.2	61.5	61.5
Sulphur, crude (for acid), c.i.f.	75.6	71.7	71.7

Quickfit to Intensify Technical Research

A NEW Quickfit and Quartz Ltd. research and product design department will intensify research into development of new products, and improvement of existing ones. This is part of a reorganisation of the firm's research and development activities.

The product design section will be under the management of Mr. W. J. Clarke, assisted by Mr. W. E. Brown, design engineer. The physical standards section will be under the management of Mr. G. P. Helliwell.

Quickfit have also set up a production method improvement department, with Mr. D. H. Wakefield, production method engineer, as manager.

New Members for Lab. Ware Association

T. Gerrard and Co. Ltd., 46-48 Pentonville Road, London N.1, and Mr. A. D. Wood, 4 Skinner Street, London E.C.1, have been elected ordinary members of the British Laboratory Ware Association. New associate members are Amal Ltd., Holdford Road, Witton, Birmingham 6, and Deeley and Co. Ltd., 1 George Street, Balsall Heath, Birmingham 12.

U.K. TEL Consumption Continues to Rise

Consumption of tetraethyl lead in the U.K. totalled 6,894 tons in the first three months of this year, compared with 5,250 tons in the same period of 1960.

ANIC Start Construction at New Gela Petrochemical Complex

DURING 1960, ANIC of the State-owned ENI oil group, and their associates concentrated on refining, petrochemicals and fertilisers, relinquishing other activities. Thus their fats processing plant at Novara as well as their shares in ACSA, who produce sensitised paper, have been dropped. No longer interested in building a refinery near Rome, ANIC have given up their participation in Soc. Raffineria di Roma.

During the year construction was started on the petrochemical complex at Gela, facilities at Ravenna were expanded and the carbon black plant to be operated at Ravenna by Phillips Carbon Black Italiana is nearly completed. During the year the vinyl chloride monomer and p.v.c. plants to be operated by Soc. Chimica Ravenna, owned in co-operation with Wacker Chemie GmbH were completed, the polymerisation unit came on stream this month.

New petrochemical plants are to be constructed in the Valley of the Bassento to utilise 600,000 cu. m. of methane a day from the deposits recently discovered at Ferrandina. Initially, intermediates for

plastics will be produced with production of synthetic fibres to be added later.

With a balance sheet profit of Lire 2,025,869,204 for 1960, ANIC during the year raised their capital to Lire 500 million.

At Ravenna, plant for the production of butadiene from butane and of urea came on stream, while a third unit has been added to the existing GRS rubber unit. Plant for the production of rubber latex is in hand and a new polybutadiene plant came on stream this month. The annual report states that the whole of the output of rubber (some 80,000 tonnes) and fertilisers (around 1 million tonnes) produced at Ravenna were successfully marketed.

Work of designing the Gela plants is in hand at SNAM Progetti's offices at the ANIC headquarters at San Donato Milanese. Under construction are plants for ammonia synthesis and polythene, while orders have been placed for plants that will produce petrol, gas oil, fuel and intermediates for petrochemicals. Other plants have yet to be specified by ANIC.

Sicedison's Expansion in Petrochemicals

THE Mantua olefin plant of Sicedison increased its capacity considerably beyond the figure originally planned, it is stated in the annual report. This is partly due to design features and partly to improvements in processing. Expansions have taken place in the production of monomer styrene and polystyrene as well as in detergent intermediates. Plants for the production of phenol and acetone from cumene are now gradually coming on stream, while construction of a maleic anhydride plant is at an advanced stage.

A new plant for the production of sodium cyanide from prussic acid has been commissioned at Porto Marghera, where a fluorocarbon plant, now at an advanced stage of construction, is expected on stream this year. A caprolactam monomer plant at the same site is expected on stream this year.

Economic results of ICPM (Industrie Chimiche Porto Marghera) are stated to be not yet satisfactory. Attempts are being made to introduce into Italy new products such as hydrofluoric acid. One production unit for Leacril acrylic fibre is in operation at Porto Marghera, but other units are being added while the market is being developed.

Stiff competition was met in fertilisers during the year.

Last year, SINCAT completed the construction at Priolo of a cracking plant to process liquid hydrocarbons fractions to olefins, particularly ethylene and propylene. Part of the ethylene is used for the production of solvents, while propylene goes for the production of tetramer propylene and cumene-phenol. Most of

the ethylene is used by CELENE for the production of high-pressure polythene. SINCAT are now putting to work new plant for the separation of butadiene from LPG, a by-product of the olefin cracking unit.

This company's Santa Caterina, Sicily, potash mines yielded some 100,000 tonnes, a big increase on 1959. The associated processing plant at Priolo is being expanded.

CELENE built the first processing line for the production of polythene in 1960 and this is now being expanded to give capacity for 30,000 tonnes/year. Construction was continued of plants for the production of ethylene, ethylene glycol and other ethylene oxide derivatives.

Sicedison have now been authorised to increase capacities of their petrochemical plants from 200,000 to 400,000 tonnes/year. Sales in 1960 were 40% up on 1959.

Road Tanker Take-over in N. Ireland

The increasing importance of the chemical and allied industries in N. Ireland is reflected in the recent acquisition by Coast Lines Ltd., of the road tanker fleet of about 80 8-wheeled rigid and articulated vehicles of James Hemp-hill Ltd., Glasgow. This company is probably the largest private road carrier of liquid chemicals in bulk in Scotland.

Coast Lines during the past few years have taken over a number of road haulage companies.

I.C.I. Bin System Speeds Fertiliser Distribution

EXPERIMENTS by I.C.I. aimed at finding a more efficient way of handling and distributing bulk fertilisers has resulted in the development of a system which involves the establishment of bulk stores combined with contracting services using portable bins to get the fertiliser to the farms. The bin system was invented by Scottish Agricultural Industries Ltd., a subsidiary of I.C.I. and they have used it successfully for three seasons in Scotland. The same bins were tried last year successfully in Dorset and their use has been extended this spring to the whole of South-West England where a network of bulk stores and contracting services has been established to handle fertiliser shipped from Billingham.

The bin system requires a bulk store from which the three bins, each holding two tons and loaded on a lorry are filled mechanically by a conveyor. On arrival on the farmer's premises the lorry driver raises each bin a few inches off the lorry with a portable jack and then lowers special adjustable legs fitted on each side of the bin. These legs reach to the ground so that the lorry can drive away leaving the bins in position.

The contractor's fertiliser distributor can then back up to and under the bins from which it is filled by gravity feed through a simple shutter. It is then ready to drive away and start spreading.

The system is of particular value to the big farmer because it does away with the handling of fertiliser in sacks.

Harwell Develop Process to Convert Radioactive Wastes into Glass

DISPOSAL of radioactive wastes is a problem which will become more and more acute as the industry develops. It is estimated that by the year 2000 it may well be necessary to dispose of one ton of waste daily.

Suitable methods for storing radioactive wastes must allow for the dissipation of heat generated as well as provide a radioactive shield. One of the methods that has been considered is to turn the waste into a glass, so providing a hard, dense, compact solid which is strongly resistant to chemical breakdown by large radiation doses.

For some time, the Chemical Engineering Division at Harwell has been experimenting with a suitable glass to

serve this purpose. They are at present completing the design of a pilot vitrifying plant for the production of a glass from radioactive waste which will allow it to be stored for 500 years with a minimum of supervision. It is hoped that the plant will be working by next year and it is expected to provide information to enable the Atomic Energy Authority to decide whether or not to build a full size plant.

The glass is made from a mixture of radioactive waste, nitric acid and a slurry of silica and borax. This is evaporated at red heat so that it sinters and melts. On cooling a glass is produced which may contain 20 to 30% of its weight in waste oxides.

European Chemical Engineering Congress

PROGRAMME of the third congress of the European Federation of Chemical Engineering has now been completed. It will include an international symposium, arranged by the Society of Chemical Industry on 'The physics and chemistry of high pressures'. This symposium will mark the retirement of Professor D. M. Newitt, F.R.S., from the Courtauld Chair of Chemical Engineering, London.

The symposium will cover theoretical, experimental and applied work on pressures upwards of about 1,000 atm. Subjects will include changes of phase, study of optical, electrical and other physical properties, equilibria and rates of chemical reactions, and work on new techniques, equipment and design. Work on transient properties, such as explosive and shock-waves, will not be discussed.

The complete programme of the congress will now be: Meeting on 'process

optimisation' (20 June); meeting on 'Interaction between fluids and particles' (21, 22 and 23 June); symposium on 'The handling of solids' (25 June); symposium on 'The physics and chemistry of high pressures' (26, 27 and 28 June).

The congress is being held in conjunction with the second Chemical and Petroleum Engineering Exhibition, which will take place at Olympia, London, from 20 to 30 June, 1962.

Insecticide and Fungicide Conference at Brighton

The British Insecticide and Fungicide Conference of the Association of British Manufacturers of Agricultural Chemicals is to be held at the Grand Hotel, Brighton, from 7-9 November. This is the first conference of its type to be held and enquiries should be addressed to the conference secretary, Mr. W. A. Williams, Cecil Chambers, 86 Strand, London, W.C.2.

Additions to Approved Agricultural Chemicals

THE third list of additions to the 1961 list of approved agricultural chemicals has been issued: DDT/gamma BHC (Lindane) wettable powders, 'Gammalin' plus D.P.—Plant Protection Ltd.; fluoroacetamide sprays, Vitax-F15—Vitax Ltd.; Kelthane atomising solutions, aerocide kelthane—Pan Britannica Industries Ltd.; Rhothane wettable powders, Rhothane wettable—The Murphy Chemical Co. Ltd.; Dinocap (Karathane) wettable powders, Karathane wettable—Pan Britannica Industries Ltd.; organomercury-sulphur foliage sprays, Bugges sulpham—Bugge's Insecticides Ltd.; Zineb wettable powders, Bugges Dyblite wettable powder—Bugge's Insecticides Ltd.; Tizene blue—Profarmer Ltd.; chlorpropham (CIPC) sprays, triherbide CIPC—F. Bos Ltd.; 2,4-dichlorophenoxybutyric acid (2,4-DB) alkali metal salt sprays, Marks 2,4-DB—A. H. Marks and Co. Ltd.; MCPA alkali metal salt sprays, Eureka MCPA selective weedkiller—Plant Protection Ltd.; 2,4,5-T-2,4-D ester sprays, Spontox, Sylvitox—May and Baker Ltd.; dichloropropane/dichloropropene mixtures, Shell D-D soil fumigant—Shell Chemical Co. Ltd.

New Quickfit Apparatus for Moscow Fair

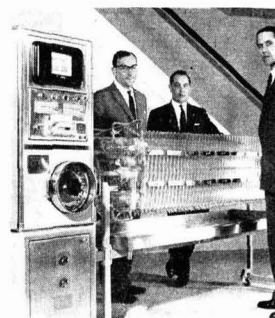

This fully automatic steady state distribution machine, the first machine to be produced by the recently-formed instruments division of Quickfit and Quartz Ltd., will be shown this summer in Moscow and Frankfurt. The machine has wide applications for continuous preparation of gramme to kilogramme quantities of materials which are difficult to separate or are labile, particularly for research dealing with materials of natural origin.

Petroleum Products as Chemical Feedstocks

Figures issued by the Petroleum Information Bureau show that a total of 1,562,060 tons of petroleum products were consumed as chemical feedstock during 1960. This is an increase of almost 500,000 tons over the 1959 figure.

Indian Newsletter

INDIA SETS SIGHTS ON TARGET OF 1 MILLION TONS OF NITROGEN

UNDER India's third five-year plan, launched on 1 April this year an annual production of 1 million tons of nitrogen by 1965 is aimed at as against the second plan (1960-61) target of 375,000 tons. The Government-owned units being established at Nangal (Punjab), Trombay (Bombay), Rourkela (Orissa), Neyveli (Madras) and Nahorkatiya (Assam), will together take care of four-fifths of the targeted production, the balance being made up by privately owned units. The expansion plans are estimated to involve an outlay of £150 million.

Government-owned Fertiliser Projects. The Nangal fertiliser project near Bhakra Dam in the Punjab started initial operations at the end of February. The £22.5 million factory is scheduled to attain an annual production of 200,000 tons of ammonium nitrate in August. In admixture with powdered limestone, the product will be marketed as nitro-limestone containing 20% N.

The Trombay fertiliser project is due for completion during the latter half of 1963, while a detailed project report has been prepared for the Nahorkatiya fertiliser factory based on natural and associated gases. This would be designed to produce 32,500 tons/year of nitrogen to meet the local needs of Assam. The end products would be 50,000 tons/year of urea and 50,000 tons/year ammonium sulphate. Tenders for the main plants are to be invited from exclusively British firms as the U.K. Government has offered a sterling loan for meeting foreign exchange costs of the project.

Rourkela Fertiliser Plant

The fertiliser plant at Rourkela (Orissa State) which is an adjunct to the 1 million tons West German Demag L.D. steel plant, is making good headway. The £15 million project likely to go on stream in 1962 would yield 100,000 tons of ammonia (80,000 tons N) per annum and will be converted to nitro-limestone (20% N) as at Nangal Fertilisers. Uhde of West Germany have contracted to supply and erect the plant for processing coke oven gas into ammonia. Construction of ammonium nitrate and nitro-limestone plants and all other auxiliary services have been entrusted to Sindri Fertilisers Ltd., the State-owned ammonium sulphate factory (capacity 70,000 tons nitrogen) at Sindri (Bihar State).

Work on the £37.5 million integrated Neyveli project in the State of Madras has suffered some delay on account of the stringency of foreign exchange. The first consignment of machinery and equipment supplied by the Italian firm, Ansaldo and Pintsch Bamag Linde (PBL) of W. Germany has arrived.

Raw lignite will be gasified in Winkler type gasifiers and ammonia synthesised by the Montecatini process. The urea plant, when completed in 1962, would contribute 70,000 tons of nitrogen annually to the domestic supply of fertilisers.

The Andhra Government is still nego-

The first part of this Newsletter, (C.A., 6 May, p.731) discussed recent major developments in the chemical and related industries in India. This second part deals with India's current plans for boosting fertiliser production

tiating collaborative terms for its gypsum-based fertiliser plant at Kothagudam. The West Bengal Government, following breakdown of negotiations with the Japanese firm, Mitsui Bussan, are now making efforts to secure collaboration of American firms. Meanwhile the Gujarat Government is following up proposals with New Delhi for setting up a fertiliser plant based on Ankleshwar gas. Gorakhpur in U.P. State is also being considered as a site for a Government owned factory.

Private Sector. In the private sector, the International Minerals and Chemical Corporation and California Chemical Company, and the East India Distilleries/Parry Group of Indian Companies have been licensed to construct the £18 million fertiliser plant on the East Coast of

India at Visakhapatnam where the Caltex refinery is located. The plant will produce about 350,000 tons of chemical fertilisers annually. Complete feasibility studies will shortly be undertaken and on the basis of these studies the American consortium will proceed to implement their decision in consultation with the Government of India.

The International Minerals and Chemical Corporation has been interested in India's fertiliser needs for some time and teams of agronomists, economists and engineers have visited India to study the situation in the past 18 months.

In Uttar Pradesh, the foundation stone of a superphosphate factory was laid recently at Magarwara, near Kanpur. The factory is the latest venture of Rallis Chemicals Ltd. in the field of fertilisers, and is licensed to produce 50 tons/day of sulphuric acid and 60,000 tons/year of superphosphate from rock phosphate and sulphur, both of which will be imported for the present. The capital outlay is approximately £450,000 million. Fisons of Felixstowe, U.K., will provide technical advice. The construction of the plant has been entrusted to Simon-Carves Ltd. and it is expected to go into production by January 1962.

Proposals in regard to technical collaboration and other details of the Hanumangarh factory (Rajasthan State) and other private sector projects are still under review.

Fertiliser Imports. Meanwhile, to meet the existing shortfall between fertiliser production and requirements in the country, the Government of India have completed arrangements to import 236,000 tons of fertilisers through the agency of private firms. The imports comprise: ammonium sulphate, 85,000 tons; urea, 98,000 tons; ammonium sulphate-nitrate, 30,000 tons; and ammonium nitrate, 23,000 tons.

Du Pont Elastomer Course at Hemel Hempstead

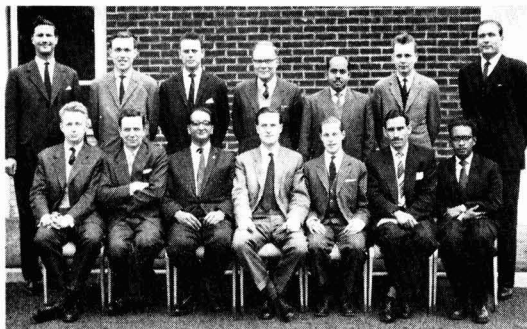

Eight representatives of some of Du Pont's elastomers distributors from Europe and Asia, together with members of the Du Pont Company (United Kingdom) Ltd., photographed during their two-week training course at the Du Pont elastomers research laboratory at Hemel Hempstead, Herts. Back row, l. to r.: G. B. Oks (U.K.), T. Köhler (Germany), W. Nielsen (Denmark), K. H. Whitlock (U.K.), D. C. Vermas (India), L. Nyberg (Sweden), J. P. Peters, Du Pont de Nemours International S.A. Front, l. to r.: C. Guyotot (France), J. N. Milne (U.K.), A. Dattoo (Pakistan), D. J. B. Coulter (manager, elastomers research laboratory), L. Mundet Gomes (Portugal), A. Fiber (U.K.), J.G. Thopil (India)

A.C.S. National Meeting

I.C.I.'s New Route to Silicones from Silaceous Materials

THE development of a direct route from silica and silicates to organosilanes and thence to silicones was described by Dr. R. C. Anderson and G. J. Sleddon of I.C.I. at the 139th American Chemical Society national meeting. The process consists essentially of reacting silica or a silicate with an alkyl aluminium halide either in an open system or in a sealed vessel.

In the open system method, the alkyl aluminium halide (for example $(\text{CH}_3)_3\text{Al}_2\text{Cl}_3$) is passed through a stirred silicate like bentonite clay in a heated reactor. A 74% yield of trimethylsilane is produced at 275°C. Alternately, tetraethyl and tetramethyl silanes can be made in a better than 70% yield by heating a silica suspension in a molten complex of alkyl aluminium dihalide.

An even more direct route is achieved by carrying out the reaction in a sealed vessel. Ethyl or methyl aluminium chlorides react with a dried silica gel or a silicate in a sealed system to give a mixture of the corresponding alkylchlorosilanes.

The various silaceous materials show a marked difference in reactivity. Sand is unreactive, but dried silica gels, acid extracted bauxitic clays and kieselguhr are all reactive. Silicates with open structures such as clays are generally more reactive than feldspars and similar compact silicates.

Polyester Resins from Trimethylene Glycol

POTENTIAL as a useful raw material for the production of unsaturated polyester resins is shown by trimethylene glycol. When used in the place of the conventional glycol components, it can be

made faster than the usual resins and is more flexible and resistant to u.v. light.

Although trimethylene glycol has been available for many years as a by-product of soap manufacture, it is expensive and difficult to purify. Recently, however, Shell Development have discovered a way to make trimethylene glycol from acrolein.

Advantages of using trimethylene glycol as control include a decreased loss of glycol—0.5% compared to 1.3% of ethylene—propylene glycol, and process time drops about 20% even though there is less trimethylene glycol excess.

Polymer Possibilities of Metal Chelates

CERTAIN chelate rings which behave like reactive, pseudo-aromatic systems may show the way to intermediates for making non-crosslinked chelate polymers.

According to studies carried out at the University of North Carolina, chromium (III), cobalt (III) and rhodium (III) acetylacetonates can be acetylated, halogenated, formylated and nitrated in typical aromatic electrophilic substitution reactions.

It is the formylation reaction which is particularly interesting since it leads to the formylation of one ring and to the deactivation of the other two. However, the unsubstituted rings remain active to other reagents and can be nitrated readily. This provides a route to a variety of mixed ligand complexes. It is the mono- and difunctional chelates prepared in this way which may be intermediates for making non-crosslinked chelate polymers.

Parke, Davis Install Unique Capsule Plant

A CAPSULE-MAKING plant capable of producing 400 m. capsules annually, has been brought into production by Parke, Davis and Co., Hounslow. Costing £500,000, the plant contains equipment unique in Europe in design and output.

Each capsule-making machine (costing £100,000) is fitted with 750 pairs of bars bearing a total of 22,500 mould pins. Cap and body d'shes are separate and 150 pairs of cap and body pins are dipped in one operation. Other machines fill, seal, polish and print on the capsules.

After manufacture and preliminary scrutiny, each capsule is inspected twice by workers who examine the capsules over an illuminated panel in a darkened room, at a rate of up to 30,000 an hour.

The plant occupies 18,000 sq. ft. and employs a staff of 65. It is air-conditioned, a complete air-change taking place every 7-8 minutes. All Parke-Davis capsule requirements are met by the plant, while a proportion of output is exported.

Laboratory Extension

Work has started on a £150,000 extension to the research and development laboratory at Barry, Glam. of Midland Silicones Ltd., a member of the Albright and Wilson Group. The extension will duplicate a similar block erected in 1959 and the two will be linked by a bridge. It is understood that a third research block is planned.

Letter to the Editor

Use of China Clay as Rubber Filler

SIRS.—I write to you with reference to the article on page 540 of the 1 April issue of your journal which gives details of a new rubber filler, called Blancomilo, available from F. W. Berk and Co. Ltd.

I should like to point out that this article is rather misleading where Blancomilo is compared with china clay. It states that the tear strength of a mixture containing Blancomilo "was found to be 20 lb. (B.S. 903) or nearly double the average of two mixtures in which Blancomilo was replaced by commercial china clay". As the largest producers in the world of china clay, our Research and Development Laboratories have made extensive tests of our clays in rubber mixes. Results have shown that china clays which we recommend for rubber fillers, when compounded as described have a tear strength of about 18-22 lb. A clay which would give results such as are described in the article would be a very poor grade indeed, and one that we should not recommend for use as a rubber filler, nor, indeed, would we be likely to market such a clay.

Yours, etc.,

N. R. LEONARD,

Advertising and Publicity Manager

English China Clays Ltd.,
St. Austell.

Patent Office Explains Specification Delays

MORE than half the complete specifications to be examined come from abroad, so reveals the Patent Office Report for 1960.

The Comptroller-General referred in his report to the public comment about the amount of time it takes to obtain a patent. He points out that although the initial delay in the Patent Office is still too long, the Office is not responsible for the 3 to 3½ years after the filing of the completed specification which is often quoted as the time needed to obtain a patent. If the applicant deals promptly with questions raised by the Office, an application can be accepted and published in 18 months; 50% of the applications are in fact accepted within two years.

J.M. Develop Zone-Refined Germanium

IMPORTANT developments in connection with their work on germanium are announced by Johnson Matthey and Co. Ltd., 73-83 Hatton Garden, London E.C.1.

Zone-refined (500Ω-cm, n-type) germanium is now available, normally in ingots having a nominal weight of 1 kg. A large scrap-recovery plant has been installed which enables a wide variety of types of germanium-bearing residue to be processed. The company now wishes to purchase large or small quantities of germanium scrap, and will be pleased to hear from any organisation having such material for disposal.

Overseas News

GRACE OVERSEAS PLANS INCLUDE NAPLES PLANT FOR SB RESIN AND LATEX

FIRST step in the plans of W. R. Grace and Co., New York, to produce organic chemicals overseas will be a butadiene-styrene resin and latex plant in Naples to serve Italy's rubber, paper coating and paint industries. Grace have outgrown their present container compound plant at Naples; they are building a larger factory near there which will also produce other chemical specialities.

Atsugi, Japan, will be the site of a new container compound plant, the company's first industrial operation in that country.

Expansion is also in hand in South America and construction will start soon of a plant near Bogota to produce phthalic anhydride and plasticisers, now imported, as well as to raise production of naphthalene, cresolite and pitch now produced at the Grace Carboquímica plant. The Buenos Aires plant has completed an installation to produce 19 million battery separators a year, using locally-produced fibre and resins. In Sao Paulo, Brazil, facilities have been completed to manufacture Cryovac packaging bags and film.

Japanese Firm Developing Own Naphthalene Process

The Japanese firm, Hokkaido Tanko Kisen Co., have been studying the manufacture of naphthalene by coal liquefaction. Recently they have succeeded in establishing their own technique.

Previously the manufacture of naphthalene from this source had been studied by the Miike Gosei Co. but, although they are continuing their research, they have changed over to the production of naphthalene from petroleum. If the Hokkaido process proves attractive Miike Gosei will consider changing to coal.

Mobil Aid for Planned Taiwan Urea Plant

Chinese Petroleum Corporation, Taiwan, are reported to be planning a petrochemical project in Nationalist China together with Mobil Chemical Co., U.S. A chemical plant with an annual output of 100,000 tonnes of urea would be built alongside a mineral oil refinery should the Nationalist Chinese Government consent.

Saint-Gobain Plan Expansion in Petrochemicals

The French company S.A. des Produits Chimiques Shell-Saint-Gobain plan to take up new petrochemical production, it is announced in Paris on the floating of a conversion loan totalling Fr.86,923,600 by Compagnie des Produits Chimiques et Raffineries de Berre, the company which looks after Saint-Gobain mineral oil and petrochemical interests.

The amount raised by the loan will be used for the Shell-Saint-Gobain petrochemical expansion project, as well as for the polybutadiene production plants of Société des Elastomères de Synthèse, who are soon to bring their new synthetic rubber plant on stream, the share of Compagnie de Raffinage Shell-Berre in the cost of the Mediterranean-Upper Rhine oil pipeline and the planned Strasbourg oil refinery and the continued mineral oil exploration of Compagnie des Pétroles du Sud-Est Parisien. (See also "Commercial News").

Hydrogen Peroxide Plants Sought in Spain

The Spanish Government has been approached with an application to erect a plant in Spain with an annual capacity of 4,500 tonnes of hydrogen peroxide. Applicant is Peroxidos, a local company still in formation and to have its seat at La Zaido, in Saragossa. Capital will be of Pesetas 100 million, of which 20% will be put up by non-Spanish interests.

Aluminium Will Be Montecatini's Third Indian Project

An agreement has been signed between Madras Aluminium Co. Ltd. and Montecatini, Milan, for the construction in Madras of a plant for the production of aluminium, utilising local bauxite deposits. Capacity is scheduled at 10,000 tonnes/year. This is the third Indian plant in which Montecatini are co-operating. The other two have been built at Neyveli and Sindri for the production of chemical fertilisers.

Mitsui Introduce Distillation Column for Cumene Plant

To meet the increasing demand for phenol and acetone produced by the cumene process, Mitsui Petrochemical Co. have decided to adopt a special distillation column of the Stone and Webster type.

The company will increase their plant capacity to 3,000 tonnes a year of phenol and 1,200 tonnes a year of acetone.

The technical tie-up between Mitsui and Stone and Webster has been submitted for approval. The ripple tray column will be adopted for phenol distillation. This type of distillation has the advantages over the existing blubber type tray or the perforated plate tray of cheaper installation costs, and that fluctuating loads have a constant plate efficiency and less pressure drop.

U.S. Report Two New Oral Contraceptives

Details of oral contraceptives for men and women have come from the U.S. The one for women, known as chloramphene, differs from other oral contraceptives at

present undergoing trials in that it does not suppress ovulation. Its action appears to lie in inhibiting the development of recently fertilised ova. Experimentation so far has been confined to animals. The results suggests that chloramphene is an effective contraceptive and that its effect is reversible.

If trials in human beings confirm the findings on the animals it is claimed that the drug will have an advantage over other oral contraceptives in that it would need to be taken only over a short period of time instead of 20 days each cycle. This would consequently cut down the cost.

For a number of years attention has been concentrated on achieving contraception by inhibiting ovulation in the female. There is no reason why attempts should not be made along the same lines in inhibiting spermatogenesis. In fact, reports have come from New York that Cornell University Medical School is testing a contraceptive pill for men. It is claimed that a daily pill ensures sterility, which returns when the pills are discontinued.

New Plant to Meet Detergent Demand in Japan

The Kao Soap Co. is planning the construction of a new synthetic detergent plant in order to keep pace with the increasing demand for detergents in Japan. The capacity of the plant, which is to be built in the Kanto, will be 3,000 tonnes a month. Kao already have a plant of a similar capacity at Wakayama.

Du Pont Seek New Swedish Site

E. I. du Pont de Nemours and Co. have applied to buy a 60,000 sq. m. site in the Marsta industrial area off the future Stockholm-Arlanda motorway. A works employing 150-175 people may manufacture chemical products—possibly proprietary articles or paints. The U.S. company will decide this summer whether or not to proceed with construction.

S. African Duty Sought on Perchloroethylene

African Explosives and Chemical Industries Ltd. have made representations to the South African Board of Trade and Industries for an increase in the duty on perchloroethylene from duty-free to 30% *ad valorem*.

Refinery Contracts Give M. W. Kellogg Busy Year

Progress of oil refinery contracts recently undertaken by the M. W. Kellogg Co., U.S., is briefly reviewed in the annual report of the parent concern. Pullman Inc. Kellogg engineers played a major role in the establishment of a 100,000 bbl./day refinery in Western Germany and accepted an additional oil refinery assignment in Germany to be completed in 1961 in the Ruhr. A 50,000 bbl./day refinery was completed and turned over to Mobil Oil Company de Venezuela by Kellogg. An earlier Kellogg built refinery in Chile was modernised and expanded to double the entire

refining capacity of Chile in 1960. Contracts were received in 1960 to build a complete refinery in Turkey and another in Pakistan.

In addition, Kellogg has received from the American Oil Co., a subsidiary of Standard Oil Co. (Indiana), a contract to design a 150,000 bbl./day crude oil unit, the largest in the world, and a 50,000 bbl. Orthoflow fluid catalytic cracker.

Work Starts on Big Soviet Natural Gas Pipeline

Construction has started on the world's largest natural gas pipeline, which will link the rich Gazli deposits in Uzbekistan with the industrial areas of the Urals. The deposits are estimated to contain some 17.5 million million cu. ft. of commercial gas; with other recently discovered deposits they are sited in the Bukhara-Kiva lowlands, where there are still uncalculable untapped resources.

Enough gas will be piped along the 2,750 miles of underground pipeline each year to meet all the industrial needs of the Urals industrial centres. The first 125 miles will be completed this year.

Tokio to Enlarge Carbon Black Plant

Tokai Electrode Co. are to enlarge their carbon black plant by 5,000 tonnes a year by means of a tie-up with the U.S. company, Cabot Co. This will give a total capacity of 9,600 tonnes.

U.S. Cellulose Film Sales Record for 1960

Sales of cellulose film in the U.S. reached a new record of 439 million lb. in 1960 in spite of increasing competition from other transparent packaging materials. The combination of cellulose film with other materials, such as polythene, through lamination and extrusion coating accounted for much of the 1960 growth.

Rumania Increases Chemical Export Quotas

Rumanian export quotas have been expanded considerably for this year for chemical products. Thus, the quota for carbide exports is treble former levels as is that for carbon black, while twice as much sodium products may be exported. Foreign trade quotas for benzole, toluol, synthetic rubber, detergents, phenol, acetone and plastics are introduced for the first time.

Expansion of Petroleum Refineries in Italy

A special Commission at the Ministry of Industry in Rome has given its approval of the construction of new petroleum refineries by the following companies: Sorap (Edison Group), 3 million tons a year in Northern Italy; Anic (ENI Group), 2 million tons a year, in the Valley of the Po; Mediterranean Petroli, 1 million tons a year, in Sardinia; Clasa, 1 million tons a year, near Civitavecchia.

The Commission has also decided to authorise the expansion of the capacity

of the following existing plants: Conдор Refinery at Rho (Shell) to about 4 million tonnes a year; Inpet Refinery at La Spezia, to about 4 million tonnes a year; Garrone Refinery, to about 4 million tonnes; Purfina, Rome, from 600,000 to 1,500,000 tonnes; Purfina, Genoa, from 450,000 to 570,000 tonnes; DICA, transfer from Avenza to Civitavecchia and, at the same time, increase of the capacity to 3 million tonnes a year; Italia Refinery at Cremona (now purchased by AMOCO of Standard Oil Calif. Group), to 3 million tons; Icip, Mantua, to 2 million tonnes.

The above figures do not include the so-called 'legal-reserve' capacity of 30%, which Italian refineries must have.

It is estimated that the new authorisations will increase the aggregate capacity of Italian refineries to about 20 million tons a year, excluding the 30% reserve.

S.A. to Make Cyclohexane at Clarkson, Ont.

British American Oil are to install Canada's first facilities for cyclohexane at their Clarkson, Ont. refinery to produce the material for sale to Du Pont of Canada for processing into nylon at Maitland, Ont. Construction of the cyclohexane plant will start early in 1962 and should be completed by the autumn of that year. Ultimate capacity will total 15 million gall./year.

Swedish Firm to Raise P.V.C. Output

Stockholms Superfosfat Fabriks AB, Stockholm, are to increase their output of p.v.c. by 55% to 25,000 tons by the end of 1962. Bertildi AB, Stockholm, have started making foamed p.v.c. under licence from Kléber-Colombes, Paris, at a works in Falkenberg.

Canadian Sulphur Capacities May Top 1.5 M. Tons in 1961

Production of elemental sulphur in Canada increased from 145,656 tons in 1959 to 254,729 tons in 1960. Production of sulphur in all forms last year totalled 837,000 tons and placed Canada fourth among the free world's producers. Completion, at the end of 1961 of plants now

under construction will provide West Canada with capacities for more than 1.5 million tons. Biggest capacity in 1960 was held by British American Oil at Pincher Creek, Alberta, with 264,000 tons; of plants now under construction, Shell Oil Co. of Canada will have a 385,000 tons/year plant at Waterton Park, Alberta, while Jefferson Lake Petrochemicals of Canada, will have a 332,500 tons/year unit at East Calgary.

Based on known estimates of natural gas reserves, the Canadian potential for sulphur recovery is between 150 and 300 million tons.

Kobe Firm Has New Yttrium Process

Santoku Metals Industry, Kobe, have announced a new method of obtaining the rare earth, yttrium in a very pure state. The essence of the process is the passage of yttrium oxide through an ion exchange membrane, treatment with fluorine, and distillation to yield sponge yttrium. Additions of yttrium to chrome steel, vanadium and other hard metals, greatly improves malleability.

New Persian Co. for Gas Utilisation

The State-owned National Iranian Oil Co., together with Sofregaz and Sopedrol, French and Swiss concerns respectively, have set up a subsidiary company, Sharikat Sahami Masraf Gas (S.S.M.G.), as a gas utilisation company.

Managing Agency Agreement for Chemicals in Uganda

A managing agency agreement has been signed by Torora Industrial Chemicals and Fertilisers Ltd., with African Explosives and Chemical Industries (East Africa) Ltd., a part of the I.C.I. Group, to allow for collaboration with the Uganda Development Corporation Ltd. in future chemical developments initiated in Uganda.

Other partners in the Torora fertiliser factory—which will cost some £400,000 and is expected to start production in 1962—are Ventures Ltd. of Canada and the International and Fertiliser Corporation, U.S.

Du Pont Plan Pilot Production of New H.T. Polyamide Fibre

A PILOT plant for the production of a new high temperature resistant polyamide fibre, HT-1, will be constructed at Richmond, Virginia, U.S., by E.I. du Pont de Nemours and Co. The fibre is stated to show great promise in industrial uses including electrical insulation, filtration of hot gases, special-duty beltings and reinforcement of high-temperature hose. Its application in various military uses is also being explored.

It is expected that the new fibre will not be available for sale outside the U.S. until the pilot plant is ready for operation. Construction is already under way and the pilot unit is scheduled to be completed late in 1962. It will be built

in an area on the Richmond site which one housed a part of the company's rayon plant.

At present Du Pont's Richmond plants make various products including high tenacity rayon and nylon for tyre cord and other industrial applications, Teflon TFE-fluoro-carbon fibre, and packaging films.

The new HT-1 fibre is a product of more than 12 years' research originating in Du Pont's research laboratories in Wilmington. The development work on HT-1 has been carried forward at the company's Bengler laboratory located at Waynesboro, Virginia.

Bookshelf

New Edition of Aerosols Book Reflects Growth of Industry

PRESSURIZED PACKAGING (AEROSOLS) 2ND EDITION. By *A. Herzka* and *J. Pickthall*. Butterworths, London, 1961. Pp. xii + 509, 70s.

The fact that a second edition of this book is called for within little more than two years of its original publication is excellent confirmation of its main theme that the aerosol industry is growing very rapidly. Every aspect of the industry from its history, through propellants, dispensers, filling and laboratory evaluation is carefully described. The authors have considerably altered the first edition, correcting errors, enlarging the sections on compressed gases and their applications and adding a new section on legal considerations, but they have not attempted to rewrite their work. The new edition should be welcomed by everybody concerned with the industry as a convenient source of information.

The half of the book that describes formulations will have a wider appeal. Chemists, not in the trade, will be interested to learn what goes into typical paint removers, nail polish removers and dog repellents. Some will not know that 'New Car Odour' can be had in aerosol form, and also an itch-relief spray. Nobody yet appears to have restored the balance of power by providing the school boy with itching powder in an aerosol pack.

► Plenary Lectures

XVIII INTERNATIONAL CONGRESS OF PURE AND APPLIED CHEMISTRY, PLENARY LECTURES AND SECTION LECTURES, VOL. I, INORGANIC CHEMISTRY. Butterworths, London, 1960. Pp. 341, 63s.

This book contains a record of the lectures given to the inorganic section of the congress in September 1959, a bare majority of which were in English. The lengths of the printed articles vary considerably, no doubt because the authors were allowed to extend their material and add references. The references are useful but it is doubtful if the extensions were worth the delay which they must have caused. Some authors have evidently not felt it necessary to change the form as the first contribution starts "Herr Präsident, meine Damen und Herren!"

All the lectures are by established authorities and are well worth reading. About half the chapters deal with metallo-organic chemistry, the rest with the actinides, hypofluorites, pure metals, non-aqueous solvents, equilibria in gases, semiconductors, transition metal oxides

and documentation. Anyone wishing to review current interests in inorganic chemistry could well start by reading these interesting lectures. The only field on which he will lack information is that of metal complexes in solution which have recently received much attention at other discussion meetings.

The general production of the book is good, but the paper is far too shiny for comfort.

► Organic Synthesis

THE OPERATIONS OF ORGANIC SYNTHESIS. 2ND EDITION. By *J. Lenoir*. Les Presses Documentaires, Paris, 1960. Pp. 354, NF.35.

It is common in France to find a course of instruction published in book form more or less as delivered, which at least saves the student the trouble of taking notes, and may make attendance at the lectures themselves superfluous. This book is just such a series of lecture notes directed to those students attending the Centre for the Instruction of Technical Operatives, and specialising in industrial organic synthesis. M. Lenoir gives a rather sketchy account of the main operations involved in the production of intermediates for the dyestuffs, plastics and similar industries, without going into great technical detail. The chemistry of the operations is likewise given a cursory treatment, some basic organic chemistry having been covered in an earlier course. This book does not seem to have any utility here, in that courses in the U.K. are conceived on quite different lines.

► Thermodynamics

ELEMENTARY CHEMICAL THERMODYNAMICS. By *G. Hargreaves*. Butterworths, London, 1961. Pp. viii + 120. Paper cover. 10s 6d.

This text is intended as an introduction to elementary thermodynamics—up to the effect of temperature upon chemical equilibria.

It is a most unfortunate, not to say dangerous, text to put in any student's hands. At least those who believe what they see in print will be seriously misinformed by two basic definitions: "A reversible process is one which is carried out so that a property of the system never differs by more than an infinitesimal quantity from one instant to another". (p. 9). "Entropy is the capacity for spontaneous change in a system". (p. 25).

It is a serious dis-service for such a text to appear from a reputable publisher. It contains nothing that is not far better done in a great number of elementary physical chemistry texts.

► Heat Bibliography

HEAT BIBLIOGRAPHY 1959. Edited by *D. E. Sexton*. H.M.S.O. Edinburgh, 1961. Pp. vi + 404, 20s.

This is the sixth volume of a heat bibliography compiled by members of the staff of the National Engineering Laboratory. It is essentially a list of titles of journal articles arranged under subject headings. The best way to describe it to a chemist is to state that it is a 'Current Chemical Papers' for the heat engineer, with the difference that there are slightly more categories of classification and the delay in publication is 18 instead of two or less months on an average. The delay enables the compilers to list abstract references for many of the papers as well as the original source. The value of a work such as this depends largely on the efficiency of the cross-referencing. As far as titles go it appears to be good in this case. Only prolonged use can show whether the categories adequately cover the contents of papers as well as the titles.

► Protein Analysis

ANALYTICAL METHODS OF PROTEIN CHEMISTRY. Vol. 1. THE SEPARATION AND ISOLATION OF PROTEINS. Edited by *P. Alexander* and *R. J. Block*. Pergamon, London, 1960. Pp. 242.

Tremendous strides have been made during the past 15 to 20 years in methods available for the basic study of protein structure. To a large extent this has been as a result of new methods elaborated for the study of the problem, particularly methods of analysis and isolation of individual proteins. This series is concerned with these advances in our knowledge and this first volume is specifically concerned with analysis and isolation of the proteins.

The authors have surveyed the existing field and have produced a working manual based on the practical experience of the contributors. In general, techniques are described in full detail so that the worker need not refer to any original literature on the subject and in most cases modifications of the technique are mentioned in some critical fashion. In a book of the nature, a short discussion of the theoretical principles underlying the technique is invariably called for and the authors have paid some attention to this point.

It is essentially a book for the research worker in proteins, but a very liberal cross section of analysts might gain profit from its reading, since many of the methods described could have application in other analytical fields.

Bookshelf

Second Edition of Well-known Texts of Excellent Value

PHYSICAL CHEMISTRY, 2ND EDITION. By *E. A. Maelwyn-Hughes*. Pergamon Press, Oxford. Pp. viii + 1333, 84s.

The second edition of this massive text book differs little from the first. The remarks made by original reviewers still apply, more especially because the treatment of well-established theory was always its strongest point. The treatment of recent experimental developments was never so satisfactory. The absence of a complete theoretical framework on which to set out gas kinetics makes the presentation extremely difficult even for a specialist in the field. This book relies too much on the classic works of Hinshelwood and quotes evidence that has been known to be unreliable for 20 years. Recent work on nitrogen pentoxide has not been properly digested. Many of the quoted rate constants have been superseded by better determinations. However, as the other reviewers remarked when the first edition appeared, one should hesitate to criticise the presentation of ones own speciality when one has not tried to write a treatise of the whole subject.

The book is excellent value and is particularly good for reference purposes. The presentation would better suit more studies if the mass of theoretical derivation were abbreviated and leavened with more descriptions of experimental setups.

► Catalysis in U.S.S.R.

SOVIET RESEARCH IN CATALYSIS—1956, PARTS I TO IV. English Translation arranged by *T. J. Gray*. Consultants Bureau Enterprises Inc., New York, 1959. Pp. 805. \$120.

This work consists of 148 original papers which appeared in the 1956 issues of the Consultants Bureau English Translations of five Russian journals. The papers have been classified by T. J. Gray into the following groups: Vol. I, 'Theoretical and sundry associated effects'; Vol. IIa and IIb, 'General papers'; Vol. III, 'Reduction, oxidation, and Fischer-Tropsch'; Vol. IV, 'Hydrogenation and cracking'. While some workers in the field of catalysis may find it convenient to have these translations collected together and classified, the fact that the papers are about five years old and have appeared at least twice before greatly detract from their usefulness.

► Gas Sampling

GAS SAMPLING AND CHEMICAL ANALYSIS IN COMBUSTION PROCESSES. By *G. Tine*. Pergamon Press, Pp. xvi + 94, 42s.

This book is the result of a need felt

by the Combustion and Propulsion panel of A.G.A.R.D. for a review of current practice. The author was despatched round 30 laboratory in Europe and U.S. to see how things are done. He is properly grateful for a pleasant trip, which to judge from internal evidence occurred some time ago. If the literature survey had been brought up to date this would not have been a serious deficiency. In fact the bulk of the references end in 1958; a few to 1959 appear to have been added as an afterthought. This is deplorable in a report on a very fast changing subject; this rapid rate of obsolescence is common to most non-fundamental aspects of technology. The book is expensive and there can be few readers who will find it sufficiently up to date to be useful.

► Separation Processes

SEPARATION PROCESSES IN PRACTICE. Edited by *R. F. Chapman*. Chapman and Hall, London; Reinhold, New York; 1961. Pp. vi + 209, 40s.

Unlike most symposia the one of which this book is a record was designed to instruct young chemical engineers rather than to provide a forum for discussion. Seven papers of approximately equal length cover 'Fundamentals of mass transfer', 'Fundamentals of design of liquid extraction processes', 'Ion exchange', 'Continuous crystallisers', 'Electric membrane processes', 'Separation by solvent extraction', and 'Tray types in fractionation columns'. Approximately the 'Fundamental' papers were written by university teachers; the remainder come from industry. Some brief discussions are recorded of the type that suggest that reprints were not available. The individual authors have made a real effort to instruct their audience and to answer the questions that are likely to occur to men concerned with application of the processes.

The price is reasonable for an American book of this type.

► Organic Nitrogen

INDUSTRIAL ORGANIC NITROGEN COMPOUNDS. By *M. J. Astle*. Chapman and Hall, London; Reinhold, New York. Pp. vii + 392, 112s.

The author of this book seems to have intended to write a work along the lines of the second edition of Sidgewick's 'Organic chemistry of nitrogen'. He intended to pay proper attention to methods of synthesis used in industry, while approaching the subject from a theoretical standpoint. This would hardly be the sort of book suggested by the title but it would have been a worthwhile task

to attempt. The author does not seem equipped for the job. On page 1 he muddles pKa and pK_b for ammonia and then proceeds to explain the erroneous figures he has tabulated. From the industrial point of view the book is too unbalanced for a general survey. One is left to guess at the important part played by nitrogen containing dyes in chemical industry. There is a profusion of references but the text often reads too much like a transcription of a card index.

► Phenothiazine Drugs

RECENT DATA ON THE PHARMACOLOGICAL AND CLINICAL PROPERTIES OF PHENOTHIAZINE DERIVATIVES (IN RUSSIAN). U.S.S.R. Academy of Medical Sciences, Moscow, 1958. Pp. 188.

This collection of papers on the physiological effect of drugs derived from the phenothiazine nucleus includes a short review of the synthetic methods employed in the preparation of these derivatives. Each Russian paper is followed by a brief summary in English.

International Organic Chemistry Symposium

An International Symposium of Organic Chemistry is to be held in Brussels on 11-14 June under the auspices of the International Union of Pure and Applied Chemistry on the occasion of the 75th anniversary of the foundation of the Société Chimique Belgique.

The proceedings of the meeting will be divided into five sections: structure of new natural products; methods used for the determination of chemical structure; syntheses and chemical reactions; bio-synthetic theories; and mode of action of naturally occurring compounds in biological processes.

Industrial Weed Control

The British Weed Control Council is to hold a one-day symposium in conjunction with the pesticides group of the Society of Chemical Industry on 30 June in the Assembly Hall of the Royal Commonwealth Society Northumberland Avenue, London W.C.2. It was felt that such a symposium is necessary in view of the growing need to establish the economic importance of controlling unwanted vegetation on industrial and civic sites and the importance of making the latest developments widely known.

Selling in Russia

A booklet, which is intended primarily for those attending the British Trade Fair in Moscow, and for those interested in expanding sales to the Soviet Union, has been issued by the Credit Insurance Association. Included in the booklet, called 'Selling in Russia' are articles on to what extent Anglo-Soviet trade should be treated as a business question as opposed to a political one; the present objectives in the Soviet economic policy; Soviet capacity to pay, and the Soviet Union as a credit risk.

● **Mr. W. Johnstone** has been appointed commercial director of Plant Protection Ltd., Yalding, Kent, an I.C.I. subsidiary, from 1 June. **Mr. J. A. Collier** will succeed him as agricultural sales manager for the whole of the I.C.I. northern region.

● **Mr. C. E. Wrangham, C.B.E.**, who is to retire as deputy chairman of Davy-Ashmore Ltd. and their subsidiaries and from the board of Simon-Carves Ltd., has been appointed chairman of Short Brothers and Harland Ltd., Northern Ireland. Mr. Wrangham became an executive director of the Power-Gas Corporation Ltd., now of the Davy-Ashmore Group, in 1957, and during the war was Principal Officer for Aircraft Equipment with the Ministry of Aircraft Production. A former member of the Monopolies Commission, he was before the war elected a director of C. Tennant Sons and Co. Ltd.

● **Mr. E. Jarman** has joined the Council of British Manufacturers of Petroleum Equipment as technical adviser, having relinquished the post of head of the Mechanical Engineering Division of the Kuwait Oil Co., which he has held since 1947, following 31 years' service in the oil industry including 17 years abroad.

● **Mr. T. A. Salvadori** has been appointed chairman of Mobil Chimica Italiana (Naples), an affiliate of Socony Mobil Oil Co. Inc., who are to build in Naples a 130,000 tonnes/year aromatics plant.

● **Mr. B. C. Lewis** has retired from the chairman ship of Ayrton, Saunders and Co., Ltd., manufacturing chemists, of Liverpool, after 38 years service with the company. He is succeeded by **Mr. Norman Marsh**.

● **Mr. R. Bennett, M.A., F.R.I.C.**, has been appointed consultant to the directors of Potter and Clarke Ltd. in connection with their development programme in the chemical field.

● **Mr. J. B. Wilkinson**, who has been appointed technical director of Williams (Hounslow) Ltd., Hounslow, Middlesex, has assumed full responsibility for the planning and co-ordination of all technical aspects of the company's activities. **Mr. A. G. Hopkins**, at present assistant



J. B. Wilkinson

works manager, has succeeded Mr. Wilkinson as works manager. These changes are timed to coincide with plans of the Williams Group for expansion and development.

PEOPLE in the news

● **Dr. S. J. Pirt**, principal scientific officer at the Microbiological Research Establishment, Porton, has been appointed to the London University readership in microbiology tenable at Queen Elizabeth College.

● **Mr. J. M. Ruskamp**, sales manager of the Zaandam, Holland, chemical company NV Zaanchemie, has been appointed to the board of the associated company NV Billiton Chemie, of The Hague. Billiton Chemie have taken over the commercial activities of Zaanchemie from 17 April, and the latter company will cease to operate commercially.

● **Mr. Ernest N. Pullom**, editor of *The Pharmaceutical Journal*, is leaving the Pharmaceutical Society on 31 May to take up a new appointment, that of pharmaceutical editor with Inter-continental Marketing Services Ltd. I.M.S. Ltd., is engaged in market research and advertising and has associate companies in France, Germany and Italy, and in the U.S. and Mexico. Before becoming editor of the Journal in 1957, he was for six years, editor of *The Export Review of the British Drug and Chemical Industries*.

● **Mr. J. P. M. van Waes**, director of chemical plant in the Dutch State coal-mining and carbon chemicals concern Staatsmijnen, of Limburg, has been appointed director in charge of new developments. His place as chemical director is taken by **Mr. H. A. Bunge**. **Mr. W. van der Zalm** has been appointed head of the Staatsmijnen nitrogen compounds plant.

● At the annual meeting of the Sulphur Institute held last week, seven members of the board of directors were re-elected until 1964; they are: **A. Castelletti** (Ente Zolfi Italiani, Rome); **J. Fouchier** (Soc. Nationale des Petroles D'Aquitaine, Paris); **C. T. Hill** (London); **Milton Lewis** (Hancock Chemical Co., Los Angeles); **Fredrik Qvale** (A/S Sulipjelma Gruber, Oslo); **A. de Torres Espinosa** (Compania Espanola de Minas de Rio Tinto S.A., Madrid) and **R. C. Wells** (Freeport Sulphur Co., New York). Two new board members elected were: **E. D. Loughney** (British American Oil Co. Ltd., Toronto) and **K. G. Ratjen**

(Sachtleben AG, Cologne). Re-elected to the executive committee were: **General A. Blanchard** (Soc. Nationale des Petroles D'Aquitaine); **T. Borresen** (Bolidens Gruvaktiebolag, Stockholm) **J. N. V. Duncan** (Rio Tinto Management services (U.K.) London); **C. O. Stephens** (Texas Gulf Sulphur Co., New York); **H. C. Webb** (Pan American Sulphur Co., Houston); **C. A. Wight** (Freeport Sulphur Co., New York); and **Dr. Russell Coleman** (Sulphur Institute, Washington). **Mr. Coleman** was re-elected president, **Dr. Rene Leclercq** was re-elected vice-president, Europe; and **Dr. Samuel L. Tisdale** and **Dr. M. S. Williams** were reappointed secretary and treasurer.

● **Mr. J. S. Boyd** (I.C.I.) and **Mr. F. N. Beaumont** (British Petroleum Co. Ltd.) are included in the Electrical Research Associations divisional committee No. 6, which will cover industrial applications.

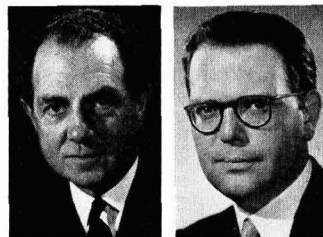

Willoughby R. Norman (left), who took over as chairman of Boots Pure Drug Co. Ltd., on 1 April, and **F. A. Cockfield**, the company's new managing director.

● **Dr. Helmut Brans**, of Dusseldorf, and **Herr Manfred O. von Haunschild**, of Hamburg, are to be nominated to replace **Dr. Ludwig Holbeck**, of Berlin, and **Dr. Clemens Plassmann**, of Dusseldorf, on the board of the West German chemical company Schering AG, Berlin. The two latter directors are not seeking re-election.

● **Mr. Russell C. Nelson**, director of sales of Du Pont de Nemours International S.A., Geneva, has been appointed to deputy managing director. He was assistant manager of the company's London office between 1956 and 1959.

● **Mr. A. Ormrod**, general sales manager of Walker Chemical Co. Ltd., Bolton, has been appointed a director of the company, which is a subsidiary of Walker and Martin Ltd.

● The Melchett Medal given by the Institute of Fuel has been awarded to **H. C. Hottel**, Professor of Chemical Engineering at the Massachusetts Institute of Technology in recognition of his contributions to the scientific understanding of combustion.

● On 21 June Glasgow University will confer hon. LL.D. degrees on **T. F. Macrae**, research director of Glaxo
(Continued on page 824)

Commercial News

Boots Pure Drug

Group profit of Boots Pure Drug Co. Ltd. for the year ended 31 March, before tax, was £4,562,790 (£3,734,693) but after charging depreciation and interest on loan stock, was £8,826,093 (£7,560,697). Group net profit was £4,263,303 (£3,826,004), an increase of 11%, while net profit of the parent company was £3,396,660 (£3,148,027). Dividends on ordinary take £1,881,600 (£1,646,400). Depreciation took £1,760,065 (£1,592,951) and the amount of the staff profit earning bonus charged in arriving at profits was £819,911 (£702,360).

Burt, Boulton

The directors of Burt, Boulton and Hayward Ltd. have written to shareholders stating that when the formal document containing the offer of Horlicks Ltd. (see 'Commercial News,' last week) has been issued they will then give detailed reasons why they are unable to recommend acceptance. B.B.H. have already stated that they can see no commercial advantage in the proposal.

Turner and Newall

The offer made on behalf of Turner and Newall Ltd. to acquire for cash the 10% free-of-tax cumulative 2s preference shares in British Industrial Plastics Ltd. has been accepted in respect of more than 90% of such shares and has now become unconditional.

Bydand Distillers

Group trading profit of Bydand Distillers and Chemicals Ltd. for the year ended 31 March was £181,159 (£157,955). Tax took £81,961 (£68,328) and net profit was £78,833 (£74,805). Final dividend of 12½%, making 20% (against an equivalent of 16½%) is announced.

Fisons

Interim dividend of Fisons Ltd. is being maintained at 4%.

Hilger and Watts

Hilger and Watts Ltd., makers of scientific instruments, have announced that Wray (Optical Works) Ltd. are now associated with them. Mr. A. W. Smith is continuing as managing director of Wray.

Bitumen and Oil Refineries

Bitumen and Oil Refineries (Australia) Ltd. have allotted 1.2 million ordinary 5s. share units for the purchase of 1 million £1 ordinary units of Petrochemical Holdings Ltd.

Bombrini

Net profit of Bombrini Parodi-Delfino, Rome, for 1960 was Lire 295,828,823. Sales of equipment and materials of a

- **Boot's Group 1960 Net Profit up 11%**
- **B.B.H. Not to Recommend Horlick's Offer**
- **Houdry Show Highest Earnings for 22 years**
- **Raffineries to Issue Conversion Loan**

non-military nature rose by 19% during the year, the rise being mainly accounted for by synthetic fibres (polyamide staple and yarn), and chemicals for industry and agriculture. During the year, B.P.D. increased their capital from Lire 4,000 million to Lire 5,000 million and issued Lire 4,000 million worth of bonds.

Elettro-Chemica Caffaro

Soc. Elettro-Chemica Caffaro, Milan, report a 1960 profit of Lire 138,429,947. Despite an increase in output of chemicals the whole of the 1960 production was sold.

von Heyden

The Munich, West Germany, chemical producers Chemische Fabrik von Heyden AG, are to recommend a 1960 dividend of 10%, plus 2% (same) on founders' shares and 5% (same) on priority shares. The company, whose founders' shares alone are worth DM8 million, is owned primarily by the German banking house Dresdner Bank AG, the Frankfurt-on-Main company Rütgerswerke AG and the U.S. chemical producers, Olin Mathieson Chemical Corp.

Hooker Chemical

Hooker Chemical Corporation for the first fiscal quarter ended 28 February reports net sales of \$34,686,300 (\$36,192,400) Net income for the quarter was \$2,618,800 (\$2,991,600), equivalent to 35 cents (40 cents) a share. The 12½% drop in earnings was attributed to several factors including increased costs for labour and certain raw materials. Also, the 4.2% reduced sales volume necessitated lower production rates on certain products with resultant increased unit cost.

Merck Sharp (Italia) Firm

Assets of Cipelli Industria Farmaceutica, pharmaceutical producers, Padua, have been acquired by Merck Sharp and Dohme (Italia) S.p.A. This acquisition will give Merck Sharp a base for expanded marketing of their corticosteroids, diuretics, anti-hypersensitives and anti-histamines. Cipelli's ethical products will be handled by the new organisation.

Houdry

Highest level of earnings in 22 years was reported to stockholders at the annual meeting of Houdry Process Corporation, U.S. Houdry and their subsidiaries, the largest of which is Catalytic Construction Co., earned \$3.11 (\$2.45) per share on consolidated net income after taxes of \$1,029,419 (\$810,210).

Catalytic's total sales in 1960 were \$40 mil. (\$34.5) which produced earnings after taxes of \$213,281 (\$133,320). Catalytic Construction Company of Canada Ltd. operated at a loss in 1960.

Mr. Burtis told the assembled stockholders that royalty income reached its highest level in many years, and that product sales reached the highest dollar volume ever achieved by the company. Another good year is anticipated in 1961.

Raffineries de Berre

At an extraordinary meeting of Compagnie des Produits Chimiques et Raffineries de Berre, the company controlling petrochemical and mineral oil interests of the French chemical concern Saint-Gobain, the company's board was given permission to issue a conversion loan totalling Fr.86,923,600. The loan bonds will be issued only to company shareholders, one bond worth Fr.100 to be drawn at will against two Berre shares, each of Fr.50 nominal value. The loan will carry an interest of 3½% as from 1 May. On 1 April, 1963, the bonds will be converted into shares, each Fr.100 bond being convertible into one share of Fr.50 nominal value. Unconverted bonds will carry 5% interest and be repayable at 115% within 15 years from 1 January, 1964. The issue of the loan represents a future increase in capital of 50% (see also 'Overseas News').

St.-Gobain

Cie. de Saint-Gobain, Paris, report a 1960 turnover of N.F.1,060 million (N.F.920 million). Despite increased depreciations of F.83 million (F.35 million), net profit rose from F.33.42 million to F.39.96 million. A dividend of 8 (7.33)% is to be paid on a capital of F.387,597,075 (F.372,804,125), should this be agreed to by the company's shareholders.

S.B.A.

Société Belge de l'Azote et des Produits Chimiques du Marly, Liège, Belgium, report for last year a net loss of B.Fr.32.6 million (B.Fr.17.9 million) after an annual gross trading profit of B.Fr.81.3 million (B.Fr.90 million). The company's total losses thus rose to B.Fr.74.2 million. The company last paid a dividend in 1956.

Soc. Larderello

Soc. Larderello, Lungarno Pacinotti 16, Pisa, report a net profit of Lire 939.8 million for 1959. Chemical output totalled 21,000 tonnes, an increase of 28% on 1959. During the year, the company started operating new plant for the production of borax and expanded capacity of their existing boric acid unit.

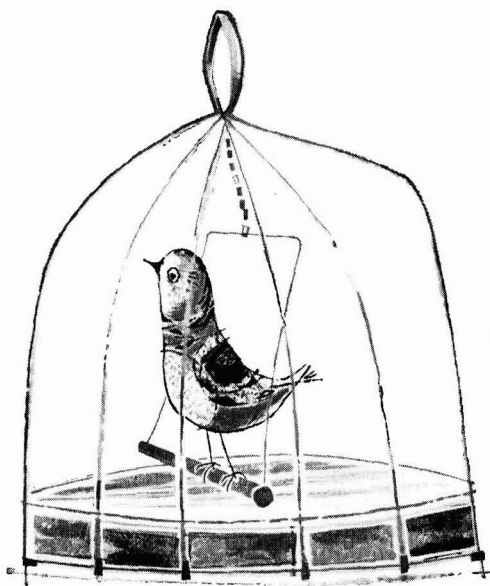

**IT'S A SMALL WORLD
AND MARCHON SURFACTANTS PLAY A BIG PART IN IT**

You don't need a little bird to tell you that. Ask any detergent manufacturer and he'll tell you that many of the best known detergents are formulated from Marchon surfactants.

SO₃ SULPHONATED DODECYL BENZENE

Now forms part of Marchon's range of dodecyl benzene sulphonates, and includes high purity sulphonic acids and their sodium salts with minimum inorganic content; especially suitable for liquid detergent formulations. Why not write for data, samples or advice?

Marchon

TRADE NOTES

Flame-retardant Compounds

Monsanto Chemicals Ltd., Monsanto House, Victoria Street, London S.W.1, have developed a series of organophosphorus compounds known as Phosgard which impart flame retardant properties to plastics, textiles and paper. A data sheet on the compounds is available.

Hardinge Thickener

The Hardinge Thickener, claimed to be capable of removing the maximum amount of liquid from a mixture of liquid and finely divided solids, is the subject of an illustrated brochure from International Combustion Products Ltd., 19 Woburn Place, London W.C.1. Construction of the thickener as well as its applications are described.

Heat Transfer Medium

Thermocal DF heat transfer medium, consisting essentially of ethylene glycol, is coloured with a distinctive pink dye for ease of identification and contains a novel system of corrosion inhibitors. It is miscible with water in all proportions and, because it depresses the freezing point of water, and also raises the boiling point, its aqueous solutions can be used as heat transfer media where water itself is unsuitable, for example as defrosting fluids and industrial coolants. Aqueous solutions of 'Thermocal' DF are suitable for use as heat transfer media in the temperature range—40° to 100°C.

These and other facts about Thermocal DF are contained in a 10-page booklet by Imperial Chemical Industries Ltd., Heavy Organic Chemicals Division, Billingham, Co. Durham.

Head Wrightson Services

A leaflet available from Head Wrightson Processes Ltd., 20/24 Old Street, London E.C.1, summarises the company's comprehensive service covering heating and cooling processes, water treatment and effluent treatment. A further leaflet gives details of the Series 1 cooling tower, designed for small industrial and air conditioning applications.

Emulsions and Adhesives

H. A. Smith Ltd., adhesives, resins and coatings, Braunston, nr. Rugby, have published an illustrated booklet describing their Tenaxatex range of products. These include p.v.a. emulsions and prepared adhesives, acrylate polymers and co-polymers, methacrylate co-polymers and styrene co-polymers.

Trimethylorthoformate

Trimethylorthoformate, now available for development evaluation from F. W. Berk and Co. Ltd., Berk House, 8 Baker Street, London W.1, substance closely resembles acetals in its properties. It has wide uses as an intermediate for organic syntheses, and is expected to be of particular interest to manufacturers of drugs and pharmaceuticals, perfumes, waxes and polishes, photographic materials, etc.

Organometallic Compound

A technical data sheet describing chemical and physical properties, sug-

gested uses and offering sample quantities of TBTO bis(tri-*n*-butyltin) oxide is available from Metal and Thermit International Corporation, New York 17, N.Y., U.S.A. A slightly yellow clear liquid that contains more than 95% active ingredient, TBTO represents a new class of organometallic chemical compounds that exhibit control of fungi, bacteria, algae, and marine organisms.

Unformulated TBTO is a water-insoluble liquid that has a tremendous affinity for cellulose. It is, therefore, especially useful as a wood preservative in marine environments, or for odour control of washed fabrics. Other suggested uses include: control of paper-mill slime; control of algae and fungi in industrial cooling systems; anti-fouling paints; textile treating; mildew control of plastic or paper surfaces.

Gallenkamp Review of Achema Exhibits

CURRENT copy of *News and Review*, the bi-annual publication of A. Gallenkamp and Co. Ltd., Technico House, Sun Street, London E.C.2, contains details in 42 pages of the company's exhibits at the Achema chemical plant exhibition to be held in Frankfurt from 9 to 17 June. This exhibition preview is printed in English, French and German.

Also included are details of new developments—Lloyd gas analysis apparatus, ballistic bomb calorimeter and Bjerkerd apparatus for determining hydrogen in steel.

New London H.Q. for Natural Rubber

Following re-organisation of natural rubber research and development units financed by the Malayan Rubber Fund Board, the London headquarters have been moved to 19 Buckingham Street, Adelphi, London W.C.2. Mr. E. Jago, O.B.E., the board's London representative moved on 6 May as did the Natural Rubber Bureau. The Natural Rubber Producers' Research Association was moved to the Adelphi address on 13 May and the staff of the former London Advisory Committee, now absorbed in the Natural Rubber Bureau, will move on 25 May.



TUESDAY 23 MAY
S.C.I.—London: 14, Belgrave Sq., S.W.1, 6.30 p.m. A.g.m. Polymers & Plastics.
Soe. Instrument Tech.—London: Mansion House, 26, Portland Place, W.1, 6 p.m. A.g.m.

WEDNESDAY 24 MAY
S.C.I.—London: 14, Belgrave Sq., S.W.1, 6.15 p.m. A.g.m. Food.

FRIDAY 26 MAY
S.C.I.—London: 14, Belgrave Sq., S.W.1. A.g.m. 'Heavy organic planning in the U.K. chemical industry'.

People in the News

(Continued from page 821)

Laboratories Ltd. and **J. W. McLeod**, former Professor of Bacteriology, Leeds University.

● **Mr. A. S. N. Roberts**, hitherto chief chemist of the Rochdale undertaking of the North Western Gas Board, has joined the chemical engineering staff of the technical division of Process Plant Contractors (Campbell) Ltd.

● **Mr. H. W. Vallender** has been appointed deputy director of the Association of British Chemical Manufacturers. He joined the Association in 1943 and since 1950 has been in charge of the commercial department.

● **Mr. J. Ecthells**, of B.T.R. Industries Ltd., was elected chairman for 1961-62 of the Association of British Ebonite Manufacturers.

● **Mr. Leslie Pate** has been appointed general sales manager of Q.V.F. Ltd., Stoke-on-Trent. **Mr. John Linnell** has been appointed home sales manager.

● **Mr. G. R. Hardstaff** has been appointed by the Pyrethrum Board of Kenya as U.K. public relations officer. He will work in conjunction with the African Pyrethrum Technical Information Centre Ltd., and with Press and Public Relations Ltd., consultants to the board.

● **Mr. C. H. Addison**, chief chemist of Peek Frean & Co. Ltd., London, S.E.16, is leaving at the end of this month to become quality controller at the Grimsby factory of Birds Eye Foods Ltd.

● **Dr. G. W. Cooke**, head of the Chemistry Department at Rothamsted Experimental Station, Harpenden, and vice-president of the Fertiliser Society since 1960, has been elected president to succeed **Dr. H. L. Richardson**, head of the I.C.I. Central Agricultural Council's Overseas Department, who has been seconded for two years to the Food Agricultural Organisation in Rome.

● **Mr. Robert S. First**, president of Robert S. First Inc., chemical consultants of New York and Brussels, has been nominated as chairman for 1961 of the American Chemical Society's Division of Chemical Marketing and Economics.

Tees-side Chemical Plants Use 132 M. Gall of Water

The chemical industries on Tees-side alone use 132 million gall. of water a week. This figure was quoted by Alderman C. W. Allison, chairman of the Tees Valley and Cleveland Water Board, when he recently opened inaugurated work on a new £2,367,487 Balderhead Reservoir. I.C.I. and Dorman Long have provided financial assistance for the project which will give a 4,000 million gall. reservoir. Further work is planned to raise the board's resources to more than 65 million gall. a day.

PRISTERENE

*Stearines that
flow like water!*

Pristerene is a registered trade mark



IN BEADS

*Stearines that
flow like water!*



STEARIC ACID BEADS, now in bulk supply! Beads by the billion . . . beads that *flow*. This big news from Price's means stearines with a new characteristic . . . they *behave*. Because they are free-running, they are easier to handle manually: easier still, they can be moved pneumatically. Bead stearines are cleaner—they do not dust, as powders do—and they keep better in store, with less likelihood of caking.

New, larger beading plant now enables Price's to offer their complete Pristerene range of high-quality stearic acid in bead form—in any commercial quantity and at no extra cost. Ask Price's about pneumatic handling—the modern way to deliver stearine from your warehouse to your plant.



PRICE'S (BROMBOROUGH) LTD

OLEOCHEMICALS IN THE SERVICE OF INDUSTRY

Bromborough Pool, Bebington, Wirral, Cheshire. Telephone: Rock Ferry 2020 Telex: 62408

NEW PATENTS

By permission of the Controller, H.M. Stationery Office, the following extracts are reproduced from the 'Official Journal (Patents)', which is available from the Patent Office (Sales Branch), 25 Southampton Buildings, Chancery Lane, London W.C.2, price 3s 6d including postage; annual subscription £8 2s.

Specifications filed in connection with the acceptances in the following list will be open to public inspection on the dates shown. Opposition to the grant of a patent on any of the applications listed may be lodged by filing patents form 12 at any time within the prescribed period.

ACCEPTANCES

Open to public inspection 14 June

- Purification of polymers contaminated by metal compounds. Shell Internationale Research Maatschappij N.V. **870 326**
 Fluorine compounds. Du Pont de Nemours & Co., E. I. **870 328**
 Linear polyester films having surfaces suitable for writing thereon. Kalle AG. **870 330**
 Polymerisation. Union Carbide Corp. **870 480, 870 481**
 Resin compositions which are self-extinguishing when cured. United States Rubber Co. **870 331**
 Chemical modification of rubbery copolymers. Esso Research & Engineering Co. **870 332**
 Carbon dioxide pressure reducing method and apparatus. Air Reduction Co. Inc. **870 333**
 Phenylalkylamine derivatives and a method for their preparation. Smith, Kline & French Laboratories. **870 541**
 Amino-trifluoro-toluene-disulphonyl compound and the production thereof. Olin Mathieson Chemical Corp. [Divided out of **870 575**]. **870 576**
 Sheet materials comprising coated polyethylene. Lowe Paper Co. [Divided out of **868 924**]. **870 224**

Open to public inspection 21 June

- Metal organic amino compounds. Castrol Ltd. **871 144**
 Production of phenothiazine derivatives. Etablissements Clin-Byla. [Addition to **816 582**]. **871 002**
 Methine dyes. Ilford Ltd. **870 753**
 Method for the preparation of polymers from aliphatic olefin hydrocarbons. Bergwerksgesellschaft Hibernia AG. **871 004**
 Complex metal compounds of monoazo-dyestuffs, derived from cyanuric halides, their manufacture and use. Ciba Ltd. **870 985**
 Cyanine bases and undissociated cyanine dyes containing an azaindenyl nucleus. Kodak Ltd. **871 113**
 Alkali metal silicate-containing mould-forming compositions. Diamond Alkali Co. **870 805**
 O-dialkyl-phosphoric and thiophosphoric acid esters. Montecatini. [Addition to **811 644**]. **871 069**
 Desulphurisation of gases. Office National Industriel de l'Azote. **871 076**
 Butyric acid amides substituted at the nitrogen atom and β -carbon atom. Farbwerke Hoechst AG. **871 252**
 Polymeric oxidation products of phenols. American-Marietta Co. **871 078**
 Aqueous emulsion copolymers and thickening procedures using them. Rohm & Haas Co. **870 994**
 Process for the manufacture of polyvinyl ester dispersions. Farbwerke Hoechst AG. **871 254**
 Foamed polymers. Union Carbide Corp. **870 940**
 Esters of perfluorochloroaliphatic carboxylic acids. Minnesota Mining & Manufacturing Co. **871 218**
 Tris(hydroxymethyl)-phosphine and process for making it. Farbwerke Hoechst AG. **871 190**
 Process for the production of N-trialkyl borazanes. Studiengesellschaft Kohle. **871 085**
 Process for the production of D.L.- α -azido-caprolactam and D.L.- α -amino-caprolactam. Geigy AG, J.R. **871 220**
 Grafted polymers. Imperial Chemical Industries Ltd., Burrows, H. G., Sweeney, T., and Todd, S. M. **871 192**

- Recovery of antibiotics by means of ion-exchange resins. Merck & Co. Inc. **871 221**
 Stabilisation of organic material normally subject to oxidative deterioration. Geigy AG, J. R. **871 196**
 Nonionic surfactant-iodine composition. General Aniline & Film Corp. **871 197**
 Converter system for liquefied gases. British Oxygen Co. Ltd. **870 942**
 Process for the manufacture of coloured derivatives of polyhydroxylated substances of high molecular weight. Ciba Ltd. **871 087**
 Process for making uranium hexafluoride. Hercules Powder Co. **871 061**
 Process for preparing alumina base chromium oxide catalyst. American Cyanamid Co. **870 761**
 Process for extracting acetylene from pyrolysis gases obtained by the thermal decomposition of hydrocarbons. Soc. Belge de l'Azote et des Produits Chimiques du Marly. **870 737**
 Process for the cooling of alkali metal hydroxide solutions. Columbia-Southern Chemical Corp. **871 224**
 Vulcanisation rubbery composition. Firestone Tire & Rubber Co. **870 947**
 Nitration of aromatic compounds. United States Rubber Co. **871 048**
 Anthraquinone dyestuffs. Imperial Chemical Industries Ltd. **870 948**
 Pyruvic acid derivatives. Imperial Chemical Industries Ltd. **871 198**
 3-Thiopyruvic acid derivatives. Imperial Chemical Industries Ltd. **871 199**
 Process of manufacture of ferrocene derivatives. Imperial Chemical Industries Ltd. **870 949**
 Borohydrides of heavy metal complexes. Farbenfabriken Bayer AG. **871 202**
 Process and apparatus for recovering ammonia. Soc. Metallurgique de Normandie. **871 207**
 Malonic ester amide. Soc. Italiana Brodotti Schering. **870 887**
 Substituted piperazinone. Lepetit S.p.A. **870 888**
 Alkylation processes. Institut Francais du Pétrole, des Carburants et Lubrifiants. **870 772**
 Aromatic glycols and polyester and alkyl resins derived therefrom. Nopco Chemical Co. **870 957**

- Carbon black manufacture. Columbian Carbon Co. **870 720**
 Light sensitive diazotype materials. General Aniline & Film Corp. **871 216**
 Benzoylhydrazines. Bristol-Myers Co. **871 217**
 Stabilisation of chlorinated hydrocarbons. Imperial Chemical Industries Ltd. **871 036**
 Borazoles and method of making same. United States Borax & Chemical Corp. **870 959**
 Preparation of acid addition salts of *n*-butylbiguanide. Chemie Grunenthal GmbH. **871 182**
 Electrothermic fluidised bed apparatus. Shawinigan Chemicals Ltd. **870 961**
 Production of films of alpha-olefin polymers. Montecatini. **871 183**
 Polyacrylamides and process of producing same. American Cyanamid Co. **870 711**
 Polyaldehydes and their production. Du Pont de Nemours & Co., E. I. **870 775**
 Catalytic conversion of carbon monoxide. Metallgesellschaft AG. **870 714**
 Method of making a reinforced synthetic resin composition. Esso Research & Engineering Co. **870 715**
 Organic compounds of boron. United States Borax & Chemical Corp. **871 185**
 Manufacture of useful forms of vitamin-B₁₂. Hoffmann-La Roche & Co. AG, F. **870 778**
 Gas purification. Foster Wheeler Ltd. **870 895**
 Dichloro-aminobenzoic acid and derivatives thereof and herbicidal compositions obtained therefrom. Amchem Products Inc. **871 232**
 Removal of hydrogen sulphide. North Western Gas Board, and Clayton Aniline Co. Ltd. **871 233**
 Preparation of oximes. Commercial Solvents Corp. **870 787**
 Substituted pyrrolidones and salts thereof and a process for the manufacture of same. Hoffmann-La Roche & Co. AG, F. **871 235**
 Production of basic aluminium salts of aliphatic carboxylic acids. Du Pont de Nemours & Co., E. I. **870 792**
 Filled cross-linked polyethylene. General Electric Co. **871 236**
 Process for alkyl and aralkyl biguanides. U.S. Vitamin & Pharmaceutical Corp. **871 237**
 Process for the production of 6-(2',6'-6'-trimethyl cyclohexenyl)-1'-4-methyl-hexa-3, 5-diene-1-yne. Farbenfabriken Bayer AG. **870 965**

Market Reports

ACTIVE DEMAND FOR BORACIC ACID

LONDON Business in chemicals during the past week has been satisfactory for the period, and most of the routine potash chemicals and soda products have moved steadily against contracts. Chlorate of soda products have moved steadily against contracts. Chlorate of soda and hyposulphite of soda have been in good request and elsewhere there has been an active demand for borax and boric acid, hydrogen peroxide, formaldehyde and arsenic. Copper sulphate is in steady call for export at the current price of £80 per ton, less 2% f.o.b. Liverpool.

There has been little of fresh interest to report in the market for agricultural chemicals, and in the coal tar products market there has been a good outlet for supplies of the naphthalenes and the pyridines.

MANCHESTER Prices of heavy chemicals on the Manchester market are steady to firm. A further advance of £2 has brought the current quotations of copper sulphate to £80 per ton less 2%

f.o.b. Liverpool. There has been little change of any consequence elsewhere. Contract commitments are being drawn against steadily by most home users and shipping business seems to have been well maintained. A fair weight of new buying has been reported. With a few exceptions the light and heavy coal-tar products are going steadily into consumption.

SCOTLAND Business during the past week has been quite brisk with a good movement of general chemicals in most sections of industry. Quantities have not shown much alteration but on the whole have been well maintained. Prices have for the most part been steady although there has been some alteration in those affecting metal derivatives.

In regard to agricultural chemicals, trading has been brisk, mostly against urgent requirements. The position of the export market is still one of improvement particularly in inquiries for the Commonwealth countries.

RE-REFINING OF USED MINERAL OILS. BLEACHING OF EDIBLE OILS AND FATS. BLEACHING OF TECHNICAL OILS, FATS AND WAXES. REFINING OF LUBRICATING OILS. FOUNDRY FULLERS' EARTH BONDING CLAYS. OIL-WELL DRILLING MUDS. INSECTICIDE CARRIER. CATALYST. CATALYST CARRIER. INDUSTRIAL FLOCCOR CLEANING COMPOUND. IN PHARMACEUTICALS. IN KEROSENE AND GASOLENE SWEETENING. FORMULATION OF WETTABLE PESTICIDE POWDERS. IN TAR AND BITUMEN EMULSIONS. FOR PELLETISED ANIMAL FEEDSTUFFS. CIVIL ENGINEERING APPLICATIONS. THICKENING AND PLASTICISING. SUSPENDING AGENT. BONDING AGENT. REGENERATION OF USED SOLVENTS. IN AGRIC

THE VERSATILITY

OF FULLERS' EARTH

The unique structure of the clay mineral Montmorillonite confers on the products manufactured from it by The Fullers' Earth Union many special properties of increasing industrial importance. Impurities and unwanted colour are adsorbed from oils, fats and similar substances, it can be used as a bonding material, in foundries, in drilling . . . the list is endless and growing. Technically the properties of various Fullers' Earth products cover absorption, adsorption, catalytic activity, ion exchange, bonding and thixotropy.

Our Research and Development Departments are continuously engaged in widening the field of applications for this versatile material. If you think there may be possibilities in your industry, we should be glad to discuss them with you.

Please write or telephone:

THE FULLERS' EARTH UNION LTD.
PATTESON COURT · NUTFIELD ROAD
REDHILL · SURREY · Tel: Redhill 3521



A MEMBER OF THE LAPORTE GROUP

PLANT AND MACHINERY FOR SALE: continued

Three Lead lined STEEL TANKS, 14,000 galls., 9 ft. diam. by 35 ft. long.

Three Lead lined STEEL TANKS, 9,500 galls., 13 ft. 6 in. diam. by 10 ft. high.

Two NICKEL SILVER TANKS, 6,750 galls., 8 ft. diam. by 23 ft. 3 in.

Brand New COCHRAN Vertical and ECONOMIC Self-contained STEAM BOILERS in stock, also all sizes reconditioned and guaranteed. List on request.

STAINLESS STEEL TANKS, PANS, CONDENSERS, PLATES, VALVES AND COCKS. Very wide selection.

FRED WATKINS (ENGINEERING) LTD.,
COLEFORD, GLOS.

Phone: Coleford 2271/2.

SITUATIONS VACANT: continued

COALITE AND CHEMICAL PRODUCTS LIMITED have vacancies in their laboratories at Bolsover for chemists and technologists who would be interested in work related to the low temperature carbonisation of coal. The work is both interesting and rewarding. For those possessing outstanding capabilities, opportunities will arise for employment in, or transfer to research work and to production supervision. Vacancies exist in the following laboratories:—

CENTRAL REFINERY Analytical and Production Control Laboratories

CARBONISATION WORKS Production Control Laboratory

RESEARCH DEPARTMENT Organic Chemistry, Carbonisation and Fuel Laboratories

Applications stating age, experience, qualifications and salary required to:—

Assistant Managing Director,
Coalite and Chemical Products Limited,
P.O. Box No. 21
Chesterfield.

In addition to filling these particular vacancies, applications are invited from young men aged 17/20 years, interested in science, with a view to training in the carbonisation and coal chemicals industry.

ANALYST required to take charge of Analytical Department. Should have experience of general chemical analysis as well as modern instrumental methods including absorption and emission spectrography and gas chromatography. Starting salary according to age and qualifications. Five-day week; pension scheme. Write for application form to **Sondes Place Research Institute, Dorking, Surrey.**

CLASSIFIED ADVERTISEMENTS

Continued from page 832

WANTED

WANTED.—Scrap Graphite either new or used. Current price offered approximately £10/12 ex works in minimum 1 ton lots. Please submit samples. **Box 3746, Chemical Age.**

WORK WANTED & OFFERED

CRUSHING, GRINDING, MIXING and DRYING for the trade THE CRACK PULVERISING MILLS LTD.

Plantation House,
Mincing Lane,
London, E.C.2.

PULVERISING of every description of chemical and other materials. Collections, storage, deliveries. **THOMAS HILL-JONES, LIMITED, INVICTA WORKS, BOW COMMON LANE, LONDON, E.3. (TELEPHONE: EAST 3285.)**

Fire Prevention Standard Recommendations

THIS SYSTEM OF STANDARD RECOMMENDATIONS for fire prevention was devised by the Kent County Brigade.

'..... streamlines paper work in the preparation of fire prevention reports'. **Municipal Journal**

'..... intelligent standardization of form and wording makes for more efficient work all round'

T.L.S.

8s. 6d. [postage paid]

Published by

ERNEST BENN LIMITED

Bouverie House . Fleet Street . London . EC4

SAFETY FIRST

THE "OLDBURY" PATENT
CARBOY DISCHARGER

will empty and elevate up to 50 feet the contents of any carboy, bottle or vessel, and complies with all the conditions of the Factory Act of 1937

KESTNER'S

5, Grosvenor Gardens, Westminster, London, S.W.1

The quickest way

to obtain the services of a chemical engineer, chemist, laboratory assistant and other fully qualified personnel

is through a classified advertisement in *Chemical Age*

Full details will be found on page 831

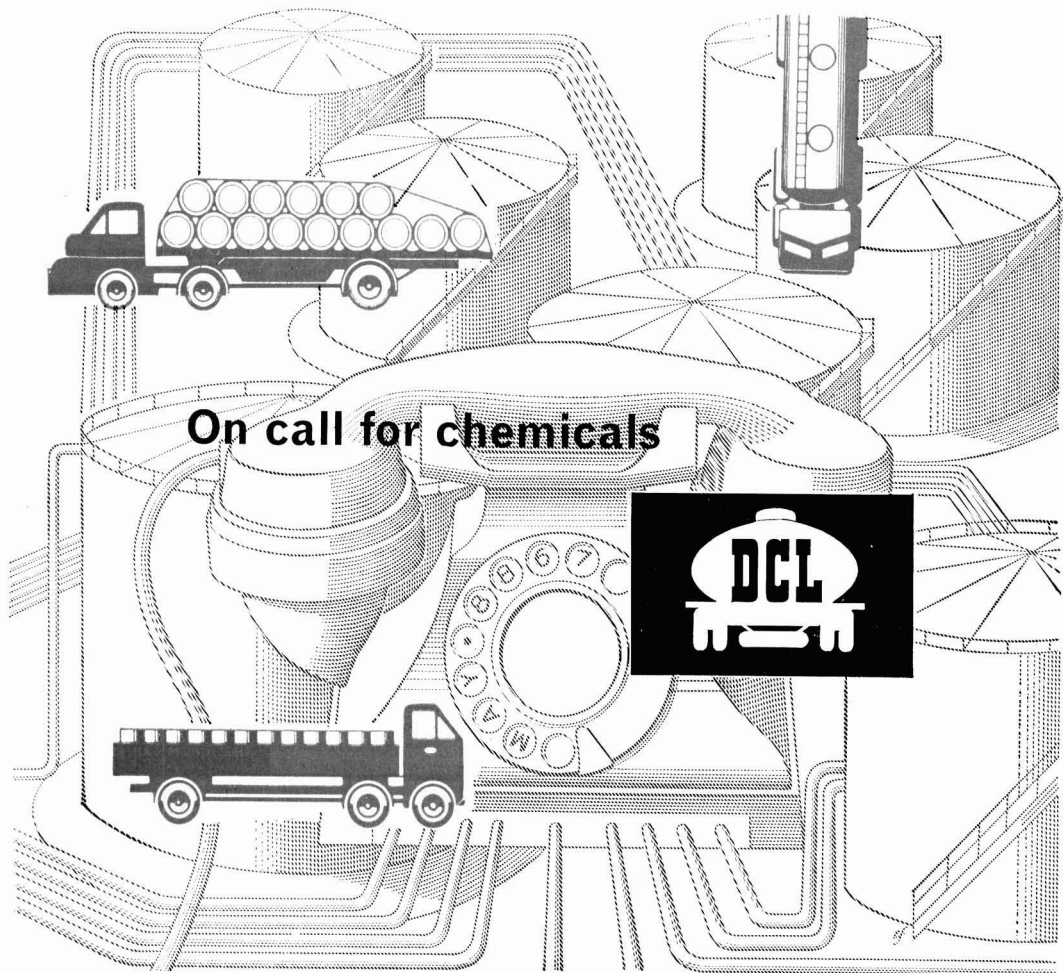

On call for chemicals



The service organisation behind the 200,000 ton annual production of DCL Bisol solvents, intermediates and plasticisers is as modern and efficient as the factories producing them. Delivery from a nation-wide network of supply depots is fast and dependable, and the well equipped Technical Services Laboratories are always ready to help customers with their manufacturing problems.

- ACETONE
- ACETATE ESTERS
- DIACETONE ALCOHOL
- M.E.K.
- BUTANOL
- LOBOSOLS
- PHTHALATES
- ADIPATES



THE DISTILLERS COMPANY LIMITED · CHEMICAL DIVISION

Bisol Sales Office, Devonshire House, Piccadilly, London, W.1.

Telephone: MAYfair 8867

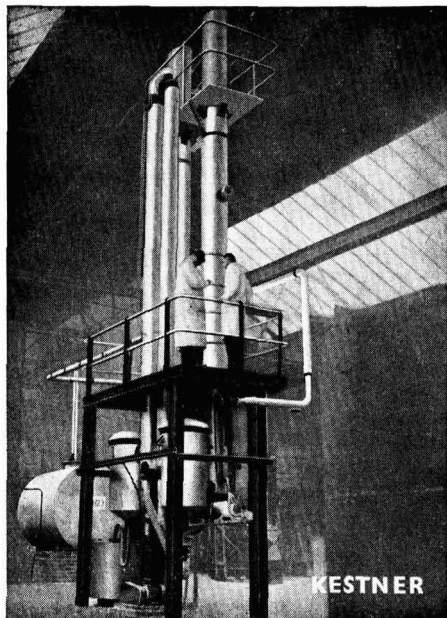

EVAPORATING PLANT

Kestners have originated and developed many types of evaporating plant, including :

Climbing and Falling Film ; Multiple Effect ; High Vacuum Multi-Circulation ; Vapour Recompression ; Acid Evaporators with no metallic contact and Keebon tubes. Evaporators heated by high temperature fluid heat transmission systems.

The Kestner Patent Coolcentrator

An entirely new system for the continuous concentration or distillation of liquids at low temperatures without the use of steam.

There is a Kestner Evaporator to suit all problems

Concentration of Acid and Corrosive Liquors ; Caustic Soda : Fruit Juices ; Glue and Gelatine ; Pharmaceuticals ; Milk ; Spinning Bath Liquors ; Vegetable and Wood Extracts and chemical solutions generally.

Kestner Patent Double-Effect Climbing and Falling Film Evaporator for Lithium Compounds (By courtesy of Associated Lead Manufacturers Ltd.)

KESTNER EVAPORATOR & ENGINEERING CO. LTD.

5 GROSVENOR GARDENS LONDON S.W.1

Kestner
THE CHEMICAL ENGINEERS

TURBO-
AGITATORS

TURBO-
EMULSIFIERS

TURBO-
REACTORS

TURBO-
IMPASTERS

TURBO-
CLEAVERS

TURBO-
DISPERSERS

MIXERS OF
ALL TYPES

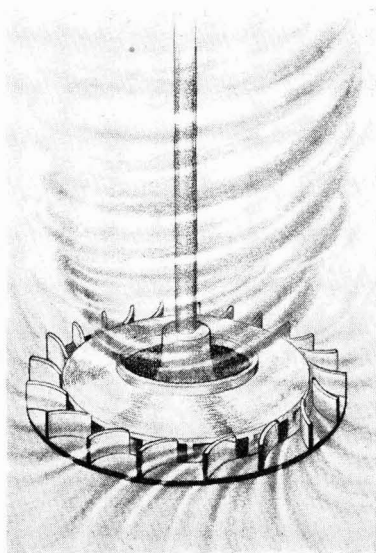

**MIX
WITH**

MORITZ
CHEMICAL ENGINEERING CO. LTD.
204, Earls Court Road, London, S.W.5

Phone: FRO. 3174 & 3175 Grams: MORICHEM LONDON

LEAFLETS ON REQUEST

GLASSBLOWING



Prompt delivery our speciality
OFFICIAL DISTRIBUTORS OF QUICKFIT
and QUARTZ GLASSWARE

We welcome your enquiries
Micro and Semi Micro
apparatus available from stock

**T. W. MCCARTHY
& SON, LTD**

Complete Laboratory Furnishers

30a Clifton Street, Cardiff

Telephone: Cardiff 26251



CARBOY HAMPERS

**LEIGH
& SONS
METAL
WORKS**
Orlando LTD.
Sc., BOLTON

CARBOYS · PACKED CARBOYS
CARBOY FILTERS AND BARROWS
SAFETY CRATES TOP PROTECTORS

CLASSIFIED ADVERTISEMENTS

CLASSIFIED RATES: All sections 5d. per word. Minimum 8/- . Three or more insertions 4d. per word. Box Number 2/- extra.

SEMI-DISPLAY: 30/- per inch. Three or more insertions 25/- per inch.

SITUATIONS VACANT



BRITISH HYDROCARBON CHEMICALS LIMITED

(Manufacturers of Petroleum Chemicals)

require a

PUBLIC RELATIONS OFFICER

at its London Head Office

Applicants should be in age group 35-45, preferably with a degree (B.Sc. would be an advantage), and have some journalistic experience, if possible in chemical subjects. They must be accustomed to dealing with a wide variety of people.

The duties will include press liaison, the preparation of press releases, arranging visits and escorting

visitors to factories, writing technical articles, preparation of prestige advertisements and preparation and production of the Company's newspaper and brochures.

Commencing salary according to age and experience and there is an excellent non-contributory pension scheme.

Please apply with full particulars to:

**Personnel Department, British Hydrocarbon Chemicals Limited,
Devonshire House, Mayfair Place, London, W.1.**

ANALYTICAL ASSISTANT

Young man with at least G.C.E. 'A' level chemistry or O.N.C. is required for the analytical department of the control laboratory of a rapidly expanding chemical company in N.W. London. Starting salary will be approximately £700 per annum depending on qualifications and experience. Excellent prospects for ambitious young man capable of improving his technical knowledge. Applications giving full details of age, qualifications and present salary should be sent in confidence to Personnel Manager, **Box 3753, Chemical Age.**

PATENTS & TRADE MARKS

The Proprietors of British Patents Nos. 768,941 for "SEPARATION OF PHENOLS FROM AROMATIC ISO-PROPYL COMPOUNDS BY DISTILLATION," and 770,650 for "IMPROVED PROCESS FOR THE SEPARATION OF AROMATIC ISOPROPYL COMPOUNDS FROM PHENOLS," desire to enter into negotiations with a firm or firms for the sale of the patents or for the grant of licences thereunder. Further particulars may be obtained from Marks & Clerk, 57 & 58 Lincoln's Inn Fields, London, W.C.2.

PATENTS & TRADE MARKS: continued

The Proprietors of British Patent No. 769,415 for "THERMO-SETTING AMINOPLAST COMPOSITIONS," desire to enter into negotiations with a firm or firms for the sale of the patent or for the grant of licences thereunder. Further particulars may be obtained from Marks & Clerk, 57 & 58 Lincoln's Inn Fields, London, W.C.2.

BOX NUMBERS: Reply c/o "Chemical Age"

• Bouverie House • Fleet Street EC4.

FOR SALE

600

COMPLETE BALL MILL GRINDING PLANT by International Combustion, comprising chrome steel lined Hardinge Ball Mill, 8 ft. by 48 in. by Fraser & Chalmers, cubic capacity 298 ft., speed of Mill 22 r.p.m., driven by 220 h.p. 400/440/3/50 cycles motor through gearbox. Complete with Cyclone, Classifier or Double Cone Separator, 10,000 c.f.m. motorised Fan, Vertical steel Feed Hopper, Constant Weight Belt Feeder, etc.

PORCELAIN LINED BALL MILL by Steele & Cowlshaw, 26 in. by 23 in. long internally, 5 in. dia. charging port. Mounted in plain bearings on cast iron 'A' frames. Belt drive on Mill periphery with loose pulley. Quantity of pebbles available.

NO. 7 SWEETLAND PRESSURE FILTER by Dorr Oliver, Filter body of cast iron construction, 2 ft. 1 in. dia by 6 ft. 10 in. long internally, 20 woven wire leaves spaced at 4 in. with sight glass connections to mild steel manifold, 3 in. dia. flanged feed connection to body, 50 p.s.i. w.p.

TWIN-ROLL BUFLOVAK DRIER by Consolidated Products of U.S.A., rolls, 100 in. by 32 in. suitable for 100 p.s.i. w.p., driven by enclosed chain through reduction gear and vee rope drive from 5 h.p. 400/3/50 cycles motor giving roll speed approx. 5 r.p.m., take off speed approx. 40 f.p.m. Fitted with adjustable scraper knives and aluminium hood. TWO AVAILABLE.

STEAM JACKETED TILTING TYPE DOUBLE 'Z' BLADE MIXER by Baker Perkins, Universal type VIII. BB, capacity 88 imperial gallons, trough of cast iron and mild steel, 37 in. by 33 in. by 29½ in. deep internally, mixing blades running in glanded bearings and cored for steam heating. Steam jacket and blades suitable 100 p.s.i. w.p. Drive by 45 h.p. 400/3/50 cycles motor through gearbox, with ironclad isolating switch and wall mounting oil immersed stator and rotor starter.

MILD STEEL SINGLE TROUGH MIXER by Barron, 6 ft. 3 in. long by 48 in. wide by 44 in. deep, 6 in. centre bottom outlet with butterfly valve. Robust horizontal agitator comprising four blades with angled lifting flights, five to each blade. Shaft mounted in ball bearing housing. Drive by 7½ h.p. 440/3/50 cycles motor with starter. Body fully jacketed excluding ends stayed at intervals and suitable 40 p.s.i. w.p. Bolted cover. Mounted on four short legs. Agitator speed approx. 20 r.p.m.

CAST IRON ENAMEL STEAM JACKETED MIXER by Cannon, 10 gallons capacity, double flanged liner, 22 in. i.d. by 14 in. deep, bottom outlet with treacle valve. Anchor type agitator driven through gearing from F & L pulleys. Steam jacket suitable 40 p.s.i. w.p. TWO AVAILABLE.

SIZE 1A PATENT LIGHTNING CRUSHER with stainless steel liners, hammers, rotor and grids. Feed opening 9 in. by 10½ in. Grid aperture 2 in. by ¾ in. Pulley drive, shafts running in roller bearing plummer blocks. THREE AVAILABLE.

TOTALLY ENCLOSED SCREW CONVEYOR, 15 in. dia. right hand close bladed screw, 56 ft. long screw of ¼ in. thick mild steel blades welded to ¼ in. thick 2 in. dia. tube shaft. Trough and cover ⅝ in. steel 20 in. deep by 18 in. wide with 24 square bottom outlets. Drive through reduction gearing from 15 h.p. 400/440/3/50 cycles motor.

GEORGE COHEN

Sons & Co. Ltd.

Wood Lane, London, W.12.

(Shepherds Bush 2070)

Stanningley, Nr. Leeds.

(Pudsey 2241)

LUMP AND GRANULATED HARDWOOD CHARCOAL
Kiln cooked and absolutely clear from all extraneous matter. Available in granulated sizes—½ in., ⅜ in., ¼ in., ⅓ in., ⅙ in., ⅛ in. and dust.

JOSEPH JACK LIMITED,

6 Edington Place,

Dysart, Fifeshire.

FOR SALE: continued

Offers invited for: Once used fibre containers 21 in. diameter by 31 in. with lever closed metal lids. Excellent condition. Regular supplies available. Petrolite Limited, Birchill Road, Kirkby Industrial Estate, Nr. Liverpool.

MATERIALS WANTED

WANTED

Scrap Electrode Carbons, Graphite Offcuts, etc.

send samples and details of tonnage available to

FINE GRINDING LTD.,
Blackhole Mine, Eyam, Derby
'phone Eyam 227

OVERSEAS APPOINTMENTS

CHEMIST

Department of Agriculture, Tanganyika

For research work on coffee; including soil and plant analysis connected with nutritional problems and soil survey work.

Candidates (male) must have an honours degree in chemistry or equivalent qualification and not less than two years post graduate experience or training.

Appointment on contract/gratuity terms for one or two tours of 21-27 months with emoluments in scale £1,266-£2,448. Gratuity 25% of total substantive emoluments. Free passages. Generous leave. Furnished accommodation usually available at low rental. Children's education allowances.

Apply, stating full name and giving brief particulars of qualifications and experience, to **Director of Recruitment, Colonial Office, London, S.W.1,** quoting BCD.63/8/020/FI.

PLANT AND MACHINERY FOR SALE

Baker-Perkins Class BB "Double Naben" Bladed Steam Jacketed Mixers. Four—size 12 and Three—size 11, of 20 and 8 gallons respectively.

Oil Jacketed Double Trough Mixer 48 in. by 36 in. by 29 in. deep. Paddle Blades. Bottom Outlets.

Barron 'U' Sifter Mixer 96 in. by 33 in. by 33 in. with 10 H.P. A.C. Motor.

Gardner 'U' Sifter-Mixers 66 in. by 24 in. by 24 in. with 5 H.P. A.C. Motors. Four available, of modern streamlined design.

Horizontal 'U' Trough Mixers 48 in. by 18 in. by 22 in. Three—Tilting type, Paddle Blades. Glanded.

Over-Arm Twin-Blade, Tilting, 30 gallon Mixers with 3 H.P. Geared Motors. Five available.

Lying at our No. 2 Depot, Willow Tree Works, Swallowfield, Berkshire.

Apply: **Winkworth Machinery Limited, 65 High Street, Staines, Middlesex. Telephone 55951.**

Phone 55298 Staines

STAINLESS STEEL PLANT

S.S. Tanks 500, 400 and 220 galls. Cyl. Conical Bottoms.

S.S. Mixing Tank—300 galls. A.C.

S.S. Jac. Pasteurisers/Mixers 50, 100 and 150 galls.

S.S. Rect. Tanks 850 and 450 galls.

S.S. Spherical Still 6 ft. 6 in. diam.

S.S. Duplex 'Z' Mixer (Vacuum) 3 ft. by 3 ft. by 3 ft. deep.

S.S. Worm Conveyor—Trough 10 ft. by 5 in. by 5 in.

S.S. Homogeniser ½ H.P. 1,000 p.s.i. 25 g.p.h.

S.S. 'Hurrell' Homogeniser 5 H.P. 400/3/50.

Glass Lined Tanks 1,300, 2,000, 3,000, 3,250 and 3,600 galls.

(2) Jacketed Glass Lined Tanks 2,000 galls. each.

Mixers, Hydros, Condensers, Stills, Retorts, Reactors, etc.

Send for Lists.

HARRY H. GARDAM & CO. LTD.,

100 CHURCH STREET, STAINES.

CLASSIFIED ADVERTISEMENTS

Continued on page 828

Chemical Age Enquiry Service

For fuller details of equipment, apparatus, chemicals etc., in the advertisement or editorial page of Chemical Age, fill in the coupons below, ONE PER ENQUIRY, and return to us.

<p><i>Please send further details about</i></p> <p>.....</p> <p><i>mentioned on page</i> <i>of this issue.</i></p> <p><i>Name</i> <i>Position</i></p> <p><i>Firm</i></p> <p><i>Address</i></p> <p>.....</p> <p>Chemical Age Enquiry Service.</p>
<p><i>Please send further details about</i></p> <p>.....</p> <p><i>mentioned on page</i> <i>of this issue.</i></p> <p><i>Name</i> <i>Position</i></p> <p><i>Firm</i></p> <p><i>Address</i></p> <p>.....</p> <p>Chemical Age Enquiry Service.</p>
<p><i>Please send further details about</i></p> <p>.....</p> <p><i>mentioned on page</i> <i>of this issue.</i></p> <p><i>Name</i> <i>Position</i></p> <p><i>Firm</i></p> <p><i>Address</i></p> <p>.....</p> <p>Chemical Age Enquiry Service.</p>

★ *Detach this page complete then fold as marked overleaf to use the post-paid reply folder*

Chemical Age

ENQUIRY SERVICE



☐ This is a special service for readers of

CHEMICAL AGE

☐ It is designed to give fuller information on equipment, apparatus, chemicals etc., mentioned in this issue—whether in the editorial text or in an advertisement

☐ Cut out the whole of this page, fold as instructed with post-paid address on the outside



Chemical Age

154 Fleet Street, London, E.C.4

Tel.: Fleet Street 3212

2nd FOLD

Postage will be paid by the Licensee		No Postage Stamp necessary if posted in Great Britain or Northern Ireland
--------------------------------------	--	---

1st FOLD

BUSINESS REPLY FOLDER
Licence No. 2501

CHEMICAL AGE
154-160 FLEET STREET
LONDON, E.C.4

3rd FOLD

CUT ALONG THIS DOTTED LINE

FIRST FIND THE RIGHT PEOPLE

A leading technical college chose TRF, the Stainless Steel specialists, to build this Fermentor. Why TRF?

Because, very sensibly, they preferred to deal with the specialists . . . the people with the right solution to Stainless Steel problems. Stainless Steel could be playing a major part in *your* new plant. Much better speak to the right people about it . . . TRF.

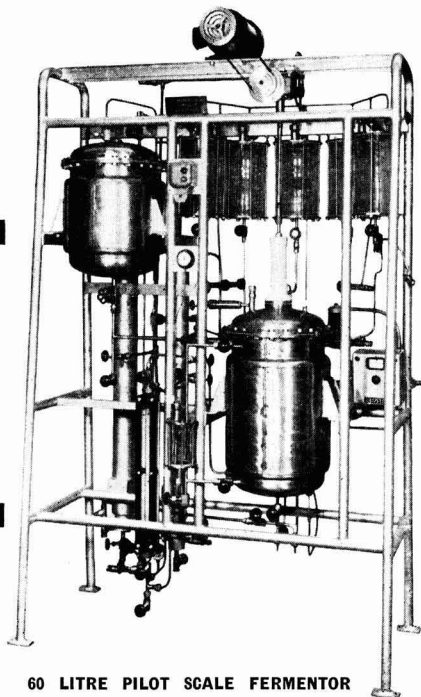

**60 LITRE PILOT SCALE FERMENTOR
WITH MEDIUM PREPARATION VESSEL
AND GLASS ADDITIONAL VESSELS.**



TAYLOR RUSTLESS FITTINGS CO LTD

HEAD OFFICE: RING ROAD, LOWER WORTLEY, LEEDS
Tel: LEEDS 638711
LONDON OFFICE: 14 GREAT PETER ST. LONDON, W.1
Tel: Abbey 1576

Compressors for Industrial Gases

Moderate speed compressors carefully designed for reliability, are available in both vertical and horizontal arrangement from small capacities up to units of over 5,000 H.P. and very high pressures.

The illustration shows two vertical, three crank, six stage compressors each with a capacity of 3,000 cu. ft. per minute and a delivery pressure of 326 atmospheres.

Maschinenfabrik **Esslingen** Germany

LLOYD & ROSS LTD

58 VICTORIA STREET S.W.1
TELEPHONE: VICTORIA 4873

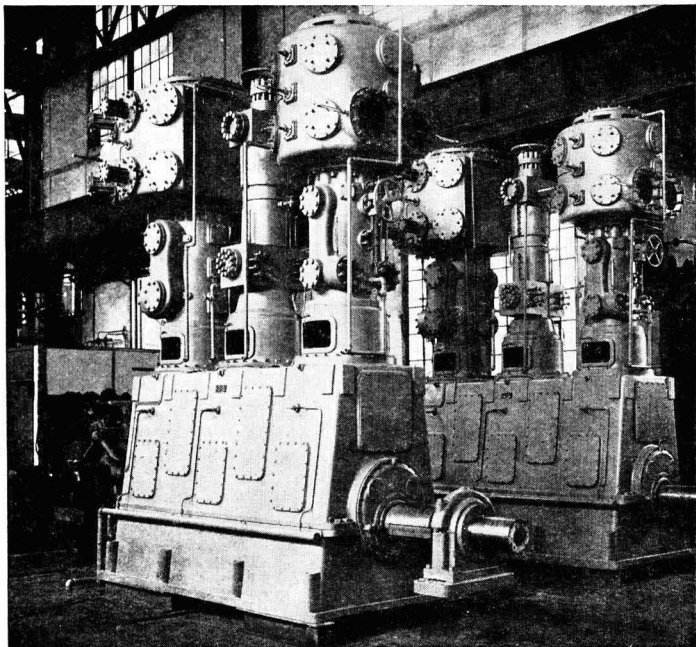

Recovery of ferrous sulphate heptahydrate

The vacuum crystallization process for the regeneration of pickle liquor offers outstanding advantages for a very wide range of pickling capacities at a ferrous sulphate content of 12 to 15% and higher and at appropriate sulphuric acid concentrations.

Continuous operation

Uniform, low ferrous sulphate content in regenerated liquor independently of possible variations in the cooling water and air temperatures during the seasons

Low energy requirements

Steam saving because of heat exchange

Simple and trouble-free operation over long periods

Low maintenance cost

No loss of acid

Lurgi has been handling the design and construction of pickle liquor regeneration plants for more than 35 years.

Pickle Liquor Regeneration by Vacuum Crystallization

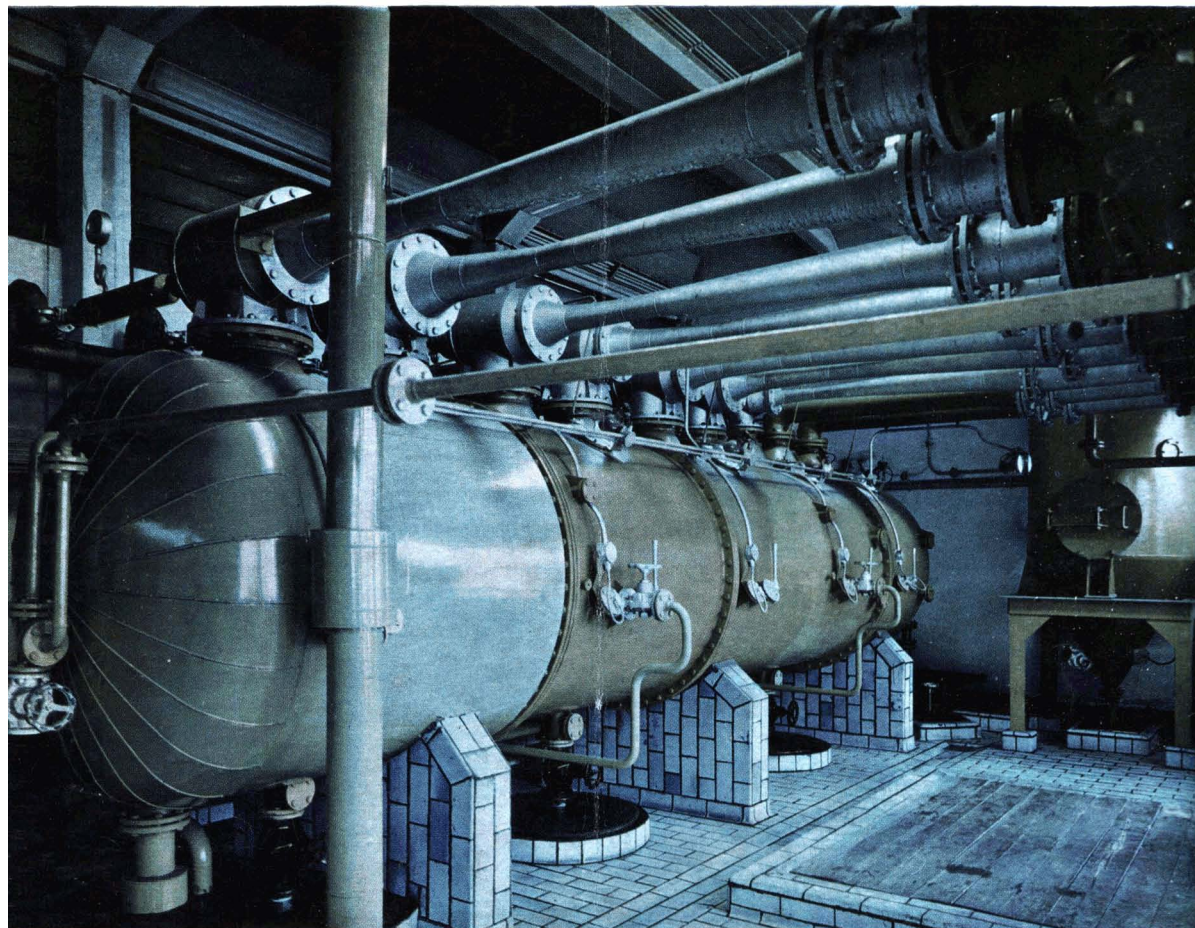

Vacuum crystallizer in regeneration plant for a maximum pickling capacity of 40,000 tons per month of strips

LURGI GESELLSCHAFT FÜR WÄRMETECHNIK MBH
FRANKFURT (MAIN) · LURGIHAUS

Associated Lurgi companies:
Lurgi Apparatebau Gesellschaft mbH
Lurgi Gesellschaft für Chemie und Hüttenwesen mbH
Lurgi Gesellschaft für Chemotechnik mbH
Lurgi Gesellschaft für Mineralöltechnik mbH