

Chemical Age

incorporating

PETROCHEMICALS and POLYMERS / 23 December 1961. Vol. 86. No. 2215

THE WEEKLY NEWSPAPER OF THE CHEMICAL INDUSTRY

I.C.I.—COURTAULD'S
MERGER (P. 991)
VINYL ACETATE
DUTY (P. 992)
ACETYLENE FROM
METHANE (P. 997)

THIS IS THE TIME FOR...

GOOD WISHES...GOOD RELATIONS...

...GOOD SERVICE

THEY'RE SYNONYMOUS WITH

SPENCER CHAPMAN & MESSEL LTD

It is our hope that 1962 will
be a year of prosperity for all

BORAX HOUSE • CARLISLE PLACE • LONDON, S.W.1
Telephone: TATe Gallery 8215
WORKS: SILVERTOWN E.16

COMMERCIAL
AND PURE
ACIDS
FOR ALL PURPOSES
SULPHURIC - OLEUM
BATTERY - HYDROCHLORIC
NITRIC - DIPPING
DISTILLED WATER (Pure)

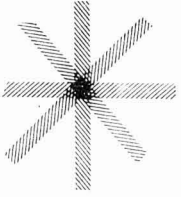

and

NOW!

All over Britain more and more manufacturers are ordering Aiton PWV mixers. Specially built for long life and reliability PWV mixers serve a variety of processes:- dissolving, blending, chemical reaction, absorption, heat transfer etc.

Aiton PWV mixers are vibrationless, made to the highest quality standards, and offer maximum efficiency with minimum maintenance.

Sizes range from 1/6 h.p. to 100 h.p. — low, medium and high speed operation.

Full details of the Aiton range of mixers, mixing vessels and other specially designed equipment, will be supplied on request.

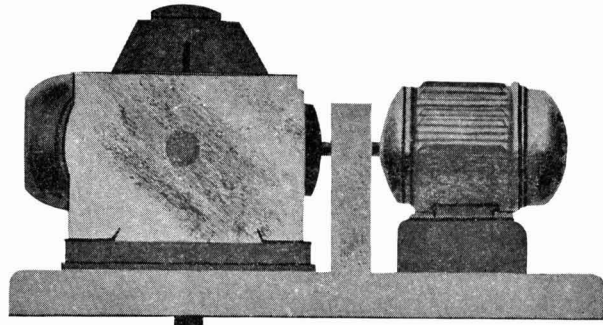

**STONE & WEBSTER
ORDER
84 AITON
PWV MIXERS
FOR BRITISH
TITAN'S FACTORY
IN CANADA**

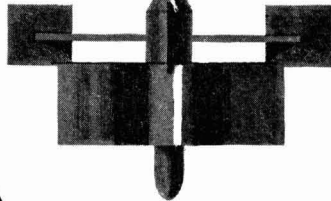

AITON

Mixers and Mixing Vessels

Q·V·F *Glass* PUMPS

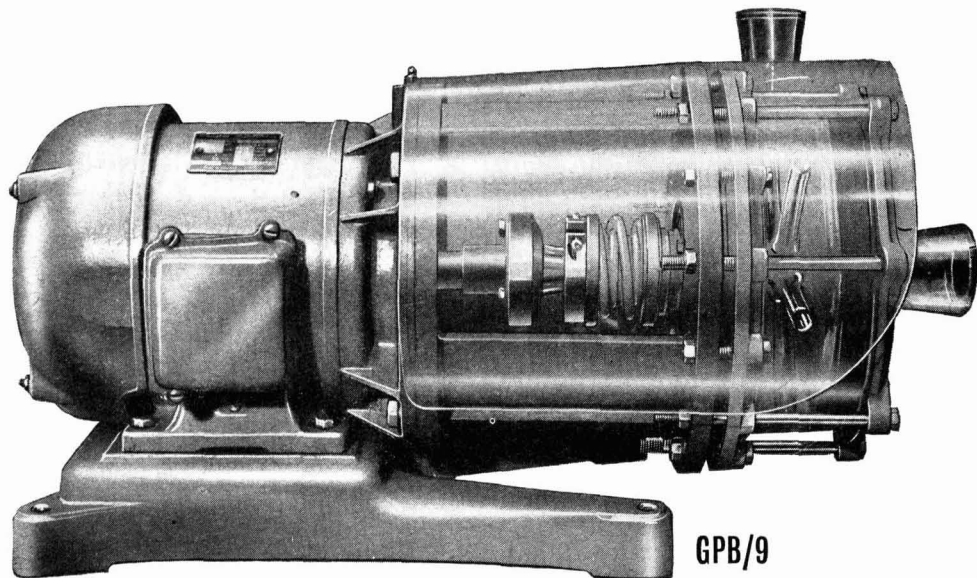

GPB/9

...with outstanding Chemical and Thermal shock resistance properties!

Q.V.F. Glass Pumps have been specially developed for use in the Chemical Industry for the conveyance of corrosive liquids.

Made in two sizes (types GPB/6 and GPB/9) they are of the centrifugal type and run at 1,400 r.p.m. A glass impeller of simple design thrusts the liquid through the tangential outlet of the glass casing. A mechanical seal is used having a spring-loaded P.T.F.E. bellows rotating with the shaft.

The complete pump forms a compact and efficient unit and the motor is interchangeable.

Other outstanding advantages of this revolutionary pump are fully described in a new folder—free on request.



The Chemical Engineers in Glass

DUKE STREET · FENTON · STOKE-ON-TRENT · STAFFS

Telephone : STOKE-ON-TRENT 32104/8 Grams : Q.V.F. Stoke-on-Trent Telex

INDEX TO ADVERTISERS

The first figures refer to advertisements in Chemical Age Directory & Who's Who, the second to the current issue

Page	Page	Page	Page	Page	Page
		276	Bulwerk Transport Ltd.		Electro-Chemical Engineering Co.
		66	Burnett & Rolfe Ltd.		Electrothermal Engineering Ltd.
			Burts & Harvey Ltd.		Elga Products Ltd.
164			Bush Beach & Segner Bayley Ltd.	Book	Mark Elliott, H. J., Ltd.
148		194	Bush, W. J., & Co. Ltd.		Elliott Brothers (London) Ltd.
121		124	Butterfield, W. P., Ltd.	145	Elmatic
			Butterworths Scientific Publications		Endecotts (Filters) Ltd.
157			C. T. (London) Ltd.		Engelhard Industries Ltd. (Baker Platinum Division)
145		245 & 249	Calmic Engineering Co. Ltd.		Evans Electrostenium Ltd.
123			Carless, Capel, & Leonard Ltd.	990	Evered & Co. Ltd.
130		175	Causeway Reinforcement Ltd.		
120			Chappell, Fred, Ltd.	990	
123			Chemical Age Enquiries		Farbwerke Hoechst A.G.
130			Chemical & Insulating Co. Ltd., The		Farnell Carbons Ltd.
160			Chemicals & Feeds Ltd.	168	Feltham, Walter H., & Co. Ltd.
			Chimimport	152	Ferris, J. & E., Ltd.
136		158	Ciba (A.R.L.) Ltd.	279	Ferrostatics Ltd.
211			Ciba Clayton Ltd.		Fielden Electronics Ltd.
		164	Citenco Limited		Firkins, G. & A., Ltd.
			Classified Advertisements	171	Flight Refuelling Ltd.
		169	Clayton, Son & Co. Ltd.		Floor Engineering & Construction Co. Ltd.
		138	Clydesdale Chemical Co. Ltd.	185	Fireproof Tanks Ltd.
			Cohen, George, Sons & Co. Ltd.		Foxboro-Voxall Ltd.
		141	Cole, R. H., & Co. Ltd.		Fraser, W. J., & Co. Ltd.
			Colt Ventilation Ltd.		Freeman, William, & Co. Ltd.
			Colvilles Limited	207	Fullers' Earth Union Ltd., The
		131	Comet Pump & Eng. Co. Ltd., The		
		269	Commercial Plastics Ltd.	122	G.O. Parachute Co. Ltd.
			Consolidated Zinc Corporation Ltd.	168	Gallenkamp, A., & Co. Ltd.
			Constable & Co. Ltd.		Gascoigne, Geo. H., & Co. Ltd.
			G/Card Constant Engineers Ltd.		Geigy Co. Ltd., The
			Constructors John Brown, Ltd.	183	General Precision Systems Ltd.
			Controlled Convection Drying Co.		Glass Manufacturers' Federation
			Cooke, Troughton & Simms Ltd.		Giusti, T., & Sons Ltd.
			Coulter Electronics Ltd.		Glebe Mines Ltd.
			Cox, Arthur H., & Co. Ltd.		Glen Creston Ltd.
			Cromil & Piercy Ltd.		Goodyear Pumps Ltd.
			Crosfield, Joseph, & Sons Ltd.	167	Graviner Mfg. Co. Ltd.
			Crossley, Henry (Packings) Ltd.	172	Greiff, R. W., & Co. Ltd.
		180	Crow Carrying Co. Ltd., The		
		133	Cruikshank, R., Ltd.		Halex (Bex Industrial)
		159	Curran, Edward, Engineering Ltd.	144	Haller & Phillips Ltd.
		219	Cyanamid of Great Britain Ltd.		Hamilton Company Inc.
		213	Cyclo Chemicals Ltd.	156	Harris (Lostock Gralam) Ltd.
		126	Cyclops Engineering Co. Ltd., The		Harvey, G. A., & Co. (London) Ltd.
		235	Dalglish, John, & Sons Ltd.	6	Haworth, F. (A.R.C.) Ltd.
		152	Danks of Netherpton Ltd.		Headfield Industries Ltd.
			Davenport Engineering Co. Ltd.		Hearson, Charles, & Co. Ltd.
		136	Davey & Moore Ltd.		Helmets Ltd.
		144	Davey, Paxman & Co. Ltd.	161	Hercules Powder Co. Ltd.
			Day & United Instruments Ltd.		Hindle, Joshua, & Sons Ltd.
		140	Dawson, McDonald & Dawson Ltd.	164	Holden, Chris., Ltd.
			Deutsche Steinezeug-U. Kunststoffwaren-fabrik		Howard Pneumatic Eng. Co. Ltd.
		143	Distillers Co. Ltd., The	151	Humphreys & Glasgow Ltd.
		139	Distillers Co. Ltd., The (Chemical Div.)		Huntingdon, Heberlein & Co. Ltd.
			Distillers Co. Ltd., The (Industrial Group)		I.C.I. (Billingham)
		135	Dorr-Oliver Co. Ltd.		I.C.I. Catalysts
		131	Doulton Industrial Porcelains Ltd.		I.C.I. General Chemicals Division
			Dow Chemical International S.A.		I.C.I. Ltd. Heavy Organic Chemicals
		154	Dowling Lime & Stone Co. Ltd.		I.C.I. Metals Titanium D.
		127	Dryden, T., Ltd.		I.C.I. Nobel Chemicals
			Dunlop Rubber Co. Ltd. (G.R.G. Dunclad)		I.C.I. Plastics—Darvic
			E.C.D. Ltd.		I.C.I. Plastics—Fluon
			Electric Resistance Furnace Co.		I.C.I. Plastics—Kralastic
					I.C.I. Ltd. (Plastics Division), Corvic
					I.C.I. (Florube) Ltd.
					I.M.P.A. Ltd.

COPPER PLANT

for the
CHEMICAL TRADE

Established 1825

BLUNDELL & CROMPTON
LIMITED

WEST INDIA DOCK ROAD,
LONDON, E.14

Phone : East 6001 & 3838 (8 lines)
Grams : Blundell Phone London

STILLS
RECTIFYING COLUMNS
CONDENSERS

Autoclaves . Calandrias
Vacuum Pans . Boiling Pans
Pipework . Coils . Etc.

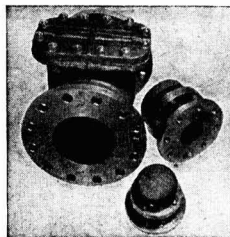

FLAME TRAPS
TO OUR OWN
DESIGN AND SIZE
IN ANY METAL

RICHMOND WELDING COMPANY

ESTABLISHED 1929

RICHMOND ROAD, BRADFORD 7

TELEPHONE 25405

THE ALL STAINLESS STEEL TANKER SERVICE

FRED CHAPPELL LTD

GRANGE ROAD • BATLEY • YORKS

Telephones : BATLEY 4242-3-4

EDIBLE OILS - SYNTHETICS - ACIDS Etc.

DELIVERIES THROUGHOUT THE U.K. or CONTINENT

CONTRACT OR SPOT HIRE RATES

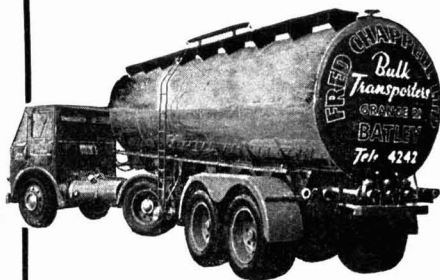

CARLESS

*Hydrocarbon
Solvents and
Diluents*

SPECIAL NAPHTHAS

- Specific gravity 0.860—0.865
- Distillation range 145°C—180°C
- Flash point minimum 87°F
- Specifications varied to meet requirements of individual customers

Let us send you a sample and a quotation

CARLESS, CAPEL & LEONARD, LTD.
HACKNEY WICK, LONDON, E.9 Amherst 5500

Fire Prevention Standard Recommendations

THIS SYSTEM OF STANDARD RECOMMENDATIONS for fire prevention was devised by the Kent County Brigade.

'..... streamlines paper work in the preparation of fire prevention reports.' **Municipal Journal**

'..... intelligent standardisation of form and wording makes for more efficient work all round.' **T.L.S.**

8s. 6d. [postage paid]

Published by **ERNEST BENN LIMITED**
Bouverie House • Fleet Street • London • EC4

VOL. 86 No. 2215

DECEMBER 23 1961

Telephone: FLEet Street 3212 (26 lines)

Telegrams: Benformula - London E.C.4

Editor Manager
M. C. HYDE R. C. BENNETT

Director N. B. LIVINGSTONE WALLACE

Midland OfficeDaimler House, Paradise Street,
Birmingham. [Midland 0784-5]**Leeds Office**Permanent House, The Headrow,
Leeds 1. [Leeds 22601]**Scottish Office**116 Hope Street, Glasgow C2.
[Central 3954-5]**IN THIS ISSUE**

Duty on vinylacetate	992
Project news: Refinery planned in Essex; Midsil expansion	993
Distillates	994
I.C.I. Bid for Courtaulds	995
Acetylene-from-methane process	997
In Parliament	997
I.C.I. streamline research facilities	998
Production census for 1960	998
Effluent at phosphorus plant	999
World rubber consumption	999
New D.C.L. petrochemical film	1000
Overseas news	1001
Bookshelf	1003
People in the news	1004
Commercial news	1005
Market reports	1005
Trade notes	1006
New patents	1007

Annual subscription is: home, 57s 6d, overseas, 65s, single copies 1s 9d (by post 2s)

Chemical Age

Incorporating

PETROCHEMICALS and POLYMERS

BOUVERIE HOUSE • 154 FLEET STREET • LONDON • EC4

OUT WITH A BANG!

A YEAR which has probably witnessed more large scale chemical industry developments than any other, ends with the biggest news in the industry's recent history. Like most world chemical companies, Imperial Chemical Industries Ltd. have run into difficulties with profit margins cut, and plants running at below capacities in many instances.

Despite these and other difficulties, which have included the closing of their acrylonitrile plant and problems of raising labour to start construction at their £100 million Rotterdam site, I.C.I. are still confident enough to make a £180 million bid for one of Europe's largest fibre groups—Courtaulds Ltd. As stated in p. 995, the outstanding reason behind this dramatic take-over bid is the man-made fibre industry and a desire to see a fully integrated combine able to produce and market a complete range of fibres as well as to supply all the necessary raw materials.

Apart from reactions on the part of directors of Courtaulds or their shareholders, there are already signs that this gigantic take-over attempt will meet stiff opposition. I.C.I. will have some fairly strong arguments to counter and undoubtedly the House of Commons will hear much talk of monopoly. On Monday, Mr. S. P. Chambers, chairman of I.C.I., showed the line likely to be taken to counter complaint on this particular score.

He firmly believed that Britain would enter the Common Market. Any position that I.C.I. might hold now as a monopoly producer in any particular products would then disappear for the British home market would become part of the broader European Common Market. It is in fact a desire to meet the stiff competition on the part of European and U.S. fibre producers that led to I.C.I.'s initial approach to Courtaulds.

The world's man-made fibre market—including all synthetics—is expected by I.C.I. to expand at a compound rate of between 10 and 12% per annum over the next few years, with a slightly faster rate of development in Europe. This then is the prize that I.C.I. have in their sights.

In the non-cellulosic man-made fibre field, U.K. production, which totalled 48,000 tonnes in 1960 should see a 100% rise by 1965. In recent years Courtaulds have developed in other fields, notably chemicals, films and paints, but these are secondary interests to fibres in the current bid. Big savings in overheads are looked for by I.C.I., notably in capital spending, marketing and research. In the latter case, the savings would doubtless be substantial for there is much duplication of research effort on man-made fibres. With the current scarcity of scientists, the fairly large number of fibre research workers that would be displaced should be absorbed quite easily within I.C.I.

The merger would bring together I.C.I.'s nylon 66, polyester and polypropylene fibres with Courtaulds viscose, acetate, triacetate, acrylic and polythene fibres, and planned production of both companies of nylon-6. Truly a formidable combination.

P.V.A. producers seek duty-free imports of vinyl acetate

THAT an application for a U.K. anti-dumping duty on vinyl acetate should be followed a year later by a request for the removal of import duty on this product is a somewhat dramatic turn of events. The monomer producers' plea a year ago for an anti-dumping duty on imports from Italy and Switzerland was turned down by the Board of Trade.

Now, despite the fact that U.K. production is sufficient to meet current demand of around 18,000 to 19,000 tons a year, producers of polyvinyl acetate have asked the B.o.T. to allow duty-free imports of the monomer. It is understood that the present approach is based on allegations that imported monomer is available at cheaper prices than U.K.-produced vinyl acetate and that cheap material is necessary to allow polymer producers to export to the Continent.

The two U.K. producers of vinyl acetate—British Celanese Ltd. (of the Courtaulds Group) and Hedon Chemicals Ltd. (jointly owned by the Distillers Company Ltd. and Shawinigan of Canada) do not make the polymer. On the Continent it is more usual for one firm to make both monomer and polymer. There are some 12 British producers of polyvinyl acetate.

U.K. consumption of vinyl acetate has been showing a growth rate of 10% per annum, usage having risen to the current figure from 12,000 tons in 1958. As stated in CHEMICAL AGE, 28 October, p. 665, this figure is expected to rise to some 22,000 tons in 1963 and to between 26,000 to 27,000 tons by 1965. U.K. usage is estimated as follows:

	%
Paints	45
Copolymers	15
Adhesives	10-12
Miscellaneous	28-30

Production in this country is adequate

to meet most domestic needs and to cut out about half the current import total. Capacity of the Hedon facilities at Salt End, Hull, is reportedly almost double that of British Celanese at Spondon. Both companies have recently completed expansion projects; both plan further increases in capacity.

In view of the current production and consumption pattern, it is difficult to see how this application can succeed, particularly since the Board of Trade a year ago failed to give the British producers protection against vinyl acetate sold in this country at lower prices than in the country of origin.

So far as the present request for removal of duty is concerned, the B.o.T. will supply a statement of the applicant's case to firms wishing to make representations, provided that it is treated as confidential and that comments made can be passed to the applicant for counter comment.

Requests for copies of the statement should reach the B.o.T. Tariff and Import Policy Division, Horse Guards Avenue, London S.W.1 not later than 15 January. Comments on the application should be filed by 5 February.

H. A. Smith form new division for resins

FORMATION of a separate Resin Division is announced by H. A. Smith Ltd., of Braunston, near Rugby. Establishment of this new division is attributed to a greatly increased demand for the Tenax-tex range of synthetic resin emulsions. New laboratories have been set up to undertake further development work on these specialised polymer products, and to provide an extension of the technical service facilities necessitated by the very wide range of applications.

B.o.T. translate C.M. external tariff for chemicals and plastics

An English translation of the Common External Tariff of the European Community, which will be published in eleven parts and available from H.M. Stationery Office, has been prepared by the Board of Trade. One part, dealing with machinery electrical equipment, vehicles, aircraft, vessels, etc., has already become available and the next two parts due for publication are Chapters 25-30, dealing with mineral products, chemicals (inorganic and organic) and pharmaceuticals; and Chapters 31-40, on fertilisers, dyes, soaps, explosives, photographic and cinematographic goods, artificial resins and plastics materials, rubber and synthetic rubber.

It is hoped to complete publication of all the remaining parts by the end of February.

*The Editor, the
Advertisement
Manager and Staff
of 'Chemical Age'
wish all their
Readers and
Advertisers a
Happy Christmas
and Prosperity in
the New Year*

Floodlighting of Croda's Yorkshire H.Q.



Recently installed floodlighting makes an impressive setting for Cowick Hall, Snaith, Yorks, headquarters of the Croda Organisation Ltd. (see also 'Distillates')

Polish chemical plant orders for Scotland?

POLISH industrialists are to visit Scotland in January to discuss the purchase of chemical, petrochemical, mining, ship-building and heavy engineering equipment. This follows a visit to Poland by Scottish Council (Development and Industry) delegates representing a number of the major heavy engineering undertakings. They were given a good reception by Government and industrial bodies and interest was shown in purchase of Scottish equipment, provided that price and delivery was satisfactory.

Earlier, the Scottish Council launched a similar visit to Eastern Europe, where considerable interest was shown in capital equipment for industrial development works. There are some hopes that substantial business can be done in the appropriate section.

Project News

A.E.A. PLACE DRAGON FUEL ELEMENT CONTRACT IN GERMANY

AN order for the fuel element assembly line for the gas cooled reactor of the Dragon project at Winfrith Heath has been awarded to **W. C. Heraeus GmbH**, of West Germany, through their U.K. agents, Fleischmann (London) Ltd. The order as placed by the **U.K. Atomic Energy Authority** on behalf of the O.E.C.D. project, the international undertaking in which the A.E.A., the Euratom countries, Austria, Denmark, Norway, Sweden and Switzerland are participating. Aims of the project are to achieve major improvements in the field of high-temperature gas-cooled reactions.

The fuel rods, about 7 ft. long, are being degassed and then brazed at a high vacuum of 5×10^{-5} mm Hg. Degassing and brazing temperatures up to 2000°C are provided. One fuel element consists of an assembly of seven such rods connected at the top by a graphite block and at the bottom by welded metal cones. The length of a fuel element is approximately 8 ft.

The Heraeus plant, consisting of an interconnected line of glove boxes and various vacuum furnaces, allows the assembling, degassing, brazing and complete testing of the fuel elements under a controlled atmosphere. The boxes are designed to withstand a vacuum.

Heraeus already hold an important contract for parts of the German Krupp-Brown-Boveri reactor project and have supplied a large number of vacuum furnaces and various vacuum installations for practically all European atomic research establishments.

Baglan Bay contract for Taylor Woodrow

● CONTRACT worth about £130,000 has been awarded to **Taylor Woodrow Construction Ltd.**, by Stone and Webster Engineering Ltd., to carry out foundation work and underground piping installations for a new ethylene and butadiene unit at the **British Hydrocarbon Chemical Ltd.** complex at Baglan Bay, near Port Talbot, South Wales. Work, which started at the end of October, is expected to be completed by mid-1962.

Continental firm involved in Essex refinery plans

● ONE of the "up and coming continental concerns who are seeking to break the existing oil ring" is planning an oil refinery in the Tollesbury area of Essex, across the River Blackwater from the Bradwell Nuclear Power Station. Although the company has not yet been named, it has been stated that the refinery could cost in the region of £28 million.

Mr. E. A. Baker, acting for the oil company agents, has made an application to Maldon Rural Council for planning permission to build an oil tanker terminal and a refinery on a 140-acre marshland site. The council has asked Mr. Baker to produce a Board of Trade certificate and other details before considering the application.

Further stage in Midsil Barry expansion

● EXPANSION of the Barry silicones plant of **Midland Silicones Ltd.** is taken a stage further with the award of a contract to design and construct tank farm additions complete with piping network. This will give an increased storage capacity of 120,000 gall. of raw materials and products. The contract has been awarded to the **Chemical Engineering Division of the Sturtevant Engineering Co. Ltd.**, London, and work is scheduled for completion by June 1962.

Sturtevant's Chemical Engineering Division already have in hand for Midland Silicones the design and construction of a new reactor unit, and the work will be completed this year.

Equipment contract

Remote handling contract for Nuclear Equipment

● A £26,000 ORDER for remote handling equipment has been obtained by **Nuclear Equipment Ltd.**, Crossroads House, Watford, from the English Electric Co. Ltd. The equipment, including a mechanical arm with a capacity of 750 lb and 4 pairs of master slave manipulators, will be used for remote handling at Sizewell nuclear power station, Suffolk.

Electromagnetic unit solves stirring problem in atomic energy work on chemicals

THE problem of stirring solutions in glove-box work, for which motor-driven stirrers and standard laboratory magnetic stirrers prove unsuitable for various reasons, has been overcome at the Atomic Energy Research Establishment, Harwell, by the development of an electromagnetic stirrer designed for work in a corrosive atmosphere, and consisting of a simple three-phase oscillator, placed outside the glove box, which energises the stirrer head within the box. The head consists of a set of fixed coils, completely encapsulated in a cold-setting epoxy resin; these, when energised, generate a dynamic magnetic field which

New computer aids Distillers research

A NEW computer, the National-Elliott 803, which has been acquired by the research department of the Distillers Co. Ltd., at Great Burgh, near Epsom, is being used for a wide variety of research problems in chemical engineering, mathematics, statistics and physical chemistry as well as operational research on behalf of the company's operating divisions.

This machine, replacing an earlier model, is both larger and more than twice as fast. The addition of an automatic floating-point arithmetic unit has enabled a further five-fold increase in speed of calculation to be made.

Although under the general control of the mathematics section, the machine is used by a wide cross-section of the scientific staff who write their own programmes employing a simplified coding system known as Autocode.

Rumanian chemical officials visit Evode

A GROUP of Iron Curtain paint experts from Poland, Rumania and Czechoslovakia recently visited Evode Ltd. of Stafford. The party included Mr. S. Srodka (a director of the Lodz paint factory, Poland), Mr. B. Nieroda and Mr. K. Kolodziej (of the Wroclawek paint factory), Mr. J. Stanek and Mr. L. Danek (Czechoslovakia) and Mr. Blager and Mrs. Voiculescu (both of the Rumanian Ministry of Chemical Industries).

They were welcomed by Dr. H. Simon (managing director of Evode Ltd.), Mr. J. E. Forman (director) and Mr. E. A. Duligan (manager of Surface Coatings Division).

New approved names for drugs

The following list of approved names has been issued by the General Medical Council: Acridile will be known as methyl cysteine; clistin as carbinoxamine; duphaston as hydrogesterone; monase as eptyptamine; palaprin as aloxiprin; penspek as phenbencillin; synalar as fluocinolone; toreacan as thiethylperazine; ultran as phenaglycolol; and welldorm as dichloralphenazone.

rotates a small polythene-enclosed magnet in the solution to be stirred.

This stirrer has been found to satisfy the original requirements, will stir up to 400 ml. of solution, and can deal with solutions containing about 50% glycerol. Total overall cost is not much more than that of the standard stirrer and, since in many cases it will be acceptable to supply several heads alternately from one control unit, it could easily prove to be less, on the whole.

Details of the unit are given U.K.A.E.A. Research Group Memorandum AERE-M941, available from H.M.S.O., price 1s 2d.



★ Who leaked the biggest industrial story of the century? Mr. Paul Chambers, I.C.I.'s economist chairman, said on Monday that someone posing as a member of the I.C.I. Press staff had phoned the national newspapers on Sunday telling them of the company's offer for Courtaulds.

Although I.C.I. made the initial approach to Courtaulds some four months ago, and although the discussions were described as extremely amicable, the actual terms were only communicated to Courtaulds on Friday last—two days before the leak. Courtaulds have not had time to discuss the terms, particularly as their chairman was on the high seas at the time, returning to the U.K. on Friday this week.

In view of the wide nature of the leak, Mr. Chambers decided in that it was in everybody's interests to make a prompt statement as soon as possible, preferably before Stock Exchange dealings started on Monday. Because it had been agreed with Courtaulds that in the absence of a leak nothing should be published until a joint statement could be made in the New Year, I.C.I. tried to contact Courtaulds' deputy chairman, Sir Alan Wilson, to tell him of their planned announcement. Sir Alan was due in London just after 9 a.m. on Monday morning, but his train was fog bound, and he was contacted on its arrival at about 10.15 a.m.

Meanwhile the Stock Exchange has been informed, a Press conference called and an official statement issued to the news-agencies. Net result, a nice Xmas present to Courtaulds' stockholders on Monday with a rise of 9s to 39s in the value of their shares. I.C.I.'s bid puts a price of 41s 9d on Courtaulds' shares.

★ AN extension of training schemes throughout the country next year is the positive answer the accident prevention movement is giving to the current rise in industrial accidents. It is to be hoped that more firms will take advantage of the various schemes. Certainly in the chemical industry, the idea of safety training has been firmly adopted by progressive management as an important contribution to increased productivity, as well as from the welfare aspect.

Last week, the Birmingham Industrial Accident Prevention Group opened a new extension to their Acocks Green training centre, which will play an important part in the 1962 drive. New courses here include studies on plastics.

There are altogether 58 groups in Britain, many of which conduct training through apprentice junior groups. For 22 years the Industrial Safety Division of

the Royal Society for the Prevention of Accidents has been teaching the basic principles of accident prevention on its regular residential courses to those proposing to become full-time industrial safety officers. Other members of management who are responsible for safety in their factories are also accepted. Many firms intend to appoint safety officers in fact, nowadays insist that applicants must be R.o.S.P.A. trained.

★ It is not often that I can write about one of Britain's stately homes, but the recent installation of floodlighting at Cowick Hall, headquarters of the Croda Organisation, is my excuse on this occasion. This building is now lit from dusk to midnight and, as shown in my photograph on p. 992, the effect is impressive.

Cowick Hall was built in the early part of the 18th century and for many years was the seat of the Dawney family, of which Viscount Downe is the head. After various changes of ownership, Croda Organisation acquired Cowick Hall as their H.Q. in 1956.

Situated at Snaith, near Goole, in the West Riding of Yorkshire, the building is one of the finest examples of its type of architecture in the country. It has been extensively renovated and improved during Croda's occupation. It houses the group's administrative and co-ordinating departments with a staff of about 60, who work in ideal surroundings of beautiful gardens and parklands.

★ A POTENTIALLY important use of rigid polyurethane foams that has not hitherto been publicised, but which marks a further infiltration of plastics into shipbuilding, is for the filling of ships' rudders. Advantages claimed are greater stability, since the water is kept out, and protection against internal corrosion, and several rudders have been filled successfully over the last few years.

Simplicity and economy of the filling operation has been enhanced by the recent development by I.C.I. Dyestuffs Division of a new system in which Arcton 11 (trichlorofluoromethane) supplements the blowing action of the carbon dioxide, giving foams of much lower density and of high (95%) closed cell content. Better and less cumbersome dispensing equipment has also become available. Trials of ships' rudder filling carried out by I.C.I. Dyestuffs technicians in conjunction with an experienced firm of insulation contractors have resulted in striking improvements

as compared with earlier polyurethane foam systems.

★ THE Continental oil concern bidding for a refinery site on the River Blackwater in Essex (see 'Project News') has not been named, but of the three probables, Compagnie Francaise des Petroles, Petrofina and E.N.I., I believe that the first named is the most likely. With more than 100 petrol stations under the Total symbol, they have shown the most aggressive interest in the U.K. market to date.

E.N.I., who recently set up A.G.I.P. (Great Britain) Ltd. to bring their well-known six-legged dragon symbol to the U.K., have yet to build up a chain of filling stations. As stated in this journal recently (25 November, page 849), Regent Oil Co. have already revealed their intention to build a refinery in this country.

Before the new mystery entrant can settle on the marshy banks of the Blackwater, many hurdles will have to be overcome. Strong protests can be expected from fishing and yachting interests.

★ FOLLOWING reports in CHEMICAL AGE over the past few weeks of steps planned or taken in Western Europe against dumping of U.S. plastics on European markets, it is now stated that Union Carbide Europe S.A., Geneva, the European selling body of the U.S. Union Carbide group, have raised by 10% the price of top-quality polythene for foil production on the West German market. Former prices, say the firm, have been too low in view of technical advice services, market promotion and similar service facilities.

From Bonn it is announced this week that the Federal German Ministry for Economic Affairs is now studying the German chemical industry's request that an anti-dumping duty should be introduced in the case of polythene imports from the U.S.

★ ALTHOUGH I have dropped more than one brick in this column and put my foot in it on more than one occasion, I have never had the bad luck to drop a $\frac{3}{4}$ cwt. metal coupling on my foot. This happened to Mr. R. E. Deering at Monsanto's Fawley works recently, but because he was wearing safety shoes, Mr. Deering suffered no injuries.

This incident gained him membership of the 'Golden Shoe Club' and he is now entitled to wear the club's badge and tie, recently presented him by Fawley works manager, Dr. E. W. Bodycote. Safety boots, goggles, helmets and other items of protective clothing are a 'must' for the modern chemical industry worker, but alas are not likely to protect a Fleet Street diarist from the occasional slings and arrows of outraged readers.

Alembic

I.C.I.'s £180 MILLION BID FOR COURTAULDS

The prize is Britain's man-made fibre trade, one of the world's fastest growing industries

EXCEPTIONALLY high growth rate in man-made fibres with the market likely to expand at an estimated 10-12% compound increase per year for several years, is the reason behind I.C.I.'s approach to Courtaulds Ltd. for merger talks in September. I.C.I.'s offer for Courtaulds, worth £180 million, was disclosed by chairman, Mr. Stanley Paul Chambers, on Monday following strong rumours and reports in the Press the same morning.

The offer had been made to Courtaulds only three days earlier and there had been no intention of making any announcement until the directors of Courtaulds had considered the terms. Once the rumours had started—and a man posing as a representative of the I.C.I. London Press office had telephoned many national newspapers on Sunday with details of the merger—Mr. Chambers decided that it was in stockholders' best interests to make a public statement.

If accepted by Courtaulds, the offer, which was formally made only last Friday, would make I.C.I. the world's second largest chemical giant with 1960-61 sales of £730 million, combined assets of £902 million and pre-tax profits of £106.7 million.

Share exchange terms

The terms are the purchase of the entire ordinary and preference stock of Courtaulds on the following basis: For every £4 ordinary stock of Courtaulds, £3 ordinary stock of I.C.I., and for every £1 of 5% preference stock of Courtaulds, £1 of 5% I.C.I. preference, and for every £5 of 6% preference, £6 of 5% I.C.I. preference. This offer is subject to I.C.I.'s stockholders approving the necessary increase in capital.

All stockholders would be entitled to dividends declared by Courtaulds in the year ending 31 March 1962 and to all I.C.I. dividends for 1962. I.C.I. expect to declare the same total ordinary dividend for 1961 as for 1960 namely 13½%, and not less than that for 1962.

At his Press conference on Monday, Mr. Chambers declared that by far the biggest advantage of the merger would lie in man-made fibres, where the duplication of effort by British producers is seen to have a hampering effect both on the development of U.K. trade in synthetics as well as on the textile industry in general. Such a merger would be able to meet the two main fibre giants—Du Pont in the U.S. and Rhone-Poulenc/Rhodioceta on the Continent—on level terms as a fully integrated unit.

An I.C.I.-Courtaulds merger would place between 90% and 95% of all U.K. man-made fibre production and 25% of

paint production in the hands of the one organisation. The duplication of effort by the three main companies, I.C.I., Courtaulds and their joint company, British Nylon Spinners, compares most unfavourably with conditions in the U.S. and on the Continent where fully integrated producers cover the whole range of man-made fibres, said Mr. Chambers.

There is no intention of making Courtaulds a division of I.C.I., to lose the traditions and world-wide reputation of the name of Courtaulds would be the height of commercial folly, declared Mr. Chambers. British Nylon Spinners would, however, probably lose their separate name. All the man-made fibre interests of the three companies would be thoroughly

Four big advantages, says Mr. Chambers—prices, quality, new fibres and profits

THE biggest advantages of full integration were summarised by Mr. Chambers as:

- (1) Lower prices.
- (2) Improved quality.
- (3) Development of new fibres.
- (4) Improved profits.

The total combined labour force would be around 140,000.

The fibre interests of an integrated group would be greater than those of Rhone-Poulenc/Rhodioceta, but smaller than the synthetic fibre interests of Du Pont. The fibre trade would represent around 25% of I.C.I.-Courtaulds combined turnover, or some £180 million.

Cutting out duplication and wasted research effort

Clearly one of the biggest advantages envisaged by Mr. Chambers is the savings in research costs. On Monday he spoke of much wasted effort and duplication by the three U.K. companies, all doing similar work on man-made fibres. A merger would mean a much smaller total research staff on man-made fibres; but Mr. Chambers was quick to point out that there would be no redundancy of scientists. There is a great shortage of chemists, physicists and engineers throughout I.C.I. and men no longer required on fibre research would quickly be absorbed elsewhere.

Production and marketing costs would also be lowered and there would be a saving in capital spending. As a result Britain's competitiveness in world markets would be greatly strengthened. Mr. Chambers pointed out that Sir John Hanbury Williams, Courtaulds' chairman, had agreed with him that whether or

reorganised and integrated to take full advantage of the merger.

Unlike some recent mergers, the acquisition was not contemplated for the sake of closing down some production units—the object was one of expansion and no closures were contemplated. Integration would mean some redundancy, but this would probably be covered by all round group development and by natural wastage.

Both I.C.I. and Courtaulds plan nylon-6 plants in the U.K., and Mr. Chambers told "Chemical Age" that since (through the medium of the jointly owned B.N.S.) these plants had been agreed before the start of merger discussions, they would continue. This would give them a combined nylon-6 production total of around 20,000 tons.

not Britain eventually joined the Common Market, the building of a stronger U.K. man-made fibre industry would be essential. In fact, if Britain did not join the C.M., it would be more than ever important that this industry was strong enough to withstand Continental competition.

The merger would help avoid the big bugbear of the chemical industry—excessive capital tied up in plant which was not yet required. Such overcapacity waiting for markets to develop added tremendously to overheads. Apart from what he described as the saving of a very considerable amount of expenditure, Mr. Chambers said that integration in U.K. man-made fibre production would give powerful assistance to the British textile industry to enable it to keep on top of overseas competitors.

Workers overcome by sulphur chloride fumes

Five men were overcome by sulphur chloride fumes after an explosion at the I.C.I. Castner-Kellner works, Runcorn, on 13 December. After treatment they were allowed home. The accident was caused by water leaking into the sulphur chloride and causing white acid mist to escape.

R.S.A. lecture on British drugs

A lecture on 'Modern British Drugs' will be delivered by Frank Hartley, F.R.S., F.P.S., Director of Research, British Drug Houses, at the Royal Society of Arts, John Adam Street, London W.C.2, on 10 January at 2.30.

I.C.I.—Courtaulds merger

COMBINE WOULD BE WORLD'S SECOND LARGEST IN CHEMICALS

IF Courtaulds decide to accept I.C.I.'s offer, the resulting company will be the world's second largest chemical company. The largest chemical company of all, E.I. Du Pont de Nemours, realised net sales of £770 million in 1960. The combined sales of I.C.I. and Courtaulds for the year 1960-61 were £730.3 million (£558.4 million I.C.I. and £171.9 million Courtaulds), only £40 million below the U.S. company.

The merger of these two companies would bring into the same concern many subsidiaries with widely diverse interests.

Imperial Chemical Industries Ltd.

Amal Ltd.
British Nylon Spinners Ltd.*
British Titan Products Co. Ltd. *
British Visqueen Ltd.
Colling Explosives Ltd.
Cooke's Explosives Ltd.
Extended Surface Tubes Co. Ltd.*
I.C.I. Estates Ltd.
I.C.I. (Hyde) Ltd.
Ilford Ltd.*
Imperial Aluminium Co. Ltd.*
Imperial Chemical Industries (Export) Ltd.
Imperial Chemical Insurance Ltd.
Irvine Harbour Co.
Lightning Fasteners Ltd.*
Magadi Soda Co. Ltd.*
Marston Excelsior Ltd.
Plant Protection Ltd.
Richardsons Fertilisers Ltd.*
Robinson Plastics Films Ltd.*
Scottish Agricultural Industries Ltd.*
Settle Limes Ltd.
Slateite & Porcelain Products Ltd.
Thames House Estate Ltd.*
Ulster Fertilisers Ltd.*
Withing Paper Staining Co. Ltd.
Yorkshire Imperial Metals Ltd.*

Courtaulds Ltd.

British Celanese Ltd.
British Cellophane Ltd.
British Enka Ltd.
British Nylon Spinners Ltd.*
Cello Ltd.
National Plastics Ltd.
Pinchin, Johnson & Associates Ltd.
Styrene Co-Polymers Ltd.*
United Sulphuric Acid Corp. Ltd., The.*
* Associated companies.

Courtaulds and I.C.I. already have a common interest in British Nylon Spinners, and it is in the field of fibres that I.C.I.'s interest in Courtaulds chiefly lies, although the companies have other overlapping fields, mainly in paints, plastics films, olefins, sulphuric acid and other chemicals.

The following are estimates of U.K. production of non-cellulosic man-made fibres in 1962 and 1965:

	1960	1962	1965
	in '000 tonnes		
Nylon	29	34	53
Polyester	16	21	24
Other	3	12	20
All non cellulose	48	67	97

I.C.I. are currently the only producers of nylon, with capacity for some 30,000 tons of nylon-66. With their new nylon-6 plant and that of Courtaulds, and with expansion of nylon-66 facilities,

capacity by 1965 should total some 53,000 tons/year. Courtaulds are currently producing some 11,000 tons of acrylic fibres, due to rise to 16,000 tons shortly. Chemstrand are the only other producers of acrylic fibres, with 1962 capacity scheduled to rise to 11,000 tons. British Enkalon, who remain outside Courtaulds' recent take over of British Enka also

I.C.I.'s history is a series of mergers

THOUGH the names of both firms have long been household words, their development has been very different. Courtaulds have been 'Courtaulds' since they were established by Samuel Courtauld in 1816 and have expanded both in size and interests throughout the years by a series of acquisitions. I.C.I. on the other hand, were formed initially by the merger of four companies—Brunner, Mond and Co., Nobel Industries, United Alkali Co. and British Dyestuffs Corporation—already well established companies, and themselves the results of numerous mergers.

The story of the formation of I.C.I. in 1926, partly as a result of the circumstances of the time and partly of the foresight and determination of two men, Sir Harry McGowan and Sir Alfred Mond, illustrates a fact which is even more apparent today—that it is essential to expand and diversify to survive.

At the outbreak of the first world war, Britain depended on imports of Chile nitrate for the production of explosives, fertilisers and nitric acid, unlike Germany who had developed the Haber ammonia process. Moreover, she depended entirely upon Germany herself for many drugs, fine chemicals and dyestuffs. The war over, the determination that Britain should never again find herself so ill-equipped remained, and a gradual movement towards strengthening the industry through the consolidation of interests took place.

The four companies which formed I.C.I. were all highly efficient in their own specialised fields, but the formation of the great chemical combines of I.G. Farbenindustrie A.G. in Germany and Allied Chemicals and Du Pont's in the U.S. was making the leaders of the chemical industry in the U.K. feel that it was necessary to form an equally united front.

It was Sir Harry McGowan, chairman of Nobel Industries, who put forward the proposal that the four companies should merge. Sir Alfred Mond agreed to think it over. Only six months later negotiations were complete and I.C.I. came into being with an authorised

plan to enter the nylon-6 field with plant due on stream in Northern Ireland by 1963 with capacity for some 2,000 tons, to be doubled later.

I.C.I.—Courtaulds would also be able to give vast capacity of acetate, triacetate, polypropylene, polythene and protein fibres.

It is interesting to note the different part fibres that have played in the development of the two companies. Courtaulds started to make chemicals to ensure supplies for their artificial fibre plants. I.C.I. made fibre chemicals as part of the diversification of their chemical interests. Both companies are licensed to make caprolactam and nylon-6 and both are going ahead with their plans to do so.

capital of £64 million. I.C.I.'s present capital is £695 million.

The beginning of Courtaulds was small indeed. They began when Samuel Courtauld set up his own silk factory at Bocking in Essex and was later joined by his two brothers and a brother-in-law. In 1891, the partnership became a private company under the name of Samuel Courtauld and Co. Ltd. and a public company in 1904. Further reorganisation in 1913 gave Courtaulds their present title.

From the production of silk, Courtaulds considered the various attempts to make what was then called artificial silk. They bought the British patent rights of a process for the production of yarn from viscose, and a new factory began production at Coventry in 1905. This was the first commercially successful venture in the world to make viscose rayon.

In the middle 1930's Courtaulds turned their attention to the development of staple fibre from regenerated protein. In 1940, British Nylon Spinners were formed jointly by Courtaulds and I.C.I. and the first British nylon yarn was spun at Coventry in 1941.

Courtaulds began the manufacture of their own chemicals in 1916 with the operation of plants for the production of sulphuric acid and carbon disulphide, both important chemicals in the viscose process. Acetate manufacture also involved Courtaulds in the production of petrochemicals such as acetic anhydride and, following the acquisition of British Celanese in 1957 which included a petroleum cracking plant, the production of petrochemicals has steadily expanded. The bulk of Courtaulds and Celanese chemicals are consumed by the group, but increasing quantities are being made and sold outside.

The Group's knowledge of colours, pigments and dyes, together with the fact that they manufactured the chemicals necessary for paint production, led naturally to their interest in the paint industry. Cello Ltd., was acquired in 1958, followed in 1960 by the acquisition of Pinchin, Johnson and Associates Ltd., one of the largest paint manufacturers in Europe.

N.R.D.C. annual report

U.K. chemical firms show no interest in new acetylene route

THE National Research Development Corporation have discontinued expenditure on the process for the production of acetylene by the partial combustion of methane. This was announced last week by the N.R.D.C. managing director, Mr. J. C. Duckworth, when he introduced the twelfth annual report.

The process for the production of acetylene was originally developed at Imperial College in 1951. In 1958 it was transferred to a small laboratory set up by the Corporation at Mogden Drainage works of the Middlesex County Council where continuous supplies of methane were available.

The reason for discontinuing expenditure on this project is that all the development work that can be done without further scaling up being completed and the point has been reached at which the co-operation of a commercial concern is essential.

Disappointing response

Response to the process from industry has been a little disappointing; there has been a swing in acetylene production towards the ethylene route, and it appears that the 10% increased yield that the methane route gives is not sufficient to induce manufacturers to undertake considerable capital outlay for new plant. They say that a 25% increase in yield would be necessary to make it worth while.

The N.R.D.C. had hoped that some U.S. firms would be prepared to co-operate on the project but negotiations have not been successful. Negotiations are still in progress, however, with a European company, who already have methane processing equipment installed.

The response in the U.K. is perhaps what might have been anticipated. Several firms would be interested in keeping the process in cold storage against the time when Saharan methane becomes available in this country, but do not see their way to spending money on scaling up the process before then. One firm, however, has co-operated with the N.R.D.C. and the Department of Scientific and Industrial Research in the operation of a pilot plant. Raw material would be supplied by the Gas Council. It is understood that the price has been brought down to 6d a therm from 10d a therm quoted last year. Under this scheme the Gas Council would probably buy back usable gases.

The N.R.D.C. spent a record sum on the backing of U.K. inventions last year. The annual report discloses that the expenditure on development during the year to 30 June 1961 was £812,000, compared with the previous highest figure of £592,000 in 1959. Forward

commitments, including those of the Corporation's subsidiary development companies, amounted to £1,150,000. Recoveries of development expenditure through patent agreements and royalties amounted to £47,000. Mr. Duckworth said that he thought the Corporation could play an important part in encouraging co-operation in development projects which may be too large even for major companies, but they would need to be very skilful in selecting in advance those fields which are likely to be of future importance. It is the intention of the N.R.D.C. to endeavour to set up joint enterprises in new fields of activity wherever possible and appropriate.

Several major projects, including fuel cells, took promising steps towards the eventual goal of large-scale commercial application. Three major British companies in the engineering field have agreed to co-operate in the development work. The development of fuel cells is still very much a process of hit and miss, albeit an inspired one, and a great deal more money will need to be spent.

In Parliament

Labour M.P. says Minister's remarks on pyrethrum could harm industry

THE Parliamentary Secretary to the Ministry of Agriculture, Mr. W. M. F. Vane, elaborated further on his comment made in the House of Commons last month (see C.A., 18 Nov., p. 818) that pyrethrum was among the less effective substances, when Mrs. J. Butler (Lab., Wood Green) asked him in the House last week if he would say something to remedy the effect of his remarks. Mrs. Butler pointed out that these remarks, widely reported, might do great harm to the pyrethrum industry.

Mr. Vane did not think that the previous remarks he had made need have done any harm, because every one knew that pyrethrum was a potent insecticide with a rapid paralysing action and highly toxic to a wide range of insects. It was also of low mammalian toxicity and safe to use on foodstuffs and in the house. One of the difficulties, however, was that it was not so persistent as some other insecticides, and therefore could be at a disadvantage in that regard for certain uses.

The exchange between Mr. Vane and Mrs. Butler followed a question by the latter as to what research had been undertaken by the Ministry of Agriculture into the effectiveness of pyrethrum as a pesticide, to which Mr. Vane replied that fundamental research of this type

May and Baker develop new sulphonamide

A NEW sulphonamide, discovered and developed in the research laboratories of May and Baker Ltd. is to go into production at the company's Norwich works. Called Bidizole (sulphasomizole), the new drug is a long (but not ultra long) acting sulphonamide which can be used in all conditions for which sulphonamides are applicable, either alone or in combination with penicillin or other antibiotics. Bidizole is remarkably well tolerated and has no unpleasant side effects. The discovery of Bidizole comes 24 years after that of the well-known M & B 693.

May and Baker are undertaking a considerable expansion at Norwich; the cost of the development at present stands at around £2.5 million. Some of the industrial chemicals production has been moved there from Dagenham.

Polarographic Society lecture

A lecture on 'Polarography of Carbon dioxide' will be given by Prof. J. Jordan of the Pennsylvania State University, at present at the Laboratorium für Anorganische Chemie Eidgenössische Hochschule, Zurich. He will address a meeting of the Polarographic Society to be held on 18 January 1962, at the Biochemical Department, Institute for Diseases of the Chest, London S.W.3, at 5 p.m.

was the responsibility of the Minister for Science. Research had been in progress for many years at Rothamsted Experimental Station and the Pest Infestation Laboratory of the Agricultural Research Council and recently, also, at the Tropical Products Institute of the D.S.I.R. The Ministry was being kept in close touch with this work, he added.

No plans for compulsory pesticides scheme

There were no plans at present for making notification compulsory in connection with the Notification of Pesticides Scheme and the Agricultural Chemicals Approval Scheme, Mr. Soames, Minister of Agriculture, Fisheries and Food, said in a written reply to a question. Mr. Soames said the Government accepted the view of the Research Study Group on Toxic Chemicals in Agriculture and Food Storage (C.A., 9 December, p. 918) which confirms that the arrangements made between Government and industry have been generally successful in ensuring the safe use of pesticides. These arrangements, which were kept under constant review, were based on the principle of voluntary co-operation. The Government wished to keep to this sort of arrangement when it was working satisfactorily in both schemes.

I.C.I. streamline research and development facilities, set up new petrochemical laboratory

A NEW laboratory is to be created by I.C.I. in order to increase exploratory research in the high polymer and petrochemicals field. In addition, the head office research and development departments are to be merged and the head office technical department strengthened. These changes will take effect from 1 January.

Dr. D. S. Davies, research director, General Chemicals Division, who has been appointed head of the laboratory



L. S. Mumford

Dr. H. G. Reid

from 1 January, will also for the present be head of the amalgamated research and development department. **Mr. M. A. T. Rogers** will be assistant head of that department.

Mr. R. B. Richards, research director of the Heavy Organic Chemical Division, will succeed Dr. Davies at General Chemicals Division, and **Mr. M. A. E. Hodgson**, H.O.C. Division development director, will become division research director. **Dr. J. W. Woolcock** will succeed Mr. Hodgson as H.O.C. Division development director, in addition to his present duties as techno-commercial director.

With the formation of the new research and development department at head office, the offices of development controller and research controller will be discontinued. The reorganised technical department will give increased attention to the company's expansion and long-term development, in addition to carrying out its present duties for which **Dr. A. C. Hutchinson** will remain responsible.

Mr. W. A. M. Edwards, I.C.I. purchases controller, who will head the tech-

nical department, will be succeeded by **Dr. H. G. Reid**, at present chairman and president of I.C.I. (New York) Ltd. Dr. Reid, who for a brief spell was first general manager of the Severnside Works, will take up his new duties at a date to be arranged.

Mr. L. S. Mumford, whose post as development controller is discontinued,

will undertake special investigations of a techno-economic nature for the I.C.I. technical director, assisted by an appropriate staff. The heads of the technical and central work study departments, the engineering controller and Mr. Mumford will each be responsible to the technical director, in whose absence Mr. Edwards will act in respect of these departments.

Mr. W. Reid has been appointed a visiting director of the European Council in succession to **Mr. M. G. Davies**. As already announced **Mr. P. C. Allen** relinquishes the presidency of Canadian Industries Ltd. on 1 March and will take over as overseas director (West Europe) from **Dr. A. Caress**, who is also research and development director.

BRADFORD MEETING ON NEWER DRUGS

ANTIBIOTICS and newer drugs will be the subject of the 1962 symposium organised by the Bradford Chemical Society and the Department of Chemical Technology, Bradford Institute of Technology in conjunction with the Yorkshire Council for Further Education.

A strong team of speakers will give papers as follows: **F. A. Robinson** (Crookes Laboratories Ltd.) on 'The newer antibiotics'; **F. P. Doyle** (Beecham Research Laboratories Ltd.) on 'Recent

advances in the chemistry of penicillin'; **A. Webb** (A. Wander Ltd.) on 'Anti-tuberculous drugs'; and **Dr. V. Petrov** (British Drug Houses Ltd.) on 'Some new biologically active steroidal materials'.

Dr. W. Cule Davies, chairman of the chemistry advisory committee, Yorkshire Council for Further Education, will preside. Venue will be the Bradford Institute of Technology, Great Horton Road, Bradford 7 and the symposium will be held on Saturday, 10 February, starting at 9.30 a.m.

Sales, work done, topped £2,000 m. in 1960

THE value of sales and work done in the U.K. chemical and allied industry (excluding oil refining and paint and printing ink) in 1960 topped the £2,000 million mark and showed a 6.7% rise over 1959. The actual total was £2,061,800,000, a rise of £131 million over the previous year. This compared with a 10% rise for all manufacturing industries.

These figures are revealed in the 1960 report of the Census of Production.

Sales and work done includes all sales,

plus any new building work, machinery or other capital items produced by a business for its own use. As far as possible, the value of goods transferred from one unit to another within the same business is excluded.

Fixed capital spending in the chemicals and allied industries (other than refining and paint) in 1960 totalled £136.1 million, a rise of £10 million of 1959.

The following is an extract from the census report, published in the *Board of Trade Journal*, 15 December.

FIXED CAPITAL EXPENDITURE (IN '000 TONS)

	Total (net)	New building work	Vehicles		Plant, machinery, etc.		
			Acquired	Disposed	Acquired	Disposed	Disposed
All industries	1958 921.6 1959 863.5 1960 1,028.2	246.6 219.6 267.9	75.5 82.5 102.8	23.2 27.5 32.2	649.0 608.6 712.5	26.3 19.7 22.8	
Oil refining	1958 39.7 1959 23.4 1960 15.3	7.2 3.4 3.8	0.4 0.2 0.2	— 0.1 0.1	32.2 20.1 11.5	0.1 0.3 0.2	
Paint & printing ink	1958 6.3 1959 5.7 1960 5.2	2.4 2.0 1.8	1.5 1.7 1.7	0.6 0.7 0.7	3.0 2.8 2.6	0.1 0.1 0.1	
Other chemical & allied industries	1958 151.0 1959 135.1 1960 136.1	34.5 27.4 36.6	7.6 7.5 8.8	2.3 2.5 2.9	113.7 104.3 95.2	2.5 1.5 1.6	

SALES, STOCKS AND WORK IN PROGRESS (IN '000 TONS)

(Estimates for all Firms in the U.K.)

Industry groups	Sales and work done		Stocks and work in progress											
	1959	1960	Total		Goods on hand for sale		Work in progress		Materials, stores and fuel					
			End of 1959	Changes during year 1959-1960	End of 1959	Changes during year 1959-1960	End of 1959	Changes during year 1959-1960	End of 1959	Changes during year 1959-1960				
All manufacturing industries	22,261	24,551	5,048	+137	+598	1,243	+19	+189	1,825	+72	+169	1,980	+46	+240
Mineral oil refining	378.5	468.8	97.4	+5.1	-1.4	38.9	+5.0	-4.6	11.4	+1.9	-0.9	47.1	-1.9	+4.1
Paint and printing ink	180.5	184.2	32.4	+2.1	+3.2	16.8	+1.0	+1.8	2.1	+0.1	+0.2	13.5	+1.0	+1.2
Other chemical and allied industries	1,930.8	2,061.8	318.0	+18.0	+38.4	153.2	+12.1	+24.6	29.8	+3.0	+1.6	135.1	+3.0	+12.2

Centrifuge dewateres sludge at Albright phosphorus works

THE question of the disposal of solids is one which concerns many sectors of the chemical industry. The problem as it is met with in the production of elemental phosphorus, was discussed by M. E. Chodak, Albright and Wilson (Mfg.) Ltd., Oldbury, in a paper given at the symposium on the treatment of industrial and sewage sludges held by the Institute of Sewage Purification on 20 December.

At the Albright and Wilson phosphorus plant at Portishead, the phosphorus is condensed from the furnace gas with water, some of which is taken away from the system. This effluent contains various oxyacids, soluble fluorides and silico-fluorides, unreacted phosphate dust and other suspended solids, such as free silica and anthracite. It is now produced at the rate of some 20,000 gall. per hour, and the problem is to neutralise the acids and to separate the suspended solids from the effluent before discharging into the sea.

A treatment plant was installed and commissioned in 1954, comprising a milk of lime preparation section, three lime reaction tanks, a thickener and a rotary vacuum filter. An automatic pH recorder-controller was also installed. For six months after the adoption of the pH control, the thickener worked well but gradually its performance became variable and difficulties were encountered in the operation of the vacuum filter.

It was recognised that there were two essential requirements for the satisfactory operation of the thickener: the settling rate of the suspended solids must exceed the overflow rate by a sufficient margin; and the precipitated sludge must be continuously withdrawn at such a rate as to keep the thickener in balance—i.e. the filtering must be efficient. The first condition appeared to be generally satisfied but the vacuum filter could not possibly cope with the load of solids arriving at the plant. A choice had to be made between increasing the filtering capacity by installing an additional filter or considering methods other than filtration for dewatering the slurry. Since a very considerable increase in the filter area would have been necessary at high capital cost, it was decided to investigate the feasibility of centrifuging the slurry.

After preliminary trials, the centrifuge selected was a P-300 Super-D-Canter, capable of treating up to 1,200 gall. per hour thickener underflow.

The effluent arrives at the plant at a rate varying between 10,000 to 20,000 gall. per hour. It passes, after metering, to the first reaction tank where it meets the outflow from the centrifuge, is stirred and overflows to the second reaction tank. Here automatic addition of lime takes place. The limed effluent is stirred and allowed to overflow into the third reaction tank in which a pH measuring head is situated. After stirring, it passes to the thickener via the junction box

which serves to trap any foreign bodies that might accidentally fall into the tank.

The overflow from the thickener is discharged into the sea. One or two mono-pumps continuously move the sludge from the bottom of the thickener and feed the centrifuge. The centrifuge outflow is recycled back to the first reaction tank and the solids are discharged by gravity to a hopper underneath the centrifuge.

There can be no doubt, the author concludes, that the centrifuge is now a

proved unit for dewatering sludges derived from the plant manufacturing elemental phosphorus. As well as being economically attractive, its application is providing an answer to current problems of production and disposal of solids.

Other papers read at the symposium included: 'Disposal of solids in the paper industry', by T. Waldemeyer (Water and Effluent Chemical Engineer, Reed Paper Group); 'Disposal of sludges on land', by A. R. Stone (Manager, City of Nottingham Sewage Works and Farms); 'Anaerobic digestion of sewage sludge', by S. G. Burgess (Scientific Adviser, London County Council); and 'Some recent investigations concerning dewatering of sewage sludges', by K. J. White and Marion F. Davidson (Water Pollution Research Laboratory).

World consumption of synthetic rubber expected to overtake natural in 1962

SYNTHETIC rubber consumption is expected to overtake that of natural rubber in 1962, according to estimates made by the management committee of the International Rubber Study Group. Estimates in long tons of natural and synthetic production and consumption are given in the following table.

Further sales from Government stockpiles are expected but it is not yet possible to estimate their size. Deliveries from Government stock during 1961 are estimated at about 32,000 tons.

World Consumption and Production of Rubber

	1961	1962
Natural rubber		
consumption	2,050,000	2,040,000
production	2,018,000	2,062,500
Synthetic rubber		
consumption	1,870,000*	2,075,000
production	1,940,000*	2,135,000*

* excluding synthetic rubber produced in non-member countries.

Territory	Rubber Consumption in 1961		Total
	Natural	Synthetic	
U.S.	424	1,076	1,500
U.K.	168	115	283
Japan	165	90	255
West Germany	135	115	250
France	130	90	220
Italy	77	58	135
Canada	30	57	87
Czechoslovakia	53	7*	60
India	50	10	60
Australia	35	21	56
Netherlands	20	14	34
Belgium†	15	12	27
Austria	11	11	22
Indonesia	18	—	18
Denmark	6	3	9
Hungary	8	0*	8
Malaya and Singapore	8	—	8
Other member countries‡	6	—	6
Other countries	691	191	882
	2,050	1,870	3,920

Rubber Production in Member Countries in 1961

U.S.	1,365
Canada	162
U.K.	100
Italy	87
West Germany	85
Other member countries	141
	1,940

* Consumption data for synthetic rubber exclude synthetic rubber produced in non-member countries.

† Including an allowance for Luxembourg.

‡ Comprising Burma, Cambodia, Ceylon, Liberia, Nigeria, Thailand, and Vietnam.

Note: The oil-content of oil-extended rubbers is included in the figures.

D.S.I.R. booklet describes ultrasonics uses

EMULSIFICATION, dispersion, and the degassing of liquids are among applications of ultrasonic techniques described in a new illustrated booklet, 'Using ultrasonics', produced by the Department of Scientific and Industrial Research, State House, High Holborn, London W.C.1. Other applications discussed include viscosity measurement, flow measurement, and non-destructive testing.

Revised edition of Poisons and T.S.A. Guide

The 1961 revision of the sixth edition of the Poisons and T.S.A. Guide is available at 7s 6d. In this edition the information has been extended to include the requirements of the Dangerous Drugs Act, 1951, the regulations made under the Act, and the Therapeutic Substances Act, 1956, as far as it concerns the dispensing and supply of anti-tubercular substances and other therapeutic substances controlled by that legislation.

Petrochemical story well told in Distillers' new film

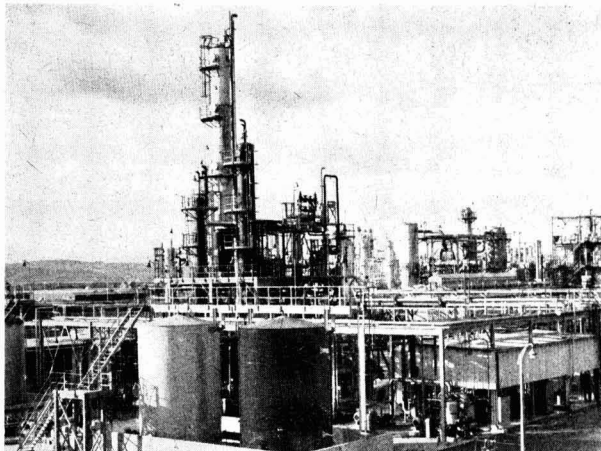

Group of petrochemical plants at British Hydrocarbon Chemicals' £35 million Grangemouth works. In the foreground—the synthetic methanol unit, completed in October

THE story of the production and utilisation of petrochemicals is well told in a new colour film with the title 'The Double Bond', which was given a preview in London last week by The Distillers Co. Ltd. Essentially non-technical in its approach, the film should have a wide appeal to audiences interested in British industrial and scientific matters and would also make an excellent 'curtain raiser' for more specialised films on plastics, solvents and other detailed aspects of the industry. A welcome feature in a film of this sort is that the material is presented impartially, company names

being almost completely excluded.

The story begins with the unloading of crude petroleum oil at Loch Finnart, Scotland, and its transfer by pipeline to the Grangemouth works of British Hydrocarbon Chemicals Ltd. (owned jointly by Distillers and the British Petroleum Co. Ltd. The fundamental process of 'cracking' and the conversion of the resulting olefins to ethyl alcohol, phenol, styrene and other compounds, including polythene, are shown diagrammatically and also in sequences taken in the actual production units.

The utilisation of these compounds in the works of the D.C.L. Chemical Division is indicated, together with their conversion into polystyrene, p.v.c. and other plastics materials by the Distillers Plastics Group, and the fabrication of finished products by units of the British Xylonite Group.

The film includes some descriptions of the testing and quality control involved, and concludes with an animated sequence suggesting some of the possible future developments for petroleum chemicals.

The film, made for D.C.L. by Greenpark Products Ltd. in association with the Film Producers Guild, is on 35 mm. and 16 mm., in colour, with optical sound, and has a running time of 28 minutes.

A.E.A. contract for Nottingham University

The newly established Department of Chemical Engineering at Nottingham University has received a research contract from the U.K. Atomic Energy Authority. Professor R. E. Johnstone, head of the department, was formerly employed with the A.E.A.

Du Pont fibre offers economies as packing for pumps, valves

PROMISE as a new, economical braided packing for pumps and valves handling corrosive fluids is shown by an improved Teflon t.f.e. fluorocarbon fibre, specifically developed for this purpose and now made available commercially by Du Pont de Nemours International S.A., 81 Route de l'Aire, Geneva, Switzerland.

The new bleached fibre has been tested extensively by several companies and these tests are claimed to show that the new packing material is much less sensitive to the effects of operational and frictional heat, and more receptive to gland adjustment than the earlier fibre. This results in greatly improved service life, particularly in high-speed rotary pumps, and reduces markedly the need for special installation and break-in techniques.

Improved performance is attributed to the complete removal of all carbonaceous material from the Teflon t.f.e. fibre by bleaching and pre-shrinking the fibre (580° F for 32 hr.) before braiding. Removal of carbon eliminates the sources of exothermic heat resulting from oxidation of the carbon, and reduces the packing's tendency to 'burn.' Pre-shrinking of the yarn before braiding results in greater dimensional stability at elevated temperatures, reducing the packing's tendency to change dimensions in service.

Properties of the new packing material—resistance to flow, self-lubrication, chemical inertness, and a wide operating temperature range—offer a number of advantages. Packings require a shorter run-in time and only occasionally a few gland adjustments are required.

M. & B.'s new range of volumetric solutions

A NEW range of standard volumetric solutions made up, accurately standardised and ready for immediate use is available from May and Baker Ltd., Dagenham. Known as Volusol solutions they can be used as alternatives to Volucon standard volumetric concentrates, where large quantities of volumetric solutions are used and there is a shortage of time or skilled staff.

Volusol solutions are available in 2½ l. glass bottles, except for standard alkalis which are marketed in 4½ l. non-returnable plastics containers. The range comprises the solutions most commonly used in analytical control laboratories.

Plant & Maintenance Exhibition at Alexandra Palace

An International Plant and Maintenance Engineering Conference and Exhibition is being organised to take place at the Alexandra Palace, North London, 17-21 June, 1963, following the success of the First National Maintenance Conference and Exhibition held recently at the Central Hall, London. A symposium and exhibition on industrial process heating is also being organised.



Part of the process flow indicator and recorder panels of Grange Chemicals' detergent alkylate plant at Grangemouth

Overseas News

LPG TANKER CARRIES 50,000 BARRELS ON MAIDEN VOYAGE

THE first tanker to be specially designed to carry LPG recently left the Ras Tanura, Saudi Arabia, plant of the Arabian American Oil Co. for Japan with a cargo of 50,000 barrels of butane and propane. The new Arabian plant is the first-ever to be designed to refrigerate LPG for tanker shipment. The 46,000-ton tanker—the *Gohshumaru*—is carrying 30,000 barrels of refrigerated propane and 20,000 barrels of refrigerated butane in five insulated tanks each with a capacity of 10,000 barrels.

The gases were pumped under pressure from the refinery to the refrigerated plant at the Ras Tanura terminal area. Here propane was cooled by evaporation and butane by heat exchange. The LPG shore installation comprises three 80,000-barrel tanks, insulated tanks in which the gases are stored under pressure of about 1½ p.s.i.

The tanker can carry 250,000 barrels of crude oil in tanks on either side of the LPG. The gases are destined for the General Gas Co., Kawasaki.

Montecatini negotiate Indian expansion in TiO₂

Dr. Taramasso, resident representative of Montecatini, has been discussing with Mr. K. A. Damodara Menon, Minister for Industries, a proposal for expanding production in the Travancore Titanium Factory at Trivandrum, in which the State Government holds the majority of shares.

U.S. synthetic detergent sales rise by 3.5%

In the first nine months of this year, U.S. sales of synthetic detergents rose 3.5% to more than 2,600 million lb. According to the Association of American Soap and Glycerine Producers, biggest gains were recorded by liquid materials—up 11.7% to 530 million lb.; sales of solid produce rose 1.5% to more than 2,000 million lb. Sales of soaps declined from 805,300,000 lb. in the first nine months of last year to 771,500,000 lb. in the same period of 1961.

Construction to start soon on Esso Nederland aromatics plant

Construction is to start 'very soon' of the aromatics plant planned to be built on the site of the Esso Nederland oil refinery in Rotterdam, initial details of which were announced in CHEMICAL AGE 15 April, p. 617; preliminary work has now been completed. Permission for erection has still to be given by the Netherlands Government. It will cost some Fl.65 million and it is hoped to start production at the end of 1963. Initial output will be of 220,000 tonnes annually, the production programme covering benzole, toluene o-xylene, m-

xylene, p-xylene and xylene compounds. Most of the plant's output—its start will make Esso the world's largest aromatics producer—will be exported, it is stated.

Japan's rising demand for carbon black

The Carbon Black Association of Japan has forecast that the country's carbon black demand for 1962 will be 60,000 tonnes, a 29% increase over 1961. It is estimated that domestic production will be about 40,000 tonnes.

Reorganisation of CIBA's U.S. interests

UNDER a reorganisation of CIBA's U.S. interests, Dr. Robert Käppeli and Dr. Victor Umbricht will serve as chairman and president respectively, of the new CIBA Corporation, with effect from 1 January. On the same date all CIBA companies will be merged into CIBA Corporation. These companies include CIBA Pharmaceutical Co., Summit, N.J., CIBA Chemical and Dye Company, Fair Lawn, N.J., and CIBA Products Co., Fair Lawn, N.J.

The board of the CIBA Corporation will have the same members as the previous organisation, CIBA States Ltd., except for the retirement of the former chairman, Mr. Frank Common, and the election of Dr. Albert Wettstein.

Other officers of the corporation are T. F. Davies Haines, executive vice president, David B. Dyche, vice president in charge of finance, Dr. Harry B. Marshall, vice president, Roderic L. O'Connor, vice president and secretary, Clifton S. Thomson, general counsel, Karl Zimmermann, controller, and T. H. Saari, treasurer. Present operating subsidiaries become divisions of the CIBA corporation. Mr. Haines will continue as president of CIBA Pharmaceutical Company, Dr. Marshall will continue as president of CIBA Chemical and Dye Co., and Donald Joseph will become president of CIBA Products Co.

Geneva law-suits name Robert S. Aries

Mr. Robert S. Aries, who has been named in a number of suits pending in U.S. courts on grounds of illegal acquisi-

Italy's mounting investments in petrochemical industry

During 1960, several petrochemical schemes were launched in Italy and by the end of the current year, these schemes will bring investments in this sector to about 168,000 million lire. During 1962, this figure will be increased to little less than 250,000 million lire.

At the same time, the total output of the Italian petrochemical industry (expressed in terms of carbon content) will increase from 270,000 tonnes in 1960 to 500,000 tonnes in 1962.

The major schemes that are being carried out under this heading are: Montecatini at Brindisi to be ready at 1962), A.N.I.C. at Gela, three schemes at Ferrandina (A.N.I.C., Montecatini and Ceramica Pozzi) and several minor ones in various parts of Italy.

Celene plan ethylene amines plant in Sicily

Celene (owned by Union Carbide and Edison) are to build plant at Priolo, Sicily, with an initial capacity of 16 million lb./year of ethylene diamine and related products. The unit is due on stream by early-1963.

tion of trade secrets, has now also been named in suits filed in Geneva by Merck and Co. and Hoffmann-La Roche. Charges are similar to those laid in the U.S. Mr. Aries is charged with selling to Hoffmann-La Roche an option on Amprol, amprolium, a drug developed to combat coccidiosis in poultry.

In the U.S. Rohm and Haas, claim that Mr. Aries illegally received secret information about a polymeric oil additive, while Celanese Corporation are asking for \$206,000 damages on grounds that Mr. Aries failed to deliver data on an acetate gasoline additive for which he was paid \$6,000.

New corp. will make Lederle drugs in Australia

A joint corporation with total assets of approximately \$3 million, is to be formed by American Cyanamid Co. and Drug Houses of Australia Ltd., who have been the distributors and later the licensees for Cyanamid's Lederle Laboratories Division for more than 12 years.

The new company will manufacture and sell Lederle brand pharmaceuticals. A plant to produce broad spectrum antibiotics is to be built at Laverton, Melbourne, and is expected to be in production by the end of 1962.

The plant will produce a variety of drugs including Aureomycin, Achromycin, Declomycin, and also Aureomycin for use in animal feedstuffs. Cyanamid will continue to operate their surgical suture plant in Hurtsville through their affiliate, Cyanamid Australia Pty. Ltd.

Overseas news

NEW DU PONT HERBICIDE BASED ON COMPOUND FROM NEW CHEMICAL FAMILY

TWO new weedkiller compounds have been announced in Paris by Du Pont at an international symposium on weed control organised by the European Weed Research Council and the French Committee Against Weeds. They are Lorox, a herbicide for selective weed control in field corn and soybeans, and a compound temporarily designated Du Pont Herbicide 82. For non-crop use, the latter promises to be of particular value for weed control in sites where hard-to-kill weeds and grasses are a critical problem. Such sites include industrial areas, railroad and storage yards, roads and rail tracks.

Both products were developed by Du Pont research chemists and they will be commercial introduced in the U.S. in 1962. No date has been set for their introduction in Europe.

Herbicide 82 is based on one compound in a new family of chemicals designated as substituted uracils. Its chemical formula is 3-isopropyl-5-bromo-6-methyl uracil. Tests are claimed to have shown that it is two to five times more effective against hard-to-kill grasses than soil sterilants now in common use. As this new family of chemicals promises to provide interesting candidates for a variety of herbicidal applications, several other substituted uracil compounds have been developed by Du Pont and are currently being tested.

Lorox weedkiller is formulated as a 50% wettable powder to be mixed in water and applied as a spray. It is based on 3-(3,4-dichlorophenyl)-1-methoxy-1-methylurea. Du Pont have proposed that the term 'linuron' be established as the approved name for this product.

Hydrogen peroxide plant for Japan

Under construction by Edogawa Chemical Co., Osaka, is a 1,000 tonnes/month hydrogen peroxide using a self-developed autoxidation process. The plant is due on stream by March, 1962, and is an addition to an existing 900 tonnes/month capacity unit that is based on the electrolytic process.

U.S. firm introduces polypropylene carpet

First commercial production of a new carpet fibre and carpet, made from polypropylene, has been announced by E. T. Barwick Mills, Inc., Chamblee, Ga. The polypropylene resins and fibre were made by Hercules Powder at Covington, Va. and Lake Charles, La. The carpet will be tufted with Hercules polypropylene solution-dyed yarn, and priced at about \$7.95/sq. yd.

Hercules Imperial Color Chemical and

Paper Department, who make the colours, had to develop special techniques for dispersing the colours to make them satisfactory for use in spinning fibres.

More calcium carbide planned by Odda

Odda Smelteverk A/S, Norway, will over the next five years expand hydro-electric power facilities to enable calcium carbide output to be raised from 50,000 to 80,000 tonnes annually. Odda also produce calcium cyanamide and dicyandiamide.

Fall in Sicilian sulphur production

During the first nine months of 1961, production of sulphur in Sicily totalled 725,800 tonnes (15.1% down on the 854,800 tonnes total of last year). Output of molten sulphur fell 20.8% from 41,300 tonnes to 32,700 tonnes.

Production of wet flotation sulphur is reported to have risen 50.7% over the same period, reaching 39,800 tonnes.

1,200 tons/day sulphuric acid unit on stream

A 1,200 tons/day sulphuric acid plant has been commissioned by U.S. Phosphoric Division of the Tennessee Corporation at Tampa, Fla. Based on Frasch sulphur, the plant uses Monsanto know-how. Most of the output will be used by the company for its own fertiliser production.

Further price changes for U.S. chemicals

Dow Chemical and Monsanto Chemical have cut their prices of phenol from 16.25 to 14.5 cents/lb.

Dow Chemical have cancelled their recent 1 cent/lb. rise for polystyrene, bringing the price back to 18 cents/lb.

Allied Chemical are raising their nitrogen product prices by 2%, or by \$3/ton of nitrogen with effect from 1 January. The rise covers ammonia, ammonium nitrate, sodium nitrate, urea, ammonium sulphate and all related products.

Changes in Ceylonese import regulations

Licences are no longer needed in Ceylon for the import of ammonium sulphate produced in any territory other than the Ceylonised area. Similarly, licences are no longer needed for sulphur produced in any territory other than the Ceylonised area and the dollar area. Newly imposed import restrictions on caustic soda do not apply to goods in the hands of carriers or in course of shipment on 15 November; goods ordered against irrevocable letters of credit established before this date will also be allowed into Ceylon.

E.N.I. oil and fertiliser plants in Ceylon

Representatives of E.N.I. are negotiating in Colombo an agreement with the Government of Ceylon for the establishment of an oil refinery and a fertiliser plant. The two units would cost about \$50 million, half of which would be provided by E.N.I. and the other half raised locally. After a number of years, E.N.I. propose to withdraw from the venture, leaving operation of the two plants to Ceylonese interests.

Edison's new caustic/chlorine plant at Mantua

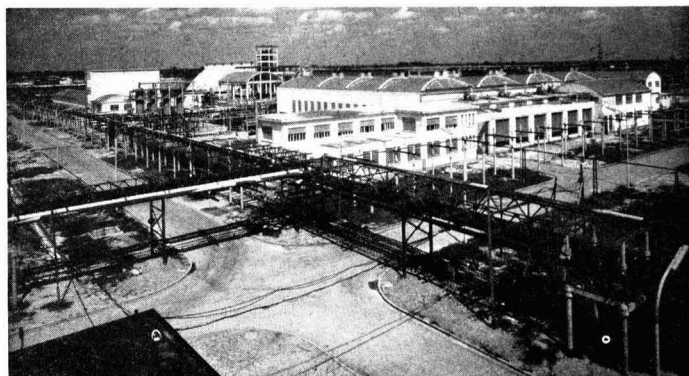

A recent view of the chlorine and caustic soda plant at Mantua of the Chemical Division, Soc. Edison

Bookshelf

POLYMER CHEMISTRY TEXT COVERS NEEDS FOR A.P.I.

A PRACTICAL COURSE IN POLYMER CHEMISTRY. By *S. H. Pinner*. Pergamon Press, London, 1961. Pp. xv+156. 25s.

This is the second recent text intended to cover requirements for the Associateship of the Plastics Institute; it will also be of value in courses where the organic chemistry and some aspects of the physical chemistry of polymers are taught. The distribution of experiments is: monomer preparation (4), polymer modification and degradation (8), polymerisation (16), polycondensation (3), viscometry (1), osmometry (2), analysis (5). There are very complete details on viscometry and osmometry procedures.

The general emphasis is on the organic preparative side; it would be helpful in a number of cases to characterise the different products more fully by specific physical examination, and to make the 'reports' more quantitative in character.

This volume has an almost entirely different content from the Experimental Plastics of Redfarn and Bedford which also emanated from the Borough Polytechnic, and which was concerned with the compounding, fabrication and testing of plastics.

► I.U.P.A.C. notation

RULES FOR I.U.P.A.C. NOTATION FOR ORGANIC COMPOUNDS. Longmans. Pp. 107. 25s.

This volume is issued by the I.U.P.A.C. Commission on the codification, ciphering and punched card techniques for organic compounds.

The Commission have based their notation on the well-known Dyson system but have considerably revised and extended it. The system, which is based fundamentally on chemical concepts, provides unique ciphers for all compounds of known structures including mesoionic and polymeric compounds: the cipher also specifies the stereochemistry. The notation is applicable to those structures for which systematic names cannot be made for existing rules. Only one structure can be constructed from a given cipher.

The notation is concise and gives a linear cipher which can be set on a typewriter or a printer's keyboard. It provides a reasonable degree of classification in indexing, and with its ultimate use in indexes and lexicons in mind, the symbols have been simplified so that ciphers can be directly punched in, for example, an I.B.M. card and the data recovered as originally written with the I.B.M. document-writing machine. The notation is also suitable for use in spoken form.

The 11 sections into which the book

is divided are entitled: symbols, acyclic hydrocarbons, substituted acyclic structures, aliphatic heterogeneous structures, carbocyclic compounds with one ring, ring aggregates, heterocyclic systems, assembly notation of cyclic compounds, compounds with elements other than C, H, O, N, S and halogen, stereoisomerism, and lastly abnormal valencies, salts, isotopes and persubstitution. There are four appendices which deal with the arrangement of ciphers in index form, deciphering, some examples of ciphering and finally, special examples. A comprehensive index is also provided.

► Cybernetics

AN APPROACH TO CYBERNETICS. By *G. Pask*. Hutchinson and Co. Ltd., 1961. Pp. 128. 12s 6d.

This is not an easy book for most people to read. The difficulty arises from the speed with which it develops notations appropriate for its purposes. This will trouble mathematicians least, but students of some other disciplines may be hard pressed. The effort to stay with it is worthwhile for the approach gives a new way of looking at phenomena and brings the realisation that apparently different topics may have elements in common.

The text is divided into eight chapters: 'The background of cybernetics'; 'Learning, observation and prediction'; 'The state determined behaviour'; 'Control systems'; 'Biological controllers'; 'Teaching machines'; 'Evolution and reproduction of machines'; and 'Industrial cybernetics'. It contains a needed short glossary, a list of 91 references, seven appendices and a short subject index. There are numerous line diagrams, many of which require more explanation, and a number of photographs; those of apparatus do not help the reader for one control panel looks very much like another, and an electronic box is more or less a box.

► Electrode processes

TRANSACTIONS OF THE SYMPOSIUM ON ELECTRODE PROCESSES. Edited by *E. Yeager*. J. Wiley and Sons, Inc., New York, 1961. Pp. xiv+374. 160s.

This international symposium was held in Philadelphia in 1959 under the sponsorship of the Electrochemical Society, and the participants included such authorities as Frumkin, Bockris and Conway. The transactions consist of 18 articles interspersed by liberal discus-

sions. Twelve of the articles are concerned with adsorption, kinetics and mechanisms and consider such topics as the influence of ion adsorption at metal-solution interfaces, hydrogen electrode mechanisms, double-layer effects on electrode rate processes, rapid electrode reactions, H-D isotope effects, and the evolution and dissolution of hydrogen. The other six articles deal with electrode behaviour of single metal crystals, effects of sound-waves on potentials, and Faradaic impedance and rectification.

Probably this was one of the most important symposiums on this subject since the one held by the Faraday Society in 1947. The presentation is of a very high standard, but clearly the specialised nature of the material and the high price are going to limit the number of purchasers who will doubtless consist of a number of academic institutes and the larger electroplating firms.

► Solid surfaces

THE SURFACE CHEMISTRY OF SOLIDS. 2ND ED. By *S. J. Gregg*. Chapman and Hall, London, 1961. Pp. xvii+393. 60s.

This new edition of an admirable book provides an introductory survey of the physico-chemical phenomena at solid interfaces. Surface energy, adhesion, lubrication; adsorption of gases and catalysis; adsorption and spreading of liquids; porosity; the properties of dusts and active solids, and chemical aspects of chromatography are the main topics dealt with.

The book is not written for the specialist in these topics; it aims at providing a sound general survey 'in which the emphasis is upon the relationship between the different parts of a broad field and the unity of apparently diverse phenomena'. In this exceptionally well illustrated book the author has been unusually successful; it is one from which the reader will rapidly imbibe many important aspects of solid interfacial behaviour.

It is a pity that the processes of sublimation, solution and mobility of surface layers are not given any appreciable attention.

► Insect control

CHEMICAL CONTROL OF INSECTS (2nd Edition). By *T. F. Wert* and *J. E. Hardy*. Chapman and Hall, London, 1961. Pp. 206. 50s.

This well written and presented book gives an excellent coverage of the subject which permits the reader to assess the usefulness of different chemicals and methods of use. The authors have succeeded in presenting "a broad outline of the present scene taken from a canvas on which the emphasis is changing constantly". The importance of their subject is illustrated by the fact that in 1930 it was estimated that not less than one-tenth of human effort on basic industries such as agriculture in the Commonwealth was dissipated by insect pests.

PEOPLE in the news

● **Dr. P. J. Campbell** has been appointed to the new post of director of research and development with Riker Laboratories, Loughborough, Leics. and will be taking up duties on 1 January. A native of Northern Ireland, he graduated from Queen's University, Belfast, after an apprenticeship in retail pharmacy. Subsequently he held a management position in retail pharmacy before taking up a three-year Medical Research Council fellowship at Queen's University, where he was awarded his Ph.D. For the last three years Dr. Campbell has been associate director of research and development for another international company marketing prescription pharmaceuticals.

● **Mr. K. M. Townsend** has been appointed secretary of Geigy (Holdings) Ltd., Manchester, as from 1 January 1962 in succession to **Dr. H. B. Knuchel**, who was recently elected to the board. Mr. Townsend, who is chief accountant of Geigy (Holdings), was recently elected to the board of Ashburton Chemical Works Ltd., a manufacturing company of the Geigy group.

● **Mr. B. N. Malkin** has joined H. A. Smith Ltd., Braunston, near Rugby, as technical sales manager of the newly formed Resin Division (see page 992).

● **Professor Dr. Otto Bayer**, director of Farbenfabriken Bayer AG, Leverkusen. **Professor Dr. Walter Reppe**, research head of Badische Anilin- und Soda-Fabrik AG, Ludwigshafen-on-Rhine, and **Professor Dr. Karl Ziegler**, director of the Max-Planck Institute for Carbon Research, Mülheim-on-Ruhr, have been presented with the Siemens Ring for their services to chemistry. The ring was awarded by the chairman of the Siemens Ring Foundation in the presence of the Prime Minister of the West German State of North Rhine-Westphalia.

● **Mr. A. Meyer**, chief shareholder in Lazard Freres, New York, has been appointed a director of Montecatini, Milan.

● **Dr. R. R. Hill** has been appointed Union Carbide research fellow in chemistry at Southampton University. **Mr. J. M. Locke** has received a N.A.T.O. research fellowship in chemistry at the same university.

● **Dr. J. C. Bevington**, senior lecturer in the Department of Chemistry Birmingham University, has been granted the title of reader in the chemistry of polymers.

● **Sir Harry Melville, K.C.B., F.R.S.**, secretary of the Department of Scientific and Industrial Research, has been appointed a member of the Research Council (Council for Scientific and Industrial Research). In making this appointment, Lord Hailsham, Minister for Science, gives recognition to Sir Harry's "notable services to D.S.I.R." The appointment is personal to Sir Harry and does not mean that future secretaries of D.S.I.R. will automatically become members of the Research Council. Sir Harry, as secretary and head of the

Department, has served the Research Council in that capacity without being a full member. He became secretary of D.S.I.R. in 1956, after a distinguished academic career. His last University post was as Mason Professor of Chemistry at Birmingham University, from 1948-1956. Previously he had been Professor of Chemistry at Aberdeen University for eight years. He was elected a Fellow of the Royal Society at the age of 33, 20 years ago.

● **Mr. A. E. C. Drake** has been appointed a deputy chairman of the British Petroleum Co. Ltd. from 1 January, following Sir Harold Snow's retirement as a deputy chairman and a managing director at the end of the year.

● **Dr. F. H. Westheimer**, Professor of Chemistry, Harvard University, has been appointed Morrell lecturer at Cambridge University for the academical year 1962-63.

● **Mr. Hal Freedman**, a physics graduate of London University who was for some years London representative for Griffin and George and later joined Shandon Scientific Co. Ltd. as a product manager, has been appointed managing director of Scientific Industries International Inc. (U.K.) Ltd., an associate company of Scientific Industries Inc. of New York. He spent three years in the U.S. successfully launching a range of British instruments into the American market. On his return to the U.K. in 1960 he rejoined Shandon Scientific Co. as a sales manager.

● **Mr. J. F. Briggs**, who joined the Spondon factory of British Celanese in 1916 and has been associated with all important developments in acetate, reached the age of 90 on 5 December. He was the first deputy manager at Spondon. At his retirement many years ago, he expressed the wish to continue to attend his office at Spondon and has done so ever since. He was there as usual on his 90th birthday. Before joining British Celanese, he worked at the turn of the century with Cross and Bevan, the viscose inventors.

● **Mr. Henri Debbrabant** has been appointed chairman and managing director of the French-based South European pipeline concern.

● **Mr. George Teeling-Smith**, formerly commercial director of the Bayer Products Division, Winthrop Group Ltd., has been appointed deputy managing director of the division. **Mr. Bernard Hardisty** becomes divisional sales promotion director.

● **Professor A. C. Frazer**, Birmingham University, will give the Seventh Leverhulme Memorial Lecture under the title 'The fate of dietary fat in the body'. The lecture will be given at a meeting of the Liverpool Section, Society of Chemical Industry in Liverpool on 5 April. Further details will be announced later.

● **Mr. H. C. Mayer**, executive director and secretary of Griffin and George Ltd., Alperston, Middlesex, and its subsidiaries, has been appointed deputy managing director of the group.

● **Sir Miles Thomas**, chairman of Monsanto Chemicals Ltd. has accepted an invitation to become president of the Fronselylle Male Voice Choir, a famous Welsh choir which has close ties with Monsanto's Ruabon works. Nearly half the 62 choir members are employed by Monsanto.

● **Mr. Heinrich K. von Dellmensing**, Essen, has been appointed to the board of the West German chemical company Wasag-Chemie AG, also of Essen.

● **Mr. C. G. Ahlquist** and **Mr. J. V. Goddard** have been appointed directors of Henry Simon (Holdings) Ltd., Cheadle Heath, Stockport, with effect from 1 January.

● **Mr. J. S. Hunter**, at present assistant managing director (commercial) of the D.C.L. Chemical Division, will be transferred, with effect from 1 January 1962, to assist the chairman of the D.C.L. Chemical Group at 21 St. James's Square, London S.W.1. He will remain a divisional director of the D.C.L. Chemical Division, but without executive responsibility, and will be appointed an alternative director of British Hydrocarbon Chemicals Ltd., Grange Chemicals, Forth Chemicals Ltd., and Murgatroyd Salt and Chemical Co. Ltd.

Monsanto M.D.'s tribute to Sir Wm. Garrett

IN AN appreciation of Sir William Garrett, who recently retired from the board of Monsanto Chemicals Ltd., Mr. D. R. Mackie, managing director, says that Sir William's increasing influence in industry undoubtedly helped strengthen the recognition of Monsanto as a major independent factor in the U.K. chemical industry.

Writing in the company's house magazine, Mr. Mackie says that Sir William was the first Monsanto man to become chairman of the Association of Chemical and Allied Employers, the first Monsanto man to be chairman of the British Employers' Confederation and the first Monsanto man to become chairman of the Association of British Chemical Manufacturers.

He adds, "What a record, and, I think it is safe to say, one which will never be beaten".

Commercial News

Aspro-Nicholas

Ordinary shareholders of Aspro-Nicholas Ltd. are being asked if they would rather receive their annual dividends in two instalments instead of four as at present. A second 3½% interim is declared for the current year (same).

Irish Plastic Packaging

The new joint Metal Box and Irish Glass Bottle company has now been set up in Eire under the title Irish Plastic Packaging, with issued capital of £201,000 and a production unit in Dublin. Directors are Mr. J. McGrath, chairman, Mr. J. Griffin (managing director of Irish Glass Bottle), Dr. F. M. Carey (Irish Glass Bottle), who is general manager of the new company, Mr. P. McGrath, Mr. D. Ducat (managing director Metal Box), Mr. D. J. Liston and Mr. J. M. Jackson.

McKechnie Brothers

Intensive competition for raw materials, with stock losses and delays in completion of new equipment, adversely affected results on the chemicals side at Widnes, said Mr. John Duncan McKechnie, chairman and managing director of McKechnie Brothers Ltd. in his annual statement. The new equipment is expected to help cut production costs during 1961/62. Plans are in hand for continuing the modernisation of the Widnes Works and the company is investigating development into other products which would link up with those already made at Widnes.

A.K.U.

An interim dividend of 4% (same) is to be paid for 1961 by *Algemene Kunstzijde Unie, Arnhem*. Last year, the dividend totalled 17%, plus a 5% share bonus to mark the company's fiftieth anniversary.

Olin Mathieson

Olin Mathieson Chemical, U.S., announce a regular quarterly dividend of 25 cents/share (same) payable 9 March.

General Aniline

The American Shareholders Committee of the General Aniline and Film Corporation, has appealed to shareholders to urge U.S. Congress representatives to support the Bill whereby the company would be sold to private U.S. interests. The committee's chairman states that G.A.F. could not live through the competition of privately-owned firms unless it was itself sold to private interests.

The committee, which has hitherto supported an out-of-court settlement between the U.S. and Interhandel AG, Basle, the Swiss holding company which contests the right to sell, now states that the intransigence and lack of understand-

- New Irish packaging company set up
- Equipment delays affect McKechnie results
- Montecatini 10-month sales up 12%
- Phoenix-Rheinrohr plan Italian tie-up

ing of the Swiss company meant that the problem could be tackled only by jurisdiction.

The Swiss Press notes surprise at this opinion since Interhandel have only recently made suggestions to the Department of Justice for a settlement out of court.

Montecatini

In the first 10 months of 1961, sales by the Montecatini Group totalled 320,000 million lire, or about 12% up on the same period last year, when the total was 285,000 million lire.

At the recent meeting of shareholders, it was stated that it had been decided not to go ahead with the planned absorption of Soc. Vetrocok. It was also reported that the company's new Brindisi plant would go on stream early in 1962.

In Sicily, the group plans a new plant for the production of ammonia, in addition to doubling capacity of the Porto Empedocle fertiliser plant, expansion of the plant at Campofranco and a new plant at the potash mine at Racalmut.

Phoenix-Rheinrohr

The Düsseldorf, West Germany, steel products company, Phoenix-Rheinrohr AG, plans to take over a share majority in the Terni, Italy, producer of petrochemical, chemical and oil industry plant and packaging concern, *Officine Meccaniche e Fonderie A. Bosco*. The plan is for an exchange of know-how and information between the two concerns.

Market Reports

YEAR-END APPROACH SLOWS TRADING

LONDON Most sections of the industrial chemicals market report a quieter tendency with only a small volume of new business being placed. These conditions are not unusual for a period when the main emphasis is on contract renewals for the coming year. At the time of this report prices are unchanged and steady, while the supply position appears to present no difficulty in any direction.

There has been little of fresh interest to report on the agricultural chemicals and relatively quiet conditions continue. The movement in the coal tar products has been perhaps less active than of late due to seasonal influences.

MANCHESTER Stocktaking and other seasonal influences have been in evidence and trading conditions have been relatively quiet as far as new busi-

ness is concerned. There is little likelihood of a recovery until after the holidays but traders are hopeful that this recovery will not be long delayed. There has been little change in prices.

Soc. Chimica Sarda

The new joint company of Rumianca, Turin, and Pittsburg Plate Glass International, Geneva, has been formed on a 50-50 basis under the title Soc. Chimica Sarda. With a capital of 50 million lire, this company will build and operate plants in Cagliari, Sardinia, for the production of organics and inorganics. Dr. Renato Gualino has been appointed chairman.

Rumianca earlier this year (C.A., 24 June, p. 1039) announced plans to make caustic soda chlorine, p.v.c. and polythene in Sardinia.

Reichhold Chemical

Reichhold Chemicals Inc. report for the first three-quarters of the current year net profit of some \$50,000 (\$2,490,000) after increased turnover of \$76,800,000 (\$74,400,000). Before addition of profits from investments, the company actually recorded a working loss for the period of \$210,000, as against a working profit of \$1,710,000 for the 1960 period.

INCREASE OF CAPITAL

LONZA AG, Basle, are to recommend at an extraordinary general meeting to be held on 25 January an increase in capital from S.Fr. 50 million to S.Fr. 60 million.

In the market for the light and heavy tar products a quietly steady movement into consumption is reported, while slacker conditions have been experienced in the compounds and most other descriptions of fertilisers.

SCOTLAND There has been little or no change in conditions generally. Demands for the home market have been fairly moderate, perhaps in some cases due to the approaching end of the year. However, there have been some inquiries for forward deliveries, and contract requirements for 1962 are still showing interest. The position in regard to export is still satisfactory.

TRADE NOTES

Fibrous glass insulation

Use of fibrous glass insulating materials for a wide range of industrial, military and consumer applications is illustrated in a new bulletin from Fibrous Glass-Products Inc., Mountaintop, Pa., U.S., a subsidiary of Pall Corporation. Bulletin F101 covers five major product areas—thermal insulation, acoustical insulation, vibration isolation, packaging dunnage, and filtration.

Petro bond sand

F. W. Berk and Co. Ltd. have cut the price of their Petro bond sand by between £5 and £7 10s a ton for deliveries in 1, 5 and 10 ton lots.

Rentokil Laboratories Ltd.

On 1 January Rentokil Products Ltd. becomes the Products Division of Rentokil Laboratories Ltd. In 1962 nearly all the companies in the Rentokil Group will be known as specialist divisions of the new company, Rentokil Laboratories Ltd. The company claims that it is now Europe's largest pest control organisation, timber preservation being but one of many diverse activities.

In addition to the well-known Rentokil timber preservatives and Rentofab mothproofers, the Rentokil Products Division markets Rodine rodenticides and Tritox systemic insecticide. Rodine was originally made by Thomas Harley

Ltd., and Tritox by Associated Fumigators Ltd., both companies having been acquired by Rentokil and these retail products absorbed by the Products Division.

Rentokil products are manufactured at Leatherhead and Perth; sales manager W. M. Sprout operates from Felcourt, East Grinstead, Sussex; and the company maintains the Woodworm and Dry Rot Free Advice Centre at 16 Dover Street, London, W.1.

Change of address

From 1 January, Orr Products, pump manufacturers, are moving to Goodridge Avenue, Quedgeley, Gloucester (Gloucester 27455).

Griffin and George science teaching awards

FIRST prize of £25 in the Griffin and George awards for science teaching by practising teachers in secondary schools was won by "A Scottish '0' grade chemistry course based on atomic and ionic theory" (Mr. Alex H. Johnstone, George Watson's Boys' College, Edinburgh 10).

The money prizes, worth over 100 guineas, are given annually by the Griffin and George Group, who claim to be the largest manufacturers and suppliers of modern laboratory equipment in Europe.

Changes in wholesale prices of chemicals

WHOLESALE price index of the Board of Trade for November showed a marginal rise for chemicals on the previous month, but a fall compared with the levels of a year ago. Based on a 1954 average of 100, the index shows the following monthly averages:

	Nov. 1961	Oct. 1961	Nov. 1960
Chemicals & allied industries:			
Total sales ...	103.1*	103.0*	103.6
Home sales ...	105.3*	105.2*	105.1
Lube oils & greases ...	121.5*	121.5*	114.2
General chemicals ...	103.7*	103.7*	105.1
Toiletries ...	120.1*	120.1*	115.6
Paint ...	112.6*	119.9*	108.2
Soap ...	132.8*	130.6*	129.0
Detergents ...	97.8	97.8	103.5
Syn. resins & plastics materials	83.1*	83.6*	87.7
Commodities wholly or partly imported			
Oils, resins & gums:			
Linseed, crude, naked, ex-works ...	144.9*	150.6	132.0
Palm oil, c.i.f. in bulk ...	99.4*	99.4	9.75
Whale oil, acid, soft, naked, ex-works ...	59.2*	65.8	115.9
Pyrites, c.i.f., U.K. ports	62.8	62.8	64.2
Sulphur, crude for acid, c.i.f. ...	72.1	72.1	75.4
	* Provisional		

Drugs and medicines exempted from P.T.

A new Treasury order (Purchase Tax (No. 2) Order, 1961—S.I. 2285/61) extends the schedule of essential drugs and medicines exempt from purchase tax. New items exempted from tax and extensions of existing items are given in the *Board of Trade Journal*, 15 December, page 1209.

ACID & ALKALI RESISTING

FLOORS & LININGS

FOR ALL TRADES

COMPLETE PLANTS FOR PICKLING FUME EXTRACTION & EFFLUENT TREATMENT

PICKLING TANKS 90 FEET LONG WORKING SUCCESSFULLY

RIZISTAL

ALL BRITISH GUARANTEED PRODUCTS



HAVE YOU HEARD ABOUT

"KONDUCT"

THE HEAT CONDUCTING CEMENT

WRITE NOW FOR

TECHNICAL BOOKLET & PRICE LIST

JOHN L. LORD & SON
WELLINGTON CEMENT WORKS
BURY, LANCASHIRE

GRAMS: 'CEMENT'
TELEPHONE: BURY 4617

NEW PATENTS

By permission of the Controller, H.M. Stationery Office, the following extracts are reproduced from the 'Official Journal (Patents)', which is available from the Patent Office (Sales Branch), 25 Southampton Buildings, Chancery Lane, London W.C.2., price 3s 6d including postage; annual subscription £8 2s.

Specifications filed in connection with the acceptances in the following list will be open to public inspection on the dates shown. Opposition to the grant of a patent on any of the applications listed may be lodged by filing patents form 12 at any time within the prescribed period.

ACCEPTANCES

Open to public inspection 24 January

Conversion of steroidal α,β unsaturated ketones to olefins. National Research Development Corp. **887 706**

Process for the manufacture of ϵ -caprolactam. Farbwerke Hoechst AG. **887 718**

Vaccines. Glaxo Laboratories Ltd. **888 180**

Copolymerisation. Pechiney. **888 014**

Process for preparing high molecular weight polymers of α -olefins. Montecatini. [Addition to 828 791.] **887 707**

Process for the production of elastomeric plastics. Farbenfabriken Bayer AG. **887 708**

Cyclopentanophenanthrene derivatives. Syntex S.A. **887 721**

Hydrogenation of hydrocarbons. Rabo, J. A. **887 794**

Preparation of alkali-metal poly silicates. Montecatini. **887 972**

Steroids. Scherico Ltd. **887 814**

Method for the production of polyhydric alcohols. Skanska Attifabriken A.B. **888 144**

Citric acid products and preparation thereof. Pfizer & Co., Inc., Chas. **887 973**

Polymerisation of olefins. Ruhrchemie AG. **887 974**

Podophyllin acid derivatives and process for their production. Sandoz Ltd. **887 817**

Organopolysiloxane compositions convertible to elastomers. Wacker-Chemie GmbH. **887 976**

Halogeno-triazine dyestuffs, their manufacture and use. Ciba Ltd. **887 723**

Methoxy indolyl propylamine. Laboratoires Francaise de Chimiotherapie. **887 915**

Benzo-1,3-thiazinediones-(2,4). Thomae GmbH, Karl (Dehn, F. B.) **887 709**

Processes for the preparation of benzo-1,3-thiazinediones-(2,4). Thomae GmbH, Karl. **887 701**

Polystyrene composition. Commercial Plastics Ltd. **888 161**

Reaction products of epoxyalated compositions and process. Richardson Co. **887 702**

Preparation of α,β,γ -unsaturated carboxylic derivatives. Montecatini. **888 162**

Heterocyclic sulphonamide derivatives. Merck & Co., Inc. **887 711**

Manufacture of polymeric materials. Imperial Chemical Industries Ltd. **887 724**

Method for the preparation of α -amino caprylic acid and its esters. Montecatini. **888 163**

Metalliferous triazine monoazodyestuffs and their manufacture and use. Ciba Ltd. **887 867**

4-methyl-3-oxo- Δ^4 -steroids. British Drug Houses Ltd. **888 165**

Oxidation of organic compounds to carboxylic acids by means of nitric acid. Farbwerke Hoechst AG. **887 731**

Monoazo dyestuffs containing pyrazole rings. Farbenfabriken Bayer AG. **888 167**

Preparation of hot-pressed boron nitride. British Ceramic Research Association. **887 658**

Monoazo dyestuffs. Cassella Farbwerke Mainkur AG. **887 870**

Heat resisting material comprising self-bonded silicon nitride with silicon carbide dispersed thereon and method for producing it. National Research Development Corporation. **887 942**

Preparation of members of the tetracycline series. American Cyanamid Co. **887 671**

Process for the purification of 2-ethyl-cis-crotonyl-urea. Miles Laboratories Inc. [Addition to 743 164 and 864 284.] **887 666**

Hardenable compositions comprising epoxide compounds and tetrahydrofurane. Ciba Ltd. **888 149**

Polyoxamides. Imperial Chemical Industries Ltd. **888 150**

Polypropylene yarns. Montecatini. [Addition to 810 023.] **887 673**

Separation of benzene from hydrocarbon mixtures. Imperial Chemical Industries Ltd. **887 871**

Process for preparing the antibiotic cycloheximide and its isomer by fermentation. Tanabe Seiyaku Co. Ltd. **887 825**

Polyvinyl chloride compositions. Imperial Chemical Industries Ltd. **887 669**

Pharmaceutical preparations. Upjohn Co. **887 872**

Process for the production of caustic alkali solutions from alkali metal amalgams and apparatus therefor. Imperial Chemical Industries Ltd. **887 670**

Purification process for isocyanates. Imperial Chemical Industries Ltd. **887 874**

Thiophosphoric acid esters. American Cyanamid Co. **887 676**

Bonding polyolefins to metals by means of a chemically modified polyolefin resin. Esso Research & Engineering Co. **887 875**

Anthraquinone dyestuffs and process for their manufacture. Ciba Ltd. **887 876**

Production of aliphatic alcohols. Distillers Co. Ltd. **887 678**

Carboxylic acid amides. Montecatini. **888 164**

Condensation products and polymerisable compositions. Badische Anilin- und Soda-Fabrik AG. [Addition to 848 400.] **887 957**

Method for the preparation of aminoazolesulphides. Goodrich Co., B. F. **887 856**

Manufacture of ammonium sulphate. Imperial Chemical Industries Ltd. **888,031**

Process for the preparation of 6 α -methyl-16-methylene steroids. British Drug Houses Ltd. **887 861**

Production of polymers from monomeric epoxy compounds. Petrochemicals Ltd. **887 988**

16-Methylene steroids. British Drug Houses Ltd. **887 684**

Production of symmetrically substituted conjugated hexatrienes and their vinyllogues. Badische Anilin- & Soda-Fabrik AG. **887 686**

Exodicyclopentadiene dioxide. Union Carbide Corp. **887 778**

Process for the production of alkanols. Distillers Co. Ltd. **887 745**

Dihydroxy steroids. American Cyanamid Co. **887 748**

Process for the manufacture of alkali metal phosphates. Knapsack-Griesheim AG. **887 749**

Production of β -picoline. Distillers Co. Ltd. **887 688**

Polymerisation of unsaturated hydrocarbons. Polymer Corp. Ltd. **887 779**

Preparation of O,O-dialkyl thiophosphoryl chlorides. Shell Internationale Research Maatschappij N.V. **887 689**

Telomers of tetrafluoroethylene. Du Pont de Nemours & Co., E. I. **887 750**

Dyestuffs of the perylene tetracarboxylic acid diimide series and process for their manufacture. Ciba Ltd. **887 971**

Anthraquinone vat dyestuffs. Ciba Ltd. **887 753**

Process for producing glutamic acid from beet sugar. Ajinomoto Co. Inc. **887 879**

Steroids. Scherico Ltd. [Divided out of 887 814.] **887 815**

Tetracycline amides. American Cyanamid Co. **887 754**

Process and composition for the manufacture of epoxy-resins. Ciba Ltd. **887 996**

Aromatic fluorine compounds employed in the production of polymeric gums. National Polychemicals, Inc. **887 691**

Production of esters and the esters thus produced. Harburger Fettechemie Brinckman & Mergell GmbH. **887 899**

Production of highly polymeric quaternary ammonium compounds. Badische Anilin- & Soda-Fabrik AG. **887 900**

Hydrogenation process. Esso Research & Engineering Co. **888 082**

Derivatives of 1,3,3 trimethyl-spiro (2²H-11-benzopyran-2,2'-indoline). National Cash Register Co. **887 958**

Anthelmintic composition containing dithiazanine iodide. General Aniline & Film Corp. **887 757**

Unsaturated aldehydes of the vitamin A series. Farbenfabriken Bayer AG. **887 819**

Production of trivalent live poliomyelitis vaccine. American Cyanamid Co. **888 171**

Stabilising cyclic ethers against oxidation. Du Pont de Nemours & Co., E. I. **888 096**

Chlorinated copolymers of ethylene. Farbenfabriken Bayer AG. **887 961**

Preparation of high quality solid olefin polymers. Standard Oil Co. **888 027**

Process for the manufacture of lithium aluminium hydride. Hoffmann-La Roche & Co. AG, F. **888 045**

Derivatives of 3-alkyl, 3'-methyl-spiro-benzothiazole-2,2'-(2H-11-benzopyran)]. National Cash Register Co. **887 902**

Organic polymer mixtures. Polyplastic, and Pneumatiques & Caoutchouc Manufacture Kleber Colombes. **888 046**

Process for the production of propylum salts and substitution products derived therefrom. Shell Internationale Research Maatschappij N.V. **887 693**

Process for the production of tropones or theotropenes. Shell Internationale Research Maatschappij N.V. **887 694**

Process for vulcanising olefin polymers and copolymers. Montecatini. **887 763**

Curing epoxy butadienes. F.M.C. Corp. **888 134**

Organopolysiloxane elastomeric foams. Dow Corning Corp. **887 905**

Substituted urea compounds. Upjohn Co. **887 886**

Isomerisation of olefins. Esso Research & Engineering Co. **887 903**

Process for the preparation of olefin copolymers. Montecatini and Ziegler. **888 050**

Process for the production of graft copolymers. Grace & Co., W. R. **887 887**

Antibacterial agents. Beecham Research Laboratories Ltd. **888 110**

Process for the purification of isoprene. Shell Internationale Research Maatschappij N.V. **887 908**

Post-graduate courses at Kingston Technical College

A post-graduate course of nine lectures on 'Heterogeneous catalysis' is to be held at Kingston Technical College on Wednesday evenings, at 7 p.m., commencing 17 January 1962. Another course at the College will comprise a series of six post-graduate lectures on 'Some recent advances in heterocyclic chemistry' to be given by Dr. D. R. Palmer on Tuesday evenings, 7-9 p.m., commencing 13 February 1962.

Further details of these courses are available from: The Principal, Kingston Technical College, Fasset Road, Kingston upon Thames, Surrey.

"VULCAN" CARBOY HAMPERS SAFETY CRATES PACKED CARBOYS

HARRIS (LOSTOCK GRALAM) LTD. Lostock Gralam, Northwich, Cheshire

CLASSIFIED ADVERTISEMENTS

CLASSIFIED RATES: All sections 5d. per word. Minimum 8/- . Three or more insertions 4d. per word. Box Number 2/- extra.

SEMI-DISPLAY: 30/- per inch. Three or more insertions 25/- per inch.

EDUCATIONAL

CHEMICAL ENGINEERING. Guaranteed Home Study Courses for A.M.I.Chem.E. exam. The highest percentage of successful candidates—up to one third in consecutive years—have been trained by T.I.G.B. Everyone seeking promotion in the Chemical and Allied Industries should send for the T.I.G.B. "Guide to Success". 100 pages of expert advice and details of wide range of guaranteed (Exam and Diploma) Courses, including A.M.I.Mech.E., A.M.I.Prod.E., B.Sc.(Eng.). Courses in individual subjects also available. Send for your copy today—FREE. T.I.G.B. (Dept. 84), 29 Wright's Lane, London, W.8.

BRADFORD INSTITUTE OF TECHNOLOGY DEPARTMENT OF CHEMICAL TECHNOLOGY

Short Course on

"Chemical Applications of Electron Spin Resonance"

An introductory course surveying the applications of electron spin resonance in the chemistry of free radicals, polymers, and transition metal ions will be held on Thursday and Friday, 15th and 16th February, 1962. The speakers include Professor D. J. E. Ingram, Dr. P. B. Ayscough, A. Carrington, B. A. Coles and A. Horsfield, and Mr. M. G. Ormerod. Fee £2 5s.

Further details and application forms may be obtained from the Registrar, Bradford Institute of Technology, Bradford, 7.

FOR SALE

CHARCOAL, ANIMAL AND VEGETABLE, Horticultural burning, filtering, disinfecting, medicinal. Also lumps, ground and granulated. **THOMAS HILL-JONES, INVICTA WORKS, BOW COMMON LANE, LONDON, E.3 (TELEPHONE: EAST 3285).**

PATENTS & TRADE MARKS

KINGS PATENT AGENCY, LTD. (B. T. King, A.I.Mech.E., Patent Agent), 146a Queen Victoria Street, London, E.C.4. City 6161. Booklet on request.

The proprietor of British Patent No. 802868, entitled "Flexible resilient cellular resin products", offers same for license or otherwise to ensure practical working in Great Britain. Inquiries to Singer, Stern & Carlberg, 140 So. Dearborn Street, Chicago 3, Illinois, U.S.A.

PLANT AND MACHINERY FOR SALE

Baker-Perkins Class BB "Double Naben" Bladed Steam Jacketed Mixers. Four—size 12 and Three—size 11, of 20 and 8 gallons respectively.

Oil Jacketed Double Trough Mixer 48 in. by 36 in. by 29 in. deep. Paddle Blades. Bottom Outlets.

Barron 'U' Sifter Mixer 96 in. by 33 in. by 33 in. with 10 H.P. A.C. Motor.

Gardner 'U' Sifter-Mixers 66 in. by 24 in. by 24 in. with 5 H.P. A.C. Motors. Four available, of modern streamlined design.

Horizontal 'U' Trough Mixers 48 in. by 18 in. by 22 in. Three—Tilting type, Paddle Blades. Glanded.

Over-Arm Twin-Blade, Tilting, 30 gallon Mixers with 3 H.P. Geared Motors. Five available.

Lying at our No. 2 Depot, Willow Tree Works, Swallowfield, Berkshire.

Apply: Winkworth Machinery Limited, 65 High Street, Staines, Middlesex. Telephone 55951.

Phone 55298 Staines.

(Five) Stainless Steel Duplex 'Z' Blade Mixers 43"×40"×28" deep.

(Three) B. Perkins Double Naben Jac. Mixers 30"×28"×28".

(Three) B. Perkins Jac. Mixers with Reverse Duplex Blades, 70"×53"×42" deep.

(Two) B. Perkins Heavy Duplex Serrated 'Z' Blade Mixers 54"×44"×36" deep.

Stainless Steel Duplex 'Z' Blade Vacuum Mixer 3'×3'×3'.

(Thirty) Gardner & other 'U' Trough Mixers up to 9' 6"×3'×3'.

(Nine) Condensers 8' 2"×16" diam. 232— $\frac{3}{4}$ " Brass Tubes 100 w.p. 34' continuous Drying Oven/Steel Mesh Conveyor 36" wide, heating unit and (2) Fans.

(60) Glass Lined Cyl. Enc. Tanks up to 9,000 galls.

Send for Lists.

**HARRY H. GARDHAM & CO. LTD.,
100 CHURCH STREET, STAINES.**

WORK WANTED & OFFERED

**CRUSHING, GRINDING, MIXING and DRYING for the trade
THE CRACK PULVERISING MILLS LTD.**

Plantation House,
Mincing Lane,
London, E.C.2.

BOX NUMBERS: Reply c/o "Chemical Age"

• Bouverie House • Fleet Street EC4.

1962

Chemical Age

DIRECTORY

and WHO'S WHO

Price 45/- Privilege price to
Chemical Age subscribers 25/-

(Packing and postage 3/6 extra)

Orders are now being accepted for the new edition of this indispensable source of reference to the chemical industry which will be ready for dispatch early in December 1961. In addition to a greatly enlarged Buyers' Guide, now divided into three sections for easy reference—Chemicals, Chemical Plant & Equipment and Laboratory Apparatus & Scientific Instruments—the Directory will contain the following exclusive features:—

WHO'S WHO

This section has been revised, enlarged, and now contains biographical details of nearly 5,000 leading personalities in chemistry, chemical manufacturing and chemical engineering.

WHO OWNS WHOM

An analysis of the various groups in the chemical industry which lists their wholly, or partially owned subsidiaries. The information is up to date and takes account of the most recent mergers. An index provides easy reference to companies listed.

CONSULTANT CHEMISTS and CHEMICAL ENGINEERS

This register is being included for the first time. Consultants are listed under the subjects in which they specialise, as well as alphabetically.

**No other Directory contains so much information—make sure
of your copy by completing the reply paid order form below.**

ORDER FORM

To Chemical Age, 154 Fleet Street, London, E.C.4

We wish to order.....copy/copies of the 1962 Chemical Age DIRECTORY and WHO'S
WHO at £1 . 5 . 0 (plus 3/6 postage and packing), the special rate to Chemical Age subscribers.

Name

Address

Date..... Signed.....

If this form is folded as shown overleaf no postage will be required. If a remittance is sent with this order it must be enclosed in an envelope and stamped.

2nd FOLD

Postage
will be
paid by
the
Licensee

No Postage
Stamp
necessary if
posted in
Great Britain
or
Northern Ireland

BUSINESS REPLY FOLDER
Licence No. 2501

CHEMICAL AGE
154-160 FLEET STREET
LONDON, E.C.4

1st FOLD

3rd FOLD

PLEASE CUT ALONG DOTTED LINE

*is
yours
a*



DECOLOURISING
problem.

...specify

ACTIBON

THE
HIGHLY ACTIVATED
DECOLOURISING
CARBON

its THE
CLEAR SOLUTION



THE CLYDESDALE CHEMICAL CO., LTD.

142 QUEEN STREET,

Phone Central 5247-8

GLASGOW, C.I.

Grams "Cactus" Glasgow.

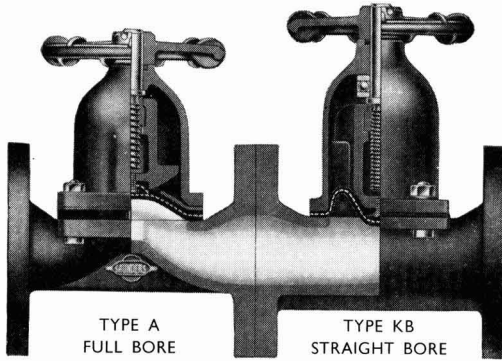

So many Saunders Valve variants for so many Industrial duties

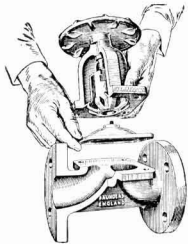

Handwheel Operated valves with rubber, glass, lead, nylon or titanium lined bodies for hundreds of difficult fluids. Chainwheel Operation for many inaccessible locations such as overhead pipelines. Small models for laboratory, test bed and kindred duties—but still having the same sure closure and isolation of mechanism so valuable in the larger types.

For quick action, Lever Operated valves are supplied to many establishments and, where remote or automatic control is essential, one or another of the Power Operated models is recommended. Amongst these are the Diaphragm Operated Pressure Closing.

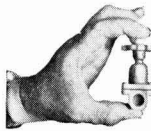

Pressure Opening with automatic spring action to close, and Piston Operated valves. Direct Electrical Actuation can also be provided for the full range of sizes of both A and KB type valves. For particularly exacting duties

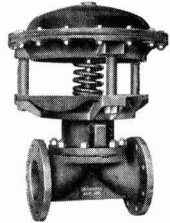

Saunders Diaphragm Valves are supplied with

stainless steel, alloy or plastic bodies and the range of diaphragms is now so wide that virtually every delicate, difficult or dangerous fluid can be safely and surely handled.

The Saunders Technical Handbook explains the full range of types and lists the diaphragm grades available with recommendations as to the most suitable body and diaphragm specifications for hundreds of fluids. May we send a copy for your bookshelf?

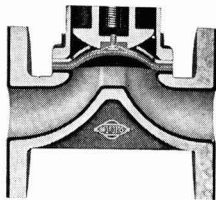

SAUNDERS
DIAPHRAGM
VALVES

SAUNDERS VALVE COMPANY LIMITED
Diaphragm Valve Division
CWMBRAN · MONMOUTHSHIRE · Telephone: Cwmbran 3081

The **Jefco**



FACE SCREEN

Reg. Design 751914 Patent applied for

Perfect protection when grinding or machining. Comfortable to wear, stands clear of the face, adjustable to any angle, non-splinter front easily renewable.

Protection for spraying fruit trees, &c.

Also Jefco Face Screen for Auto Cyclists.

J. & E. FERRIS LTD

33 Museum St., London, W.C.1

Telephone: MUSeum 2876

STILL
PRE-EMINENT
FOR
SODIUM CHLORATE

KW
CHEMICALS LTD
KW

55/57
HIGH HOLBORN
LONDON W.C.1
T.A. "CHLORATE"
T.N. CHANGERY
7981/7