

1995 BUYER'S GUIDE

# Environmental PROTECTION

DEDICATED TO THE CONTROL OF AIR AND WATER POLLUTION, WASTEWATER AND HAZARDOUS MATERIALS

JANUARY 1995

**Crystal Clear**  
**Clean Air Goals**



# Where Do I Find Everything for Process Measurement and Control?

**NEW** **OMEGA...Of Course!**

**FREE!**

1995/96  
HOT OFF EDITION  
THE PRESS!

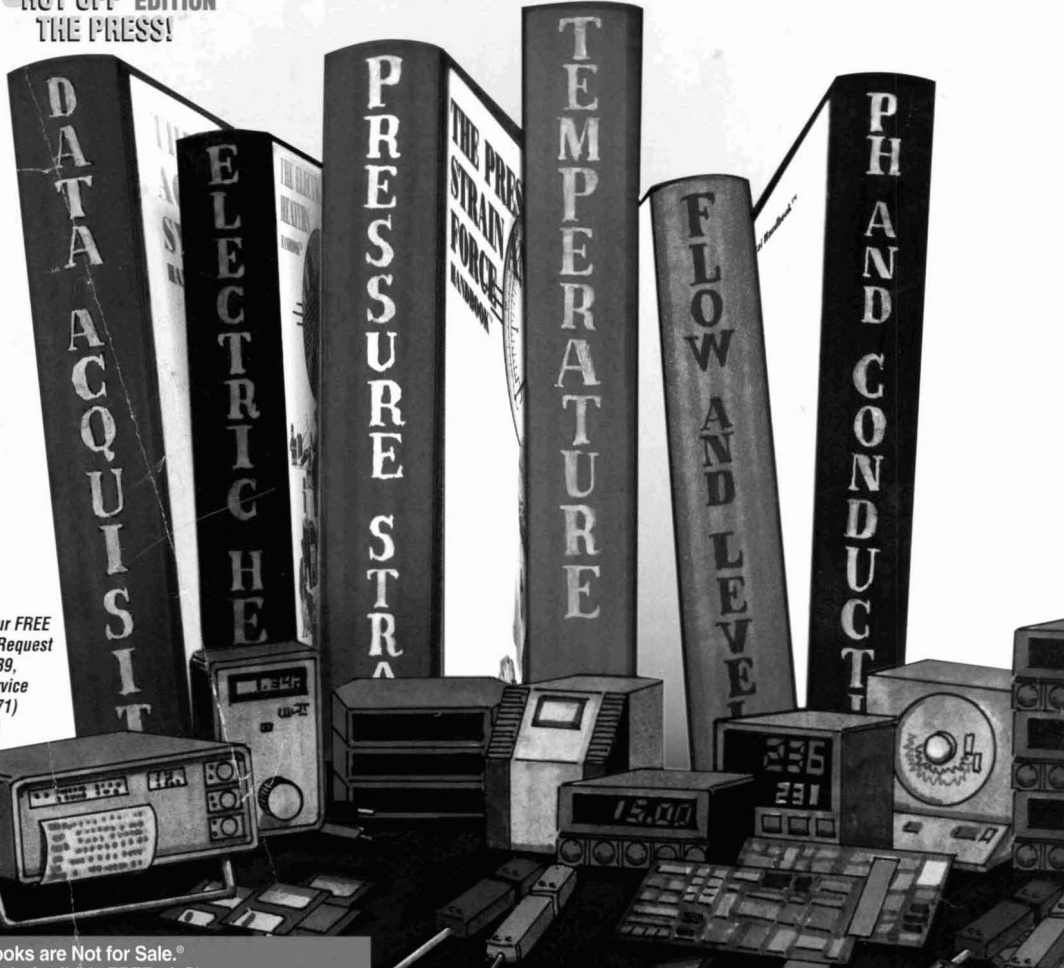

To Request Your FREE Handbook Set Request Document #9989, OMEGAFax Service (1-800-848-4271) or Circle No. 1

These Books are Not for Sale.<sup>®</sup>  
They're Only Available FREE of Charge to People Like Yourself, Who Need to Know!

## The OMEGA Complete Handbook and Encyclopedia Library

- Seven Hardcover Volumes, with Over 5000 Full-Color Pages
- Hundreds of Pages of Valuable Technical Reference Material
- Thousands of Items In Stock for Fast, Off-the-Shelf Delivery
- Full Specifications and Pricing Always Listed



## ISO 9001 Certified Corporate Quality

OMEGA has been certified as being in compliance with the requirements of ANSI/ASQC-Q91 for the design, manufacture, and distribution of temperature, flow, pH, heating, data acquisition, pressure, environmental instruments and related process equipment, accessories, and custom assemblies, plus provision of calibration services and technical and scientific literature. We continually strive to maintain the worldwide quality standards set forth by ISO (International Organization for Standardization).



For RUSH Handbook Service, Call:  
**(203) 359-7874<sup>SM</sup>**  
**(203) 359-RUSH**



**OMEGA Engineering, Inc.**  
One Omega Drive, P.O. Box 4047  
Stamford, CT 06907-0047  
©1995 OMEGA ENGINEERING, INC., ALL RIGHTS RESERVED.

# Environmental PROTECTION

January 1995  
Card Expires March 1995  
Reader Service Card

For FREE information on products advertised in this issue, circle their Reader Service Number on the card below. Please type or print clearly and answer all the questions on the card.

PLEASE SEND ME FREE INFORMATION ON THE FOLLOWING ITEMS:

1	2	3	4	5	6	7	8	9	10	11	12	13	14	15	16	17	18	19	20
21	22	23	24	25	26	27	28	29	30	31	32	33	34	35	36	37	38	39	40
41	42	43	44	45	46	47	48	49	50	51	52	53	54	55	56	57	58	59	60
61	62	63	64	65	66	67	68	69	70	71	72	73	74	75	76	77	78	79	80
81	82	83	84	85	86	87	88	89	90	91	92	93	94	95	96	97	98	99	100
101	102	103	104	105	106	107	108	109	110	111	112	113	114	115	116	117	118	119	120
121	122	123	124	125	126	127	128	129	130	131	132	133	134	135	136	137	138	139	140
141	142	143	144	145	146	147	148	149	150	151	152	153	154	155	156	157	158	159	160
161	162	163	164	165	166	167	168	169	170	171	172	173	174	175	176	177	178	179	180
181	182	183	184	185	186	187	188	189	190	191	192	193	194	195	196	197	198	199	200

For faster service—photocopy this side only and send to our FAX # (817) 662-7075

PLEASE PRINT OR AFFIX LABEL HERE

NAME \_\_\_\_\_

COMPANY \_\_\_\_\_

ADDRESS \_\_\_\_\_  Home  Bus.

CITY \_\_\_\_\_ STATE \_\_\_\_\_ ZIP \_\_\_\_\_

- YES, I would like to receive/continue to receive Environmental Protection.
- NO, I'm not interested at this time.

Signature \_\_\_\_\_ Signature Required For FREE Subscription Date \_\_\_\_\_

Title \_\_\_\_\_

Business Phone (\_\_\_\_\_) \_\_\_\_\_ FAX No. (\_\_\_\_\_) \_\_\_\_\_

Home Phone (\_\_\_\_\_) \_\_\_\_\_

1. Function which best describes your activity in Pollution Control (check only one):

- A  Corporate responsibility for Pollution Control
- B  Manage all Pollution Control Operations at this location
- C  Supervise sub-group in Pollution Control Operations
- D  Provide professional consulting service on Pollution Control
- E  Provide staff environmental service on Pollution Control
- Z  Other (please specify) \_\_\_\_\_

2. Type of Business (check only one):

A  Manufacturing. If manufacturing, please check the appropriate SIC (check only one):

- |  |  |
|--|--|
| <input type="checkbox"/> (20) Food           | <input type="checkbox"/> (30) Rubber/Plastic                 |
| <input type="checkbox"/> (21) Tobacco        | <input type="checkbox"/> (31) Leather                        |
| <input type="checkbox"/> (22) Textile        | <input type="checkbox"/> (32) Stone/Clay/Glass               |
| <input type="checkbox"/> (23) Apparel        | <input type="checkbox"/> (33) Primary Metal                  |
| <input type="checkbox"/> (24) Lumber & Wood  | <input type="checkbox"/> (34) Fab. Metal                     |
| <input type="checkbox"/> (25) Furniture      | <input type="checkbox"/> (35) Mach., except Elect.           |
| <input type="checkbox"/> (26) Paper          | <input type="checkbox"/> (36) Elect. & Electron. Mach.       |
| <input type="checkbox"/> (27) Print/Publish  | <input type="checkbox"/> (37) Trans. Equip.                  |
| <input type="checkbox"/> (28) Chemicals      | <input type="checkbox"/> (38) Instru/meas/analyz/controlling |
| <input type="checkbox"/> (29) Petrol. & Coal | <input type="checkbox"/> (39) Miscellaneous Mfg.             |

- B  Mining
- C  Agriculture
- D  Engineering & Contracting
- L  Consulting
- M  Insurance
- E  Utilities, public, private & cooperative
- F  Govt. including municipal or district sanitary water or wastewater trmnt. sys. or plants

Type of Govt:

- G  City  H  County
- I  State  J  Federal
- K  Transportation
- N  Labs  O  Training  P  Real Estate
- Z  Misc. Services \_\_\_\_\_

(please specify)

3. Approximate number of employees at this address (check only one):

- |                                    |                                      |  |
|------------------------------------|--------------------------------------|--|
| A <input type="checkbox"/> 1-19    | E <input type="checkbox"/> 250-499   | H <input type="checkbox"/> 1500-2499   |
| B <input type="checkbox"/> 20-49   | F <input type="checkbox"/> 500-999   | I <input type="checkbox"/> 2500 and up |
| C <input type="checkbox"/> 50-99   | G <input type="checkbox"/> 1000-1499 |  |
| D <input type="checkbox"/> 100-249 |                                      |  |

4. In your job function do you recommend, specify or purchase? (check all that apply):

- A  Pollution Control Equipment
  - B  Instrumentation
  - C  Chemicals
  - D  Parts & equipment for maintenance operation and control
  - E  Services/Consulting
  - F  None of the above \_\_\_\_\_
- (please specify)

5. What types of Pollution Control are you responsible for? (check all that apply):

- |   |   |
|---|---|
| A <input type="checkbox"/> Air                  | F <input type="checkbox"/> Toxic & hazardous material         |
| B <input type="checkbox"/> Water                | G <input type="checkbox"/> Energy control/energy conservation |
| C <input type="checkbox"/> Noise                | H <input type="checkbox"/> None of the above                  |
| D <input type="checkbox"/> Solid waste disposal |   |
| E <input type="checkbox"/> Industrial hygiene   |   |
- (please specify)

6. Which of the following publications do you receive personally addressed to you? (check all that apply):

- A  Pollution Engineering
- B  Environment Today
- C  Hazmat World
- D  Pollution Equipment News
- E  The National Environmental Journal
- F  Water Environment & Technology
- G  None of the above \_\_\_\_\_

(please specify)

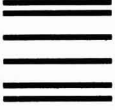

NO POSTAGE  
NECESSARY  
IF MAILED  
IN THE  
UNITED STATES

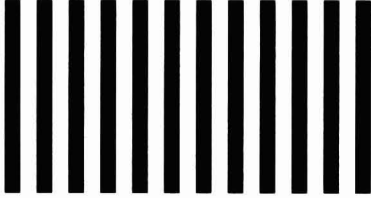

**BUSINESS REPLY MAIL**  
FIRST CLASS PERMIT NO. 1791 WACO, TX

POSTAGE WILL BE PAID BY ADDRESSEE

**Stevens Publishing**  
**Environmental**  
**PROTECTION**  
Reader Service  
Management Department  
P.O. Box 2573  
Waco, TX 76702-9910





# Only Nature could create a better eating machine.

Let one of America's largest mobile shredders take on your waste reduction problem.

In just an hour, it shreds 300 55-gallon drums filled with

solid waste. Or 40 tons of other solid waste. 400 washers and dryers. Or 2,400 car tires.

Whatever's in your way, we have an appetite for it.



*We'll take on anything  
that gets in your way*

(314) 647-8338  
P.O. Box 15191  
St. Louis, MO 63110

EPA-APPROVED CONTRACTOR • CONTAINER DISPOSAL • HAZARDOUS WASTE REMOVAL • VOLUME REDUCTION • RECYCLING • TANK CLEANING

Circle 11 on card.

# HERE'S A PLUG FOR BADGER RECORDALL® DISC METERS.



**Badger Meter, Inc.**

THE LEADER IN METER READING TECHNOLOGIES.

4545 W. Brown Deer Road  
P.O. Box 23099  
Milwaukee, WI 53223-0099  
414-355-0400  
Toll-free 1-800-633-0986

Circle 12 on card.

We have the solution to help reduce your operational costs. Optional 1-inch test plugs on our 1½" and 2" meters. Put an end to removing and reinstalling meters during field accuracy and pressure testing. Put us to the test. For all the facts, call our toll-free number or see your Badger Meter representative today.

Member AWWA, AMRA and NRWA



An independently owned American company.

Cover:  
Look on page 20  
to see how the  
Clean Air Act  
Amendments  
will affect your  
business in 1995.

Photo ©Tony Craddock,  
Tony Stone Images.

# Environmental PROTECTION

## FEATURES

- 15 Options For Gas Flow Measurement**  
By Paul S. Farber
- 20 Air Compliance Goals To Crystallize In 1995**  
By Kenneth A. Reich
- 28 TSDf Site Selection: A Three-model Approach**  
By Mark A. Finkelstein
- 37 Direct Push Technology: Concept Comes Of Age**  
By Richard D. Saunders
- 40 Bringing Together Pictures And Words**  
By William Douglas
- 45 In-Line Flow Control Blocks Risky Leaks**  
By William A. Nolan
- 60 Methyl Bromide Users Search For Science**  
By Eric D. Winegar
- 67 1995 Buyer's Guide**
- 138 1994 Editorial Index**

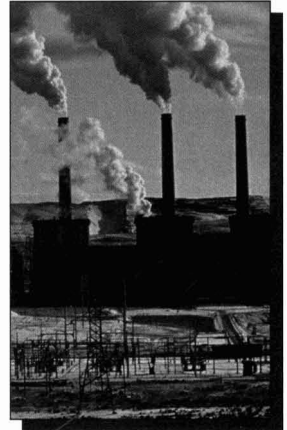

Page 20

## DEPARTMENTS

- 6 From the Editor**  
By Lisa K. Neal
- 8 News Update**
- 13 Viewpoint**  
By Carol M. Browner
- 26 Legal Watch**  
By Bert Black
- 50 Technology Answers**  
By Terri Rayer
- 53 Training**  
By Michael Cherniak
- 137 Product Literature**
- 146 Products & Services**
- 150 Classified Ads/Professional Directory**
- 162 Ad Index**



# From The Editor

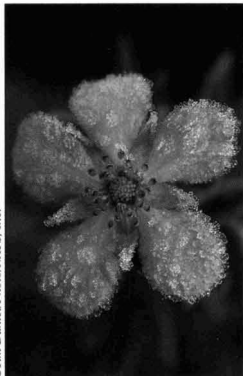

©Tim Daniel/PhotoNATS, Inc.

Definitely a keeper.

I'm not referring to your spouse or the sockeye salmon you wrestled with in Alaska. I'm talking about the issue you are reading.

Let's be honest. You don't always keep your copy of *Environmental Protection* handy. Once you've scanned the ads and table of contents, you look for the articles that have personal value. If you get the chance to read those, then the magazine may be sent to a colleague or tossed onto an already crowded bookshelf—never to be seen again.

Well, don't do that this month. Keep the January *Buyer's Guide* within reach. It will save time and prevent aggravation later.

I receive numerous calls during the year from readers seeking, for example, a list of companies that provide water disinfection equipment or hazardous materials monitoring systems. Or, they want to know if a particular firm known for its groundwater treatment services also can perform well in recycling matters. As if by magic, I am able to answer their queries in the few minutes it takes to pull my *Buyer's Guide* from the desk, turn its pages and remember the alphabet.

Aggravation comes when a reader is not sure what information he or she needs. Yes, I can mail a copy of the *Buyer's Guide*, but the information is sometimes needed for a meeting in 20 minutes. I could photocopy and send by facsimile the 50 pages, but I'm confident that the enterprise is too costly in time and fax paper.

The phone call is unnecessary if you save the issue.

Turn to page 67 and you will find roughly 475 products and services headings, 1,260 company profiles and the annual meetings directory. These were gathered over a four-and-a-half-month period and put into this easy-to-read format through the efforts of 18 Stevens Publishing Corp. employees.

Leading the charge was Shae Dickey, EP's sourcebook coordinator, who mailed invitations to the respective companies. The listings are free to those who fill out the forms—properly. Legibility is key. Shae, who has been putting the *Buyer's Guide* together since its inception in 1991, has seen the most unusual ways to write the number seven. She also has welcomed positive feedback from participants and suggestions for expanded subject headings as the market for environmental technology grows.

We invite you to share *your* ideas about how we might improve this reader service. Please write to me at EP Buyers Guide Suggestions, P.O. Box 2573, Waco, TX 76702.

*Lisa K. Neal*

## Environmental PROTECTION

Publisher, **Craig S. Stevens**

Corporate Editorial Director, **George M. Gold**; Managing Editor, **Lisa K. Neal**; Associate Editor, **Terril Rayer**; Editorial Assistants, **Jane Flores, David Garber**; Contributing Editor, **Whitman Bassow**

Advertising Production Managers, **Eliska Beaty, Cherie Chastain, Lori Witt**; Art Director, **Mylynda Callahan**; Production, **Donna Danna, Brenda Dennis, Regina Durham, Nancy Humphreys, Wendy Neumann, Jim Reeves**; Sourcebook Coordinator, **Shae Dickey**

U.S. District Sales Managers, **Ed Ambrose, Nick Kosan, Michael Wilson, Fran Zimniuch**; European Sales Manager, **Nick Jones** (Devon, England, phone: 44-626-854622; fax: 44-626-854644); Classified Sales Manager, **Stan Pruitt**

Classified Sales Representative, **Linda Flores**; National List Manager, **Ron Hunn**; District List Manager, **Tony Williams**; Circulation/Marketing Manager, **Mark D. Rathe**

President, **Craig S. Stevens**; Vice President, Finance, **Doug Mann**; Vice President, Operations, **John Anzelmo**; Vice President, Sales, **Jennifer Bartel**

### Editorial Advisory Board

**Bert Black, Esq.**, Weinberg & Green, Baltimore, Md.; **Gregory G. Bond, PhD**, Senior Manager, Environment, Health & Regulatory Affairs, Chemicals and Performance Products, The Dow Chemical Co., Midland, Mich.; **Rupert Burtan, MD**, President, TRI-DEM Services Ltd., Denver, Colo.; **Charles W. Calmbacher, PhD**, President/Principal Scientist, SEA Group Inc., Lawrenceville, Ga.; **Ann N. Clarke, PhD, CET, REA**, Director, Remedial Technologies Development Division, Eckenfelder Inc., Nashville, Tenn.; **Donald A. Deieso, PhD**, President/CEO, Metcalf & Eddy Cos., Somerville, N.J.; **Mark S. Dennison, Esq.**, Dennison Legal Services, Ridgewood, N.J.; **Paul Farber**, Project Manager, Argonne National Laboratory, Energy Systems Division, Argonne, Ill.; **Theodore A. Fischer II**, Business Manager, Du Pont Environmental Treatment, Wilmington, Del.; **Brian Hemphill**, Project Manager, Lambier Professional Group Inc., Portland, Ore.; **Robert C. James, PhD**, President, Toxicological Evaluations Research and Risk Assessment (TERRA), Tallahassee, Fla.; **Lawrence H. Keith, PhD**, Principal Scientist, Radian Corp., Austin, Texas; **Roger J. Marzulla, Esq.**, Akin, Gump, Strauss, Hauer & Feld, Washington, D.C.; **Gregor I. McGregor, Esq.**, McGregor & Shea, Boston, Mass.; **Marty Melton, CSP, CSE**, Division Program & Process Safety Manager, American NuKEM, Rock Hill, S.C.; **Barbara J. Mickelson, PE**, President, Acton, Mickelson, vanDam Inc., El Dorado Hills, Calif.; **Timothy J. Mohin**, Staff Member, Senate Committee For Environment and Public Works, Washington, D.C.; **Michael Naughton, Esq.**, Kummer, Knox, Naughton & Hansbury, Parsippany, N.J.; **Margaret C. Samways**, Senior Program Manager, Brown & Root Environmental, Pittsburgh, Pa.; **Richard C. Scherr**, Vice President, Environment, Health & Safety, Chemical Waste Management, Oak Brook, Ill.; **Chuck Schmidt, PhD**, Environmental Consultant, Red Bluff, Calif.; **George W. Siple**, Senior Air Quality Scientist, Camp Dresser & McKee Inc., Irvine, Calif.; **John R. Stukenberg, PhD**, Executive Partner, Black & Veatch, Kansas City, Mo.; **Richard J. Thompson, PhD, CIH, CSP**, Consultant, Harwood, Texas; **C. Joseph Touhill, PhD, PE**, Executive Vice President, EG&G Environmental, Pittsburgh, Pa.; **Susan Vogt**, Director, Environmental Policy, Training and Regulatory Affairs, Georgia-Pacific Corp., Washington, D.C.; **Phillip L. Williams, PhD, CIH**, Associate Professor, Environmental Health Science Program, University of Georgia, Athens, Ga.





## As The Largest Environmental Lab Facility In The U.S., We Can Handle Projects Of Any Size.

In the world of environmental analytical testing, few other labs can compare to Lancaster Laboratories. For over 30 years, we've been committed to providing the scientific talent, capabilities, and equipment to complete the most demanding projects accurately, responsively, and efficiently—even complex Superfund and RCRA projects. And our stringent SOPs and comprehensive laboratory management and quality systems ensure that we provide our clients with consistent, complete, and legally defensible data.

We have an experienced staff of over 300 scientists and technicians with expertise in all areas of environmental science. Over 85,000 square feet of modern facilities. And more than 5,000 available procedures to handle your analytical needs in air toxics, ambient air, indoor air, soil, water, wastewater, solid

waste, and hazardous waste testing. We'll assign a dedicated client services representative to your project for accountability. Maintain a clear chain of custody for your samples. And we'll meet your timetables.

So, for your next environmental project—no matter how demanding—choose Lancaster Laboratories. Sixty Fortune 100 companies and over half of the largest 100 environmental consulting and engineering firms in the country already have. And we'd be glad to show you why.



**Lancaster Laboratories**

*Where quality is a science.*

2425 New Holland Pike • Lancaster, PA 17601 • 717-656-2301 • Fax: 717-656-2681

Member: American Council of Independent Laboratories, Inc. Qualifications include EPA-CLP, AZLA, AIHA, Army Corps of Engineers, NEESA, and AFCEE.

Circle 14 on card.

## Correction

EPA's VISITT 3.0 database, as reported in the November 1994 issue of *Environmental Protection*, is limited to remediation and analytical technologies. Linda Fiedler is EPA project manager for the database and is not employed by PRC Environmental Management.

## Businesses, Regulators Settle Superfund Claim

EPA, the Department of Justice (DOJ) and Connecticut have settled with the largest ever group of parties under Superfund, with 837 businesses ordered to pay a total of \$6.7 million for cleanup of a solvents recycling facility in central Connecticut. The agency estimated that 86 percent of the eligible parties are participating in the settlement. This case represented the highest percentage and the largest number of small parties ever to settle with the agency and the DOJ.

Solvents Recovery Service of New England ran the recycling facility in Southington. Spent solvents used for degreasing and other purposes were shipped there by about 1,650 businesses between 1955 and 1991. The 3.5-acre facility was designated a Superfund site in 1983 because of soil and groundwater contamination from site operations.

The "early *de minimis*" settlement with the companies shipping smaller amounts of waste requires lump sum cash payments based on the amount of waste each settling party sent to the site. Each one shipped 10,000 gallons or less and will pay about \$3.50 a gallon and a \$1,000 fee. Each party agreeing to the *de minimis* settlement will resolve its liability at the site and will be protected from third-party lawsuits.

The \$6.7 million will be used to reimburse the agency and Connecticut for past site-related costs and to help finance the cleanup by other liable parties or the government.

## Submersible Pumps Not Leaching Lead

Significant levels of lead are probably not leaching into groundwater supplies from submersible well pumps operating under typical installation conditions, according to a study recently released by the University of North Carolina-Asheville's Environmental Quality Institute.

The EQI study supports information gathered by the National Groundwater Association from several state agencies that had measured lead levels in active drinking water wells.

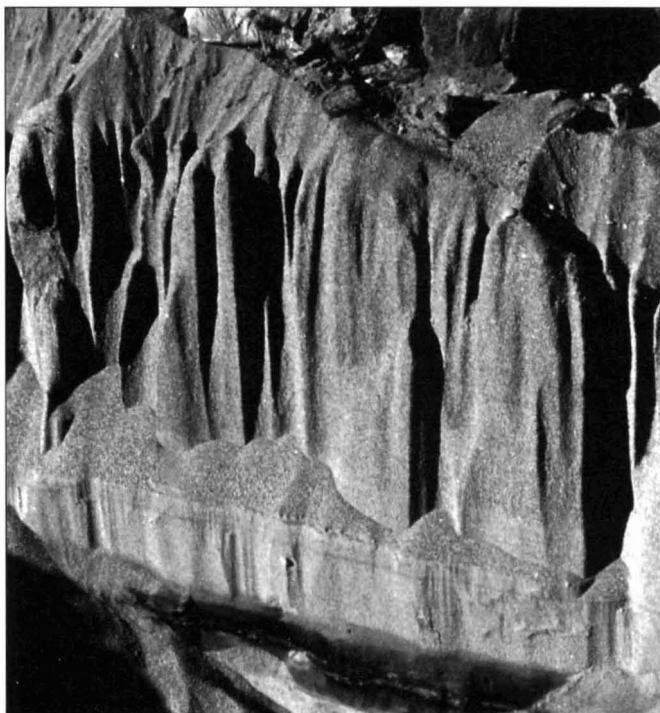

*Montan Wax in the subsurface. The wax in the subsurface was colored for different phases of resting. Photo courtesy of Mary Peterson, Program Coordinator.*

## Prehistoric Wax Poses Possible Barrier To Toxic Materials

The U.S. Department of Energy is conducting tests on a prehistoric wax that may prove useful as a barrier to inhibit the flow of contaminants through soil.

Montan wax, approximately 250 million years-old, can be found in coal deposits in eastern Germany and northern California and has been used in highway construction materials, building supplies, carbon paper and furniture polishes.

Carl Einberger, DOE's technology developer, said the substance is "particularly hard for a wax," an attribute which enhances its use as a barrier. The montan wax permeates and bonds the soil together when injected.

Researchers conducted permeability tests in a site near Richland, Calif., where they injected the montan wax into subsurface material. The wax was injected using the same process used for cement- and plastic-based sealants.

According to Einberger, only minute portions of water could travel through the barrier because the wax was able to permeate the soil and block porous spaces. He said the Richland site will be excavated in the spring to reveal possible permeability reductions.

Montan wax favors comparably to other subsurface sealants, Einberger said. For example, sodium-silicate sealants have the propensity to shrink; consequently, they tend to crack. An advantage to the wax is that it expands and contracts with seasonal changes without cracking, according to Einberger.

Researchers have conducted "chemical compatibility tests," Einberger said. Small portions of soil bonded by the montan wax were directly placed into contaminants with favorable results.

The DOE performed initial testing of montan wax last year at Sandia, New Mexico, which indicated the success of montan wax in coarse soils.

Program Director Mary Peterson said, "If proven successful, (montan wax) could be used to create a temporary barrier around holding tanks, landfills or contaminated soils."

*—By David Garber, editorial assistant.*

# Test Your Strength.

•  
**The Strength Of  
Your Safety Program  
Is The Strength Of  
Your Company.**  
•

Test the strength of your workforce's safety knowledge thoroughly, accurately, simply and quickly with the **WORKSAFE Assessment Program**. The most powerful testing tool available.

•

The WORKSAFE Assessment Program pinpoints your employees' strengths and identifies additional training needs. The WORKSAFE Assessment Program eliminates wasted time, wasted effort and wasted money. The system provides automatic results for competency reviews.

Features include:

- Easily customized pool of questions
    - Automatic documentation
    - Runs on any PC or network
    - High-resolution color graphics.
- 

Test the strength of your safety compliance program. Call marketing services at 1-800-324-2744 to learn more about the cost saving benefits of the WORKSAFE Assessment Program.

**WORK SAFE**<sup>™</sup>  
KNOW IT, PROVE IT.

Williams Knowledge Systems, Inc.  
One of The Williams Companies, Inc.  
One Williams Center / Tulsa, OK 74172  
©1994 Williams Knowledge Systems, Inc.

Circle 15 on card.

# NEWS UPDATE

Measurements for lead levels in the water were taken from wells constructed near Asheville specifically for the institute's study, with one of five brands of submersible well pump installed in each well.

Two of the five brands "produced essentially undetectable lead concentrations throughout the study," while the other brands had average lead levels in each of eight five-day intervals readily below the 15 parts per billion action level for public water distribution systems.

## Groups Volunteer To Control Groundwater Petroleum

Five northwest Indiana corporations signed a voluntary agreement with EPA and the Indiana Department of Environmental Management to control the migration of petroleum distillates floating on top of groundwater. Millions of gallons of the floating oil, called free-phase hydrocarbons, are estimated

to be underground.

During heavy rains and other weather conditions, these hydrocarbons migrate into the Indiana Harbor and Ship Canal and, ultimately, Lake Michigan. Companies signing the agreement are Amoco Corp., Mobil Oil, Northern Indiana Public Service Co., Phillips Pipeline Co. and Safety-Kleen Corp., all of whom agreed to monitor their properties to determine if free-phase hydrocarbons are migrating from groundwater to surface water. If so, they have agreed to construct a barrier or a collection system to stop it. EPA will provide technical assistance in implementing this agreement and monitor progress.

## BIF Facilities Face Enforcement Action

EPA announced 32 enforcement actions involving \$7.5 million in penalties against owners and operators of incinerators, boilers and industrial furnaces that burn hazardous wastes. The operators were charged under the Resource Conservation and Recovery Act (RCRA) in Georgia, Michigan, South Carolina and Utah.

Twenty-two of the cases involved civil penalties while 10 cases involved administrative complaints. "Reducing human health and environmental risks by hazardous waste combustion remains a top EPA priority," said EPA Administrator Carol Browner. According to Browner, this is the third enforcement action since the Boilers and Industrial Furnaces Rule became effective in August 1991. The operators allegedly violated regulations concerning feed rates and emissions standards, operating without automatic waste feed cutoff systems and not properly analyzing wastes prior to combustion.

## Agency Addresses Public Health With Rule

A final rule requiring air-tight covers and vapor control devices for hazardous waste treatment, storage and disposal facilities is expected to reduce public health problems, especially cancer, said an EPA spokesman.

The covers and control devices will hold volatile organic compound emissions.

According to EPA, the Resource Conservation and Recovery Act rule will reduce cancer cases to only two per year. Approximately 48 cases per year would have occurred in the absence of the new rule, an agency spokesman reported.

The new regulation applies to 2,300 permit-

## Unipure Environmental Rewrote the Book on Metals Removal



Now it's yours...FREE!  
(800) 323-8647

Unipure Environmental would like you to have the facts on Metals Removal technology. Our FREE technical brochure explains how removing heavy metals from water can be done effectively with our proprietary process.

This unique, patented technology removes a broad range of heavy metal contaminants more efficiently than any other treatment system. We can deliver a water treatment system for any flow rate, from small daily batches to thousands of gallons per minute that will

be guaranteed to meet your compliance requirements.



Unipure has been a leader in metals removal technology since 1984. While continuing to

develop new treatment technologies, we are teaming with innovative environmental firms to better serve our customer's needs. We believe our new name, Unipure Environmental, reflects this vision and commitment.

Call us to discuss how we can apply our expertise to your treatment needs.



UNIPURE ENVIRONMENTAL

(714) 447-5500 • Fax: (714) 447-5508  
1511 East Orangethorpe Ave., Fullerton, CA 92631

UNOCAL 

ted RCRA facilities. A projected 20,000 hazardous waste generators also will be affected as the rule is applied to generator tanks and containers used in the storage of hazardous waste.

EPA estimates a capital investment of approximately \$290 million and annual costs of \$110 million. Despite the cost for compliance, EPA expects price increases to be "substantially" less than 1 percent.

## Food Safety Compels Pesticide Regulation

EPA is proposing actions to regulate genetically introduced pesticide substances in plants. The substances, originating from bacteria, insects, viruses, animals or other plants, are deliberately introduced into vegetation so plants can be engineered to produce the substances themselves. Genetically introduced substances have the advantage of reducing pesticides because the plants produce them internally.

EPA, however, is planning to evaluate plant-pesticides posing new exposures. The agency may exempt those plant-pesticides derived from a closely related plant, those that act by strengthening the plant's defense mechanisms without affecting non-target organisms, and coat proteins from plant viruses.

## Agency Lightens PCB Regulation Load

EPA has proposed amendments to polychlorinated biphenyl, or PCB, regulations that could reduce industry costs by \$2 billion to \$6 billion per year. The proposed rule would:

- Provide flexibility in selecting disposal technologies for PCB wastes and expand the list of prescribed, self-implementing decontamination procedures;
- Provide less burdensome mechanisms for obtaining agency approval for a variety of activities;
- Clarify ambiguous regulations;
- Modify requirements for the use, maintenance, commercial distribution and disposal of PCB equipment; and
- Address issues of notification and manifesting of PCB wastes.

The rule provides for improved coordination of PCB waste management activities under the Toxic Substances Control Act with those under other federal and state authorities. It also will delete a number of outdated requirements, and make certain policies and regulations consistent with the requirements of other federal statutes.

## Council Ranks Top Corporate Polluters

The Council on Economic Priorities (CEP) listed Union Carbide as the top offender on its roster of America's worst corporate polluters. Among other companies named were Exxon, International Paper, Southern Companies,

Texaco, Westinghouse, Westvaco and, for the third year in a row, MAXXAM, a lumber, aluminum and metal products manufacturer.

CEP, the New York-based non-profit organization known for its book series, "Shopping for a Better World," researches corporate social and environmental responsibility.

*continued on page 145*

I N T R O D U C I N G

# ENERAC™ 3000 SEM

**The new generation of compliance-level emission analyzers with advanced SEM™ SENSORS & DOCUMENTED QUALITY ASSURANCE.**



- NOX RACT
- Audits
- CEMS Backup
- Operating Permits
- Emission Rates
- Enhanced Monitoring

ENERAC 3000SEM offers facility managers an easy-to-use, cost-effective method for establishing a comprehensive and reliable, Quality Assured Emissions Database (NO, NO<sub>2</sub>, NO<sub>x</sub>, SO<sub>2</sub> and CO data) that meets EPA (proposed) enhanced monitoring measurement requirements for CAAA Title V Permits.

- Advanced SEM Sensors
- QA/PCM - Quality Assured Precision Control Modules
- QA/PCM - Quality Assured Interference Protection
- Integrated Sample Conditioning
- QA/CCP - Quality Assured Calibration Certification Protocol



MADE IN USA

**For the information you need today, call 800-695-3637**

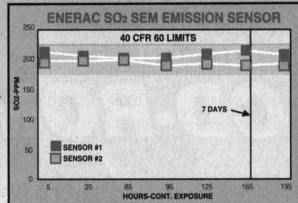
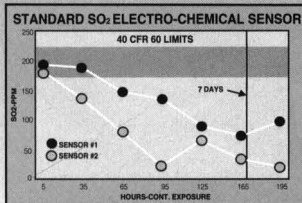

Truly continuous operation. No periodic purging. 40 CFR 60, Appendix B, Spec 2. 7 day Calibration Drift Test.



1300 Shames Drive, Westbury, NY 11590  
(516) 997-2100 • 800-695-3637 • Fax: (516) 997-2129

ENERAC & SEM are trademarks of their respective companies. Compliance level tests are source specific.

# S:f(T)

## Solutions are a Function of the Tools You Use

If you make a living solving environmental compliance problems, you need the right tools. You need the Stevens Environmental Sourcebook.

The Stevens Environmental Sourcebook provides the industry's most accurate, most complete, most up-to-date source of supplier information. From Absorption Equipment to Wastewater Treatment Equipment and 472 headings in between, you'll find the resources you're looking for in the Sourcebook.

But the Sourcebook is more than just a directory. It's a valuable tool designed specifically for environmental control professionals. There are 13 easy to use sections with alphabetic, geographic and product indexes. Insightful commentaries from industry leaders. There's even a government index with information on where to go for answers.

When published in February, the Sourcebook will sell for only \$99. But, if you reserve a copy now, you can take advantage of the special pre-publication discount and pay only \$59 (plus \$2.50 postage/handling).

**That's a savings of 40%.**

For information on a free listing or to reserve a copy of the Sourcebook, call or mail to: The Stevens Environmental Sourcebook, P.O. Box 2573 Waco, TX 76702-2573.

Add sales tax in TX, DC, IL, KS, MI, MN, NJ and WI.

# 1(800)727-7573

THE  
STEVENS  
Environmental  
SOURCEBOOK

Circle 18 on card.

Available on  
**CD-ROM**

Stevens Publishing Corporation also publishes *Environmental Protection*, *Occupational Health & Safety*, *Environmental Protection News*, *Hazmat News*, *Waste Management News*, and *Water Pollution Control News*.

# Browner Pledges Common Sense Approach

Over the past generation, the U.S. Environmental Protection Agency has overseen a remarkably successful effort to protect public health and our natural resources.

To take two visible measures of success, we no longer have rivers catching on fire and our skies are cleaner. Yet much remains to be done.

To find common-sense, cost-effective solutions to environmental problems, the Clinton Administration has launched a new generation of environmental protection to safeguard public health and our natural resources in communities across the country.

EPA's Regulatory Plan for 1995, which appeared in the *Federal Register* on Nov. 14, 1994, is part of our effort to achieve the very best environmental results in the most cost-effective manner. When possible, EPA seeks non-regulatory solutions that will achieve environmental goals. When regulation is required by either law or circumstance, we seek to work with our partners in state and local governments and with environmentalists, industry and other affected parties to ensure that those who must live with environmental decisions have every opportunity to help make those decisions.

The agency is continuing to explore using market-based means, where legal and appropriate, to achieve environmental ends.

And, we are committed to making our rules more concise and understandable.

## EPA'S Common Sense Initiative

Through EPA's new Common Sense Initiative, the agency and outside groups will work together to replace the pollutant-by-pollutant, "one-size-fits-all" approach of the past with an industry-by-industry approach for the future. By arriving at a blueprint for environmental protection that is tailored to a particular industry as a whole, we expect to achieve better environmental results while saving billions of dollars.

For each of six initial industries, state and local government officials, environmentalists and industry leaders will work together to help EPA find ways to make environmental protection work "cleaner, cheaper, and smarter." We will take a fresh look at regulatory requirements that may be duplicative, burdensome or unnecessary. Where possible, we will seek to coordinate regulations that pertain to air, water and waste; prevent pollu-

tion rather than simply waiting to clean it up; promote the use of innovative technology; and improve record-keeping requirements.

## Strategic Themes

In the coming year, the following strategic themes will guide our rulemaking concerning accident prevention, public reporting, drinking water safety, combustion and waste minimization, clean air, pesticide risk reduction and other areas:

**Ecosystem Protection:** Too often in the past, environmental regulations had the inadvertent effect of simply shifting and shuffling pollution – from air, to water, to land. To move beyond this piecemeal approach, we are committed to using comprehensive regulatory approaches whenever possible – approaches that recognize that nature is a system.

**Environmental Justice:** Some communities bear a disproportionate burden of pollution. We are committed to ensuring that every community is protected.

**Pollution Prevention:** Common sense dictates that preventing pollution in the first place is more efficient than cleaning it up after the damage has been done.

**Better Science and Data:** We are committed to obtaining clear, well characterized information about environmental problems and their potential solutions.

**Environmental Partnerships:** EPA will work with other federal agencies, states, municipalities, and individual citizens toward our environmental goals.

**Enforcement Accountability:** EPA recently reorganized our enforcement effort to assist business in complying with environmental laws while at the same time taking strong action against those who violate those laws.

The new generation of environmental protection means finding common-sense, cost-effective solutions to environmental problems – solutions that work for communities across the country. The regulation agenda of the Environmental Protection Agency for 1995 is reflected throughout.

*Carol Browner is administrator of EPA, which celebrates its 25th anniversary this year. She is an attorney who has been active in the environmental arena since 1983. She has been credited with tightening control on hazardous waste incinerators and proposing reforms on Superfund, the Safe Drinking Water Act and the Clean Water Act.*

*"Only Counterpoint gives you all the regulations you need on CD-ROM or the Internet."*

Call Now for  
Free Demo CD-ROM!

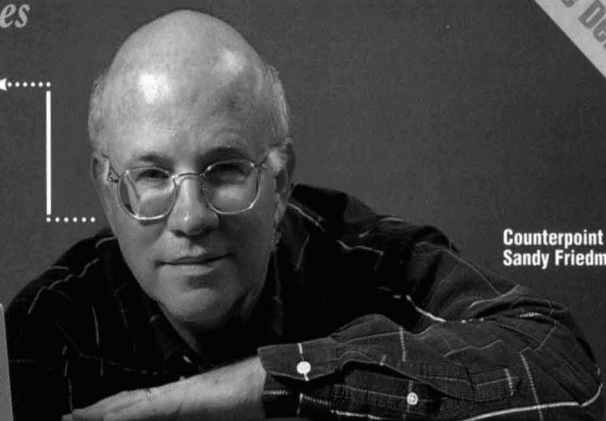

Internet

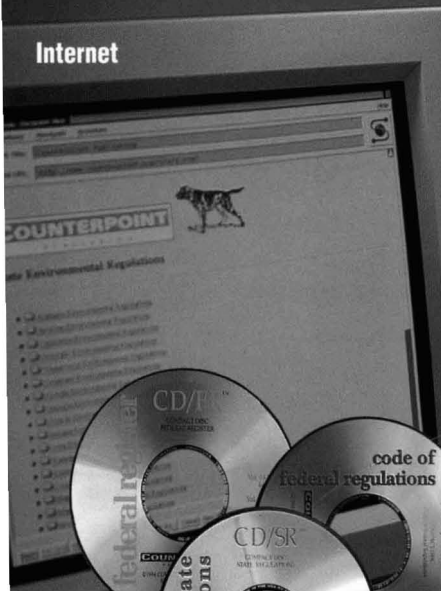

DOS



Windows/Mac

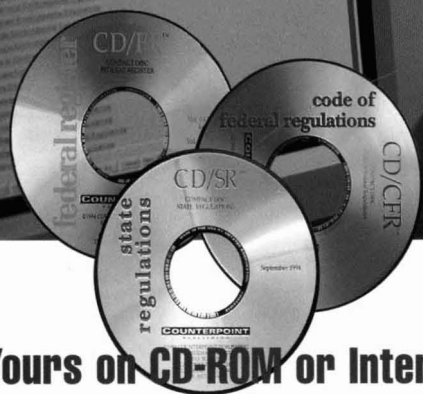
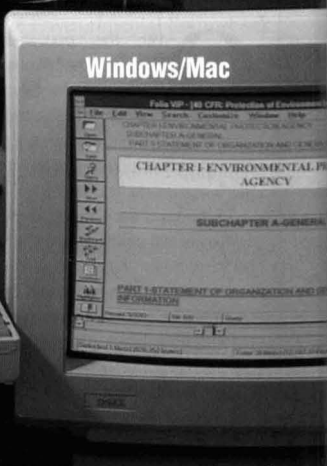

**Yours on CD-ROM or Internet:  
The most complete, accurate,  
and timely versions of**

**Code of Federal  
Regulations  
Federal Register  
State Environmental  
Regulations**

**and more**

**(800) 998-4515**

## The Professionals' Choice in Environmental Software

**C**ounterpoint is the first choice of professionals who need accurate, complete, and current regulations on CD-ROM. That's because Counterpoint delivers regulations the way professionals want them: on desktop PCs, over local and wide-area networks, or even over the Internet (a Counterpoint exclusive). Today's professionals demand electronic databases that give them the right regulations quickly. They demand the

choice of DOS, Windows, or Macintosh with unlimited toll-free support and without costly upgrade charges.

See for yourself why Counterpoint's regulatory products are used by more corporations, consultants, and government agencies than any others. Make sure you are not paying way too much for far too little.

*Call for our free demo CD-ROM today. Ask about our 30-day risk-free trial.*

**Circle 19 on card.**

**COUNTERPOINT**  
PUBLISHING

84 Sherman Street, PO Box 928, Cambridge, MA 02140  
Tel: (617) 547-4515 Fax: (617) 547-9064 email: info@counterpoint.com



# Options For Gas Flow Measurement

*Which system is best for your facility depends on gas stream conditions, plant maintenance and duct or stack design.*

By Paul S. Farber

**T**o remain in compliance with provisions of not only the Clean Air Act but state and local emissions regulations as well, it is necessary for operators to know the volume of their facilities' gaseous emissions.

This is especially true under Section 112 (Hazardous Air Pollutants) of the Clean Air Act (CAA) where the emphasis on industry is to reduce the total mass emissions of one or more of the regulated compounds. Industry has resorted to at least one of the following approaches to determine a facility's emissions:

- material balances,
- emission factors,
- monitoring and measurement.

In the material balances approach emissions can be determined by careful review of an incoming material flow (either as a raw material or as a contaminant in a raw material), determining how much of the material leaves as product, air or water discharge based on an engineering review of the process, and careful calculations.

Using emission factors (as, for example, those published by EPA in AP-42 "Compilation of Air Pollutant Emission Factors"), a specific emission is calculated based on the measurement of a process variable (such as the federate of coal to a boiler), coupled with a process measurement (the sulfur content of the coal being fed), and an emission factor which has been carefully determined (amount of sulfur dioxide emitted/sulfur/ton of coal).

Finally, monitoring and measurement of a pollutant concentration can be relatively routine (for example, for carbon monoxide or sulfur dioxide) or complicated, depending upon the compound being detected. But monitoring the concentration is only half the story, because to calculate a mass emission, it is important also to know the emission gas flow rate. This emission is measured

with a gas flow rate sensor which is an integral part of the Continuous Emissions Monitoring System (CEMS).

**Placement of the CEMS** — The location of a CEMS, and especially the flow rate monitoring system, is specified in the Code of Federal Regulations (40 CFR 60 Appendix A) to ensure proper streamline flow and reliably measure gas flow. The regulations specify that the measurement location should be at least eight duct (or stack) diameters downstream from the last flow disturbance (a change in direction, entrance or exit) and at least two diameters upstream from any similar disturbance.

Placement of a gas flow rate measuring device in a turbulent flow area may give readings that are unstable and as likely to improperly read high as they are to read low. Therefore, it is important that a stable location be planned for in a new installation or in an existing facility.

**Types of Flow Rate Monitors** — There are three basic types of devices used for measuring gas flow in process plants: differential pressure; ultrasonic and thermal.

Differential pressure flow meters, as their name implies, utilize the differential between the static and dynamic pressure measurements to calculate the gas flow rate. These devices are quite similar to the gas/particulate probe used in manual gas sampling (40 CFR 60 Appendix A, Method 5), and the measurements are based on the same calculations.

The construction of a differential pressure flow meter includes a probe which, in general, spans the diameter (or width) of the area to be measured, a series of sharp-edged dynamic pressure ports on the downstream side of the probe, and a sharp-edged orifice on the upstream side for the static pressure port.

Precise placement of the probe so that the dynamic pressure ports are exactly perpendicular to the direction

*Paul Farber is project manager at Argonne National Laboratory's Energy System Division in Argonne, Ill., and a member of EP's editorial advisory board.*

of flow is crucial. In a streamline flow area, the highest velocity tends to be near the center of the duct and the lowest at the walls (theoretically the velocity at the walls is zero), and so the multiple ports on the downstream side of the probe are important so that the average flow rate across the duct diameter/width is measured. A differential pressure measurement is used to calculate the velocity using the equation:

$$\Delta P = P_i - P = (1/K_p^2 C_p^2) V_i^2 (P_s M_s / T_s)$$

where  $P$  = pressure,  $\Delta P$  is the differential between the static and dynamic pressures,  $P_i$  is the dynamic pressure measured at point  $i$  on the probe,  $K_p$  is the orifice coefficient of the ports,  $C_p$  is the specific heat of the gas (as determined from information supplied by the user),  $V_i^2$  is the gas velocity at the  $i$  pressure port,  $P_s$  is the absolute pressure in the stack or duct at the point of measurement,  $M_s$  is the molecular weight of the gas (as determined from the information supplied

by the user), and  $T_s$  is the absolute temperature of the gas at the point of measurement.

In some probes, the dynamic pressure ports are mounted in a single chamber so that an average dynamic pressure is seen at the end of the probe. Probes that measure each individual port must calculate a velocity of the gas at each point and use these to determine the average velocity by:

$$V^2 = (1/n) \sum V_i^2$$

where  $n$  is the number of dynamic pressure points and  $V_i$  is the velocity calculated from each of the individual pressure measurements.

Once the average velocity is known, then the total gas flow (in standard cubic feet per minute) can be calculated by the equation:

$$W = AV(T_{STD} P_s / T_s P_{STD})$$

where  $W$  is the mass flow rate,  $T_{STD}$  and  $P_{STD}$  are the standard temperature (60°F), and pressure (1 atmosphere), and  $A$  is the cross sectional area of the duct or stack at the point of velocity measurement.

Differential pressure monitors are usually rugged in construction and fairly economical; manual versions are advertised for \$100. But they have the disadvantage of being interfered with by particulates and liquid droplets. Consequently, it is advisable that these be placed after particulate control equipment and demisters for successful long-term operation.

Ultrasonic flow rate monitors use ultrasonic transceivers mounted at an angle across the duct or stack to measure the average flow velocity. An ultrasonic burst is sent from the upstream transceiver to the downstream transceiver and the transit time at the speed of sound is measured between units. Next, another burst is sent from the downstream transceiver to the upstream transceiver and another transit time is measured. Subtracting one set of measurements from the other average velocity is:

$$V = (L/2 \cos \alpha) [(1/t_1) - (1/t_2)]$$

where  $L$  is the distance between transceivers,  $\alpha$  is the angle between the transceivers, and  $t_1$  and  $t_2$  are the transit times and the volumetric flow rate is calculated using the same formula as is used for the differential pressure measurement.

Since ultrasonic velocity sensors measure the average velocity in their path length, it is important that a proper sampling location be chosen since an extreme velocity profile, or an area of gas swirling, will produce erroneous results. As with the differential pressure monitor, the ultrasonic monitors can have their reading interfered with by liquid droplets and by particulates, and it is necessary also to monitor the temperature and

## Complete Lift Station Control.



### Non-contacting, ultrasonic measurement and a full range of pump control features make the HydroRanger I the choice for total lift station control.

The maintenance-free HydroRanger I is easy to install and uses the newly designed ST-H transducer and state-of-the-art echo-processing technology to provide the accuracy and reliability you expect from Milltronics.

The HydroRanger I costs less to install than floats, bubblers and differential pressure systems. And because the HydroRanger's transducer is mounted above the surface of the wastewater, there is no need to empty or enter the wetwell during installation.

#### Advantages of the HydroRanger I:

- Measurement range of up to 33 feet
- Accuracy to + 0.25%
- Built-in relays control on/off cycles for up to five pumps.
- Controls pump alternation, lead/lag, and other automatic pump cycles
- Totalizes lift station volume throughput and logs pump run times
- Removable programmer eliminates need to open enclosure to calibrate.
- Enclosure provides corrosion protection.

**For a detailed brochure or personal demonstration, call (817) 277-3543 or fax (817) 277-3894.**

 **MILLTRONICS**

709 Stadium Drive East  
Arlington, Texas 76011-9870

# Contaminated Soil/Water? Clean it! Don't Haul it!

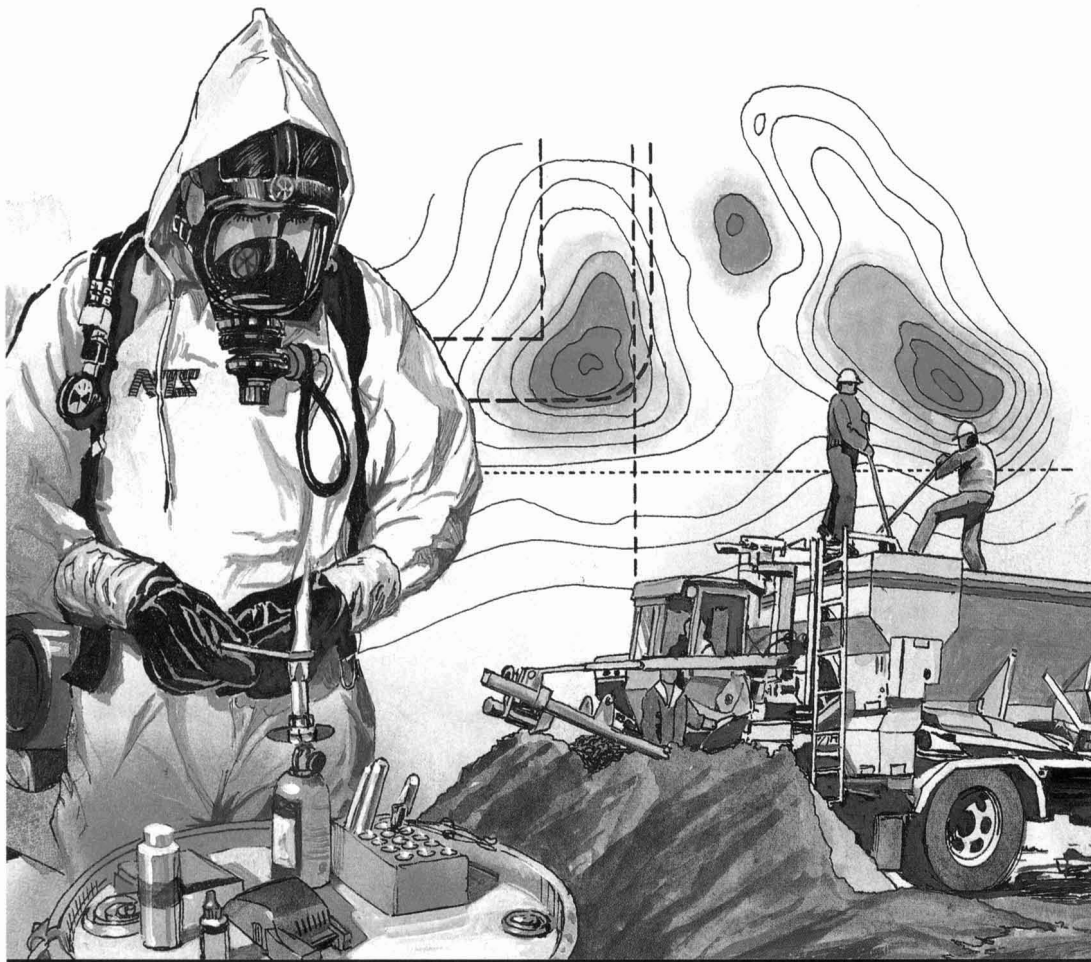

## Why Transplant The Problem?

We offer the most cost-effective remediation techniques in the industry. And we guarantee regulatory compliance on all our jobs. We employ the latest in remediation techniques including advanced methodologies for hydrocarbon and heavy metals-contamination removal. And they are all field-proven solutions.

Keep your plant operational and your bottom line healthy. Our in-situ methods are less disruptive and definitely more cost-effective than other alternatives. Call for a copy of our Statement of Qualifications or a site-specific quotation.

### Our remediation services include:

- Soil Wash
- Bioremediation
- Heavy Metals
- UST Removal
- Ordnance Disposal
- Radioactive Waste
- Stabilization
- Vapor Extraction
- Composting
- Ground Water
- Toxics
- Air Sparging



National  
Technical  
Systems

### Environmental Services

1536 E. Valencia, Fullerton, CA 92631  
714-879-6110 • Fax 714-449-0925  
**Toll Free 800-677-2687**

Circle 21 on card.

## WATER TREATMENT

### AIR STRIPPING

- Air Stripping Systems (1" thru 12' diameter)
- ShallowTray™ Systems
- Diffused Aerators & Blowers
- Packaged Treatment Systems
- Air Stripping Components and Internals
- Treatment System Controllers

### OIL/WATER SEPARATORS

- ERS Stainless-Steel Separators
- Hydro-Flo Fiberglass Separators
- ERS Low-Flow Skid System

### TANKS

#### PRETREATMENT

- Sequestering Agents
- Chemical Metering Pumps

### CARBON

#### BAG FILTERS

## PUMPING SYSTEMS

### RECOVERY PUMPS

- Pneumatic Platen Pumps
- Pneumatic Double Diaphragm Pumps
- System Controls

### SUBMERSIBLE PUMPS

- Electric Depression Pump Controllers
- Grundfos® Environmental Pumps & Motors
- Standard Grundfos® Pumps & Motors

### SAMPLING PUMPS

- Grundfos® Sampling Pumps & Controls

### MISCELLANEOUS AND SPECIALTY PUMPS

- Centrifugal Transfer Pumps
- Electric Diaphragm Pumps

## COMPRESSORS

### INGERSOLL-RAND®

### SAYLOR-BEALL

#### COMPRESSOR ACCESSORIES

- Dryers
- Auto-drains

## CONTROL SYSTEMS

### STANDARD & CUSTOM CONTROLLERS

- Rainight (NEMA 3R & 4)
- Explosion Proof (NEMA 7)
- Pneumatic (NEMA 4 & 4X)
- Programmable Logic Controls
- Auto-Dialers

### INTEGRATED CONTROL SYSTEMS

- Combination Air & Electric Controls

### SITE BOSS® REMOTE MONITORING

## VACUUM EXTRACTION SYSTEMS

### VES OPTIONS

- Regenerative Blower Systems
- Positive Displacement Systems
- Explosion-Proof Ventilation Systems
- VES Portable Pilot Test Units
- Skid, Trailer, & Enclosure Mounting

### REGENERATIVE BLOWERS

- Rotron Ex-proof EN Series
- Standard Rotron TEFC DR Series

### POSITIVE DISPLACEMENT BLOWERS

### ROTARY VANE VACUUM PUMPS

### VES ACCESSORIES

- Moisture Separators
- Air Filters
- Vacuum Relief Valves
- Instrumentation
- Flow Sensors and Indicators

## AIR SPARGING SYSTEMS

### SPARGING SYSTEM OPTIONS

- Positive Displacement Systems
- Rotary Vane Systems

### SPARGING ACCESSORIES

- Air Filters
- Pressure Relief Valves
- Flow Sensors and Indicators
- Instrumentation

## RENTAL SYSTEMS

### AIR STRIPPING

- ShallowTray™ Aerators
- Air Stripping Towers

### AIR SPARGING

#### RECOVERY SYSTEMS

- Pneumatic
- Auto-Skimmer

#### VACUUM EXTRACTION

pressure of the gas in the region of the probe to convert to standard conditions. Additionally, it is necessary to ensure that the "windows" through which the ultrasonic pulses pass remain clean so as not to diffuse or block the beams. Installation of a "blow-back" system similar to that used for continuous gas monitoring probes or frequent maintenance is highly recommended for the ultrasonic system.

Thermal flow monitors use heat transfer phenomena to determine velocity, and hence, the total gas flow rate.

In general, these monitors consist of a probe with two sensors mounted at the same point (Note: just like the differential pressure flow monitors, a large duct or stack may entail a design with several sensors mounted along the length of the probe to obtain an averaged reading). The first of these sensors is a quick response temperature sensor for monitoring the gas in the duct or stack. The second of these sensors is similar in construction to the temperature sensor and is called the mass, or velocity, flow sensor.

In operation, the temperature sensor detects the temperature of the gas flowing past it and attempts to keep the velocity or mass flow sensor at some fixed temperature (usually about 20 degrees C) higher than the surrounding gas temperature through an electrical current.

The gas flowing past the flow sensor will, through forced convection, attempt to cool the sensor down. The amount of power needed to maintain the elevated temperature within the sensor is used in a heat transfer equation that relates the velocity of the gas past the probe, the temperature difference between the gas and the sensor, and the gas viscosity, density and thermal conductivity to one another. The product from this equation is the gas velocity flowing past the sensor point.

A multiple sensor probe will perform these calculations for each of the points along the probe and develop the velocity and gas flow profiles and averages across the duct.

The advantage of the thermal flow monitor is the simultaneous monitoring of temperature and velocity in the same piece of equipment and the relative insensitivity to liquid droplets and particulates. The disadvantage of a thermal flow monitor is that the velocity calculation depends, to a great deal, on such factors as the gas viscosity and thermal conductivity. Because of this dependence, information on the composition of the gas stream must be given to the

probe manufacturer during the design phase, and it is recommended that these probes only be used in ducts or stacks with relatively constant compositions. Process exhaust ducts that combine compositions would not be good candidates for a thermal flow monitor. On the other hand, with their low maintenance requirements and quick response, these probes would be good for stable processes such as boilers or continuous dryers.

## Conclusion

Several methods exist for monitoring gas flow rates in ducts and stacks — differential pressure, ultrasonic and thermal monitors.

Differential pressure monitors have the advantage of being technology that is familiar, of simple construction, with a relative ease of installation. These probes have the disadvantage of increased inaccuracy at very low gas flow rates or in gas streams with high aerosol or particulate concentration, especially if particulates build up in a port.

Ultrasonic probes can be accurate over wide ranges of gas flows; they are non-intrusive in nature and they measure the velocity directly. On the other hand, ultrasonic monitors can have accuracy problems in regions of swirl or non-symmetrical temperature or flow regimes, have a fairly high capital cost and can have problems on installation if a 45 degree "view path" free of obstructions cannot be found.

Thermal monitors have the advantage of being fairly rugged, able to measure the flow at each sensing point to take into account any velocity profiles that exist, do not require a separate monitor for temperature measurement and are accurate over wide ranges of gas flows. The disadvantages of thermal monitors are their dependence on fairly constant gas flow composition, a necessity to ensure proper orientation in the gas flow, and a potential for the change in the readings over a period of time due to a buildup of material (fouling) on the outside of the flow sensor.

The choice of a flow monitoring system should be carefully made depending upon the gas stream conditions, the reliability of plant maintenance efforts and the duct/stack design or location. It is important for regulatory and process reasons to install and maintain an accurate and reliable gas flow rate monitor. Successful operation of such a monitor will not only result in continued compliance but will give the operator a better understanding of his process. **EP**



9 Dogwood Lane  
Middletown, PA 17057-0510  
800-944-5515  
717-944-4551 Fax

Environmental Restoration Systems, Inc.

**if** YOU'RE LOOKING FOR  
**reliable**  
ON-SITE  
**testing,**

**THIS WILL  
MAKE YOUR  
JOB A LOT  
EASIER.**



**D**TECH<sup>®</sup>  
Environmental Detection Systems

# D TECH environmental test kits

EASY ANSWERS.

Whether you're identifying hot spots, mapping sites, monitoring remediation, or screening field samples for laboratory analysis, D TECH environmental test kits make your job easier – and your results reliable.

## HOW RELIABLE?

D TECH kits are validated against standard SW-846 analytical methods for correlation, cross-reactivity, false negative/false positive rates, and performance using actual environmental samples. As a result, the EPA now accepts D TECH test kits for screening soil and water samples.

## NO EXPERIENCE REQUIRED.

You don't need any field testing experience or training. D TECH test kits include everything you need to detect sub parts-per-million (ppm) levels of target contaminants in soil and water samples.

And you certainly don't need a lot of time. With D TECH's *new Dual Particle Assay* method, you'll get reliable results in 15-20 minutes. So you save valuable time while reducing remediation and analytical costs.

## THERE'S A D TECH KIT FOR YOUR JOB.

A wide selection of D TECH test products makes it easier for you to find the kits you need. The D TECH product line includes kits for:

- ◆ TCE
- ◆ BTEX
- ◆ TNT
- ◆ PCB
- ◆ PAH
- ◆ RDX

And with the help of customers like you, we're continually learning new ways to improve our technology and expand our product line. As a result, you're assured of a steady stream of innovative D TECH test products in the future.

You're also assured of 100% satisfaction. In fact, it's guaranteed – and backed by a nationwide network of D TECH service and support specialists.

## WITH D TECH KITS, THE ANSWERS COME EASY.

If you're looking for answers to your on-site testing questions, call EM Science at **1-800-222-0342**, and ask about our EPA-accepted test kits. We'll show you how D TECH environmental test products make reliable on-site testing a whole lot easier.

EM Science  
Strategic Diagnostics, Inc.  
480 Democrat Road  
Gibbstown, NJ 08027  
800-222-0342

**D TECH**<sup>®</sup>  
Environmental Detection Systems  
Easy Answers.

## Sky King.



Frank McCowan, a Mohave, keeps an eye on the sky, as well as on operations at Westates Carbon reactivation facility built on Colorado River Indian Tribes land, Parker, Arizona.

*"Trust the sky to tell you when something is wrong. The sky is beautiful and very clear here. Except when the smoke blows in from the fires at Santa Ana, some 400 miles away." Frank McCowan, a full Mohave Indian, lives once again in his ancestral home, the Colorado River Indian Tribes reservation. "I came back here from a big city because the sky was polluted." It is only natural that Frank feels as much at home in the sky as he does on the ground. An ardent basketball player and kite flier, he is always striving to get airborne, to reach a little higher. Frank is also the head operator for our Westates Carbon reactivation facility, located entirely on the reservation. "The plant recycles used carbon, making sure that impurities are safely removed. Getting approval for this plant was not easy. We are very protective of the land here and 'Avil Asquil', our sacred mountain, stands only a few miles from this spot. So the plant had to meet our strict tribal guidelines as well as pass all federal and state restrictions. I know everything is right with this plant because I also helped to build it. As a Mohave, I have a sense of being part of a great scheme. It is in my blood memory. The sky, the water, the land belong to us only as long as we belong to them. Many things are different today, but these universal truths remain the same."*

To find out how the committed people of Wheelabrator can help bring a balanced approach to your trash, air and water pollution problems, call us at 1-800-682-0026.



*Wheelabrator Technologies Inc.*  
Where environmental quality comes first.

A WMX Technologies Company

Circle 23 on card.

# Air Compliance Goals To Crystallize In 1995

By Kenneth A. Reich

In 1990, Congress enacted a sweeping overhaul to the Clean Air Act known as the Clean Air Act Amendments (CAAA). One of the most complicated and comprehensive pieces of environmental legislation ever passed, the amendments have resulted in substantial regulatory changes at the federal and state levels.

The year 1995 promises more of the same as regulations previously proposed are finalized and EPA proposes new regulations.

While the mid-term elections certainly will have a profound impact on the next Congress and the type of legislative programs the Clinton administration will be able to pass over the next several years, they are not likely to have a significant overall effect on the key regulatory programs required under the CAAA. The reason is that the amendments contain a myriad of specific mandates and deadlines that EPA must meet, and the composition of the new Congress will not affect that reality. Indeed, if the new Republican majority attempted to prevent the Clinton EPA from following the strict requirements of the CAAA, the outcry from environmentalists and others would surely match that which greeted the early Reagan administration's attempts to reverse 10 years of environmental progress. Nonetheless, it will be interesting to observe whether the administration's stance on various hot issues, such as ozone transport and the low emission vehicle program, will change in light of the elections.

Among the key regulatory programs that can be expected to see significant action in 1995 are the Title V operating permit program, the enhanced monitoring rule under Title V, the low emission vehicle program and the hazardous air pollutants maximum achievable control technology (MACT) rules under Title III. In addition, EPA will face hard decisions regarding the treatment of ozone transport's impact on attainment, especially in the Northeast, and whether to sanction states for failure to enact effective automotive emissions testing programs as well as failure to meet other deadlines and requirements.

## Title V Operating Permits

On July 21, 1992, EPA issued final regulations for the federal operating permit program under the CAAA. These regulations are contained in 40 CFR Part 70. This program provides for a nationwide system of operating permits for major sources, sources of hazardous air pollutants subject to the technology standards under Section 112, sources subject to Section 111 New Source Performance Standards, any affected source under the Title IV acid rain provisions and other EPA designated sources.

The Title V permits, which are subject to EPA approval, must contain monitoring, recordkeeping and reporting requirements, provide for initial and annual compliance certifications and contain all of the principal requirements applicable to the source in one permit.

The operating permit regulations were immediately challenged in court by industry and environmental groups. After several years of unsuccessful negotiation, EPA proposed a set of revisions in an attempt to come up with a program acceptable to all sides. The revisions address many of the concerns expressed, particularly those relating to modifications (59 *Federal Register* 44469 August 29, 1994). The proposal contains expedited permit revision procedures for both minor modifications and *de minimis* revisions.

Under the proposed rule, sources could implement a *de minimis* change seven days after submitting an application for a permit revision to the state. Public notice of all *de minimis* changes received by the state for the previous month would be listed together in a monthly public notice. The proposed rule contains several numerical suggestions for *de minimis* thresholds, for which EPA is soliciting comment.

Minor modifications can be implemented under the proposed rule after public notice and a 21-day comment period if no objections are received. If objections to the minor modification are received but deemed frivolous or not relevant by the state, the source can implement the change on the 29th day after publication of notice. The minor permit revision automatically becomes effective if not disapproved by the state within 60 days after receiving the application for the revision.



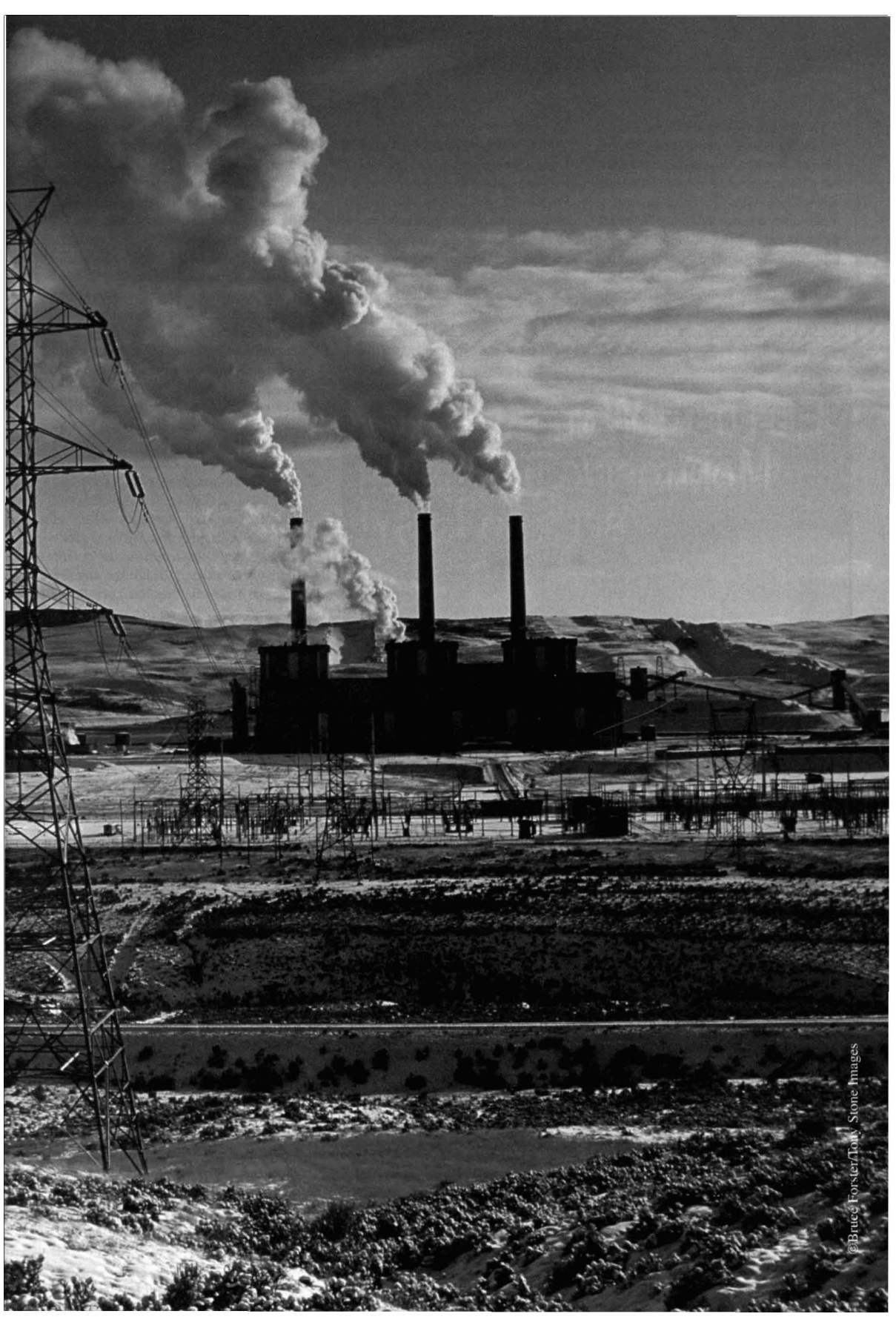

The proposal has stirred plenty of debate, particularly among state regulators who are unhappy with the automatic effectiveness feature of the minor permit revisions. EPA probably will issue a final set of revisions to these regulations this year. If the agency fails to act, the states may fall behind in promulgating their own operating permit regulations (which must be approved by EPA) and sources could have no operating permit programs to rely on.

### Enhanced Monitoring Rules

In 1993, EPA proposed an enhanced monitoring rule to go hand in hand with the operating permit rule (50 *Federal Register* 54648 October 22, 1993). The rule details the enhanced monitoring requirements for Title V sources. Such sources are required to monitor air pollutant emissions and certify whether continuous compliance with emissions limits has been achieved. As drafted, the proposal would sweep many minor emission units at

major sources and some minor sources of hazardous air pollutants into its grasp and would mandate continuous emission monitoring (an expensive process) of many emission units. The rule has met with fierce opposition from the regulated community, which saw it as overreaching and unnecessary. Industry pushed for a proposal in which only major emission units at major sources would be subject to the rule.

EPA has wrestled with the many critiques of its enhanced monitoring rule and announced that its final rule will focus on the most environmentally significant emission units only. The revision is expected to allow sources to choose from a series of monitoring equipment options based on type of pollutant and industrial process, size of emission unit and available technology.

The final rule is expected to be promulgated by the time this article appears.

### Hazardous Air Pollutants

Under the amendments to Section 112 of the Clean Air Act, EPA is required to develop technology-based standards (rather than numerical emission limits) for specified categories of industrial sources that emit one or more of the 189 hazardous air pollutants (HAPs) listed. Within the specified source category, all major sources of HAPs and selected non-major sources (called "area sources") are subject to these standards for maximum achievable control technology. A source is a major source of HAPs if it has the potential to emit 10 tons per year or more of any one HAP or 25 tons per year of any combination of HAPs.

As of November 1994, EPA had issued three rules in final form establishing MACT standards for categories of sources. The most comprehensive rule is the hazardous organic NESHAP (HON) for the synthetic organic chemical manufacturing industry (59 FR 19402, April 22, 1994, and 50 FR 29196, June 6, 1994). NESHAP refers to National Emissions Standards for Hazardous Air Pollutants.

The HON is a very lengthy and complex rule. It regulates emissions of listed organic chemicals from both new and existing chemical manufacturing sources and from equipment leaks at certain sources with polymer and resin production processes. EPA also issued MACT standards for perchloroethylene dry cleaners (58 FR 49354, Sept. 22, 1993), and coke ovens (58 FR 57898, Oct. 27, 1993).

The deadline for promulgating MACT standards for the next group of source categories was Nov. 15, 1994. Thirty-eight MACT standards were required to be published by that date including those for the petroleum refining industry, halogenated solvent cleaners

# EFFLUENT WATER QUALITY MONITORING HAS NEVER BEEN SO EASY!

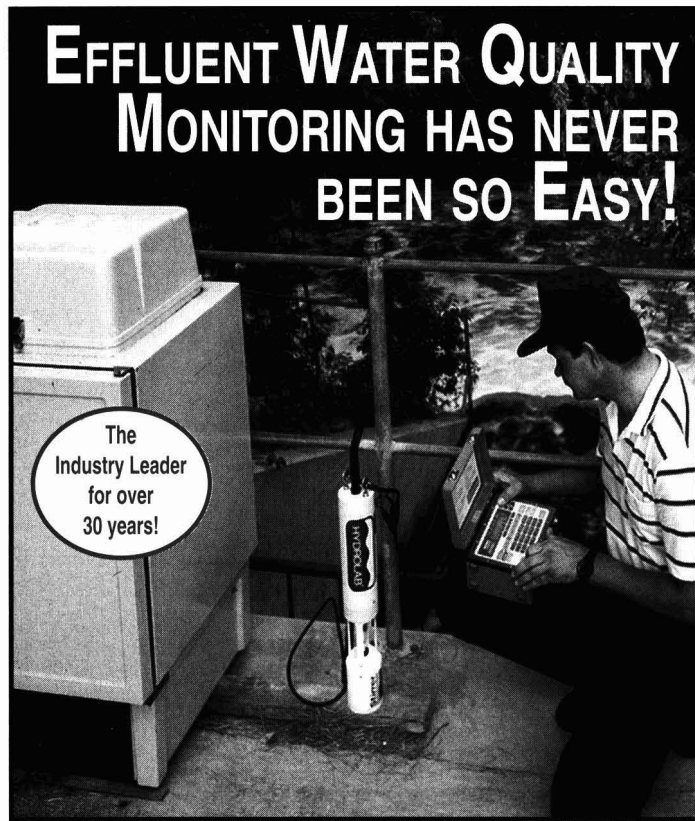

The Industry Leader for over 30 years!

Accurately measure, *in situ*, **DISSOLVED OXYGEN, TEMPERATURE, pH, SPECIFIC CONDUCTANCE, TURBIDITY,** and others – *simultaneously* – with just one multiprobe. Record and/or transmit water quality data from surveys, spot checks, unattended monitoring or multisite telemetry. Use these rugged, reliable multiprobes in fresh, salt, waste waters, and for in situ or purge sampling of ground water. All Hydrolab products carry a 2-year warranty. Call today for a brochure or assistance with your application!

**HYDROLAB CORPORATION**  
P.O. Box 50116 • Austin, TX 78763 • USA  
Telephone 800-949-3766 or 512-255-8841  
FAX 512-255-3106



*Helping preserve our world's water resources*

(degreasers) for major and area sources, gasoline distribution facilities (bulk terminals and marine terminals), aerospace industry, chromium electroplating, magnetic tapes (surface coating) and secondary smelters. Thus, there will be major regulatory activity under Title III in 1995.

### Low Emission Vehicle Program

The eastern states that make up the Ozone Transport Commission (essentially all states from Virginia north to Maine) under the CAAA have petitioned EPA to issue a final rule mandating the adoption of the California low emission vehicle (LEV) program in their corridor. Thus, auto manufacturers would be required to make and sell low emission and zero emission vehicles in the Northeast corridor as a means of enabling these states to attain the ozone standard. Several of the eastern states, notably New York and Massachusetts, have amended their laws and regulations to require the sale of such vehicles.

The auto industry has unsuccessfully mounted judicial challenges to such laws and regulations. Concerned about the prospect of producing a multitude of different low emission cars (the California car and zero emission vehicles), automakers offered EPA a compromise plan. The automakers proposed that EPA adopt a 49 state LEV. Under this plan, the automakers would manufacture a single LEV for the 49 states other than California. The 49-state LEV would be cleaner than current cars. On Dec. 19, 1994, EPA granted the petition of the Ozone Transport Commission to adopt the California LEV program. The decision came just after state Clean Air Act attainment demonstration plans were due on Nov. 14. Adjustments to the program are expected this year.

### Ozone Transport

One of the principal impediments to attainment of the ozone standard in the Northeast is the phenomenon of ozone transport — the migration of ozone produced by volatile organic compounds and nitrous oxide emissions in a upwind state to the downwind state. The problem is particularly acute for a downwind state, such as Massachusetts, where the upwind state, New York, is classified more stringently under the CAAA and thus has a longer period in which to comply.

On Sept. 1, 1994, EPA announced that it would allow non-attainment areas that demonstrated an inability to meet the statutory deadlines because of ozone transport to delay compliance until the deadline specified for the upwind area. The principal locations affected by this policy are the eastern states,

areas in the Midwest and near Los Angeles. That policy has been challenged by environmental groups in court.

It is unclear how this issue will be addressed in 1995, but it must be resolved since many states must meet interim and final deadlines by as early as 1996 and 1999. Unless downwind states can discount the effects of ozone transport, many of them may not be able to demonstrate attainment.

According to knowledgeable sources at EPA, other rules for which there is likely to be some action in 1995 include the New Source Review (NSR) regulations and the

Title IV acid rain rules. The NSR regulations, including sections on prevention of significant deterioration, will be amended to reduce program complexity, improve clarity and conform them to the operating permit requirements. Title IV regulations will be promulgated to provide the necessary procedures for allowing SO<sub>2</sub> sources to opt-in to the Title IV Acid Rain SO<sub>2</sub> Allowance Trading Program.

Naturally, the states will be very busy enacting their own rules, such as the operating permit rule, required under the CAAA, and generally conforming the state implementation plans

# How to measure light and heavy hydrocarbons in a single pass.

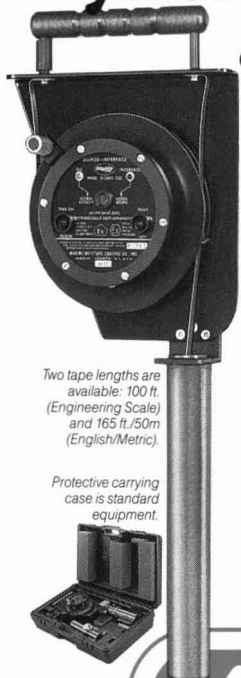

Two tape lengths are available: 100 ft. (Engineering Scale) and 165 ft./50m (English/Metric).

Protective carrying case is standard equipment.

This is the Environmental Engineering U/1 gauging tape from MMC International and it's made to order for gauging a groundwater monitoring column.

Just drop the weighted probe into the well. When it contacts floating hydrocarbons, a steady tone will be emitted. As it descends further, passing through this layer into water, the sound turns to an intermittent beep. Should it hit heavy hydrocarbons beneath the water, the tone will turn steady again.

What makes this possible is the piezo electric crystal in the probe and the different conductivities of the liquids. What it means to you is you get the measurements you need in the fastest possible time.

And here's more good news: We've simplified the design of this unit to bring its price below \$1,800.

Call or write for full information. Over 50 years of experience goes into every MMC product.

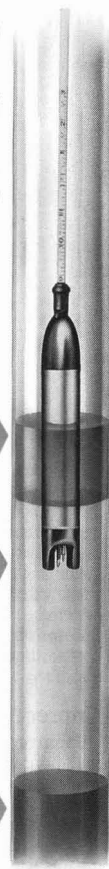

Floating hydrocarbon STEADY SOUND

Water: INTERMITTENT SOUND

Heavy hydrocarbon STEADY SOUND



Keeping You in Control

#### MMC International Corp.

60 Inip Drive  
Inwood, NY 11096-0664 U.S.A.  
Phone: 1-800-645-7339  
1-718-327-3430 • 1-516-239-7339  
Telex: 96-0140 MAMCAF INND  
Fax: 1-516-371-3134

#### MMC (Europe) Ltd.

South Nelson Road  
South Nelson Industrial Estate  
Cramlington  
Northumberland NE23 9HL UK  
Phone: (01670) 738111  
Telex: 537005 MARINE G  
Fax: (01670) 738789

#### MMC (Asia) Ltd.

7-7, 2-Chome, Kitonoo-Cho  
Chuo-ku, Kobe 651  
Japan  
Phone: (078) 251-1033  
Telex: 5624163 OPECK J  
Fax: (078) 252-0265

to all of the requirements imposed under the amendments. Further, attainment demonstration plans for serious, severe, and extreme nonattainment areas were due Nov. 15, 1994. Many states did not meet these deadlines for revisions and demonstration plans. Thus, there will be plenty of activity as states struggle to produce SIP revisions for EPA review.

It is unlikely that a Republican controlled Congress with a Democratic administration will enact any amendments to the Clean Air Act in 1995 or 1996, especially given the length of time and effort necessary to pass the CAAA in 1990. Indeed, it is doubtful that any significant environmental legislation will pass in the next two years, with the possible exception of some version of Superfund reauthorization.

Notwithstanding this probable lack of new legislation, EPA and the states will have more than their hands full in attempting to meet all of the deadlines for promulgating regulations under the amendments. **EP**

*Kenneth Reich is counsel to the firm Day, Berry & Howard in its Boston office and works in the Environmental and Land Use Department. He acknowledges the assistance of his associate Kathleen McFadden, who works with the firm in Hartford, Conn.*

## A Look Back And Forward

The 103rd Congress may be remembered as the session that introduced a lot of environmental inaction. The following is a status update of major legislation.

**Comprehensive Response, Compensation and Liability Act** – Although EPA's authority to administer the Superfund program expired at the end of 1994 and funding authority was extended only to the end of 1995, the 103rd Congress failed to reauthorize the program. Two bills were introduced and hearings held, but there was not enough time to resolve the issues. Superfund may be revisited again in the 104th Congress.

**Resource Conservation and Recovery Act** – Numerous bills were introduced, but not passed, leaving many serious issues for the next session. Issues that are expected to be reviewed are disposal of out-of-state municipal solid waste and the validity of "flow control" requirements.

**Safe Drinking Water Act** – Reauthorization bills passed by the House and the Senate would have established a state revolving fund to pay for drinking water programs. However, no agreement was reached, and reauthorization will have to take place in the 104th Congress.

**Clean Water Act** – Two reauthorization bills were introduced and died in the 103rd Congress. At this time, it is not known whether action will be taken for reauthorization in the next session.

**Pesticide and Food Safety Reform** – Bills offered in the last session would have created greater regulation of pesticides to better protect children, public health and consumers from pesticide residues in food. It is uncertain if these matters will be pursued in the 104th Congress.

**Risk Assessment and Cost-Benefit Analysis** – The Republican "Contract" called for legislation to require greater use of studies matching remedial programs to the actual level of risk presented and to set priorities for dealing with the greatest risks first. If the cost is excessive and the risk minimal, the money could be better spent elsewhere. These matters probably will continue to be pursued in the 104th Congress.

*By Marsha Anastasia, an associate in the Environmental and Land Use Department at Day, Berry & Howard, Hartford, Conn.*

# Revolutionizing Odor Control

Epoleon Corporation introduces an all new concept for odor control that works through specific methods of chemical neutralization to actually eliminate odor-causing gases. Epoleon's water-based formulas can be dripped or fed into wastewater, added into scrubber systems, or sprayed topically. Best of all, Epoleon's biodegradable, all-natural composition makes it equally safe and effective.

## Unprecedented Achievement

Upon contact, Epoleon's unique formulations will chemically attack and neutralize both acidic and alkali gases **simultaneously**. This makes for a thorough reduction in odor.

Epoleon chemically converts odorful organic acids into stable, organic salt compounds which are odorless, non-toxic and biodegradable. Because of its advanced organic composition, Epoleon agents are compatible with many types of bacteria and inorganic chemicals.

Here's how Epoleon works:

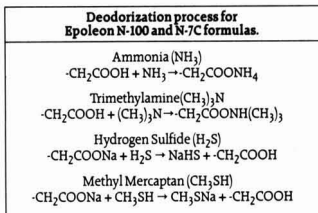

## Effectiveness Proclaimed Worldwide

Since its introduction, Epoleon has achieved international acclaim. Reports documenting Epoleon's effectiveness continue to pour in from around the

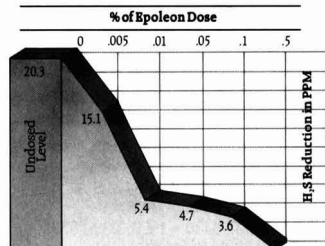

world. To quote Dr. Lawrence C. Koe from the University of Singapore, "Epoleon N-7C has been tested under laboratory conditions for reactions with municipal sewage samples. The chemical was found to be capable of reducing the potential of sewage to emit H<sub>2</sub>S volatiles. A dose of 0.5% Epoleon N-7C on sewage resulted in complete elimination of H<sub>2</sub>S emission."<sup>1</sup>

<sup>1</sup> Dr. Lawrence C. Koe, Laboratory Study on the Effectiveness of Epoleon N-7C for Hydrogen Sulphide Reduction (National University of Singapore), 1991.

## A Product for the Times

Epoleon's progressive invention offers an approach to odor control that meets, even surpasses, today's environmental standards. Trust Epoleon to revolutionize your odor control program.

For more information on Epoleon products, call 1-800-HIT-ODOR.

## EPOLEON® Corporation

19160 S. Van Ness Ave.  
Torrance, California 90501-1101  
(310) 782-0190, 1-800-448-6367  
Fax: (310) 782-0191

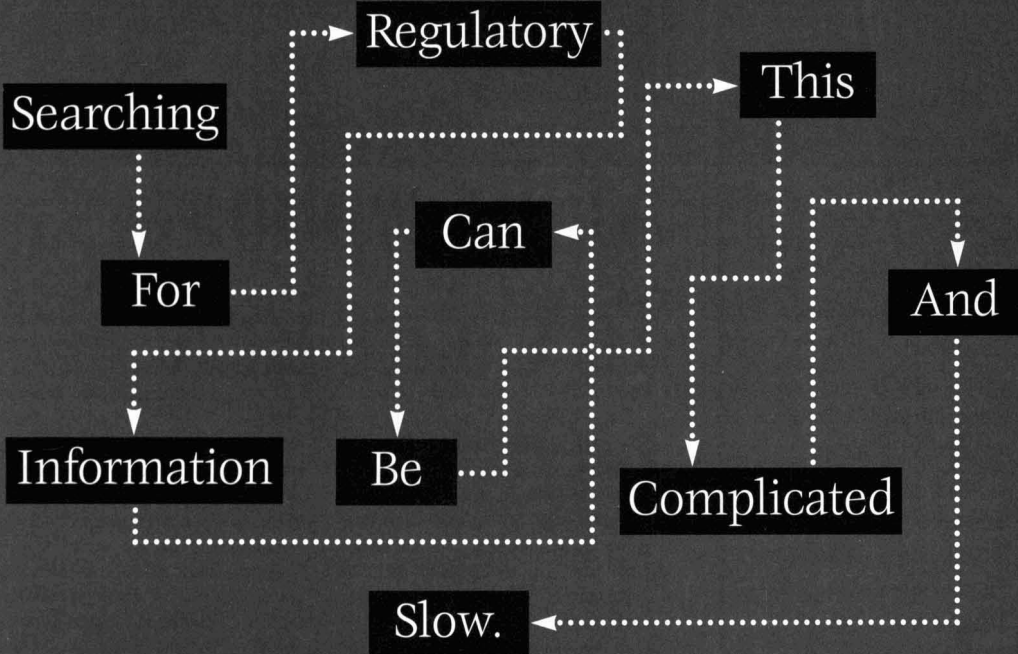

*Until You Use EarthLaw.*

Managing regulatory information has always been a complicated, time-consuming task. But now there's EarthLaw. You can find the most current information, in seconds, on your own PC.

**It's Complete.** The most comprehensive collection of information available:

- Environmental regulations from 50 states and D.C.
- Occupational safety regulations from 46 states and D.C.
- Complete Federal EPA and OSHA regulations and laws.
- State and Federal DOT regulations on packaging and transporting hazardous materials.
- State regulations on handling flammable materials and means of egress.
- Guidance publications and manuals from NIOSH and OSHA
- Air Force, Navy, DOD, and COE occupational safety publications.
- ANSI, ASTM, ASME, AWS, SAE and UL standards cited in the CFR.
- The Federal Register - all 50 titles online.

**It's Current.** Available on CD-ROM (updated monthly) and online (updated daily).

**It's Smart.** Logical, easy searching so you can get accurate results right away.

**Try It.** For a free trial of EarthLaw, call us today at **1-800-320-4555**.



**EarthLaw**  
Environmental & Safety Libraries

➤ IHS Regulatory Products • 15 Inverness Way East • P.O. Box 1154 • Englewood, Colorado 80150-1154

Circle 27 on card.

## Meteorological Instruments

- Wind Speed
- Wind Direction
- Air Temperature
- Relative Humidity
- Precipitation
- Barometric Pressure
- Solar Radiation
- Data Loggers
- Recorders
- Towers & Elevators
- Lightning Protection
- Software
- Installation & Calibration
- Field Service
- Technical Assistance
- Service & Repair
- Instrument Shelters

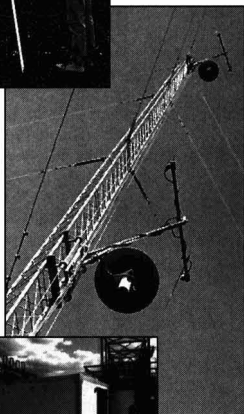

**Met One  
Instruments**

1600 Washington Blvd., Grants Pass, OR 97526  
Phone (503) 471-7111, Fax (503) 471-7116

## Legal Watch

By Bert Black  
and Lynn Strott

# An Exception To Court Rule

In August, 1994, the U.S. Court of Appeals for the 3rd Circuit handed down a decision that could make it much easier to challenge Superfund remedies in court. The Superfund law explicitly limits judicial review of removal or remedial actions.

But there are five exceptions:

- If a suit has been initiated to recover for costs already expended or damages suffered;
- If an action has been brought to enforce a clean-up order;
- If a party that has complied with an order goes to court seeking reimbursement;
- If a citizens' suit is brought; or
- If the government seeks to compel a cleanup.

Until the 3rd Circuit's decision in *U.S. vs. Princeton Gamma-Tech Inc (31F.3d 138)*, it was generally thought that even under these exceptions, a party challenging a remedy selected by the government would have to wait until the remedy had been fully implemented before seeking judicial review.

This requirement created cruel dilemmas for parties who believed remedies were inappropriate, too costly or even harmful. Waiting for the government to complete work often makes legal action meaningless, and in some cases may lead to the imposition of treble damages if a challenging party refuses to follow an order and then loses on appeal after the government has sued. The government, of course, has always argued for the "no suit until the work is done" rule because it accelerates cleanups and provides a good way to bludgeon parties into settlement.

This court decision may significantly change this biased equation. The case involved property in New Jersey where the groundwater had become contaminated with trichlorethylene. EPA initially required installation of an alternative water supply, and later adopted a remedial plan calling for the extraction of contaminated water and for

monitoring wells to be sunk into a deeper aquifer to allow for sampling and testing. In 1991, EPA sued to recover what it had spent. The agency also sought a declaratory judgment for future costs.

The defendant company responded to the government's suit by challenging the remedy selected by EPA, and by seeking to enjoin further work. The company argued that EPA's plan would make environmental conditions at the site worse, and would, in fact, cause irreparable harm. The trial court, in keeping with prior cases, ruled that it had no authority to issue an injunction, and the company appealed.

Of the five exceptions to the no-prior review rule, the Princeton Gamma-Tech case relied solely on the exception allowing challenges when an action has been brought to recover response costs. Indeed, there is nothing in this statutory language indicating that a remedy must be complete, only that a cost recovery action has been brought, and in this case the 3rd Circuit held that the company could challenge the remedy prospectively. The court was swayed by the fact that the remedy allegedly would cause permanent harm.

This ruling on the first exception still requires that legal action be initiated against a party before that party can challenge a remedy, so it would do little for a company in Princeton Gamma-Tech's situation if the government decided to delay suit until all work was finished. The court, however, went on to hold that the citizen's suit exception to the no-review rule also might apply. The language of this section is somewhat more problematic than the cost recovery exception, because it refers to allegations that an action taken or secured "was in violation" of the law. The past tense used in this provision arguable means that citizens' suits cannot be brought until challenged action has been completed, and most courts before this case had interpreted the law in this way.

Not so, held the 3rd Circuit. Again relying on the fact that Princeton Gamma-Tech had alleged that permanent harm would result if the government's actions were not enjoined, the court held that "in circumstances where irreparable environmental damage will result from a planned response action, forcing parties to wait until the project has been fully completed before hearing objections to the action would violate the purposes" of the Superfund law. Recognizing that the language of the citizens' suit exception was at least ambiguous, the court turned to a review of the statute's legislative history.

Sen. Strom Thurmond, R-S.C., stated that the law was "designed to preclude lawsuits by any person concerning particular segments of the response action...until those segments of the response had been constructed and given the chance to operate and demonstrate their effectiveness." Sen. Robert T. Stafford, R-Vt., stated otherwise. According to him, it is "crucial, if it is at all possible, to maintain citizens' rights to challenge response actions, or final clean-up plans, before such plans are implemented even in part, because otherwise the response

---

*"The government should not be able to force useless or harmful actions on citizens without right of appeal."*

---

could proceed in violation of the law and waste millions of dollars." The 3rd Circuit acknowledged that taken together, these statements hardly provide crystal-clear guidance. For the court, however, it was important to distinguish between suits seeking monetary damages and those alleging irreparable harm.

The government sought a re-hearing of the Princeton Gamma-Tech case, but on Nov. 10, 1994, it was denied. For Superfund responsible parties, and for neighbors of Superfund sites who fear that remedial actions might be ineffective or even harmful, this case offers

new hope. Where before they had to bide their time and wait until unacceptable measures had been completed, now they may be able to challenge them up front. As a matter of policy, the case makes good sense. The government should not be able to force useless or even harmful actions on citizens without giving them some real right of appeal. The counterargument, that appeals may slow down the Superfund process, has some validity, but courts following the *Princeton Gamma-Tech* lead can be selective about which cases they allow to go forward, limiting review only to those where there are genuine allegations that harm will result. If this is the ultimate result of the case, it will indeed prove a very beneficial precedent.

Readers should note that a parallel case, also decided by the 3rd Circuit, indicates a similar result. The name of this case is the *United States vs. American Color & Chemical Corp.* (37F.3d 1489). **EP**

*Bert Black is the partner in charge of the environmental law practice group at Weinberg & Green, Baltimore, Md. Lynn Strott is an associate with the firm.*

# ENVIROSHELTER

Designed to all recognized building and fire codes

Anchor systems requiring no footings or foundations

Modular accessory packages

Installed quickly, safely, with minimal material handling equipment

Serving Your Clean Up Needs....

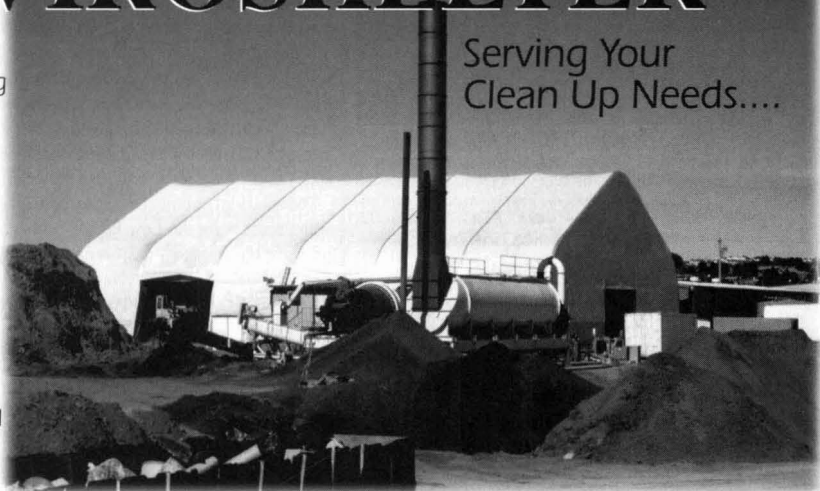

**Quality ■ Performance ■ Value**

Call or Write for FREE Catalog

**CLAMSHELL BUILDINGS, INC.**

1990 Knoll Drive ■ Ventura, California 93003 ■ (805) 650-1700 ■ Fax (805) 650-1733



# TSDF Site Selection: A Three-model Approach

*Finding the right location for a treatment, storage or disposal facility often is bogged down by political dynamics, regulatory and economic concerns. The right model for the job can make a difference.*

By Mark A. Finkelstein



*Congressional delegations chose this site (below) at Yucca Mountain, Nev., for the Department of Energy's High Level Radioactive Waste Disposal facility. Above, a worker at a small drill rig uses the machine to collect data and core samples for further study. Photos courtesy U.S. Department of Energy.*

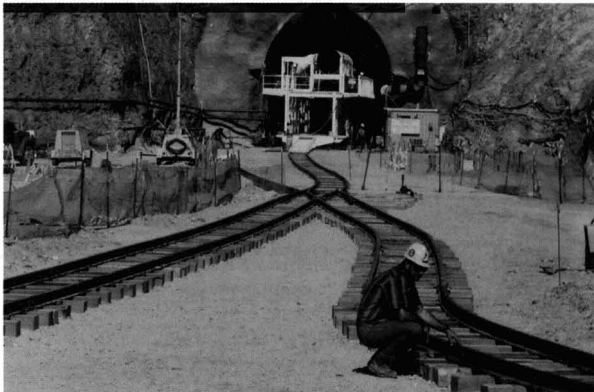

**S**iting waste treatment storage and disposal facilities has become a billion-dollar industry. Experts on projects from the Department of Energy's (DOE) proposed Yucca Mountain High Level Radioactive Waste Disposal facility to the Orange County Landfill wage war over the necessity, location and design of waste management facilities.

The ultimate success of waste management policy depends in large part on the quality of design and siting processes.

## Siting Process Models

Generally, three basic models – governmental, quasi-governmental and private party – are used to site waste treatment, storage and disposal facilities.

Under the governmental system, one of the political branches of government makes a siting decision. A classic example of this system was the *de facto* selection of Yucca Mountain, Nev., as the DOE's High Level Radioactive Waste Disposal facility under the Nuclear Waste Policy Amendments Act of 1987. The high level radioactive waste site was chosen by the congressional delegations of 49 states that "selected" the state of Nevada.

The quasi-governmental approach is exemplified by the siting process for the Low Level Radioactive Waste repository for the Southeastern Compact. At the request of the

National Governors' Association, Congress enacted the Low Level Radioactive Waste Policy Amendments Act of 1985. The act made each state responsible for its own low-level radioactive waste, encouraged states to form multi-state compacts for its management and imposed sanctions against states that failed to provide waste disposal options.

North Carolina and seven other southeastern states formed the Southeastern Compact, with their repository located in



## Silicate Treatment For Hazardous Wastes

Soil solidification and stabilization with sodium silicates in combination with concrete is a proven, reliable technology for treating liquid and semi-liquid wastes.

In fact, EPA has named solidification and stabilization as one of the best demonstrated available technologies for converting liquid or semi-liquid wastes into chemically stable forms.

Despite its proven effectiveness, using silicates and cement to solidify and stabilize soil has not achieved widespread use. One cause of underutilization is the reputation the process has for being difficult to use. Most users do not apply the level of science needed for successful treatment and often opt for more expensive but less effective means of treating problems suited to silicate and concrete remediation. For remediation engineers willing to apply scientific principles, solidification and stabilization with sodium silicates and concrete can outperform more expensive technologies.

Silicates are produced by fusing soda ash or potassium carbonate and specially selected silica sand at high temperatures. The result is an amorphous glass, which can be dissolved in water to produce the liquid "waterglass."

Soluble silicates in solution with concrete react with hazardous wastes to produce less hazardous substances by converting soluble metals into insoluble metal silicates and encapsulating hazardous organic and inorganic components within an acid-resistant matrix with reduced permeability. Silicates accelerate the solidification of concrete while making an impermeable outer layer — enhancing the "trapping" of waste materials within the resulting concrete formation.

A user should first select a binder level. Each waste site is different. One should test the mix design to ensure required treatment levels are reached. Typical experience shows a waste or soil ratio of 0.2 or higher is appropriate for a monolith while a ratio of 0.08 to 0.2 is appropriate for a loose, soil-like binder.

Using the right amount is critical because too much water will increase porosity and reduce the stabilized solid's strength while too little makes mixing difficult and reduces treatment effectiveness. Originally, water content was based on binder content, particularly when dealing with low-solids liquid wastes. The hydration process alone requires 23.5 percent water by weight of binder.

The optimum water:binder ratio for monoliths with minimum permeability but maximum strength ranges from 0.32 to 0.60. In forming monoliths from high-solids wastes, such as soils and sludges, water content should be related to the total solids of the waste plus binder, not just to the binder used in the mix, because the water is absorbed by the solids. For high solids wastes, the water total solids ratio should be between 0.4 to 0.5.

The user should mix the material by hand or use a mechanical, low-shear mixer. Water usually is added to the soil first, followed by the binder. Within three to five minutes, the hydration reaction should occur and this amount of time should be used for each test. Finally, the user should add the silicate and completely disperse it through the mixture. The silicate should not be added until the mix is ready to be discharged from the equipment; otherwise, the mix could set up in the equipment. Mixing in the proper sequence and to the appropriate degree will guarantee the right results. Insufficient mixing results in localization of untreated hazardous constituents, while excessive mixing inhibits gel formation and ion absorption on cement or pozzolan surfaces. This is the critical point in the treatment process.

To determine which combination of setting agent and silicate produces the best results, the user should run performance tests. The performance of the mixture will be enhanced by running three experiments with optimum water/binder levels by adding 8 percent, 6 percent and 4 percent soluble silicate by weight of binder. The user should calculate the silicate on an as-is basis, and subtract from the process the incoming water from the silicate for each experiment. It is important never to add more than 8 percent silicate by weight of binder. To minimize costs, choose a lower binder level and run the experiment again.

If the mixture needs improvement, a different silicate may be appropriate. If the waste is particularly acidic, a lower ratio silicate should be used. If the set time is too short, perhaps a powdered soluble silicate will be effective.

By using a scientific approach to treatment development, practitioners can use silicates with increasing success to improve performance and reduce cost. Used properly, silicates will result in a strong, low permeability, chemically stabilized solid that is easy to handle, transport and place in a landfill.

*By Michael K. Kovacs, is a product manager for PQ Corp., a manufacturer of sodium silicates. A member of the Air and Waste Management Association and the American Chemical Society, Kovacs has led the company's soil remediation marketing efforts since 1989.*

## Legendary quality, high performance and innovation ...

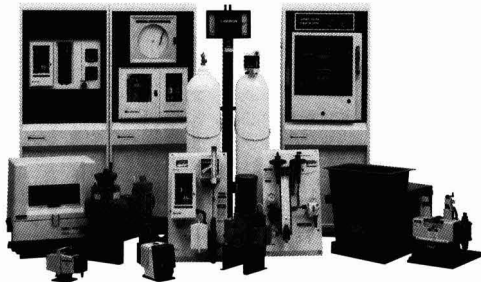

Wallace & Tiernan is a worldwide organization, dedicated to continuing the kind of quality products and service that customers have come to expect from Wallace & Tiernan.

We offer the world's most comprehensive line of chemical feed equipment for water and wastewater treatment.

Whatever your needs, Wallace & Tiernan products are top performers and a cost-effective investment: in chlorination/dechlorination, disinfection analysis and control — or liquid and dry chemical dosing and metering systems such as fluoridation, lime slaking and polyelectrolyte preparation systems.

As always, Wallace & Tiernan products are available locally through a highly experienced sales organization and through a nationwide network of authorized distributors. W&T also has manufacturing facilities and sales offices in Australia, Brazil, Canada, Mexico, the United Kingdom and Germany.

For information concerning any of our products, contact us at:

Wallace & Tiernan, Inc.  
25 Main Street  
Dept. MP005  
Belleville, NJ 07109.

Or call us at (201) 759-8000.



Circle 30 on card.

# DIVERSIFIED WELL PRODUCTS, INC.

**Monitoring Features Include:**

- Control & display flow rate & gallons pumped
- Multiple or single well systems
- Alarms, lights or relays that close valves, turn off other systems, send warnings, etc.
- Control & display water level
- Auto restart



**STEP UP TO  
THE NEXT PLATEAU  
IN REMEDIATION SYSTEMS -  
CUSTOM DESIGNED TO YOUR  
COMPANY'S OWN SPECIFICATIONS!**

**REMEDICATION SYSTEMS:  
1-800-225-WELL**

Circle 31 on card.



**LEADING THE WAY  
TO A BETTER ENVIRONMENT**

- Fully permitted • 450 waste codes • Prompt approvals • Competitive pricing
- 24 hour transportation service • 24 hour plant operation • Analytical service
- Field service • Lab Pack • 20 years of experience and service

**313-571-7141**

6520 Georgia Detroit, Michigan 48211 313-571-7141 Fax 313-571-7190

Circle 32 on card.

Barnwell, S.C. In 1986, North Carolina was chosen by the Compact Commission to succeed South Carolina as the second host state for the repository. In response to the commission's selection, North Carolina General Assembly enacted legislation establishing broad site criteria and created a 15-member authority to oversee the selection, construction and operation of the waste repository. On Dec. 8, 1993, the authority members selected a site on the Wake County/ Chatham County line to house the next repository for the Southeastern Compact.

**Traditional Process**

The private selection model is the traditional American process whereby private industry selects a site in response to economic and organizational factors and seeks the necessary land use and environmental permits from regulatory officials. Under the proper circumstances, this process has proven to work more smoothly than any of the other processes.<sup>1</sup>

Governmental, quasi-governmental and private siting processes each offer unique advantages and disadvantages. Siting a large, controversial, monopolistic facility requiring governmental funding may be politically possible only if a governmental process is adopted. The disadvantage of such governmental selection processes is that they are by definition subjective and arbitrary.<sup>2</sup>

Assuming private organizations act rationally while accurately taking into account all external economies and diseconomies, such as the costs and benefits of recycling and pollution, the private siting process is optimal. These assumptions are never completely accurate, however, because it is in a sense irrational for a private organization to internalize public external economies and diseconomies. Moreover, sometimes near-optimal private siting decisions are prohibited or made prohibitively expensive by factors such as land use regulation and litigation.

The proper role of environmental regulation in the site selection process is to protect human health and the environment by forcing siting decision makers to internalize external costs and benefits. The success of the private system is exemplified by most of the private solid waste landfills in North Carolina. These facilities are providing relatively low-cost disposal with little environmental degradation of the human environment or special ecosystems.<sup>3</sup>

Given the theoretical efficiency of the private system, many commentators question the need for other systems of environmental decision making.<sup>4</sup> Significant value judgments are present in siting decisions. For instance, how much more are we willing to pay for land to minimize the transportation and air pollution risks associated with fewer and more remote waste facilities? No siting decision can be based solely upon pure economics and technical siting data.

The desirability of siting decisions based upon the classical economic private system model rests on a number of assumptions that experience shows is not always true.

The first questionable assumption of the private system model is that individuals and corporations are rational utility maximizers who consistently base decisions on economic well-being.<sup>5</sup>

Second, the model assumes the irrelevance of social and political processes by supposing that there is no meaningful way to compare individual and group preferences because they are inherently subjective.

Third, the model assumes that costs — negotiating compensation for those injured and litigating the legal rights of all parties affected by a siting decision — are inconsequential.

The set of events that led to the use of an old lightweight aggregate kiln to assure North Carolina's capacity to manage its hazardous waste demonstrates many effects of the failure of the private system model. As a result, a lightweight aggregate facility run by Carolina Solite rather than a new facility proposed by ThermalKem became North Carolina's principal hazardous waste incinerator.

Carolina Solite and its sister company, Oldover Corp., operate four aggregate kilns where shale is heat-expanded for use in cinder block. The Resource Conservation and Recovery Act (RCRA) created a need for hazardous waste disposal and a loophole for disposal through energy recovery facilities such as Solite's aggregate kilns.<sup>6</sup>

In the early 1980s, Solite switched from burning coal to burning millions of gallons of hazardous waste fuel without adding a single pollution control device. About the same time Solite became North Carolina's largest burner of hazardous waste, ThermalKem and the North Carolina Hazardous Waste Management Commission began a search to site a haz-

# UNIMAX

## LARGE WALK-IN FUME HOODS

- **Durable advanced composite chemical resistant construction (No Steel Framing)**

- **Exhaust, filtration systems meet OSHA & EPA clean air requirements**

- **Services, accessories to suit your specifications**

- **Special doors, floors can be custom engineered**

- **Custom built in sizes up to 16'Wx8'Dx12'H, complete with services to suit**

### ★ New HAZMAX Safe Work Enclosure

A large hazardous containment work area similar to the Unimax, except with recessed containment basin to control accidental spills. The answer to OSHA safe designated work areas!



**HEMCO** For prompt service, call (816) 796-2900

111 North Powell, Independence, MO. U.S.A. 64056

Circle 33 on card.

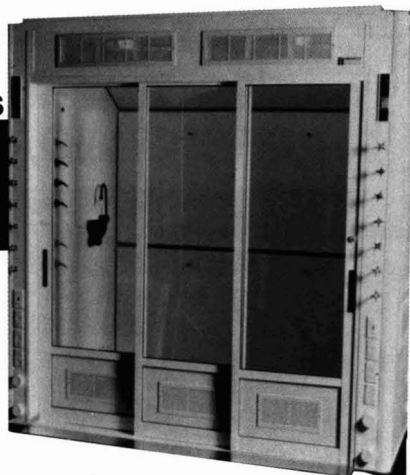

# OZONE

- **Disinfection**

- **Advanced Oxidation**

- **Organic Destruction**

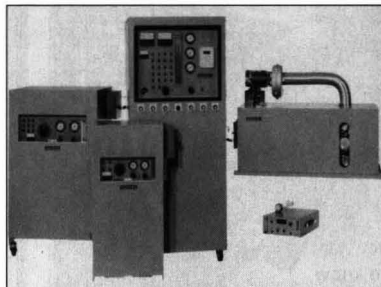

Ozone, the strongest commercially available oxidant is produced on site for your critical water and waste water treatment applications. OREC offers complete systems including ozone generators, monitors, contactors, catalytic ozone destructs and control options to meet the toughest applications. Low cost, dependable, easy to install systems, backed by corporate strength and national/international service. For information on pilot studies, rental equipment, financing programs or technical assistance from 35 years of experience, call OREC.

**Experience the Results! Call 800/321-8200**



**OZONE RESEARCH & EQUIPMENT CORPORATION**  
4953 West Missouri Avenue • Phoenix, AZ 85301-6100 USA  
Phone: 602/931-7332 • Fax: 602/931-7727

Circle 34 on card.

# FBS COVERS A LOT OF GROUND, QUICKLY.



## PORTABLE, LOW-COST STRUCTURES

- CLEAR SPANS 40'-200'-ANY LENGTH
- TRANSLUCENT FABRIC-REMOVABLE
- FABRIC LASTS UP TO 20 YEARS
- 70-120 mph WIND LOADS
- UP TO 4' SNOW LOAD
- HVAC SYSTEMS AVAILABLE



**813-351-6096**  
**FAX: 813-351-1020**

*Manufactured exclusively by CanSpec*  
4919 80th Avenue Circle East, Sarasota FL 34243

Circle 35 on card.

**Get the "hole" picture!**

...if you want to know what's up you've got to look at what's down; subsurface. We do just that - borehole geophysical services, rental equipment and interpretations for fracture characterization, in-situ flow and water quality.

17301 W. Colfax, Suite 255 • Golden, CO 80401  
(303) 279-0171 • FAX (303) 279-2730

32 Circle 36 on card.

## ENVIRONMENTAL LIABILITY INSURANCE

- Asbestos Abatement
- Lead Abatement
- UST Removal
- Hazwaste Remediation
- Consultants & Labs

## Workers' Compensation\* Contract Surety Bonds\*



*Insuring The Environment\**

**Rated A- (Excellent)**

by A.M. Best

**(800) 388-3647**

**1900 The Exchange, #450  
Atlanta, GA 30339**

\* Provided by independent carriers

Circle 37 on card.

## Site Selection

ardous waste incinerator that complied with all of the requirements of RCRA Subtitle C.

Because Carolina Solite had a pre-existing operation with longtime employees and an active community relations program, the community never fully mobilized in opposition. Although state officials found fugitive emissions with a potential increased cancer risk as high as 1 in 500, environmental organizations focused their attention on the proposed Subtitle C facility rather than the existing facility. The end result was the continued operation of a somewhat improved Solite, conciliation write-off of the ThermalKem project and the legislative death of the North Carolina Hazardous Waste Management Commission.

The public's misunderstanding of risk assessment - an external diseconomy - led to disproportional burdens being placed on the siting of a new facility incorporating more protective technology.

### Siting Decision Obstacles

Challenges to site selection processes generally take place in three forums: technical, political and judicial. Selecting a satisfactory site from a technical perspective is a step in the right direction. A good technical decision is neither necessary nor sufficient to survive legal and political challenges, however.

Avoiding legislative opposition to a siting decision is a classic public relations issue. The legislature is not conducive to dispassionate scientific review. Legitimate environmental concerns often cannot compete for legislative attention with other issues. Siting decisions affecting politically powerful areas have been reversed by legislative action after major public relations campaigns.<sup>7</sup>

On the other hand, some efforts to avoid legislative scrutiny have been successful by limiting the opposition to geographically and socioeconomically discrete groups and pitting regions and individuals against other regions and individuals.

Judicial derailment of a site selection process is overcome by careful compliance with the laws governing site selection and permitting for treatment, storage and disposal facilities.

### The Selection Process

Regardless of which siting process is used, a set of siting criteria must be adopted, along with data regarding that

ENVIRONMENTAL PROTECTION

criteria and a method for the decision makers to arrive at a siting decision.

Choosing factors to consider in the site selection process and obtaining data on those characteristics are relatively straightforward issues for a good team of environmental professionals. The North Carolina Low Level Radioactive Waste Management Authority, for example, reviewed the factors developed by its contractor, Chem Nuclear Systems Inc., in its site selection process (see Table 1, page 35).

Treatment, storage and disposal siting practices generally are simple processes of elimination. Starting from a particular political or geographic region (such as a state or county) distant from a critical center or geological feature, environmental professionals identify tracts of potentially suitable lands that are large enough for the proposed facility. Thereafter, the selection process screens out those sites that are prohibited by applicable law, regulation or economic and political realities.

This process generates a number of suitable candidate sites that have varying impacts on the environment, public health and surrounding social, political and economic systems. From this point on, professional judgment steers the siting process.<sup>8</sup>

The process of applying human judgment to siting data is extremely time-consuming and subject to attack as arbitrary and capricious. The development of fuzzy-set mathematics presents a tool for rationalizing professional judgment.

Fuzzy-set mathematics was developed by Professor Lotfi A. Zadeh during work on process control engineering during the mid-1960s. The professor currently works for the environmental engineering department of the University of California-Berkeley.

Fuzzy-set theory is described as a system to transform subjective and ambiguous information such as expert opinions and rules of thumb into numerical data in a systematic way so that such data may be directly incorporated into a solution.<sup>9</sup> In fact, it is perhaps more accurately described as a means of transforming numerical data into "expert conclusions."

The concept of using fuzzy-set mathematics to assist in site selection is readily described to the layman. Fuzzy-set mathematics itself is more difficult. Conceptually, one assigns a numerical weight or range of weights to each siting criterion expressing that criterion's significance

At GES, choosing the right techniques to resolve your remediation concerns is a critical part of the job.

Appropriate technology selection, well-planned execution and efficient project resolution ... now *that's* good thinking.

Rapid sampling equipment  
Remediation testing  
Remediation systems  
GeoProbe®  
Bio-feasibility studies  
Bioremediation  
VR systems  
Thermal oxidation units  
Catalytic oxidation  
Phased approach  
Dewatering and treatment trailers  
Remote telemetry

## Smarter remediation choices.



Call 800-220-3068 today to learn more.

**GES** Groundwater & Environmental Services, Inc.

1340 Campus Parkway, P.O. Box 1750, Wall, NJ 07719

Offices in Connecticut, Maryland, Massachusetts, New Jersey, New York, Pennsylvania, Rhode Island

1985-1995—Ten Years of Environmental Excellence  
**Circle 40 on card.**

### Complete manufacturer & supplier of . . .

- Thermal Oxidizers
- Ground Flares
- Inert Gas Generators

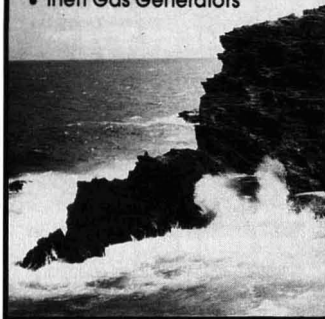

### Clean Air Solutions



**WHITE HORSE**  
TECHNOLOGIES, INC.  
3211 Shannon St. Santa Ana, CA 92704  
(714) 438-9270 • (612) 783-9980  
Fax (714) 438-9275

**Circle 38 on card.**

### The professional weather station for people curious about the weather.



Haven't you always wanted a weather station? The Weather Monitor II makes a state-of-the-art weather monitoring system affordable enough for home use!

#### FEATURES INCLUDE:

- Inside & Outside Temps
- Wind Speed & Direction
- Barometer
- Time & Date
- Inside Humidity
- Wind Chill
- Alarms
- Highs & Lows
- Rainfall Option
- Instant Metric Conversions
- Outside Hum. & Dew Point Option
- Optional PC Interface

Order today: EP649E

**1-800-678-3669**

M-F 7 a.m. to 5:30 p.m. Pacific Time •  
FAX 1-510-670-0589 • M/C and VISA  
One-year warranty • 30-day money-back guarantee

**DAVIS INSTRUMENTS**  
3465 Diablo Ave., Hayward, CA 94545

**Circle 39 on card.**

## Table 1. Site Selection Factors To Consider

### Hydrological and Geological

Surface Water – flood plains, coastal high-hazard areas, wetlands, climate and rainfall patterns, drainage in and around the site, stream density  
 Groundwater – depth to water table, groundwater travel time, discharge within the disposal site  
 Geology – ability to characterize, model, analyze and monitor disposal site, mines  
 Geologic stability – seismic activity, earthquake faults, folding and volcanism, surface geologic processes, topography and slope, cavernous bedrock  
 Soil characteristics – composition and permeability, pH and cation exchange capacity, potential for erosion

### Environmental, Public Health

Water Quality – Surface water and groundwater, proximity/detriment to public water supply watersheds, detriment to sole source aquifers and springs and to drinking water wells  
 Demography – Projected population growth, future developments  
 Air Quality

### Natural and Cultural Resources

Wildlife – wetlands, gamelands, wildlife refuges and fish hatcheries, endangered species habitats  
 Recreation – parks, forests and recreational facilities, wilderness areas, nature preserves, proximity to scenic areas, historic sites, water resources, mineral resources, other resources (geothermal energy sources, timber)

### Local Land Uses

Potentially Adverse Activities – pumping large amounts of water, quarry blasting, use of conflicting sources of radioactivity  
 Large Land Holdings – state or federally owned sites, land holdings by utilities or other industries

### Transportation

Proximity to waste generators and major highways, route safety, method of transportation

### Aesthetics

Visibility, appearance, noise levels

### Additional Criteria

Minimizing displacement of permanent residents and improvements to real property, land acquisition, construction and relocation costs

## PALLFLEX®

**THE  
SOURCE  
FOR  
EXCLUSIVE**



- Teflon\* coated Glass Fiber Filters
- Pure Quartz Fiber Filters
- Pure Teflon\* Disc Filters
- Pure Borosilicate Glass Fiber Filters

**FOR USE IN HI-VOL SAMPLERS**

- PM<sub>10</sub> Samplers
- Dichotomous Samplers
- Diesel Exhaust Analysis
- Custom Apparatus

**Available 8mm to 40 inches**

**PALLFLEX CO.**

125 KENNEDY DRIVE  
PUTNAM, CT 06260

(OF PALL CORPORATION)

PHONE (203) 928-7761

FAX (203) 928-3584

\* Trademark of E.I. duPont de Nemours & Co.  
(Fiberfilm & Tissuquartz are trademarks of Pallflex.)

## Instant Holding Tanks



Petro-Flex®

Chem-Flex™

- Ideal for waste holding and emergency spill clean-up
- 100 to 100,000 gallon capacities
- Fully collapsible & portable
- Used by U.S. Army, Navy, Marines etc.

THE ESSENTIAL HAZMAT TOOL  
IN STOCK FOR FAST EMERGENCY SERVICE

**AERO** 800-526-5330

**AERO TEC LABORATORIES, INC.**  
Spear Road Industrial Park  
Ramsey, NJ 07446-1251 USA  
Phone: 201-825-1400

**FREE**  
FULL COLOR CATALOG!



We Specialize in Hand-Operated  
Soil Sampling Equipment for the  
Pollution Control Industry!

- Backsaver Handles
- Sampling Tubes with Liners
- Bucket Augers
- Complete Kits

**Call or Write Today!**

Clements Associates Inc  
1992 Hunter Ave. Newton, IA 50208  
PH: 1-800-247-6630 or 515-792-8285

## Site Selection

and obtains a numerical value or range of values expressing the data obtained regarding a particular criterion at a particular site. The sum of the products of these calculations for each potential site are compared. The site with the best score or range of scores may be called the "best site."

Assume a siting decision is to be made on only two factors: low pH and a low number of years with more than 70 inches of rainfall. If a decision was made to weight each factor based upon a survey of 10 recognized experts, and the result of the survey was a determination that soil pH was 8 to 10 and the rainfall criteria was a 4 on a scale of 1-10 (with 1 indicating the greatest importance and 10 indicating the lowest importance), then a site with a soil pH of 5 and 4 years of rainfall in excess of 70 inches over the past 100 years would be preferable to a site with a soil pH of 8 and 2 years with rainfall of more than 70 inches.

The fuzzy logic process begins after the siting criteria are established and data on each subfactor for each criteria has been obtained. The first step is to obtain a

numerical score for each subfactor based upon data acquired regarding the attributes of a subfactor. For example, if potential for groundwater impacts is a factor to be considered in the siting process, each subfactor related to groundwater impacts must be identified. For each of these subfactors, such as length of contamination path, hydraulic conductivities, capacity for natural absorption and attenuation and hydraulic gradient, a numerical value is determined through empirical study.

Once each of the potential sites has been evaluated with regard to each of the subfactors, the suitability of each site may be determined by the following equation:

$$S_j = \frac{\sum_{i=1}^n W_i S_{ij}}{\sum_{i=1}^n W_i} \quad S_{ij} =$$

the "combined" score for site *J* for a given set of subfactors, *S<sub>ij</sub>* is the score of the site *J* according to subfactor *i*, *W<sub>i</sub>* is the relative weight of subfactor *i* assigned by those conducting the siting process, and *N* is the number of subfactors making up a particular factor.

## REMOTE CONTROL DREDGING PIT HOG™

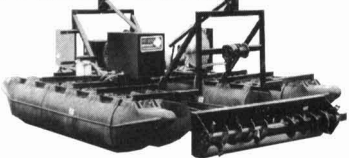

**Handle hazardous lagoon wastes without on board operator exposure!**

LWT Pit Hog™ remote control dredges pump noxious wastes safely. Electronic solenoids control direction, pump speed, depth, slurry agitation and the auger. Electric-hydraulic power provides soft start/stop and precise control. Lateral movement systems allow unattended operation. The Pit Hog has proven successful in applications throughout North America.

Call or write for **FREE Literature**

**LWT** LIQUID WASTE TECHNOLOGY®

Box 250, 422 Main St, Somerset, WI 54025  
FAX 715-247-3934 • Phone 715-247-5464

**Call Toll Free 1-800-243-1406**

Circle 44 on card.

## Solid as a Rock

Founded in western Colorado in 1962, Mount Sopris Instrument Company took its name from a nearby landmark. This prominent peak towers 12,953 feet... high above the others in the area and exemplifying our **soaring vision, high standards & unmovable commitment** to quality, service and reliability guaranteed with all **MSI geophysical logging systems, components and software.**

**MOUNT SOPRIS**  
Instrument Company

17301 W. Colfax Suite 285 Golden, CO 80401  
(303) 279-3211 FAX (303) 279-2730

Circle 45 on card.

You spend  
millions of  
dollars on  
environmental  
projects...

Circle 46 on card.

...and the measure  
of your success  
is based upon the  
accuracy of your  
analytical data.



Terra Consulting Group provides independent analytical data validation in a comprehensive report specifically designed for environmental managers.

Our original **pdq**™ software (Preliminary Data Qualification) enables us to reconcile, analyze and screen your analytical data package and diskette deliverable within 72 hours.

Learn about the details and benefits of **pdq**™ from the leaders in data validation.

**TERRA**  
CONSULTING GROUP

Baton Rouge, LA and Princeton, NJ  
504-769-1141

## Site Selection

This equation may be applied repeatedly to aggregations of factors starting from the lowest level of subfactors through an aggregation of all factors.

The putative advantage of a fuzzy set approach to site selection is that the "mechanical process of repeatedly using the fuzzy set equation is stochastic rather than professional judgment-based methodology."<sup>10</sup> In fact, a great deal of judgment must be used in the fuzzy logic process. Choosing the subfactors for site selection, the methodology for obtaining the numerical values for each subfactor and, most importantly, determining the weighting factor for each subfactor, involves a great deal of professional judgment.

Several methods for determining the weighting factor for each subfactor are available. These weighting factors can be

provided by law or regulation. These weighting factors also can be developed through surveys of expert opinions.<sup>11</sup> Ultimately, the relative scores of each site are compared to one another. For each factor, one site is judged to be equal, better or

worse than the other site. The better of the two sites is then compared with the next site until a site that may be considered the "best" is selected.

Fuzzy set processes are useful methods for assisting siting decision makers, but they are not the panacea academics argue. In fact, there

are more instances where professional judgment must be exercised using a fuzzy logic system than using the "gut reaction" method. The usefulness of fuzzy logic is to organize professional judgment and check arbitrary decision making based upon overemphasis on a single criterion or

*continued on page 149*

*"Siting large controversial treatment, storage and disposal facilities can benefit from the use of a quasi-governmental siting process."*

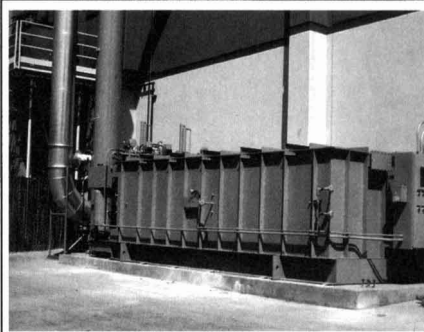

**ADWEST**  
TECHNOLOGIES, INC.

**TURNKEY  
REGENERATIVE  
AND CATALYTIC  
OXIDIZER  
VOC ABATEMENT  
SYSTEMS**

### POINT SOURCE APPLICATIONS:

- \* Flexographic Printing
- \* Flexible Packaging/Screen Printing
- \* Soil Vapor Extraction/Air Stripping
- \* Web Converting/Coating
- \* Web Offset Printing/Packaging
- \* Chemical Processing/Expanded Foam
- \* Paint Finishing/Varnishing
- \* Phenolic Composites
- \* Laminating/Textiles/Fabrics
- \* Semiconductor/Circuit Boards

### PRODUCTS/SERVICES:

- \* Retox Regenerative Thermal Oxidizers
- \* Katox Catalytic Oxidizers
- \* Thermox Thermal Oxidizers
- \* Shell & Tube Heat Exchangers
- \* PLC Controls
- \* Single Source Turnkey Installation
- \* Shop Assembled/Tested Systems
- \* Lease Finance Options
- \* TEL-MAX Telemetry Systems
- \* Over 300 Systems Installed

**TURNKEY OXIDIZER SYSTEMS FROM 100+ SCFM FLOWRATES**

**Call Today for a Free Catalog**

**ADWEST**  
TECHNOLOGIES, INC.

Corporate Office  
803 W. Angus Ave  
Orange, CA 92668  
Tel: (714)997-8722  
FAX: (714)997-8744

East Coast Office  
151 Trapping Brook Rd.  
Wellsville, NY 14895-9465  
Tel: (716)593-1405  
FAX: (716)593-6614



# Direct Push Technology: Concept Comes Of Age

*Sampling groundwater, soil and soil vapors,  
with little surface disruption, is possible  
with direct push technology.*

By Richard D. Saunders

**D**irect push technology is rapidly gaining a following of consultants and regulators alike. The technology has been around for many years but with today's greater emphasis on conserving assessment dollars, it is coming of age.

The greatest asset of direct push technology is its ability to facilitate the collection of substantive samples of groundwater, soil and vapor with minimal disruption of the soil. This reduces the production of investigation-derived wastes and minimizes the length of time required for sample collection, which ultimately lowers costs.

Direct push sampling technologies have been well-received because they often are faster and less expensive than other conventional sampling methods. Depending on the collection equipment, sampling depth and analytical system, between 10 to 30 samples may be collected and analyzed in an average workday. With direct push technology, the cost per sampling point usually is much less than that of conventional drilling and sampling. Also, since no soil is brought up to the surface during soil vapor sampling operations, there are no investigation-derived wastes requiring disposal.

However, the technology is not suitable for every site. A number of practical considerations must be considered, generally relating to site conditions and contaminants. When direct push technology is used to collect groundwater samples, soil or soil vapor, the dirt is pushed aside and not brought up to the surface, unlike hollow-stem auger drilling. During groundwater sampling, there is no development or purge water to store, analyze, transport and dispose. Wastes generated during drilling groundwater monitoring wells from well development and purging usually are drummed pending analytical laboratory results.

## Soil Boring Vs. Direct Push

Soil boring is time consuming and costly. A typical 4-inch diameter, 40-foot deep soil boring will produce up to four drums of soil cuttings and, if converted into a groundwater monitoring well, as much as three drums of development water. If the soil cuttings or groundwater are contaminated, disposal can become an expensive process. Disposal costs could range from \$75 to \$150 dollars per drum. For a typical site assessment of three soil borings and one groundwater monitoring well, disposal costs could add as much as \$3,000 to the

cost of remediation. Using direct push technology to collect samples may allow a 50 percent or more savings when compared to drilling and sampling, which could add another \$1,200 per day to assessment costs.

Sampling with direct push technology may use any of several systems including: hydraulic pusher systems, hydraulic hammer systems, electric rotary-impact hammers or hand-held slide hammers. Each sampling system has advantages and disadvantages, including limitations imposed by depth, terrain and site access.

Hydraulically driven, vehicle-mounted systems can reach depths of 100 to 150 feet below ground surface (BGS) or more, depending on the site-specific soil conditions. These systems are mounted on vans, light trucks and four-wheel-drive vehicles.

Cone penetrometer rigs, which operate from trucks weighing from 10 tons to 30 tons, may reach depths approaching 200 feet BGS.

Electric impact hammers reach greater sampling depths. Sometimes depths of 40 feet BGS are possible with electric hammers; however, 15- to 20-feet below ground surface should be considered maximum depths. The major advantage of this system is that it can be used in areas where it is not practical to use a vehicle (indoors and landscaped areas).

Hand-held and operated-slide hammers can penetrate the first few feet of soil but are usually limited to 4- to 6-feet below ground surface.

## Project Scope Decisions

Before selecting the sample collection methodology, all site-specific features should be discussed with the appropriate direct push technology contractors during the initial project scoping (see Chart 1, page 39).

When groundwater samples are collected, a retractable piston or drive point covers the hollow probe while it is pushed to the desired collection depth. The retractable piston/drive point is withdrawn when the desired sampling interval is reached. Groundwater is collected using a bailer, downhole pump or samplers. The collected samples are brought to the surface, containerized, sealed, labeled and cooled to preserve chemical integrity pending transportation to the analytical laboratory.

## Direct Push Technology

During soil sampling, a retractable piston or tip covers the sample collection device while the probe is pushed to the desired depth. Depending on the system, various diameter tubes may be used. Some of the larger diameter probes, which are capable of achieving greater depths, use standard split-barrel samplers. Many of the larger vehicle-mounted direct push systems also use a percussion system to assist the probe in penetrating pavements. Regardless of the diameter of the sampler, the retractable piston or tip is withdrawn when the desired sampling interval is reached. This allows soil to enter the sampler as it is driven further into the soil. The collected samples then are brought to the surface, sealed, labeled and cooled to preserve chemical integrity pending transportation to the analytical laboratory.

In soil vapor sampling, a retractable or drop-off tip covers the soil vapor inlet ports while the probe is pushed to the desired sampling interval. The probe is withdrawn a few inches or rotated to expose the vapor inlet ports. The ports are connected to a small diameter hollow tube (Teflon or Nylaflo) attached to a vacuum pump or similar device at the surface. A pump or other device draws soil vapor to the surface. After the system is purged, samples may be collected in small hypodermic-like syringes, Tedlar bags, Summa canisters or special soil vapor sampling loops or samplers. In any case, the sample is delivered to a fixed or mobile laboratory as soon as possible after collection.

Analytical data can be plotted to produce maps of the horizontal and vertical extent of soil vapor contamination and contaminated groundwater plumes.

Combining direct push technology with mobile analytical labora-

tories has become popular for in-field analysis of samples. During recent years, chemists and engineers have adapted gas chromatographs (GCs) comparable to commercial laboratory-grade GCs for field use and have been able to maintain the same calibration and quality assurance requirements as fixed laboratories. Detection limits are on the order of parts per billion.

The practical detection limits for field analysis using laboratory-grade GCs are sufficiently low to allow the environmental specialist to make informed, on-site decisions. These GCs are configured with a number of different detectors including photoionization detectors, electron capture detectors, electrolytic conductivity detectors and flame ionization detectors. Analytical methods similar to EPA Methods 418.1, 8010, 8015 and 8020 are generally used for petroleum hydrocarbons and chlorinated solvents.

### Conclusion

When properly phased, specific direct push methods can produce considerable assessment cost reductions by:

- Limiting the number of necessary soil borings and groundwater monitoring wells,
- Reducing investigation derived-wastes, and
- Increasing the speed of the investigation.

More intangible is the savings realized by the reduction of liability for the installation and maintenance of permanently installed groundwater monitoring wells.

*Richard Saunders is project manager for AeroVironment in Monrovia, Calif.*

# Shredders

- ✓ Reduce
- ✓ Recycle
- ✓ Recover



SHRED-TECH manufactures shredders and systems for

- Industrial Waste
- Hazardous Waste
- Product Recovery

Environmental responsibility can be profitable

Call SHRED-TECH  
1-800-465-3214

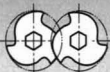

SHRED-TECH

Cambridge,  
Ontario, Canada

## ZERO CENTURION® ELITE CARRYING CASES Maximum Durability, ZERO Styling

Protection for Transporting  
Delicate  
Instruments



- Deep drawn, tempered aluminum alloy.
- Ultimate strength-to-weight ratio (4 times greater than cold rolled steel).
- Immune to cracking from aging or cold.
- Engineered foam, including anti-static.
- Custom interior/exterior options and finishes.
- Odorless, non-toxic and naturally EMI shielded.
- Water tight available.

**ZERO**

Zero Enclosures • North Salt Lake, UT • (801) 298-5900 • Fax (801) 292-9450

**Chart 1. Sample Collection Technologies Compared**

Technology	Procedure	Advantages	Disadvantages
<b>Groundwater Sample</b>			
Drill	Drill, install casing, develop well Purge well, collect sample in sampler	Can collect samples from greater depths Can penetrate tougher ground conditions	Generates cuttings Low productivity, 150-200 fpd Large crew required, 3-4 persons Requires well casings Generates development water Generates purge water
Direct Push	Push, collect sample in sampler Analyze at fixed or mobile laboratory	Does not generate cuttings Does not require well casing Does not generate development water Does not generate purge water Relatively high productivity, 300-400 fpd Small crew required, 1-2 persons Can get into restricted clearance areas	Cannot always get to same depth as drill rig May require coring prior to sampling Cannot resample same spot at a later date
<b>Soil Samples</b>			
Drill	Drill, collect samples in split spoon sampler Analyze at fixed or mobile laboratory	Can collect samples from greater depths Can penetrate tougher ground conditions	Generates cuttings Low productivity, 150-200 fpd Large crew required, 3-4 persons
Direct push	Push, collect samples in split spoon sampler Analyze at fixed or mobile laboratory Small crew required, 1-2 persons Can get into restricted clearance areas	Does not generate cuttings Relatively high productivity, 300-400 fpd	Cannot always get to same depth as drill rig May require coring prior to sampling
<b>Soil Vapor Samples</b>			
Drill	Drill, install soil vapor sample point, backfill Purge tubing, collect sample in sampler Analyze at fixed or mobile laboratory	Can collect samples from greater depths	Generates cuttings Low productivity, 150-200 fpd Large crew required, 3-4 persons
Direct Push	Push, purge tubing, collect sample in sampler Analyze at fixed or mobile laboratory	Does not generate cuttings Relatively high productivity, 300-400 fpd Small crew required, 1-2 persons Can get into restricted clearance areas	Cannot always get to same depth as drill rig May require coring prior to sampling Cannot resample same spot at later date



**HAZ-MAT CONTAINMENT CORPORATION**

**FREE!**  
**Federal Compliance Guide  
and Haz-Mat Brochure**

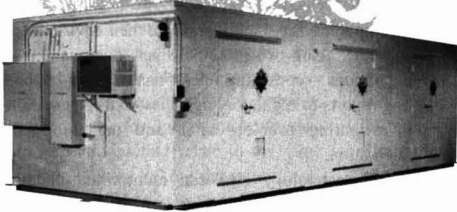

**Turn-Key and Cost Effective  
Hazardous Material Storage Buildings**



- Lockers and Buildings up to 400 square feet
- Drum, Pallet, IBC and Shelf Storage
- Explosion Relief Construction, Explosion Proof Electrical Equipment, Temperature Control and Specialty Applications

**MEETS OR SURPASSES ALL FEDERAL  
BUILDING, ENVIRONMENTAL AND SAFETY CODES**

HAZ-MAT CONTAINMENT CORPORATION, INC.  
712 Bancroft Road, No. 216, Walnut Creek, California 94598  
Tel (510) 943-5250 • Fax (510) 210-1054  
**(800) 943-6510**

Circle 51 on card.

**Save more than 50% On  
Your Groundwater  
Monitoring Program!**

Avoid drilling a series of monitoring wells. Monitor from several depths within the same borehole.

Positively engineered packers effectively seal each monitoring zone. No cross-contamination risk.

**Continue to save time and money** in quick and easy ongoing monitoring.

Call for a cost comparison against your current monitoring program.

**Solinst** *High quality instrumentation*

*Solinst Canada Ltd. 35 Todd Road, Georgetown, ON L7G 4R8  
(905) 873-2255, (800) 661-2023; Fax: (905) 873-1992*

**Waterloo Multilevel System**

Circle 52 on card.

# Bringing Together Pictures And Words

*Geographic Information Systems  
can open up a new dimension  
to integrate computer graphics and data*

By William Douglas

**D**uring the past 10 years, Geographic Information System (GIS) technology has undergone a significant evolution in capabilities. It has been used for a wide variety of spatial analysis and information management problems. Now it can serve as the glue for binding together disparate organizational information within a common framework. Four graphical computer technologies relate to GIS:

- Automated Mapping (AM) – A digitalized approach for mapping that has replaced much of the world's manual cartography.
- Facility Management (FM) – A computerized approach for managing industrial facilities and infrastructure.
- Computer Aided Design (CAD) – Refers to automated drawing, which has virtually replaced manual drafting.
- Data Visualization (three dimensional) – A high-level use of graphics to display surface and subsurface features and conditions.

Automated mapping and computer aided design are graphic displays of the earth's surface and electronic engineering drawings. A graphic representation of a natural or manmade object is a useful construct for management and analysis purposes, but the construct is strengthened when data (numbers, text) and other information (images, photos) are linked to the graphics. These technologies were not originally designed to associate the graphics with databases, although recent developments have begun to blur the boundaries between these methods and those of GIS and facility management.

## **GIS, FM Applications**

GIS has been oriented toward two-dimensional maps and layer-based designs applied to displaying attributes such as demographics, biological species, parcels, wetlands and zoning. GIS map layer overlays

are used in environmental applications to identify preferred site locations or for excluding areas where industrial sites are likely to cause excessive environmental impact. The software processes data elements associated with the map object layers (lines, points, polygons or gridded cells) to produce composite maps or to create new graphic products.

FM is used for layout drawings of industrial facilities or municipal infrastructure such as pipelines, streets, electrical lines and other spatially identifiable objects. Articles in the drawings, such as pumps, hydrants, valves and transformers are related to specification data describing the equipment (horsepower, flow rate, size, manufacturer, serial number and more) and to operational data such as installation date and maintenance activities.

Corporations typically organize their environmental activities along two principal lines: compliance with regulations – collecting operational data and submitting reports to regulatory agencies; and remediation – investigating problem sites and managing their restoration.

GIS technology also can incorporate planning, training, maintenance, inspections and auditing into facility management programs. However, many organizations experience a common problem. Although compliance and remediation issues often deal with common facilities, they are managed by different departments. Compliance and remediation are dealt with as separate issues. This separation can produce institutional barriers and impede information flow within the organization.

Other parts of the company such as engineering, operations and human resources deal with facility issues and have needs that could be supported by better information sharing. Experience has shown that disintegrated information management tools often are used, purchased or developed as point solutions to discrete

*William J. Douglas is a senior program director with ERM Program Management Company, a member company of the ERM Group, based in Exton, PA.*

regulatory needs rather than as part of an integrated information management strategy. These conditions have resulted from the growth in regulations. This has placed a severe burden on the capacity of the organization to address the associated information requirements.

### The Strategy For Industry

A number of corporations are beginning to integrate their environmental departments with their safety and health organizations, forming an Environmental Safety and Health (ESH) department. This integration can be supported by an approach that applies GIS and FM concepts to coordinate related information. Graphic representations of facility-oriented objects can be used to associate environmental data with spatial position (sampling locations, emission points or control equipment). CAD drawings managed by the engineering department can be enhanced with the intelligence of an object-based GIS, which associates locations with relevant environmental information.

Facility maps, building drawings and process diagrams can be associated with various data types, including database tables, schedules, text images and photographs. This approach provides access to information by allowing the user to point at maps and drawings to produce subsequent data types and to invoke menu commands on these data types. Compliance and remediation data can be integrated within the same framework. Furthermore, the same drawings provide a basis for integration with other corporate entities that relate to the same facilities, such as linking the safety manager's incident data with the maintenance manager's failure and repair data.

### GIS Prototype For Integration

During the late 1980s, experiments with preliminary components of the above concepts were conducted using a Workstation, object-based GIS called Graphics Data System (GDS). In the early 1990s, working with systems analysts from Graphic Data Systems Corp., a prototype software system called EDGE had a broad range of integrated functions and was developed on a stand-alone workstation to demonstrate this concept. The sys-

tem has evolved to broaden its capabilities, is now called EDGE2 and includes the following components:

Engineering workstation, personal computers, local area network, object-based GIS, relational database management system, imaging system, regulatory text database, regulatory compliance database, remediation database, document management system and a cost/scheduling system.

Figure 1 on page 43 illustrates an example of the system application for a fictitious corporation (XCORP) in which the user can drill down from general to specific information through a geographic user interface (geo-GUI). A map of the United States identifies the XCORP plant locations, illustrated in the upper left hand sector of the figure. Pointing to a location

(environmental manager, phone number, address and more) and produces a detailed facility map.

Pointing to a specific building on the facility map pulls up a menu identifying the floors in the building. Selecting a specific floor produces a floor plan in which one or more industrial processes are identified

as blocks. By pointing to the process block (Process ABC), a detailed diagram shows the equipment, material flow, air emission locations and wastewater discharge locations. By selecting an air emission location, a database table identifies all of the emission test results for that stack. Pointing to a room on the building drawing produces a chemical inventory table or report for the room. Contamination data can likewise be viewed. By pointing to sampling locations, concentrations can be extracted and displayed on the drawing as numerical values or modeled as isopleths of constant contamination.

Figure 2 on page 43 shows the results of another sequence in which the base map is used to select and display stored images. A photograph of a waste site is obtained by pointing at the waste site on the facility drawing. A material safety data sheet (MSDS) image also is displayed by choosing a building or site and selecting from the menu of MSDSs that are available for that site and then paging through the multi-page document.

*"Pointing to a location brings up its identity, the environmental manager, phone number, address and more, and produces a detailed facility map."*

# The Invisible Second Skin



**SkinTECT**  
is an effective,  
cost efficient and risk  
reducing solution for  
all your hazardous  
exposure concerns

**SkinTECT**  
protects from...

- |               |            |
|---------------|------------|
| Acrylics      | Benzene    |
| Cement/Lime   | Graphite   |
| Drying Agents | Herbicides |
| Iodophor      | Resins     |
| Lye/Solvents  | Toluene    |
| Formaldehyde  | Xylene     |
- and many more

Contact Chris Buell  
for Information or Samples

**GOODWAY USA**  
14506 Arrow Hwy, Baldwin Park, CA 91706

**(800) 349-7546**  
FAX (818) 856-3378

THE *FID* EVERYONE'S  
BEEN WAITING FOR!

## New *MicroFID*<sup>™</sup> from Photovac

*For superior detection  
of VOCs in Fugitive  
Emissions or  
Environmental  
applications*



- The smallest, lightest datalogging FID available.
- Out-performs the competition... at a lower price.
- Integrated EPA M-21 Windows<sup>®</sup> based software package.
- Class I Division I Groups A,B,C & D Intrinsically Safe.

**PHOTOVAC**

Photovac Monitoring Instruments  
25-B Jefryn Boulevard West, Deer Park, NY 11729  
Tel: (516) 254-4199 • Fax: (516) 254-4284

MicroFID is trademark  
of Photovac Incorporated.  
Windows is a registered trademark  
of Microsoft Corporation

### Dimensional Data

During the 1980s and early 1990s, integration of GIS, database and imaging technologies required workstations to handle the variety of applications. Today, technologies have emerged to facilitate the integration within a PC configuration. However, Unix workstations continue to be the platforms of choice for most serious GIS/FM applications.

Software tools such as ArcView 2 and Integraph MGE are available as integrating platforms to facilitate system integration in a graphic facility interface operating mode. Many lower end PC-based systems (desktop GIS) such as MapInfo and Atlas GIS among others, are capable of application to the role of integrating platforms. The specific functionality and the look will differ, depending on the selected GIS and the associated database management system and imaging tools.

### Data Visualization

High level three-dimensional data visualization is being integrated into the prototype by providing standard exporting routines to move data from the drawings and database tables to a Unix workstation having functions designed specifically for displaying information in appealing formats. These same workstations are applied in the film industry to integrate real film with graphics, or to alter real film to obtain desired effects.

Applications of three-dimensional graphics are most appropriate in subsurface contamination for visualizing topography, groundwater, soil stratigraphy and contamination plumes. Once

# MANIFEST ASSOCIATE

Software Simplifying  
Hazardous Waste Management.  
Accurate Record Keeping  
Ensuring E.P.A./E.P.D. Reporting  
And Compliance.

- ▲ Automatic container labeling
- ▲ Intuitive, windowing interface
- ▲ Custom tailored installations

computer solutions... complete compliance

For a demo disk or product information

Call  
**1-800-844-1400**

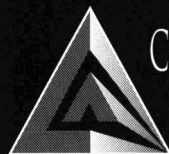

COMPUTER **ALLI**

6000 Dawson Boulevard, Suite E  
Norcross, Georgia 30093



Figure 1

the data has been modeled, the user can rotate the graphic to view it from different elevations or perspectives; slice the graphic to produce different subsurface features; fly through the graphic; and display time-dependent changes in an animated sequence. Figure 3 on page 44 illustrates applications of a visualization tool called VIS-3D to show contamination along with surface and subsurface features. This technology has been effective in communicating complex site



Figure 2

conditions to managers, regulators, lawyers, judges and juries.

Graphics-based technologies are being applied extensively to remedial and compliance issues at increasing levels.

• For a major pipeline, a system integration plan was developed to define how its compliance and remediation organizations could integrate with other organizational entities over Local and Wide Area Networks using GIS, database management systems, imaging

**NEW!**

## Dual ELIMINOx<sup>®</sup> treatment systems help you meet or exceed Clean Air Act requirements

**99% Removal Efficiency or Greater**

**Maximum Corrosion Resistance**

**Eliminates Orange-Brown Plume**

**Dual will work with you to:**

- Identify your problem
- Determine the necessary degree of control
- Select the best method of control
- Select the proper chemistry
- Design for minimum air volume

**NETPRO CORPORATION Dual Division**  
 1550 INDUSTRIAL DRIVE, OWOSSO, MI 48867  
 (517)725-8184, FAX (517)725-8188

Circle 55 on card.

## Haz-Safe™ First with...

**LARGEST FM APPROVED BUILDINGS**

- **24" Design System™™** up to 14' widest x 70' longest x 16' highest buildings saving real estate with multiple rooms instead of individual sheds, and better use of vertical space.
- **Modular Building System™™** for unlimited size and expansion with sump/roof caps and concealed fasteners.
- **Protected Crown and Cradle™™** tubular steel skeleton, 10 gauge steel skin, porcelain enameled steel interior, exceeds all codes.
- **Haz-Safe Mat Handling™™** crane hoist inside and overhead doors for quick loading.

**HAZ-SAFE™**  
Buildings by Design

a division of  
**CID Associates, Inc.**  
**PH: (412) 842-2130**  
**FAX: (412) 845-7834**  
 P.O. Box 606  
 Leechburg, PA 15656-0606

\* U.S. Patent 5,191,942, 5,285,617, 5,301,479 Others Pending

Circle 56 on card.

## Dimensional Data

- For a large manufacturer, a structured design of AutoCAD process flow drawings was conducted to include equipment, sampling locations and emission points. These drawings are processed to extract data and populate fields in an associated database, ensuring consistency between drawings and data and promoting data integrity and quality.

- For a large chemical plant, VIS-3D was used to integrate topography, site planimetrics, chemistry, groundwater and stratigraphy data to create dramatic visual representations of current site conditions and to model and visualize the impact of alternative remediation approaches.

- For the Washington, D.C., metro rail system, GDS was used to display and analyze information relating to a municipal incinerator ash site along the right-of-way. Three alternative routes were analyzed by displaying hazardous chemical concentrations, cross sections and excavation volumes to support the realignment design of the line to achieve an economically viable and regulatory compliant design.

- For a major airport facility, an integrated FoxPro data manage-

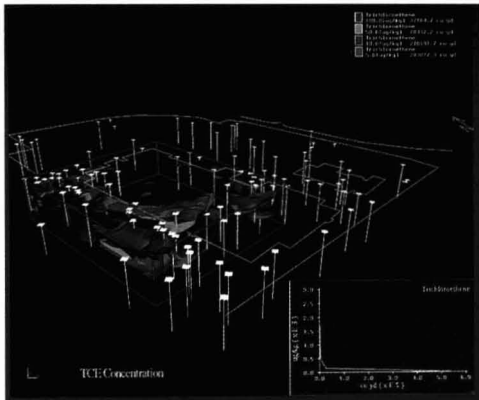

Figure 3

ment system was applied to track samples from the work plan stage to the loading of results into the project database. Arc CAD, an AutoCAD/Arc/INFOR integrating utility, was used to display data results graphically. Database and GIS information products were to be submitted to the federal agency in electronic format when the project was completed.

While fully integrated applications of the EDGE approach are not yet visible in the industrial sector, components are falling into place and applications are appearing in publications and at GIS conferences. The evolution toward these approaches will accelerate.

Current directions in information technology provide a wealth of information and considerations for the environmental manager. The movement is toward PCs and networks with distributed database management and information sharing among various users and corporate entities. Point solutions associated with a specific regulation are giving way to integrated systems dealing with the environmental requirement as a whole, or to integrated information sharing in ESH systems.

*continued on page 65*

## ENVIRONMENTAL INSURANCE FOR:

**Environmental Contractors;  
Asbestos Abatement Contractors;  
Engineers & Consultants;  
T.S.D.F.'s; General Industry;  
Hazardous Waste Transportation;  
Financial Institutions; Property  
Owners, Managers & Developers**

- ▶ Contractors Pollution Liability
- ▶ Pollution Legal Liability
- ▶ Asbestos Liability
- ▶ Property Transfer Pollution Liability
- ▶ Underground Storage Tank Liability
- ▶ Professional Liability
- ▶ General Liability
- ▶ Automobile Liability
- ▶ Workers' Compensation



Jardine Environmental Services  
A Division of  
Jardine Insurance Brokers Inc.  
801 S. Figuerda St. Suite 700  
Los Angeles, CA 90017  
Contact  
Lisa K. Murdoch

**TEL: (213) 599-4088**

## Oil in Water / Soil Analyzers

Horiba offers trace oil analyzers to accommodate applications requirements from continuous on-line to portable and laboratory analysis. These analyzers use an infrared analysis technique which is not affected by color or turbidity.



For more information call **1-800-4-HORIBA.**



**HORIBA INSTRUMENTS INC.**  
17671 Armstrong Ave., Irvine CA 92714  
1-800-4-HORIBA, 714-250-4811, FAX 714-250-0924



# In-Line Flow Control Blocks Risky Leaks

*Excess flow valves work alone or in conjunction with expensive monitoring equipment to prevent accidental releases of hazardous materials.*

By William A. Nolan

Recently in Boynton Beach, Fla., 500 pounds of chlorine gas was accidentally released from a water treatment plant. This accident forced the 4,000 residents of Boynton Beach to evacuate their homes. Area schools also shut down as the cloud drifted west and another 1,000 residents left the area.

Investigators blamed the chlorine gas leak on a line failure. The chlorine ate a hole in a copper plug in a gas regulator. Workers were unable to detect the leak until it became dangerous.

When excess flow valve technology is applied in the environmental and hazardous materials industry, potentially dangerous leaks can be detected downstream. The in-line device stops accidental release and uncontrolled flow of toxic, volatile or flammable pressurized liquids or gases used in process flow industries such as chemical processing, water treatment and semiconductor manufacturing.

The Clean Air Act Amendments of 1990 Section 112(r) addresses "Accidental Release of Hazardous Materials." The act lists 16 substances exhibiting dangerous toxic, flammable, volatile and dispersible characteristics. Among them are: chlorine, anhydrous ammonia, ethylene oxide, anhydrous hydrogen chloride and sulfur trioxide. The act requires EPA's administrator to create a list of the top 100 substances that pose the greatest risk of causing death, injury or serious adverse effects to humans, health or the environment.

In the same section, paragraph 7.B.11 items I, II and III require owners or operators of a "Stationary Source" of these hazardous materials to prepare a "Risk Management Plan" to detect, prevent and

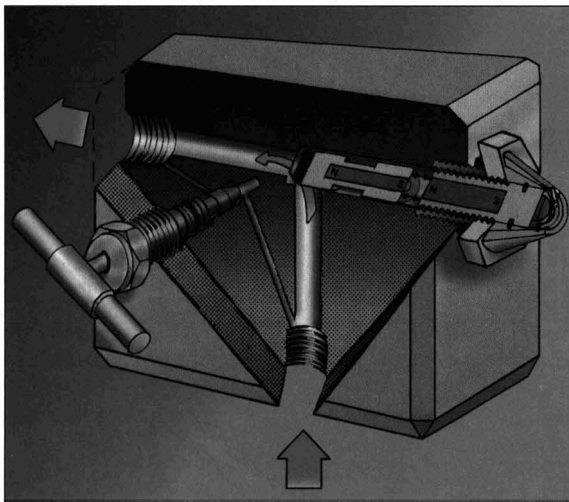

minimize the impact of accidental release. The three necessary components of the plan include:

- Hazard assessment,
- Prevention program, and
- Response program.

Any facility with greater than threshold amounts of these hazardous materials is required to register the plan with EPA. Many of those detection and prevention programs are elaborate systems including gas analyzers, fume detectors, flow meters, flow switches, valve actuators, pressure switches, solenoids, double piping and/or braided hoses.

The excessive flow valve's (EFV) in-line control can sense when excessive flows are downstream based on a preset norm. As a result, it shuts down flow at the valve or suppresses it to an acceptable level when excess flow occurs.

## Responding To Accidental Releases

This device also may have helped residents of Coral Springs, Fla., in October 1994. A chlorine leak from a Coral Springs Water Works plant woke more than 5,000 residents and forced them from their homes. For 10 hours, firemen and utility workers waited for the sun to burn off the noxious gas cloud. Accident investigators blame an improper temporary line repair for the leak.

The device comes in standard materials including brass and 316ss. Optional materials are 316L and Monel. Port sizes are 0.018-, 0.025-, -0.054-, 0.50- and 0.75-inch FNPT. The product line is designed for actuation points in the ranges: 0.004 to 20 gmp (liquids) and 0.018 to 130 scfm (gas). Maximum pressure in the high pressure unit is 6,000

# Now there are two great reasons to switch to Foxboro.

New  
2-Year Warranty



## Twice the detection. Twice the warranty.

The new TVA 1000 from Foxboro is the first over-the-shoulder portable vapor analyzer to offer both photoionization and flame ionization detectors in a single instrument.

Now it comes with a special 2-year warranty on standard parts and labor, for an even greater value.

### **Increase productivity while you lower costs.**

With dual detectors, you can now monitor both organic and inorganic vapors simultaneously. So efficiency and productivity are increased. You no longer need to carry two separate instruments to check out a site. And you detect a greater number of vapors per scan.

All this means that you reduce monitoring time and expenses, while saving the cost and trouble of purchasing and maintaining a second analyzer.

### **Put analytical power at your fingertips.**

Our high-capacity sample pump ensures fast, 2-second detector response with quick, clear display. And the TVA 1000 features a compact, ergonomic design, so you can easily carry it anywhere. A large keypad ensures simple and straightforward operation, with or without gloves.



Simplified data logging software, triggered instantly by a thumbswitch on the hand-held sample probe, makes testing easier and faster, too.

### **Take it anywhere, with confidence.**

Thanks to the latest packaging technology, the TVA is durable and weathertight to NEMA 3 specifications, even under tough field conditions. Its FM performance certification further confirms its accuracy and dependability. And the TVA is also FM approved for intrinsically safe use in Class I, Division 1, Groups A, B, C, and D hazardous locations.

If you need more great reasons to switch to our unique dual-detector TVA 1000, call your Foxboro representative. Or contact The Foxboro Company, Foxboro, MA 02035. Phone toll-free: 1-800-521-0451.

The Intelligent Automation People  
**FOXBORO**<sup>®</sup>

A SIEBE COMPANY

## Leak Detection

pounds per square inch. The temperature range for all units is -40 to 200 degrees Fahrenheit. The EFV comes in three different models with numerous features. The specific application will determine which unit should be selected. Important variables include: media, line sizes, pressures, temperatures and planned flow rates. To determine the proper valve, answer these questions:

- Does an accidental release of the hazardous substance require complete "positive" shut-off?
- If case actuation occurs, can someone easily reach the valve?

### Excess Flow Valve Functions

Flow enters the unit and makes a right angle to the outlet port across the nose of a magnetic piston. The piston is held in place by attraction to the adjusting screw magnet. A pressure differential is created by flow across the piston. When the differential is great enough, the piston slides to the seat at the outlet port. The flow rate at which the piston actuates can be changed externally by turning the adjusting screw, thereby changing the piston's relationship to the flow stream.

Different installation attitudes change the sensitivity of the valve. The adjustable feature becomes more critical when deviating from the normal design attitude. The unit should be calibrated in the attitude in which it was installed.

After the valve reaches the activation point, the piston slides to its seat. A bleed allows a small flow downstream. If the line is turned off upstream or downstream, the bleed will equalize the pressure, the piston will reset and the valve will open.

After the valve reaches the activation point, the piston slides to a

soft seat. An "O" ring provides a positive seal. The source pressure will hold the valve closed. The valve is reopened by closing the source and venting the inlet to atmosphere or pressurization of the downstream piping. This is usually done with a by-pass.

The unit is similar in function to the standard unit with positive shut-off. After activation, this unit has its own internal by-pass. A handle on the side of the unit can be turned to open the inlet to the outlet port, thereby equalizing the pressure and opening the valve.

### Specific Applications

Under pressure, anhydrous hydrogen chloride (HCL) is a liquid, and at atmosphere, it becomes a volatile gas. When the gas comes in contact with moisture, it becomes a powerful corrosive liquid condensing on whatever it touches. That includes human lungs. Inhalation has serious health implications and consequences. As one of the specifically targeted hazardous substances, accidental release of HCL must be prevented and must be dealt with immediately.

### Case Studies

• A manufacturer of Dextrin uses HCL in a direct material input. It is stored outside the plant on a pallet in-600 pound cylinders called tonners. They are connected to 0.054-inch hose that feeds the pressurized gas into a manifold which introduces it into a reactor in three separate places.

The plant operators specified the excess flow valve as a part of their risk management plan, prevention program and response plan for accidental release. The excessive flow valve protects the employees in the



Brushless, Auto Flow Control  
Outdoor HI-VOL Air Sampler

- High-Volume Pumps
- Stack & Fume Hood Sampling Systems
- Brushless Portable Hi-Vol Samplers
- Low-Vol Air Samplers
- Cabinet Mounted Pump Systems
- Mobile Cart Systems
- Carbon Cartridges
- Silver Zeolite Cartridges
- Air Flow Calibrators
- Instrument Weather Houses
- Combination Paper and Cartridge Holder

**Call or Write for our latest Catalog**

Complete Sampling System Design and Engineering Available

**HI-Q Environmental Products Co.**

7386 Trade Street  
San Diego, CA 92121

PHONE: (619) 549-2820  
FAX: (619) 549-9657

Circle 62 on card.

**YOUNG**

# Meteorological Instruments

**Sensors to Measure:**

- Wind Speed
- Wind Direction
- Peak Gusts
- Temperature
- Delta T
- Dew Point
- Relative Humidity
- Precipitation

**R. M. YOUNG COMPANY**  
2801 Aero Park Drive, Traverse City, MI 49684 U.S.A.  
Tel: 616-946-3980 Fax: 616-946-4772

Circle 63 on card.

## Mobile Treatment Services

- Water Purification
- Wastewater Treatment
- Chemical Separations
- Trained Technicians
- State of the Art Lab
- R&D Staff

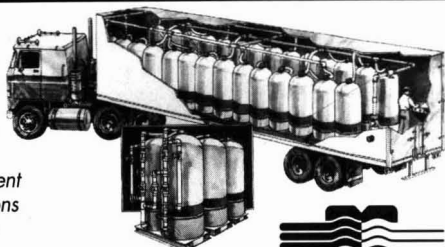

**800-238-3028**

**MOBILE PROCESS TECHNOLOGY**  
Since 1989

**2070 Airways Blvd., Memphis, TN 38114**  
**Fax: (901) 743-2361; (901) 744-1142**

Circle 59 on card.

**\$495** Annual Subscription

30 DAY MONEY-BACK GUARANTEE

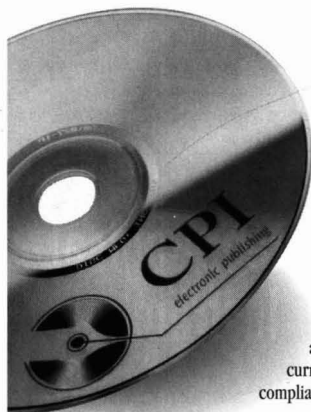

FEDERAL ENVIRONMENTAL & SAFETY AUTHORITY

# FESA

## Regulatory Compliance CD

The most complete, current and user-friendly regulatory database with all current Federal Register and multiple CFR titles integrated on one CD.

The FESA Environmental and Safety Regulatory CD continues to lead the industry with instant, affordable access to all Federal environmental regulatory data, current EPA and Labor press releases and more than 40 compliance manuals from government agencies.

FESA is the only electronic regulatory data base to put all this—and more—on a single CD ROM. No other environmental and safety regulatory database is as complete or as easy to use.

Use FESA once and you'll know why.

- *Full-Text Federal Register*: Final Rules, Proposed Rules, Notices, Preambles, Consent Decrees & Public Notices.
- *Complete Code of Federal Regulations (CFRs)* updated with the latest Federal Register changes and current to last GPO printing date. Includes Titles 10, 21, 29, 30, 33, 40 & 49 and applicable parts of most other CFRs.
- *More than 40 Leading Compliance Manuals* for: RCRA, OSHA, CERCLA, EPCRA, TSCA and others.
- *Includes Federal SW-846 Analytical Testing Methods Manual* for Solid Waste.
- *Multi-Platform*: Windows (WYSIWYG), MS DOS and Full Network Support.
- *No Reformatting*—Import FESA data into any wordprocessing software, without having to reformat anything.
- *The Only Regulatory Database* with time- and money-saving *Concept Trees* that allows you to preview a document before bringing it on-screen. Even novice users can quickly understand the content and structure of the FESA database.
- *Multiple Search Options*: Query by Concept Trees... Menu Assisted... Boolean... Command Based Query... Concept, Range, Phrase and Field.
- *Easy to Use*: Ultra-fast full text search and retrieval software. Hypertext links on the fly. Easily view and manipulate any FESA data—using all your usual word processor tools, fonts and commands.
- *Weekly, Bi-weekly, Monthly & Quarterly Subscriptions*.
- *Free Bi-weekly Newsletter* for all subscribers.

Ask About Our New Expanded State Coverage.

**800-808-3372**

**CPI**  
electronic publishing

7505 East Main Street • Suite 400 • Scottsdale, Arizona 85251 • Tel (602) 994-4560 • Fax (602) 994-4456

Circle 64 on card.

## LEAK DETECTION

plant from catastrophic release of the substance. Because of the corrosive nature of the media, a regular schedule for verification of operation is an important part of their plan. An EFV was selected for immediate positive shut-off when an excessive flow is detected.

In another example, polymers are some of the basic materials used to add to wastewater to eliminate heavy metals before discharge. As such, polymers are typically inert. Ethylene oxide is a basic building block of polymers. However, this unsaturated low molecular weight hydrocarbon is extremely volatile. Under pressure it remains in a liquid state. At atmosphere, it becomes a gas. When combined with air, it spontaneously bursts into flames.

Ethylene oxide coming from a petroleum cracking plant is normally transported by rail car. It is moved under pressure from the rail car on a rail sliding through connections feeding into a processing facility manufacturing soaps, lubricants and other surfactants.

The plant uses the excessive flow valve as an important part of its plan to prevent and respond to accidental release of ethylene oxide. The EFV protects the plant from a flash fire because of an uncontrolled release of the oxide into the environment. It shields employees from the threat posed by fire and exposure to the blistering material. Because of the volatile nature of the material and the severity of the results should such a release occur, the valves are checked and changed regularly.

Pressurized aqueous hydrogen chloride was stored in a rail car. It was covered with a blanket of gas that prevented it from combining with other gases in the car. The gaseous blanket was continuously monitored by an analyzer to ensure proper content and composition.

A positive shut-off EFV is used in-line with the gas analyzer to protect it from liquids that may come into the line should the rail car be overfilled. The excessive flow valve senses a significant change in viscosity of the media or a simple change in phase upstream of the valve. When this occurs, it immediately shuts off flow to the gas analyzer.

Excessive flow valves also can be used to protect expensive monitoring equipment. As demonstrated above, the EFV can serve as a primary mechanical deterrent against accidental release of hazardous materials. In addition, it works in other capacities with other equipment to protect and perfect the media itself.

William A. Nolan is president of CTE Chem-Tec in Deerfield Beach, Fla.

EP

The 12th Annual

# HAZMACON<sup>®</sup> '95

## The Environmental Solutions Expo

April 4-6, 1995

San Jose Convention Center, San Jose, California

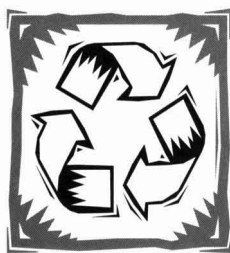

### HAZMACON offers practical solutions in the following areas:

- Hazardous materials & waste management
- Industrial and solid waste reduction, treatment and disposal
- Air emissions/pollution control
- Groundwater and site remediation
- Recycling
- Employee health and safety
- Medical/laboratory waste and more...

### HAZMACON '95 will include all of the following and more...

- 30 conference sessions designed to cover current industry topics.
- 29 environmental training seminars targeted towards various experience levels.
- Over 200 companies featuring the latest advances in technology and state-of-the-art products and services.
- Meet with federal and state regulatory agency representatives who are prepared to answer your compliance questions.

### Don't Be Left Out!

Thousands of business professionals will find solutions to their environmental problems.

### Save Money! Register Early.

Early registration can save you money. For more information, fill out the coupon below and mail or fax to ABAG at (510) 464-7970.

- YES! Please send me a FREE HAZMACON '95 conference program  
 YES! Please send me HAZMACON '95 exhibiting information

NAME \_\_\_\_\_

TITLE \_\_\_\_\_

COMPANY \_\_\_\_\_

ADDRESS \_\_\_\_\_

CITY / STATE / ZIP CODE \_\_\_\_\_

PHONE / FAX \_\_\_\_\_

Return coupon to ABAG, P.O. Box 2050, Oakland, CA 94604-2050  
or Fax to (510) 464-7970. For immediate information on exhibiting please call (415) 964-2050.

EP

Managed by **SHO** (415) 964-2050

Sponsored by **ABAG** Association of Bay Area Governments  
(510) 464-7960 • (800) 827-ABAG Outside the San Francisco Bay Area

# SCR Controls NO<sub>x</sub> From Ship's Stacks

**A** California-based company has reduced nitrous oxide emissions from its ships by 80 to 90 percent. USS-POSCO Industries (UPI) in San Francisco has equipped a fleet of four ships with selective catalytic reduction (SCR) technology. The vessels travel from Korea to the Bay.

During the 1980s, the company transported most of its hot band steel coils by rail. Its transportation emissions limits were based on output that occurred between 1985

and 1987. The baseline was calculated without additional ship emissions. To expand its fleet, UPI needed to either reduce transportation emissions to remain at the baseline or pay for additional air pollution credits if it exceeded the limits.

UPI chose the former option.

This task proved to be formidable. According to a spokesman with the Bay Area Air Quality Management District (BAAQMD), a ship traveling one-way through the Bay releases about 1,100 pounds of nitrous oxide emissions in district waters. After UPI commissioned a study by the California Maritime Academy, it found that without nitrous oxide control, the company would far exceed its daily and annual permit limits.

UPI came across two Danish companies that used SCR technology on diesel engines. In 1989, the company decided to install the technology in two new ships and began shipping the steel coils later that year.

In the San Francisco Bay Area district waters, UPI faces stringent emissions controls. To comply with these rules, UPI workers switched the main engine fuel to an ultra-low sulfur fuel.

Nitrous oxides are reduced when ammonia is injected into the main engine exhaust gas. The gas mixture passes through a catalyst where nitrogen oxides are converted to nitrogen and water vapor.

Although allowed to run the ships in district waters, UPI had a few technical hurdles to overcome. First, the amount of nitrous oxide reduction was directly depen-

dent on the amount of ammonia added to the mixture. Even though a great deal of nitrous oxide is reduced when high levels of ammonia are added, the amount of unused ammonia in the cleaned exhaust also increases. This "ammonia slip" can increase or decrease when sudden changes in load occur. However, when the load of the ship is steady, ammonia slip is less than 10 parts per million.

According to Kelly McMahon, UPI division manager of environment and safety, reducing nitrogen oxide levels can be done only when temperatures hover between 320 and 400 degrees C. This is necessary to prevent the reaction of ammonia with sulfur dioxide. If ammonia did react with sulfur dioxide, ammonia sulfate would form on the catalyst and degrade it.

When UPI used a low sulfur fuel, it expanded the temperature window to 270 degrees C.

One of the biggest challenges in sustaining a 90 percent nitrous oxide reduction rate was maintaining exhaust gas temperature within the window. Reducing the sulfur content in the fuel, heat tracing the SCR vessel and modifying the process controls made it possible for ammonia injection to take place during 90 percent of the entire trip.

Since most of the SCR technology had been used on stationary sources, UPI had to develop a way to operate the technology on the mobile source. Company engineers had to take into account the hull efficiency, propeller curves, ship's draft and current as well as bridges and obstacles on the shore. After this, they could begin to implement the technology on the entire fleet.

McMahon said that reducing air emissions can be accomplished without sacrificing engine and ship handling performance. UPI is taking advantage of the ships' capability to operate within the Bay Area and turn around at the dock.

"It took us some time to get it down to an art," McMahon said. However, after five years of intense research, UPI currently operates the only commercial freighters with SCR on board.

Sandra Lopez, former supervising engineer and manager of the Toxic Section at the BAAQMD, said that the SCR technology on mobile sources worked better than the district expected it would.

"They (UPI) did something they didn't have to do and they had to prove it every step of the way," she said. **EP**

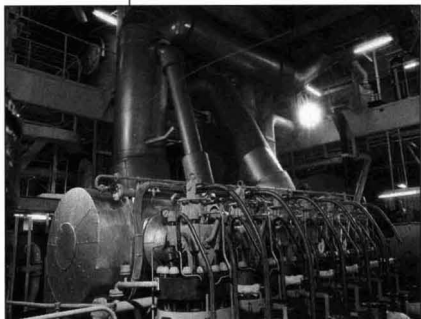

# "one Clean Operation"



Maybe not every NIRO High Temperature Fluid Bed Incineration Plant is surrounded by a residential community, but there is no reason why they can't be.

- **MUNICIPAL & INDUSTRIAL APPLICATIONS**
- **ODORLESS / SMOKELESS / CLEAN**
- **EFFICIENT / LOW ENERGY USAGE / LOW MAINTENANCE**
- **MEETS ALL EPA 503 REGULATIONS**
- **MEETS ALL STATE REGULATIONS FOR AIR EMISSIONS**



Member of the  
GEA Group **GEA**

NIRO Inc. • 9165 Rumsey Road • Columbia, Maryland 21045  
(410) 997-8700 • Fax (410) 997-5021

Circle 65 on card.

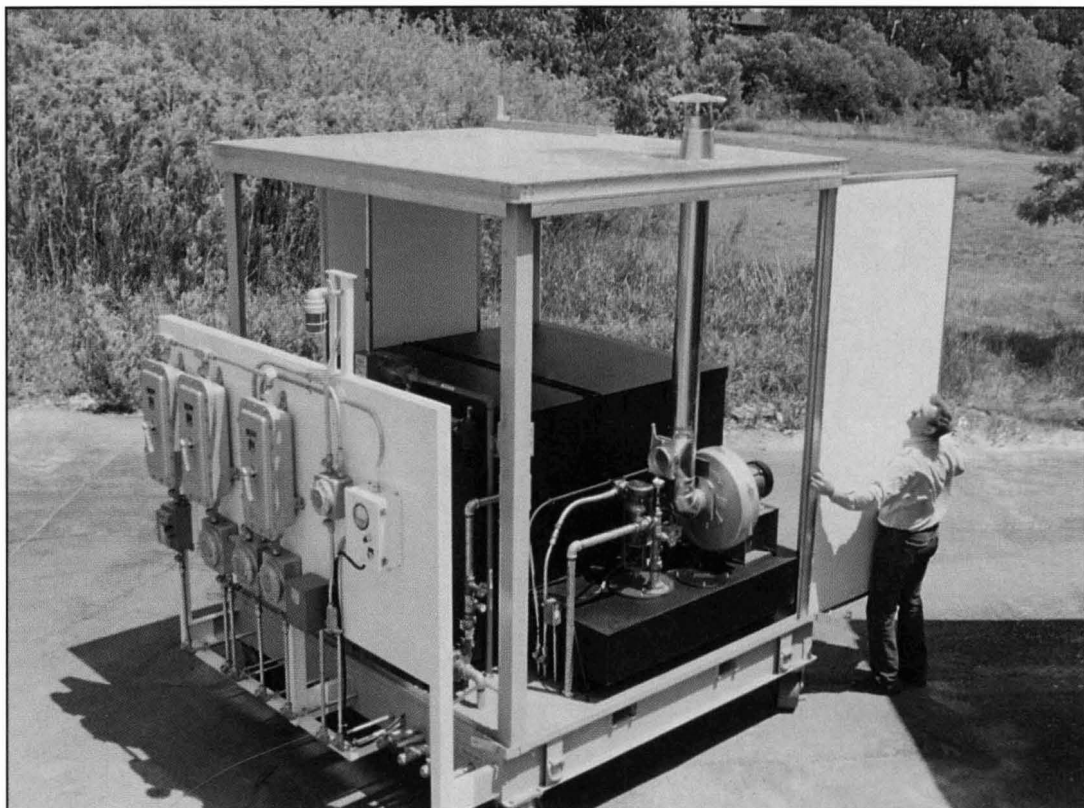

# Engineered for UPTIME

While conscientious maintenance is an essential ingredient of uptime, what kind of design creates an expectation of only 95%? We say one that is not good enough.

You wouldn't buy a car that you knew would be in the shop a day and a half of each month. You wouldn't buy a watch that lost an hour and 12 minutes a day. At least not intentionally.

Ejector Systems' On-Site Platform is engineered to raise your uptime expectations. Our own proprietary designed and manufactured process components combined with our unique, rugged enclosure gives you single source responsibility.

53 pound enclosure panels, that slide in a track like a patio door, yield unobstructed access to any component on a minimum foot print. And we do it your way with over 200 possible combinations at the most competitive prices.

Price is a component of excellence in engineering. With over 100 units built, the On-Site Platform is living proof that price and quality are different sides of the same coin and not mutually exclusive.

Ready for reliability and savings?

Give us a call at **1-800-OIL-LEAK** or circle our number on the Reader Service Card.

## *The On-Site Platform allows you to choose:*

- GroundWater Pumping Systems
- Removable Sliding Walls
- Air Stripper
- Oil/Water Separator
- Soil Vapor Extraction
- Air Sparging
- Carbon Absorption
- Filtration

**Call 1-800-OIL-LEAK for free information.**



*Pioneering Product Recovery and GroundWater Remediation*  
910 National Avenue, Addison, IL, 60101 fax 708.543.2014



# Review, Reconsider Your Presentation

**W**hile new training regulations always seem to bring debate and confusion, their silver lining is work, as in job security. I can't wait to see what this year brings.

In the meantime, let's review. Have you met your Hazard Communication, RCRA, HAZWOPER, PPE training requirements? If that's the case, then it's time to change or polish up your programs. Trainers must remain practiced and fresh to be effective. So, while we patiently await the silver lining, here's some tips for the new year.

**Review your knowledge base.** Few things will guarantee the failure of any presentation more surely than a lack of knowledge of the subject at hand. Therefore, review your

topic goals, historical basis, conditions related to need, technical details and job application.

**Reconsider your audience.** Most people spend too much time worrying about their presentation, and not enough time considering those who control the effect – the audience:

- How will you relate to the age, gender and educational level of your trainees?
- Are your session settings conducive to learning or do they create hostility; are they noisy or uncomfortable?
- Are you dealing with factions aligned along different sides of an issue?

If so, research, plan and work them to your advantage.

*Michael J. Cherniak,  
CET, is vice president of  
Environmental Training  
Consultants Inc., in  
Corvallis, Ore.*

**INTRODUCING THE ALL NEW...**

## TRIBOGUARD SERIES OF BAGHOUSE MONITORS

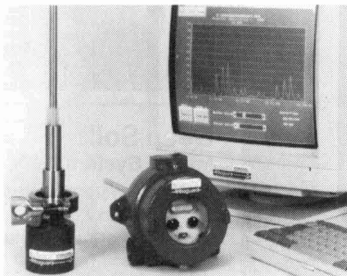

The analog **TRIBOGUARD II** system is available with a 4-20mA output and **PRE-VENT**,<sup>®</sup> the new Dual Alarm system that gives you an early warning alarm *BEFORE* a high emission is reached. The all new design will meet the requirements of Parametric Monitoring, so maintenance can use it to reliably detect broken bags, while the plant Continually Demonstrates Compliance. Ask about Auburn's new **PC Communications & Software** which will help you not only log data, but also **LOCATE** the failed filter in your dust collector. Produced by the pioneers in Triboelectric Technology.

**auburn**<sup>®</sup> INTERNATIONAL

Eight Electronics Avenue, Danvers, MA 01923  
1(800) 255-5008 FAX: (508) 777-8820 (508) 777-2460



OUR BOOK WOULD BE A  
"BEST SELLER"

IF IT WASN'T  
**FREE**

ORDER YOUR **FREE**  
ALL NEW 1995

**Art's MFG. & SUPPLY**  
**SAMPLING EQUIPMENT**  
CATALOG

**1-800-635-7330**

# In-Situ Stabilization At Any Depth



## Backhoe Operated Sludge Stabilizer

The BOSS system utilizes a specially designed rotary backhoe attachment to add solidification reagent subsurface to sludge impoundments.



Geo-Con's newly developed in-situ solidification technology offers homogeneous mixing at high production rates resulting in increased productivity and lower treatment costs.

## Effective • Proven Wet or Dry

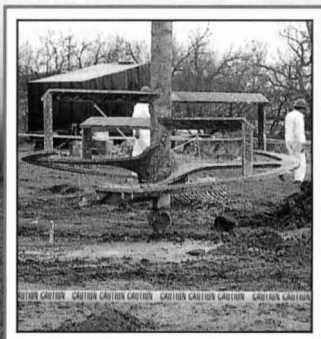

## Shallow Soil Mixing System

The SSM system utilizes a single mixing auger (up to 16 feet in diameter) to perform in-situ stabilization of soils or sludges to depths of 40 feet without excavation.



Geo-Con's SSM system also has the ability to perform in-situ vapor extraction and capture any volatile organics that would emanate from an in-situ stabilization operation.

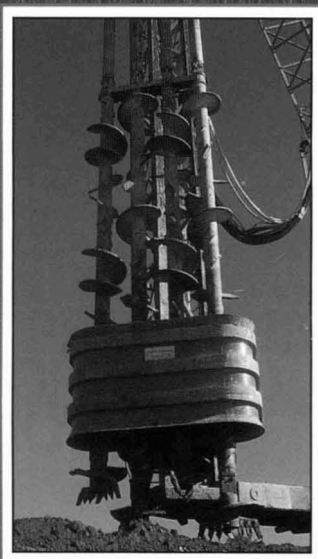

## Deep Soil Mixing System

The DSM system utilizes a multiple mixing auger system to perform in-situ stabilization of soils to depths of 150 feet without excavation.

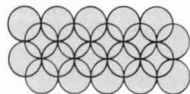

Geo-Con's DSM system has been proven effective in the U.S. EPA's Superfund Innovative Technology Evaluation (SITE) program for the in-situ stabilization of PCB contaminated soils.

## In-Situ Experience

Geo-Con, Inc., a national remedial construction company, has developed in-situ solidification and stabilization into a demonstrated state-of-the-art technology. For more information on your upcoming project, write or call:



**Geo-Con, Inc.**  
Geotechnical Construction

4075 Monroeville Boulevard  
Corporate One Building II, Suite 400  
Monroeville, Pennsylvania 15146

Texas Office (817) 383-1400  
California Office (510) 887-2002

Florida Office (813) 647-5888  
New Jersey Office (609) 772-1188

Circle 69 on card.

© 1991 Geo-Con, Inc.

## Establish a comfortable style and dress one notch up from your audience.

Once the audience has been dissected, you should have a good feel for their needs, perspective and goals. An audience will veto a good presentation if it doesn't touch them personally.

**Define realistic outcomes.** Most presenters shoot for the moon with a list of objectives and walk away disappointed when they can't meet all of them in a session. You might take an hour to discuss various PPE issues, and if one listener gets a new-found respect to wear goggles each time they mix caustic soda, I'd say you did just fine.

**Identify audience benefits.** As much as most people are interested in doing "the right thing," it often seems that the thing is a lot easier to do when it benefits them directly. Three planning suggestions are noted:

- Reach your audience by using the words "you" and "your" often in the presentation.
- Make a list of direct audience benefits and make sure all of them are mentioned at some point or another.
- Involve the audience by using handouts, exercises or group problem-solving activities.

**Structure your presentation.** Follow Cicero's Rules of Discourse, which have worked well for a couple thousand years:

- Get the audience's attention with a story, anecdote or dramatic statement.
- State the facts through a background of the topic.
- Discuss the agreements and disagreements.
- State your case through points, logic, emotion and acknowledgement of legitimate concerns.
- Conclude your presentation by calling your audience to specific action.

**Present yourself well.** Don't serve steak and lobster on a paper plate. Fortunately or unfortunately, what a trainer says is colored by how people see him or her. Most often, training success is achieved by combining equal measures of knowledge, audience respect, humility and humor. Establish a comfortable style, never apologize for speaker shortcomings and, as a general rule, dress one notch up from your audience – but only one.

**Present your information.** The first two minutes of appearance, posture, attitude and anxiety level can make or break your presentation. Practice and preparation will ensure that you get through this fine. Here are a few pointers for the remaining 98 percent of the time:

- Change your voice tone, volume and inflections.
- Use pauses to think before you speak. They grab the audience's attention.
- Appear comfortable by being comfortable. Wear comfortable clothes and alternate between standing (to make points) and sitting (to lead discussions).
- Move around and address your audience directly.
- Gauge audience attention by using questions that you have prepared before the session.
- If you don't know the answer to a question, say so. If you promise to get back to somebody with an answer, get back to them.

**Evaluate your session.** A simple approach is to start with the positive and list what went right. Then ask what needs to get better? Take some immediate hand notes and place them with your materials as notes for next time. Finally, read and assess the class evaluations. So, don't sit and fret about the future. I'm sure that by the time you complete this review process, there will be a new training regulation with which to comply. **ED**

**Eco Waste Solutions**  
Environmental Equipment Manufacturer

Think you need magic to destroy and reduce waste by 90% at your site?

**Before:** Solid waste loaded in the Oxidizer Chamber in 1 ton bales.

**After:** Volume is reduced by over 90% and the remains are the metal bands from the bales and inert white ash.

**Tel: 1-800-368-7546, Fax: 905-385-7839,  
296 Northshore Blvd. West, Burlington, Ontario, Canada L7T 1A4**

As a part of  
our ongoing  
commitment  
to the  
readers of  
Environmental  
Protection  
magazine,  
Stevens  
Publishing  
introduces the  
Stevens  
Compliance  
Library.

# Environmental PROTECTION



## Book of the Month

In the process of developing the comprehensive features and articles you've come to expect from Environmental Protection magazine, our writers and editors encounter many quality publications that may be of interest to you. Beginning with this issue, EP will compile a list of relevant, helpful and often hard-to-find publications and make them available.

### Hazardous Materials and Hazardous Waste Management

*A complete treatment regarding all aspects of this important area providing readers with regulations and statutes of OSHA, the Clean Air Act, the Clean Water Act, RCRA, Superfund and others. It features an overview of the various topics along with field applications.*

*The authors present workplace management techniques for hazardous materials and waste and include exposure assessment, personal monitoring, worker protection, building safety and administrative requirements. Environmental contamination assessment and remediation techniques for groundwater, soils and air, and chemical reduction and waste minimization strategies are also covered in depth. 408 pages.*

ORDER NO. 1-54676-3

Price \$64.95

### Remedial Processes for Contaminated Land

*Cleaning up land which has been contaminated by earlier industrial activity is a matter of major interest. Eight leading authorities in the UK, USA and Europe contribute chapters on the technology currently available and on likely future developments. Malcolm Pratt, industrial environment director of the consultants Cremer & Warner, edits and provides a foreword. 148 pages.*

ORDER NO. 0-85295-310-0  
Price \$30.00

### Controlling Volatile Organic Compound Emissions from Industrial Wastewater

*Descriptions of the sources of organic containing wastewater, VOC emission estimation procedures for treatment and collection system units, and available VOC emission control strategies. Although the book applies particularly to organic chemicals, it is also applicable to a broad range of other industries. 362 pages.*

ORDER NO. 0-8155-1261-9  
Price \$48.00

### Transportation of Hazardous Materials

*A guidebook to understanding and applying the Department of Transportation (DOT) Hazard Materials Regulations (HMR) to the shipment and handling of regulated hazardous materials. It provides a general reference that can be used by industry managers to provide training on hazard awareness and to assist in job specific training. 262 pages.*

ORDER NO. 0-8155-1350-X  
Price \$54.00

# Please send me the titles indicated at right.

MAIL ORDER INFORMATION TO:  
Stevens Publishing Corporation, P.O. Box 2573, Waco, TX 76702-2573

VISA  MC  AMEX  CHECK/MONEY ORDER

Card# \_\_\_\_\_ Exp. Date \_\_\_\_\_  
Signature \_\_\_\_\_  
Name \_\_\_\_\_  
Company/Dept. \_\_\_\_\_  
Address \_\_\_\_\_  
City/State/Zip \_\_\_\_\_  
Phone# \_\_\_\_\_  
134850151

QTY	ORDER NUMBER	TITLE	UNIT COST	TOTAL
SUBTOTAL				
For TX, IL, GA, NJ, DC, MI residents add applicable sales tax.				
Shipping and handling, please add \$7.00 for the first book and \$3.00 for each additional book =				
TOTAL				

CLIP and MAIL

## Hazardous Chemicals and the Right to Know

An overview of Title III of the Superfund Amendments and Reauthorization Act (SARA), designed to provide state and local governments and residents with the legal framework to obtain information about potential chemical hazards. The book demystifies complex codes, makes right-to-know statutes accessible to citizens, and avoids costly enforcement actions for industry. 340 pages.

ORDER NO. 0-07-026906-8  
Price \$69.00

## Biotreatment of Industrial and Hazardous Waste

A complete guide to evaluating, selecting and applying state-of-the-art microbial techniques to biologically treated industrial and hazardous waste. You'll find field-tested guidelines for evaluating various treatment types, selecting methods for waste products, determining the cost-effectiveness of various treatment methods, conducting initial and follow-up site evaluations and ensuring safety. 331 pages.

ORDER NO. 0-07-037554-2  
Price \$60.00

## Natural Systems for Waste Management and Treatment

Biologically-based systems for handling waste are garnering international attention as a more reliable, less costly alternative to energy intensive mechanical systems. This pioneering guide features the most recent advances in the use of wetlands and aquatic systems, the treatment of sludges and other areas of this rapidly developing field. 400 pages.

ORDER NO. 0-07-060982-9  
Price \$55.00

## Waste Containment Systems, Waste Stabilization and Landfills

The most comprehensive design reference currently available on remediation techniques, waste disposal methods and all types of waste containment systems. The book also provides you with expert coverage of new waste stabilization technologies that convert non-solid toxic waste to inert solids. 608 pages.

ORDER NO. 1-57536-4  
Price \$74.95

## Statistical Methods for Groundwater Monitoring

A new and authoritative book that illustrates how to effectively use statistics in groundwater detection monitoring at hazardous and municipal waste disposal facilities and satisfy USEPA Subtitle C and D regulations. It presents material critical for human health and the protection of the environment, and addresses the needs of industry by providing methods to minimize both false positive and false negative rates. 286 pages.

ORDER NO. 1-58707-9  
Price \$69.95

## The Environmental Dictionary

This book collects in one volume all definitions from the Code of Federal Regulations (CFR) and the Federal Register related to environmental regulations. All 5,250 definitions are reproduced as they appear in the CFR and every definition is cross-referenced to the Section of the CFR where it is found. 996 pages.

ORDER NO. 0-0471-11247-X  
Price \$95.00

## Environmental Remediation Contracting

Learn how to effectively deal with legal issues, technology and contracting principles involved in the environmental cleanup process. This book is a step-by-step guide through the remediation process which offers sample contract terms and clauses, remediation strategies, cost allocation techniques and more! This book has everything you need to manage your remediation process. 456 pages.

ORDER NO. 1-57325-6  
Price \$125.00

## Encyclopedia of Environmental Control Technology — High Hazard Pollutants

This new volume in the *Encyclopedia of Environmental Control Technology* series focuses on the effects of various toxic agents on human health. *High-Hazard Pollutants* covers research, testing, remediation and removal methods for these poisons. In addition, workplace environmental hazards such as heat and noise are given concentrated attention in several chapters. 704 pages.

ORDER NO. 0-87201-291-8  
Price \$155.00

## Resources and References Hazardous Waste and Hazardous Materials Management

This guide book provides references and resources for the complex field of hazardous waste and hazardous materials management. Each section includes a list of annotated bibliographies of the most recent books by major publishers as well as established, standard references. Following the annotated titles, are additional references of books and documents. 295 pages.

ORDER NO. 0-8155-1351-8  
Price \$64.00

## RCRA Regulatory Compliance Guide

Written especially for companies that need an easy-to-read guide to the Resource Conservation and Recovery Act (RCRA), and information on how hazardous waste regulations impact day-to-day business operations. 354 pages.

ORDER NO. 0-8155-1321-6  
Price \$64.00

## Solvent Substitution for Pollution Prevention

This book provides up-to-date information on current technologies and practices in solvent substitution for those involved in handling, using or managing hazardous and toxic solvents, based on an international workshop held in 1990. The subject matter of the papers included covers a wide range of solvent substitution activities. 335 pages.

ORDER NO. 0-8155-1319-4  
Price \$48.00

## Handbook of Leak, Spill and Accidental Release Prevention Techniques

This book is designed to provide technical guidance to prevent leaks, spills or other accidental releases of hazardous substances from fixed facilities that produce hazardous substances, store them, or transfer them to and from transportation terminals. The audience addressed includes managerial and supervisory personnel as well as "hands on" personnel. 487 pages.

ORDER NO. 0-8155-1296-1  
Price \$76.00

# 1-800-207-3535

Call the Stevens Compliance Library  
To Place Your Order TODAY!  
Circle 71 on card.

Or FAX Us Your Order For Faster Service: 1-817-862-7076  
ACT TODAY! These titles are limited and moving quickly.

**Environmental  
PROTECTION**

# Compliance Resources

9 out of every 10 questions regarding regulatory compliance are found right in the pages of manuals printed by government agencies. But finding the ones that apply to your specific area can often be expensive and time consuming.

To better serve our subscribers, Stevens Publishing has located these often-obscure and most-always expensive manuals and reprinted them in their entirety at a substantial savings to you.



## **RCRA Inspection Manual – New for 1994!**

This new RCRA manual for EPA's compliance inspectors gives you the checklists, procedures, priorities, and protocol of an inspection from entrance to exit. This EPA guide includes a summary of the regulations.

#35-7272, Softcover, 392 pp., Nov. 1993, **\$29.95**  
Compare at \$125.00

## **NPDES Compliance/Inspection Manual**

Technical specifics in this EPA manual clarify how to comply with the regulations. Instructions for inspectors on procedures and a description of the NPDES program provide an insider's look at compliance.

#35-6733, Softcover, 134 pp., May 1988, **\$29.95**  
Compare at \$69.00

## **Chemical Information Manual**

Documented and described in this pertinent manual are over 800 chemicals found in the workplace. Indexed by synonyms and CAS numbers, the information includes chemical information, health effects, exposure limits, and more. This reference for OSHA compliance inspectors also describes OSHA's sampling and analysis methods.

#30-2436, Softcover, 671 pp., July 1991, **\$39.95**  
Compare at \$61.00

## **OSHA Technical Manual**

Heavily revised and greatly expanded, the latest OSHA manual used by OSHA inspectors covers inspection guidelines for various sampling techniques and procedures, heat stress effects, noise measurements and hearing conservation evaluations, back disorders and injuries, indoor air quality, hospitals, technical equipment, chemical protective clothing, and much more.

#30-6748, Softcover, 324 pp., Apr. 1993, **\$24.95**  
Compare at \$79.00

## **NPDES Best Management Practices Manual**

This EPA manual is an indispensable tool for any industry under regulation. Detailing not only what BMPs are, but also how they work, this handbook's utility is enhanced by industry-specific BMP plans. Included are regulatory policies, information on inspections, training, recordkeeping, and important resources (national, regional, state, and more) for determining Best Management Practices.

#35-6732, Softcover, 198 pp., Oct. 1993, **\$19.95**

## **Control Technologies for Hazardous Air Pollutants**

This manual is used by EPA technical personnel both to answer questions from potential permit applicants and also to evaluate and review permit applications from facilities with potential hazardous air pollutant (HAP) emissions. Discussions cover complete design and cost considerations for thermal and catalytic incineration, flares, boilers/heaters, carbon adsorption, absorption, condensers, fabric filters, electrostatic precipitators, and Venturi scrubbers. Throughout this EPA handbook are calculation sheets, effluent characteristics for emission streams, potential HAPs and emission sources for various industries, comparisons and cost factors of the control technologies, and much more.

#35-4277, Softcover, 260 pp., June 1992, **\$24.95**  
Compare at \$73.00

## NIOSH Pocket Guide to Chemical Hazards

Packed with data, this chemical listing includes chemical exposure limits, health effects, target organs, when to use a respirator or personal protective clothing, a physical description of the chemical, and immediate dangers to life or health. Appendices list NIOSH and OSHA carcinogens, and index synonyms and trade names as well as CAS numbers.

#35-6464, Softcover, 246 pp., Dec. 1991, **\$24.95**  
Compare at \$58.00

## Multi-Media Investigation Manual

The increasing number of multi-media investigations make this EPA manual essential for the facility outputting waste, emissions, or effluent regulated by more than one law. Acts included are RCRA, CWA, CAA, SWDA, TSCA, FIFRA, EPCRA, and CERCLA. Checklists, forms, guidelines, and other tips and techniques for the inspector can help you in your own inspections.

#35-6646, Softcover, 250 pp., March 1992, **\$24.95**  
Compare at \$73.00

## NPDES Industrial Permit Abstracts 1993

Successfully submitted industrial permit abstracts from the field help you wade through your own permitting process. Use pertinent sections from these abstracts compiled by the EPA's Office of Water for guidance. Appendices with abbreviations, parameters, and lists are a quick reference to fulfill your permitting information needs.

#35-6472, Softcover, 482 pp., Oct. 1993, **\$34.95**

## Industrial User Permitting Guidance Manual

From the EPA's Office of Water, this manual reveals the ins and outs of the IU permitting process. Learn when you need a permit, what information you need, what steps you should take, how to avoid common pitfalls on permit applications, what monitoring and reporting requirements are, and when waste hauler permits come into play. Avoid delays by getting IU permit answers here.

#35-4876, Softcover, 266 pp., Sept. 1989, **\$24.95**  
Compare at \$62.00

## Good Laboratory Practices Manual

Know the questions TSCA and FIFRA inspectors will ask! Checklists cover health effects testing, recordkeeping, standard operating procedures, worksheets, and more. This EPA manual includes the necessary information for effective self-audit and problem prevention.

#35-4576, Softcover, 504 pp., Nov. 1993, **\$39.95**  
Compare at \$48.00

## Guidance Manual for the Preparation of NPDES Permit Applications for Storm Water Discharges Associated with Industrial Activity

This straightforward discussion comprehensively covers individual application requirements and permits, and includes important technical support for specific elements of the permit application forms. This EPA manual allows firm control of the application process using a permit application checklist and a diagram identifying which forms to use. Included are instructions on evaluating non-storm water discharge, estimating discharge flow rates and volumes, collecting storm water discharge samples, and more.

#35-4676, Softcover, 208 pp., Apr. 1991, **\$24.95**  
Compare at \$62.00

## Storm Water Management for Construction Activities: Developing Pollution Prevention Plans and Best Management Practices

Clearly written with detailed illustrations and concise reference materials, this manual helps facilities develop a storm water pollution plan for industrial sites. Navigate the stream of information with charts, illustrations, application forms and their timetables, and data sheets.

We've added the EPA's Summary Guidance primer spelling out the sequential steps for development and then implementation, as well as special requirements.

#35-7962, Softcover, 302 pp., Oct. 1992, **\$27.95**

## Storm Water Management for Industrial Activities: Developing Pollution Prevention Plans and Best Management Practices

Clearly written with detailed illustrations and concise reference materials, this manual helps facilities develop a storm water pollution plan for industrial sites. Navigate the stream of information with charts, illustrations, application forms and their timetables, and data sheets.

We've added the EPA's Summary Guidance primer spelling out the sequential steps for development and then implementation, as well as special requirements.

#35-7964, Softcover, 414 pp., Oct. 1992, **\$29.95**  
Compare at \$62.00

## Description and Evaluation of Medical Surveillance Programs in General Industry and Construction

While some employers know that OSHA is considering a medical surveillance standard for all workplaces, few will know what it will contain. An Advanced Notice of Proposed Rulemaking for a general medical surveillance standard in September 1988 led to this OSHA survey on current medical surveillance programs, their purposes, and their results. These findings clearly spell out how employers use medical surveillance programs, how some employers link their program to other risk reduction programs, and what medical surveillance program features benefit employers.

#30-3367, Softcover, 350 pp., July 1993, **\$24.95**

## OSHA Field Operations Manual for Inspectors

Know what to expect before, during, and after an OSHA inspection! Written for OSHA compliance inspectors, this OSHA manual details how to conduct inspections and identify violations. Use sections on handling citations, penalties, imminent danger, fatality/catastrophe investigations, complaints, and referrals to prevent problems at your facility.

#30-6783, Softcover, 440 pp., Aug. 1993, **\$29.95**  
Compare at \$85.00

## Recognition and Management of Pesticide Poisonings, 4th Ed.

This vital reference lists the main active ingredients and brand names of toxins, as well as step-by-step treatment procedures for 1750 pesticides. Know basic toxicology, methods to confirm exposure, principal symptoms and signs of poisoning for quick recognition and response to possible pesticide poisonings.

#35-7677, Softcover, 214 pp., March 1989, **\$19.95**  
Compare at \$52.00

## Building Air Quality: A Guide for Building Owners and Facility Managers

Prevent and resolve indoor air quality (IAQ) problems with this guide from the EPA's Indoor Air Division. This handbook pinpoints the basic factors affecting IAQ and outlines the necessary steps and skills in developing an IAQ profile for problem prevention, as well as diagnosing and mitigating existing problems. Appendix topics include the impact of HVAC systems, asbestos, radon, moisture/mildew/mold, resources, essential forms, and more.

#35-2274, Softcover, 246 pp., Dec. 1991, **\$24.95**  
Compare at \$58.00

# 1-800-727-7573

## or FAX Your Order 1-817-662-7076

### ACT TODAY!

These Titles Will Be Available Only While Quantities Last.

## YES,

Please send me the following Compliance Manuals indicated below.

Mail Order Information To:  
Stevens Publishing Corp.  
P.O. Box 2604  
Waco, TX 76702-2604

VISA  MC  AMEX  CHECK / MONEY ORDER  BILL ME

Card# \_\_\_\_\_ Exp. Date \_\_\_\_\_

Signature \_\_\_\_\_

Name \_\_\_\_\_

Company / Dept. \_\_\_\_\_

Address \_\_\_\_\_

City / State / Zip \_\_\_\_\_

QTY	ORDER NUMBER	TITLE	UNIT COST	TOTAL

SUBTOTAL

For TX, IL, GA, NJ, DC, MI residents add applicable sales tax.

Shipping and handling, please add \$7.00 for the first book and \$3.00 for each additional book =

To expedite your order, **CALL 1-800-727-7573**  
or FAX your order to **1-817-662-7076**.

TOTAL

# Methyl Bromide Users Search For Science

*Workers, neighbors and the ozone are protected by regulation from this chemical, but those needing it complain that a solid foundation is lacking for the rules.*

By Eric D. Winegar

**A**lthough not yet featured on "60 Minutes," the pesticide methyl bromide is gaining widespread attention because of its central position in debates about worker health and safety, environmental toxics exposure and global ozone depletion.

Methyl bromide has been a key component in a variety of agricultural operations since 1932, and though relatively unknown, is used in more than 100 applications ranging from fumigation of the soil before planting strawberry seedlings to termite control in homes and other structures. Both raw and processed foods are included in this list.

The importance of this chemical in these uses underscores the controversy. Recent developments in toxicology assessments coupled with the new-found concern over depletion of the ozone layer have met this importance head-on. However, there is evidence that the regulatory apparatus may be moving ahead of the science, leading to suggestions for more consideration of a solid scientific basis in estimating the efficacy of industrial and governmental actions.<sup>1</sup>

## Worker Health, Safety

During fumigation activities, workers typically attach large bottles of methyl bromide liquid to heaters which, through the vaporization of the liquid or with a pump, force the gas into the location being fumigated, either an enclosed space or into the soil.

The final concentrations are high — dosage rates typically are expressed in ounces per 1,000 cubic feet for enclosed chambers or pounds per acre for soil treatment — ranging up to 13,000 ppmv for fumigation chambers and up to hundreds of pounds per acre for soil application. At these levels, it is expected that workers are potentially exposed to high levels of the gas.

The exposure limit used most in the past has been the Occupational Safety and Health Administration's permissible exposure limit of 5 ppmv for an 8 hour time-weighted average (TWA).<sup>2</sup> However, a recent re-evaluation of this level in California has forced this limit downward, with *de facto* limits of 0.630 ppmv for an 8-hour TWA.<sup>3</sup>

Due to this re-assessment, California users of methyl bromide have examined their practices and developed

ways to minimize worker exposure as well as off-site exposure.

Several of the state's studies, conducted by users and growers, have shown that the range of applications is even more widespread than first imagined, and that a blanket regulation is not feasible because of that diversity. Most of the data collected showed relatively minor impacts to exposure scenarios, leading to changes in label permit conditions to minimize that impact. These modifications have been adopted, although some growers and users find those conditions restrictive. Buffer zones in which no entry was permitted for a fixed time period and minimum heights of exhaust stacks were part of these changes.

One study showed that for dried fruit commodities, the average exposure to workers during the period of high exposure potential (the actual introduction of the methyl bromide gas into fumigation chambers) had an average TWA exposure of 0.160 ppmv,<sup>4</sup> 25 percent lower than the target value of 0.210 ppmv. The majority of this exposure is because of one commodity, which having a high oil content, absorbs more of the gas. A recent follow-up study at this processing plant shows that the previous high exposure potential has been mitigated by changes in handling practices, such as a higher ventilation rate in the plant, with values decreasing to an average of 0.1 ppmv or less.

Besides the development of more detailed usage specifications listed in the application permit conditions, these exposure studies have led to a deeper understanding of how the amount of gas used is the main determinant of worker exposure. Concurrent with this understanding, large fumigation activities (greater than 1,000 lbs) now are more closely regulated.<sup>5</sup>

## Environmental Exposure

After the commodity or field has been treated with the methyl bromide dosage, the chamber or field is aerated to remove the gas. The treatment period is relatively short — from two to 24 hours. In addition to the protection of workers from exposure in fumigation operation, the assessment of exposure to others in the vicinity of these operations has been a goal of the California studies.



Stack emission measurements have been conducted concurrently with downwind ambient air measurements to document the dispersion of the emitted gas and to derive protective buffer zones for public exposure. The ambient data collected has been used to calibrate the Industrial Source Complex Short Term model used in dispersion calculations.<sup>6</sup>

This calibration step has appeared successful, however, some of the assumptions used in the model may have been overly conservative. When coupled with the inherent conservatism of the model, the protective buffer zones calculated are large. To avoid exposures greater than 500 ppbv over a 1-hour period, for a 250,000 cubic foot chamber injecting 1,000 pounds of gas, the protective buffer calculated has a radius of 6 miles from the chamber. These buffer zones and the notification required under California's Proposition 65 have driven the agriculture industry to challenge the rules behind these calculations. The final court decisions have not been rendered. A decision to uphold the Proposition 65 guidelines will require notification of the public within those

buffer zones whenever a release of methyl bromide is planned.

### Ozone Depletion

The ozone layer depletion debate has entered current vernacular, with the chlorofluorocarbons accounting for much of the attention. However, because of its apparent higher ozone-destroying efficiency (20 to 60 times higher than chlorine),<sup>7</sup> bromine atoms may contribute up to 25 percent of the springtime Antarctic stratospheric ozone losses even though the amount of inorganic bromine is less than 1 percent of the chlorine concentrations.<sup>8</sup> An assessment of global ozone depletion attributes from 5 percent to 10 percent of the loss to methyl bromide.<sup>9</sup>

These factors have been recognized in the movement to phase out ozone-depleting substances, which resulted in the Montreal Protocol.<sup>10</sup> Under this agreement, the ozone-depleting potential (ODP) of methyl bromide is listed at between 0.44 and 0.69.

Section 602 of the Clean Air Act requires EPA to list methyl bromide as a Class I ozone depleter since it has a ODP greater than 0.2. This designation forces the 1994 freeze of



**IF OUR PUMP  
WERE ANY SIMPLER,  
YOU COULD BUY IT  
AT THE DRUGSTORE.**

Simplicity of design makes for a reliable pump. Now, there's an easy, cost-effective way to pump contaminated liquids to the surface for treatment. The down-well controlled pneumatic Evacuator II pumps dependably day after day, providing uncompromising performance. Use it in top-loading designs for free phase products for a pumping rate of 4.8 gpm. Or use it in top- and bottom-loading designs for dissolved phase products at 10.0 gpm. Quicker air exhausting allows faster cycling and increased pump output. Each system includes an air regulator, 5 micron filter with auto drain, 4" well clincher and Swagelok connectors for easy and secure hose attachment. For more information, contact your local distributor or contact Longyear at the address below.

**BRAINARD•KILMAN™  
EVACUATOR II  
PUMP**

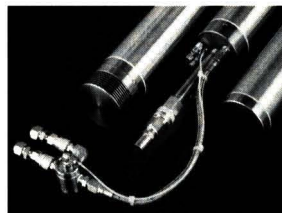

**Longyear**

2175 West Park Court • P.O. Box 1959  
Stone Mountain, GA 30086 USA  
(404) 469-2720 • Fax (404) 498-2841  
800-241-9468

Circle 73 on card.

**It Gets Lousy Gas Mileage.**



**Then Again, It Travels 300 Ft.  
Underground.**

VERTEK has revolutionized underground site characterization with our new line of cone penetrometer vehicles and sensors. Our CPT systems provide immediate graphical representation of in situ characteristics.

**REAL TIME ANALYSIS  
UNPRECEDENTED DETAIL  
COST EFFECTIVE**

- \* soil type, stratigraphy, permeability
- \* resistivity, temperature, radiation, pH
- \* soil, gas, and water sampling
- \* rapid installation of monitoring wells

What's more, with heavy push capacities to 40 tons, VERTEK CPT systems offer a faster, minimally invasive alternative to drilling to depths of 300 ft.

For detailed info, call  
**1(800) 639-6315**

**VERTEK**

a division of  
**APPLIED  
RESEARCH  
/ RUTOCHEM, INC.**

Circle 102 on card.

**GROUNDWATER, SOIL & VAPOR REMEDIATION PACKAGES TO YOUR DESIGN SPECIFICATIONS SKID OR TRAILER MOUNTED OR CONTAINER**

**YOU DON'T HAVE TIME TO WASTE!!**  
 WE'LL SIZE UP THE EQUIPMENT, MAKE IT COMPATIBLE, BUILD IT, PRETEST IT AND THEN SHIP IT!!!  
**INSTANT QUOTES INSTANT QUOTES**

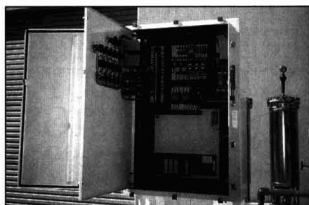
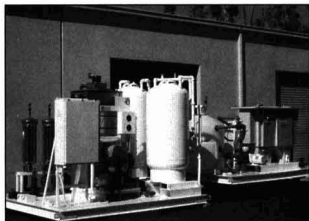

PRETESTED WITH IN-HOUSE SITE SPECIFIED SIMULATORS.

GROUNDWATER PUMPS, VAPOR EXTRACTION, INSTRUMENTATION SPECIALIZING IN CUSTOM CONTROLLERS TRAILER MOUNTED SYS. TURN-KEY REMEDIATION REMOTE LOCATION SYS. EMERGENCY RESPONSE SYSTEM

TREATMENT  
 ACTIVATED CARBON, AIR STRIPPING, BIOREMEDIATION/BIOVENTING, INJECTION/EXTRACTION, THERMAL/CATALYTIC OXIDATION, ELECTRIC OXIDATION



PROVIDING THE BEST IN ENVIRONMENTAL & GROUNDWATER

SYSTEMS AND EQUIPMENT  
 CALL (714) 587-1411  
 FAX (714) 587-9111

SERVICING

ENVIRONMENTAL CONSULTANTS -  
 MAJOR OIL CO., GOVERNMENT FACILITIES -  
 PROPERTY OWNERS MAJOR MANUFACTURING CO.

production and importation of methyl bromide at 1991 levels, and halted at the end of 2001. Use will be phased out after that date.

Some areas of scientific uncertainty exist in the technical assessments driving these moves. In calculating the global inventory of methyl bromide, it is assumed that all the chemical used in soil treatment and fumigation activities is lost to the atmosphere, eventually ending up in the stratosphere.<sup>11</sup> This assumption may not be supported by hypothesized mechanisms of removal before loss to the atmosphere.

In addition, recent work shows that the known biogenic emissions of methyl bromide from marine algae, giant kelp and volcanoes are substantially augmented by biomass combustion, accounting for as much as 30 percent of the stratospheric bromine budget.<sup>12</sup> There is great uncertainty in the global inventory of methyl bromide, with estimates ranging by as much as 60 percent to 70 percent. The role of various sinks in the atmospheric lifetime of methyl bromide also is unknown.

**Methyl Bromide Substitutes**

The economic impact of a ban on methyl

bromide is serious, estimated at \$1.3 billions to \$1.5 billion.<sup>13</sup> Substitutes to methyl bromide involve physical, chemical and biological alternatives. However, none has been identified yet that is not without major drawbacks. Many alternative chemical agents have already been banned in major markets, leaving methyl bromide as the last resort.

Physical methods such as irradiation and controlled atmospheres are either ineffective or suffer from poor public acceptance. Biological alternatives are attractive, but require many years of development.

The common obstacle of all alternatives is that no single method has been demonstrated to provide the high levels of pest mortality required for treatment and for quarantine.<sup>14</sup> Additional research will be needed in the coming years to develop these alternatives and to protect a vital portion of the nation's economy.

The controversy surrounding methyl bromide is a microcosm of the environmental issues with which the technical community is grappling. The technical issues are surmountable, but must be approached with a view to solve all facets of the problem.

**DELTA VANGUARD® AIR STRIPPERS REMOVE VOCs FROM GROUNDWATER**

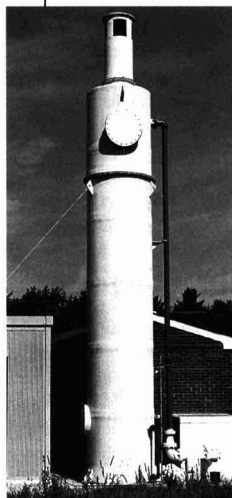

Delta Vanguard® Air Strippers purify groundwater by effectively removing fuel/gasoline hydrocarbons, chlorinated hydrocarbons, solvents, and certain other volatile organic chemicals (VOCs). Pre-piped and pre-wired skid mounted systems are available for economical low cost installation. Pre-assembled systems are also factory tested for trouble free start-up. Iron removal, chemical cleaning, air emission and other factory assembled and tested equipment packages, as well as pilot test units, are also available.

Delta-Pak® structured packing is an ultra low pressure drop mass-transfer media which efficiently removes most common contaminants, including some considered difficult, if not impossible, to strip while providing maximum resistance to fouling. Various other types of packings, as well as different column materials of construction, are also available.

**DELTA COOLING TOWERS, Inc.**

114 Clinton Road  
 Fairfield, N.J. 07004-2970  
 (201) 227-0300  
 Outside NJ 1-800-BUY DELTA  
 FAX (201) 227-0458

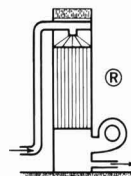

AD2



## **Powder Coating Will Give You Blues, Reds, Yellows... And, Most Importantly, A Lot More Green.**

That's because powder coating may represent the lowest cost of any finishing process on the market today. Powder coating is a completely dry process, eliminating runs, drips, and sags which result in a lower finished part reject rate. Parts can be racked closer together on a conveyor and therefore finished faster than with other finishing systems.

Because powder coating is a virtually pollution-free process and oversprayed powder can be recycled, costly anti-pollution and waste disposal equipment are unnecessary.

In all, powder coating results in greater operating efficiency, lower unit cost, and an overall superior finish. To find out more about powder coating, call The Powder Coating Institute at **1-800-988-COAT**.



THE  
POWDER COATING  
INSTITUTE

Circle 74 on card.

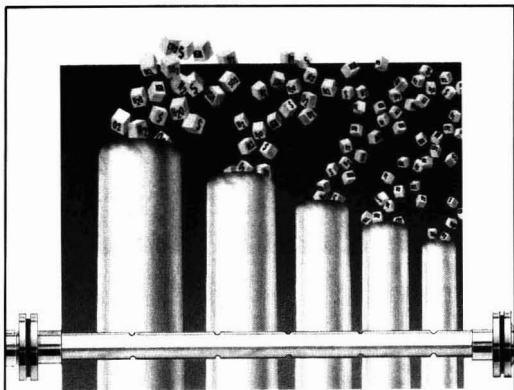

## Control Emissions.

### **ANNUBAR**

#### **MASS FLOW MONITORING SYSTEMS**

The new Annubar® Mass Flow Monitoring System, featuring the DSF-46 Annubar and Dart™ II Flow Computer, is the low cost, reliable way to measure mass flow accurately. Annubar is the solution. Dieterich Standard, P.O. Box 9000, Boulder, CO 80301 (303) 530-9600 • FAX: (303) 530-7064



**Dieterich Standard**

A DÜWEL Industries Company

Circle 75 on card.

## Pesticides

### References

1. Cicernone, R.J., "Fires, Atmospheric Chemistry and the Ozone Layer," *Science*, 263, 1243 (1994).
2. NIOSH Pocket Guide To Chemical Hazardous, June 1990, p. 146.
3. Nelson, L., Memorandum to Jim Wells, "Methyl Bromide Preliminary Risk Characterization," Department of Pesticide Regulations, Feb. 11, 1992.
4. Radian Corp. report submitted to California Department of Pesticide Regulation (CDPR), Oct. 26, 1992.
5. California Department of Pesticide Regulations, Draft Permit Conditions, April 1993.
6. Segawa, Randy, CDPR Memorandum, "Results of Off-Site Air Monitoring Following Methyl Bromide Chamber Fumigations and Evaluation of the ISCST Model," Sept. 3, 1992.
7. Cicernone, R.J., "Fires, Atmospheric Chemistry and the Ozone Layer," *Science*, 263, 1243 (1994).
8. Anderson, J.G., D.W. Toohey, W.H. Brune, *Science*, 251, 39 (1991).
9. "Methyl Bromide: Its Atmospheric Science Technology and Economics," United Nations Environment Programme, Nairobi, Kenya, 1992.
10. Van der Leum, J.C., M. Tevini, "Environmental Effects of Ozone Depletion, 1991 Update," 263, 1255 (1994). UN Environment Programme, Nov. 1991.
11. Cicernone, R.J., "Fires, Atmospheric Chemistry and the Ozone Layer," *Science*, 263, 1243 (1994).
12. Mano, S., M.O. Andrac, "Emission of Methyl Bromide from Biomass Burning," *Science*, 263, 1255 (1994).
13. National Agricultural Pesticide Impact Assessment Program, "The Biologic and Economic Assessment of Methyl Bromide," U.S. Department of Agriculture, April 1993, p. 2.
14. Civerolo, Edwin, S. Karl Narang, Ralph Ross, Kenneth Vick, eds., "Alternatives to Methyl Bromide: Assessment of Research Priorities," USDA, 1993.

### Milco Safety Rental

# We're equipped to please.

## Rental, Sales and Repair for Environmental and Industrial Safety Equipment

- No minimum rental charge for most instrumentation
- No calibration/set-up fee
- No rental fee for shipping day or return day if equipment is back before noon
- Daily, weekly and monthly rental rates applied to your best advantage
- Orders shipped on the same day they're received

**1-800-775-1738**



MILCO SAFETY RENTAL

Customer Comfortable

9033 W. Monroe • Houston, Texas 77061  
(713) 947-0050 Fax (713) 947-1738

Circle 76 on card.

# THE MISSION: TO SEARCH AND DEPLOY

My brief originates from a major European company in the business of supplying innovative and effective environmental technology to clients in the UK, Europe and Far East. If you are seeking representation for your technology please forward details for a prompt response to:

**Garry Howes**  
**Commercial Dexterity Limited**  
**Greenacre House**  
**Sorrel Close**  
**Wokingham, Berkshire RG11 5YA**  
**England**  
**Fax: +44 1734 780 028**

Circle 77 on card.

*continued from page 44*

These technologies are growing in application because of productivity and economics. They provide understandable information in greater quantities quickly and at less cost. They draw the user into the information dialogue by making it easy to navigate within large, complex and diverse information sets. They provide a responsiveness through which the environmental manager can relate to facility conditions and situations quickly and intuitively. Reports show that ESH management costs are approaching 4 percent of a corporation's sales, a formidable figure. Reducing these costs has become a goal in many companies, and improved productivity in the management of information is one way to address this objective.

The 1990s have followed the Macintosh model of the 1980s through the introduction of numerous GUI technologies (Windows-Chicago, 95, Daytona, NT, Cairo, OS/2, Motif, Openview and more). The faster chips are competing for the next generation of users. GIS has emerged with layer-based commercial software, and object-based systems are commercially challenging the installed base. Established corporations in the information industry are struggling and new corporations are emerging at spectacular growth rates. Alliances are forming among major hardware and software vendors.

Superimposed on the information revolution, a post-Cold War consolidation among defense industries is under way in the United States. Corporations within all industry sectors are developing international visions, broader outlooks and strategies for global competition.

As we move into the 21st century, object-based GIS with geo-GUI navigation will become a standard for information access. Spatial interaction with information (virtuality) will be used routinely to display existing and possible situations for planning and decision-making purposes. Global economic battles will be fought for survival in the information arena and in all other industry sectors.

Finally, users have to deal with the promise of this new information technology. It has a wealth of potential for adding efficiency to dealing with regulatory pressures and improving the environment. But it must be implemented prudently, for there also is the potential for information overload and a new set of problems and demands related to this technology. **EP**

## Coming In February: EP's Laboratory Focus

**Testing and Instrumentation:** In next month's issue, two articles focus on laboratory technology and service selection.

One summarizes some of the innovations in the laboratory, including particulate monitoring and new applications of laser technology.

Our other feature explains why low competitive bids may not mean the best buy in lab services. The author offers seven steps to an informed decision that avoids labs trying to work with low-quality instrumentation, no quality assurance/quality control program, inexperienced staff and poor customer service and support.



# GIVE TYMCO A CRACK AT YOUR STORMWATER FINES.

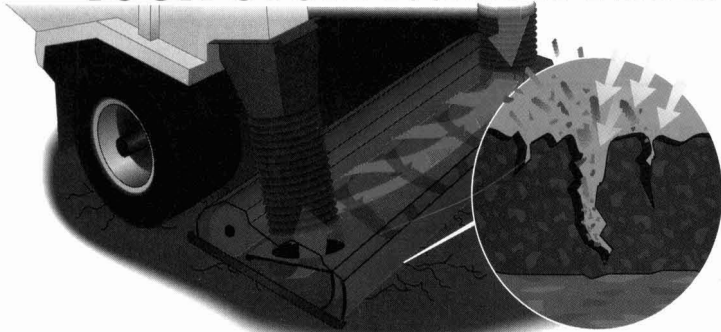

**TYMCO REGENERATIVE AIR SWEEPERS™** blast into pavement cracks with the force of a 250 mph controlled jet of air, forcing up even the finest particulates into a totally enclosed system —never exhausting dirty air as do vacuum sweepers.

**Your NPDES permit demands that stormwater pollution be reduced by the "Maximum Extent Practicable."** Because swept is not always clean, call Tymo. With twice the power of pure vacuum, Tymo captures even the micron-size particulates your broom left behind. All with only a few

moving parts — an incredible simplicity that reduces your maintenance, training and downtime. Tymo. We clean deeper.



### COMPLIMENTARY GUIDE

**"Writing Your Best Management Practice for Street Cleaning"**  
A generic, easy-to-use sample. Use your circle card or call **1-800-258-9626.**



Environmentally Superior Cleaning

All Work is Backed by Our Unmatched Guarantee:  
YOU MUST BE COMPLETELY SATISFIED,  
OR YOU PAY ABSOLUTELY NOTHING!

# Whatever Your Sludge Problem, We Have Low-Cost Solutions for You.

Complete Turnkey Services or  
Rent Our Equipment and  
Save by Doing the Work Yourself

- Mobile fleet of state-of-the-art, high volume sludge dewatering units.
- Fast response to emergencies.
- Quick delivery, set-up, breakdown & removal.
- Short, month-to-month, or long-term leasing.
- Operate with our personnel or yours - we can provide quick on-the-job training.
- No capital investment.

For a Free Job Site Survey and  
Cost Estimate call Toll-Free:

**1-800-621-4342**



Carylon Companies

#### **BIO-NOMIC SERVICES, INC.**

516 Roundtree Road, Charlotte, NC 28217-0237

#### **METROPOLITAN ENVIRONMENTAL SERVICES, INC.**

107 N. Mill Street, P.O. Box 322, Celina, OH 45822-0322

#### **MOBILE DREDGING & PUMPING CO.**

3100 Bethel Road, Chester, PA 19013-1405

#### **TRANSPORTATION TREATMENT SERVICES, INC.**

1461 Harbor Avenue, Long Beach, CA 90813-2741



### **SLUDGE REMOVAL**

#### We Can Cut Your Cost of Eliminating Sedimentation & Buildup...

We can handle virtually any type  
of clean-out: pits, ponds, lagoons, industrial  
tanks, digester, etc.

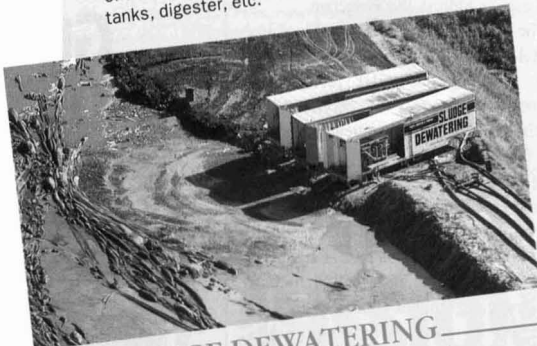

### **SLUDGE DEWATERING**

#### We Can Cut Your Disposal Costs...

Our transportable dewatering units come to you. Fast  
process reduces sludge to a small fraction of its original  
volume, producing cake-like material suitable for  
incineration, landfill or land application disposal. Sampling  
and monitoring insure environmental compliance.

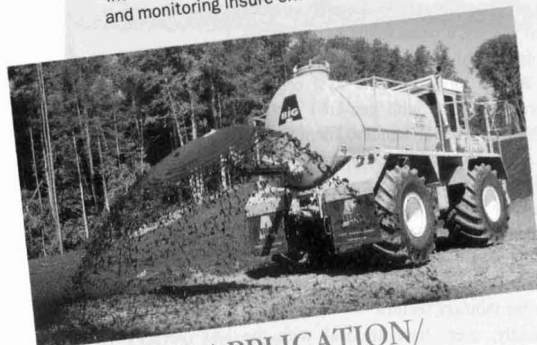

### **LAND APPLICATION/ BENEFICIAL USE**

#### We Can Get Rid of your Sludge.

with Full Environmental Approval  
Our sophisticated program will transport and land apply  
liquid, semi-solid or dry bio-solids on a large or small  
scale, with minimal soil compaction.

# Environmental PROTECTION

## 1995 Buyer's Guide

### Contents

Products and Services Index .....	68-69
Products and Services Directory .....	71-115
Major 1995 Meetings .....	116
Company Profiles Directory .....	117-135

## How To Use This Guide

### Products/Services

For quick and easy reference to a specific product or service, turn to page 68. This clearly marked section contains alphabetical listings of companies offering various products and services. For your convenience, the listings are divided into detailed categories. You can find additional information by cross-referencing supplier names to the Company Profiles Section of the *Buyer's Guide*.

### Company Profiles

To find details about a specific company, turn to page 117. This alphabetical reference section is a valuable resource for readers needing to find listings of companies that sell products and services in the environmental market. Each Company Profile contains in-depth information, including company name, address, phone number and products/services (advertisers only). *Buyer's Guide* advertisers' ad page numbers are listed in bold type under the Company Profile listing.

### Major Meetings

For information on important conferences in 1995, turn to page 116. This section contains a calendar of major trade shows.

# Products and Services

This section of the 1995 Environmental Protection *Buyers Guide* alphabetically lists companies that market products and services. For more information, cross-reference the supplier in the company profiles section, beginning on page 146. Also, *Buyer's Guide* advertisers' ads are listed in bold type with the page numbers of their advertisements.

<b>A</b>	<b>PAGE</b>		
Aboveground Storage Tanks	71	Carbon Adsorption	76
Absorption Equipment	71	Carbon Dioxide Detectors	76
Accumulators	71	Carbon Monoxide Detectors	76
Acid Rain Gauge	71	Carbon Reactivation	76
Acoustical Chambers	71	Carbon Regeneration Systems	76
Activated Carbon	71	Cascade Impactors	76
Actuators	71	Catalysts	76
Adsorbent Equipment	71	Cathodic Protection Equipment	76
Aeration Systems	71	Centrifuges	76
Aerators/Diffusers	71	Chemical Information	76
Aerosol Detectors	71	Chemical Odor Control	76
Aerosol/Particle/Smoke Generators	71	Chemical Storage Buildings	76
Agglomerators/Briquetters/Pelletizers	71	Chemicals	76
Agitators	71	Chillers	76
Air Analyzers	71	Chlorination Equipment	77
Air Classifiers	71	Chlorine Detectors	77
Air Curtains	71	Chromatographs	77
Air Emission Monitoring Equipment	71	Clamps, Pipe	77
Air Emissions Testing	72	Clarifiers	77
Air Exhaust Noise Control	72	Clarifiers Drive Units	77
Air Filters	72	Clean Rooms/Supplies	77
Air Make-up Units	72	Cleaning Equipment/Supplies	77
Air Quality Instrumentation	72	Cleaning/Flushing Services	77
Air Pollution Control Equipment	72	Clothing, Protective	77
Air Samplers	72	Coagulation	77
Air Strippers	73	Coatings/Linings	77
Air Velocity Meter	73	COD Instrumentation	77
Alternative Energy Process	73	Colorimeters	77
Anaerobic Pretreatment	73	Combustible Gas Detectors	77
Analysis, Atomic Absorption	73	Combustion Control Instruments	77
Analysis, Electron Microscopy	73	Communication Equipment	77
Analysis, Gas Chromatography	73	Communitors/Grinders	77
Analysis, Gas Chromatography/Mass Spectrometry	73	Compactors	78
Analysis, Liquid Chromatography	73	Composting Systems	78
Analysis, Soil, Water, Air	73	Compressors	78
Analytical Instruments, Air	74	Computer Control	78
Analytical Instruments, Hazardous Materials	74	Computer Databases	78
Analytical Instruments, Rentals	74	Computer Devices	78
Analytical Instruments, Wastewater	74	Computer Modeling (Air, Groundwater, Hazard & Risk)	78
Analytical Instruments, Water	74	Computer Software, Chemical Database	78
Analytical/Research Services	74	Computer Software, Management	78
Annunciators/Alarms	74	Computer Software, Management (MSDS)	78
Aquifer Restoration	74	Computer Software, Regulatory	78
Asbestos Abatement Services/Equipment	74	Computer Software, SARA Reporting	79
		Computer Software, Training	79
<b>B</b>	<b>PAGE</b>	Concentrators	79
Backflow Preventers	75	Conductivity Instrumentation	79
Bacteria/Enzymes	75	Consulting Services	79
Bacteriological Supplies	75	Contracting Services	79
Baffles/Booms	75	Controllers	79
Baghouse Monitoring	75	Conveyors	80
Baghouses	75	Cooling Tower Water	80
Balances	75	Cooling Towers	80
Balers	75	Core Sampler	80
Barriers	75	Corrosion Instrumentation/Protection	80
Batching/Blending Systems	75	Couplings	80
Bentonite	75	Covers/Domes	80
Bin Discharger	75	Crushers	80
Bin/Hoppers	75	Cyclones	80
Bioassay	75		
Biological Testing Apparatus/Supplies	75	<b>D</b>	<b>PAGE</b>
Biomass Combustion	75	Dampers	80
Bioremediation	75	Data Acquisition Equipment	80
Bird Control	75	Data Loggers	80
Blowers	75	Deaerators/Degasifiers	80
Blowers - Corrosion, Resistant	75	Dechlorination Equipment	80
Blowers - SVE and GWS	75	Decontamination Equipment	80
BOD Test Equipment	75	Deep Well Systems	81
Boiler Feedwater Treatment Equipment	75	Defoaming/Degreasing Equipment	81
Boilers	75	Dehumidifiers	81
Burners	75	Deionizers	81
Bushings	76	Demineralizers	81
		Density Instrumentation	81
<b>C</b>	<b>PAGE</b>	Desalination Equipment	81
Calibration	76	Detectors	81
Calorimeters	76	Diffusers	81
		Digesters	81
		Directories	81
		Disinfection Equipment, Water	81
		Dissolved Oxygen Detectors	81
		Dissolved Solids Detectors	81
		Distillation Equipment	81
		Dredges	81
		Dredging Services	81
		Drilling, Water	81
		Drum Deheader	81
		Drum Pumps	81
		Drums	81
		Drying Equipment	81
		Ducts/Stacks/Chimneys	82
		Dust Collector Accessories/Supplies	82
		Dust Collector Controls	82
		Dust Suppression Systems	82
		<b>E</b>	<b>PAGE</b>
		Electrostatic Precipitator	82
		Electrostatic Precipitator Supplies/Accessories	82
		Elevators	82
		Emergency Response Training Services	82
		Employment Services	82
		Enclosures, Instrument/Valve	82
		Enclosures, Structural	82
		Engine Test Equipment	82
		Engineering Services	82
		Engines	82
		Environmental Audits	82
		Environmental Engineering	83
		Environmental Site Assessment	83
		Environmental Test Chambers	83
		Equipment Rental	83
		Evaporation Equipment	84
		Excavating Service	84
		Expansion Joints	84
		Explosion Vents	84
		<b>F</b>	<b>PAGE</b>
		Fabric Filter	84
		Fabricated Metal Products	84
		Fan Repair/Rebuilding	84
		Feeders	84
		Feedwater Treatment Equipment	84
		Fiberglass Products	84
		Field Testing Instruments/Services	84
		Filter Accessories	84
		Filter Presses	84
		Filtration Systems	84
		Fire Safety Equipment	85
		Fittings	85
		Flame Arrestors	85
		Flash Point Tester	85
		Floating Baffles	85
		Floats/Portoons	85
		Flocculants	85
		Flotation Equipment	85
		Flow Instrumentation	85
		Flowmeters, Mass	85
		Flowmeters, Variable Area	85
		Flue Gas Conditioning	85
		Flue Gas Desulfurization	85
		Flumes/Weirs	85
		Flushing/Cleaning Equipment	85
		Fly Ash Recovery/Treatment Systems	85
		Freeze Protection	86
		Fume Exhaust System	86
		Fume Hoods	86
		<b>G</b>	<b>PAGE</b>
		Gas Chromatographs	86
		Gas Cooling Equipment	86
		Gas Detectors	86
		Gas Source/Supplies	86
		Gas Storage Equipment	86
		Gaskets/Packing/Seals	86
		Generators	86



Geographic Information Systems	86	Odor Control Treatment	94	Sludge Management	103
Geophysical Instruments	86	Oil Skimmers	94	Sludge Solidification	103
Geotextiles	86	Oil Spill Control Equipment/Services	94	Slurry Cut-off Walls	103
Glassware	86	Oil/Water Monitors	95	Soil Gas/Groundwater Surveys	103
Groundwater Reclamation	86	Oil/Water Separation	95	Soil Sampling Equipment	106
Groundwater Testing & Monitoring Equipment	86	Opacity	95	Solvent Recovery Systems	106
Groundwater Treatment/Services	87	Operation & Maintenance Services	95	Sonic Cleaning Devices	106
<b>H</b>	<b>PAGE</b>	ORP Instrumentation	95	Speed Reducers	106
Hazardous Material Handling	87	Oxidizers	95	Spill Control Equipment/Products/Services	106
Hazardous Material/Waste	87	Oxygen Detectors	95	Spraying Equipment	106
Hazardous Waste Containers	88	Ozonators	95	Stack Emission Monitors	106
Hazardous Waste Equipment	88	Ozone Detectors	95	Stack Emission Testing	106
Hazardous Waste Handling	88	<b>P</b>	<b>PAGE</b>	Stack Flow Meters	107
Hazardous Waste/Mat Treatment, Storage, Disposal	88	Packaged Treatment Plants	95	Standards	107
Hazardous Waste Recycling	88	Packing Materials	96	Sterilizers	107
Hazardous Waste Services	88	Particle Detectors	96	Stormwater Monitoring	107
Hazardous Waste Transportation	89	Particle Sizing Instruments	96	Stormwater Treatment	107
Heat Exchangers	89	Passive Hydrocarbon Recovery System	96	Strainers	107
Heat Recovery Systems	89	PCB Replacement	96	Subcontractors	107
Heating Cable/Tape	89	PCB Testing	96	Sulfate/Sulfide Detectors	107
Heavy Metal Detectors	89	Permitting	96	Sulfur Dioxide	107
Hose/Tubing	89	Pest/Weed Control	96	Sulfur Oxide Detectors	107
Humidity Instrumentation	89	pH Instrumentation	96	Suspended Solids Instrumentation	107
Hydrocarbon Detectors	89	Pipeline Cleaning, Repair	96	Sweepers, Air Sweepers	107
Hydrogen Sulfide Control	89	Piping, Dual Containment	96	Sweepers, In Plant Sweepers	107
Hydrogen Sulfide Detectors	89	Piping Equipment	96	Sweepers, Truck Mounted - In Plant	107
Hydrological Equipment	89	Pollution Survey Equipment	96	<b>T</b>	<b>PAGE</b>
<b>I</b>	<b>PAGE</b>	Polymer Blending/Feeding Systems	96	Tanks	107
Identification Systems	89	Portable Computers	96	TCLP	108
Incineration Systems	89	Pressure Boosters	96	Telemetry Systems	108
Indoor Air Quality	90	Pressure/Vacuum Instrumentation	96	Telescoping Valves	108
Industrial Hygiene	90	Process Control Instrumentation	97	Temperature Instrumentation	108
Inline Mixers	90	Professional & Trade Associations	97	Test Equipment, misc.	108
Instrument Rental	90	Programmable Controllers/Timers	97	Test Kits/Services	108
Insulation, Thermal	90	Protective Clothing	97	Tire Combustion Equipment	108
Insurance	90	Pulverizers	97	Thermal Oxidizers	108
Intake Screens	90	Pump Controllers	97	TOC Detectors	108
Intercoms	90	Pumping Stations/Systems	97	Tools	108
Ion Exchange	90	Pumps (sludge, wastewater, groundwater)	97	Total Carbon Detectors	108
<b>L</b>	<b>PAGE</b>	<b>R</b>	<b>PAGE</b>	Total Nitrogen Analyzers	108
Labeling	90	Radiometer/Radiation Instrumentation	97	Total Oxygen Demand	108
Laboratory Equipment/Supplies	90	Radon, Testing & Analysis	97	Total Sulfur Detectors	108
Laboratory Services/Testing	91	Recorder Accessories	97	Toxic Gas Detectors	108
Lagoon Separators/Baffles	91	Recorders	97	Toxicological Services	108
Land Application Equipment	91	Recycling Equipment/Services	98	Tracer Products	108
Land Application Systems	91	Reference Material	98	Training Services/Equipment	108
Landfills	91	Reflectometers	98	Training Videos	110
Landfill Equipment	91	Refractometers	98	Transmitters	110
Landfill Services	91	Refractory Materials	98	Transportation	110
Leachate Treatment	91	Regulators	98	Traps	110
Lead Paint Abatement	91	Remediation	98	Trucks/Trailers	110
Leak Detectors	92	Remediation, Insitu	98	Turbidity Instrumentation	110
Level Instrumentation	92	Remediation Services	98	Turbidity Standards	110
Level, Sight Gauges	92	Rental Services	99	<b>U</b>	<b>PAGE</b>
Lift Stations	92	Research Services	99	Ultrafiltration Equipment	110
Lime Slakers	92	Respirometers	99	Underground Storage Tank Equipment	110
Liners	92	Reverse Osmosis Equipment	99	Underground Tank Leak Monitors	110
Liquid Extractors	92	Risk Analysis	99	<b>V</b>	<b>PAGE</b>
Locators, Pipe/Valve/Cable	92	Rupture Disks	99	Vacuum Cleaning Equipment	110
<b>M</b>	<b>PAGE</b>	<b>S</b>	<b>PAGE</b>	Vacuum Loading Equipment	110
Make-up Air System	92	Safety Equipment & Products	99	Vacuum, Critical Filter	110
Management Services	92	Sample Containers	99	Valve Actuators/Operators	110
Manometers	92	Sampling Systems	99	Valve Positioners	110
Medical Waste Disposal	92	Screens	99	Valve Replacement Parts	111
Mercury Instruments	92	Scrubbers	99	Valve Systems	111
Mercury Spill Cleanup Products	92	Sealants	102	Valves	111
Metal Recovery Systems	92	Secondary Containment	102	Vapor Recovery	111
Meteorological	92	Sedimentation Equipment	102	Variable Speed Drives	111
Meters	92	Sensors	102	Ventilation Equipment	111
Mist Eliminators/Collectors	93	Separation Systems	102	Vents	111
Mixers	94	Separators	102	Vibration Instruments	111
Mobile Labs	93	Septic Tanks	102	Viscosity Instruments	111
Moisture Instrumentation	93	Sequencing Batch Reactors	102	VOC Removal Systems	111
Monitoring Systems, Air	93	Settling Chambers	102	<b>W</b>	<b>PAGE</b>
Monitoring Systems, Hazardous Material	93	Sewage/Sludge Disposal Equipment/Services	102	Waste Energy	111
Monitoring Systems, Water	93	Sewage Transport Systems	102	Waste Minimization	111
Motor Controllers	94	Sewerage Systems, Vacuum	102	Wastewater Treatment Systems	114
Motors	94	Sewer Inspection TV System	102	Water Conditioning Equipment	114
<b>N</b>	<b>PAGE</b>	Shelters	102	Water Jetting Equipment	114
Nitrogen Oxide Detectors	94	Shredders	103	Water Meters	114
Noise Deadening Supplies	94	Signal Conditioners	103	Water Purification Systems	114
Noise/Sound Instruments	94	Silencers/Mufflers	103	Water Quality Instrumentation	114
Nozzles	94	Site Assessment	103	Water/Wastewater Treatment Equipment	115
Nuclear Waste Handling Equipment	94	Sludge Blanket Level	103	Water/Wastewater Treatment Plants	115
<b>O</b>	<b>PAGE</b>	Sludge Concentrating Equipment	103	Weather Monitoring	115
Oceanographic Equipment	94	Sludge Dewatering/Disposal Service	103	Wetlands	115
Odor Control Equipment	94	Sludge Dewatering Equipment	103		

# Safety Storage™ Buildings, Lockers, Sumps, and Pallets



*Safety Storage™ hazmat buildings provide regulatory compliance with maximum flexibility!*

Safety Storage prefabricated, weatherproof hazmat storage buildings provide a low cost solution to remove chemical hazards from your facility, to safeguard personnel, provide secondary containment for soil and groundwater protection, minimize your liability, and meet fire safety needs, while complying with federal, state and local regulations.

Safety Storage, the nation's leading manufacturer of prefabricated chemical and hazardous materials storage buildings, offers over 140 standard models plus a host of options to meet specific user requirements.



## 4-HOUR FIRE-RATED BUILDINGS

4-Hour Series fire-rated buildings meet environmental and safety requirements for storage and dispensing of flammable

and combustible materials. These heavy duty, relocatable buildings meet or exceed requirements for UL 4-hour rating classification. Standard features include spill containment sump, corrosion-resistant fiberglass floor grating, security locks, and grounding system. Full range of options. Buildings available with up to 176 sq. ft. of floor space.

**Circle 6 on card.**

## 2-HOUR FIRESHIELD FIRE-RATED BUILDINGS

The Fire Shield FS Series is the first all-welded, unitized 2-hour fire-rated building line in the industry.

These heavy duty, relocatable buildings meet or exceed federal and state regulatory requirements for UL 2-hour rating classification. FS Series buildings incorporate all of the standard features and options of the 4-Hour Series and are available with up to 320 sq. ft. of floor space.

**Circle 8 on card.**

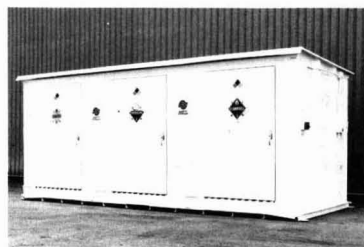

## NON-COMBUSTIBLE STEEL BUILDINGS AND LOCKERS

Heavy duty, welded steel buildings and lockers feature secondary containment

sump, corrosion-resistant floor gratings, security locks, fire sprinklers, and grounding system. Options include dry chemical fire suppression, explosion proof lighting, heating, air conditioning, and forced air ventilation. Buildings and lockers available with up to 348 sq. ft. of floor space.

**Circle 5 on card.**

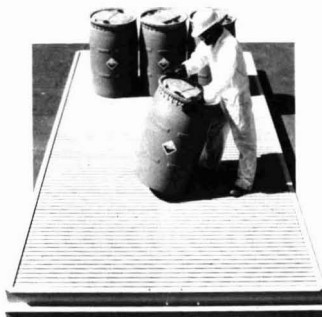

## PORTABLE SPILL CONTAINMENT SUMPS AND PALLETS

Sumps available in five standard sizes with up to 320 sq. ft. of floor space. Largest model holds up to eighty 55-gallon drums and has a 1,340-gallon spill containment sump capacity. Strong, durable fiberglass

floor grating standard. Custom sizes available. Compact polyethylene or steel Safe-T-Pallets hold four 55-gallon drums and have a sump capacity of 90 gallons.

**Circle 7 on card.**

## SPECIAL APPLICATIONS

Safety Storage special application buildings can be customized for specific uses such as solvent recovery, chemical mixing, portable laboratory, and other dedicated activities.

## SPECIFY SAFETY STORAGE WITH CONFIDENCE

Safety Storage was the first and continues to be the leader in prefabricated hazmat storage buildings, including turnkey installations. We're approved for use by more jurisdictions throughout the nation, we have more third party approvals, and have the most complete warranty in the industry.

## FREE HAZARDOUS MATERIAL STORAGE SURVEY

Call us today for a free, no-obligation survey of your hazardous materials storage requirements by factory trained field professionals. Ask us about our video, explaining our products in depth.

**Circle 9 on card.**

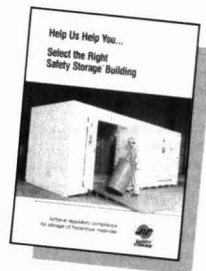

**Call Toll Free: 1-800-344-6539**



**SAFETY STORAGE™**

*...professional hazmat solutions!*

SAFETY STORAGE, INC.  
2301 Bert Drive  
Hollister, CA 95023  
Phone: 408-637-5955  
Fax: 408-637-7405

## Aboveground Storage Tanks

A O Smith Harvestore Products Inc  
ARD Environmental Inc  
ATI  
Aero-Power Utilized Fueler Inc  
Atlantic Screen & Mfg Inc  
Atlantic Testing Laboratories Limited  
BEM Systems Inc  
Bacharach Inc  
Brown Minneapolis Tank  
CMI-Schneible Co

**CHEM-TAINER**  
INDUSTRIES, INC.  
1-800-275-2436

Chem-Tainer Industries  
Conspan Bridge Systems  
Conwall Inc

SEE AD ON PAGE 140

Denver Mineral Engineers Inc  
Direct Safety Co  
EA Engineering, Science  
& Technology Inc  
EPG Companies Inc  
Environetics Inc  
Environmental Products & Services Inc  
Envirovision Group Inc, The  
Ferrick Construction Co Inc  
Fluid Controls Inc  
Forrer Supply Co Inc  
Foster Wheeler Environmental Corp  
Gurman Container & Supply Corp  
Highland Tank  
Hill International Inc  
Kinane Engineering  
Nalge Co  
Ogden Environmental & Energy Services  
Parsons Engineering Science Inc  
Plastic Fusion Fabricators  
R E Wright Associates Inc (REW)  
Serrot Corp  
Smith & Loveless Inc  
Steel Tank Association  
Superior Environmental Corp  
Tank Industry Consultants Inc  
United States Filter Corp  
Vibra Screw Inc

## Absorption Equipment

Advanced Industrial Technology Corp  
American Environmental International Inc  
Anderson 2000 Inc  
Barnebey & Sutcliffe Corp  
Ben Meadows  
CMI-Schneible Co  
Croll Reynolds Co Inc  
Direct Safety Co  
Durr Industries Inc  
Environmental Industrial Resources  
Environmental Products & Services Inc  
General Carbon Corp  
Green Earth Technologies Corp  
Hazco Services Inc  
Lab Safety Supply  
MSA

Met-Pro Corp Systems Div  
SEE AD ON PAGE 43  
Morian & Norian Inc  
Norton Chemical Process Products Corp  
ORS Environmental Systems  
Remedial Systems Inc  
Wheelabrator Environmental  
Systems Inc  
Wolfto Group Inc

## Accumulators

Cole-Parmer Instrument Co  
Durr Industries Inc

## Acid Rain Gauge

Climatronics Corp

## Acoustical Chambers

BRD Noise & Vibration Control Inc  
Engelhard Corp  
United McGill Corp

## Activated Carbon

Activated Carbon Resources  
Activated Carbon Technology  
Barnebey & Sutcliffe Corp  
Biomin Inc  
Calgon Carbon Corp  
Cameron-Yakima Inc  
Carbon Activated  
Carbon Service & Equipment Co  
Carbonchem Inc  
Carbrol Corp  
Disclo Corp  
Diversified Well Products Inc  
SEE AD ON PAGE 30  
Ducon Environmental Systems Inc

**DURR**

313-459-6800

Durr Industries Inc  
EPG Companies Inc  
Environmental Products & Services Inc  
Environmental Protection Systems  
General Carbon Corp  
GeoPure Continental Systems & Services  
H2 Oil Recovery Equipment Inc  
Micro Air, Air Cleaners by Metal-Fab Inc  
Misonix Inc  
National Environmental Systems Inc  
Nort Americas Inc  
Northwestern Carbon  
Osmonics Inc

SEE AD ON PAGE 31

Professional Analytical & Consulting  
Services Inc  
Sertifiko Ltd  
Smith & Loveless Inc  
Spectrum Chemical & Safety Products  
Vara Intl Div of Calgon Carbon Corp  
Water Equipment Tech  
Western Filter Co  
Wheelabrator Environmental  
Systems Inc  
Zimpro Environmental Inc

## Actuators

Asahi/America Inc  
Boston Gear  
Chemtrol Div of Nibco Inc  
Duriron Co Inc, The  
George Fischer Inc  
Limitrque  
Parker Hannifin Corp  
SEE AD ON PAGE 144  
Progressive Equipment Corp  
Rosemount Analytical Inc  
Rotork Controls Inc  
Soltec Corp  
Xomox Corp

## Adsorbent Equipment

Calgon Carbon Corp  
Carbon Service & Equipment Co  
Denver Mineral Engineers Inc  
Dival Safety Equipment  
Dual Div Met-Pro Corp  
Ducon Environmental Systems Inc  
Durr Industries Inc  
Environmental Fuel Systems Inc  
Environmental Products & Services Inc  
General Carbon Corp  
Hazco Services Inc  
New Pig Corp  
SEE AD ON PAGE 138  
Northwestern Carbon  
Professional Analytical & Consulting  
Services Inc  
Purus Inc

Remco Engineering  
Remedial Systems Inc  
Silkwick Sorbents  
Spectrum Chemical & Safety Products  
Wheelabrator Environmental  
Systems Inc  
Wolfto Group Inc

## Aeration Systems

Aeromix Systems Inc  
Aqua Tech Industries Inc  
AquaTec Inc  
CET Environmental Services Inc  
Carbrol Corp  
EPG Companies Inc  
Envirex  
Environmental Restoration  
Systems Inc  
SEE AD ON PAGE 18

Fluidyne Corp  
Framco Environmental Technologies  
H2 Oil Recovery Equipment Inc  
Hazleton Environmental  
Hydro Group  
Inn-Nova-Tech Inc  
Lakeside Equipment Corp  
Lamson Corp  
Mastrri Co, The  
National Environmental Systems Inc  
North East Environmental Products Inc  
Parkson Corp  
Pollution Control Inc  
Purestream Inc  
R E Wright Associates Inc (REW)  
RGF Environmental Systems Inc  
Remco Engineering  
Remedial Systems Inc  
Schreiber Corp Inc  
Smith & Loveless Inc  
Triology Controls Inc  
Water Inc  
Wheelabrator Environmental  
Systems Inc  
Zimpro Environmental Inc

## Aerators/Diffusers

Aeromix Systems Inc  
AquaTec Inc  
Carbrol Corp  
Chemineer Inc  
EIMCO Process Equipment Co  
Envirex  
Ferro Corp, Specialty Ceramics Div/Filtros  
Plant  
Filtros Plant, Ferro Corp  
Fluidyne Corp  
Framco Environmental Technologies  
GeoPure Continental Systems & Services  
Hazleton Environmental  
Hydro Group  
Inn-Nova-Tech Inc  
Jet Inc  
Lamson Corp  
Mastrri Co, The  
National Environmental Systems Inc  
Parkson Corp  
Plastic Fusion Fabricators  
Pollution Control Inc  
Purestream Inc  
Schreiber Corp Inc  
Smith & Loveless Inc  
Water Inc  
Zimpro Environmental Inc

## Aerosol Detectors

HI-Q Environmental Products Co  
SEE AD ON PAGE 47  
TSI Inc/Environmental Measurements &  
Controls Div  
Wheelabrator Environmental  
Systems Inc

## Aerosol/Particle/Smoke Generators

Wheelabrator Environmental  
Systems Inc

## Agglomerators/Briquettes/Pelletizers

APV Heat Transfer/Separation  
Technologies  
Hazco Services Inc  
Universal Process Equipment Inc

## Agitators

Associated Design & Mfg  
Chemineer Inc  
Fluidyne Corp  
Glen Mills Inc  
Liquid Waste Technology Inc  
SEE AD ON PAGE 35  
Neptune Chemical Pump Co  
Smith & Loveless Inc  
Universal Process Equipment Inc  
Zimmerman Industries Inc

## Air Analyzers

A I W Inc  
Accredited Laboratories Inc  
Air Instruments & Measurements Inc  
Anarad Inc  
Ariel Industries Inc  
Arizona Instrument Corp  
Bacharach Inc  
Bascom-Turner Instruments  
Ben Meadows  
Bruel & Kjaer Instruments  
CEA Instruments  
California Analytical Instruments Inc  
Clean Air Engineering  
Climatronics Corp  
Columbia Science Industries Co  
Columbia Scientific  
Control Instruments Corp  
Dasibi Environmental Corp  
Dival Safety Equipment  
ENMET Corp  
Energy Efficiency Systems Inc  
SEE AD ON PAGE 11  
Engelhard Corp  
Entech Instruments Inc  
Environmental Monitor Systems Inc  
Environmental Technologies Group  
Envioplan Inc  
Foxboro Co, The  
SEE AD ON PAGE 46

**GA TECH**  
510-745-1275

Gas Tech Inc  
General Analysis Corp  
Hazco Services Inc  
Horiba Instruments Inc  
SEE AD ON PAGE 44

Intek Corp/Rent-Alyzer  
International Sensor Technology  
Keeco R & D Inc  
LINC Quantum Analytics  
Lab Safety Supply  
MKS Instruments Inc  
MSA  
McNeill International  
Metrosonics Inc  
Midwesco Filter Resources Inc  
Monitor Labs Inc  
NovaLynx Corp  
OI Analytical  
Omega Engineering Inc  
SEE AD ON PAGE 2  
Oxford Environmental Inc  
PACE Environmental Products  
PDG Environmental Inc

Photovac Monitoring Instruments  
SEE AD ON PAGE 42

Response Rentals  
Sensidyne Inc  
Sentex Systems Inc  
Servomex Co Inc  
Siemens Industrial Automation Inc  
Sierra Monitor Corp  
Solomat  
Stanley Consultants Environmental Inc  
Thermo Environmental Instruments  
Wheelabrator Environmental  
Systems Inc

## Air Classifiers

ABB Paymond  
Climatronics Corp  
Engelhard Corp  
G E Co  
General Kinematics Corp  
Universal Process Equipment Inc

## Air Curtains

ADA Technologies Inc

## Air Emission Monitoring Equipment

A I W Inc  
Advanced Control Systems  
Air Instruments & Measurements Inc  
Air Metrics  
Air Monitor Corp  
Ametek Inc  
Ametek P & AI Div  
Anarad Inc  
Auburn International Inc  
SEE AD ON PAGE 53  
Bacharach Inc  
Balston Inc  
Bruel & Kjaer Instruments  
CAE Express  
CAE Instrument Rental  
CEA Instruments  
CTI Environmental Services  
California Analytical Instruments Inc  
Clean Air Engineering  
Climatronics Corp  
Coastal Environmental Systems  
Columbia Science Industries Co  
Columbia Scientific  
Control Instruments Corp  
Cosmos Gas Detection  
Dancer Communications Inc  
Dieterich Standard, a Dover Industries Co  
SEE AD ON PAGE 64  
Energy Efficiency Systems Inc  
SEE AD ON PAGE 11  
Engelhard Corp  
Entech Instruments  
Environmental Compliance Systems Corp  
Environmental Energy Services Inc (EES)  
Environmental Monitor Systems Inc  
Environmental Technologies Group

**ENVIROPLAN**  
201-994-2300

Envioplan Inc  
Fluid Components Intl  
Fluid Data Inc  
Foxboro Co, The  
SEE AD ON PAGE 46  
Geraghty & Miller Inc A Heimdig Co  
HNU Systems Inc  
Handar  
Hazco Services Inc  
Health Consultants Inc  
SEE AD ON PAGE 142  
Horiba Instruments Inc  
SEE AD ON PAGE 44  
Hull Corp Environmental Products Div  
Intek Corp/Rent-Alyzer  
International Sensor Technology

LINC Quantum Analytics  
 MKS Instruments Inc  
 McNeill International  
 Midac Corp  
 Midwesco Filter Resources Inc  
**Milco Safety Rental**  
**SEE AD ON PAGE 64**  
 Monarch Instrument  
 Monitor Labs Inc  
 OI Analytical  
**Omega Engineering Inc**  
**SEE AD ON PAGE 2**  
 PACE Environmental Products  
**Pallflex Products Co**  
**SEE AD ON PAGE 34**  
 Panametrics PCI Div  
 Perkin-Elmer Corp  
 Radian Corp  
 Response Rentals  
 Rosemount Analytical Inc  
 Sensidyne Inc  
 Servomex Co Inc  
 Siemens Industrial Automation Inc  
 Telebyte Brown Engineering - Control Applications  
 Thermo Environmental Instruments  
 United Sciences Inc  
 Universal Enterprises Inc  
 Wheelabrator Environmental Systems Inc  
 Zink, John Co Div of Koch Engineering Co Inc

**Air Emissions Testing**

AE Environmental Services Inc  
 ATEC Associates Inc  
 Accredited Laboratories Inc  
 Ambient Engineering Inc  
 American Scientific Instrumentation  
 Applied Science & Technology Inc  
 Barr Engineering Co  
 Blasland Bouck & Lee Inc  
 Braun Intertec Corp  
 Burns & McDonnell  
 CTL Environmental Services  
 Center for Hazardous Materials Research  
 Chester Environmental  
 Clean Air Engineering  
 Climatronics Corp  
 Corporation for Environmental Management  
 Cosmos Gas Detection  
 Dames & Moore  
 Detail Associates Inc  
 Dixon Environmental Associates Inc  
 EA Engineering, Science & Technology Inc  
 ERM Group, The  
 ERM-South Inc  
 Eckenfelder  
 Ecom America Ltd  
 Enercon Services Inc  
 Entech Instruments  
 Entropy Inc  
 Enviro-Sciences Inc  
 Environmental Energy Services Inc (EES)  
 Environmental Monitor Systems Inc  
 Environmental Standards Inc  
 Environmental Technologies Group  
 FBA Environmental Inc  
 Galson Corp  
 Gascoyne Laboratories Inc  
 Geraghty & Miller Inc A Heidmij Co  
 Graef Anhalt Schloemer  
 Hart Crowser Inc  
**Health Consultants Inc**  
**SEE AD ON PAGE 142**  
 Hill International Inc  
**Horiba Instruments Inc**  
**SEE AD ON PAGE 44**  
 International Technology Corp  
 K & B Design Inc  
**Lancaster Laboratories Inc**  
**SEE AD ON PAGE 7**  
 Mabbett & Associates Inc  
 Natisco

O'Brien & Gere Technical Services Inc  
 Ogden Environmental & Energy Services  
 Oxford Environmental Inc  
 Pacific Analytical Inc  
 Panametrics PCI Div  
 Parsons Engineering Science Inc  
 Perkin-Elmer Corp  
 R E Wright Associates Inc (REWI)  
 RMT Inc  
 Radian Corp  
 Raytheon Engineers & Constructors/Raytheon Enviro Svc  
 Recon Environmental  
 Resource Consultants Inc  
 Response Rentals  
 Rust Environment & Infrastructure  
 Rust International Inc  
 SSM/Spotts Stevens & McCoy Inc  
 Soil & Material Engineers Inc  
 Stanley Consultants Inc

**TENEREX CORP.**  
**713-482-5801**

Tenex Corp  
 Terra Bio Chem Environmental & Engineering Services Inc  
 Trans-Enviro Inc  
 Universal Enterprises Inc  
 Wheelabrator Environmental Systems Inc

**Air Exhaust Noise Control**

BRD Noise & Vibration Control Inc  
 Maxim Engineers Inc  
 O'Brien & Gere Technical Services Inc  
 Ogden Environmental & Energy Services  
 Raytheon Engineers & Constructors/Raytheon Enviro Svc  
 United McGill Corp

**Air Filters**

AAF International  
 Aerology Inc

**AMERI-CAN EN ENGINEERING**  
**219-892-5151**

American Engineering  
 American Environmental International Inc  
 Anderson 2000 Inc  
 Anguil Environmental Systems Inc  
 Balston Inc  
 Biosystems  
 Cameron-Yakima Inc  
 Captair LabX Inc  
 Chemco Mtg Co Inc  
 Cole-Palmer Instrument Co  
 Dival Safety Equipment  
 Ducon Environmental Systems Inc  
 EPG Companies Inc  
 Engelhard Corp  
 Envirogen Inc  
 Environmental Products & Services Inc  
 Equinox International  
 Extech Instruments  
 Ferro Corp, Specialty Ceramics Div/Filtros Plant  
 General Carbon Corp  
 Harborlite Corp  
 JBI Spray Booth Systems  
 La-Man Corp  
 Micro Air, Air Cleaners by Metal-Fab Inc  
 Midwesco Filter Resources Inc

**Monsanto Enviro-Chem**  
**314-275-5700**

Monsanto Enviro-Chem  
 Norit Americas Inc  
 Northwestern Carbon

**Osmonics Inc**  
**SEE AD ON PAGE 31**

**Pallflex Products Co**  
**SEE AD ON PAGE 34**  
**Parker Hannifin Corp**  
**SEE AD ON PAGE 144**

Schuller International Inc  
 Spraying Systems Co  
 Terra Universal  
 3M Filtration Products  
 W L Gore & Associates Inc  
 Wheelabrator Environmental Systems Inc

**Air Make-up Units**

Hartzell Fan Inc  
 JBI Spray Booth Systems  
 Stanley Consultants Inc

**Air Quality Instrumentation**

A I W Inc  
 Air Instruments & Measurements Inc  
 Air Metrics  
 Air Resource Specialists Inc  
 Alnor Instrument Co  
 American Scientific Instrumentation  
 Ariel Industries Inc  
 Arizona Instrument Corp  
 Bacharach Inc  
 Bruel & Kjaer Instruments  
 CAE Express  
 CAE Instrument Rental  
 CEA Instruments  
 Coastal Air Engineering  
 Climatronics Corp  
 Coastal Environmental Systems  
 Columbia Science Industries Co  
 Cosmos Gas Detection  
 Dasibi Environmental Corp  
 Datatest Corp  
 Dickson Co, The  
 ENMET Corp  
 Eastern Technical Associates  
**Energy Efficiency Systems Inc**  
**SEE AD ON PAGE 11**  
 Engelhard Corp  
 Entech Instruments Inc  
 Environics  
 Environmental Health & Engineering Inc  
 Environmental Monitor Systems Inc  
 Environmental Technologies Group  
 Enviroplan Inc  
**Foxboro Co, The**  
**SEE AD ON PAGE 46**  
**H-I-Q Environmental Products Co**  
**SEE AD ON PAGE 47**

Handar  
 Hazco Services Inc  
 Intek Corp/Rent-Alyzer  
 International Sensor Technology  
 LINC Quantum Analytics  
 McNeill International  
 Metrosonics Inc  
 Microsensor Systems Inc  
 Midwesco Filter Resources Inc  
 Monitor Labs Inc  
 Morehouse-Cowles Inc  
 National Draeger Inc  
 Neotronics  
 NovaLynx Corp  
 OI Analytical

**Omega Engineering Inc**  
**SEE AD ON PAGE 2**  
 Perkin-Elmer Corp  
**Photovac Monitoring Instruments**  
**SEE AD ON PAGE 42**  
**R M Young Co**  
**SEE AD ON PAGE 47**

Radian Corp  
 Response Rentals  
 Rosemount Analytical Inc  
 Sensidyne Inc  
 Sentex Systems Inc

Servomex Co Inc  
 Siemens Industrial Automation Inc  
 Sierra Monitor Corp  
 Solomat  
 TSI Inc/Environmental Measurements & Controls Div  
 Wheelabrator Environmental Systems Inc

**Air Pollution Control Equipment**

AAF International  
**ABB Air Preheater Inc**  
**SEE AD ON PAGE 141**  
 AGA Gas Inc

**ADVANCED E D**  
**708-394-9553**

Advanced Air Tech Inc  
 Advanced Industrial Technology Corp  
**Adwest Technologies Inc**  
**SEE AD ON PAGE 36**

Aerology Inc  
 Aget Manufacturing Co  
 Air Metrics  
 Air Plastics Inc  
 Airex Div Adwest Technologies  
 Airotech  
 Ambient Engineering Inc  
 American Environmental International Inc  
 American Gas Products Inc  
 Anguil Environmental Systems Inc  
 Atlantic Ultraviolet Corp  
**Auburn International Inc**  
**SEE AD ON PAGE 53**  
 Babcock & Wilcox  
 Beltran Associates Inc

**BOHN BIOFILTER CORP.**  
**(602) 624-4644**

Bohn Biofilter Corp  
 Breslow Separator Co Inc  
 CMI-Schneible Co  
 CSM Environmental Systems Inc  
 CVM Corp  
 Calgon Carbon Corp  
 Cameron-Yakima Inc  
 Captair LabX Inc  
 Carbon Activated  
 Carbon Service & Equipment Co  
 Clean Air Engineering  
 Climatronics Corp  
 Control Instruments Corp  
 Croll Reynolds Co Inc  
 DCE Inc  
 Dancer Communications Inc  
 Dasibi Environmental Corp  
 Datatest Corp  
 Denver Mineral Engineers Inc  
 Duall Div Met-Pro Corp  
 Ducon Environmental Systems Inc

**DURA**  
**313-459-6800**

Durr Industries Inc  
 EPG Companies Inc  
 ERS Services  
 Entech Instruments Inc  
 Entoleter Inc  
 Envirogen Inc  
 Environics  
 Environmental Techniques  
 Environmental Technologies Group  
 Feco Engineered Systems Inc  
 General Carbon Corp  
 Glenro Inc  
 Grace TEC Systems  
 Griffin Environmental Co Inc  
 H2 Oil Recovery Equipment Inc  
 Hazzo Services Inc

High Voltage Environmental  
 ILC Dover Inc  
 Intek Corp/Rent-Alyzer  
 International Sensor Technology  
 JBI Spray Booth Systems  
 Keoco R & D Inc  
 MAC Environmental A Div of MAC Equipment Inc  
 MMT Environmental Services Inc  
 Martin Marietta Magnesia Specialties Inc  
 McNeill International  
 Membrane Technology & Research Inc  
**Met-One Instruments Inc**  
**SEE AD ON PAGE 26**  
**Met-Pro Corp Systems Div**  
**SEE AD ON PAGE 43**  
 Micro Air, Air Cleaners by Metal-Fab Inc  
 Midwesco Filter Resources Inc  
 Misonix Inc  
 Monarch Separators Inc  
 Monitor Labs Inc  
 Monroe Environmental Corp

**Monsanto Enviro-Chem**  
**314-275-5700**

Monsanto Enviro-Chem  
 Morlan & Morlan Inc  
 NAO Inc  
 NST Engineers  
 Nalco Fuel Tech  
 Nederman Inc  
 Norit Americas Inc  
 North East Environmental Products Inc  
 Norton Chemical Process Products Corp  
 NovaLynx Corp  
 Noxco Corp  
**Omega Engineering Inc**  
**SEE AD ON PAGE 2**

Pentek Inc  
 Purus Inc  
 Recon Environmental  
 Ross Air Systems  
 Schutte & Koerting Division Ketema Inc  
 Sensidyne Inc  
 Sierra Monitor Corp  
 Spraying Systems Co  
 Tellkamp Systems Inc  
 Thermotron  
 Tri-Mer Corp  
 Trion Inc  
 Turner EnviroLogic Inc  
 United Air Specialist  
 United McGill Corp  
 United Sciences Inc  
 Vara Intl Div of Calgon Carbon Corp  
 W L Gore & Associates Inc  
 W R Grace - Grace Emission Control  
 Wheelabrator Air Pollution Control  
 Wheelabrator Environmental Systems Inc  
 Winsor & Jerauld  
 Wolverine (Massachusetts) Corp  
 Zink, John Co Div of Koch Engineering Co Inc  
 Zurn Industries, Air Systems Div

**Air Samplers**

A P Buck Inc  
 AE Environmental Services Inc  
 Air Metrics  
 Airscan Environmental Technologies Inc  
 Ariel Industries Inc  
 Arizona Instrument Corp  
 Bacharach Inc  
 Bios Intl  
 CEA Instruments  
 CTL Environmental Services  
 Clean Air Engineering  
 Climatronics Corp  
 Cole-Parmer Instrument Co  
 Dival Safety Equipment  
 Eastern Technical Associates  
 Entech Instruments Inc  
 Environmental Health & Engineering Inc

Environmental Monitor Systems Inc  
**Foxboro Co, The**  
**SEE AD ON PAGE 46**

Gilian Instrument Corp  
**HI-Q Environmental Products Co**  
**SEE AD ON PAGE 47**

Hazco Services Inc  
 Intek Corp/Rent-Alyzer  
 Lab Safety Supply  
 M-Tec Corp  
 MKS Instruments Inc  
 MSA  
 NovaLynx Corp  
 Nuclear Associates  
 OI Analytical  
 Ogden Environmental & Energy Services  
**Omega Engineering Inc**  
**SEE AD ON PAGE 2**

**Photovac Monitoring Instruments**  
**SEE AD ON PAGE 42**

Response Rentals  
 SKC Inc  
 Sensidyne Inc  
 Siemens Industrial Automation Inc  
 Sierra Monitor Corp  
 Spectrum Chemical & Safety Products  
 Staplex - Air Sampler Div  
 Trans-Enviro Inc  
 Whatman Inc  
 Wheelabrator Environmental  
 Systems Inc  
 Wonder Makers Inc

**Air Strippers**

AWD Technologies Inc

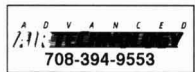

Advanced Air Tech Inc  
 Advanced Industrial Technology Corp  
 Aeromix Systems Inc  
 Air Plastics Inc  
 Anderson 2000 Inc  
 BioTrol Inc  
 Carbonair Environmental Systems  
 Carbtrol Corp  
**Delta Cooling Towers Inc**  
**SEE AD ON PAGE 62**

Denver Mineral Engineers Inc  
 Duall Div Met-Pro Corp  
 Ducon Environmental Systems Inc  
 EPG Companies Inc  
 ERM-South Inc  
**Ejector Systems Inc**  
**SEE AD ON PAGE 52**

Environmental Products & Services Inc  
 Environmental Protection Systems  
**Environmental Restoration  
 Systems Inc**  
**SEE AD ON PAGE 18**

GeoPure Contentional Systems & Services  
 Global Water  
 H2 Oil Recovery Equipment Inc  
 Hazleton Environmental  
 Hydro Group  
 International Technology Corp  
 Jaeger Products Inc  
 Misonix Inc  
 National Environmental Systems Inc  
 North East Environmental Products Inc  
 O'Brien & Gere Technical Services Inc  
 ORS Environmental Systems  
 QED GroundWater Specialists  
 R E Wright Associates Inc (REWI)  
 Remedial Systems Inc  
 Tri-Mer Corp  
**Unipure Environmental**  
**SEE AD ON PAGE 10**

Wheelabrator Environmental  
 Systems Inc

**Air Velocity Meter**

Air Monitor Corp  
 Barnant Co

Ben Meadows  
 CAE Express  
 CAE Instrument Rental  
 Climatronics Corp  
 Cole-Parmer Instrument Co  
 Dwyer Instruments Inc  
 Engelhard Corp  
 Epic Inc  
 Fluid Components Intl  
**HI-Q Environmental Products Co**  
**SEE AD ON PAGE 47**

Hazco Services Inc  
 Midwesco Filter Resources Inc  
 Neotronics  
 NovaLynx Corp  
**Omega Engineering Inc**  
**SEE AD ON PAGE 2**

Qualimetrics Inc  
 Response Rentals  
 Shortridge Instruments Inc  
 Solomat  
 Terra Universal  
 TSI Inc/Environmental Measurements &  
 Controls Div  
 Universal Enterprises Inc

**Alternative Energy  
 Process**

Leslie Mfg Inc

**Anaerobic Pretreatment**

AquaTec Inc  
 BioTrol Inc  
 Fluidyne Corp  
 LEXICON Environmental Associates Inc  
**National Technical Systems Inc**  
**SEE AD ON PAGE 17**

O'Brien & Gere Technical Services Inc  
 Terra Bio Chem Environmental &  
 Engineering Services Inc

**Analysis, Atomic  
 Absorption**

ASTB/Analytical Services Inc  
 Accredited Laboratories Inc  
 American Standards Testing Bureau Inc  
 Applied Research & Development Lab  
 Atlantic Testing Laboratories Limited  
 B & W NESI NEL  
 CTL Environmental Services  
 Clean Venture/Cycle Chem  
 Compu Chem Environmental Corp  
 Con-Test  
 EA Engineering, Science  
 & Technology Inc  
 ELB & Associates  
 Eckenfelder  
 Eco Tek Laboratory Services Inc  
 Foppe Thelen Group Inc  
 GTEL Environmental Laboratories  
 Gascoyne Laboratories Inc  
 H E S Inc  
 Heritage Environmental Services Inc  
 Huntington Engineering  
 & Environmental Inc

**Lancaster Laboratories Inc**  
**SEE AD ON PAGE 7**

Neslab Instruments Inc  
 Nytest Environmental Inc  
 Peoria Disposal Co  
 Professional Analytical & Consulting  
 Services Inc  
 Raytheon Engineers &  
 Constructor/Raytheon Enviro Svc  
 SSM/Spotts Stevens & McCoy Inc  
 Triangle Laboratories Inc  
 Trinity Environmental Technologies  
 Ultra Scientific Inc  
 Waste Stream Technology Inc

**Analysis, Electron  
 Microscopy**

ASTB/Analytical Services Inc  
 ATEC Associates Inc  
 American Standards Testing Bureau Inc

Braun Intertec Corp  
 CTL Environmental Services  
 Compu Chem Environmental Corp  
 Galson Corp  
 Hill International Inc  
 Hitachi Scientific Instruments  
 Huntington Engineering  
 & Environmental Inc  
**Lancaster Laboratories Inc**  
**SEE AD ON PAGE 7**

**Analysis, Gas  
 Chromatography**

AE Environmental Services Inc  
 ASTB/Analytical Services Inc  
 ATEC Associates Inc  
 Accredited Laboratories Inc  
 American Scientific Instrumentation  
 American Standards Testing Bureau Inc  
 Applied Research & Development Lab  
 Assay Technology Inc  
 Atlantic Testing Laboratories Limited  
 B & W NESI NEL  
 BioTrol Inc  
 Braun Intertec Corp  
 Brown & Root Environmental  
 CTL Environmental Services  
 Clean Air Engineering  
 Clean Venture/Cycle Chem  
 Cole-Parmer Instrument Co  
 Compu Chem Environmental Corp  
 Con-Test  
 E S E Bioscience  
 E S Industries  
 EA Engineering, Science  
 & Technology Inc  
 ELB & Associates  
 ES Industries  
 Eckenfelder  
 Eco Tek Laboratory Services Inc  
 Environmental Fuel Systems Inc  
 Environmental Products & Services Inc  
 Fluid Data Inc  
 Foppe Thelen Group Inc  
**Foxboro Co, The**  
**SEE AD ON PAGE 46**

GTEL Environmental Laboratories  
 Galson Corp  
 Gascoyne Laboratories Inc  
 Global Environmental Inc  
 H E S Inc  
 Heritage Environmental Services Inc  
 Huntington Engineering  
 & Environmental Inc  
**Lancaster Laboratories Inc**  
**SEE AD ON PAGE 7**

Neslab Instruments Inc  
 Nytest Environmental Inc  
 Ogden Environmental & Energy Services  
 Pacific Analytical Inc  
 Peoria Disposal Co  
 Professional Analytical & Consulting  
 Services Inc  
 R E Wright Associates Inc (REWI)  
 Raytheon Engineers &  
 Constructor/Raytheon Enviro Svc  
 Restek Corp  
 Rollins Environmental  
 SRI Instruments  
 SSM/Spotts Stevens & McCoy Inc  
 Sentex Systems Inc  
 Trans-Enviro Inc  
 Triangle Laboratories Inc  
 Trinity Environmental Technologies  
 Ultra Scientific Inc  
 Universal Sensors & Devices Inc  
 Waste Stream Technology Inc

**Analysis, Gas  
 Chromatography/Mass  
 Spectrometry**

AE Environmental Services Inc  
 ASTB/Analytical Services Inc  
 ATEC Associates Inc  
 AWD Technologies Inc  
 Accredited Laboratories Inc  
 American Standards Testing Bureau Inc  
 Applied Research & Development Lab  
 Arthur D Little Inc  
 Atlantic Testing Laboratories Limited  
 B & W NESI NEL  
 Braun Intertec Corp  
 Brown & Root Environmental  
 Cole-Parmer Instrument Co  
 Compu Chem Environmental Corp  
 Con-Test  
 EA Engineering, Science  
 & Technology Inc  
 ENSCI Environmental Inc  
 Eckenfelder  
 Eco Tek Laboratory Services Inc  
 Environmental Monitor Systems Inc  
 Environmental Products & Services Inc  
 Foppe Thelen Group Inc  
 GTEL Environmental Laboratories  
 Galson Corp  
 Gascoyne Laboratories Inc  
 H E S Inc  
 Huntington Engineering  
 & Environmental Inc  
**Lancaster Laboratories Inc**  
**SEE AD ON PAGE 7**

Neslab Instruments Inc  
 Nytest Environmental Inc  
 Ogden Environmental & Energy Services  
 Pacific Analytical Inc  
 Peoria Disposal Co  
 Professional Analytical & Consulting  
 Services Inc  
 R E Wright Associates Inc (REWI)  
 Raytheon Engineers &  
 Constructor/Raytheon Enviro Svc  
 Rollins Environmental  
 SRI Instruments  
 SSM/Spotts Stevens & McCoy Inc  
 Spectraserv

**Tracer Research Corporation**

**1-800-394-9929**

Tracer Research Corp  
 Trans-Enviro Inc  
 Triangle Laboratories Inc  
 Trinity Environmental Technologies  
 Ultra Scientific Inc  
 Waste Stream Technology Inc

**Analysis, Liquid  
 Chromatography**

AE Environmental Services Inc  
 ASTB/Analytical Services Inc  
 American Standards Testing Bureau Inc  
 Applied Research & Development Lab  
 Assay Technology Inc  
 Bacharach Inc  
 BioTrol Inc  
 CTL Environmental Services  
 Cole-Parmer Instrument Co  
 Compu Chem Environmental Corp  
 Dionex Corp  
 E S Industries  
 EA Engineering, Science  
 & Technology Inc  
 Eco Tek Laboratory Services Inc  
 Engelhard Corp  
 Fluid Data Inc  
**Foxboro Co, The**  
**SEE AD ON PAGE 46**

GTEL Environmental Laboratories  
 General Analysis Corp  
 H E S Inc  
 Huntington Engineering

& Environmental Inc  
**Lancaster Laboratories Inc**  
**SEE AD ON PAGE 7**

Neslab Instruments Inc  
 Pacific Analytical Inc  
 Peoria Disposal Co  
 Professional Analytical & Consulting  
 Services Inc  
 R E Wright Associates Inc (REWI)  
 Raytheon Engineers &  
 Constructor/Raytheon Enviro Svc  
 Restek Corp  
 Rollins Environmental  
 SSM/Spotts Stevens & McCoy Inc  
 Spectrum Medical Industries  
 Trans-Enviro Inc  
 Triangle Laboratories Inc  
 Ultra Scientific Inc

**Analysis, Soil, Water, Air**

AE Environmental Services Inc  
 ASTB/Analytical Services Inc  
 ATEC Associates Inc  
 AWD Technologies Inc  
 Aaron Environmental Services Corp  
 Accredited Laboratories Inc  
 Air Instruments & Measurements Inc  
 Alton Geoscience  
 American Standards Testing Bureau Inc  
 Applied Research & Development Lab  
 Arthur D Little Inc  
 Atlantic Testing Laboratories Limited  
 B & W NESI NEL  
 Ben Meadows  
 BioTrol Inc  
 Bioscience Inc  
 Book Environmental Service Inc  
 Braun Intertec Corp  
 Brown & Root Environmental  
 CHEMetrics Inc  
 CTL Environmental Services  
 Chentrul Environmental Inc  
 Clean Venture/Cycle Chem  
 Cole-Parmer Instrument Co  
 Compu Chem Environmental Corp  
 Con-Test  
 E S E Bioscience  
 EA Engineering, Science  
 & Technology Inc  
 ECOSTAT Inc  
 ELB & Associates  
 ENSCI Environmental Inc  
 ERM Group, The  
 Eckenfelder  
 Eco Tek Laboratory Services Inc  
 Engelhard Corp  
 Ensys Environmental Products Inc  
 Entech Instruments  
 Environmental Products & Services Inc  
 Environmental Technologies Group  
 FBA Environmental Inc  
 Foppe Thelen Group Inc  
 Foster Wheeler Environmental Corp  
**Foxboro Co, The**  
**SEE AD ON PAGE 46**

GTEL Environmental Laboratories  
 Galson Corp  
 Gannett Fleming Inc  
 Gascoyne Laboratories Inc  
 General Analysis Corp  
 Graef Anhalt Schloemer  
 H E S Inc



Hach Co  
 Hart Crosser Inc  
 Heritage Environmental Services Inc  
 Hill International Inc  
 Huntington Engineering  
 & Environmental Inc  
**Lancaster Laboratories Inc**  
**SEE AD ON PAGE 7**

METCO Environmental

Maxim Engineers Inc  
National Draeger Inc  
**National Technical Systems Inc**  
SEE AD ON PAGE 17  
Nytest Environmental Inc  
Ogden Environmental & Energy Services  
**Omega Engineering Inc**  
SEE AD ON PAGE 2  
Pacific Analytical Inc  
Peoria Disposal Co  
Professional Analytical & Consulting Services Inc  
R E Wright Associates Inc (REW)  
Radian Corp  
Raytheon Engineers & Constructor/Raytheon Enviro Svc  
Recon-Environmental  
Restek Corp  
Rollins Environmental  
Rust Environment & Infrastructure  
Rust International Inc  
SRI Instruments  
Sensidyne Inc  
Sentex Systems Inc  
Sewall, James W Co  
Spectraserv  
Teledyne Brown Engineering - Environmental Services  
Terra Bio Chem Environmental & Engineering Services Inc  
Trans-Enviro Inc  
Traverse Group, The  
Triangle Laboratories Inc  
Trinity Environmental Technologies  
Ultra Scientific Inc  
Waste Stream Technology Inc  
Wonder Makers Inc

**Analytical Instruments, Air**

Air Instruments & Measurements Inc  
Air Resource Specialists Inc  
Ametek Inc  
Anarad Inc  
Antek Instruments Inc  
Ariel Industries Inc  
Arizona Instrument Corp  
Ben Meadows  
Bruel & Kjaer Instruments  
CAE Instrument Rental  
CEA Instruments  
Clean Air Engineering  
Climatronics Corp  
Columbia Science Industries Co  
Columbia Scientific  
Control Instruments Corp  
Dasibi Environmental Corp  
Datastat Corp  
Dival Safety Equipment  
Dyna-Fid Inc

**Energy Efficiency Systems Inc**  
SEE AD ON PAGE 11

ENMET Corp  
ES Industries  
Entech Instruments Inc  
Environmental Monitor Systems Inc  
Environmental Technologies Group  
Finnigan/Tremetrics  
Fisher Scientific Safety Products Div  
**Foxboro Co, The**  
SEE AD ON PAGE 46

**HI-Q Environmental Products Co**  
SEE AD ON PAGE 47

Handar  
Hazco Services Inc  
**Horiba Instruments Inc**  
SEE AD ON PAGE 44  
Hull Corp Environmental Products Div  
Instec Inc  
Intek Corp/Rent-Alyzer  
Lab Safety Supply  
MKS Instruments Inc  
McNeill International  
Microsensor Systems Inc  
Midwestco Filter Resources Inc  
National Draeger Inc

Nova Analytical Systems Inc  
NovaLynx Corp  
Nuclear Associates  
OI Analytical  
**Omega Engineering Inc**  
SEE AD ON PAGE 2  
Panametrics PCI Div  
Perkin-Elmer Corp  
**Photovac Monitoring Instruments**  
SEE AD ON PAGE 42  
Response Rentals  
Rosemount Analytical Inc  
SRI Instruments  
Sensidyne Inc  
Sentex Systems Inc  
Servomex Co Inc  
Sierra Monitor Corp  
Solomat  
Superior Signal Co Inc  
Trans-Enviro Inc  
Universal Enterprises Inc  
Varian Instruments  
Wheelabrator Environmental Systems Inc

**Analytical Instruments, Hazardous Materials**

AE Environmental Services Inc  
AIM Safety USA Inc  
Ametek Inc  
CEA Instruments  
Clean Venture/Cycle Chem  
Control Instruments Corp  
Dival Safety Equipment  
ENMET Corp  
ES Industries  
Electrosynthesis Co  
Engelhard Corp  
Ensys Environmental Products Inc  
Environmental Monitor Systems Inc  
Environmental Technologies Group  
Fisher Scientific Safety Products Div  
Fluid Data Inc  
**Foxboro Co, The**  
SEE AD ON PAGE 46

**Group 206 Technologies Inc**  
SEE AD ON PAGE 42

Hazco Services Inc  
LINC Quantum Analytics  
Lab Safety Supply  
Millipore Corp  
**Omega Engineering Inc**  
SEE AD ON PAGE 2  
Perkin-Elmer Corp  
Response Rentals  
Sensidyne Inc  
Sentex Systems Inc  
Servomex Co Inc  
Sierra Monitor Corp  
Trans-Enviro Inc

**Analytical Instruments, Rentals**

American Scientific Instrumentation  
CAE Instrument Rental  
Dyna-Fid Inc  
ES Industries  
Engelhard Corp  
Environmental Monitor Systems Inc  
Environmental Technologies Group  
Hazco Services Inc  
Intek Corp/Rent-Alyzer  
LINC Quantum Analytics  
Millipore Corp  
Pace Transducer/CJ Enterprise  
Professional Analytical & Consulting Services Inc  
R E Wright Associates Inc (REW)  
Response Rentals  
SRI Instruments  
Sentex Systems Inc

**Analytical Instruments, Wastewater**

AE Environmental Services Inc  
American Sigma Inc

Anatel Corp  
Antek Instruments Inc  
Arthur Technology Inc  
Bailey Controls Co  
Bailey-Fischer & Porter Co  
Ben Meadows  
Bioscience Inc  
Bran & Luebbe Inc  
CHEMetrics Inc  
Capital Controls Co Inc  
Clean Air Engineering  
Clean Venture/Cycle Chem  
Cole-Parmer Instrument Co  
Control Instruments Corp  
Dionex Corp  
E S Industries  
Electrosynthesis Co  
Engelhard Corp  
Entech Instruments  
Finnigan/Tremetrics  
Fluid Data Inc  
Global Water  
H F Scientific Inc



Hach Co  
Hazco Services Inc  
**Horiba Instruments Inc**  
SEE AD ON PAGE 44

Invalco Inc  
Keco R & D Inc  
LINC Quantum Analytics  
Lab Safety Supply  
Millipore Corp  
NovaLynx Corp  
OI Analytical  
**Omega Engineering Inc**  
SEE AD ON PAGE 2  
Orbeco Analytical Systems Inc  
Perkin-Elmer Corp  
Perstorp Analytical Inc  
**Photovac Monitoring Instruments**  
SEE AD ON PAGE 42

ProMinent Fluid Controls Inc  
Response Rentals  
SRI Instruments  
Sensidyne Inc  
Sentex Systems Inc  
Taylor Technologies  
Varian Instruments  
Wheaton Science Products  
YSI Inc

**Analytical Instruments, Water**

Antek Instruments Inc  
Bailey Controls Co  
Bailey-Fischer & Porter Co  
Ben Meadows  
CHEMetrics Inc  
Capital Controls Co Inc  
Cole-Parmer Instrument Co  
Dionex Corp  
ENMET Corp  
ES Industries  
Electrosynthesis Co  
Entech Instruments  
Finnigan/Tremetrics  
Global Water  
Group 206 Technologies Inc  
H F Scientific Inc  
HNU Systems Inc



Hach Co  
Handar  
Hazco Services Inc  
**Horiba Instruments Inc**  
SEE AD ON PAGE 44  
**Hydrolab Corp**

**SEE AD ON PAGE 22**

Intek Corp/Rent-Alyzer  
Invalco Inc  
Ionics Inc  
LINC Quantum Analytics  
Lab Safety Supply  
Microbics Corp  
Millipore Corp  
Nova Analytical Systems Inc  
NovaLynx Corp  
OI Analytical  
**Omega Engineering Inc**  
SEE AD ON PAGE 2  
Orbeco Analytical Systems Inc  
Perkin-Elmer Corp  
Perstorp Analytical Inc  
ProMinent Fluid Controls Inc  
Response Rentals  
Rosemount Analytical  
SRI Instruments  
Sensidyne Inc  
Sentex Systems Inc  
Sleivers Instruments Inc  
Solomat  
Taylor Technologies  
Thornton Associates Inc  
Turner Designs  
Varian Instruments  
YSI Inc

**Analytical/Research Services**

AE Environmental Services Inc  
ASTB/Analytical Services Inc  
American Standards Testing Bureau Inc  
Andco Environmental Processes Inc  
BioTrol Inc  
Brown & Root Environmental  
Compu Chem Environmental Corp  
E S Industries  
EA Engineering, Science & Technology Inc  
Eckelfelder  
Eco Tek Laboratory Services Inc  
Electrosynthesis Co  
Ensys Environmental Products Inc  
Environex  
GTEL Environmental Laboratories  
Gascayne Laboratories Inc  
Genium Publishing Corp  
GeoSyntec Consultants  
H E S Inc  
Hart Crowsier Inc  
Heritage Environmental Services Inc  
**Lancaster Laboratories Inc**  
SEE AD ON PAGE 7

Maxim Engineers Inc  
Nytest Environmental Inc  
Ogden Environmental & Energy Services  
Professional Analytical & Consulting Services Inc  
Professional Service Industries Inc  
Raytheon Engineers & Constructor/Raytheon Enviro Svc  
Rollins Environmental  
Structure Probe Inc/SPI Supplies  
Triangle Laboratories Inc  
Waste Stream Technology Inc

**Annunciators/Alarms**

Acromag Inc  
Ametek Inc/Panalarm Div  
**Auburn International Inc**  
SEE AD ON PAGE 53  
Dancer Communications Inc  
Invention Inc  
Kaye Electronics Inc  
Newport Electronics Inc  
Phonetics Inc  
Sierra Monitor Corp  
Soil & Material Engineers Inc

**Aquifer Restoration**

Alton Geoscience  
Bioscience Inc

E S E Bioscience  
EA Engineering, Science & Technology Inc  
EPG Companies Inc  
Eckelfelder  
EcoTech Inc  
Environmental Products & Services Inc  
**Environmental Restoration Systems Inc**  
SEE AD ON PAGE 18

Environmental Standards Inc  
Geotrans Inc  
Groundwater Technology Inc  
Hart Crowsier Inc  
Horizontal Technologies Inc  
Hydro-Terra Inc  
International Technology Corp  
LEXICON Environmental Associates Inc  
Lindmark Engineering Inc  
**National Technical Systems Inc**  
SEE AD ON PAGE 17  
O'Brien & Gere Technical Services Inc  
R E Wright Associates Inc (REW)  
Rust Environment & Infrastructure  
Rust International Inc  
Smith & Loveless Inc  
Superior Environmental Corp  
Traverse Group, The

**Asbestos Abatement Services/Equipment**

AE Environmental Services Inc



American Engineering  
Applied Science & Technology Inc  
B A G Corp  
Baker Tanks  
CRX Environmental Services Inc  
CTL Environmental Services  
Chentral Environmental Inc  
Coastwide Environmental Technologies Inc  
Covino Environmental Consulting Inc  
Dames & Moore  
Dival Safety Equipment  
Enercon Services Inc  
Envirowisn Group Inc, The  
Fiberlock Technologies Inc  
Gilian Instrument Corp  
Graying Industries  
Guzzler Mtg Inc  
Inflatable Abatement Systems Inc  
International Protective Coatings Corp  
International Safety Instruments  
International Technology Corp  
Jaca Corp  
LEXICON Environmental Associates Inc  
Lab Safety Supply  
M-Tec Corp  
Minuteman Intl Inc  
National Marker Co  
Neotek Health Technologies Inc  
North Safety Products  
North Safety Products, Safety Equipment Div  
Occupational Health & Hygiene Corp of America  
Packaging Research & Design  
Professional Service Industries Inc  
R E Wright Associates Inc (REW)  
RMT Inc  
SSM/Spotts Stevens & McCoy Inc  
Sensidyne Inc  
Stanley Consultants Environmental Inc  
Staplex - Air Sampler Div  
Sverdrup Environmental Inc  
Terra Bio Chem Environmental & Engineering Services Inc  
Vacuum Engineering  
Vector Technologies Ltd  
Versar Inc  
Wellington Environmental Consulting &

Construction Inc  
Wonder Makers Inc

**Backflow Preventers**

Flomatic Corp  
Hersey Products  
Jerman Waterworks Supply  
Marshall Industrial Technologies  
Measurement & Flow Control

**Bacteria/Enzymes**

Bacteria Concepts Inc

Bio-Systems Corp  
Bioscience Inc  
CET Environmental Services Inc  
Jet Inc  
Medina Agriculture Products Co Inc  
Polybac Corp  
Serengeti Environmental  
Sybron Chemicals Inc  
Waste Stream Technology Inc

**Bacteriological Supplies**

Bacteria Concepts Inc

**Baffles/Booms**

EIMCO Process Equipment Co  
Environetics Inc  
Gundle Lining Systems Inc  
Hyde Products Inc  
JBI Spray Booth Systems  
MPC Containment System Ltd  
Plastic Fusion Fabricators  
Sunshine Technology Corp  
Watersaver Co Inc

**Baghouse Monitoring**

ADA Technologies Inc  
Air Instruments & Measurements Inc

Auburn International Inc  
SEE AD ON PAGE 53

Burns & McDonnell  
Environmental Techniques  
Midwestco Filter Resources Inc  
Spectronics Corp  
Wheelabrator Environmental  
Systems Inc

**Baghouses**

AAF International  
Aget Manufacturing Co  
Airotech  
Burns & McDonnell

Cedarapids Inc A Raytheon Co  
College Research Corp (CORECO)  
DCE Inc  
Ducon Environmental Systems Inc  
Dustvent Inc  
ERS Services  
Environmental Techniques  
G E Co  
Griffin Environmental Co Inc  
Kinane Engineering  
MAC Environmental A Div of MAC  
Equipment Inc  
Midwestco Filter Resources Inc  
Morlan & Morlan Inc  
O'Brien & Gere Technical Services Inc  
United McGill Corp  
Universal Process Equipment Inc

Wheelabrator Air Pollution Control  
Wheelabrator Environmental  
Systems Inc  
Zurn Industries, Air Systems Div

**Balances**

Ben Meadows  
Cole-Parmer Instrument Co  
Fisher Scientific Safety Products Div  
Ohaus Corp

**Omega Engineering Inc**  
SEE AD ON PAGE 2

Perkin-Elmer Corp  
Terra Universal  
Wilkins-Anderson Co

**Balers**

Accurate Industries  
Ameri-Shred Corp  
Ben Meadows  
Bes-Pac Inc  
Clean Environment Equipment  
Diversified Well Products Inc

SEE AD ON PAGE 30

ELLE International Inc/Soiltest Products  
Div  
Hazzo Services Inc  
Horner Creative Products Inc  
J Y Mfg Inc/Cram-A-Lot  
MAC Corp/Satum Shredders  
Piqua Waste Equipment Inc  
Wheaton Science Products

**Barriers**

EASI-SET Industries  
Gems Sensors Div  
Horizontal Technologies Inc  
New Pig Corp

SEE AD ON PAGE 138

Presray Corp  
United McGill Corp

**Batching/Blending  
Systems**

Acron Inc  
Automation Products Inc  
Bailey Controls Co  
Intec Controls Corp  
Jerman Waterworks Supply  
Koch Engineering Co Inc  
National Bulk Equipment Inc  
**Omega Engineering Inc**  
SEE AD ON PAGE 2  
ProMinent Fluid Controls Inc  
Universal Process Equipment Inc  
Vibra Screw Inc

**Bentonite**

Claymax Corp  
Discoflop  
Diversified Well Products Inc  
SEE AD ON PAGE 30  
Engelhard Corp  
Forrer Supply Co Inc  
Spectrum Chemical & Safety Products

**Bin Discharger**

Acron Inc

Amfue!  
MAC Environmental A Div of MAC  
Equipment Inc  
Martin Engineering  
Mole Master Services Corp  
National Bulk Equipment Inc  
Process Solutions  
Vibra Screw Inc

**Bin/Hoppers**

Amadas Industries

Amfue!  
Chem-Tainer Industries  
Denver Mineral Engineers Inc  
Gurman Container & Supply Corp  
MAC Environmental A Div of MAC  
Equipment Inc  
Midwestco Filter Resources Inc  
National Bulk Equipment Inc  
Process Solutions  
Universal Process Equipment Inc  
Vac-U-Max  
Vibra Screw Inc  
Zimmerman Industries Inc

**Bioassay**

Commonwealth Biomonitoring  
EMPE Inc  
ERM Group, The  
Group 206 Technologies Inc  
International Technology Corp  
**Lancaster Laboratories Inc**  
SEE AD ON PAGE 7

**National Technical Systems Inc**

SEE AD ON PAGE 17  
Normandeau Associates, RMC  
Environmental Services Div  
Ogden Environmental & Energy Services  
Spectraserv  
Waste Stream Technology Inc

**Biological Testing  
Apparatus/Supplies**

Arthur Technology Inc  
Bacteria Concepts Inc  
Ben Meadows  
Bioscience Inc  
Engelhard Corp  
Gelok Intl Corp  
Polybac Corp  
Spectronics Corp

**Biomass Combustion**

Leslie Mfg Inc

**Bioremediation**

ABB Environmental Services Inc  
ATI  
AWD Technologies Inc  
Aaron Environmental Services Corp  
Alton Geoscience  
BEC Laboratories  
Bacteria Concepts Inc  
BioTrol Inc  
Bioscience Inc  
Blastrand Bouck & Lee Inc  
Braun Intertec Corp  
C2T Group Ltd  
CET Environmental Services Inc  
**Commercial Dexterity Ltd.**  
SEE AD ON PAGE 64

Deeco Inc  
E S E Bioscience  
EA Engineering, Science  
& Technology Inc  
ECOSTAT Inc  
EMPE Inc  
ENSCI Environmental Inc  
ERM Group, The  
Eckenfelder  
Ecotech Inc  
Enercon Services Inc  
Envirex  
Environmental Products & Services Inc  
Environvision Group Inc, The  
FERTECH Environmental Inc  
Fluidyne Corp  
Foppe Thelen Group Inc

Foster Wheeler Environmental Corp  
Geo-Technology Associates Inc  
Groundwater Technology Inc  
Hart Crowser Inc  
Hayward Baker Environmental  
Heritage Environmental Services Inc  
Hydro Group  
International Technology Corp  
LEXICON Environmental Associates Inc  
Lindmark Engineering Inc  
Medina Agriculture Products Co Inc  
Morrison, Knudsen Corp  
NST Engineers  
Nalco Chemical Co  
**National Technical Systems Inc**  
SEE AD ON PAGE 17

O'Brien & Gere Technical Services Inc  
Ogden Environmental & Energy Services  
PDG Environmental Inc  
Parsons Engineering Science Inc  
Polybac Corp  
R E Wright Associates Inc (REW)  
RMT Inc  
Radian Corp  
Raytheon Engineers &  
Constructor/Raytheon Enviro Svc  
Rust Environment & Infrastructure  
Rust International Inc  
SSM/Spotts Stevens & McCoy Inc  
Serengeti Environmental  
Sevenson Environmental Services Inc  
Soil & Material Engineers Inc  
Superior Environmental Corp  
Sverdrup Environmental Inc  
Sybron Chemicals Inc  
TRAK Environmental Group Inc  
Traverse Group, The  
United States Filter Corp  
W L Gore & Associates Inc  
Waste Stream Technology Inc

**Bird Control**

Bird-X Inc

**Blowers**

Aget Manufacturing Co  
Air Plastics Inc  
Anderson 2000 Inc  
Ben Meadows  
Blower Application Co  
Bralisford & Company  
Busch Inc  
Dival Safety Equipment

E G & G Rotron - Industrial Div  
EPG Companies Inc  
Environmental Products & Services Inc  
**Environmental Restoration  
Systems Inc**  
SEE AD ON PAGE 18

Fisher Scientific Safety Products Div  
Forrer Supply Co Inc  
G E Co  
Gardner Denver Machinery Inc  
Gast Manufacturing Corp  
H2 Oil Recovery Equipment Inc  
Lamson Corp  
M-D Pneumatics Div/Tithill Corp  
MAC Environmental A Div of MAC  
Equipment Inc  
Meyer WM W & Sons Inc  
Nalge Co  
New York Blower Co  
Roots Div/Dresser Industries  
Smith & Loveless Inc  
Stokes Vacuum Inc  
Susquehanna Valley Systems Inc (SVS)  
Sutorill/Duroflow/Gardner Denver

Terra Universal  
Tri-Mer Corp  
Universal Process Equipment Inc

**Blowers - Corrosion  
Resistant**

E G & G Rotron - Industrial Div

**Blowers - SVE and GWS**

E G & G Rotron - Industrial Div

**BOD Test Equipment**

Anatel Corp  
Baler Equipment Co  
Bioscience Inc

Eagle-Picher/Env Science & Technology  
Lab-Line Instruments Inc  
Orbeco Analytical Systems Inc  
Polybac Corp  
Wheaton Science Products  
Wilkins-Anderson Co  
YSI Inc

**Boiler Feedwater  
Treatment Equipment**

Bryan Steam Corp  
CHEMetrics Inc  
Capital Controls Co Inc  
Environmental Protection Systems  
Fluid Data Inc  
Hartzell Fan Inc  
Measurement & Flow Control  
Nalco Chemical Co  
Nautus Inc  
**Osmonics Inc**  
SEE AD ON PAGE 31

ProMinent Fluid Controls Inc  
Progressive Equipment Corp  
SWAN/Industries Analytics  
Smith & Loveless Inc  
Taylor Technologies  
United States Filter Corp  
Water Equipment Tech  
Wheelabrator Environmental  
Systems Inc

**Boilers**

Babcock & Wilcox  
Bryan Steam Corp  
Cleaver-Brooks  
Environmental Protection Systems  
G E Co  
Measurement & Flow Control  
Universal Process Equipment Inc

**Burners**

**Adwest Technologies Inc**  
SEE AD ON PAGE 36

Babcock & Wilcox  
College Research Corp (CORECO)  
ERS Services  
H2 Oil Recovery Equipment Inc  
NAO Inc

Process Combustion Corp  
Zink, John Co Div of Koch  
Engineering Co Inc

**Bushings**

**Bushings**

Boston Gear  
Dodge/Reliance Electric  
Engelhard Corp  
G E Co  
**Parker Hannifin Corp**  
SEE AD ON PAGE 144

**Calibration**

A P Buck Inc  
AE Environmental Services Inc  
American EnviroSpect Inc  
Bailey-Fischer & Porter Co  
Bios Intl  
Brooklyn Thermometer Co Inc  
Cole-Parmer Instrument Co  
Cosmos Gas Detection  
Dasibi Environmental Corp  
Dival Safety Equipment  
Environics  
Everest Interscience Inc  
G E Co  
General Monitors  
Hazzo Services Inc  
Kaye Instruments Inc  
Keoc R & D Inc  
MKS Instruments Inc  
Marshall Industrial Technologies  
McNeill International  
**Omega Engineering Inc**  
SEE AD ON PAGE 2  
PACE Environmental Products  
Professional Analytical & Consulting  
Services Inc  
Sensidyne Inc  
Soltec Corp  
Thornton Associates Inc

**Calorimeters**

Columbia Science Industries Co  
Columbia Scientific  
Fluid Data Inc  
Neslab Instruments Inc  
**Omega Engineering Inc**  
SEE AD ON PAGE 2  
Perkin-Elmer Corp  
Wilkins-Anderson Co

**Carbon Adsorption**

AWD Technologies Inc  
Activated Carbon Resources  
Air Plastics Inc  
American Environmental International Inc  
Barnebey & Sutcliffe Corp  
Calgon Carbon Corp  
Cameron-Yakima Inc  
Carbon Activated  
Carbon Service & Equipment Co  
Carbonair Environmental Systems  
Carbtrol Corp  
Denver Mineral Engineers Inc  
**Diversified Well Products Inc**  
SEE AD ON PAGE 30  
Dual Div Met-Pro Corp  
Duon Environmental Systems Inc



313-459-6800

Durr Industries Inc  
E S E Bioscience  
EPG Companies Inc  
Environmental Products & Services Inc  
General Carbon Corp  
GeoPure Continental Systems & Services  
Hydro Group  
International Technology Corp  
**Met-Pro Corp Systems Div**  
SEE AD ON PAGE 43  
Misonix Inc  
National Environmental Systems Inc  
Norit Americas Inc  
Northwestern Carbon

O'Brien & Gere Technical Services Inc  
Professional Analytical & Consulting  
Services Inc  
QED GroundWater Specialists  
Remco Engineering  
Remedial Systems Inc  
SKC Inc  
Superior Environmental Corp  
Tedder & Widheim Consultants Inc  
Telikamp Systems Inc



713-943-3753

Unisorb Corp  
Vana Intl Div of Calgon Carbon Corp  
Western Filter Co  
Zimpro Environmental Inc

**Carbon Dioxide Detectors**

Ametek Inc  
Anarad Inc  
Assay Technology Inc  
Bacharach Inc  
CAE Instrument Rental  
CEA Instruments  
California Analytical Instruments Inc  
Clean Air Engineering  
Cimatronics Corp  
Cole-Parmer Instrument Co  
Cosmos Gas Detection  
Dival Safety Equipment  
ENMET Corp  
Engelhard Corp  
Environmental Monitor Systems Inc  
Fisher Scientific Safety Products Div  
**Foxboro Co, The**  
SEE AD ON PAGE 46  
HNU Systems Inc  
Hazzo Services Inc  
**Horiba Instruments Inc**  
SEE AD ON PAGE 44  
Intek Corp/Rent-Alyzer  
LINC Quantum Analytics  
Lab Safety Supply  
MSA  
McNeill International  
Metrosonics Inc  
**Milco Safety Rental**  
SEE AD ON PAGE 64  
National Draeger Inc  
Neutronics  
Nova Analytical Systems Inc  
Response Rentals  
SKC Inc  
Sensidyne Inc  
Servomex Co Inc  
Siemens Industrial Automation Inc  
Sierra Monitor Corp  
Solomat  
Spectrum Chemical & Safety Products  
TSI Inc/Environmental Measurements &  
Controls Div  
Thermo Environmental Instruments

**Carbon Monoxide Detectors**

AIM Safety USA Inc  
Ametek Inc  
Bacharach Inc  
Bascom-Turner Instruments  
Biosystems  
CAE Instrument Rental  
CEA Instruments  
California Analytical Instruments Inc  
Clean Air Engineering  
Cimatronics Corp  
Cole-Parmer Instrument Co



201-575-9114

Control Instruments Corp  
Cosmos Gas Detection

Dasibi Environmental Corp



1-800-765-3473

Detector Electronics Corp  
Dival Safety Equipment  
EIT  
ENMET Corp  
Electrosynthesis Co  
**Energy Efficiency Systems Inc**  
SEE AD ON PAGE 11  
Engelhard Corp  
Environmental Monitor Systems Inc  
Fisher Scientific Safety Products Div  
**Foxboro Co, The**  
SEE AD ON PAGE 46



510-745-1275

Gas Tech Inc  
General Monitors  
Hazzo Services Inc  
**Health Consultants Inc**  
SEE AD ON PAGE 142  
**Horiba Instruments Inc**  
SEE AD ON PAGE 44  
Industrial Scientific Corp  
Intek Corp/Rent-Alyzer  
International Sensor Technology  
LINC Quantum Analytics  
Lab Safety Supply  
MSA  
McNeill International  
Metrosonics Inc  
Midwesco Filter Resources Inc  
**Milco Safety Rental**  
SEE AD ON PAGE 64  
National Draeger Inc  
Neutronics  
Nova Analytical Systems Inc  
Ntron Inc, A Neutronics Co  
Response Rentals  
Rosemount Analytical Inc  
Sensidyne Inc  
Sensor Electronics Corp  
Servomex Co Inc  
Siemens Industrial Automation Inc  
Sierra Monitor Corp  
Solomat  
Spectrum Chemical & Safety Products  
Thermo Environmental Instruments  
Transducer Research

**Health Consultants Inc**

**Horiba Instruments Inc**

**Milco Safety Rental**

**SALEM ENGELHARD**

Kinane Engineering  
National Environmental Systems Inc  
Northwestern Carbon  
Professional Analytical & Consulting  
Services Inc  
Remedial Systems Inc  
Wheelabrator Environmental  
Systems Inc  
Zimpro Environmental Inc

**Cascade Impactors**

CAE Instrument Rental

**Catalysts**

**Adwest Technologies Inc**  
SEE AD ON PAGE 36  
Airex Div Adwest Technologies



918-266-1400

Allied-Signal Inc Environmental Catalysts  
American Environmental International Inc  
CSM Environmental Systems Inc  
Celite Corp  
EPG Companies Inc  
Engelhard Corp  
Grace Thermal & Emission Control  
System  
H2 Oil Recovery Equipment Inc



610-971-3100

Johnson Matthey Env  
Medina Agriculture Products Co Inc  
**Met-Pro Corp Systems Div**  
SEE AD ON PAGE 43  
Norton Chemical Process Products Corp  
Rhône-Poulenc Inc Specialty  
Chemicals Div



613-437-1400

**Salem Engelhard**  
SEE AD ON PAGE 119  
Spectrum Chemical & Safety Products  
W R Grace - Grace Emission Control

**Cathodic Protection Equipment**

Atlantic Screen & Mtg Inc  
Engelhard Corp  
Ferrick Construction Co Inc

**Centrifuges**

Bird Machine Co Inc  
Cole-Parmer Instrument Co  
Disflo Corp  
G E Co  
Hyde Products Inc  
Krebs Engineers  
Sharples, Business Unit of Alfa Laval  
Separation  
Universal Process Equipment Inc

**Chemical Information**

AE Environmental Services Inc  
CHEM-Tel Inc  
Chemical Information System  
Hazmat America Inc  
JT Baker Chemical Inc  
Lab Safety Supply  
Legible Sign Inc  
Programming Technology  
Spectrum Chemical & Safety Products  
Tedder & Widheim Consultants Inc

**Chemical Odor Control**



1-800-321-8824

NuTech Environmental Corp

**Chemical Storage Buildings**

American Safety Products Inc  
Benko Products Inc  
Containment Corp  
**Convall Inc**  
SEE AD ON PAGE 140  
EASI-SET Industries  
Environmental Container Corp  
Fisher Scientific Safety Products Div



1-800-943-6510

**Haz Mat Containment Corporation**  
SEE AD ON PAGE #

Haz-Stor Co  
Intl Hazmat Storage Div of Intl Cold  
Storage Co Inc  
Lab Safety Supply  
O'Brien & Gere Technical Services Inc  
Parkline Inc  
Plastic Fab Inc  
RFG Environmental Systems Inc  
**Safety Storage Inc**  
SEE AD ON PAGE 70  
Spectrum Chemical & Safety Products  
Ultratech International

**Chemicals**

AE Environmental Services Inc  
AccuStandard Inc  
Beckart Environmental Inc  
CORTEC Corp  
Chemical Lime Co  
Cole-Parmer Instrument Co  
Disflo Corp  
Environmental Energy Services Inc (EES)



1-800-EPOLEON

**Epoelon Corp of America**  
SEE AD ON PAGE 24

Ferro Corp, Bedford Chemical Div  
Ferro Corp, Grant Chemical Div  
Fisher Scientific Safety Products Div  
G E Co  
Green Earth Technologies Corp  
H F Scientific Inc  
Inorganic Ventures Inc  
JT Baker Chemical Inc  
Lincoln Automotive  
Martin Marietta Magnesia Specialties Inc  
Minuteman Intl Inc  
NST Engineers  
Nalco Chemical Co  
National Magnesia Chemicals  
Orbeco Analytical Systems Inc  
Red Bird Service  
Rhône-Poulenc Inc Specialty  
Chemicals Div  
Spectrum Chemical & Safety Products  
Stockhausen  
Structure Probe Inc/SPI Supplies  
Sunshine Technology Corp  
Sybron Chemicals Inc  
Taylor Technologies  
Ultra Scientific Inc

**Chillers**

Edwards Engineering  
Environmental Protection Systems  
Liebert Corp  
Measurement & Flow Control  
Neslab Instruments Inc



PACE Environmental Products  
Stanley Consultants Inc  
Structure Probe Inc/SPI Supplies  
Universal Process Equipment Inc

Varian Instruments

**Chlorination Equipment**

Bailey-Fischer & Porter Co  
Capital Controls Co Inc  
Chemineer Inc  
Chlorinators Inc  
Chlorine Specialties  
Fluidyne Corp  
Global Water  
Ionics Inc  
Jet Inc  
Luft Instruments Inc  
Mastrro Co, The  
ProMinent Fluid Controls Inc  
Purestream Inc  
Smith & Loveless Inc  
**Wallace & Tierman Inc**

**Clamps, Pipe**

**Diversified Well Products Inc**

SEE AD ON PAGE 30  
Engelhard Corp  
Environmental Industrial Resources  
Jerman Waterworks Supply  
Midwestco Filter Resources Inc  
National Bulk Equipment Inc  
Oetiker Inc/Clamping Technology

**Clarifiers**

Alar Engineering Corp  
Andco Environmental Processes Inc

**C G S**  
516-467-1600

Clean Gas Systems Inc  
Denver Mineral Engineers Inc  
Disflo Corp  
EIMCO Process Equipment Co  
Envirex  
Great Lakes Environmental Inc  
Hitachi Maxco Ltd  
Hyde Products Inc  
Hydro Group  
Industrial Filter & Pump Mfg Co  
Inn-Nova-Tech Inc  
Krebs Engineers  
Lakeside Equipment Corp  
Marshall Industrial Technologies  
**Met-Pro Corp Systems Div**

SEE AD ON PAGE 43

Monroe Environmental Corp  
Parkson Corp  
Pollution Control Inc  
Purestream Inc  
Remedial Systems Inc  
Schreiber Corp Inc  
Sharples, Business Unit of Alfa Laval  
Separation  
Smith & Loveless Inc  
Tenco Hydro Inc  
Treatment Technologies  
United States Filter Corp  
Universal Process Equipment Inc  
Water Inc  
Western Filter Co  
Wheelabrator Engineered Systems Inc -  
Mentek Products  
Zimpro Environmental Inc

**Clarifiers Drive Units**

EIMCO Process Equipment Co  
Engelhard Corp  
Hitachi Maxco Ltd  
Inn-Nova-Tech Inc  
Marshall Industrial Technologies  
Water Inc

**Clean Rooms/Supplies**

AAF International  
Cole-Parmer Instrument Co  
Dival Safety Equipment  
Fisher Scientific Safety Products Div  
G E Co  
Inflatable Abatement Systems Inc  
Lab Safety Supply  
Liebert Corp  
Measurement & Flow Control  
Minuteman Intl Inc  
Neslab Instruments Inc  
Nuarec Inc  
O'Brien & Gere Technical Services Inc  
Porta-Fab Corp  
Raytheon Engineers &  
Constructor/Raytheon Enviro Svc  
Spectronics Corp  
Spectrum Chemical & Safety Products  
Starco Co Inc

**Terra Universal, Inc.**  
Contaminants Control Equipment  
714-526-0100

Terra Universal  
United McGill Corp  
W L Gore & Associates Inc

**Cleaning Equipment/Supplies**

Abar Ipsen Industries  
Advance Machine Co  
Cole-Parmer Instrument Co  
DeMarco MAX VAC Corp  
ESCA Tech Inc  
Georgia Steel & Chemical  
Gojo Industries Inc  
Goodway Technologies Corp  
Gran-Tenescos Resources Inc  
Gurman Container & Supply Corp  
Highland Tank  
Hill Manufacturing Co Inc  
Integrated Chemistries Inc  
Lab Safety Supply  
Landa Inc  
Liquid Carbonic  
Mole Master Services Corp  
**New Pig Corp**

SEE AD ON PAGE 138

Nitfisk of America Inc  
Pentek Inc  
Plainsol  
RMJ Machinery Inc  
Spectrum Chemical & Safety Products  
Spraying Systems Co  
Vac-U-Max

**Cleaning/Flushing Services**

ARD Environmental Inc  
**Carylon Corp**  
SEE AD ON PAGE 66  
Ferrick Construction Co Inc  
Mole Master Services Corp  
Northeast Environmental Services

**Clothing, Protective**

Ben Meadows  
Chem-Tex Corp  
Chemfab Corp  
Direct Safety Co  
Dival Safety Equipment  
Engelhard Corp  
Environmental Products & Services Inc  
Fisher Scientific Safety Products Div  
Gurman Container & Supply Corp  
Hazo Services Inc  
ILC Dover Inc  
Kappler  
Lab Safety Supply  
Labelmaster  
MSA  
Magid Glove & Safety Mfg Co  
Midwestco Filter Resources Inc  
Spectrum Chemical & Safety Products  
Steele Inc  
Terra Universal

**Coagulation**

Colloid Environmental Technologies Co  
Fluidyne Corp  
Stockhausen  
Western Filter Co

**Coatings/Linings**

Abresist Corp  
Advanced Polymer Sciences Inc

**Ampul** 501-235-7297  
American Fuel Cell and Coated Fabrics Company

Ampul  
CORTEC Corp

Dampney Co Inc  
Ferro Corp, Frit Div  
Ferro Corp, Liquid Coatings & Dispersion  
Div/Indiana  
Gelok Intl Corp  
Gundie Lining Systems Inc  
Koch Engineering Co Inc  
Labelmaster

Fisher Scientific Safety Products Div

**GAT-CH**  
510-745-1275

Gas Tech Inc  
General Motors  
Grace Industries Inc  
H2 Oil Recovery Equipment Inc  
HNU Systems Inc  
Hazo Services Inc  
**Heath Consultants Inc**

SEE AD ON PAGE 142

Industrial Scientific Corp  
Intek Corp/Rent-Alyzer  
Inertional Sensor Technology  
Jerman Waterworks Supply  
LINC Quantum Analytics  
MSA

McNeill International  
Metrotronics Inc  
Midwestco Filter Resources Inc  
**Milco Safety Rental**

SEE AD ON PAGE 64

National Draeger Inc  
Neutronics

**Photovac Monitoring Instruments**

SEE AD ON PAGE 42

R E Wright Associates Inc (REWII)  
Response Rentals  
Rosemount Analytical Inc  
Scott Aviation, A Figgie Intl Co  
Sensidyne Inc  
Sensor Electronics Corp  
Servomex Co Inc  
Sierra Monitor Corp  
Solomat  
Spectrum Chemical & Safety Products  
Teledyne Brown Engineering/Analytical  
Instruments  
Universal Enterprises Inc

**Combustion Control Instruments**

Air Instruments & Measurements Inc  
Air Monitor Corp  
Automation Products Inc  
Bacharach Inc  
Bailey Controls Co  
Climatronics Corp  
Columbia Scientific  
Datatest Corp  
Ecom America Ltd  
Hazo Services Inc  
NAO Inc  
Nova Analytical Systems Inc  
**Omega Engineering Inc**  
SEE AD ON PAGE 2  
Rosemount Analytical Inc

**Communication Equipment**

Advanced Control Systems  
Climatronics Corp  
Columbia Science Industries Co  
Dancer Communications Inc  
Dival Safety Equipment  
**Environmental Restoration Systems Inc**  
SEE AD ON PAGE 18

G E Co  
Hazo Services Inc  
MSA  
Norris Technologies Inc  
Phonetics Inc

**Comminutors/Grinders**

Enviro Care  
Glen Mills Inc  
Inn-Nova-Tech Inc  
JWC Environmental  
Marshall Industrial Technologies  
Purestream Inc

**DET TRONICS**  
1-800-765-3473

Detector Electronics Corp  
Dival Safety Equipment  
EIT  
ENMET Corp  
Environmental Technologies Group  
H F Scientific Inc  
Hazo Services Inc  
Industrial Scientific Corp  
International Sensor Technology  
MSA  
Metrotronics Inc  
National Draeger Inc  
Nova Analytical Systems Inc  
**Omega Engineering Inc**  
SEE AD ON PAGE 2  
Orbeco Analytical Systems Inc  
ProMinent Fluid Controls Inc  
SWAN/Industries Analytics  
Scott Aviation, A Figgie Intl Co  
Sensidyne Inc  
Sensor Electronics Corp  
Servomex Co Inc  
Sierra Monitor Corp  
Spectrum Chemical & Safety Products  
Stranco Inc  
**Wallace & Tierman Inc**  
SEE AD ON PAGE 29

**Chromatographs**

American Scientific Instrumentation  
Bacharach Inc  
Celite Corp  
Cole-Parmer Instrument Co  
E S Industries  
ES Industries  
HNU Systems Inc  
Hazo Services Inc  
**Heath Consultants Inc**  
SEE AD ON PAGE 142  
Intek Corp/Rent-Alyzer  
LINC Quantum Analytics  
OI Analytical  
Perkin-Elmer Corp  
SRI Instruments  
Sensidyne Inc

**Morton**  
312-807-3108

Morton International Inc  
Plastic Fusion Fabricators  
Polyspec Corp  
Rhône-Poulenc Inc Specialty Chemicals  
Div  
Sauerseisen

**Sentry**  
POLYMERS, INC  
409-233-0312

Sentry Polymers Inc  
Tank Industry Consultants Inc  
Tnemecc Co Inc  
Wisconsin Protective Coat

**COD Instrumentation**

Anatel Corp  
Bioscience Inc  
CHEMetrics Inc

**HACH**  
800-227-4224

Hach Co  
Orbeco Analytical Systems Inc

**Colorimeters**

Ametek Inc  
Bacharach Inc  
Ben Meadows  
CHEMetrics Inc  
H F Scientific Inc  
Hazo Services Inc  
Hellma  
**Omega Engineering Inc**  
SEE AD ON PAGE 2  
Orbeco Analytical Systems Inc  
Petrolab Corp  
Wilkins-Anderson Co

**Combustible Gas Detectors**

AIM Safety USA Inc  
Bacharach Inc  
Bailey Controls Co  
Bascom-Turner Instruments  
Biosystems  
CEA Instruments  
Cole-Parmer Instrument Co

**Control Instruments Corporation**  
201-575-9114

Control Instruments Corp  
Cosmos Gas Detection  
Datatest Corp

**DET TRONICS**  
1-800-765-3473

Detector Electronics Corp  
Dival Safety Equipment  
EIT  
ENMET Corp  
EPG Companies Inc  
Engelhard Corp  
Environmental Monitor Systems Inc  
Environmental Products & Services Inc

Water Inc  
Wysmont

**Compactors**

Accurate Industries  
Benko Products Inc  
Bes-Pac Inc  
Caron Compactor Co  
Compacting Technologies  
Eager Beaver Recycling Equipment  
Environmental Compaction Inc  
G E Co  
Galbreath Inc  
Glen Mills Inc  
Gurman Container & Supply Corp  
J V Mfg Inc/Cram-A-Lot  
Marathon Equipment Co  
Marshall Industrial Technologies  
National Recycling Equipment Co  
**New Pig Corp**  
SEE AD ON PAGE 138

Piqua Waste Equipment Inc  
RMJ Machinery Inc  
S & G Enterprises Inc  
SSI Shredding Systems Inc  
Sebright Products Inc  
Youngstown Barrel & Drum Co

**Composting Systems**

Airdomes Inc  
Amadas Industries  
Ellicott Engineering Inc  
Kinane Engineering  
Multitek Inc  
**Omega Engineering Inc**  
SEE AD ON PAGE 2  
Plastic Fab Inc  
Portec Construction Equip Div  
Sewall, James W Co  
Spectraserv

**Compressors**

Air Dimensions Inc



**BVS** 610-273-2841

BVS Inc  
Ben Meadows  
Blakmer Pump/DVR Res  
Brailsford & Company  
EPG Companies Inc  
Eagle Compressors  
**Environmental Restoration Systems Inc**  
SEE AD ON PAGE 18  
Free Flow Inc  
Gardner Denver Machinery Inc  
Gast Manufacturing Corp



**FLOW GEMINI**  
1-800-934-5917

General Research Corp  
Hazo Services Inc  
Marshall Industrial Technologies  
Measurement & Flow Control  
Roots Div/Dresser Industries  
Sutorbit/Duroflow/Gardner Denver  
TIMCO Mfg Inc

**Computer Control**

ANVIC Controls  
Anderson 2000 Inc  
Bailey-Fischer & Porter Co  
Bristol Babcock Inc  
EPG Companies Inc  
**Environmental Restoration Systems Inc**  
SEE AD ON PAGE 18



**H&NS Environmental Inc**  
512-918-8035

H2NS Environmental  
Hans Environmental Inc  
Intec Controls Corp  
Marshall Industrial Technologies  
Norris Technologies Inc  
**Omega Engineering Inc**  
SEE AD ON PAGE 2  
Perkin-Elmer Corp  
R E Wright Associates Inc (REWI)  
Trilogy Controls Inc

**Computer Databases**



**AV systems** 313-973-3000

A V Systems Inc  
AE Environmental Services Inc  
Agency Information Consultants Inc (AIC)  
Bailey-Fischer & Porter Co  
CHEM-Tel Inc  
Chemical Information System  
Cochrane Associates Inc



**COMPUTER ALLI**  
1-800-844-1400

**Computer Allii**  
SEE AD ON PAGE 120  
Corbus A Div of CMS Inc  
Corporation for Environmental Management  
**Counterpoint Publishing**  
SEE AD ON PAGE 14  
EA Engineering, Science & Technology Inc  
EcoAnalysis Inc  
EnviroBase Systems Inc  
Fast Search Corp

General Research Corp  
General Sciences Corp  
Genium Publishing Corp  
Geotrans Inc



**H&NS Environmental Inc**  
512-918-8035

H2NS Environmental  
Hans Environmental Inc  
Hazmat America Inc  
Heart Information Systems Inc  
J J Keller & Associates Inc  
**Logical Technology Inc**  
SEE AD ON PAGE 138  
Marshall Industrial Technologies  
Pro-Am Software  
Programming Technology  
Sonoma Technology Inc  
StratFact Software  
Waid & Associates  
**Williams Knowledge Systems Inc**  
SEE AD ON PAGE 9

**Computer Devices**

Cochrane Associates Inc



**COMPUTER ALLI**  
1-800-844-1400

**Computer Allii**  
SEE AD ON PAGE 120  
Environmental Monitor Systems Inc



**FLOW GEMINI**  
1-800-934-5917

General Research Corp

**Computer Modeling (Air, Groundwater, Hazard & Risk)**

AE Environmental Services Inc  
AWD Technologies Inc  
Adirondack Environmental Associates Inc  
Air Resource Specialists Inc  
Air Science Consultants



**AMS**  
1-800-635-7330

**Art's Manufacturing & Supply (AMS)**  
SEE AD ON PAGE 53

Arthur D Little Inc  
BEM Systems Inc  
Barr Engineering Co  
Blasland Bouck & Lee Inc  
Bowman Environmental Engineering Inc  
Braun Intertec Corp  
Brown & Root Environmental  
Burns & McDonnell  
CET Environmental Services Inc  
Center for Hazardous Materials Research  
Climatronics Corp  
Computational Mechanic Corporation for Environmental Management  
DNV Technica Inc  
Dames & Moore  
EA Engineering, Science & Technology Inc  
ERM Group, The  
ERM-South Inc  
Engineering Software  
Environmental Standards Inc  
Environmental Technologies Group  
FBA Environmental Inc  
Foster Wheeler Environmental Corp  
G A Huber Co  
Galson Corp  
Gannett Fleming Inc



**FLOW GEMINI**  
1-800-934-5917

General Research Corp  
General Sciences Corp  
GeoSyntec Consultants  
Geotrans Inc  
Golden Software Inc  
H H Burkitt Project Management Inc  
Haestad Methods  
Hart Crowser Inc  
Hazmat America Inc  
Integrph Corp  
Kennedy/Jenks Consultants  
L Robert Kimball & Associates  
Morrison, Knudsen Corp  
Ogden Environmental & Energy Services  
**Omega Engineering Inc**  
SEE AD ON PAGE 2  
Oxford Environmental Inc  
Parsons Engineering Science Inc  
R E Wright Associates Inc (REWI)  
Radian Corp  
Raytheon Engineers & Constructor/Raytheon Enviro Svc  
Rust Environment & Infrastructure  
Rust International Inc  
Sonoma Technology Inc  
Stanley Consultants Inc  
StratFact Software  
Sverdrup Environmental Inc  
Traverse Group, The  
Trinity Consultants Inc  
Waid & Associates

Walk, Haydel & Associates Inc  
**Computer Software, Chemical Database**



**AV systems** 313-973-3000

A V Systems Inc

**Computer Software, Management**



**AV systems** 313-973-3000

A V Systems Inc  
ADS Environmental Services Inc  
AE Environmental Services Inc  
**Achieve! Technology Inc**  
SEE AD ON PAGE 139



**TINA** 415-726-5700

Alternative Systems Inc  
Cochrane Associates Inc



**COMPUTER ALLI**  
1-800-844-1400

**Computer Allii**  
SEE AD ON PAGE 120  
Construction Link Inc, The  
Corbus A Div of CMS Inc  
**Counterpoint Publishing**  
SEE AD ON PAGE 14  
Datastream Systems Inc  
ERM Group, The  
EcoAnalysis Inc  
Envires Corp  
EnviroBase Systems Inc  
Environmental Compliance Systems Corp  
Environmental Monitor Systems Inc  
Environmental Resource Center



**FLOW GEMINI**  
1-800-934-5917

General Research Corp  
General Sciences Corp  
Genium Publishing Corp  
Geotrans Inc  
HazWaste Technologies Corp  
Hazo Services Inc  
Heart Information Systems Inc  
Ibex Technologies  
Intec Controls Corp  
Integrph Corp  
Kaye Instruments Inc  
Labelmaster  
**Logical Technology Inc**  
SEE AD ON PAGE 138  
Medina Agriculture Products Co Inc  
Octstar Inc  
**Omega Engineering Inc**  
SEE AD ON PAGE 2  
Perkin-Elmer Corp  
Professional Analytical & Consulting Services Inc  
Programming Technology  
Resource Consultants Inc CHEMTOX Div

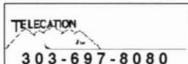

**TELECOM**  
303-697-8080

Telecom Inc  
Utlicom Inc  
Waid & Associates

**Computer Software, Management (MSDS)**



**CORBUS**  
A Division of  
Compliance Management Systems, Inc.  
1-800-524-7096

Corbus A Div of CMS Inc

**Computer Software, Regulatory**



**AV systems** 313-973-3000

A V Systems Inc

**Achieve! Technology Inc**  
SEE AD ON PAGE 139



**TINA** 415-726-5700

Alternative Systems Inc  
American Scientific Instrumentation  
Bowman Environmental Engineering Inc  
Climatronics Corp  
Cochrane Associates Inc  
Compliance Management Systems



**COMPUTER ALLI**  
1-800-844-1400

**Computer Allii**  
SEE AD ON PAGE 120



**CORBUS**  
A Division of  
Compliance Management Systems, Inc.  
1-800-524-7096

Corbus A Div of CMS Inc  
**Counterpoint Publishing**  
SEE AD ON PAGE 14  
Datastream Systems Inc  
ERM Group, The  
EcoAnalysis Inc  
Envires Corp  
EnviroBase Systems Inc  
Environmental Compliance Systems Corp  
Environmental Resource Center  
Enviroplan Inc  
Fast Search Corp  
Galson Corp



**FLOW GEMINI**  
1-800-934-5917

General Research Corp  
General Sciences Corp  
Genium Publishing Corp



**H&NS Environmental Inc**  
512-918-8035

H2NS Environmental  
Hans Environmental Inc  
HazWaste Technologies Corp  
Heart Information Systems Inc  
**IHS Regulatory Products**  
SEE AD ON PAGE 25  
Intec Controls Corp  
J J Keller & Associates Inc  
Labelmaster



**LOGICAL TECHNOLOGY INC**  
1-800-COMPLY1

**Logical Technology Inc**  
SEE AD ON PAGE 138  
Octstar Inc  
**Omega Engineering Inc**  
SEE AD ON PAGE 2

Primatech Inc  
Pro-Am Software  
Professional Analytical & Consulting Services Inc  
Programming Technology  
Regulation Scanning  
Resource Consultants Inc CHEMTOX Div

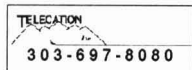

Telecon Inc  
Trinity Consultants Inc  
Utilicom Inc  
Waid & Associates



Williams Knowledge Systems Inc  
SEE AD ON PAGE 9

**Computer Software, SARA Reporting**



Corbus A Div of CMS Inc

**Computer Software, Training**



A V Systems Inc  
Achieve! Technology Inc  
SEE AD ON PAGE 139  
Bowman Environmental Engineering Inc



Computer Allii  
SEE AD ON PAGE 120  
Corbus A Div of CMS Inc  
Datastream Systems Inc  
Environmental Resource Center  
Galaxy Environmental Corp



General Research Corp  
General Sciences Corp  
Genium Publishing Corp  
J + W Scientific  
J J Keller & Associates Inc  
Lab Safety Supply  
Labelmaster  
Pro-Am Software  
Professional Analytical & Consulting Services Inc  
Summit Training Source



Williams Knowledge Systems Inc  
SEE AD ON PAGE 9

**Concentrators**



Durr Industries Inc  
Entech Instruments  
Finning/Tremetrics  
LINC Quantum Analytics  
OI Analytical  
Perkin-Elmer Corp  
Pope Scientific  
Price-Darnall Inc of Alabama  
Resources Conservation Co  
Salem Engelhard  
SEE AD ON PAGE 119  
Soil & Material Engineers Inc  
Spectrum Medical Industries



Swenson Process Equipment Inc  
Telkamp Systems Inc

**Conductivity Instrumentation**

ATI Orion  
Bailey Controls Co  
Ben Meadows  
Campbell Scientific Inc  
Capital Controls Co Inc  
Cole-Parmer Instrument Co  
Colog Inc  
SEE AD ON PAGE 32

ELE International Inc/Soiltest Products Div  
G O Environment Inc  
Geoguard Inc  
George Fischer Inc



Hach Co  
Hazco Services Inc  
Horiba Instruments Inc  
SEE AD ON PAGE 44  
HydroLab Corp  
SEE AD ON PAGE 22  
Intek Corp/Rent-Alyzer

LINC Quantum Analytics  
Lab-Line Instruments Inc  
Marshall Industrial Technologies  
Myron L Co

**Omega Engineering Inc**  
SEE AD ON PAGE 2

Orbeco Analytical Systems Inc  
Perkin-Elmer Corp  
ProMent Fluid Controls Inc  
Progressive Equipment Corp  
Response Rentals  
Schneider Instrument Co  
Serflico Ltd  
Solomat  
Taylor Technologies  
Thornton Associates Inc  
Unidata America  
YSI Inc

**Consulting Services**

A M A R C Inc (AIHMM)  
ABB Environmental Services Inc  
ACRT Inc Environmental Specialist  
ADS Environmental Services Inc  
AE Environmental Services Inc  
AIG Consultants Inc  
ARD Environmental Inc  
ASTB/Analytical Services Inc  
ATEC Associates Inc  
ATI  
AWD Technologies Inc

Admiral Environmental Services Inc  
Air Resource Specialists Inc  
Air Science Consultants  
Alton Geoscience  
Ambient Engineering Inc  
American Scientific Instrumentation  
American Standards Testing Bureau Inc  
Angvine Acoustical Consultants Inc  
Applied Science & Technology Inc  
AquaTec Inc  
Arthur D Little Inc  
BEM Systems Inc  
Barr Engineering Co  
Beardsley, Brown & Bassett Inc  
Blasland Bouck & Lee Inc  
Book Environmental Service Inc  
Braun Intertec Corp  
Brown & Root Environmental  
Burns & McDonnell  
Carylon Corp  
SEE AD ON PAGE 66



COMCO Inc  
Carnow, Conibear & Associates Ltd  
Center for Hazardous Materials Research  
ChemCycle Corp  
Chester Environmental  
Clean Air Engineering  
Cochrane Associates Inc  
Colog Inc  
SEE AD ON PAGE 32

Commercial Dexterity  
SEE AD ON PAGE 64  
Compliance Mgmt Assoc  
Consulting Environmental Engineers Inc  
Container Testing Laboratory Inc  
Corbus A Div of CMS Inc  
Corporation for Environmental Management  
Covino Environmental Consulting Inc  
Dames & Moore  
Datastream Systems Inc  
Detail Associates Inc  
Dixon Environmental Associates Inc  
Ducon Environmental Systems Inc

SEE AD ON PAGE 32  
SEE AD ON PAGE 64

Compliance Mgmt Assoc  
Consulting Environmental Engineers Inc  
Container Testing Laboratory Inc  
Corbus A Div of CMS Inc  
Corporation for Environmental Management  
Covino Environmental Consulting Inc  
Dames & Moore  
Datastream Systems Inc  
Detail Associates Inc  
Dixon Environmental Associates Inc  
Ducon Environmental Systems Inc



Durr Industries Inc  
EA Engineering, Science & Technology Inc  
ECOSTAT Inc  
ELB & Associates  
ENSCI Environmental Inc  
ERM Group, The  
ERIM-South Inc  
Eastern Technical Associates  
Electrosynthesis Co  
Enercon Services Inc  
Enviro-Systems Inc  
EnviroBase Systems Inc  
Envirogen Inc  
Environex  
Environmental Health & Engineering Inc  
Environmental Products & Services Inc  
Environmental Resource Center  
Environmental Standards Inc  
Enviroplan Inc  
Ergo-Medical Inc  
Ferrick Construction Co Inc  
Foppe Thelen Group Inc  
Foster Wheeler Environmental Corp  
Foth & Van Dyke  
G A Huber Co  
Gascoyne Laboratories Inc  
Geo-Technology Associates Inc

GeoSynTec Consultants  
Geotrans Inc  
Geraghty & Miller Inc A Heidemij Co  
Graef Anhalt Schloemer  
GrassRoots Marketing Inc  
Grossman, Walter B Assoc  
Groundwater Technology Inc  
H & H Pump & Dredge  
H H Burkitt Project Management Inc  
HDR Engineering Inc  
Haley & Aldrich Inc  
Hart Crowser Inc  
Haz Mat Containment Corporation  
HazWaste Technologies Corp  
Hazen & Sawyer  
Hazmat America Inc  
Heath Consultants Inc  
SEE AD ON PAGE 142

Heritage Environmental Services Inc  
Hill International Inc  
Hubbell, Roth & Clark Inc  
Hunter Inc, Environmental Science  
Inorganic Ventures Inc  
International Engineers Inc  
International Technology Corp  
J L A Engineering Inc  
Jaca Corp  
Jackson, R L Consulting  
Keating Environmental Management Inc  
Kennedy/Jenks Consultants  
Kinane Engineering  
L Robert Kimball & Associates  
LEXICON Environmental Associates Inc  
Lindmark Engineering Inc  
Lockwood Greene Engineers Inc  
MMT Environmental Services Inc

Mabbett & Associates Inc  
Morrison, Knudsen Corp  
NST Engineers  
National Air Transportation Association  
National Technical Systems Inc  
SEE AD ON PAGE 17  
Normandseau Associates, RMC  
Environmental Services Div  
Noxso Corp  
Occupational Health & Hygiene Corp of America  
Ogden Environmental & Energy Services  
Oxford Environmental Inc  
Parsons Engineering Science Inc  
Primatech Inc  
Professional Analytical & Consulting Services Inc  
Programming Technology  
R E Wright Associates Inc (REW)  
RMT Inc  
Radian Corp  
Raytheon Engineers & Constructor/Raytheon Enviro Sv  
Resource Consultants Inc  
Rollins Environmental  
Rust Environment & Infrastructure  
Rust International Inc  
SSM/Spotts Stevens & McCoy Inc  
Serengeti Environmental  
Sewall, James W Co  
Smith & Loveless Inc  
Sonoma Technology Inc  
Spectraserv  
Stanley Consultants Inc  
Structure Probe Inc/SPI Supplies  
Sverdrup Environmental Inc  
TRAK Environmental Group Inc  
Tank Industry Consultants Inc  
Technotreat Corp  
Tedder & Widhelm Consultants Inc  
Terra Bio Chem Environmental & Engineering Services Inc



Mabbett & Associates Inc  
Morrison, Knudsen Corp  
NST Engineers  
National Air Transportation Association  
National Technical Systems Inc  
SEE AD ON PAGE 17  
Normandseau Associates, RMC  
Environmental Services Div  
Noxso Corp  
Occupational Health & Hygiene Corp of America  
Ogden Environmental & Energy Services  
Oxford Environmental Inc  
Parsons Engineering Science Inc  
Primatech Inc  
Professional Analytical & Consulting Services Inc  
Programming Technology  
R E Wright Associates Inc (REW)  
RMT Inc  
Radian Corp  
Raytheon Engineers & Constructor/Raytheon Enviro Sv  
Resource Consultants Inc  
Rollins Environmental  
Rust Environment & Infrastructure  
Rust International Inc  
SSM/Spotts Stevens & McCoy Inc  
Serengeti Environmental  
Sewall, James W Co  
Smith & Loveless Inc  
Sonoma Technology Inc  
Spectraserv  
Stanley Consultants Inc  
Structure Probe Inc/SPI Supplies  
Sverdrup Environmental Inc  
TRAK Environmental Group Inc  
Tank Industry Consultants Inc  
Technotreat Corp  
Tedder & Widhelm Consultants Inc  
Terra Bio Chem Environmental & Engineering Services Inc

**Controllers**

AE Environmental Services Inc  
Advanced Control Systems  
Bailey Controls Co  
Bailey-Fischer & Porter Co  
Barnart Co  
Boston Gear  
CTL Environmental Services  
Carbonair Environmental Systems  
Cole-Parmer Instrument Co  
**Diversified Well Products Inc**  
SEE AD ON PAGE 30  
Durr Industries Inc  
Fluid Components Intl  
Free Flow Inc  
G E Co  
George Fischer Inc  
H2 Oil Recovery Equipment Inc  
Hazco Services Inc  
Hersey & Measurement  
Inventron Inc  
Limitrque  
Luft Instruments Inc  
Mabbett & Associates Inc

**Terra Consulting Group**  
SEE AD ON PAGE 35, 36  
Transport Law Research Inc  
Traverse Group, The  
Trinity Consultants Inc  
United Environmental Coverage Corp  
Vamco Engineering Group  
Waid & Associates  
Walk, Haydel & Associates Inc  
Yellow Logistics Services Inc

**Contracting Services**

AE Environmental Services Inc  
ARD Environmental Inc  
ATI  
AWD Technologies Inc  
Alton Geoscience  
Burns & McDonnell  
Durr Industries Inc  
ENSCI Environmental Inc  
Enviro-Sciences Inc  
Environmental Health & Engineering Inc  
Environmental Products & Services Inc  
FBA Environmental Inc  
Ferrick Construction Co Inc  
Foster Wheeler Environmental Corp  
Geraghty & Miller Inc A Heidemij Co  
Groundwater Technology Inc  
H E S Inc  
Hart Crowser Inc  
Hayward Baker Environmental  
**Heath Consultants Inc**  
SEE AD ON PAGE 142

Hydro-Terra Inc  
Keating Environmental Management Inc  
LEXICON Environmental Associates Inc  
Marshall Industrial Technologies  
Midwestco Filter Resources Inc  
Mole Master Services Corp  
**National Technical Systems Inc**  
SEE AD ON PAGE 17  
Northeast Environmental Services  
O'Brien & Gere Technical Services Inc  
Ogden Environmental & Energy Services  
Professional Analytical & Consulting Services Inc  
Programming Technology  
R E Wright Associates Inc (REW)  
Raytheon Engineers & Constructor/Raytheon Enviro Sv



Swenson Environmental Services Inc  
Smith & Loveless Inc  
Spectraserv  
Sverdrup Environmental Inc  
TRAK Environmental Group Inc

Moran Manufacturing Inc  
Newport Electronics Inc  
Norris Technologies Inc  
Omega Engineering Inc

SEE AD ON PAGE 2



**OZONAIR INTERNATIONAL CORP**  
415-952-9904

Ozonair Intl Corp  
Phonetics Inc  
Reliance Electric Co  
Remco Engineering  
Rhombus Technology  
S J Electro Systems Inc  
SWANIndustries Analytics  
Sierra Monitor Corp  
Simpson Electric Co  
Sixmet  
Susquehanna Valley Systems Inc (SVS)  
Thornton Associates Inc  
Time Applications & Electronics  
Time Mark Corp  
Trilogy Controls Inc

**Conveyors**

ABB Raymond  
Ameri-Shred Corp



**Cedarapids**  
A Raytheon Company  
319-363-3511

Cedarapids Inc A Raytheon Co



**DÜRR**  
313-459-6800

Durr Industries Inc  
Enviro Care  
Feco Engineered Systems Inc  
Frontier Technology Inc  
General Kinematics Corp  
Hyde Products Inc  
Kinane Engineering  
Marshall Industrial Technologies  
National Bulk Equipment Inc  
Portec Construction Equip Div  
Production Systems Inc  
Reliance Electric Co  
Serpentix Conveyor Corp  
Universal Process Equipment Inc  
Vac-U-Max  
Vibra Screw Inc

**Cooling Tower Water**

Andco Environmental Processes Inc  
CHEMetrics Inc  
Capital Controls Co Inc  
Environmental Protection Systems  
Keoco R & D Inc  
MIOX Corp  
Nalco Chemical Co  
Neslab Instruments Inc



**OZONAIR INTERNATIONAL CORP**  
415-952-9904

Ozonair Intl Corp  
Progressive Equipment Corp  
Spectraserv  
Water Equipment Tech  
Wheelabrator Environmental  
Systems Inc

**Cooling Towers**

ARD Environmental Inc  
Chlorinators Inc



**CGS**  
516-467-1600

Clean Gas Systems Inc  
Climatronics Corp  
Delta Cooling Towers Inc  
SEE AD ON PAGE 62  
Environmental Protection Systems  
Neslab Instruments Inc  
Niro Inc

SEE AD ON PAGE 51  
O'Brien & Gere Technical Services Inc  
Progressive Equipment Corp  
Raytheon Engineers &  
Constructor/Raytheon Enviro SVc  
Soil & Material Engineers Inc  
Spraying Systems Co  
United McGill Corp  
Universal Process Equipment Inc  
Wheelabrator Environmental  
Systems Inc

**Core Sampler**

Alliance Environmental Inc



**AMS**  
1-800-635-7330

Art's Manufacturing & Supply (AMS)  
SEE AD ON PAGE 53  
Associated Design & Mfg  
Ben Meadows  
Clemons Associates Inc

SEE AD ON PAGE #

Dival Safety Equipment  
Diversified Well Products Inc  
SEE AD ON PAGE 30  
ELE International Inc/Soiltest  
Products Div  
Hazzo Systems Inc  
Wonder Makers Inc

**Corrosion Instrumentation/Protection**

American EnviroSpect Inc  
Atlas Minerals & Chemicals Inc  
CHEMetrics Inc  
Engelhard Corp  
Nalco Chemical Co  
Petrolab Corp

**Couplings**

Atlantic Screen & Mfg Inc  
Boston Gear  
Civacon-Dover Resources  
Dodge/Reliance Electric  
Environmental Industrial Resources  
Guardian Industries



**MMC**  
1-800-645-7339

MMC Intl Corp  
SEE AD ON PAGE 23  
National Bulk Equipment Inc  
Naylor Pipe Co  
Parker Hamflin Corp  
SEE AD ON PAGE 144  
Reliance Electric Co  
Swagelok Companies, The

**Covers/Domes**

Brown Minneapolis Tank  
Conservatek Industries Inc  
Gundie Lining Systems Inc  
JPS Elastomers Corp  
Reef Industries Inc  
Skolnik Industries Inc  
Temcor

**Crushers**

American Pulverizer Co  
Benko Products Inc



**Cedarapids**  
A Raytheon Company  
319-363-3511

Cedarapids Inc A Raytheon Co  
Environmental Compaction Inc  
G E Co  
Glen Mills Inc  
Gurman Container & Supply Corp  
Hyde Products Inc  
LaBounty Manufacturing Div of Stanley  
Hydraulic Tools  
MAC Corp/Saturn Shredders  
Portec Construction Equip Div  
RMJ Machinery Inc  
S & G Enterprises Inc  
Universal Engineering  
Universal Process Equipment Inc  
Wyssmont  
Youngstown Barrel & Drum Co

**Cyclones**

Abresist Corp  
Aget Manufacturing Co  
Airotech



**Cedarapids**  
A Raytheon Company  
319-363-3511

Cedarapids Inc A Raytheon Co



**CGS**  
516-467-1600

Clean Gas Systems Inc  
College Research Corp (CORECO)  
Ducon Environmental Systems Inc  
Dustvent Inc  
G E Co  
Hudson Industries  
Krebs Engineers  
Morlan & Morlan Inc  
Stanley Consultants Inc  
Turner EnviroLogic Inc  
Vacuum Engineering  
Vector Technologies Ltd

**Dampers**

Air Plastics Inc  
Breslove Separator Co Inc  
Kalair Products Inc  
Midwesco Filter Resources Inc  
Turner EnviroLogic Inc  
United McGill Corp

**Data Acquisition Equipment**

Acromag Inc  
Advanced Control Systems  
Anarad Inc  
Bailey-Fischer & Porter Co  
Bristol Babcock Inc  
CAE Instrument Rental  
Campbell Scientific Inc  
Cole-Parmer Instrument Co  
Colog Inc

SEE AD ON PAGE 32

Dancer Communications Inc  
Dasibi Environmental Corp  
Dianachart Inc  
Dwyer Instruments Inc  
ELE International Inc/Soiltest  
Products Div  
EPG Companies Inc  
Earth & Atmospheric Sciences Inc  
Eastern Technical Associates  
Environmental Monitor Systems Inc  
**Environmental Restoration**

**Systems Inc**

SEE AD ON PAGE 18

Enviroplan Inc  
Extach Instruments  
G E Co  
G O Environment Inc  
Global Water



**H&NS Environmental Inc**  
512-918-8035

H2NS Environmental  
Handar  
Hans Environmental Inc  
Hazzo Services Inc  
Hull Corp Environmental Products Div  
**HydroLab Corp**

SEE AD ON PAGE 22

Intek Corp/Rent-Alyzer  
Inverton Inc  
Kaye Instruments Inc  
Keithley-Metrabyte  
Kipp & Zonen

**Met-One Instruments Inc**

SEE AD ON PAGE 26

Metrosonics Inc  
Monarch Instrument  
National Instruments  
Newport Electronics Inc  
Norris Technologies Inc  
NovaLynx Corp

**Omega Engineering Inc**

SEE AD ON PAGE 2

PACE Environmental Products  
Perkin-Elmer Corp  
Phonetics Inc  
Qualimetrics Inc  
Remedial Systems Inc  
SRI Instruments  
Schneider Instrument Co  
Sierra Monitor Corp  
Sixnet  
Solomat  
Soltec Corp  
Sonoma Technology Inc  
Teledyne Brown Engineering - Control  
Applications  
Telog Instruments Inc  
**Vertek**

SEE AD ON PAGE 61

**Data Loggers**

A I W Inc  
A P Buck Inc  
Acromag Inc  
Ben Meadows  
CAE Instrument Rental  
Campbell Scientific Inc  
Climatronics Corp  
Coastal Environmental Systems  
Coastal Leasing Inc  
Cochrane Associates Inc  
Cole-Parmer Instrument Co  
**Colog Inc**

SEE AD ON PAGE 32

Dancer Communications Inc  
Dasibi Environmental Corp  
Dianachart Inc  
**Diversified Well Products Inc**

SEE AD ON PAGE 30

ELE International Inc/Soiltest  
Products Div  
EPG Companies Inc  
Earth & Atmospheric Sciences Inc  
Eastern Technical Associates  
Environmental Products & Services Inc  
Fisher Scientific Safety Products Div  
**Foxboro Co, The**

SEE AD ON PAGE 46

G O Environment Inc  
Geoguard Inc  
Global Water



**H&NS Environmental Inc**  
512-918-8035

H2NS Environmental  
Handar  
Hans Environmental Inc  
Hazzo Services Inc



**In-Situ Inc**  
The Solutions People  
1-800-446-7488

In-Situ Inc  
Instruments Direct Inc  
Intek Corp/Rent-Alyzer  
Kaye Instruments Inc  
LINC Quantum Analytics

**Met-One Instruments Inc**

SEE AD ON PAGE 26

Metrosonics Inc  
Monarch Instrument  
Monitor Labs Inc  
Norris Technologies Inc  
NovaLynx Corp

**Omega Engineering Inc**

SEE AD ON PAGE 2

PACE Environmental Products  
Qualimetrics Inc  
R E Wright Associates Inc (REWI)  
Response Rentals  
Sewall, James W Co  
Solomat  
Soltec Corp  
Sonoma Technology Inc



**telog**  
716-359-1110

Telog Instruments Inc  
Thornton Associates Inc  
Unidata America  
Wavelek Corp

**Deaerators/Degasifiers**

Bryan Steam Corp  
Smith & Loveless Inc  
United States Filter Corp

**Dechlorination Equipment**

Bailey-Fischer & Porter Co  
Capital Controls Co Inc  
Mastrri Co, The  
O'Brien & Gere Technical Services Inc  
ProMinent Fluid Controls Inc  
Smith & Loveless Inc  
Stranco Inc  
Water Equipment Tech  
Western Filter Co

**Decontamination Equipment**

ARD Environmental Inc  
Alton Geoscience



**AMERI-CAN ENGINEERING**  
219-892-5151

American Engineering  
Anguil Environmental Systems Inc  
Ben Meadows  
BioTrol Inc  
Dival Safety Equipment  
EET Inc  
Engelhard Corp  
Environmental Products & Services Inc  
Global Water  
Hazzo Services Inc  
Hazleton Environmental  
Inflatable Abatement Systems Inc  
Nuclear Associates

O'Brien & Gere Technical Services Inc  
ORSON Environmental Systems  
**ORSONS Inc**  
SEE AD ON PAGE 31  
Pentek Inc  
Spectrum Chemical & Safety Products  
Trilogy Controls Inc

**Deep Well Systems**

Atlantic Screen & Mfg Inc  
Capital Controls Co Inc  
Clean Environment Equipment  
**Diversified Well Products Inc**  
SEE AD ON PAGE 30  
EPG Companies Inc  
Hydro Group  
ORS Environmental Systems  
Trilogy Controls Inc

**Defoaming/Degreasing Equipment**

Fluidyne Corp

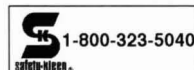

Safety-Kleen Corp

**Dehumidifiers**

Cole-Parmer Instrument Co  
G E Co  
Munters Corp - Cargocaire Div

**Deionizers**

Industrial Filter & Pump Mfg Co  
**Osmonics Inc**  
SEE AD ON PAGE 31  
Remco Engineering  
Smith & Loveless Inc  
Terra Universal  
Treatment Technologies  
United States Filter Corp  
Wheelabrator Environmental Systems Inc

**Demineralizers**

Engelhard Corp  
Hydro Group  
Industrial Filter & Pump Mfg Co  
Ionics Inc  
**Osmonics Inc**

SEE AD ON PAGE 31

Remco Engineering  
Smith & Loveless Inc  
Treatment Technologies  
United States Filter Corp  
Western Filter Co  
Wilkins-Anderson Co

**Density Instrumentation**

Automation Products Inc  
Brooklyn Thermometer Co Inc  
Cole-Parmer Instrument Co  
**Colog Inc**

SEE AD ON PAGE 32

ELE International Inc/Soiltest  
Products Div  
Nuclear Associates  
Peek Measurement Inc

**Desalination Equipment**

Aqua-Chem Inc



**Desalination Systems Inc**  
SEE AD ON PAGE 163  
Ionics Inc

**Osmonics Inc**  
SEE AD ON PAGE 31  
Remco Engineering  
Resources Conservation Co  
Smith & Loveless Inc  
United States Filter Corp  
Water Equipment Tech

**Detectors**

Assay Technology Inc  
**Auburn International Inc**  
SEE AD ON PAGE 53  
Bacharach Inc  
Bascom-Turner Instruments  
Bicon, Harshaw/Bicon Radiation  
Measurement Products  
Biosystems  
CEA Instruments  
Capital Controls Co Inc  
Control Instruments Corp  
Cosmos Gas Detection  
EPD Technology Corp  
Finnigan/Tremetrics  
Fluid Components Intl  
Grace Industries Inc  
Hazo Services Inc  
**Heath Consultants Inc**  
SEE AD ON PAGE 142

Industrial Scientific Corp  
Intek Corp/Rent-Alyzer  
International Sensor Technology  
Jerman Waterworks Supply  
LINC Quantum Analytics  
Landsauer Inc  
MSA  
McNeill International  
Metrosnics Inc  
**Miltronics Inc**  
SEE AD ON PAGE 16  
National Draeger Inc  
**Omega Engineering Inc**  
SEE AD ON PAGE 2  
Plastic Fusion Fabricators  
Ridge Tool Co  
Sensidyne Inc  
Sensor Electronics Corp  
Spectrum Chemical & Safety Products  
Tedyline Brown Engineering -  
Environmental Services  
Time Mark Corp

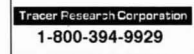

Tracer Research Corp  
Transducer Research  
Universal Enterprises Inc

**Diffusers**

Aeromix Systems Inc  
Carbtrol Corp  
EIMCO Process Equipment Co  
Engelhard Corp  
Envirex  
Ferro Corp, Specialty Ceramics Div/Filtrus Plant  
Filtrus Plant, Ferro Corp  
Hazo Services Inc  
Hazleton Environmental  
National Environmental Systems Inc  
Parkson Corp  
Plastic Fusion Fabricators  
Pollution Control Inc  
Purestream Inc  
United McGill Corp

**Digesters**

CHEMetrics Inc  
Discolp Corp  
EIMCO Process Equipment Co  
Envirex  
Inn-Nova-Tech Inc  
Marshall Industrial Technologies

Smith & Loveless Inc  
United McGill Corp  
Water Inc

**Directories**

ASTM

**Disinfection Equipment, Water**

Atlantic Ultraviolet Corp  
Capital Controls Co Inc  
High Voltage Environmental  
MIQX Corp  
**Osmonics Inc**  
SEE AD ON PAGE 31  
Ozone Research & Equipment Corp An  
Osmonics Co (OREC)  
ProMinent Fluid Controls Inc  
Smith & Loveless Inc  
Spectraserv  
United States Filter Corp  
**Wallace & Tierman Inc**  
SEE AD ON PAGE 29  
Western Filter Co  
Wheelabrator Environmental Systems Inc

**Dissolved Oxygen Detectors**

ATI Orion  
Ametek Inc  
Bailey-Fischer & Porter Co  
Ben Meadows  
CAE Instrument Rental  
CHEMetrics Inc  
CAPI Controls Co Inc  
Coastal Leasing Inc  
Cole-Parmer Instrument Co



Hach Co  
Hazo Services Inc  
**Horiba Instruments Inc**  
SEE AD ON PAGE 44

**HydroLab Corp**  
SEE AD ON PAGE 22  
Innovative Sensors Inc  
Instrumark International  
Intek Corp/Rent-Alyzer  
LINC Quantum Analytics  
**Milco Safety Rental**  
SEE AD ON PAGE 64

**Omega Engineering Inc**  
SEE AD ON PAGE 2

Orbeco Analytical Systems Inc  
Response Rentals  
SWAN/Industries Analytics  
Schneider Instrument Co  
Solomat  
Taylor Technologies  
Wilkins-Anderson Co  
YSI Inc

**Dissolved Solids Detectors**  
Ben Meadows  
Cole-Parmer Instrument Co

**Dissolved Solids Detectors**

Ben Meadows  
Cole-Parmer Instrument Co



Hach Co  
Hazo Services Inc  
Myron L Co  
Orbeco Analytical Systems Inc  
Response Rentals

**Distillation Equipment**

APV Heat Transfer/Separation Technologies

Cole-Parmer Instrument Co  
Fluid Data Inc  
Jaeger Products Inc  
Norton Chemical Process Products Corp  
**Osmonics Inc**  
SEE AD ON PAGE 31  
Petrolab Corp  
Pope Scientific  
RGF Environmental Systems Inc  
Tedder & Widhelm Consultants Inc  
Universal Process Equipment Inc  
Yara Intl Div of Calgon Carbon Corp  
Wheaton Science Products  
Wilkins-Anderson Co

**Dredges**

ARD Environmental Inc  
Ellicott Engineering Inc  
Fluidyne Corp  
H & H Pump & Dredge  
IMS Inc



**Liquid Waste Technology Inc**  
SEE AD ON PAGE 35

Quality Industries Inc  
SRS Crisafulli Inc

**Dredging Services**

ARD Environmental Inc  
**Carylon Corp**  
SEE AD ON PAGE 66  
AWD Technologies Inc  
FBA Environmental Inc  
Ferrick Construction Co Inc  
**Liquid Waste Technology Inc**  
SEE AD ON PAGE 35

O'Brien & Gere Technical Services Inc  
SRS Crisafulli Inc  
Sevenson Environmental Services Inc  
Spectraserv

**Drilling, Water**

Alliance Environmental Inc  
Atlantic Screen & Mfg Inc  
Atlantic Testing Laboratories Limited  
Braun Intertec Corp  
Disclo Corp

**Diversified Well Products Inc**  
SEE AD ON PAGE 30

EDAC Inc  
Enco EMC Fiberglass Casing & Well Screens  
Hydro Group  
L Robert Kimball & Associates  
R E Wright Associates Inc (REWI)  
Wheelabrator Environmental Systems Inc

**Drum Deheader**

Bird-X Inc  
Gurman Container & Supply Corp  
RMJ Machinery Inc  
WESCO Mfg Co  
Youngstown Barrel & Drum Co

**Drum Pumps**

Ben Meadows  
Cole-Parmer Instrument Co  
Dival Safety Equipment  
Fisher Scientific Safety Products Div  
Gurman Container & Supply Corp  
Lab Safety Supply  
Labelmaster  
Lincoln Automotive  
Measurement & Flow Control  
Netzsch Inc  
**New Pig Corp**  
SEE AD ON PAGE 138  
Nortech Corp

**Omega Engineering Inc**  
SEE AD ON PAGE 2  
Pacer Pumps  
Seriflo Ltd  
Spectrum Chemical & Safety Products  
Terra Universal  
WESCO Mfg Co  
Youngstown Barrel & Drum Co

**Drums**

AE Environmental Services Inc  
Acme Container Co



Amfue!  
Bergen Barrel & Drum  
Chem-Tainer Industries  
Dival Safety Equipment  
**Diversified Well Products Inc**  
SEE AD ON PAGE 30  
ENPAC Corp  
Environmental Products & Services Inc



Enviropack  
Fisher Scientific Safety Products Div  
Gurman Container & Supply Corp  
Hazo Services Inc  
J J Keller & Associates Inc  
Lab Safety Supply  
Labelmaster  
Maxi Container Inc  
Measurement & Flow Control  
Process Solutions  
Skolnik Industries Inc  
Ultratech International  
Youngstown Barrel & Drum Co

**Drying Equipment**

ABB Raymond  
APV Heat Transfer/Separation Technologies  
ARDE Barinco Inc  
Alar Engineering Corp



Andritz Ruthner Inc  
Baler Equipment Co  
Balston Inc  
College Research Corp (CORECO)  
Engelhard Corp  
Georgia Steel & Chemical  
Glenro Inc  
Heyl & Patterson Inc  
Kornline Sanderson  
MEC Co  
Munters Corp - Cargocaire Div  
**Niro Inc**  
SEE AD ON PAGE 51

Stokes Vacuum Inc  
Stord Inc



Swenson Process Equipment Inc  
United McGill Corp  
Universal Process Equipment Inc  
Wheelabrator Environmental Systems Inc  
Winsor & Jerauld  
Wyssmont

**Ducts/Stacks/Chimneys**

Air Plastics Inc  
 Breslove Separator Co Inc  
 Duall Div Met-Pro Corp  
 Environmental Techniques  
 Harborlite Corp  
 Micro Air, Air Cleaners by Metal-Fab Inc  
 Midwesco Filter Resources Inc  
 NAO Inc  
 Raytheon Engineers &  
 Constructor/Raytheon Enviro Svc  
 Schuller International Inc  
 Tri-Mer Corp  
 Turner EnviroLogic Inc  
 United McGill Corp  
 Wheelabrator Environmental  
 Systems Inc

**Dust Collector Accessories/Supplies**

A P Buck Inc  
 Aerology Inc  
 Agel Manufacturing Co  
 Airotech  
 Auburn International Inc  
**SEE AD ON PAGE 33**  
 B A G Corp  
 College Research Corp (CORECO)  
 Ducon Environmental Systems Inc  
 Durr Industries Inc  
 Dustvent Inc  
 Engelhard Corp  
 G E Co  
 Griffin Environmental Co Inc  
 Lamson Corp  
 MAC Environmental A Div of MAC  
 Equipment Inc  
 Meyer WM W & Sons Inc  
 Midwesco Filter Resources Inc  
 Nederman Inc  
 Nilisk of America Inc  
 Spectronics Corp  
 Tri-Mer Corp  
 United McGill Corp  
 Vacuum Engineering  
 Vector Technologies Ltd  
 W L Gore & Associates Inc  
 Wheelabrator Air Pollution Control

**Dust Collector Controls**

Airotech  
 Auburn International Inc  
**SEE AD ON PAGE 33**  
 Dwyer Instruments Inc  
 G E Co  
 Griffin Environmental Co Inc  
 JBI Spray Booth Systems  
 MAC Environmental A Div of MAC  
 Equipment Inc  
 Midwesco Filter Resources Inc  
 Minuteman Intl Inc  
 United Air Specialist  
 Wheelabrator Air Pollution Control  
 Wheelabrator Environmental  
 Systems Inc

**Dust Suppression Systems**

Advanced Air Tech Inc

 **612-933-9006**  
 ag-chem  
 Environmental Services Inc

Ag-Chem Equipment Co  
 DGE Inc  
 G E Co  
 Martin Engineering

 **1-800-648-7400**  
 Martin Marietta Magnesia Specialties Inc  
 Misonix Inc

Morian & Morlan Inc  
 Naico Chemical Co  
 Nilisk of America Inc  
 Pentek Inc  
 Spraying Systems Co  
 United McGill Corp  
 Western Filter Co

**Electrostatic Precipitator**

Aerology Inc  
 Air Plastics Inc  
 Air Quality Engineering  
 Ambient Engineering Inc  
 Babcock & Wilcox  
 Beltran Associates Inc  
 Burns & McDonnell

 **516-467-1600**

Clean Gas Systems Inc  
 Ducon Environmental Systems Inc  
 Durr Industries Inc  
 Environmental Techniques  
 G E Co  
 Micro Air, Air Cleaners by Metal-Fab Inc  
 Midwesco Filter Resources Inc  
 Raytheon Engineers &  
 Constructor/Raytheon Enviro Svc  
 Trion Inc  
 United McGill Corp  
 Wheelabrator Air Pollution Control  
 Wheelabrator Environmental  
 Systems Inc

**Electrostatic Precipitator Supplies/Accessories**

Air Quality Engineering  
 Airotech  
 Ambient Engineering Inc  
 Babcock & Wilcox  
 Clean Gas Systems Inc  
 Ducon Environmental Systems Inc  
 Durr Industries Inc  
 G E Co  
 Micro Air, Air Cleaners by Metal-Fab Inc  
 Midwesco Filter Resources Inc  
 United McGill Corp  
 Wheelabrator Air Pollution Control

**Elevators**

ABB Raymond  
 Air Technical Industries  
 Kinane Engineering

**Emergency Response Training Services**

AE Environmental Services Inc  
 AIG Consultants Inc  
 Arthur D Little Inc  
 Burns & McDonnell  
 C2T Group Ltd  
 CHEM-Tel Inc

 **310-804-0305**  
 COMCO, INC.  
 ENVIRONMENTAL & SAFETY SERVICES

COMCO Inc  
 Con-Test  
 Detail Associates Inc  
 ENSCI Environmental Inc  
 ERM Group, The  
 Eroncon Services Inc  
 Enviro-Sciences Inc  
 Environmental Products & Services Inc  
 Environmental Resource Center  
 Ergo-Medical Inc  
 FERtech Environmental Inc  
 Ferrick Construction Co Inc  
 Haz Mat Containment Corporation  
 JT Baker Chemical Inc  
 Mabbett & Associates Inc

**New Pig Corp**  
**SEE AD ON PAGE 138**

Occupational Health & Hygiene Corp of  
 America  
 R E Wright Associates Inc (REWI)  
 Sunshine Technology Corp  
 Waid & Associates

 **800-324-2744**  
 Williams Knowledge Systems Inc

**SEE AD ON PAGE 9**  
 Yellow Logistics Services Inc

**Employment Services**

AE Environmental Services Inc  
 Vamco Engineering Group

**Enclosures, Instrument/Valve**

Environmental Monitor Systems Inc  
 Inflatable Abatement Systems Inc  
 Parkline Inc  
 Plastic Fab Inc  
 Tracom Inc

**Enclosures, Structural**

Bally Engineered Structures Inc  
 EASI-SET Industries

 **207-324-4427**

EKTO Mfg Corp  
 Environmental Monitor Systems Inc  
**Fabric Building Systems Inc**  
**SEE AD ON PAGE 32**

H & H Pump & Dredge  
 Inflatable Abatement Systems Inc  
 JBI Spray Booth Systems  
 Kinane Engineering  
 LEXICON Environmental Associates Inc  
**Met-One Instruments Inc**  
**SEE AD ON PAGE 26**  
 O'Brien & Gere Technical Services Inc  
 Plastic Fab Inc  
 RMJ Machinery Inc  
 Reef Industries Inc  
 Safe Environmental Storage Corp  
 Temcor  
 Terra Universal  
 Tracom Inc  
 United McGill Corp

**Engine Test Equipment**

Ecom America Ltd  
 Monarch Instrument  
 Nova Analytical Systems Inc  
 Spectronics Corp

**Engineering Services**

AE Environmental Services Inc  
 ARD Environmental Inc  
 ASTB/Analytical Services Inc  
 AWD Technologies Inc

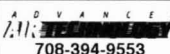
 **708-394-9553**

Advanced Air Tech Inc  
 American Standards Testing Bureau Inc  
 Angevine Acoustical Consultants Inc  
 Atlantic Testing Laboratories Limited  
 Bailey Controls Co  
 Barr Engineering Co  
 Braun Intertec Corp  
 Burns & McDonnell  
 Carbon Service & Equipment Co  
 Clean Air Engineering

Cochrane Associates Inc  
 Container Testing Laboratory Inc  
 Corporation for Environmental  
 Management  
 Dames & Moore  
 Detail Associates Inc  
 EA Engineering, Science  
 & Technology Inc  
 EMPE Inc  
 ERM Group, The  
 Eckenfelder  
 Eroncon Services Inc  
 Environex  
 Environmental Compliance Systems Corp  
 Environmental Energy Services Inc (EES)  
 Environmental Products & Services Inc  
 Environvision Group Inc, The  
 FBA Environmental Inc  
 Foster Wheeler Environmental Corp  
 Foth & Van Dyke  
 G A Huber Co  
 Galsion Corp  
 Gannett Fleming Inc  
 Geo-Technology Associates Inc  
 GeoSyntec Consultants  
 Geraghty & Miller Inc A Heidemij Co  
 Graef Anhalt Schloemer  
 Grossman, Walter B Assoc  
 Groundwater Technology Inc  
 H & H Pump & Dredge  
 H H Burkitt Project Management Inc  
 Haley & Aldrich Inc  
 Hart Crowler Inc  
 Heritage Environmental Services Inc  
 Hill International Inc  
 Hubbell, Roth & Clark Inc  
 Hunter Inc, Environmental Science  
 Huntingdon Engineering  
 & Environmental Inc  
 International Technology Corp  
 J L A Engineering Inc  
 Kennedy/Jenks Consultants  
 Kinane Engineering  
 L Robert Kimball & Associates  
 LEXICON Environmental Associates Inc  
 Lockwood Greene Engineers Inc

 **1-800-877-6050**  
 Mabbett & Associates, Inc.  
 Environmental Consulting & Engineers

Mabbett & Associates Inc  
 Marshall Industrial Technologies  
 Morrison, Knudsen Corp  
 NST Engineers

**National Technical Systems Inc**  
**SEE AD ON PAGE 17**

Normandeau Associates, RMC  
 Environmental Services Div  
 Oxford Environmental Inc  
 Parsons Engineering Science Inc  
 R E Wright Associates Inc (REWI)  
 RMT Inc  
 Radian Corp  
 Raytheon Engineers &  
 Constructor/Raytheon Enviro Svc  
 Recon Environmental  
 Rust Environmental & Infrastructure  
 Rust International Inc  
 SSM/Spotts Stevens & McCoy Inc  
 Sewall, James W Co  
 Smith & Loveliss Inc  
 Soil & Material Engineers Inc  
 Spectraserv  
 Stanley Consultants Inc  
 Stearns & Wheeler  
 Superior Environmental Corp  
 Sverdrup Environmental Inc  
 TRAK Environmental Group Inc  
 Tank Industry Consultants Inc  
 Tegger & Widheim Consultants Inc  
 Terra Bio Chem Environmental &  
 Engineering Services Inc  
 Traverse Group, The

**Unipure Environmental**  
**SEE AD ON PAGE 10**

Vamco Engineering Group  
 Waid & Associates  
 Walk, Haydel & Associates Inc  
 Wheelabrator Environmental  
 Systems Inc  
 Yellow Logistics Services Inc

**Engines**

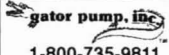
 **1-800-735-9811**

Gator Pump Inc

**Environmental Audits**

A M A R C Inc (AIHMM)  
 ABB Environmental Services Inc  
 AE Environmental Services Inc  
 ASTB/Analytical Services Inc  
 ATI  
 AWD Technologies Inc

 **518-563-5726**  
 Adirondack Environmental Associates, Inc.

Adirondack Environmental Associates Inc  
 Admiral Environmental Services Inc  
 Aerial Viewpoint  
 Alta Resource Management Services Inc  
 Alton Geoscience  
 American Scientific Instrumentation  
 American Standards Testing Bureau Inc  
 Applied Research & Development Lab  
 Applied Science & Technology Inc  
 Arthur D Little Inc  
 Atlantic Testing Laboratories Limited  
 BEM Systems Inc  
 Barr Engineering Co  
 Blasland Bouck & Lee Inc  
 Bock Environmental Service Inc  
 Brown & Root Environmental  
 Burns & McDonnell  
 C2T Group Ltd  
 Carnow, Conbar & Associates Ltd  
 Center for Hazardous Materials Research  
 ChemCycle Corp  
 Chester Environmental  
 Climatronics Corp

**Commercial Dexterity Ltd**  
**SEE AD ON PAGE 64**

Consulting Environmental Engineers Inc  
 Corbus A Div of CMS Inc  
 Corporation for Environmental  
 Management  
 Dames & Moore  
 Deeco Inc  
 Detail Associates Inc  
 Dixon Environmental Associates Inc  
 E S E Bioscience  
 EA Engineering, Science  
 & Technology Inc  
 ECOSTAT Inc  
 ELB & Associates  
 EMPE Inc  
 ENSCI Environmental Inc  
 ERM Group, The  
 ERM-South Inc  
 Eckenfelder  
 Ecotech Inc  
 Eroncon Services Inc  
 Enviro-Sciences Inc  
 Environmental Data Resources Inc  
 Environmental Fuel Systems Inc  
 Environmental Products & Services Inc  
 Environmental Resource Center  
 Environmental Standards Inc  
 Environvision Group Inc, The  
 Ergo-Medical Inc  
 FBA Environmental Inc  
 Ferrick Construction Co Inc  
 Foppe Thelen Group Inc  
 Foster Wheeler Environmental Corp

Foth & Van Dyke  
 G A Huber Co  
 Galsion Corp  
 Gannett Fleming Inc  
 General Sciences Corp  
 Geo-Technology Associates Inc  
 GeoSyntec Consultants  
 Geotrans Inc  
 Geraghty & Miller Inc A Heidemij Co  
 Global Environmental Inc  
 Graef Anhalt Schloemer  
 Groundwater Service & Supply Inc  
 Groundwater Technology Inc  
 H H Burkitt Project Management Inc  
 Haley & Aldrich Inc  
 Hart Crowser Inc  
 Haz Mat Containment Corporation  
 HazWaste Technologies Corp  
 Heritage Environmental Services Inc  
 Hill International Inc  
 Hydro Group  
 International Engineers Inc  
 International Technology Corp  
 J J Keller & Associates Inc  
 Jaca Corp  
 Kennedy/Jenks Consultants  
 L Robert Kimball & Associates  
 LEXICON Environmental Associates Inc  
 Lindmark Engineering Inc

Adirondack Environmental Associates Inc  
 Admiral Environmental Services Inc  
 Aerial Viewpoint  
 Alton Geoscience  
 American Environmental International Inc  
 American Standards Testing Bureau Inc  
 Andco Environmental Processes Inc  
 Anguil Environmental Systems Inc  
 Applied Research & Development Lab  
 Applied Science & Technology Inc  
 AquaTec Inc  
 BEM Systems Inc  
 Barr Engineering Co  
 Blasland Bouck & Lee Inc  
 Bock Environmental Service Inc  
 Braun Intertec Corp  
 Brown & Root Environmental  
 Burns & McDonnell  
 Carnow, Conibear & Associates Ltd  
 Center for Hazardous Materials Research  
 ChemCycle Corp  
 Chester Environmental  
 Cochrane Associates Inc  
 Compliance Mgmt Assoc  
 Con-Test  
 Consulting Environmental Engineers Inc  
**Convall Inc**  
**SEE AD ON PAGE 140**  
 Corporation for Environmental  
 Management  
 Dames & Moore  
 Deeco Inc  
 Detail Associates Inc  
 Dixon Environmental Associates Inc  
 Duon Environmental Systems Inc  
 EA Engineering, Science  
 & Technology Inc  
 EMPE Inc  
 ERM Group, The  
 ERM-South Inc  
 Eckenfelder  
 Ecotech Inc  
 Enercon Services Inc  
 Entropy Inc  
 Enviro-Sciences Inc  
 Envirogen Inc  
 Environmental Products & Services Inc  
 Environmental Resource Center  
 Enviroplan Inc  
 FBA Environmental Inc  
 Ferrick Construction Co Inc

Keating Environmental Management Inc  
 Kennedy/Jenks Consultants  
 Kinane Engineering  
 L Robert Kimball & Associates  
 LEXICON Environmental Associates Inc  
 Lindmark Engineering Inc  
 Lockwood Greene Engineers Inc  
 Mabbett & Associates Inc  
 Maxim Engineers Inc  
 Morrison, Knudsen Corp  
 NST Engineers  
**National Technical Systems Inc**  
**SEE AD ON PAGE 17**  
 Natisco  
 Noxso Corp  
 Ogden Environmental & Energy Services  
 Orpois Environmental Group  
 Oxford Environmental Inc  
 PDG Environmental Inc  
 Parsons Engineering Science Inc  
 Peoria Disposal Co  
 R E Wright Associates Inc (REWI)  
 Radian Corp  
 Raytheon Engineers &  
 Constructor/Raytheon Enviro Svc  
 Recon Environmental  
 Resource Consultants Inc  
 Rollins Environmental  
 Rust Environment & Infrastructure  
 Rust International Inc  
 SSM/Spotts Stevens & McCoy Inc  
 Sewall, James W Co  
 Soil & Material Engineers Inc  
 Spectraserv  
 Stanley Consultants Environmental Inc  
 Stanley Consultants Inc  
 Stearns & Wheeler  
 Superior Environmental Corp  
 Sverdrup Environmental Inc  
 TRAK Environmental Group Inc  
 Terra Bio Chem Environmental &  
 Engineering Services Inc  
 Trans-Enviro Inc  
 Traverse Group, The  
 Turner EnviroLogic Inc  
 Vamco Engineering Group  
 Vara Intl Div of Calgon Carbon Corp  
 Waid & Associates  
 Walk, Haydel & Associates Inc  
 Wonder Makers Inc

**COMCO, INC.**  
 ENVIRONMENTAL & SAFETY SERVICES  
**310-804-0305**

COMCO Inc  
 CTL Environmental Services  
 Carnow, Conibear & Associates Ltd  
 Center for Hazardous Materials Research  
 ChemCycle Corp  
 Chemical Information System  
 Chester Environmental  
 Coastwide Environmental  
 Technologies Inc  
 Commonwealth Biomonitoring  
 Con-Test  
 Consulting Environmental Engineers Inc  
 Corbus A Div of CMS Inc  
 Corporation for Environmental  
 Management  
 Dames & Moore  
 Deeco Inc  
 Dixon Environmental Associates Inc  
 E S E Bioscience  
 EA Engineering, Science  
 & Technology Inc  
 ELB & Associates  
 EMPE Inc  
 ERM Group, The  
 ERM-South Inc  
 Eckenfelder  
 Ecotech Inc  
 Enercon Services Inc  
 Enviro-Sciences Inc  
 Environmental Data Resources Inc  
 Environmental Fuel Systems Inc  
 Environmental Health & Engineering Inc  
 Environmental Products & Services Inc  
 Environmental Resource Center  
 Environmental Standards Inc  
 Envirovision Group Inc, The  
 Ergo-Medical Inc  
 FBA Environmental Inc  
 Ferrick Construction Co Inc  
 Foppe Thelen Group Inc  
 Foster Wheeler Environmental Corp  
 Foth & Van Dyke  
 G A Huber Co  
 Galsion Corp  
 Gannett Fleming Inc  
 General Sciences Corp  
 Geo-Technology Associates Inc  
 GeoSyntec Consultants  
 Geotrans Inc  
 Geraghty & Miller Inc A Heidemij Co  
 Global Environmental Inc  
 Graef Anhalt Schloemer  
 Groundwater Technology Inc  
 H H Burkitt Project Management Inc  
 Haley & Aldrich Inc  
 Hart Crowser Inc  
 Haz Mat Containment Corporation  
 HazWaste Technologies Corp  
 Heritage Environmental Services Inc  
 Hill International Inc  
 Huntingdon Engineering  
 & Environmental Inc  
 Hydro Group  
 International Engineers Inc  
 International Technology Corp  
 Jaca Corp  
 Keating Environmental Management Inc  
 Kennedy/Jenks Consultants  
 L Robert Kimball & Associates  
 LEXICON Environmental Associates Inc  
 Lindmark Engineering Inc  
 Mabbett & Associates Inc  
 Marine & Environmental Testing Inc  
 Maxim Engineers Inc  
 Morrison, Knudsen Corp  
**National Technical Systems Inc**  
**SEE AD ON PAGE 17**  
 Normandeau Associates, RMC  
 Environmental Services Div  
 Ogden Environmental & Energy Services  
 Orpois Environmental Group  
 Oxford Environmental Inc  
 Parsons Engineering Science Inc  
 R E Wright Associates Inc (REWI)  
 Radian Corp  
 Raytheon Engineers &  
 Constructor/Raytheon Enviro Svc  
 Recon Environmental  
 Rollins Environmental  
 Rust Environment & Infrastructure  
 Rust International Inc  
 SSM/Spotts Stevens & McCoy Inc  
 Sewall, James W Co  
 Soil & Material Engineers Inc  
 Stanley Consultants Environmental Inc  
 Stanley Consultants Inc  
 Stearns & Wheeler  
 Superior Environmental Corp  
 Sverdrup Environmental Inc  
 TRAK Environmental Group Inc  
 Terra Bio Chem Environmental &  
 Engineering Services Inc  
 Trans-Enviro Inc  
 Traverse Group, The  
 Trinity Consultants Inc  
 Utlicom Inc  
 Vamco Engineering Group  
 Versar Inc  
 Waid & Associates  
 Walk, Haydel & Associates Inc  
 Wellington Environmental Consulting &  
 Construction Inc  
 Wonder Makers Inc  
 Yellow Logistics Services Inc

PDG Environmental Inc  
 Parsons Engineering Science Inc  
 Professional Service Industries Inc  
 R E Wright Associates Inc (REWI)  
 Radian Corp  
 Raytheon Engineers &  
 Constructor/Raytheon Enviro Svc  
 Recon Environmental  
 Resource Consultants Inc  
 Rollins Environmental  
 Rust Environment & Infrastructure  
 Rust International Inc  
 SSM/Spotts Stevens & McCoy Inc  
 Sensidyne Inc  
 Sewall, James W Co  
 Stanley Consultants Environmental Inc  
 Stanley Consultants Inc  
 Stearns & Wheeler  
 Superior Environmental Corp  
 Sverdrup Environmental Inc  
 TRAK Environmental Group Inc  
 Terra Bio Chem Environmental &  
 Engineering Services Inc

**Tracer Research Corporation**  
**1-800-394-9929**

Tracer Research Corp  
 Trans-Enviro Inc  
 Traverse Group, The  
 Trinity Consultants Inc  
 Turner EnviroLogic Inc  
 Vamco Engineering Group  
 Versar Inc  
 W L Gore & Associates Inc  
 Walk, Haydel & Associates Inc  
 Wellington Environmental Consulting &  
 Construction Inc  
**Williams Knowledge Systems Inc**  
**SEE AD ON PAGE 9**  
 Wonder Makers Inc

**Environmental Test Chambers**

Bally Engineered Structures Inc  
 Engelhardt Corp  
 GeoSyntec Consultants  
 Inflatable Abatement Systems Inc  
 Lab-Line Instruments Inc  
 Lindberg A General Signal Co  
**National Technical Systems Inc**  
**SEE AD ON PAGE 17**  
**Omega Engineering Inc**  
**SEE AD ON PAGE 2**  
**Osmosics Inc**  
**SEE AD ON PAGE 31**  
 Ozone Research & Equipment Corp An  
 Thermoton  
 United McGill Corp  
 Yellow Logistics Services Inc

**Equipment Rental**

AE Environmental Services Inc  
 ASC Professionals  
 Air Resource Specialists Inc  
 American Scientific Instrumentation  
 Anguil Environmental Systems Inc  
 Ben Meadows  
 Brown Bear Corp  
 CAE Instrument Rental  
 Carbon Service & Equipment Co  
 Carbonair Environmental Systems  
 Clean Air Engineering  
 Clean Environment Equipment  
 Climatronics Corp  
 Coastal Leasing Inc  
**ColoJ Inc**  
**SEE AD ON PAGE 32**  
 Environmental Protection Systems  
**Environmental Restoration Systems Inc**  
**SEE AD ON PAGE 18**  
 Forrer Supply Co Inc  
 GeoPure Continental Systems & Services

**Mabbett & Associates, Inc.**  
 Environmental Remediation & Support  
**1-800-877-6050**

Mabbett & Associates Inc  
 Marine & Environmental Testing Inc  
 Morrison, Knudsen Corp  
**National Technical Systems Inc**  
**SEE AD ON PAGE 17**  
 Normandeau Associates, RMC  
 Environmental Services Div  
 Ogden Environmental & Energy Services  
 Orpois Environmental Group  
 Oxford Environmental Inc  
 Parsons Engineering Science Inc  
 R E Wright Associates Inc (REWI)  
 Radian Corp  
 Raytheon Engineers &  
 Constructor/Raytheon Enviro Svc  
 Recon Environmental  
 Rollins Environmental  
 Rust Environment & Infrastructure  
 Rust International Inc  
 SSM/Spotts Stevens & McCoy Inc  
 Sewall, James W Co  
 Soil & Material Engineers Inc  
 Stanley Consultants Environmental Inc  
 Stanley Consultants Inc  
 Stearns & Wheeler  
 Superior Environmental Corp  
 Sverdrup Environmental Inc  
 TRAK Environmental Group Inc  
 Terra Bio Chem Environmental &  
 Engineering Services Inc  
 Trans-Enviro Inc  
 Traverse Group, The  
 Trinity Consultants Inc  
 Utlicom Inc  
 Vamco Engineering Group  
 Versar Inc  
 Waid & Associates  
 Walk, Haydel & Associates Inc  
 Wellington Environmental Consulting &  
 Construction Inc  
 Wonder Makers Inc  
 Yellow Logistics Services Inc

**Environmental Engineering**

ABB Environmental Services Inc  
 AE Environmental Services Inc  
 ASTB/Analytical Services Inc  
 ATEC Associates Inc  
 ATI  
 AWD Technologies Inc  
 Accredited Laboratories Inc

**Fluor Daniel**  
**714-975-6480**

Fluor Daniel Environmental Services Inc  
 Foppe Thelen Group Inc  
 Foster Wheeler Environmental Corp  
 Foth & Van Dyke  
 G A Huber Co  
 Galsion Corp  
 Gannett Fleming Inc  
 Geo-Technology Associates Inc  
 GeoSyntec Consultants  
 Geotrans Inc  
 Geraghty & Miller Inc A Heidemij Co  
 Graef Anhalt Schloemer  
 Green Earth Technologies Corp  
 Groundwater Service & Supply Inc  
 Groundwater Technology Inc  
 H H Burkitt Project Management Inc  
 HDR Engineering Inc  
 Haley & Aldrich Inc  
 Hart Crowser Inc  
 HazWaste Technologies Corp  
 Hazen & Sawyer  
 Heritage Environmental Services Inc  
 Hill International Inc  
 Hubbell, Roth & Clark Inc  
 Huntingdon Engineering  
 & Environmental Inc  
 Hydro Group  
 International Engineers Inc  
 International Technology Corp  
 J L A Engineering Inc

**Environmental Site Assessment**

ABB Environmental Services Inc  
 ACRT Inc Environmental Specialist  
 AE Environmental Services Inc  
 ASTB/Analytical Services Inc  
 ASTM  
 ATI  
 AWD Technologies Inc  
 Adirondack Environmental Associates Inc  
 Admiral Environmental Services Inc  
 Aerial Viewpoint  
 Agency Information Consultants Inc (AIC)  
 Air Science Consultants  
 Alton Geoscience  
 American Scientific Instrumentation  
 American Standards Testing Bureau Inc  
 Angevine Acoustical Consultants Inc  
 Applied Research & Development Lab  
 Applied Science & Technology Inc  
 ARI Industries Inc  
 Arizona Instrument Corp  
 Arthur D Little Inc  
 Atlantic Testing Laboratories Limited  
 BEM Systems Inc  
 Barr Engineering Co  
 Blasland Bouck & Lee Inc  
 Bock Environmental Service Inc  
 Braun Intertec Corp  
 Brown & Root Environmental  
 Burns & McDonnell  
 C2T Group Ltd  
 CET Environmental Services Inc

Geogard Inc  
Global Water  
Godwin Pumps of America Inc  
Great Lakes Environmental Inc  
H2 Oil Recovery Equipment Inc  
Hazco Services Inc  
Intek Corp/Rent-Alyzer  
Isco Inc Environmental Div  
LINC Quantum Analytics  
Metrosonics Inc  
Nautus Inc  
ORS Environmental Systems  
Osmonics Inc

## SEE AD ON PAGE 31

Ozone Research & Equipment Corp An  
PACE Environmental Products  
Pentek Inc  
Quality Industries Inc  
R E Wright Associates Inc (REW)  
Response Rentals  
Seneca Environmental Services Inc  
Spectraser  
Universal Process Equipment Inc

## Evaporation Equipment

APV Heat Transfer/Separation  
Technologies  
Cimatronics Corp  
Ionics Inc  
Labconco Corp  
Landa Inc

## Met-One Instruments Inc

## SEE AD ON PAGE 26

## Niro Inc

## SEE AD ON PAGE 51

Novalynx Corp  
Pope Scientific  
Power Plant Services  
RGF Environmental Systems Inc  
Resources Conservation Co  
Stord Inc



**SWENSON**  
708-331-5500

Swenson Process Equipment Inc  
Technotreat Corp  
Universal Process Equipment Inc  
Wheelabrator Engineered Systems Inc -  
Memtek Products  
Wheelabrator Environmental  
Systems Inc

## Excavating Service

ATI  
Adirondack Environmental Associates Inc  
ENSCI Environmental Inc  
Environmental Products & Services Inc  
Ferric Construction Co Inc  
Lindmark Engineering Inc  
O'Brien & Gere Technical Services Inc  
R Excavating Inc "Environmental  
Contractor"  
Sevenson Environmental Services Inc

## Expansion Joints

BRD Noise & Vibration Control Inc  
EBAA Iron Sales Inc



**general  
rubber  
corporation**  
1-800-2-333-6294

General Rubber Corp/Flexible Valve Corp  
Harborlite Corp  
JM Clipper Corp  
Jerman Waterworks Supply  
Reiss Corp  
Sauereisen  
Schuller International Inc  
Wisconsin Protective Coat

## Explosion Vents

Fike Corp

## Fabric Filter

AAF International  
Airotech  
Ambient Engineering Inc  
Atlantic Screen & Mfg Inc  
Belltran Associates Inc  
Carriff Corp Inc  
Ducon Environmental Systems Inc  
Dustvent Inc  
EIMCO Process Equipment Co  
Forrer Supply Co Inc  
Griffin Environmental Co Inc  
MAC Environmental A Div of MAC  
Equipment Inc  
Midwestco Filter Resources Inc  
Plastic Fusion Fabricators  
R-P Products  
RMJ Machinery Inc  
Serifico Ltd  
TIMCO Mfg Inc  
3M

Fabricated Metal  
Products

Associated Design & Mfg  
CVM Corp  
Contech Construction Products Inc  
Convento Mfg Co Inc  
Denver Mineral Engineers Inc  
Ellicott Engineering Inc  
Griffin Environmental Co Inc  
H & H Pump & Dredge  
H2 Oil Recovery Equipment Inc  
Inn-Nova-Tech Inc  
Ionics Inc

Fabricated Metal  
Products

Associated Design & Mfg  
CVM Corp  
Contech Construction Products Inc  
Convento Mfg Co Inc  
Denver Mineral Engineers Inc  
Ellicott Engineering Inc  
Griffin Environmental Co Inc  
H & H Pump & Dredge  
H2 Oil Recovery Equipment Inc  
Inn-Nova-Tech Inc  
Ionics Inc



**JMI**  
1-800-214-1682

JWI  
Marshall Industrial Technologies  
Moran Manufacturing Inc  
Norton Chemical Process Products Corp  
Quality Industries Inc  
Royal Wire Products  
Serio-Us Lock  
Water Inc  
Zimmerman Industries Inc

## Fan Repair/Rebuilding

Abresist Corp  
G E Co  
Marshall Industrial Technologies  
Meyer WM W & Sons Inc  
New York Blower Co  
Robinson Industries Inc  
Youngstown Barrel & Drum Co  
Zurn Industries, Air Systems Div  
Fans  
Air Plastics Inc  
Anderson 2000 Inc  
Bralstord & Company  
Duall Div Met-Pro Corp



**E&G ROTRON**  
914-246-3401

E G & G Roton - Industrial Div  
G E Co  
Hartzell Fan Inc  
Kewaunee Scientific Corp  
Lindberg A General Signal Co  
Marshall Industrial Technologies  
Meyer WM W & Sons Inc  
New York Blower Co  
Robinson Industries Inc

Ziamatic Corp  
Zurn Industries, Air Systems Div

## Feeders

Acrison Inc  
Air Technical Industries  
Bailey-Fischer & Porter Co  
Bryan Steam Corp  
Capital Controls Co Inc  
Clarkson Co, The  
General Kinematics Corp  
Glen Mills Inc  
Kinane Engineering  
Masirr Co, The  
Meyer WM W & Sons Inc  
Portec Construction Equip Div  
Stoekhausen  
Vibra Screw Inc  
Wallace & Tierman Inc  
SEE AD ON PAGE 29  
Western Filter Co  
Wysmont

Feedwater Treatment  
Equipment

Bryan Steam Corp  
CHEMetrics Inc  
Capital Controls Co Inc  
Denver Mineral Engineers Inc  
Environmental Protection Systems  
High Voltage Environmental  
Hydro Group  
Luft Instruments Inc  
Osmonics Inc  
SEE AD ON PAGE 31  
Ozone Research & Equipment Corp An  
ProMetric Fluid Controls Inc  
Progressive Equipment Corp  
Remco Engineering  
Taylor Technologies  
Water Equipment Tech  
Wheelabrator Environmental  
Systems Inc

## Fiberglass Products

AFC Division of MMFG  
Air Plastics Inc  
Ameron Inc  
Aqua Tech Industries Inc  
Enco EMC Fiberglass Casing & Well  
Screens  
Fibercast Co  
Fluidyne Corp  
Harborlite Corp  
Moran Manufacturing Inc  
New York Blower Co  
Palliflex Products Co  
SEE AD ON PAGE 34  
Schuller International Inc



Smith Fiberglass Products  
Tracom Inc

Field Testing  
Instruments/Services

Alliance Environmental Inc  
American EnviroSpect Inc  
Bailey Controls Co  
Ben Meadows  
Braun Interlec Corp  
Burns & McDonnell  
CAE Express  
CAE Instrument Rental  
CHEMetrics Inc  
CTL Environmental Services  
Clean Air Engineering  
Climatronics Corp  
Colog Inc  
SEE AD ON PAGE 32

Corporation for Environmental  
Management  
Covino Environmental Consulting Inc  
Creative Errands Environmental Sample  
Transporter  
Dyna-Fid Inc  
ELE International Inc/Soiltest  
Products Div  
Entech Instruments  
Entropy Inc  
Environmental Health & Engineering Inc  
Environmental Monitor Systems Inc  
Environmental Technologies Group  
FBA Environmental Inc  
Foster Wheeler Environmental Corp  
Gascoyne Laboratories Inc  
Graef Anhalt Schloemer  
Group 206 Technologies Inc



Hach Co  
Hart Crowder Inc  
Hazco Services Inc  
Hill International Inc  
HydroLab Corp  
SEE AD ON PAGE 22  
LINC Quantum Analytics  
Maxim Engineers Inc  
Milco Safety Rental  
SEE AD ON PAGE 64  
Millipore Corp  
Monarch Instrument  
National Technical Systems Inc  
SEE AD ON PAGE 17  
Novalynx Corp  
OI Analytical  
Ogden Environmental & Energy Services  
Omega Engineering Inc  
SEE AD ON PAGE 2  
Orbeco Analytical Systems Inc  
Perstorp Analytical Inc  
R E Wright Associates Inc (REW)  
Raytheon Engineers &  
Constructor/Raytheon Enviro Svc  
Response Rentals  
SWAN/Industries Analytics  
Sensidyne Inc  
Stanley Consultants Environmental Inc  
Sverdrup Environmental Inc  
Terra Bio Chem Environmental &  
Engineering Services Inc  
Turner Designs

## Filter Accessories

Atlantic Testing Laboratories Limited  
Balston Inc  
Celite Corp  
Critical-Vac Filtration Corp (CVAC)  
Durron Co Inc, The  
Engelhard Corp  
Enviro Filtration  
Ferro Corp, Specialty Ceramics Div/Filters  
Plant  
HI-Q Environmental Products Co  
SEE AD ON PAGE 47  
Harborlite Corp  
Keystone Filter Div Met-Pro Corp  
Meflag Div Met-Pro Corp  
Midwestco Filter Resources Inc  
Osmonics Inc  
SEE AD ON PAGE 31  
Pacer Pumps Div, ASM Industries Inc  
Palliflex Products Co  
SEE AD ON PAGE 34  
Parker Hannifin Corp  
SEE AD ON PAGE 144  
Progressive Equipment Corp  
RJ Industries Inc  
Royal Wire Products  
Schuller International Inc  
Smith & Loveless Inc  
Spectrum Medical Industries  
Whalman Inc

Wheelabrator Environmental  
Systems Inc

## Filter Presses

Baler Equipment Co  
Beckart Environmental Inc  
Denver Mineral Engineers Inc  
Diagenex Inc  
Disflo Corp  
Duriron Co Inc, The  
EIMCO Process Equipment Co  
Envirex  
Industrial Filter & Pump Mfg Co

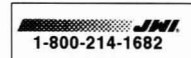

**JMI**  
1-800-214-1682

JWI  
Kornline Sanderson  
Larox Inc  
Marshall Industrial Technologies  
Netzsch Inc  
Pacer Pumps Div, ASM Industries Inc  
Parkson Corp  
Serifico Ltd  
Sevenson Environmental Services Inc  
Star Systems Filtration Division/Hilliard  
SC Inc  
Universal Process Equipment Inc  
Waste-Tech Inc  
Wheelabrator Environmental  
Systems Inc  
Zimpro Environmental Inc

## Filtration Systems

AAF International  
Activated Carbon Resources  
Aerology Inc  
Aget Manufacturing Co  
Alar Engineering Corp  
American Environmental International Inc  
Andoo Environmental Processes Inc  
Anguil Environmental Systems Inc  
Associated Design & Mfg  
Atomatic Valve Co Inc  
Baier Equipment Co  
Balston Inc  
Barnebey & Sutcliffe Corp  
Bird Machine Co Inc  
CVM Corp  
Calgon Carbon Corp  
Cameron-Yakima Inc  
Carbon Service & Equipment Co  
Carbtrol Corp  
Chemco Mfg Co Inc  
Critical-Vac Filtration Corp (CVAC)  
Denver Mineral Engineers Inc  
Disflo Corp  
Dual Safety Equipment/Diversified Well  
Products Inc  
SEE AD ON PAGE 30  
Ducon Environmental Systems Inc  
Duriron Co Inc, The  
Dustvent Inc  
EPG Companies Inc  
Engelhard Corp  
Enviro Filtration  
Fluidyne Corp  
Frontier Technology Inc  
General Carbon Corp  
Great Lakes Environmental Inc  
Hankison International  
Hazco Services Inc  
Hyde Products Inc  
Hydro Group  
Industrial Filter & Pump Mfg Co  
Ionics Inc

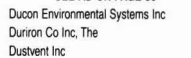

**JMI**  
1-800-214-1682

JWI  
Joseph Marketing

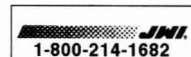

**JMI**  
1-800-214-1682



Keystone Filter Div Met-Pro Corp  
Kornline Sanderson  
Krebs Engineers  
La-Man Corp  
Larox Inc  
M-Tec Corp  
Meliag Div Met-Pro Corp  
**Met-Pro Corp Systems Div**  
SEE AD ON PAGE 43

Micro Air, Air Cleaners by Metal-Fab Inc  
Midwesco Filter Resources Inc  
Monroe Environmental Corp  
Morlan & Morlan Inc  
Netsch Inc  
Northwestern Carbon  
NovaLynx Corp  
Osmonics Inc  
SEE AD ON PAGE 31

Pacer Pumps  
Pacer Pumps Div, ASM Industries Inc  
**Parker Hannifin Corp**  
SEE AD ON PAGE 144

Parkson Corp  
Progressive Equipment Corp  
Purestream Inc  
R-P Products  
RGF Environmental Systems Inc  
RJ Industries Inc  
Remco Engineering  
Ronningen-Petter, Engineered Filter Systems  
Schreiber Corp Inc  
Serfilco Ltd

Smith & Loveless Inc  
Spectrum Medical Industries  
3M Filtration Products  
Treatment Technologies  
United States Filter Corp  
Universal Process Equipment Inc  
Water Equipment Tech  
Western Filter Co  
Whatman Inc  
Wheaton Science Products  
Wheelabrator Engineered Systems Inc -  
Mentek Products  
Wheelabrator Environmental Systems Inc  
Zmpro Environmental Inc

**Fire Safety Equipment**

AIM Safety USA Inc  
Direct Safety Co  
Dival Safety Equipment  
Fike Corp  
General Monitors  
Gurman Container & Supply Corp  
Hazco Services Inc  
Jerman Waterworks Supply  
Lab Safety Supply  
M-Tec Corp  
MSA  
National Marker Co  
**New Pig Corp**  
SEE AD ON PAGE 138

NovaLynx Corp  
Spectrum Chemical & Safety Products  
Ziamatic Corp

**Fittings**

AGA Gas Inc



Ameron  
Chemtrol Div of Nibco Inc  
Cole-Parmer Instrument Co  
Environmental Industrial Resources  
Eston Thermoplastics  
Fluoroware  
Hazco Services Inc  
Jerman Waterworks Supply  
Naylor Pipe Co  
Newage Industries



Nibco Inc  
OPW Fueling Components  
**Omega Engineering Inc**  
SEE AD ON PAGE 2

Pacer Pumps  
**Parker Hannifin Corp**  
SEE AD ON PAGE 144

Plastic Fusion Fabricators  
Plexco



Smith Fiberglass Products

**Flame Arrestors**

Dival Safety Equipment  
EPG Companies Inc  
Fisher Scientific Safety Products Div  
NAO Inc

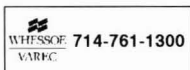

Wheosoe Varc

**Flash Point Tester**

ELE International Inc/Soiltest  
Products Div  
Fisher Scientific Safety Products Div  
Petrolab Corp  
Wilkens-Anderson Co

**Floating Baffles**

Environetics Inc  
Environmental Recovery Resources Inc  
Gundie Lining Systems Inc  
ModuTank Inc  
Plastic Fusion Fabricators  
Sunshine Technology Corp  
Watersaver Co Inc

**Floats/Pontoons**

**Diversified Well Products Inc**  
SEE AD ON PAGE 30



Gator Pump Inc  
H & H Pump & Dredge  
**Liquid Waste Technology Inc**  
SEE AD ON PAGE 35

Naylor Pipe Co  
Sunshine Technology Corp  
Watersaver Co Inc  
**Floculants**

Colloid Environmental Technologies Co  
Disctlo Corp  
**Diversified Well Products Inc**  
SEE AD ON PAGE 30

Rhone-Poulenc Inc Specialty  
Chemicals Div  
Smith & Loveless Inc  
Stockhausen

**Flotation Equipment**

AFL Industries Inc  
Cole-Parmer Instrument Co  
Aeromix Systems Inc  
Agar Corp  
Colloid Environmental Technologies Co  
EIMCO Process Equipment Co  
Enwivex  
Fluidyne Corp  
Franco Environmental Technologies

Great Lakes Environmental Inc  
Kornline Sanderson  
Or-Tec Inc  
Pollution Control Inc  
Polybac Corp  
SRS Crisafulli Inc  
Tenco Hydro Inc

**Flow Instrumentation**

A P Buck Inc  
ADS Environmental Services Inc  
Air Monitor Corp  
Alnor Instrument Co  
American Sigma Inc  
**Auburn International Inc**  
SEE AD ON PAGE 53

**Badger Meter Inc**  
SEE AD ON PAGE 4

Bailey Controls Co  
Bailey-Fischer & Porter Co  
Barnant Co  
Ben Meadows  
Brooks Instrument  
CAE Express  
Campbell Scientific Inc  
Clean Air Engineering  
Coastal Leasing Inc  
Cole-Parmer Instrument Co  
**Colog Inc**  
SEE AD ON PAGE 32

Control Electronics Inc  
Controlotron  
Dial Industrial Corp  
Dickson Co, The



**Dieterich Standard, a Dover Industries Co**  
SEE AD ON PAGE 64

Dival Safety Equipment  
**Diversified Well Products Inc**  
SEE AD ON PAGE 30

Dwyer Instruments Inc  
Dynasonics Inc  
EIT  
EPG Companies Inc  
Environmental Services & Products Inc  
Enviroplan Inc  
Fluid Components Intl  
G O Environment Inc  
Gems Sensors Div  
George Fischer Inc



Global Water  
**HI-Q Environmental Products Co**  
SEE AD ON PAGE 47

Harwil Corp  
Hazco Services Inc  
Hersey & Measurement  
ISTA Energy Systems Corp  
Instrumark International  
Instruments Direct Inc  
Invalco Inc  
Inventron Inc  
Iso Co Environmental Div  
J + W Scientific  
Lamson Corp  
MKS Instruments Inc  
Mastrm Co, The  
**Milltronics Inc**  
SEE AD ON PAGE 16

Newport Electronics Inc  
NovaLynx Corp  
**Omega Engineering Inc**  
SEE AD ON PAGE 2

**Osmonics Inc**  
SEE AD ON PAGE 31  
Pace Transducer/CJ Enterprise  
Panametrics PCI Div  
Peek Measurement Inc

Perstorp Analytical Inc  
Rochester J L Co  
SIE Div of Computalog USA  
Serfilco Ltd  
Solomat  
Soltec Corp  
Sparing Instruments Co Inc  
TSI Inc/Environmental Measurements &  
Controls Div  
Thomas Products Limited  
Turner Associates Inc  
Turner Designs



Water Specialties Corp

**Flowmeters, Mass**

ABB K-Flow Inc  
Air Monitor Corp  
**Auburn International Inc**  
SEE AD ON PAGE 53

Bailey Controls Co  
Bailey-Fischer & Porter Co  
Brooks Instrument  
Cole-Parmer Instrument Co  
Controlotron  
Dival Safety Equipment  
Fluid Components Intl  
Hazco Services Inc  
ISTA Energy Systems Corp  
Invalco Inc  
J + W Scientific  
Jerman Waterworks Supply  
MKS Instruments Inc  
Marshall Industrial Technologies  
Midwesco Filter Resources Inc  
**Omega Engineering Inc**  
SEE AD ON PAGE 2

Peek Measurement Inc  
Phenomenex  
Sensidyne Inc  
Sparing Instruments Co Inc  
United Sciences Inc

**Flowmeters, Variable Area**

Bailey Controls Co  
Bailey-Fischer & Porter Co  
Barnant Co  
Brooks Instrument  
Coastal Leasing Inc  
Cole-Parmer Instrument Co  
Dival Safety Equipment  
Dwyer Instruments Inc  
George Fischer Inc  
Hazco Services Inc  
Midwesco Filter Resources Inc  
**Omega Engineering Inc**  
SEE AD ON PAGE 2

Schutte & Koerting Division Kertema Inc  
**Wallace & Tiernan Inc**  
SEE AD ON PAGE 29

**Flue Gas Conditioning**

Anderson 2000 Inc  
Beltran Associates Inc  
College Research Corp (CORECO)  
Environmental Energy Services Inc (EES)  
Fluid Data Inc  
Johnson Matthey Env  
Misonix Inc  
NST Engineers  
PACE Environmental Products  
Sparing Systems Co



Surface Combustion Corp  
United McGill Inc

Wheelabrator Air Pollution Control  
Wheelabrator Environmental Systems Inc

**Flue Gas Desulfurization**

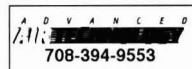

Advanced Air Tech Inc  
Advanced Industrial Technology Corp  
Anderson 2000 Inc  
**Badger Meter Inc**  
SEE AD ON PAGE 4

Beltran Associates Inc  
Burns & McDonnell  
Chemical Lime Co



Clean Gas Systems Inc  
Ducon Environmental Systems Inc  
Koch Engineering Co Inc  
Kornline Sanderson  
Morrison, Knudsen Corp  
Norton Chemical Process Products Corp  
Noxso Corp  
Radian Corp  
Raytheon Engineers &  
Constructor/Raytheon Enviro Sv  
Spraying Systems Co  
Stanley Consultants Inc  
United McGill Corp  
Universal Sensors & Devices Inc  
Wheelabrator Air Pollution Control  
Wheelabrator Environmental Systems Inc  
Zurn Industries, Air Systems Div

**Flumes/Weirs**

Abresist Corp  
Bailey-Fischer & Porter Co  
Environmental Services & Products Inc  
Free Flow Inc  
Global Water  
Instrumark International  
Plastic Fab Inc  
Thel Mar Co  
Tracom Inc

**Flushing/Cleaning Equipment**

Guzzler Mfg Inc  
Mole Master Services Corp  
RMJ Machinery Inc  
Wheelabrator Environmental Systems Inc

**Fly Ash Recovery/Treatment Systems**

ABB Raymond



Amfue!  
Automation Products Inc  
Breslove Separator Co Inc  
Guzzler Mfg Inc  
Kinane Engineering  
Packaging Research & Design  
Portec Construction Equip Div  
R E Wright Associates Inc (REW)  
Raytheon Engineers &  
Constructor/Raytheon Enviro Sv  
SRS Crisafulli Inc  
Stanley Consultants Inc  
Vac-U-Max  
Vibra Screw Inc  
Wheelabrator Air Pollution Control

## Freeze Protection

Wheelabrator Environmental Systems Inc  
Zimmerman Industries Inc

## Freeze Protection

Amtuel  
Climatronics Corp  
Engelhard Corp  
Horizontal Technologies Inc

## Fume Exhaust System

Absorbent Products  
Aerology Inc  
Air Plastics Inc  
American Environmental International Inc  
Atlas Minerals & Chemicals Inc  
CMI-Schneible Co  
CVM Corp



Clean Gas Systems Inc  
Dual Div Met-Pro Corp  
Ducon Environmental Systems Inc  
Dustvent Inc  
Kewaunee Scientific Corp  
Micro Air, Air Cleaners by Metal-Fab Inc  
Misonix Inc  
Nederman Inc  
New York Blower Co



Surface Combustion Inc  
Terra Universal  
Tri-Mer Corp  
Turner EnviroLogic Inc  
United McGill Corp

## Fume Hoods

Air Plastics Inc  
CMI-Schneible Co  
CVM Corp  
Captair Lab-X Inc  
Cole-Parmer Instrument Co  
Dual Div Met-Pro Corp  
Ducon Environmental Systems Inc  
Fisher Scientific Safety Products Div  
Kewaunee Scientific Corp  
Lab Safety Supply  
Labconco Corp  
Misonix Inc  
Nederman Inc  
Nuair Inc  
Nuclear Associates



Terra Universal  
Tri-Mer Corp  
Turner EnviroLogic Inc  
United McGill Corp  
Wilkins-Anderson Co

## Gas Chromatographs

American Scientific Instrumentation  
Antek Instruments Inc  
Celite Corp  
Cole-Parmer Instrument Co  
E S Industries  
Finnigan/Tremetrics  
Fluid Data Inc  
Foxboro Co, The  
**SEE AD ON PAGE 46**  
HNU Systems Inc  
Hazco Services Inc

## Heath Consultants Inc

**SEE AD ON PAGE 142**

Intek Corp/Rent-Alyzer  
LINC Quantum Analytics  
OI Analytical  
PACE Environmental Products  
Perkin-Elmer Corp  
**Photovac Monitoring Instruments**

**SEE AD ON PAGE 42**

R E Wright Associates Inc (REWI)  
SRI Instruments  
Sensidyne Inc  
Sentex Systems Inc  
Varian Instruments

## Gas Cooling Equipment

CAE Express  
Croll Reynolds Co Inc  
Misonix Inc  
Neslab Instruments Inc  
Spraying Systems Co

## Gas Detectors

AIM Safety USA Inc  
Anarad Inc  
Arizona Instrument Corp  
Assay Technology Inc  
Baharach Inc  
Bailey-Fischer & Porter Co  
Bascom-Turner Instruments  
Ben Meadows  
Biosystems  
Bruel & Kjaer Instruments  
CEA Instruments  
Capital Controls Co Inc  
Chem-Tex Corp  
Cole-Parmer Instrument Co  
Columbia Science Industries Co



Control Instruments Corp  
Cosmos Gas Detection  
Dasbi Environmental Corp



Detector Electronics Corp  
Dival Safety Equipment  
Dyna-Fid Inc  
EIT



ENMET Corp  
EPD Technology Corp  
EPG Companies Inc  
Environmental Monitor Systems Inc  
Environmental Technologies Group  
Fisher Scientific Safety Products Div  
Foxboro Co, The  
**SEE AD ON PAGE 46**



Gas Tech Inc  
General Analysis Corp  
General Monitors  
Grace Industries Inc  
HNU Systems Inc  
Hazco Services Inc  
**Heath Consultants Inc**  
**SEE AD ON PAGE 142**  
**Horiba Instruments Inc**  
**SEE AD ON PAGE 44**  
Industrial Scientific Corp  
Intek Corp/Rent-Alyzer  
International Sensor Technology

Jerman Waterworks Supply  
LINC Quantum Analytics  
Landaauer Inc  
MKS Instruments Inc  
MSA  
Marshall Industrial Technologies  
McNeill International  
Metrosonics Inc  
Midwestco Filter Resources Inc  
**Milco Safety Rental**

**SEE AD ON PAGE 64**

National Draeger Inc  
Neotronics  
**Omega Engineering Inc**  
**SEE AD ON PAGE 2**

**Photovac Monitoring Instruments**

**SEE AD ON PAGE 42**

Rosemount Analytical Inc  
Scott Aviation, A Figgie Intl Co  
Sensidyne Inc  
Sensor Electronics Corp  
Sentex Systems Inc  
Servomex Co Inc  
Sierra Monitor Corp  
Spectrum Chemical & Safety Products  
Teledyne Brown Engineering/Analytical Instruments  
Thermo Environmental Instruments  
Transducer Research

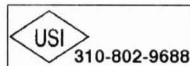

U S Industrial Products Co Inc  
Universal Enterprises Inc  
Universal Sensors & Devices Inc  
**Wallace & Tierman Inc**  
**SEE AD ON PAGE 29**

## Gas Source/Supplies

Environmental Industrial Resources  
Hazco Services Inc  
Intek Corp/Rent-Alyzer  
Liquid Carbonic

## Gas Storage Equipment

AGA Gas Inc  
Aero-Prop Utilized Fueler Inc  
Convall Inc  
**SEE AD ON PAGE 140**

Engelhard Corp

**Safety Storage Inc**

**SEE AD ON PAGE 70**

Total Containment Inc

## Gaskets/Packing/Seals

Gurman Container & Supply Corp  
Jim Clapper Corp  
John Crane Inc  
Marshall Industrial Technologies  
Midwestco Filter Resources Inc  
**Parker Hannifin Corp**  
**SEE AD ON PAGE 144**  
Presray Corp  
Reiss Corp  
W L Gore & Associates Inc  
X-Pando Products Co

## Generators

AirSep Corp  
Balston Inc  
G E Co  
Progressive Equipment Corp  
Universal Process Equipment Inc  
Westinghouse Motor Co

## Geographic Information Systems

A I W Inc  
Agency Information Consultants Inc (AIC)  
Atlantic Testing Laboratories Limited  
Burns & McDonnell

## Groundwater Testing & Monitoring Equipment

CET Environmental Services Inc  
Chester Environmental  
Corporation for Environmental Management  
EA Engineering, Science & Technology Inc  
Earth Resource Mapping  
FBA Environmental Inc  
Geotrans Inc  
Integrach Corp  
L Robert Kimball & Associates  
Morrison, Knudsen Corp  
R E Wright Associates Inc (REWI)  
Radian Corp  
Rust Environment & Infrastructure  
Rust International Inc  
Sewall, James W Co  
Stanley Consultants Inc

## Geophysical Instruments

AE Environmental Services Inc  
**Colog Inc**  
**SEE AD ON PAGE 32**  
EG & G Marine Instruments  
ELE International/IntSoltest  
Products Div  
Geophysical Survey Systems Inc



Mount Sopris Instrument Co  
**SEE AD ON PAGE 35**  
NovaLynx Corp  
Pace Transducer/CJ Enterprise  
R E Wright Associates Inc (REWI)

## Geotextiles

Amoco Fabrics & Fibers Co  
Atlantic Screen & Mfg Inc  
Claymax Corp  
Contech Construction Products Inc  
Environmental Protection Inc  
Fluid Systems  
Fonner Supply Co Inc  
Gundie Lining Systems Inc  
ModuTank Inc  
National Seal Co  
Plastic Fusion Fabricators  
R E Wright Associates Inc (REWI)  
Reel Industries Inc  
Synthetic Industries - Construction  
Products Div  
Tenax Corp  
Watersaver Co Inc

## Glassware



Eagle-Picher/Env Science & Technology  
Ferro Corp, Electronic & Specialty Glasses  
Glass Corp  
Gurman Container & Supply Corp  
Perstorp Analytical Inc  
Pope Scientific  
Spectrum Medical Industries  
Wheaton Science Products  
Wilkins-Anderson Co

## Groundwater Reclamation

AE Environmental Services Inc  
AFL Industries Inc  
AWD Technologies Inc  
Alliance Environmental Inc  
Alton Geoscience  
Artesian Environmental  
Atlantic Screen & Mfg Inc  
Atlantic Testing Laboratories Limited  
Carbon Service & Equipment Co  
Clean Environment Equipment

## Conspan Bridge Systems

**Diversified Well Products Inc**

**SEE AD ON PAGE 30**

Dual Div Met-Pro Corp  
EA Engineering, Science & Technology Inc  
Eckelder  
Ecotech Inc  
**Ejector Systems Inc**  
**SEE AD ON PAGE 52**  
Electrosynthesis Co  
Environmental Fuel Systems Inc  
Environmental Products & Services Inc  
**Environmental Restoration Systems Inc**  
**SEE AD ON PAGE 18**

Geo-Technology Associates Inc  
Geraghty & Miller Inc A Heidemij Co  
Great Lakes Environmental Inc  
Groundwater Technology Inc  
HazWaste Technologies Corp  
Hazleton Environmental  
Heritage Environmental Services Inc  
Hill International Inc  
Horizontal Technologies Inc  
Hydro-Terra Inc  
L Robert Kimball & Associates  
LEXICON Environmental Associates Inc  
Lindmark Engineering Inc  
MIOX Corp  
Martin Marietta Magnesia Specialties Inc

**Mobile Process Technology**

**SEE AD ON PAGE 48**

Morrison, Knudsen Corp

National Environmental Systems Inc

**National Technical Systems Inc**

**SEE AD ON PAGE 17**

Norit Americas Inc

O'Brien & Gere Technical Services Inc

PDG Environmental Inc

Parsons Engineering Science Inc

R E Wright Associates Inc (REWI)

RMT Inc

Raytheon Engineers & Constructors/Raytheon Enviro Svc

Remco Engineering

Rust Environment & Infrastructure

Rust International Inc

Smith & Loveless Inc

Superior Environmental Corp

Sverdrup Environmental Inc

3M Filtration Products

Traverse Group, The

Trilogy Controls Inc

**Unipure Environmental**

**SEE AD ON PAGE 10**

Wheelabrator Engineered Systems Inc -

Memtek Products

## Groundwater Testing & Monitoring Equipment

AE Environmental Services Inc

ATI

Accredited Laboratories Inc

Advanced Control Systems

Agar Corp

Alliance Environmental Inc

Alton Geoscience

American EnviroSpec Inc

Applied Science & Technology Inc



**Art's Manufacturing & Supply (AMS)**

**SEE AD ON PAGE 53**

Artesian Environmental

Atlantic Screen & Mfg Inc

Atlantic Testing Laboratories Limited

BEM Systems Inc

Bailey-Fischer & Porter Co

Ben Meadows

CHEMetrics Inc

Capital Controls Co Inc

**Colog Inc**  
**SEE AD ON PAGE 32**  
 Consulting Environmental Engineers Inc  
 Dancer Communications Inc  
 Dival Safety Equipment

**Diversified Well Products Inc**  
**SEE AD ON PAGE 30**

ELB & Associates  
 ELE International Inc/Soiltest  
 Products Div  
 Enco EMC Fiberglass Casing & Well  
 Screens  
 Environmental Fuel Systems Inc  
 Environmental Industrial Resources  
 Environmental Products & Services Inc  
 Fluoroware

**Foxboro Co, The**  
**SEE AD ON PAGE 46**

G O Environment Inc  
 General Analysis Corp  
 Geoguard Inc  
 Global Water  
 HNU Systems Inc  
 Hazco Services Inc  
 Hellma  
 Hill International Inc

**Horiba Instruments Inc**  
**SEE AD ON PAGE 44**

Hydro Group  
**Hydrolab Corp**  
**SEE AD ON PAGE 22**  
 Intek Corp/Rent-Alyzer



**In-Situ Inc.**  
 The Solutions People  
 1-800-446-7488



**Inervoc**  
 System Specifications Specialists  
 1-800-433-8487

Intervac  
 Keating Environmental Management Inc  
 Keco R & D Inc  
 L Robert Kimball & Associates  
 LINC Quantum Analytics  
 Lab Safety Supply  
 Marshalk Corp  
 Microbios Corp  
**Mico Safety Rental**  
**SEE AD ON PAGE 64**  
 Millipore Corp  
 Monarch Instrument  
 Morrison, Knudsen Corp



**MOUNT SOPRIS**  
 Instrument Company, Inc.  
 303-279-3211

**Mount Sopris Instrument Co**  
**SEE AD ON PAGE 35**

NovaLynx Corp  
 OI Analytical  
 ORS Environmental Systems  
**Omega Engineering Inc**  
**SEE AD ON PAGE 2**

Orbeco Analytical Systems Inc  
 Perkin-Elmer Corp

**Photovac Monitoring Instruments**  
**SEE AD ON PAGE 42**

Progressive Equipment Corp  
 Protec  
 QED GroundWater Specialists  
 R E Wright Associates Inc (REW)  
 Raytheon Engineers &  
 Constructor/Raytheon Enviro Svc  
 Recon Environmental  
 Response Rentals  
 SIE Div of Computational USA  
 SRI Instruments  
 Sensidyne Inc  
 Sentex Systems Inc  
 Soil & Material Engineers Inc  
 Solomat  
 Sparing Instruments Co Inc

Spectronics Corp  
 Superior Environmental Corp  
 TIMCO Mfg Inc  
 Taylor Technologies



**telog**  
 716-359-1110

Telog Instruments Inc  
 Terra Bio Chem Environmental &  
 Engineering Services Inc  
 Trans-Enviro Inc  
 Traverse Group, The  
 Turner Designs  
 W L Gore & Associates Inc  
 Whatman Inc  
 Wheaton Science Products  
 YSI Inc

**Groundwater Treatment/Services**

AE Environmental Services Inc  
 AGA Gas Inc  
 ARD Environmental Inc  
 ATEC Associates Inc  
 ATI  
 AWD Technologies Inc  
 Adronack Environmental Associates Inc  
 Aeromix Systems Inc  
 Alliance Environmental Inc  
 Alton Geoscience  
 American EnviroSpec Inc



**Ameron**  
 800-370-4FRP

Ameron  
 Andco Environmental Processes Inc  
 Atlantic Testing Laboratories Limited  
 Arterian Environmental  
 BEM Systems Inc  
 Barr Engineering Co  
 BioTrol Inc  
 Bioscience Inc  
 Blasland Bouck & Lee Inc  
 Book Environmental Service Inc  
 Braun Intertec Corp  
 Brown & Root Environmental  
 CET Environmental Services Inc  
 Calgon Carbon Corp  
 Carbon Activated  
 Carbonair Environmental Systems  
 Carbtrol Corp  
 Carnow, Conibear & Associates Ltd  
 Chester Environmental  
**Commercial Dexterity Ltd**  
**SEE AD ON PAGE 64**

Consulting Environmental Engineers Inc  
 Corporation for Environmental  
 Management

Creative Errands Environmental Sample  
 Transporter  
 Dames & Moore  
 Deeco Inc  
 Discllo Corp  
 Dual Div Met-Pro Corp  
 E S E Bioscience  
 EA Engineering, Science  
 & Technology Inc  
 ECOSTAT Inc  
 EMPE Inc  
 ENSCI Environmental Inc  
 EPG Companies Inc  
 ERM Group, The  
 Eckerleider  
 Ectotech Inc

**Ejector Systems Inc**  
**SEE AD ON PAGE 52**

Enron Services Inc  
 Envirex  
 Enviro-Sciences Inc  
 Environmental Fuel Systems Inc  
 Environmental Products & Services Inc  
 Environmental Protection Systems

**Environmental Restoration Systems Inc**

**SEE AD ON PAGE 18**

Environision Group Inc, The  
 FBA Environment Inc  
 Ferrick Construction Co Inc  
 Foppe Thelen Group Inc  
 Foster Wheeler Environmental Corp  
 General Carbon Corp  
 Genium Publishing Corp

**Geo-Con Inc**  
**SEE AD ON PAGE 54**

GeoPure Continental Systems & Services  
 GeoSyntec Consultants  
 Geotrans Inc  
 Geraghty & Miller Inc A Heidemij Co  
 Graef Anhalt Schloemer  
 Groundwater Service & Supply Inc  
 Groundwater Technician Services Inc  
 Groundwater Technology Inc  
 Hart Crowler Inc  
 Hayward Baker Environmental  
 HazWaste Technologies Corp  
 Hazleton Environmental  
 Heritage Environmental Services Inc  
 High Voltage Environmental  
 Hill International Inc  
 Horizontal Technologies Inc  
 Hydro Group  
 Hydro-Terra Inc  
 International Technology Corp  
 Keating Environmental Management Inc  
 Kennedy/Jenks Consultants  
 Koch Engineering Co Inc  
 L Robert Kimball & Associates  
 LEXICON Environmental Associates Inc  
 Lamson Corp

Lindmark Engineering Inc  
 Mabbett & Associates Inc  
 Martin Marietta Magnesia Specialties Inc  
 Medina Agriculture Products Co Inc  
**Met-Pro Corp Systems Div**  
**SEE AD ON PAGE 43**

**Mobile Process Technology**  
**SEE AD ON PAGE 48**  
 Monarch Separators Inc  
 Morrison, Knudsen Corp  
 NST Engineers  
 National Environmental Systems Inc  
**National Technical Systems Inc**  
**SEE AD ON PAGE 17**

North East Environmental Products Inc  
 Norton Chemical Process Products Corp  
 O'Brien & Gere Technical Services Inc  
 Ogden Environmental & Energy Services  
**Osmonics Inc**  
**SEE AD ON PAGE 31**

Oxford Environmental Inc  
 Parsons Engineering Science Inc  
 Peoria Disposal Co  
 Peroxidation Services Inc  
 Polybac Corp  
 Progressive Equipment Corp  
 Protec

R E Wright Associates Inc (REW)  
 RMT Inc  
 Radian Corp  
 Raytheon Engineers &  
 Constructor/Raytheon Enviro Svc  
 Recon Environmental  
 Rollins Environmental  
 Rust Environment & Infrastructure  
 Rust International Inc  
 SSM/Spotts Stevens & McCoy Inc  
 Seneca Environmental Services Inc  
 Severson Environmental Services Inc  
 Smith & Loveless Inc  
 Spectraserv  
 Stanley Consultants Inc  
 Stearns & Wheeler

Superior Environmental Corp  
 Sverdrup Environmental Inc  
 Sybron Chemicals Inc  
 Terra Bio Chem Environmental &  
 Engineering Services Inc  
 3M Filtration Products  
 Traverse Group, The

**Unipure Environmental**  
**SEE AD ON PAGE 10**

United States Filter Corp  
 Waste Stream Technology Inc  
 Western Filter Co  
 Zimpro Environmental Inc

**Hazardous Material Handling**

ABB Raymond  
 AE Environmental Services Inc  
 ARD Environmental Inc  
 Aaron Environmental Services Corp



**ALTA**  
 1-800-730-ALTA (2582)

Alta Resource Management Services Inc  
 Artesian Environmental  
 C2T Group Ltd



**COMCO, INC.**  
 ENVIRONMENTAL & SAFETY SERVICES  
 310-804-0305

COMCO Inc  
 CRX Environmental Services Inc  
 Chem-Tainer Industries  
 Chemtrol Div of Nibco Inc  
 Chlorine Specialties  
 Civacon-Dover Resources



**COMPUTER ALLII**  
 1-800-844-1400

**Computer Allii**  
**SEE AD ON PAGE 120**

**Convall Inc**  
**SEE AD ON PAGE 140**

Direct Safety Co  
 Dival Safety Equipment  
 E S E Bioscience  
 ENPAC Corp  
 ENSCI Environmental Inc  
 ERM-South Inc  
 Enercon Services Inc  
 Environmental Products & Services Inc  
 FERtech Environmental Inc  
 Foster Wheeler Environmental Corp  
 Gelok Intl Corp  
 HazWaste Technologies Corp  
 Heritage Environmental Services Inc  
 IMS Inc  
 Intec Controls Corp  
 International Technology Corp  
 Justrite Mfg Co/Div of Federal Signal Corp  
 Leapfrog Technologies  
 MSA  
 Mabbett & Associates Inc  
 National Marker Co

**New Pig Corp**  
**SEE AD ON PAGE 138**

**Niro Inc**  
**SEE AD ON PAGE 51**  
 Nuclear Associates  
 O'Brien & Gere Technical Services Inc  
 Pentek Inc  
 Peoria Disposal Co  
 Process Solutions  
 Production Systems Inc  
 RMT Inc  
 Remco Products Corp  
 Rollins Environmental  
 Rust International Inc  
 S & G Enterprises Inc  
 Safe Environmental Storage Corp

**Safety Storage Inc**  
**SEE AD ON PAGE 70**

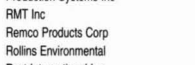

**Severson Environmental Services, Inc.**  
 716-284-0431

Severson Environmental Services Inc

Stanley-Vidmar Inc  
 Sverdrup Environmental Inc  
 TRAK Environmental Group Inc  
 Trans-Enviro Inc  
 Transport Law Research Inc  
 Traverse Group, The  
 Ultratech International  
 Vac-U-Max  
 Wellington International Consulting &  
 Construction Inc



**Williams Knowledge Systems Inc**  
**SEE AD ON PAGE 9**  
 800-324-2744

**Hazardous Material/Waste**

AE Environmental Services Inc  
 ARD Environmental Inc  
 ATI  
 AWD Technologies Inc  
 Aaron Environmental Services Corp  
 Allflex Hazardous Material Packing Inc



**ALTA**  
 1-800-730-ALTA (2582)

Alta Resource Management Services Inc  
 Alton Geoscience  
 Arterian Environmental  
 Atlantic Testing Laboratories Limited  
 Brown & Root Environmental  
 CET Environmental Services Inc



**COMCO, INC.**  
 ENVIRONMENTAL & SAFETY SERVICES  
 310-804-0305

COMCO Inc  
 Chemical Information System  
 Clean Venture/Cycle Chem



**COMPUTER ALLII**  
 1-800-844-1400

**Computer Allii**  
**SEE AD ON PAGE 120**

Discllo Corp  
 EA Engineering, Science  
 & Technology Inc  
 ENSCI Environmental Inc  
 ERM Group, The  
 ERM-South Inc  
 Enercon Services Inc  
 Environmental Products & Services Inc  
 Ferrick Construction Co Inc  
 Foster Wheeler Environmental Corp  
 GeoSyntec Consultants  
 Green Earth Technologies Corp



**HAZ-MAT CONTAINMENT CORPORATION**  
 1-800-943-6510

**Haz Mat Containment Corporation**  
**SEE AD ON PAGE 39**

Haz-Stor Co  
 HazWaste Technologies Corp  
 Heritage Environmental Services Inc  
 Hill International Inc  
 International Technology Corp  
 Jaca Corp

**Mobile Process Technology**  
**SEE AD ON PAGE 48**

National Marker Co  
 Natlisco

**New Pig Corp**  
**SEE AD ON PAGE 138**

Ogden Environmental & Energy Services  
 Parsons Engineering Science Inc  
 Peoria Disposal Co  
 R E Wright Associates Inc (REW)

RMT Inc  
Raytheon Engineers & Constructor/Raytheon Enviro Svc  
Rust International Inc  
SSI Shredding Systems Inc  
Stanley Consultants Inc  
Sverdrup Environmental Inc  
Transport Law Research Inc  
Traverse Group, The  
21 EMI/Elicam  
Wellington Environmental Consulting & Construction Inc

**Hazardous Waste Containers**

AE Environmental Services Inc  
Acme Container Co  
Allflex Hazardous Material Packing Inc  
Alta Resource Management Services Inc  
American Rolloff  
Assman Corp of America  
B A G Corp  
Baker Tanks  
Bergen Barrel & Drum  
Bes-Pac Inc

**CHEM-TAINER INDUSTRIES, INC.**  
1-800-275-2436

Chem-Tainer Industries  
Containment Corp  
Convall Inc  
SEE AD ON PAGE 140  
Convento Mfg Co Inc  
Direct Safety Co  
Dival Safety Equipment  
ENPAC Corp  
Environmental Products & Services Inc

**Enviropack**  
800-423-8188

Enviropack  
Fisher Scientific Safety Products Div  
Gurman Container & Supply Corp

**HAZ-MAT CONTAINMENT CORPORATION**  
1-800-943-6510

Haz Mat Containment Corporation  
Highland Tank  
Intl Hazmat Storage Div of Intl Cold Storage Co Inc  
JBI Spray Booth Systems  
Justriple Mfg Co/Div of Federal Signal Corp  
Lab Safety Supply  
Labelmaster  
Maxi Container Inc  
Minuleman Intl Inc  
Nalge Co  
New Pig Corp  
SEE AD ON PAGE 138  
Packaging Research & Design  
Peoria Disposal Co  
Process Solutions  
Safe Environmental Storage Corp  
Safety Storage Inc  
SEE AD ON PAGE 70  
Skolnik Industries Inc  
Spectrum Chemical & Safety Products  
21 EMI/Elicam  
Ultratech International

**Hazardous Waste Equipment**

ABB Raymond  
AE Environmental Services Inc  
ARDE Barinco Inc  
Alta Resource Management Services Inc  
Alton Geoscience  
American Gas Products Inc  
American Rolloff

Anderson 2000 Inc  
Baler Equipment Co  
Chem-Tainer Industries

**CLEMENT**  
318-377-2776

Clement Industries Inc  
Compacting Technologies  
Convento Mfg Co Inc  
Dival Safety Equipment  
EASI-SET Industries  
Ejector Systems Inc  
SEE AD ON PAGE 52  
Environmental Container Corp  
Finch Manufacturing Co Inc  
Goodway Technologies Corp  
Haz-Stor Co  
Hazo Services Inc  
Invention Inc

**JMI**  
1-800-214-1682

JMI  
LaBounty Manufacturing Div of Stanley Hydraulic Tools  
Lab Safety Supply  
MSA  
Magid Glove & Safety Mfg Co  
ModuTank Inc  
New Pig Corp  
SEE AD ON PAGE 138  
Nirol Inc  
SEE AD ON PAGE 51

Pentek Inc  
Peoria Disposal Co  
Production Systems Inc  
Quality Industries Inc  
RMJ Machinery Inc  
Remco Products Corp  
S & G Enterprises Inc  
Safe Environmental Storage Corp  
Safety Storage Inc  
SEE AD ON PAGE 70  
Spectrum Chemical & Safety Products

**SWENSON**  
708-331-5500

Swenson Process Equipment Inc  
Ultratech International  
United States Filler Corp  
Universal Process Equipment Inc  
Vac-U-Max  
Vacuum Engineering  
Vector Technologies Ltd

**Hazardous Waste Handing**

AE Environmental Services Inc  
ARD Environmental Inc  
Aaron Environmental Services Corp

**ALTA**  
1-800-730-ALTA (2582)

Alta Resource Management Services Inc  
C2T Group Ltd

**COMCO, INC.**  
ENVIRONMENTAL & SAFETY SERVICES  
310-804-0305

COMCO Inc  
Chem-Tainer Industries  
Clean Venture/Cycle Chem  
DeMarco MAX VAC Corp  
E S E Bioscience  
ENSCI Environmental Inc  
Environmental Products & Services Inc  
Gelok Intl Corp

HazWaste Technologies Corp  
International Technology Corp  
Justriple Mfg Co/Div of Federal Signal Corp  
Morrison, Knudsen Corp  
National Marker Co  
New Pig Corp

SEE AD ON PAGE 138  
O'Brien & Gere Technical Services Inc  
Peoria Disposal Co  
Raytheon Engineers & Constructor/Raytheon Enviro Svc  
Safe Environmental Storage Corp  
Safety Storage Inc  
SEE AD ON PAGE 70  
Sevenson Environmental Services Inc  
Stanley-Vidmar Inc  
Sverdrup Environmental Inc  
TRAK Environmental Group Inc  
Vacuum Engineering  
Vector Technologies Ltd

**Hazardous Waste/Material Treatment, Storage, Disposal**

AE Environmental Services Inc  
AWD Technologies Inc  
Aaron Environmental Services Corp  
Adirondack Environmental Associates Inc  
Alta Resource Management Services Inc  
Benko Products Inc  
BioTrol Inc  
Bioscience Inc  
Blasland Bouck & Lee Inc  
Braun Interlec Corp  
Brown & Root Environmental  
CET Environmental Services Inc  
Calgon Carbon Corp  
Cameron-Yakima Inc/Carylon Corp  
SEE AD ON PAGE 66

**CHEM-TAINER INDUSTRIES, INC.**  
1-800-275-2436

Chem-Tainer Industries  
Clean Venture/Cycle Chem

**COMPUTER ALLI**  
1-800-844-1400

Computer All  
SEE AD ON PAGE 120  
Convall Inc  
SEE AD ON PAGE 140  
Direct Safety Co

**DYNECOL**  
313-571-7141

Dynecol Inc  
SEE AD ON PAGE 30  
E S E Bioscience  
ENSCI Environmental Inc  
Enercon Services Inc  
Envrite Corp  
Envirogen Inc  
Environmental Products & Services Inc  
Envirosion Group Inc, The  
Fabric Building Systems Inc  
SEE AD ON PAGE 32  
Foster Wheeler Environmental Corp  
Frontier Technology Inc  
Geo-Con Inc  
SEE AD ON PAGE 54  
GeoSyntec Consultants  
Great Lakes Environmental Inc  
Green Earth Technologies Corp

**HAZ-MAT CONTAINMENT CORPORATION**  
1-800-943-6510

Haz Mat Containment Corporation  
SEE AD ON PAGE 39

Haz-Stor Co  
HazWaste Technologies Corp  
Heritage Environmental Services Inc  
High Voltage Environmental  
Highland Tank  
International Technology Corp  
Intl Hazmat Storage Div of Intl Cold Storage Co Inc  
Justriple Mfg Co/Div of Federal Signal Corp  
LEXICON Environmental Associates Inc  
Lab Safety Supply  
Labelmaster  
Lincoln Automotive

**MORRISON KNUDSEN CORPORATION**  
208-386-5502

Morrison, Knudsen Corp  
New Pig Corp  
SEE AD ON PAGE 138

Northeast Environmental Services  
O'Brien & Gere Technical Services Inc  
Parsons Engineering Science Inc  
Penberthy Electromelt  
Peoria Disposal Co  
R E Wright Associates Inc (REW)  
RMT Inc  
Raytheon Engineers & Constructor/Raytheon Enviro Svc  
Rollins Environmental  
Ross Incineration Services Inc  
Rust Environment & Infrastructure  
Rust International Inc  
S & G Enterprises Inc  
SSI Shredding Systems Inc  
SSM/Spotts Stevens & McCoy Inc

**S** 1-800-323-5040  
safety-ntec

Safety Kleen Corp  
Safety Storage Inc  
SEE AD ON PAGE 70  
Sewall, James W Co

**SC Surface Combustion**  
1-800-537-8980

Surface Combustion Inc  
Systech Environmental Corp  
TRAK Environmental Group Inc  
21 EMI/Elicam  
USPCI

**Hazardous Waste Recycling**

ABB Air Preheater Inc  
SEE AD ON PAGE 141  
AE Environmental Services Inc  
Aaron Environmental Services Corp

**ALTA**  
1-800-730-ALTA (2582)

Alta Resource Management Services Inc  
American Gas Products Inc  
American Pulverizer Co  
Atlantic Testing Laboratories Limited  
Cameron-Yakima Inc  
Carbon Service & Equipment Co  
Chem-Tainer Industries  
Chentralf Environmental Inc  
ENPAC Corp  
ENSCI Environmental Inc  
Environmental Basics Co  
Environmental Products & Services Inc

**FLUOR DANIEL**  
714-975-6480

Fluor Daniel Environmental Services Inc

Green Earth Technologies Corp  
Heritage Environmental Services Inc  
Mobile Process Technology  
SEE AD ON PAGE 48  
Peoria Disposal Co  
SSM/Spotts Stevens & McCoy Inc

**S** 1-800-323-5040  
safety-ntec

Safety Kleen Corp  
Sharples, Business Unit of Alfa Laval Separation  
Soil & Material Engineers Inc  
Stearns & Wheeler  
TRAK Environmental Group Inc  
Tedder & Widhelm Consultants Inc  
Trans-Enviro Inc  
21 EMI/Elicam  
Zimmerman Industries Inc

**Hazardous Waste Services**

AE Environmental Services Inc  
ARD Environmental Inc  
Aaron Environmental Services Corp  
Accredited Laboratories Inc  
Adirondack Environmental Associates Inc

**ALTA**  
1-800-730-ALTA (2582)

Alta Resource Management Services Inc  
Alton Geoscience  
American Gas Products Inc  
BEM Systems Inc  
Blasland Bouck & Lee Inc  
Brown & Root Environmental  
Burns & McDonnell  
Center for Hazardous Materials Research  
Cycle Corp  
Chester Environmental  
Clean Venture/Cycle Chem  
Consulting Environmental Engineers Inc  
Corporation for Environmental Management  
Dames & Moore  
E S E Bioscience  
EA Engineering, Science & Technology Inc  
EMPE Inc  
ENSCI Environmental Inc  
ERM Group, The  
Eckenfelder  
Ecotech Inc  
Enviro-Sciences Inc  
Environmental Products & Services Inc  
FBA Environmental Inc  
Ferrick Construction Co Inc

**FLUOR DANIEL**  
714-975-6480

Fluor Daniel Environmental Services Inc  
Foster Wheeler Environmental Corp  
Gannett Fleming Inc  
GeoSyntec Consultants  
Geraghty & Miller Inc A Heidmij Co  
Graef Anhalt Schloemer  
Green Earth Technologies Corp  
Haley & Aldrich Inc  
Hart Crowser Inc  
HazWaste Technologies Corp  
Heritage Environmental Services Inc  
Hill International Inc  
International Technology Corp  
Kennedy/Jenks Consultants  
L Robert Kimball & Associates  
LEXICON Environmental Associates Inc  
Mobile Process Technology  
SEE AD ON PAGE 48



Morrison, Knudsen Corp  
**National Technical Systems Inc**  
 SEE AD ON PAGE 17  
**New Pig Corp**  
 SEE AD ON PAGE 138

Normandeau Associates, RMC  
 Environmental Services Div  
 Northeast Environmental Services  
 O'Brien & Gere Technical Services Inc  
 Ogen Environmental & Energy Services  
 Oxford Environmental Inc  
 Parsons Engineering Science Inc  
 Peoria Disposal Co  
 R E Wright Associates Inc (REWI)  
 RMT Inc  
 Radian Corp  
 Rollins Environmental  
 Rust Environment & Infrastructure  
 Rust International Inc  
 SSM/Spotts Stevens & McCoy Inc

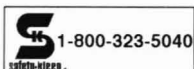

**Safety Kleen Corp**  
 Severson Environmental Services Inc  
 Soil & Material Engineers Inc  
 Stanley Consultants Environmental Inc  
 Systech Environmental Corp  
 TRAK Environmental Group Inc



Tenerx Corp  
 Trans-Enviro Inc  
 Traverse Group, The  
 21 EMI/Eticam  
 Waid & Associates

**Hazardous Waste Transportation**

AE Environmental Services Inc  
 Aaron Environmental Services Corp  
 Alta Resource Management Services Inc  
 Clean Venture/Cycle Chem



**Computer Allii**  
 1-800-844-1400  
**Computer Allii**  
 SEE AD ON PAGE 120  
 Creative Errands Environmental Sample  
 Transporter



**Dynecol Inc**  
 SEE AD ON PAGE 30  
 ENSCI Environmental Inc  
 Enwrite Corp  
 Environmental Products & Services Inc  
 Ferrick Construction Co Inc  
 Green Earth Technologies Corp  
 Heritage Environmental Services Inc  
 Morrison, Knudsen Corp  
 National Marker Co  
 Northeast Environmental Services  
 Peoria Disposal Co  
 Rollins Environmental  
**Safety Storage Inc**  
 SEE AD ON PAGE 70  
 Severson Environmental Services Inc  
 Trans-Enviro Inc  
 Transport Law Research Inc

**Hazmat Waste, Dump & Rolloff Trailer**



Clement Industries Inc

**Heat Exchangers**

**ABB Air Preheater Inc**  
 SEE AD ON PAGE 141  
 AE Environmental Services Inc  
 APV Heat Transfer/Separation Technologies  
**Adwest Technologies Inc**  
 SEE AD ON PAGE 36  
 Airex Div Adwest Technologies  
 Anderson 2000 Inc  
 Anguil Environmental Systems Inc  
 Bryan Steam Corp  
 CSM Environmental Systems Inc  
 CVM Corp  
 Cheminer Inc  
 EPG Companies Inc  
 Edwards Engineering  
 Envirex  
 Environmental Protection Systems  
 Exothermics-Eclipse Inc  
 George Fischer Inc  
 Graham Mfg Co Inc  
 H2 Oil Recovery Equipment Inc  
 Ionics Inc  
 John Crane Inc  
 Koch Engineering Co Inc  
 Neslab Instruments Inc  
 New York Blower Co  
 Nirol Inc  
 SEE AD ON PAGE 51  
 Norton Chemical Process Products Corp  
 Ross Air Systems

Swenson Process Equipment Inc  
 Trans-Enviro Inc  
 United Air Specialist  
 Universal Process Equipment Inc  
 Xchanger Inc  
 Zimpro Environmental Inc



Swenson Process Equipment Inc  
 Trans-Enviro Inc  
 United Air Specialist  
 Universal Process Equipment Inc  
 Xchanger Inc  
 Zimpro Environmental Inc

**Heat Recovery Systems**

APV Heat Transfer/Separation Technologies  
**Adwest Technologies Inc**  
 SEE AD ON PAGE 36  
 Airex Div Adwest Technologies  
 American Environmental International Inc  
 Anguil Environmental Systems Inc  
 Aqua-Chem Inc  
 Babcock & Wilcox  
 Bryan Steam Corp  
 CSM Environmental Systems Inc  
 CVM Corp  
 College Research Corp (CORECO)  
 Durr Industries Inc  
 ERS Services  
 Exothermics-Eclipse Inc  
 Glenro Inc  
 Koch Engineering Co Inc  
 Ross Air Systems  
**Salem Engelder**  
 SEE AD ON PAGE 119  
 Turner EnviroLogic Inc  
 Northeast Environmental Services  
 Zink, John Co Div of Koch  
 Engineering Co Inc

**Heating Cable/Tape**

**Omega Engineering Inc**  
 SEE AD ON PAGE 2

**Heavy Metal Detectors**

Bacharach Inc  
 Group 206 Technologies Inc  
 Hazco Services Inc  
 Orbeco Analytical Systems Inc

**Hose/Tubing**

Atlantic Screen & Mfg Inc  
 Barnant Co  
 Cole-Parmer Instrument Co  
**Diversified Well Products Inc**  
 SEE AD ON PAGE 30  
 Flexaust Co  
 Fluoroware  
 Forrer Supply Co Inc



Gator Pump Inc  
 Godwin Pumps of America Inc  
 Hazco Services Inc  
 Newage Industries  
**Parker Hannifin Corp**  
 SEE AD ON PAGE 144  
 Spectrum Medical Industries  
 Swagelok Companies, The  
 TIMCO Mfg Inc  
 Vacuum Engineering  
 Vector Technologies Ltd

**Humidity Instrumentation**

Bacharach Inc  
 Barnant Co  
 Ben Meadows  
 Brooklyn Thermometer Co Inc  
 Campbell Scientific Inc  
 Climatronics Corp  
 Cole-Parmer Instrument Co  
 Extech Instruments  
 Hazco Services Inc  
 Metrosonics Inc  
 Munters Corp - Cargocaire Div  
 Newport Electronics Inc  
 Pace Transducer/CJ Enterprise  
 Panametrics PCI Div  
 Response Rentals  
 Solomat  
 TSI Inc/Environmental Measurements & Controls Div  
 Vaisala Inc

**Hydrocarbon Detectors**

AIM Safety USA Inc  
 American Environmental International Inc  
 Anarad Inc



**Art's Manufacturing & Supply (AMS)**  
 SEE AD ON PAGE 53

Bacharach Inc  
 Ben Meadows  
 Biosystems  
 California Analytical Instruments Inc  
 Clean Air Engineering  
 Columbia Scientific  
 Control Instruments Corp  
 Dasibi Environmental Corp  
 Dyna-Fid Inc  
 ENMET Corp  
 EPG Companies Inc  
 Environmental Fuel Systems Inc  
 Environmental Technologies Group  
 Finigan/Tremetrics  
**Foxboro Co, The**  
 SEE AD ON PAGE 46



Gas Tech Inc  
 Gems Sensors Div  
 General Analysis Corp  
 Grace Industries Inc  
 Hazco Services Inc  
**Heath Consultants Inc**  
 SEE AD ON PAGE 142  
**Horiba Instruments Inc**  
 SEE AD ON PAGE 44  
 Industrial Scientific Corp  
 Intek Corp/Rent-Alyzer  
 International Sensor Technology  
 Keoc R & D Inc  
 LINC Quantum Analytics



**MMC Intl Corp**  
 SEE AD ON PAGE 23  
**Milco Safety Rental**  
 SEE AD ON PAGE 64  
 National Draeger Inc  
 Nova Analytical Systems Inc  
 ORS Environmental Systems  
**Photovac Monitoring Instruments**  
 SEE AD ON PAGE 42  
 R E Wright Associates Inc (REWI)  
 Response Rentals  
 Sensidyne Inc  
 Sensor Electronics Corp  
 Sormex Co Inc  
 Siemens Industrial Automation Inc  
 Sierra Monitor Corp  
 Spectronics Corp  
 Thermo Environmental Instruments  
 Transducer Research  
 Turner Designs

**Hydrogen Sulfide Control**

Activated Carbon Resources  
 Air Plastics Inc  
 Croll Reynolds Co Inc  
 Electrolysis Co  
 General Carbon Corp  
 Hazco Services Inc  
 LINC Quantum Analytics  
 Monroe Environmental Corp



NuTech Environmental Corp  
 Peroxidation Services Inc  
 Response Rentals



Unisorb Corp  
 Water Equipment Tech

**Hydrogen Sulfide Detectors**

AIM Safety USA Inc  
 Ametek P & AI Div  
 Anarad Inc



**Applied Automation/Hartman & Braun**  
 SEE AD ON PAGE 164

Ariel Industries Inc  
 Arizona Instrument Corp  
 Bacharach Inc  
 Bascom-Turner Instruments

Biosystems  
 CEA Instruments  
 CHEMetrics Inc  
 Clean Air Engineering  
 Climatronics Corp  
 Columbia Science Industries Co  
 Columbia Scientific



Control Instruments Corp  
 Cosmos Gas Detection  
 Dasibi Environmental Corp



Detector Electronics Corp  
 Dival Safety Equipment  
 EIT  
 ENMET Corp  
**Energy Efficiency Systems Inc**  
 SEE AD ON PAGE 11  
 Fisher Scientific Safety Products Div



Gas Tech Inc  
 General Monitors  
 Hazco Services Inc  
 Industrial Scientific Corp  
 Intek Corp/Rent-Alyzer  
 International Sensor Technology  
 Keoc R & D Inc  
 McNeill International  
 Metrosonics Inc  
 National Draeger Inc  
 Neotronics  
 Response Rentals  
 Scott Aviation, A Figgie Intl Co  
 Sensidyne Inc  
 Sensor Electronics Corp  
 Sierra Monitor Corp  
 Spectrum Chemical & Safety Products  
 Transducer Research

**Hydrological Equipment**

Campbell Scientific Inc  
 Climatronics Corp  
 Epic Inc



In-Situ Inc  
 Handar  
 Hazco Services Inc  
 Novalynx Corp  
 Vitel Inc

**Identification Systems**

Diagraph Corp  
 Integrated Software Design Inc  
 Legible Sign Inc  
 Liebert Corp  
 National Marker Co  
 Signmark Div/Brady USA Inc  
 Spectrum Chemical & Safety Products  
 Temtec Inc/TEMPbadge

**Incineration Systems**

**ABB Air Preheater Inc**  
 SEE AD ON PAGE 141  
**Adwest Technologies Inc**  
 SEE AD ON PAGE 36  
 Airex Div Adwest Technologies



Allied-Signal Inc Environmental Catalysts  
American Environmental International Inc  
Anderson 2000 Inc  
Anquil Environmental Systems Inc  
CSM Environmental Systems Inc  
CVM Corp  
Cleaver-Brooks  
College Research Corp (CORECO)  
Ducon Environmental Systems Inc



313-459-6800

Durr Industries Inc  
EPG Companies Inc  
ERS Services  
Eco Waste Solutions

SEE AD ON PAGE 55

EnerWaste Intl Corp  
Engelhard Corp  
Feco Engineered Systems Inc  
Finch Manufacturing Co Inc  
Grace TEC Systems  
Hankin Environmental Systems Inc  
International Recycling Limited  
International Technology Corp



Johnson Matthey  
610-971-3100

Johnson Matthey Env  
Kornline Sanderson  
MMT Environmental Services Inc  
Met-Pro Corp Systems Div

SEE AD ON PAGE 43



314-275-5700

Monsanto Enviro-Chem  
Morlan & Morlan Inc  
Morrison, Knudsen Corp  
NAO Inc  
Niro Inc

SEE AD ON PAGE 51

O'Brien & Gere Technical Services Inc  
Penberthy Electromelt  
Power Plant Services



412-655-0955

Process Combustion Corp  
Raytheon Engineers &  
Constructor/Raytheon Enviro Svc  
Ross Air Systems  
Salem Engelhard

SEE AD ON PAGE 119

Stanley Consultants Inc



Surface  
Combustion  
1-800-537-8980

Surface Combustion Inc  
Telkamp Systems Inc  
Universal Process Equipment Inc  
Wheelabrator Environmental  
Systems Inc  
Winsor & Jerould  
Zimpro Environmental Inc

## Indoor Air Quality

A P Buck Inc  
ATEC Associates Inc  
Air Metrics  
Air Monitor Corp

American Standards Testing Bureau Inc  
Ariel Industries Inc  
Arizona Instrument Corp  
Arthur D Little Inc  
Bacharach Inc  
Braun Intertec Corp  
Bruel & Kjaer Instruments  
CEA Instruments  
CTL Environmental Services  
Center for Hazardous Materials Research  
Con-Test  
Consulting Environmental  
Engineering Inc  
Corporation for Environmental  
Management  
Covino Environmental Consulting Inc  
Dames & Moore  
Dasibi Environmental Corp  
Detail Associates Inc  
Dickson Co, The  
Dival Safety Equipment



800-334-5478

ELB & Associates  
EMPE Inc  
ENMET Corp  
ERM Group, The  
ERM-South Inc  
Eckenfelder  
Electrosynthesis Co  
Enercon Services Inc  
Entech Instruments Inc  
Enviro-Sciences Inc  
Environmental Health & Engineering Inc  
Environmental Monitor Systems Inc  
Environmental Products & Services Inc  
Envirovision Group Inc, The  
Foxboro Co, The

SEE AD ON PAGE 46

Gascayne Laboratories Inc  
General Carbon Corp  
HNU Systems Inc  
Hart Crowler Inc  
HazWaste Technologies Corp  
Hazzo Services Inc  
Hill International Inc  
Hunter Inc, Environmental Science  
Intek Corp/Rent-Alyzer  
International Engineers Inc  
International Sensor Technology  
International Technology Corp  
Jaca Corp  
Lab Safety Supply  
Lancaster Laboratories Inc

SEE AD ON PAGE 7

Mabbett & Associates Inc  
Marine & Environmental Testing Inc  
Marshall Industrial Technologies  
Maxim Engineers Inc  
Metrosonics Inc  
Micro Air, Air Cleaners by Metal-Fab Inc  
National Draeger Inc  
Nederman Inc  
Neotronics  
Nuclear Associates  
OI Analytical  
Occupational Health & Hygiene  
Corp of America  
Ogden Environmental & Energy Services  
Orpox Environmental Group  
Oxford Environmental Inc  
Professional Service Industries Inc  
R E Wright Associates Inc (REWI)  
RMT Inc  
Radian Corp  
Raytheon Engineers &  
Constructor/Raytheon Enviro Svc  
Recon Environmental  
Rust Environment & Infrastructure  
Rust International Inc  
SSM/Spotts Stevens & McCoy Inc  
Sensidyne Inc  
Servomex Co Inc  
Sierra Monitor Corp

Soil & Material Engineers Inc  
Solomat  
Sonoma Technology Inc  
Stanley Consultants Environmental Inc  
Stanley Consultants Inc  
Stearns & Wheeler  
TSI Inc/Environmental Measurements &  
Controls Div  
Terra Bio Chem Environmental &  
Engineering Services Inc  
Traverse Group, The  
Trion Inc  
Versar Inc  
Wellington Environmental Consulting &  
Construction Inc  
Wonder Makers Inc

## Industrial Hygiene

A P Buck Inc  
ABB Environmental Services Inc  
AE Environmental Services Inc  
ATEC Associates Inc  
AWD Technologies Inc  
American Standards Testing Bureau Inc

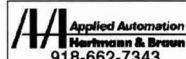

Applied Automation/Hartman & Braun  
SEE AD ON PAGE 164

Ariel Industries Inc  
Arizona Instrument Corp  
Arthur D Little Inc  
Atlantic Testing Laboratories Limited  
BEM Systems Inc  
Bacharach Inc  
Bios Intl  
Braun Intertec Corp  
Bruel & Kjaer Instruments  
C2T Group Ltd  
CTL Environmental Services  
Center for Hazardous Materials Research  
Con-Test  
Corporation for Environmental  
Management  
Covino Environmental Consulting Inc  
Dames & Moore  
Detail Associates Inc  
Dival Safety Equipment  
ELB & Associates  
EMPE Inc  
ERM Group, The  
ERM-South Inc  
Enercon Services Inc  
Enviro-Sciences Inc  
Environmental Health & Engineering Inc  
Environmental Monitor Systems Inc  
Environmental Products & Services Inc  
Ergo-Medical Inc  
Foster Wheeler Environmental Corp  
Foxboro Co, The

SEE AD ON PAGE 46

Gascayne Laboratories Inc  
General Analysis Corp  
Hart Crowler Inc  
Hazzo Services Inc  
Heritage Environmental Services Inc  
Hill International Inc  
Hill Manufacturing Co Inc  
Hunter Inc, Environmental Science  
Industrial Scientific Corp  
Intek Corp/Rent-Alyzer  
International Technology Corp  
Jaca Corp  
Kennedy/Jenks Consultants  
Lab Safety Supply  
Lancaster Laboratories Inc

SEE AD ON PAGE 7

Mabbett & Associates Inc  
Marine & Environmental Testing Inc  
Metrosonics Inc  
National Draeger Inc  
O'Brien & Gere Technical Services Inc  
Occupational Health & Hygiene Corp of  
America

Oxford Environmental Inc  
Parsons Engineering Service Inc  
Professional Service Industries Inc  
R E Wright Associates Inc (REWI)  
RMT Inc  
Radian Corp  
Raytheon Engineers &  
Constructor/Raytheon Enviro Svc  
Recon Environmental  
Research Products/Blankenship  
Rust Environment & Infrastructure  
Rust International Inc  
SSM/Spotts Stevens & McCoy Inc  
Sensidyne Inc  
Sierra Monitor Corp  
Soil & Material Engineers Inc  
Solomat  
Spectrum Chemical & Safety Products  
Stanley Consultants Environmental Inc  
Stearns & Wheeler  
Sverdrup Environmental Inc  
TSI Inc/Environmental Measurements &  
Controls Div  
Terra Bio Chem Environmental &  
Engineering Services Inc  
United Sciences Inc  
Versar Inc  
Williams Knowledge Systems Inc

SEE AD ON PAGE 9

Wunder Makers Inc  
Inline Mixers

Atlantic Screen & Mfg Inc  
Cheminer Inc  
Glen Mills Inc  
Koch Engineering Co Inc  
Mastrro Co, The  
Morehouse-Cowles Inc  
National Bulk Equipment Inc

## Instrument Rental

ASC Professionals  
Air Metrics  
Air Resource Specialists Inc  
American Scientific Instrumentation  
CAE Instrument Rental  
Clean Air Engineering  
Coastal Leasing Inc  
Colog Inc

SEE AD ON PAGE 32

Diversified Well Products Inc  
SEE AD ON PAGE 30

Dyna-Fid Inc  
Environmental Monitor Systems Inc  
Hazzo Services Inc  
Industrial Scientific Corp  
Intek Corp/Rent-Alyzer  
Iso Inc Environmental Div  
LINC Quantum Analytics  
Metrosonics Inc



800-775-1738

Milco Safety Rental

SEE AD ON PAGE 64



Mount Sopris Instrument Co  
SEE AD ON PAGE 35  
Pace Transducer/CJ Enterprise  
R E Wright Associates Inc (REWI)  
Response Rentals  
Sentex Systems Inc



716-359-1110

Telog Instruments Inc  
Turner Designs

## Insulation, Thermal

Harborite Corp  
Lindberg A General Signal Co  
Marshall Industrial Technologies  
Omega Engineering Inc  
SEE AD ON PAGE 2  
Schuller International Inc

## Insurance

American Safety Risk Retention Group  
Inc  
SEE AD ON PAGE 32



Bonding & Insurance  
ECS Underwriting Inc  
SEE AD ON PAGE 143  
Jardine Insurance Broker LA Inc  
SEE AD ON PAGE 44  
National Association of Self Employed  
United Capitol Insurance Co  
United Environmental Coverage Corp

## Intake Screens

Atlantic Screen & Mfg Inc  
Diversified Well Products Inc  
SEE AD ON PAGE 30

Envirex  
Parkson Corp

## Ion Exchange

Dionex Corp  
Dow Chemical Co, The  
Industrial Filter & Pump Mfg Co  
Ionics Inc  
Mobile Process Technology  
SEE AD ON PAGE 48

Osmonics Inc  
SEE AD ON PAGE 31

Remco Engineering  
Serfilco Ltd  
Smith & Loveless Inc  
Spectrum Medical Industries  
Treatment Technologies  
United States Filter Corp  
Western Filter Co  
Wheelabrator Engineered Systems Inc -  
Mentek Products

## Labeling

Ben Meadows



Computer Allii  
SEE AD ON PAGE 120

Diagraph Corp  
Genium Publishing Corp  
HazWaste Technologies Corp  
Heart Information Systems Inc  
Integrated Software Design Inc  
J J Keller & Associates Inc  
Lab Safety Supply  
Labelmaster  
Legible Sign Inc  
Magid Glove & Safety Mfg Co  
National Marker Co  
Signmark Div/Brady USA Inc  
Ternac Inc/TEMPbadge

## Laboratory Equipment/Supplies

ABB Raymond  
ATI Orion  
Associated Design & Mfg  
B-J Scientific Products Inc  
Barnart Co

Ben Meadows  
 Bioscience Inc  
 CEM Corp  
 CHEMetrics Inc  
 Cole-Parmer Instrument Co  
 Dival Safety Equipment  
**Diversified Well Products Inc**  
**SEE AD ON PAGE 30**  
 ELE International Inc/Soiltest  
 Products Div

**EAGLE P-PICHER**  
**1-800-331-7425**

Eagle-Picher/Env Science & Technology  
 Earth & Atmospheric Sciences Inc  
 Engelhard Corp  
 Entech Instruments Inc  
 Environmental Resource Associates  
 FMI - Fluid Metering Inc  
 Fisher Scientific Safety Products Div  
 G E Co  
 Genium Publishing Corp  
 Glen Mills Inc  
 Gurman Container & Supply Corp  
 Hazco Services Inc  
 Helima

**Horiba Instruments Inc**  
**SEE AD ON PAGE 44**

Innovative Sensors Inc  
 J + W Scientific  
 Justite Mfg Co/Div of Federal Signal Corp  
 Lab Safety Supply  
 Lab-Line Instruments Inc  
 Labonco Corp  
 MKS Instruments Inc  
 Millipore Corp  
 Misonix Inc  
 Monarch Instrument  
 Morehouse-Cowles Inc  
 Naige Co  
 Nesab Instruments Inc  
**New Pig Corp**  
**SEE AD ON PAGE 138**

Nuare Inc  
 Nuclear Associates  
 OI Analytical  
 OSRAM Sylvania Inc  
 Onas Corp  
**Omega Engineering Inc**  
**SEE AD ON PAGE 2**

Orbeco Analytical Systems Inc  
**Osmonics Inc**  
**SEE AD ON PAGE 31**

Perkin-Elmer Corp  
 Perstorp Analytical Inc  
 Phipps & Bird Inc  
 Polyfoam Packers Corp  
 Pope Scientific  
 Rosemont Analytical  
**Safety Storage Inc**  
**SEE AD ON PAGE 70**

Spectronics Corp  
 Spectrum Chemical & Safety Products  
 Structure Probe Inc/SPI Supplies

**Terra Universal, Inc.**  
 Environmental Control Equipment  
**714-526-0100**

Terra Universal  
 Whatman Inc  
 Wheaton Science Products  
 Wilkens-Anderson Co  
 Wonder Makers Inc

**Laboratory Services/Testing**

ACTS Testing Labs Inc  
 AE Environmental Services Inc  
 ASTB Analytical Services Inc  
 ATEC Associates Inc  
 Aaron Environmental Services Corp  
 Accredited Laboratories Inc  
 Advanced Technology Laboratories

American Standards Testing Bureau Inc  
 Applied Research & Development Lab  
 Assay Technology Inc  
 Atlantic Testing Laboratories Limited  
 B & W NESI NEL  
 BEC Laboratories  
 Bailey Controls Co  
 Bioscience Inc  
 Bird Machine Co Inc  
 Braun Intertec Corp  
 Brooklyn Thermometer Co Inc  
 Brown & Root Environmental  
 CET Environmental Services Inc  
 CTL Environmental Services  
 Chester Environmental  
 Clean Air Engineering  
 Clean Venture/Cycle Chem  
 Compu Chem Environmental Corp  
 Con-Test  
 Container Testing Laboratory Inc  
 Covino Environmental Consulting Inc  
 Dames & Moore  
 Detail Associates Inc  
 E S E Bioscience

EA Engineering, Science & Technology Inc  
 ELB & Associates  
 ENSCI Environmental Inc  
 Ekenfelder  
 Eco Tek Laboratory Services Inc  
 Engelhard Corp  
 Entropy Inc  
 Envrte Corp  
 Environmental Products & Services Inc  
 Environvision Group Inc, The  
 Foppe Thelen Group Inc  
 G E Co  
 GTEL Environmental Laboratories  
 Galson Corp

Gannett Fleming Inc  
 Gascoyne Laboratories Inc  
 Genium Publishing Corp  
 GeoSyntec Consultants  
 Global Environmental Inc  
 Gulf States Analytical Inc  
 H E S Inc  
 Hart Crowser Inc  
 Heritage Environmental Services Inc  
 Hill International Inc  
 Huntingdon Engineering & Environmental Inc  
**Lancaster Laboratories Inc**  
**SEE AD ON PAGE 7**

Maxim Engineers Inc  
 Noxso Corp  
 Nytest Environmental Inc  
 Ogdens Environmental & Energy Services  
**Omega Engineering Inc**  
**SEE AD ON PAGE 2**

Pacific Analytical Inc  
 Peoria Disposal Co  
 Professional Analytical & Consulting Services Inc  
 Professional Service Industries Inc  
 R E Wright Associates Inc (REWI)  
 RMT Inc  
 Radian Corp  
 Raytheon Engineers & Constructor/Raytheon Enviro Svc  
 Recon Environmental  
 Resource Consultants Inc  
 Rollins Environmental  
 SSM/Spotts Stevens & McCoy Inc

**Safety-Kleen**  
**1-800-323-5040**

Safety Kleen Corp  
 Spectraserv  
 Structure Probe Inc/SPI Supplies  
 Teledyne Brown Engineering - Environmental Services  
 Terra Bio Chem Environmental & Engineering Services Inc  
 Trans-Enviro Inc  
 Traverse Group, The

Triangle Laboratories Inc  
 Trinity Environmental Technologies  
 Waste Stream Technology Inc  
 Western Filter Co  
 Wonder Makers Inc  
 Yellow Logistics Services Inc

**Lagoon Separators/Baffles**

Environetics Inc  
 MPC Containment System Ltd  
 ModuTank Inc  
 Plastic Fusion Fabricators  
 Sunshine Technology Corp  
 Watersaver Co Inc

**Land Application Equipment**

**ag-chem**  
**612-933-9006**

Ag-Chem Equipment Co  
 A Engineering, Science & Technology Inc  
 Brown Bear Corp  
 Convento Mfg Co Inc  
**Liquid Waste Technology Inc**  
**SEE AD ON PAGE 35**

**Land Application Systems**

**Liquid Waste Technology Inc**  
**SEE AD ON PAGE 35**  
 R E Wright Associates Inc (REWI)  
 Wheelabrator Clean Water Systems  
 Inc/Bio Gro Div

**Landfills**

ATI  
 Atlantic Screen & Mfg Inc  
 BEM Systems Inc  
 Brown & Root Environmental  
**Carylon Corp**  
**SEE AD ON PAGE 66**  
 Clean Environmental Equipment  
 Climatronics Corp  
 Conwed Environmental  
 EA Engineering, Science & Technology Inc  
 EPG Companies Inc  
 ERM-South Inc  
**Ejector Systems Inc**  
**SEE AD ON PAGE 52**

Environmental Protection Inc  
 FBA Environmental Inc  
 Foster Wheeler Environmental Corp  
 Foth & Van Dyke  
 Geo-Technology Associates Inc  
 Hydro-Terra Inc  
 Morrison, Knudsen Corp  
 National Seal Co  
 O'Brien & Gere Technical Services Inc  
 Parsons Engineering Science Inc  
 Peoria Disposal Co  
 QED GroundWater Specialists  
 Rust Environment & Infrastructure  
 Rust International Inc  
 Serrot Corp  
 Sewall, James W Co  
 Smith & Loveless Inc  
 Stanley Consultants Inc  
 Stearns & Wheeler  
 Tenax Corp  
 Zimpro Environmental Inc

**Landfills Equipment**

Aeromix Systems Inc  
 American Gas Products Inc  
 Ameron Fiberglass Pipe Systems  
 Caron Compactor Co  
 Clean Environment Equipment  
 Climatronics Corp

**COLUMBIAN**  
 STEEL TANK COMPANY  
**913-621-3700**

Columbian Steel Tank

**EG&G ROTRON**  
**914-246-3401**

E G & G Rotron - Industrial Div  
 EPG Companies Inc  
 Environmental Protection Inc  
 Finn Corp  
 Forrer Supply Co Inc  
 Hazco Services Inc  
 Integra Plastics Inc  
 J V Mfg Inc/Cram-A-Lot  
 LaBounty Manufacturing Div of Stanley  
 Hydraulic Tools

**Met-Pro Corp Systems Div**  
**SEE AD ON PAGE 43**

Multitek Inc  
 NAO Inc  
 Plexco  
 Portec Construction Equip Div  
 Quality Industries Inc  
 Sensidyne Inc  
 Soil & Material Engineers Inc  
 Watersaver Co Inc

**WHESOE VAREC**  
**714-761-1300**

Whesoe Varec  
 Zink, John Co Div of Koch  
 Engineering Co Inc

**Landfills Services**

ATI  
 AWD Technologies Inc  
 Adirondack Environmental Associates Inc  
 Alliance Environmental Inc  
 Atlantic Testing Laboratories Limited  
 Biasland Bouck & Lee Inc  
 Braun Intertec Corp  
 Brown & Root Environmental  
 Clean Environment Equipment  
 Consulting Environmental  
 Engineerings Inc  
 Dames & Moore  
 EA Engineering, Science & Technology Inc  
 ERM Group, The  
 Enercon Services Inc  
 Enviro-Sciences Inc

**EPOLEON** CORPORATION OF AMERICA  
**1-800-EPOLEON**

**Epoleon Corp of America**  
**SEE AD ON PAGE 24**

FBA Environmental Inc  
 Foppe Thelen Group Inc  
 Foster Wheeler Environmental Corp  
 Geotrans Inc  
 Graef Anhalt Schloemer  
 Groundwater Technician Services Inc  
 Haley & Aldrich Inc  
**Geo-Con Inc**  
**SEE AD ON PAGE 56**  
 Hart Crowser Inc  
 Hayward Baker Environmental  
 Heritage Environmental Services Inc  
 Hill International Inc  
 Hydro Group

**INTERVOG**  
 National Technical Services  
**1-800-433-8487**

IntervaNational Technical Services Inc  
**SEE AD ON PAGE 17**

O'Brien & Gere Technical Services Inc  
 Ogdens Environmental & Energy Services  
 Parsons Engineering Science Inc  
 Peoria Disposal Co  
 R E Wright Associates Inc (REWI)  
 RMT Inc  
 Raytheon Engineers & Constructor/Raytheon Enviro Svc  
 Rust Environment & Infrastructure  
 Rust International Inc  
 SSM/Spotts Stevens & McCoy Inc  
 Severson Environmental Services Inc  
 Sewall, James W Co  
 Stearns & Wheeler  
 Superior Environmental Corp  
 Sverdrup Environmental Inc  
 United States Filter Corp  
 Vamco Engineering Group

**Leachate Treatment**

ATI  
 Aeromix Systems Inc  
 Andco Environmental Processes Inc  
 AquaTec Inc  
 BioTrol Inc  
 Biasland Bouck & Lee Inc  
 Calgon Carbon Corp  
 Clean Environment Equipment  
 Denver Mineral Engineers Inc  
 EA Engineering, Science & Technology Inc

**Ejector Systems Inc**  
**SEE AD ON PAGE 52**

Envirex  
 FBA Environmental Inc  
 Foppe Thelen Group Inc  
 Foster Wheeler Environmental Corp  
 Franco Environmental Technologies  
 Great Lakes Environmental Inc  
 Heritage Environmental Services Inc  
 Horizontal Technologies Inc  
 Hydro Group  
 International Technology Corp  
 Landa Inc

**Met-Pro Corp Systems Div**  
**SEE AD ON PAGE 43**

ModuTank Inc  
**National Technical Systems Inc**  
**SEE AD ON PAGE 17**

O'Brien & Gere Technical Services Inc  
 Parsons Engineering Science Inc  
 Plastic Fusion Fabricators  
 Plexco  
 Pollution Control Inc  
 Prominent Fluid Controls Inc  
 R E Wright Associates Inc (REWI)  
 Raytheon Engineers & Constructor/Raytheon Enviro Svc  
 Reef Industries Inc  
 Remco Engineering  
 Rust Environment & Infrastructure  
 Rust International Inc  
 SSM/Spotts Stevens & McCoy Inc  
 Severson Environmental Services Inc  
 Smith & Loveless Inc

**Spectraserv**  
 Stearns & Wheeler  
 Superior Environmental Corp  
 Sverdrup Environmental Inc  
**Unipure Environmental**  
**SEE AD ON PAGE 10**

United States Filter Corp  
 Waste Stream Technology Inc  
 Water Equipment Tech  
 Wheelabrator Environmental Systems Inc  
 Zimpro Environmental Inc

**Lead Paint Abatement**

AE Environmental Services Inc  
 Aaron Environmental Services Corp  
 CRX Environmental Services Inc  
 Coastwide Environmental Technologies Inc  
 Covino Environmental Consulting Inc

Dames & Moore  
 Dival Safety Equipment  
 EA Engineering, Science  
 & Technology Inc  
 Envirovision Group Inc, The  
 Galson Corp  
 Hill International Inc  
 International Protective Coatings Corp  
 O'Brien & Gere Technical Services Inc  
 PDG Environmental Inc  
 Pentek Inc  
 Professional Service Industries Inc  
 R E Wright Associates Inc (REWI)  
 Recon Environmental  
 Sensidyne Inc  
 Stanley Consultants Environmental Inc  
 Sverdrup Environmental Inc  
 Tank Industry Consultants Inc  
 Terra Bio Chem Environmental &  
 Engineering Services Inc  
 Traverse Group, The  
 Versar Inc  
 Wellington Environmental Consulting &  
 Construction Inc

### Leak Detectors

Airm Safety USA Inc  
 Agar Corp  
 American EnviroSpect Inc  
 Ariel Industries Inc  
 Arizona Instrument Corp



**Air's Manufacturing & Supply (AMS)**  
 SEE AD ON PAGE 53

Babcock & Wilcox  
 Bacharach Inc  
 Bailey-Fischer & Porter Co  
 Bascom-Turner Instruments  
 CEA Instruments  
 Capital Controls Co Inc  
 Chemtrol Div of Nibco Inc  
 Cole-Parmer Instrument Co  
 Control Instruments Corp  
 Cosmos Gas Detection  
 Dival Safety Equipment  
 Dyna-Fid Inc  
 EBW Inc  
 EFA Technologies Inc  
 EIT  
 ENMET Corp  
 EPD Technology Corp  
 Environmental Compliance Systems Corp  
 Ferrick Construction Co Inc  
 Fluid Components Intl  
 Fluoroware  
**Foxboro Co, The**  
 SEE AD ON PAGE 46  
 Gems Sensors Div  
 General Analysis Corp  
 GeoSynTec Consultants  
 Hazzo Services Inc  
**Heath Consultants Inc**  
 SEE AD ON PAGE 142  
 Highland Tank  
 Industrial Scientific Corp  
 Intek Corp/Perit-Alyzer  
 International Sensor Technology  
 Jerman Waterworks Supply  
 Liebert Corp  
 MKS Instruments Inc  
 MSA  
 McNeill International  
 Metrotech Corp  
 Midwesco Filter Resources Inc  
**Milco Safety Rental**  
 SEE AD ON PAGE 64  
 ModuTank Inc  
 National Draeger Inc  
 Neotronics  
 OPW Fueling Components  
**Omega Engineering Inc**  
 SEE AD ON PAGE 2

One Plus Corp - Leak Edge Div  
 Pace Transducer/CJ Enterprise  
 Plastic Fusion Fabricators  
 Response Rentals  
 Ridge Tool Co  
 Sensidyne Inc  
 Sierra Monitor Corp  
 Spectronics Corp  
 Spectrum Chemical & Safety Products  
 Superior Signal Co Inc  
 Swagelok Companies, The



Tracer Research Corp  
 Universal Enterprises Inc  
 Universal Sensors & Devices Inc  
 Varian Instruments  
 Veeder-Root Co  
**Wallace & Tiernan Inc**  
 SEE AD ON PAGE 29

### Level Instrumentation

Agar Corp  
 Atlantic Screen & Mfg Inc  
 Automation Products Inc  
**Badger Meter Inc**  
 SEE AD ON PAGE 4  
 Bailey Controls Co  
 Bailey-Fischer & Porter Co  
 Campbell Scientific Inc  
 Control Electronics Inc  
**Diversified Well Products Inc**  
 SEE AD ON PAGE 30  
 Drexelbrook Engineering Co  
 Dwyer Instruments Inc  
 EIT  
 Fluid Components Intl  
 Gems Sensors Div



Global Water  
 Handlar  
 Harwill Corp  
 Hazzo Services Inc  
 Instruments Direct Inc  
 Invalco Inc  
 Invention Inc  
 MKS Instruments Inc



**MMC Intl Corp**  
 SEE AD ON PAGE 23  
 Mastrr Co, The  
 Metritape Inc  
**Milltronics Inc**  
 SEE AD ON PAGE 16  
 Monarch Instrument  
 Newport Electronics Inc  
**Omega Engineering Inc**  
 SEE AD ON PAGE 2  
 Pace Transducer/CJ Enterprise  
 Sparing Instruments Co Inc  
 Thomas Products Limited  
 Thornton Associates Inc  
 Undata America

### Level, Sight Gauges

Dwyer Instruments Inc  
 Gems Sensors Div  
**Omega Engineering Inc**  
 SEE AD ON PAGE 2  
 Thomas Products Limited

### Lift Stations

Disclco Corp  
 Marshall Industrial Technologies

Moran Manufacturing Inc  
 Smith & Loveless Inc

### Lime Slakers

Smith & Loveless Inc  
**Wallace & Tiernan Inc**  
 SEE AD ON PAGE 29  
 Zimpro Environmental Inc

### Liners

Acme Container Co  
 Advanced Polymer Sciences Inc



Amfue!  
 Bixby International Corp  
 Claymax Corp  
**Diversified Well Products Inc**  
 SEE AD ON PAGE 30  
 Environmental Industrial Resources  
 Environmental Protection Inc



**Fabricco Environmental Liners Inc**  
 SEE AD ON PAGE 32  
**Geo-Con Inc**  
 SEE AD ON PAGE 54

Gundie Lining Systems Inc  
 Gurman Container & Supply Corp  
 Hazzo Services Inc  
 Horizontal Technologies Inc  
 Integra Plastics Inc  
 JPS Elastomerics Corp  
 Labelmaster  
 MPC Containment System Ltd  
 ModuTank Inc  
 National Seal Co  
 Packaging Research & Design  
 R E Wright Associates Inc (REWI)  
 Reef Industries Inc



Sentry Polymers Inc  
 Serrot Corp  
 Watersaver Co Inc

### Liquid Extractors



Amfue!  
 Baler Equipment Co  
**Diversified Well Products Inc**  
 SEE AD ON PAGE 30  
 Hazzo Services Inc  
 Misonix Inc  
 Tedder & Widhelm Consultants Inc

### Locators, Pipe/Valve/Cable

Ditch Witch  
 Environmental Industrial Resources  
 GeoSynTec Consultants  
 Geophysical Survey Systems Inc  
 Hazzo Services Inc  
**Heath Consultants Inc**  
 SEE AD ON PAGE 142  
 Metro Tel Corp  
 Metrotech Corp  
 Reef Industries Inc  
 Schonstedt Instrument Co

### Make-up Air System

Duall Div Met-Pro Corp  
 Hartzell Fan Inc  
 JBI Spray Booth Systems  
 Winsor & Jerault

### Management Services

A M A R C Inc (AIHMM)  
 AWD Technologies Inc  
 Alton Geoscience  
 Arthur D Little Inc  
 BEM Systems Inc  
 C2T Group Ltd  
 Center for Hazardous Materials Research



**Computer AIII**  
 SEE AD ON PAGE 120

ERM Group, The  
 ERM-South Inc  
 Envires Corp  
 Enviro-Sciences Inc  
 Environmental Standards Inc  
 FBA Environmental Inc  
 Foster Wheeler Environmental Corp  
 Geotrans Inc  
 Graef Anhalt Schloemer  
 Hill International Inc  
 Kinane Engineering  
 L Robert Kimball & Associates  
 LEXICON Environmental Associates Inc



Morrison, Knudsen Corp  
 NST Engineers  
 Natisco  
 Occupational Health & Hygiene Corp of  
 America  
 Ogden Environmental & Energy Services  
 R E Wright Associates Inc (REWI)  
 RMT Inc  
 Radian Corp  
 Raytheon Engineers &  
 Constructor/Raytheon Enviro Svc  
 Rust Environment & Infrastructure  
 Rust International Inc  
 Sverdrup Environmental Inc  
 TRAK Environmental Group Inc  
 Terra Bio Chem Environmental &  
 Engineering Services Inc

### Manometers

CAE Express  
 Dival Safety Equipment  
 Dwyer Instruments Inc  
 Hazzo Services Inc  
 M-Tec Corp  
 Neotronics  
 Pace Transducer/CJ Enterprise

### Medical Waste Disposal

ABB Raymond  
 BBS Sanitex  
 AE Environmental Services Inc  
**Eco Waste Solutions**  
 SEE AD ON PAGE 55  
 EnerWaste Intl Corp  
 Gelco Intl Corp  
 Lincoln Automotive  
 Traverser Group, The

### Mercury Instruments

Ariel Industries Inc  
 Arizona Instrument Corp  
 Bacharach Inc  
 Dival Safety Equipment  
 Hazzo Services Inc

Novalynx Corp  
 Spectrogram Corp

### Mercury Spill Cleanup Products

Central Environmental Inc  
 Denver Mineral Engineers Inc  
 Dival Safety Equipment  
 Fisher Scientific Safety Products Div  
 Hazzo Services Inc  
 JT Baker Chemical Inc  
 Lab Safety Supply  
**New Pig Corp**  
 SEE AD ON PAGE 138  
 Spectrum Chemical & Safety Products  
 Vac-U-Max  
 Vacuum Engineering  
 Vector Technologies Ltd

### Metal Recovery Systems

ABB Raymond  
 College Research Corp (CORECO)  
 Denver Mineral Engineers Inc  
 Engelhardt Corp  
 Environmental Basics Co  
 General Kinematics Corp  
 Heritage Environmental Services Inc  
**Met-Pro Corp Systems Div**  
 SEE AD ON PAGE 43  
 Remco Engineering  
 Serflico Ltd  
 United States Filter Corp  
 Vac-U-Max

### Meteorological

A I W Inc  
 Aanderaa Instruments Inc  
 Air Resource Specialists Inc  
 Air Science Consultants  
 Campbell Scientific Inc  
 Center for Hazardous Materials Research  
 Climatronics Corp  
 Coastal Environmental Systems  
 Coastal Leasing Inc  
 Dames & Moore  
 Dwyer Instruments Inc  
 ELE International Inc/Soiltest  
 Products Div  
 Earth & Atmospheric Sciences Inc  
 Global Water



H2NS Environmental  
 Handlar  
 Hans Environmental Inc  
**Met-One Instruments Inc**  
 SEE AD ON PAGE 26  
 Novalynx Corp  
 Qualimetrix Inc  
**R M Young Co**  
 SEE AD ON PAGE 47

Raytheon Engineers &  
 Constructor/Raytheon Enviro Svc  
 Solomat  
 Sonoma Technology Inc  
 Stanley Consultants Inc  
 Vaisala Inc  
 Vitel Inc

### Meters

**Badger Meter Inc**  
 SEE AD ON PAGE 4  
 Bailey Controls Co  
 Bailey-Fischer & Porter Co  
 Barnart Co  
 Ben Meadows  
 CAE Express  
 Clean Air Engineering  
 Cole-Parmer Instrument Co  
 Data Industrial Corp



Dickson Co, The  
**Dieterich Standard, a Dover Industries Co**

**SEE AD ON PAGE 64**

Dival Safety Equipment  
Dynamason Inc  
ELE International Inc/Soiltest Products Div  
EPG Companies Inc  
Engelhard Corp  
Fluid Components Intl  
GeoSyntec Consultants  
HNU Systems Inc  
Hazco Services Inc  
Hersey & Measurement  
**Horiba Instruments Inc**

**SEE AD ON PAGE 44**

ISTA Energy Systems Corp  
Innovative Sensors Inc  
Instruments Direct Inc  
Jerman Waterworks Supply  
Lamson Corp  
**Miltronics Inc**

**SEE AD ON PAGE 16**

Monarch Instrument  
Myron L Co  
Newport Electronics Inc  
NovaLynx Corp  
Nuclear Associates  
**Omega Engineering Inc**  
**SEE AD ON PAGE 2**  
Orbeco Analytical Systems Inc  
Simpson Electric Co  
Spectronics Corp  
Taylor Technologies  
Terra Universal  
Thornton Associates Inc  
Universal Enterprises Inc



**209-784-3544**

Water Specialties Corp  
Wavetek Corp

**Mist Eliminators/Collectors**

Advanced Industrial Technology Corp  
Aerology Inc  
Aget Manufacturing Co  
Air Plastics Inc  
Airotech  
Anderson 2000 Inc  
CMI-Schneible Co  
CVM Corp



**516-467-1600**

Clean Gas Systems Inc  
Dual Div Met-Pro Corp  
Ducon Environmental Systems Inc  
Dustvent Inc



**914-246-3401**

E G & G Rotron - Industrial Div  
EPG Companies Inc  
Hazco Services Inc  
Hyde Products Inc  
Jaeger Products Inc  
Koch Engineering Co Inc  
Micro Air, Air Cleaners by Metal-Fab Inc



**314-275-5700**

Monsanto Enviro-Chem  
Morlan & Morlan Inc  
National Environmental Systems Inc  
Norton Chemical Process Products Corp

Wheelabrator Environmental Systems Inc

**Mixers**

ARDE Barinco Inc  
Aeromix Systems Inc  
Aqua Tech Industries Inc  
Associated Design & Mfg  
Baker Tanks  
Barnart Co  
Brown Bear Corp  
Capital Controls Co Inc  
Chemineer Inc  
Cole-Parmer Instrument Co  
ELE International Inc/Soiltest Products Div  
EMI Inc Eastern-Cleveland Mixers  
Entoliter Inc  
Glen Mills Inc  
Koch Engineering Co Inc  
Lab-Line Instruments Inc  
**Liquid Waste Technology Inc**

**SEE AD ON PAGE 35**

Mastrri Co, The  
Measurement & Flow Control  
Morehouse-Cowles Inc  
National Bulk Equipment Inc  
Neptune Chemical Pump Co  
Pope Scientific  
Portec Construction Equip Div  
Robbins & Myers Inc/Moyno Industrial Products Div  
Serfilco Ltd  
Smith & Loveless Inc  
Universal Process Equipment Inc  
Zimmerman Industries Inc

**Mobile Labs**

AWD Technologies Inc  
Aaron Environmental Services Corp  
Atlantic Testing Laboratories Limited  
Brown & Root Environmental  
EA Engineering, Science & Technology Inc  
Eco Tek Laboratory Services Inc  
Entropy Inc  
Environmental Technologies Group  
GTEL Environmental Laboratories  
Gascogne Laboratories Inc  
Global Environmental Inc  
Hart Crowser Inc  
Hazco Services Inc  
International Sensor Technology  
Medical Coaches  
Professional Analytical & Consulting Services Inc  
R E Wright Associates Inc (REWI)  
Traverse Group, The

**Vertek**

**SEE AD ON PAGE 61**

**Moisture Instrumentation**

ATI Orion  
Ametek Inc  
Ametek P & AI Div  
Anarad Inc  
Ariel Industries Inc  
Arizona Instrument Corp  
CAE Express  
CEM Corp  
Campbell Scientific Inc  
Clean Air Engineering  
**Colog Inc**

**SEE AD ON PAGE 32**

Dickson Co, The  
Dival Safety Equipment  
ELE International Inc/Soiltest Products Div  
Engelhard Corp  
Epic Inc  
Hazco Services Inc  
Keoc R & D Inc  
Newport Electronics Inc  
NovaLynx Corp

Ohaus Corp  
**Omega Engineering Inc**  
**SEE AD ON PAGE 2**

Parametrics PCI Div  
Teledyne Brown Engineering/Analytical Instruments  
Vaisala Inc

**Monitoring Systems, Air**

A I W Inc  
AWD Technologies Inc  
Advanced Control Systems  
Air Instruments & Measurements Inc  
Air Metrics  
Air Monitor Corp  
Air Resource Specialists Inc  
Airscon Environmental Technologies Inc  
Alnor Instrument Co  
Alton Geoscience  
Ametek Inc  
Ametek P & AI Div  
Anarad Inc



**918-662-7343**

**Applied Automation/Hartman & Braun**  
**SEE AD ON PAGE 164**

Assay Technology Inc  
Atlantic Testing Laboratories Limited  
**Auburn International Inc**  
**SEE AD ON PAGE 53**

Bacharach Inc  
Bascom-Turner Instruments  
Ben Meadows  
Bios Intl  
Biosystems  
Bruel & Kjaer Instruments  
Burns & McDonnell  
CAE Instrument Rental  
CEA Instruments  
Campbell Scientific Inc  
Clean Air Engineering  
Climatronics Corp  
Coastal Environmental Systems  
Columbia Science Industries Co  
Columbia Scientific  
Control Instruments Corp  
Cosmos Gas Detection  
Dancoer Communications Inc  
Dasibi Environmental Corp  
Dickson Co, The  
Dival Safety Equipment  
Dwyer Instruments Inc  
Dyna-Fid Inc  
ELE International Inc/Soiltest Products Div  
ENMET Corp  
ERM Group, The  
ERM-South Inc  
Engelhard Corp  
Entech Instruments Inc  
Environmental Compliance Systems Corp  
Environmental Energy Services Inc (EES)  
Environmental Health & Engineering Inc  
Environmental Monitor Systems Inc  
Environmental Products & Services Inc  
Environmental Technologies Group



**201-994-2300**

Enviroplan Inc  
Fluid Components Intl  
Fluid Data Inc  
General Analysis Corp  
HNU Systems Inc  
Handar  
Hazco Services Inc  
Heritage Environmental Services Inc  
**Horiba Instruments Inc**  
**SEE AD ON PAGE 44**  
Hull Corp Environmental Products Div

Intotec Inc  
Intec Controls Corp  
International Sensor Technology  
LING Quantum Analytics  
Lab Safety Supply  
Lamson Corp  
Liebert Corp  
MKS Instruments Inc  
MSA  
McNeill International  
**Met-One Instruments Inc**  
**SEE AD ON PAGE 26**

Midac Corp  
Monarch Instrument  
Monitor Labs Inc  
Morrison, Knudsen Corp  
NovaLynx Corp  
Ntron Inc, A Neutronics Co  
Nuclear Associates  
OI Analytical



**512-834-4141**

Odessa Engineering  
**Omega Engineering Inc**  
**SEE AD ON PAGE 2**

Oxford Environmental Inc  
PACE Environmental Products  
Parametrics PCI Div  
Perkin-Elmer Corp  
**Photovac Monitoring Instruments**  
**SEE AD ON PAGE 42**

R E Wright Associates Inc (REWI)  
Radian Corp  
Recon Environmental  
Rosemount Analytical Inc  
Rust Environment & Infrastructure  
Rust International Inc  
Scott Aviation, A Figgie Intl Co  
Sensidyne Inc  
Sentex Systems Inc  
Servomex Co Inc  
Sierra Monitor Corp  
Sixnet  
Solomat  
Sonoma Technology Inc  
Superior Signal Co Inc  
TSI Inc/Environmental Measurements & Controls Div  
Teledyne Brown Engineering - Control Applications  
Terra Bio Chem Environmental & Engineering Services Inc  
Trinity Consultants Inc  
United Sciences Inc  
Universal Enterprises Inc  
Universal Sensors & Devices Inc  
Vaisala Inc  
Wheelabrator Environmental Systems Inc  
Zink, John Co Div of Koch Engineering Co Inc

**Monitoring Systems, Hazardous Material**

A I W Inc  
AWD Technologies Inc  
Alton Geoscience  
American Scientific Instrumentation  
Atlantic Testing Laboratories Limited  
**Auburn International Inc**  
**SEE AD ON PAGE 53**  
Bran & Luebbe Inc  
Burns & McDonnell  
Civacon-Dover Resources  
Control Instruments Corp  
Dival Safety Equipment  
**Diversified Well Products Inc**  
**SEE AD ON PAGE 30**  
Dyna-Fid Inc  
E S E Bioscience  
EBW Inc  
ENMET Corp  
ERM Group, The

ERM-South Inc  
Engelhard Corp  
Environmental Monitor Systems Inc  
Environmental Products & Services Inc  
HNU Systems Inc  
Hazco Services Inc  
Heritage Environmental Services Inc  
Intec Controls Corp  
International Sensor Technology  
Invention Inc  
Keoc R & D Inc  
Kennedy/Jenks Consultants  
LING Quantum Analytics  
Lab Safety Supply  
**Miltronics Inc**  
**SEE AD ON PAGE 16**

Monarch Instrument  
Nuclear Associates  
Oxford Environmental Inc  
Perkin-Elmer Corp  
**Photovac Monitoring Instruments**  
**SEE AD ON PAGE 42**

R E Wright Associates Inc (REWI)  
Rust Environment & Infrastructure  
Rust International Inc  
Sensidyne Inc  
Sentex Systems Inc  
Servomex Co Inc  
Sierra Monitor Corp  
Traverse Group, The  
Universal Sensors & Devices Inc

**Monitoring Systems, Water**

A I W Inc  
ADS Environmental Services Inc  
ATI  
ATI Orion  
AWD Technologies Inc  
Adronadack Environmental Associates Inc  
Advanced Control Systems  
Alliance Environmental Inc  
Alton Geoscience  
Ametek P & AI Div



**918-662-7343**

**Applied Automation/Hartman & Braun**  
**SEE AD ON PAGE 164**



**1-800-635-7330**

**Art's Manufacturing & Supply (AMS)**  
**SEE AD ON PAGE 53**

Associated Design & Mfg  
Atlantic Screen & Mfg Inc  
Atlantic Testing Laboratories Limited  
Automation Products Inc  
Bailey-Fischer & Porter Co  
Ben Meadows  
Bran & Luebbe Inc  
Burns & McDonnell  
CHEMetrics Inc  
Campbell Scientific Inc  
Capital Controls Co Inc  
Coastal Leasing Inc  
Consulting Environmental Engineering Inc  
Control Instruments Corp  
Dancoer Communications Inc



**1-800-765-3473**

Detector Electronics Corp  
Dickson Co, The  
**Diversified Well Products Inc**  
**SEE AD ON PAGE 30**  
ELE International Inc/Soiltest Products Div

ENMET Corp  
ERM Group, The  
Environmental Products & Services Inc  
**Environmental Restoration Systems Inc**  
SEE AD ON PAGE 18

Geoguard Inc  
Global Water  
H F Scientific Inc  
HNU Systems Inc  
Handar  
Hazco Services Inc  
Heritage Environmental Services Inc  
**Horiba Instruments Inc**  
SEE AD ON PAGE 44

**Hydrolab Corp**  
SEE AD ON PAGE 22

Intec Controls Corp  
Invalco Inc  
Inventron Inc  
Isco Inc Environmental Div  
Kaye Instruments Inc  
Keco R & D Inc  
Kennedy/Jenks Consultants  
Lab Safety Supply  
Liebert Corp  
Microbics Corp  
**Miltronics Inc**  
SEE AD ON PAGE 16

Monarch Instrument  
Myron L Co  
Norris Technologies Inc  
NovaLynx Corp  
OI Analytical  
Oxford Environmental Inc  
Panametrics PCI Div  
Perkin-Elmer Corp  
Progressive Equipment Corp  
R E Wright Associates Inc (REWI)  
Recon Environmental  
Rochester J L Co  
Rust Environment & Infrastructure  
Rust International Inc  
Schneider Instrument Co  
Sensidyne Inc  
Sentex Systems Inc  
Sixnet  
Solomat  
Spectrogram Corp  
Thornton Associates Inc  
Trilogy Controls Inc  
Turner Designs  
Unidata America  
Universal Sensors & Devices Inc  
YSI Inc

**Motor Controllers**

ANVIC Controls  
Advanced Control Systems  
Boston Gear  
**Diversified Well Products Inc**  
SEE AD ON PAGE 30

EPG Companies Inc  
**Environmental Restoration Systems Inc**  
SEE AD ON PAGE 18

G E Co  
H2 Oil Recovery Equipment Inc  
Marshall Industrial Technologies  
Moran Manufacturing Inc  
Newport Electronics Inc  
**Omega Engineering Inc**  
SEE AD ON PAGE 2  
Rhombus Technology  
Time Mark Corp

**Motors**

Boston Gear  
Brailsford & Company  
Cole-Parmer Instrument Co  
**Diversified Well Products Inc**  
SEE AD ON PAGE 30  
EPG Companies Inc  
G E Co  
Marshall Industrial Technologies

RJ Industries Inc  
Reliance Electric Co  
Sew Eurodrive  
Universal Enterprises Inc  
Universal Process Equipment Co  
Westinghouse Motor Co

**Nitrogen Oxide Detectors**

AIM Safety USA Inc  
Air Instruments & Measurements Inc  
Ametek Inc  
Anarad Inc  
Bacharach Inc  
Biosystems  
CEA Instruments  
California Analytical Instruments Inc  
Clean Air Engineering  
Climatronics Corp  
Columbia Science Industries Co  
Columbia Scientific  
Control Instruments Corp  
Dasibi Environmental Corp  
Dival Safety Equipment  
ENMET Corp  
**Energy Efficiency Systems Inc**  
SEE AD ON PAGE 11

Engelhard Corp  
Environmental Compliance Systems Corp  
Environmental Monitor Systems Inc  
Environmental Technologies Group  
Fisher Scientific Safety Products Div  
Hazco Services Inc  
Industrial Scientific Corp  
Intek Corp/Rent-Alyzer  
International Sensor Technology  
Laudauer Inc  
McNeil International  
Monitor Labs Inc  
National Draeger Inc  
Nova Analytical Systems Inc  
Rosenmount Analytical Inc  
Sensidyne Inc  
Servomex Co Inc  
Siemens Industrial Automation Inc  
Sierra Monitor Corp  
Thermo Environmental Instruments  
Wheelabrator Environmental Systems Inc

**Noise Deadening Supplies**

BRD Noise & Vibration Control Inc  
Dival Safety Equipment  
MSA  
Martin Engineering  
**New Pig Corp**  
SEE AD ON PAGE 138  
United McGill Corp

**Noise/Sound Instruments**

BRD Noise & Vibration Control Inc  
Ben Meadows  
Bruei & Kjaer Instruments  
Campbell Scientific Inc  
Cole-Parmer Instrument Co  
Dival Safety Equipment  
ELB & Associates  
Fisher Scientific Safety Products Div  
Hazco Services Inc  
Intek Corp/Rent-Alyzer  
Metrosonics Inc  
Simpson Electric Co  
Universal Enterprises Inc

**Nozzles**

Bete Fog Nozzle Inc  
Bonide Products Inc



Clean Gas Systems Inc  
EIMCO Process Equipment Co  
Fluidyne Corp

NAO Inc  
OPW Fueling Components  
Spraying Systems Co

**Nuclear Waste Handling Equipment**

AAF International  
ABB Raymond  
ARD Environmental Inc  
Automation Products Inc  
Bes-Pac Inc  
DeMarco MAX VAC Corp  
Dival Safety Equipment  
Inventron Inc  
Newage Industries  
Nuclear Associates  
Pentek Inc  
Reef Industries Inc  
S & G Enterprises Inc  
**Safety Storage Inc**  
SEE AD ON PAGE 70  
Skolnik Industries Inc  
Ultradex International  
Vac-U-Max  
Vacuum Engineering  
Vector Technologies Ltd

**Oceanographic Equipment**

Aanderaa Instruments Inc  
Coastal Environmental Systems  
Coastal Leasing Inc  
EG & G Marine Instruments  
R M Young Co  
SEE AD ON PAGE 47

**Odor Control Equipment**

A-Odomaster  
**ABB Air Preheater Inc**  
SEE AD ON PAGE 141

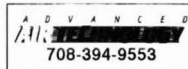

Advanced Air Tech Inc  
Advanced Industrial Technology Corp  
**Advest Technologies Inc**  
SEE AD ON PAGE 36  
Aerology Inc  
Air Plastics Inc  
Airex Div Advest Technologies  
Ambient Engineering Inc  
American Environmental International Inc  
Anderson 2000 Inc  
Anguil Environmental Systems Inc  
Atlantic Ultraviolet Corp



Bohn Biofilter Corp  
CSM Environmental Systems Inc  
CVM Corp  
Calgon Carbon Corp  
Capital Controls Co Inc  
Carbtrol Corp  
Climatronics Corp  
Croll Reynolds Co Inc  
Dual Div Met-Pro Corp  
Ducon Environmental Systems Inc  
Dustvent Inc  
Engelhard Corp  
General Carbon Corp  
Grace TEC Systems  
**Health Consultants Inc**  
SEE AD ON PAGE 142  
ILC Dover Inc  
Johnson Matthey Env  
MICOX Corp  
Micro Air, Air Cleaners by Metal-Fab Inc  
Misonix Inc  
Monroe Environmental Corp

NAO Inc



NuTech Environmental Corp  
Odor Management Inc  
**Osmonics Inc**  
SEE AD ON PAGE 31  
Oxford Environmental Inc



Ozonair Intl Corp  
Ozone Research & Equipment Corp An  
Pepon Systems Inc  
Plexco  
ProMinent Fluid Controls Inc  
Purus Inc  
Reef Industries Inc  
Ross Air Systems  
**Salem Engelhard**  
SEE AD ON PAGE 119

Sensidyne Inc  
Smith & Loveless Inc  
Spectraserv  
Superior Signal Co Inc  
Surco Products Inc  
Telkamp Systems Inc  
Tri-Mer Corp  
Turner EnviroLogic Inc



Unisorb Corp  
Winsor & Jerauld

**Odor Control Treatment**

A-Odomaster  
Baclera Concepts Inc  
Calgon Carbon Corp  
Capital Controls Co Inc  
Carbtrol Corp  
Center for Hazardous Materials Research  
Chemical Lime Co



Clean Gas Systems Inc  
Dual Div Met-Pro Corp  
Ducon Environmental Systems Inc



**Epoleon Corp of America**  
SEE AD ON PAGE 24  
General Carbon Corp  
Gran-Tenesso Resources Inc  
Hill Manufacturing Co Inc  
Landa Inc  
MMT Environmental Services Inc  
Medina Agriculture Products Co Inc



Monsanto Enviro-Chem  
Nalco Chemical Co  
Northwestern Carbon  
O'Brien & Gere Technical Services Inc  
Odor Management Inc  
**Osmonics Inc**  
SEE AD ON PAGE 31  
Oxford Environmental Inc  
Ozone Research & Equipment Corp An  
Parsons Engineering Science Inc

Pepcon Systems Inc  
Peroxidation Services Inc  
R E Wright Associates Inc (REWI)  
RMT Inc  
Remedial Systems Inc  
Revere Products Inc  
Surco Products Inc  
Sverdrup Environmental Inc  
Wheelabrator Environmental Systems Inc

**Oil Skimmers**

AFL Industries Inc  
Agar Corp  
Atlantic Screen & Mfg Inc  
Ben Meadows  
Clean Environment Equipment  
Dival Safety Equipment  
EPG Companies Inc  
Envirex  
Environmental Fuel Systems Inc  
Environmental Industrial Resources  
Environmental Recovery Resources Inc  
**Environmental Restoration Systems Inc**  
SEE AD ON PAGE 18

Franco Environmental Technologies  
H2 Oil Recovery Equipment Inc  
Highland Tank  
Hudson Industries  
Hyde Products Inc  
Labelmaster  
**Liquid Waste Technology Inc**  
SEE AD ON PAGE 35  
**Met-Pro Corp Systems Div**  
SEE AD ON PAGE 43  
Monroe Environmental Corp  
**New Pig Corp**  
SEE AD ON PAGE 138

ORS Environmental Systems  
Oil Skimmers Inc  
Price-Darnall Inc of Alabama  
Quality Industries Inc  
R E Wright Associates Inc (REWI)  
Sericlo Ltd  
Smith & Loveless Inc  
Sunshine Technology Corp  
Tenco Hydro Inc  
Vac-U-Max

**Oil Spill Control Equipment/Services**

AE Environmental Services Inc  
AFL Industries Inc  
ARD Environmental Inc  
Adronack Environmental Associates Inc  
Atlantic Testing Laboratories Limited  
Baker Tanks  
Bixby International Corp  
C2T Group Ltd  
CHEM-Tel Inc  
Carylon Corp  
SEE AD ON PAGE 66

Clean Environment Equipment  
Clean Venture/Cycle Chem  
Dames & Moore  
DeMarco MAX VAC Corp  
Discflo Corp  
Dival Safety Equipment  
Environmental Container Corp  
Environmental Industrial Resources  
Environmental Products & Services Inc  
Environmental Recovery Resources Inc  
**Environmental Restoration Systems Inc**  
SEE AD ON PAGE 18

Foster Wheeler Environmental Corp  
G O Environment Inc  
Godwin Pumps of America Inc  
Hart Crowsier Inc  
Heritage Environmental Services Inc  
Hudson Industries  
Hyde Products Inc  
Labelmaster  
National Environmental Systems Inc  
Nautus Inc

**New Pig Corp**

SEE AD ON PAGE 138

O'Brien & Gere Technical Services Inc  
Ogden Environmental & Energy Services  
Oil Skimmers Inc  
Price-Darnall Inc of Alabama  
R E Wright Associates Inc (REWI)  
Rust Environment & Infrastructure  
Rust International Inc  
Spectrogram Corp  
Spectrum Chemical & Safety Products  
Stearns & Wheeler  
Sunshine Technology Corp  
Ultratech International  
Wolfco Group Inc

Hyde Products Inc  
International Technology Corp  
Joseph Marketing  
Krebs Engineers  
Landa Inc  
McTighe Industries Inc  
Monarch Separators Inc  
Monroe Environmental Corp  
Nalco Chemical Co  
National Environmental Systems Inc  
Nautus Inc  
O'Brien & Gere Technical Services Inc  
ORS Environmental Systems  
Oil Skimmers Inc  
Osmonics Inc

SEE AD ON PAGE 31

Owens Corning  
**Parker Hannifin Corp**

SEE AD ON PAGE 144

Pollution Control Inc  
Power Plant Services  
Price-Darnall Inc of Alabama  
Quality Industries Inc  
R E Wright Associates Inc (REWI)  
RGF Environmental Systems Inc  
Remedial Systems Inc  
Serfilco Ltd  
Sharples, Business Unit of Alfa Laval  
Separation  
Smith & Loveless Inc  
Stockhausen  
Tenco Hydro Inc  
Treatment Technologies  
United States Filter Corp  
Wheelabrator Environmental Systems Inc  
Wheelabrator Environmental Systems Inc  
Wolfco Group Inc

**Oil/Water Monitors**

Adirondack Environmental Associates Inc  
Agar Corp  
Atlantic Screen & Mfg Inc  
Automation Products Inc  
ELE International Inc/Soiltest Products Div  
Ensys Environmental Products Inc  
Environmental Products & Services Inc  
Fluid Components Intl  
General Analysis Corp  
H F Scientific Inc



Hach Co  
Hazo Services Inc  
Highland Tank  
**Horiba Instruments Inc**  
SEE AD ON PAGE 44  
LINC Quantum Analytics  
Monarch Instrument  
ORS Environmental Systems  
Spectrogram Corp  
Teledyne Brown Engineering/Analytical Instruments  
Turner Designs

**Oil/Water Separation**



AFL Industries Inc  
ATI  
AWD Technologies Inc  
Adirondack Environmental Associates Inc  
Alar Engineering Corp  
American EnviroSpect Inc  
Beko Condensate Systems Corp  
Biomin Inc  
Brown Minneapolis Tank  
Carbonair Environmental Systems  
Carbtrol Corp  
Clean Environment Equipment  
Denver Mineral Engineers Inc  
Disflo Corp  
Ducon Environmental Systems Inc  
EIMCO Process Equipment Co  
EPG Companies Inc  
**Ejector Systems Inc**  
SEE AD ON PAGE 52  
Envirex  
Environmental Products & Services Inc  
Environmental Recovery Resources Inc  
**Environmental Restoration Systems Inc**

SEE AD ON PAGE 18

Ferriq Construction Co Inc  
Fluidyne Corp  
Gelok Intl Corp  
GeoPure Continental Systems & Services  
Great Lakes Environmental Inc  
H2 Oil Recovery Equipment Inc  
Heritage Environmental Services Inc  
Highland Tank  
Horner Creative Products Inc  
Hudson Industries

**Opacity**

Air Instruments & Measurements Inc  
Bailey Controls Co  
CAE Instrument Rental  
Columbia Scientific  
Datatest Corp  
Eastern Technical Associates  
Environmental Compliance Systems Corp  
Environmental Techniques  
Midwestco Filter Resources Inc  
Raytheon Engineers & Constructors/Raytheon Enviro Svc  
Rosemount Analytical Inc  
SSM/Spotts Stevens & McCoy Inc  
Tollkamp Systems Inc  
Turner EnviroLogic Inc  
Winsor & Jerauld

**Operation & Maintenance Services**

Alton Geoscience  
Brown & Root Environmental  
Capital Controls Co Inc  
ERM Group, The  
ERS Services  
Environmental Techniques  
FBA Environmental Inc  
Foppe Thelen Group Inc  
Foster Wheeler Environmental Corp  
Geotrans Inc  
Graef Anhalt Schloemer  
H2 Oil Recovery Equipment Inc  
Hart Crowser Inc  
Keating Environmental Management Inc  
Kennedy/Jenks Consultants  
Marshall Industrial Technologies  
Parsons Engineering Science Inc  
R E Wright Associates Inc (REWI)  
RMT Inc  
Raytheon Engineers & Constructors/Raytheon Enviro Svc  
Rust Environment & Infrastructure  
Rust International Inc  
Sverdrup Environmental Inc  
TRAK Environmental Group Inc

Wheelabrator Environmental Systems Inc

**ORP Instrumentation**

Bailey Controls Co  
Ben Meadows  
Capital Controls Co Inc  
Cole-Parmer Instrument Co  
Geoguard Inc  
George Fischer Inc  
H F Scientific Inc

**Horiba Instruments Inc**

SEE AD ON PAGE 44

**HydroLab Corp**

SEE AD ON PAGE 22

Innovative Sensors Inc  
Newport Electronics Inc



Ozonair Intl Corp  
ProMinent Fluid Controls Inc  
SWAN/Industries Analytics  
Schneider Instrument Co  
Serfilco Ltd  
Solomat

**Oxidizers**

**ABB Air Preheater Inc**  
SEE AD ON PAGE 141  
**Adwest Technologies Inc**  
SEE AD ON PAGE 36  
Airex Div Adwest Technologies  
American Environmental International Inc  
Anderson 2000 Inc  
Anguil Environmental Systems Inc  
CET Environmental Services Inc  
CVM Corp  
College Research Corp (CORECO)



Durr Industries Inc  
EPG Companies Inc  
**Eco Waste Solutions**  
SEE AD ON PAGE 55  
Engelhard Corp  
Falmouth Products  
Feco Engineered Systems Inc  
Glenro Inc  
Grace TEC Systems  
H2 Oil Recovery Equipment Inc  
JBI Spray Booth Systems  
Johnson Matthey Env  
MMT Environmental Services Inc  
**Met-Pro Corp Systems Div**  
SEE AD ON PAGE 43



Monsanto Enviro-Chem



Ozonair Intl Corp  
Remedial Systems Inc  
Ross Air Systems



**Salem Engelhard**  
SEE AD ON PAGE 119  
Stanley Consultants Inc



Surface Combustion Inc  
Tollkamp Systems Inc  
Turner EnviroLogic Inc  
**Unipure Environmental**  
SEE AD ON PAGE 10

United McGill Corp  
Winsor & Jerauld  
Wolverine (Massachusetts) Corp  
Zink, John Co Div of Koch Engineering Co Inc

**Oxygen Detectors**

Air Instruments & Measurements Inc  
Ametek Inc  
Bacharach Inc  
Bailey Controls Co  
Bascom-Turner Instruments  
Ben Meadows  
Biosystems  
CEA Instruments  
CHEMetrics Inc  
California Analytical Instruments Inc  
Clean Air Engineering  
Cole-Parmer Instrument Co  
Columbia Scientific



Control Instruments Corp  
Cosmos Gas Detection



Detector Electronics Corp  
Dival Safety Equipment  
EIT  
ENMET Corp  
Fisher Scientific Safety Products Div



Gas Tech Inc  
General Monitors



Hach Co  
Hazo Services Inc  
**Heath Consultants Inc**  
SEE AD ON PAGE 142

Industrial Scientific Corp  
Intek Corp/Ident-Alyzer  
International Sensor Technology  
LINC Quantum Analytics  
Liton



**M.M.C. Intl Corp**  
SEE AD ON PAGE 23

MSA  
McNeill International  
Metrosonics Inc  
National Draeger Inc  
Neotronics  
Nova Analytical Systems Inc  
Ntron Inc, A Neutronics Co  
Response Rentals  
Rosemount Analytical Inc  
Scott Aviation, A Figgie Intl Co  
Sensidyne Inc

Sensor Electronics Corp  
Servomex Co Inc  
Siemens Industrial Automation Inc  
Sierra Monitor Corp  
Solomat  
Spectrum Chemical & Safety Products  
Teledyne Brown Engineering/Analytical Instruments

**Ozonators**

AirSep Corp  
Capital Controls Co Inc  
Dasibi Environmental Corp  
Ducon Environmental Systems Inc  
**Osmonics Inc**

SEE AD ON PAGE 31

Oxford Environmental Inc  
Ozone Research & Equipment Corp An  
ProMinent Fluid Controls Inc  
Progressive Equipment Corp  
RGF Environmental Systems Inc  
Spectraserv  
Spectronics Corp  
Wheelabrator Environmental Systems Inc

**Ozone Detectors**

Anarad Inc  
CEA Instruments  
CHEMetrics Inc  
Columbia Science Industries Co  
Columbia Scientific  
Dasibi Environmental Corp  
Dival Safety Equipment  
EIT  
ENMET Corp  
Environmental Compliance Systems Corp  
Gilian Instrument Corp  
Metrosonics Inc  
Monitor Labs Inc  
National Draeger Inc  
**Omega Engineering Inc**  
SEE AD ON PAGE 2

**Osmonics Inc**  
SEE AD ON PAGE 31

Ozone Research & Equipment Corp An  
ProMinent Fluid Controls Inc  
Sierra Monitor Corp  
Spectraserv  
Spectrum Chemical & Safety Products  
Wheelabrator Environmental Systems Inc

**Packaged Treatment Plants**

AE Environmental Services Inc  
Alton Geoscience  
Andco Environmental Processes Inc  
AquaTec Inc  
BioTrol Inc  
Bioscience Inc  
Carbon Service & Equipment Co  
Chief Industries  
Denver Mineral Engineers Inc  
**Ejector Systems Inc**  
SEE AD ON PAGE 52

Envirex  
**Environmental Restoration Systems Inc**  
SEE AD ON PAGE 18

Fluidyne Corp  
Global Water  
H2 Oil Recovery Equipment Inc  
Hazleton Environmental  
Inn-Nova-Tech Inc  
**Met-Pro Corp Systems Div**  
SEE AD ON PAGE 43

O'Brien & Gere Technical Services Inc  
Parkson Corp  
Pollution Control Inc  
Polybac Corp  
Purestream Inc  
Solox A Division of Solar Kinetics Inc  
Suburbia Systems Corp

Tenco Hydro Inc  
Treatment Technologies  
United States Filter Corp  
**Wallace & Tierman Inc**  
SEE AD ON PAGE 29

Water Equipment Tech  
Water Inc  
Western Filter Co  
Wheelabrator Environmental  
Systems Inc

**Packing Materials**

Allflex Hazardous Material Packing Inc  
CORTEC Corp



Clean Gas Systems Inc  
Gelok Intl Corp  
Gurman Container & Supply Corp  
John Crane Inc  
Koch Engineering Co Inc  
Labelmaster  
Norton Chemical Process Products Corp  
Yellow Logistics Services Inc

**Particle Detectors**

**Auburn International Inc**  
SEE AD ON PAGE 53

Cole-Parmer Instrument Co  
Dasibi Environmental Corp  
Dival Safety Equipment  
Fisher Scientific Safety Products Div  
Hazzo Services Inc  
Hill International Inc

**Horiba Instruments Inc**  
SEE AD ON PAGE 44

Insitex Inc  
Intek Corp/Rent-Alyzer  
Midwestco Filter Resources Inc  
Sensidyne Inc  
Terra Universal  
Wheelabrator Environmental  
Systems Inc

**Particle Sizing Instruments**

CAE Express  
Clean Air Engineering  
ELE International Inc/Soiltest  
Products Div  
Glen Mills Inc  
H F Scientific Inc



Hach Co  
**Horiba Instruments Inc**  
SEE AD ON PAGE 44

Insitex Inc  
Intek Corp/Rent-Alyzer

**Passive Hydrocarbon Recovery System**

Adirondack Environmental Associates Inc  
CET Environmental Services Inc  
Clean Environment Equipment  
ENSCI Environmental Inc  
EPG Companies Inc  
Environmental Basics Co  
**Environmental Restoration Systems Inc**  
SEE AD ON PAGE 18  
National Environmental Systems Inc  
R E Wright Associates Inc (REW)

**PCB Replacement**

BEC Laboratories  
CRX Environmental Services Inc

Hill International Inc  
Rollins Environmental  
Soil & Material Engineers Inc

**PCB Testing**

ACTS Testing Labs Inc  
AE Environmental Services Inc  
AWD Technologies Inc  
Aaron Environmental Services Corp  
Accredited Laboratories Inc  
Applied Research & Development Lab  
Atlantic Testing Laboratories Limited  
B & W NESI NEL  
Braun Intertec Corp  
Burns & McDonnell  
CTL Environmental Services  
Chester Environmental  
Clean Venture/Cycle Chem  
Compu Chem Environmental Corp  
Con-Test  
Corporation for Environmental Management  
Dames & Moore  
Detail Associates Inc  
Dexsil Corp  
ENSCI Environmental Inc  
Eco Tek Laboratory Services Inc  
Ensys Environmental Products Inc  
Environmental Products & Services Inc  
Foppe Thelen Group Inc  
GTEL Environmental Laboratories  
Global Environmental Inc  
H E S Inc



Hach Co  
Hart Crowser Inc  
Hill International Inc  
Hunter Inc, Environmental Science  
Huntingdon Engineering & Environmental Inc  
International Technology Corp  
LEXICON Environmental Associates Inc  
**Lancaster Laboratories Inc**  
SEE AD ON PAGE 7

Millipore Corp  
Nytest Environmental Inc  
Pacific Analytical Inc  
Professional Analytical & Consulting Services Inc  
R E Wright Associates Inc (REW)  
Raytheon Engineers & Constructor/Raytheon Enviro Svc  
Rollins Environmental  
SRI Instruments  
SSM/Spotts Stevens & McCoy Inc  
Sentex Systems Inc  
Soil & Material Engineers Inc  
Superior Environmental Corp  
Sverdrup Environmental Inc  
Terra Bio Chem Environmental & Engineering Services Inc  
Trans-Enviro Inc  
Traverse Group, The  
Trinity Environmental Technologies  
Versar Inc  
Waste Stream Technology Inc

**Permitting**

AWD Technologies Inc  
Alton Geoscience  
Applied Science & Technology Inc  
Arthur D Little Inc  
BEM Systems Inc  
Barr Engineering Co  
Blasland Bouck & Lee Inc  
Book Environmental Service Inc  
Braun Intertec Corp  
Brown & Root Environmental  
Burns & McDonnell  
CET Environmental Services Inc  
CTL Environmental Services

Center for Hazardous Materials Research  
Chester Environmental  
Clean Air Engineering  
Consulting Environmental Engineerings Inc  
Dames & Moore  
Deeco Inc



Durr Industries Inc  
ENSCI Environmental Inc  
ERM Group, The  
Eckenfelder  
Ecotech Inc  
Enercon Services Inc  
Enviro-Sciences Inc  
Environmental Recovery Resources Inc  
Environmental Resource Center  
FBA Environmental Inc  
Foster Wheeler Environmental Corp  
Foth & Van Dyke  
Galson Corp  
GeoSyntec Consultants  
Geotrans Inc  
H H Burkitt Project Management Inc  
Haley & Aldrich Inc  
Hart Crowser Inc  
International Technology Corp  
J L A Engineering Inc  
L Robert Kimball & Associates  
Morrison, Knudsen Corp  
Ogden Environmental & Energy Services  
Parsons Engineering Science Inc  
Professional Analytical & Consulting Services Inc  
R E Wright Associates Inc (REW)  
RMT Inc  
Radian Corp  
Raytheon Engineers & Constructor/Raytheon Enviro Svc  
Recon Environmental  
Rust Environment & Infrastructure  
Rust International Inc  
SSM/Spotts Stevens & McCoy Inc  
Sewall, James W Co  
Stanley Consultants Environmental Inc  
Sverdrup Environmental Inc  
Temtest Inc/TEMPodge  
Terra Bio Chem Environmental & Engineering Services Inc  
Traverse Group, The  
Trinity Consultants Inc  
Turner EnviroLogic Inc  
Waid & Associates  
Walk, Haydel & Associates Inc

**Pest/Weed Control**



Bird-X Inc  
ECOSTAT Inc  
Spectronics Corp  
Spraying Systems Co  
**pH Instrumentation**  
AE Environmental Services Inc  
ATI Orion



**Art's Manufacturing & Supply (AMS)**  
SEE AD ON PAGE 53

Atlantic Screen & Mfg Inc  
Bailey Controls Co  
Barnart Co  
Ben Meadows  
CHEMetrics Inc  
Campbell Scientific Inc  
Capital Controls Co Inc

Cole-Parmer Instrument Co  
ELE International Inc/Soiltest  
Products Div  
Extex Instruments  
Fisher Scientific Safety Products Div  
Geoguard Inc  
George Fischer Inc  
Global Water  
H F Scientific Inc  
HNU Systems Inc



Hach Co  
Hazzo Services Inc  
**Horiba Instruments Inc**  
SEE AD ON PAGE 44  
**HydroLab Corp**  
SEE AD ON PAGE 22

Innovative Sensors Inc  
Instruments Direct Inc  
Intek Corp/Rent-Alyzer  
Isco Inc Environmental Div  
LINC Quantum Analytics  
Luft Instruments Inc  
Newport Electronics Inc  
Novalynx Corp  
**Omega Engineering Inc**  
SEE AD ON PAGE 2  
Orbeco Analytical Systems Inc  
Perstorp Analytical Inc  
ProMinent Fluid Controls Inc  
SWANIndustries Analytics  
Schneider Instrument Co  
Serflico Ltd  
Solomat  
Soltec Corp  
Taylor Technologies  
Thornton Associates Inc  
Wilkins-Anderson Co

**Pipeline Cleaning, Repair**

**Carylon Corp**  
SEE AD ON PAGE 66  
CORTEC Corp  
Environmental Services & Products Inc  
Godwin Pumps of America Inc  
Mole Master Services Corp



Nibco Inc  
O'Brien & Gere Technical Services Inc  
Pipe Liners Inc (U-Linear Pipe)  
Saufereisen

**Piping, Dual Containment**



Ameron  
Ameron Fiberglass Pipe Systems  
Asahi/America Inc  
Chemtrol Div of Nibco Inc  
Enco EMC Fiberglass Casing & Well Screens  
Fibercast Co  
Fluid Controls Inc  
Forrer Supply Co Inc  
George Fischer Inc  
MPC Containment System Ltd  
Pipe Liners Inc (U-Linear Pipe)  
Plastic Fusion Fabricators  
Plexco



Smith Fiberglass Products  
Thermoplastic Processes Inc

**Piping Equipment**

Abresist Corp  
Chemtrol Div of Nibco Inc  
Duriron Co Inc, The  
Environmental Industrial Resources  
Eslon Thermoplastics  
Fluid Controls Inc  
Forrer Supply Co Inc  
George Fischer Inc  
Godwin Pumps of America Inc  
Hancox Inc  
Jerman Waterworks Supply  
Naylor Pipe Co  
Pipe Liners Inc (U-Linear Pipe)  
Plastic Fusion Fabricators  
Ridge Tool Co  
Signmark Div/Brady USA Inc  
Swagelok Companies, The  
Total Containment Inc  
X-Pando Products Co

**Pollution Survey Equipment**

CHEMetrics Inc  
Chimtronics Corp  
Dasibi Environmental Corp  
Engelhard Corp  
Environmental Technologies Group  
Hazzo Services Inc  
Sentex Systems Inc  
Superior Signal Co Inc

**Polymer Blending/Feeding Systems**

Acrison Inc  
Andco Environmental Processes Inc  
Environmental Recovery Resources Inc  
Mastrom Co, The  
Neptune Chemical Pump Co  
Or-Tec Inc  
ProMinent Fluid Controls Inc  
Stockhausen  
Stranco Inc  
**Wallace & Tierman Inc**  
SEE AD ON PAGE 29

**Portable Computers**



Computer Allii  
SEE AD ON PAGE 120  
Hazzo Services Inc

**Pressure Boosters**

Busch Inc  
E G & G Rotron - Industrial Div  
Gardner Denver Machinery Inc  
**Omega Engineering Inc**  
SEE AD ON PAGE 2  
Transport Law Research Inc

**Pressure/Vacuum Instrumentation**

Alnor Instrument Co  
Automatic Switch Co (ASCO)  
Cole-Parmer Instrument Co  
Dickson Co, The  
Dwyer Instruments Inc  
Free Flow Inc  
Hazzo Services Inc  
MKS Instruments Inc  
Newport Electronics Inc

**Omega Engineering Inc**  
SEE AD ON PAGE 2  
Pace Transducer/CJ Enterprise  
Solomat  
Soltec Corp  
Superior Signal Co Inc  
Thornton Associates Inc

**Process Control Instrumentation**

ANVIC Controls  
APV Heat Transfer/Separation Technologies  
Acromag Inc  
Air Monitor Corp  
Antek Instruments Inc  
**Aurnburn International Inc**  
SEE AD ON PAGE 53  
Automation Products Inc  
Bailey Controls Co  
Bailey-Fischer & Porter Co  
Bristol Babcock Inc  
Campbell Scientific Inc  
Capital Controls Co Inc  
Diansachart Inc  
Dwyer Instruments Inc  
Environmental Monitor Systems Inc  
**Environmental Restoration Systems Inc**  
SEE AD ON PAGE 18  
Fluid Components Intl  
Foth & Van Dyke  
Free Flow Inc  
Gems Sensors Div  
George Fischer Inc  
Helma  
**Horiba Instruments Inc**  
SEE AD ON PAGE 44  
Instruments Direct Inc  
Invalco Inc  
Inventron Inc  
Kaye Instruments Inc  
Luft Instruments Inc  
MKS Instruments Inc  
**Milltronics Inc**  
SEE AD ON PAGE 16  
National Instruments  
Newport Electronics Inc  
**Omega Engineering Inc**  
SEE AD ON PAGE 2  
**Parker Hannifin Corp**  
SEE AD ON PAGE 144  
Perkin-Elmer Corp  
Phonetics Inc  
Powers Process Controls  
R E Wright Associates Inc (REWI)  
RMJ Machinery Inc  
Reliance Electric Co  
Rochester J L Co  
Rosemount Analytical Inc  
Sierra Monitor Corp  
Soltec Corp  
Stanley Consultants Inc  
Tel-Tru Mfg Co  
Thornton Associates Inc  
Turner Designs  
Wavetek Corp

**Process Control Instrumentation**

**Professional & Trade Associations**  
ASTM  
Air & Waste Management Association  
Professional Analytical & Consulting Services Inc  
  
**Programmable Controllers/Timers**  
Advanced Control Systems  
Boston Gear  
Campbell Scientific Inc  
Capital Controls Co Inc  
Dwyer Instruments Inc  
Free Flow Inc  
G E Co

Holophane Lighting Inc  
Inventron Inc  
Marshall Industrial Technologies  
Newport Electronics Inc  
Norris Technologies Inc  
**Omega Engineering Inc**  
SEE AD ON PAGE 2  
Phonetics Inc  
Powers Process Controls  
R E Wright Associates Inc (REWI)  
Simpson Electric Co  
TIMCO Mfg Inc  
Time Applications & Electronics

**Protective Clothing**

Ben Meadows  
Best Manufacturing Co  
Chem-Text Corp  
Chemfab Corp  
Cole-Parmer Instrument Co  
Dival Safety Equipment  
Fisher Scientific Products Div



Hach Co  
Hazco Services Inc  
ILC Dover Inc  
Kappler  
Labelmaster  
MSA  
Magid Glove & Safety Mfg Co  
Revere Products  
Spectrum Chemical & Safety Products  
Steele Inc

**Pulverizers**

ABB Raymond  
American Pulverizer Co  
Babcock & Wilcox  
Glen Mills Inc  
LaBounty Manufacturing Div of Stanley  
Hydraulic Tools  
Reliance Electric Co  
SSI Shredding Systems Inc  
Universal Process Equipment Inc

**Pump Controllers**

ANVIC Controls  
Bailey-Fischer & Porter Co  
Barnatt Co  
Cole-Parmer Instrument Co  
Dancer Communications Inc  
Diagenex Inc  
**Diversified Well Products Inc**  
SEE AD ON PAGE 30  
EPG Companies Inc  
**Ejector Systems Inc**  
SEE AD ON PAGE 52  
**Environmental Restoration Systems Inc**  
SEE AD ON PAGE 18  
Geoguard Inc



Gorman-Rupp Co, The  
Grundfos Pumps Corp  
H & H Pump & Dredge  
H2 Oil Recovery Equipment Inc  
Inventron Inc  
Luft Instruments Inc  
Marshalk Corp  
Mastrrr Co, The  
**Milltronics Inc**  
SEE AD ON PAGE 16  
Moran Manufacturing Inc  
National Environmental Systems Inc  
ORS Environmental Systems

**Omega Engineering Inc**  
SEE AD ON PAGE 2  
Pacer Pumps Div, ASM Industries Inc  
Phonetics Inc  
ProMinent Fluid Controls Inc  
R E Wright Associates Inc (REWI)  
RJ Industries Inc  
Remco Engineering  
S J Electro Systems Inc  
Sixnet  
Stokes Vacuum Inc  
Susquehanna Valley Systems Inc (SVS)  
Time Applications & Electronics  
Trilogy Controls Inc  
Warren Rupp Inc (A Unit of IDEX)

**Pumping Stations/Systems**

Air Dimensions Inc  
American Lewa Inc  
Barnes Pumps Inc (Sub of Crane Pumps & Systems Inc)  
CET Environmental Services Inc  
Cavro Scientific Instruments Inc  
Cole-Parmer Instrument Co  
**Convalt Inc**  
SEE AD ON PAGE 140  
Dancer Communications Inc  
**Diversified Well Products Inc**  
SEE AD ON PAGE 30  
Duriron Co Inc, The  
**Ejector Systems Inc**  
SEE AD ON PAGE 52  
Engineering Software  
FMI - Fluid Metering Inc  
Geoguard Inc  
Godwin Pumps of America Inc



Gorman-Rupp Co, The  
H & H Pump & Dredge  
Hudson Industries  
HYD Group  
ITT A-C Pump  
Inventron Inc  
Marshall Industrial Technologies  
Moran Manufacturing Inc  
Neptune Chemical Pump Co  
**Omega Engineering Inc**  
SEE AD ON PAGE 2  
Pacer Pumps Div, ASM Industries Inc  
Paco Pumps  
ProMinent Fluid Controls Inc  
Quality Industries Inc  
R E Wright Associates Inc (REWI)  
RJ Industries Inc  
Remco Engineering  
SRS Crisafulli Inc  
Serfilco Ltd  
Sewall, James W Co  
Smith & Loveless Inc  
Trilogy Controls Inc

**Pumps (sludge, waste-water, groundwater)**



American Lewa Inc  
**Art's Manufacturing & Supply (AMS)**  
SEE AD ON PAGE 53  
Atlantic Screen & Mfg Inc  
Baker Tanks  
Barnatt Co  
Barnes Pumps Inc (Sub of Crane Pumps & Systems Inc)  
Ben Meadows  
Blackmer Pump/DVR Res  
Bran & Luebbe Inc  
Busch Inc

Carbonair Environmental Systems  
Clean Environment Equipment  
Cole-Parmer Instrument Co  
Dancer Communications Inc  
Dean Pump Division Met Pro Corp  
**Diversified Well Products Inc**  
SEE AD ON PAGE 30  
Duriron Co Inc, The  
EPG Companies Inc  
**Ejector Systems Inc**  
SEE AD ON PAGE 52  
**Environmental Restoration Systems Inc**  
SEE AD ON PAGE 18  
Fairbanks Morse Pump Corp  
Fybroc Division Met-Pro Corp  
Gardner Denver Machinery Inc



Gator Pump Inc  
GeoPure Continental Systems & Services  
Geoguard Inc  
Godwin Pumps of America Inc



Gorman-Rupp Co, The  
Graham Mfg Co Inc  
Grundfos Pumps Corp  
Guzzler Mfg Inc  
H & H Pump & Dredge  
H2 Oil Recovery Equipment Inc  
Hazco Services Inc  
Hazleton Environmental  
Hydro Group  
IMS Inc  
ITT A-C Pump  
Industrial Filter & Pump Mfg Co  
Kornline Sanderson  
Lakeside Equipment Corp  
Landa Inc



**Liquid Waste Technology Inc**  
SEE AD ON PAGE 35  
Luft Instruments Inc  
Marshalk Corp  
Marshall Industrial Technologies  
Morlan & Morlan Inc  
National Environmental Systems Inc  
Neptune Chemical Pump Co  
Netsch Inc  
ORS Environmental Systems  
**Omega Engineering Inc**  
SEE AD ON PAGE 2  
**Osmotics Inc**  
SEE AD ON PAGE 31



Pacer Pumps  
Pacer Pumps Div, ASM Industries Inc  
Paco Pumps  
ProMinent Fluid Controls Inc  
Protoc  
QED GroundWater Specialists  
Quality Industries Inc  
R E Wright Associates Inc (REWI)  
RJ Industries Inc  
Remedial Systems Inc  
Rice Hydro Equipment Mfg  
Robbins & Myers Inc/Moyno Industrial Products Div  
SRS Crisafulli Inc  
Serfilco Ltd  
Smith & Loveless Inc  
Spectrum Medical Industries

Stokes Vacuum Inc  
Sutorbilt/Duroflow/Gardner Denver  
TIMCO Mfg Inc  
Tarty of Delaware  
Universal Process Equipment Inc  
Vaughn Co Inc  
Warren Rupp Inc A Unit of IDEX  
Waukesha Fluid Handling  
Weinman Pumps (Div of Crane Pumps & Systems Inc)  
Zimpro Environmental Inc

**Radiometer/Radiation Instrumentation**

AE Environmental Services Inc  
Ben Meadows  
Bicron, Harshaw/Bicron Radiation Measurement Products  
Climatronics Corp  
Fisher Scientific Safety Products Div  
**HI-Q Environmental Products Co**  
SEE AD ON PAGE 47  
Hazco Services Inc  
NovaLynx Corp  
Nuclear Associates  
Spectronics Corp  
Teledyne Brown Engineering - Environmental Services

**Radon, Testing & Analysis**

AE Environmental Services Inc  
CTL Environmental Services  
Compu Chem Environmental Corp  
Corporation for Environmental Management  
Covino Environmental Consulting Inc  
EPD Technology Corp  
Enercon Services Inc  
Enviros-Sciences Inc  
Environmental Products & Services Inc  
Envirosion Group Inc, The  
Hunter Inc, Environmental Science  
Jaca Corp  
Landauer Inc  
Nuclear Associates  
Occupational Health & Hygiene Corp of America  
R E Wright Associates Inc (REWI)  
Response Rentals  
Soil & Material Engineers Inc  
Teledyne Brown Engineering - Environmental Services  
Versar Inc

**Recorder Accessories**

A I W Inc  
Bailey-Fischer & Porter Co  
Campbell Scientific Inc  
Climatronics Corp  
Cole-Parmer Instrument Co  
Dwyer Instruments Inc  
Earth & Atmospheric Sciences Inc



Hach Co  
Hazco Services Inc  
Kipp & Zonen  
Monarch Instrument  
NovaLynx Corp  
**Omega Engineering Inc**  
SEE AD ON PAGE 2  
Powers Process Controls  
R E Wright Associates Inc (REWI)

**Recorders**

Bacharach Inc  
Bailey Controls Co  
Bailey-Fischer & Porter Co  
Bristol Babcock Inc

Campbell Scientific Inc  
 Capital Controls Co Inc  
 Climatronics Corp  
 Coastal Environmental Systems  
 Cole-Parmer Instrument Co  
 Dianachart Inc  
 Dickson Co, The  
 Dieterich Standard, a Dover Industries Co  
**SEE AD ON PAGE 64**  
 Dwyer Instruments Inc  
 Earth & Atmospheric Sciences Inc  
 G O Environment Inc



Hach Co  
 Hazco Services Inc  
 Kipp & Zonen  
 Monarch Instrument  
 Newport Electronics Inc  
 NovaLynx Corp  
**Omega Engineering Inc**  
**SEE AD ON PAGE 2**  
 Powers Process Controls  
 R E Wright Associates Inc (REWI)  
 Simpson Electric Co  
 Soltec Corp  
 Telog Instruments Inc

**Recycling Equipment/Services**

ABB Raymond  
 AFL Industries Inc  
 Advanced Environmental Recycling Corp  
 American Pulverizer Co  
 American Rolloff  
 Babcock & Wilcox  
 Baler Equipment Co  
 Bes-Pac Inc  
 Carbon Service & Equipment Co  
 Chem-Tainer Industries  
 Clean Soil Inc  
 College Research Corp (CORECO)  
 Diagraph Corp  
 Discflo Corp  
 Eager Beaver Recycling Equipment  
 Enviro Filtration  
 FBA Environmental Inc  
 Franco Environmental Technologies  
 General Kinematics Corp  
 Graef Anhalt Schloemer  
 Hazen & Sawyer  
 Heritage Environmental Services Inc  
 Hyde Products Inc  
 J V Mfg Inc/Cram-A-Lot  
 LaBounty Manufacturing Div of Stanley  
 Hydraulic Tools  
 MAC Corp/Saturn Shredders  
 Marathon Equipment Co  
 Marshall Industrial Technologies  
 Maxi Products Co Inc  
 Morlan & Morlan Inc  
 National Recycling Equipment Co  
 Pigas Waste Equipment Inc  
 Purus Inc  
 RMT Inc  
 Remco Engineering  
 Rust Environment & Infrastructure  
 Rust International Inc



Safety Klean Corp  
 Serio-Us Lock  
 Techtreat Corp  
 Twenty one/21 EMI/Elicam  
 Vac-U-Max  
 Wellington Environmental Consulting & Construction Inc

**Reference Material**

AccuStandard Inc  
 Environmental Resource Center  
 Genium Publishing Corp  
 Keoc R & D Inc  
 Marathon Equipment Co  
 Ultra Scientific Inc



**Williams Knowledge Systems Inc**  
**SEE AD ON PAGE 9**

**Reflectometers**

EG & G Marine Instruments  
 NAO Inc

**Refractometers**

Automation Products Inc  
 Cole-Parmer Instrument Co  
 Epic Inc  
 Extech Instruments



Hach Co  
**Omega Engineering Inc**  
**SEE AD ON PAGE 2**  
 Wilkens-Anderson Co

**Refractory Materials**

ERS Services  
 Ferro Corp, Specialty Ceramics Div/Cesco Plant  
 Ferro Corp, Specialty Ceramics Div/Filtros Plant  
 Ferro Corp, Specialty Ceramics Div/Louthan Plant  
 Filtros Plant, Ferro Corp  
 Saureisen  
 Wheelabrator Environmental Systems Inc

**Regulators**

Capital Controls Co Inc  
 MKS Instruments Inc  
**Osmotics Inc**  
**SEE AD ON PAGE 31**  
**Parker Hannifin Corp**  
**SEE AD ON PAGE 144**  
 Spraying Systems Co

**Remediation**

ATI  
 AWD Technologies Inc  
 Alton Geoscience  
 Angui Environmental Systems Inc  
 Artesian Environmental  
 Arthur D Little Inc  
 Atlantic Testing Laboratories Limited  
 BEM Systems Inc  
 Barnebey & Sutcliffe Corp  
 Bioscience Inc  
 Bock Environmental Service Inc  
 Brown & Root Environmental  
 Burns & McDonnell  
 CET Environmental Services Inc



Cedarapids Inc A Raytheon Co  
 ChemCycle Corp  
 Chemical Information System  
 Clean Environment Equipment  
 Clean Soil Inc  
 Clean Venture/Cycle Chem

Dames & Moore  
 Dancer Communications Inc  
 Deeco Inc  
 Ditch Witch  
 E S E Bioscience  
 EA Engineering, Science & Technology Inc  
 ENSCI Environmental Inc  
 EPG Companies Inc  
 ERM Group, The  
 ERM-South Inc  
**Ejector Systems Inc**  
**SEE AD ON PAGE 52**

Envirex  
 Enviro-Sciences Inc  
 Envirogen Inc  
**Environmental Restoration Systems Inc**  
**SEE AD ON PAGE 18**

Envirovision Group Inc, The  
 FERtech Environmental Inc  
 Ferrick Construction Co Inc  
 Finch Manufacturing Co Inc  
 Foppe Thelen Group Inc  
 Foster Wheeler Environmental Corp  
**Geo-Con Inc**  
**SEE AD ON PAGE 54**

General Carbon Corp  
 Geo-Technology Associates Inc  
 GeoSynTec Consultants  
 Geotrans Inc  
 Graef Anhalt Schloemer  
 Great Lakes Environmental Inc  
 Green Earth Technologies Corp  
 Groundwater Service & Supply Inc  
 Groundwater Technology Inc  
 H2 Oil Recovery Equipment Inc  
 Hart Crowser Inc  
 HazWaste Technologies Corp  
 Hazleton Environmental  
 Heritage Environmental Services Inc  
 Heyl & Patterson Inc  
 High Voltage Environmental  
 Hill Manufacturing Co Inc  
 Horizontal Technologies Inc  
 Hydro Group  
 Hydro-Terra Inc  
 International Technology Corp  
 Johnson Matthey Env  
 Keating Environmental Management Inc  
 Kornline Sanderson  
 L Robert Kimball & Associates  
 LEXICON Environmental Associates Inc  
 Lamson Corp  
 Lincoln Automotive  
 Lindmark Engineering Inc  
 Medina Agriculture Products Co Inc  
 ModuTank Inc  
 Monarch Separators Inc  
 National Environmental Systems Inc  
**National Technical Systems Inc**  
**SEE AD ON PAGE 17**  
 O'Brien & Gere Technical Services Inc  
 Ogden Environmental & Energy Services  
 Oxford Environmental Inc  
 PDG Environmental Inc  
 Parsons Engineering Science Inc  
 Peoria Disposal Co  
 Portec Construction Equip Div  
 Quality Industries Inc  
 R E Wright Associates Inc (REWI)  
 R Excavating Inc "Environmental Contractor"  
 Raytheon Engineers & Constructors/Raytheon Enviro Svc  
 Rust International Inc  
 SSM/Spotts Stevens & McCoy Inc  
 Seneca Environmental Services Inc  
 Serengeti Environmental

Soil Safe  
 Stanley Consultants Environmental Inc  
 Superior Environmental Corp  
 Sverdrup Environmental Inc  
 TRAK Environmental Group Inc  
 Terra Bio Chem Environmental & Engineering Services Inc  
 Traverse Group, The  
**Unipure Environmental**  
**SEE AD ON PAGE 10**  
 United States Filter Corp  
 Walk, Haydel & Associates Inc  
 Waste Stream Technology Inc

**Remediation, Insitu**

ABB Environmental Services Inc  
 ABB Raymond  
 AE Environmental Services Inc  
 ATI  
 Aaron Environmental Services Corp  
 Adirondack Environmental Associates Inc  
 Alton Geoscience  
 Andco Environmental Processes Inc  
 Bioscience Inc  
 Blasland Bouck & Lee Inc  
 Braun Intertec Corp  
 Brown & Root Environmental  
 CET Environmental Services Inc  
 Clean Soil Inc  
 Consulting Environmental Engineers Inc  
 Conwed Environmental  
 Dames & Moore  
 Deeco Inc  
**Diversified Well Products Inc**  
**SEE AD ON PAGE 30**

E S E Bioscience  
 EA Engineering, Science & Technology Inc  
 ENSCI Environmental Inc  
 ERM Group, The  
 Eckerleider  
 Ecotech Inc  
 Envirogen Inc  
 Environmental Fuel Systems Inc  
 Envirovision Group Inc, The  
 FERtech Environmental Inc  
 Ferrick Construction Co Inc  
 Foppe Thelen Group Inc  
 Foster Wheeler Environmental Corp  
 GeoSynTec Consultants  
**Geo-Con Inc**  
**SEE AD ON PAGE 54**

Global Environmental Inc  
 Green Earth Technologies Corp  
 Groundwater Service & Supply Inc  
 Groundwater Technology Inc  
 H2 Oil Recovery Equipment Inc  
 Hart Crowser Inc  
 Hayward Baker Environmental  
 HazWaste Technologies Corp  
 Heritage Environmental Services Inc  
 Horizontal Technologies Inc  
 International Technology Corp  
 L Robert Kimball & Associates  
 LEXICON Environmental Associates Inc  
 Lindmark Engineering Inc  
 Medina Agriculture Products Co Inc  
 National Environmental Systems Inc  
**National Technical Systems Inc**  
**SEE AD ON PAGE 17**  
 O'Brien & Gere Technical Services Inc  
 Oxford Environmental Inc  
 Parsons Engineering Science Inc  
 Peoria Disposal Co  
 QED GroundWater Specialists  
 R E Wright Associates Inc (REWI)  
 RMT Inc  
 Radian Corp  
 Raytheon Engineers & Constructors/Raytheon Enviro Svc  
 Recon Environmental  
 Reef Industries Inc  
 Rust International Inc  
 Serengeti Environmental



Sevenson Environmental Services Inc  
 Smith & Loveless Inc  
 Soil & Material Engineers Inc



Sevenson Environmental Services Inc  
 Soil & Material Engineers Inc  
 Superior Environmental Corp  
 Sverdrup Environmental Inc  
 TRAK Environmental Group Inc  
 Terra Bio Chem Environmental & Engineering Services Inc  
 Traverse Group, The  
 Walk, Haydel & Associates Inc  
 Waste Stream Technology Inc

**Remediation Services**

ABB Environmental Services Inc  
 AE Environmental Services Inc  
 AIG Consultants Inc  
 ARD Environmental Inc  
 ATEC Associates Inc  
 ATI  
 AWD Technologies Inc  
 Aaron Environmental Services Corp  
 Adirondack Environmental Associates Inc  
 Alliance Environmental Inc  
 Alton Geoscience  
 Applied Science & Technology Inc  
 Artesian Environmental  
 Atlantic Testing Laboratories Limited  
 BEM Systems Inc  
 Barnebey & Sutcliffe Corp  
 Bioscience Inc  
 Blasland Bouck & Lee Inc  
 Book Environmental Service Inc  
 Braun Intertec Corp  
 Brown & Root Environmental  
 Burns & McDonnell  
 CET Environmental Services Inc  
 CARX Environmental Services Inc  
 Carbon Service & Equipment Co  
 Chentrail Environmental Inc  
 Chester Environmental  
 Clean Soil Inc  
 Clean Venture/Cycle Chem  
 Compu Chem Environmental Corp  
 Consulting Environmental Engineers Inc  
 Dames & Moore  
 Deeco Inc  
 E S E Bioscience  
 EA Engineering, Science & Technology Inc  
 EET Inc  
 EMPE Inc  
 ENSCI Environmental Inc  
 ERM Group, The  
 ERM-South Inc  
 Ecotech Inc  
 Enercon Services Inc  
 Enviro-Sciences Inc  
 Envirogen Inc  
 Environmental Fuel Systems Inc  
 Environmental Technologies Group  
 Envirovision Group Inc, The  
 FBA Environmental Inc  
 FERtech Environmental Inc  
 Ferrick Construction Co Inc  
 Foppe Thelen Group Inc  
 Foster Wheeler Environmental Corp  
 General Carbon Corp  
 GeoSynTec Consultants  
 Geotrans Inc  
 Global Environmental Inc  
 Green Earth Technologies Corp  
 Groundwater Service & Supply Inc  
 Groundwater Technology Inc  
 H2 Oil Recovery Equipment Inc  
 Haley & Aldrich Inc  
 Hart Crowser Inc  
 Hayward Baker Environmental  
 HazWaste Technologies Corp  
 Heritage Environmental Services Inc  
 Hill International Inc  
 Horizontal Technologies Inc  
 Hydro Group

International Engineers Inc  
International Technology Corp  
Keating Environmental Management Inc  
Kennedy/Jenks Consultants  
L Robert Kimball & Associates  
LEXICON Environmental Associates Inc  
Lindmark Engineering Inc  
Medina Agriculture Products Co Inc



**MORRISON  
KNUDSEN  
CORPORATION**  
208-386-5502

Morrison, Knudsen Corp  
**National Technical Systems Inc**  
SEE AD ON PAGE 17

Northeast Environmental Services  
O'Brien & Gere Technical Services Inc  
Ogden Environmental & Energy Services  
Oxford Environmental Inc  
Parsons Engineering Science Inc  
Peoria Disposal Co  
Professional Service Industries Inc  
R E Wright Associates Inc (REWI)  
R Excavating Inc "Environmental Contractor"  
RMT Inc  
Radian Corp  
Raytheon Engineers & Constructor/Raytheon Enviro Svc  
Recon Environmental  
Resource Consultants Inc  
Rollins Environmental  
Rust Environment & Infrastructure  
Rust International Inc  
SSM/Spotts Stevens & McCoy Inc  
Seneca Environmental Services Inc  
Serengeti Environmental



**Sevenson  
Environmental  
Services, Inc.**  
716-284-0431

Sevenson Environmental Services Inc  
Soil & Material Engineers Inc  
Soil Safe  
Spectraserv  
Stanley Consultants Inc  
Stearns & Wheeler  
Superior Environmental Corp  
Sverdrup Environmental Inc  
TRAK Environmental Group Inc  
Terra Bio Chem Environmental & Engineering Services Inc  
Traverse Group, The  
**Unipure Environmental**  
SEE AD ON PAGE 10  
Vamco Engineering Group  
Versar Inc  
Waste Stream Technology Inc

**Rental Services**

ASC Professionals  
Alton Geoscience  
American Scientific Instrumentation  
Anguil Environmental Systems Inc  
CAE Instrument Rental  
CRX Environmental Services Inc  
Climatronics Corp  
Coastal Leasing Inc  
**Environmental Restoration Systems Inc**

SEE AD ON PAGE 18

Forrer Supply Co Inc  
Frontier Technology Inc  
Godwin Pumps of America Inc  
H2 Oil Recovery Equipment Inc  
Hazzo Services Inc  
Hazleton Environmental  
Intek Corp/Rent-Alyzer  
Isco Inc Environmental Div  
LINC Quantum Analytics  
**Milco Safety Rental**

SEE AD ON PAGE 64

Osmonics Inc  
SEE AD ON PAGE 31

Pace Transducer/CJ Enterprise  
Pentek Inc  
R E Wright Associates Inc (REWI)  
Seneca Environmental Services Inc

**Research Services**

Agency Information Consultants Inc (AIC)

**Respirometers**

Anatel Corp  
Arthur Technology Inc  
Bioscience Inc  
Coastal Leasing Inc

**Reverse Osmosis Equipment**

APV Heat Transfer/Separation Technologies  
Aqua-Chem Inc



**DESAL**  
DESALINATION SYSTEMS, INC.  
619-746-4995

**Desalination Systems Inc**  
SEE AD ON PAGE 163

Dow Chemical Co, The  
Hyde Products Inc  
Ionics Inc  
**Osmonics Inc**  
SEE AD ON PAGE 31  
RGF Environmental Systems Inc  
Remco Engineering  
Smith & Loveless Inc  
Soil & Material Engineers Inc  
United States Filter Corp  
Universal Process Equipment Inc  
Water Equipment Tech  
Western Filter Co  
Wheelabrator Engineered Systems Inc - Memtek Products  
Zimpro Environmental Inc

**Risk Analysis**

ABB Environmental Services Inc  
ATEC Associates Inc  
AWD Technologies Inc  
Air Science Consultants  
Arthur D Little Inc  
Atlantic Testing Laboratories Limited  
BEM Systems Inc  
Barr Engineering Co  
Blasiand Bouck & Lee Inc  
Braun Intertec Corp  
Burns & McDonnell  
CET Environmental Services Inc  
DNV Technica Inc  
Dames & Moore  
Deeco Inc  
EA Engineering, Science & Technology Inc  
Eckelfelder  
Enercon Services Inc  
Environmental Standards Inc  
FBA Environmental Inc  
Foster Wheeler Environmental Corp  
Foth & Van Dyke  
G A Huber Co  
Galsion Corp  
Gannett Fleming Inc  
Groundwater Technology Inc  
Haley & Aldrich Inc  
Hart Crowsier Inc  
Hazmat America Inc  
Hill International Inc  
International Technology Corp  
L Robert Kimball & Associates  
LEXICON Environmental Associates Inc  
Mabbett & Associates Inc

**National Technical Systems Inc**

SEE AD ON PAGE 17

Parsons Engineering Science Inc  
Professional Analytical & Consulting

Services Inc  
R E Wright Associates Inc (REWI)  
Raytheon Engineers & Constructor/Raytheon Enviro Svc  
Rollins Environmental  
Superior Environmental Corp  
TRAK Environmental Group Inc  
Terra Bio Chem Environmental & Engineering Services Inc  
Traverse Group, The  
Trinity Consultants Inc  
Versar Inc  
Walk, Haydel & Associates Inc  
Williams Knowledge Systems Inc

**Rupture Disks**

Fike Corp

**Safety Equipment & Products**

AIM Safety USA Inc  
American Gas Products Inc  
Ben Meadows  
Bergen Barrel & Drum  
Biomarine Inc  
CEA Instruments  
CHEM-Tel Inc  
Cabot Safety Corp  
Capital Controls Co Inc  
Chem-Tex Corp  
Cole-Parmer Instrument Co  
Direct Safety Co  
Dival Safety Equipment  
ENMET Corp  
ENPAC Corp  
EPD Technology Corp  
Environmental Products & Services Inc  
Fike Corp  
Fisher Scientific Safety Products Div  
Genium Publishing Corp  
Georgia Steel & Chemical  
**Goodway USA**

SEE AD ON PAGE 41

Gurman Container & Supply Corp  
Hazzo Services Inc  
Heart Information Systems Inc  
Hild Floor Machine  
Integra Plastics Inc  
International Safety Instruments  
J J Keller & Associates Inc  
Justrite Mfg Co/Div of Federal Signal Corp  
Kappler  
Lab Safety Supply  
Labelmaster  
MSA  
Magid Glove & Safety Mfg Co  
Metrosonics Inc  
Nalge Co  
National Draeger Inc  
National Marker Co  
Neoterik Health Technologies Inc

**New Pig Corp**

SEE AD ON PAGE 138

Nilfisk of America Inc  
North Safety Products  
North Safety Products, Safety Equipment Div  
Nuclear Associates  
Pentek Inc  
Pro-Tech Respirators Inc  
Remco Products Corp  
Safe Environmental Storage Corp  
**Safety Storage Inc**

SEE AD ON PAGE 70

Sensidyne Inc  
Sierra Monitor Corp  
Signmark Div/Bradly USA Inc  
Speakman Co  
Spectronics Corp  
Spectrum Chemical & Safety Products  
Steele Inc  
Summit Training Source  
Tenax Corp  
Ultech International  
Uvex Safety LLC

Valley Videos  
Wheaton Science Products



**Williams Knowledge Systems Inc**  
SEE AD ON PAGE 2744

**Williams Knowledge Systems Inc**

SEE AD ON PAGE 9

Wonder Makers Inc  
Ziamatic Corp

**Sample Containers**

Afflex Hazardous Material Packing Inc  
Associated Design & Mfg  
B A G Corp  
Ben Meadows  
Compu Chem Environmental Corp



**EAGLE PICHER**  
1-800-331-7425

Eagle-Picher/Env Science & Technology  
Fisher Scientific Safety Products Div  
Gurman Container & Supply Corp  
Hazzo Services Inc  
Labelmaster  
Nalge Co  
Plastic Film Enterprises  
Polyfoam Packers Corp  
Scientific Specialties Services Inc  
Sunshine Technology Corp  
Wheaton Science Products  
Wonder Makers Inc

**Sampling Systems**

Air Metrics  
American Sigma Inc  
Anarad Inc



**AA Applied Automation  
Hartman & Braun**  
918-662-7343

**Applied Automation/Hartman & Braun**  
SEE AD ON PAGE 164



**1-800-635-7330**

**Art's Manufacturing & Supply (MS)**

SEE AD ON PAGE 53

Associated Design & Mfg



**BVS 610-273-2841**

BVS Inc

Bacharach Inc  
Barnart Co  
Bralstorf & Company  
CET Environmental Services Inc  
Clean Air Engineering  
Clean Environment Equipment  
**Diversified Well Products Inc**  
SEE AD ON PAGE 30

Enco EMC Fiberglass Casing & Well Screens  
Entech Instruments Inc  
Environmental Fuel Systems Inc  
Environmental Monitor Systems Inc  
FMI - Fluid Metering Inc  
G O Environment Inc  
Geoguard Inc  
Glen Mills Inc  
Global Environmental Inc  
Grasby Specac Inc  
**HI-Q Environmental Products Co**  
SEE AD ON PAGE 47  
Hazzo Services Inc  
Isco Inc Environmental Div  
LINC Quantum Analytics

Lab Safety Supply



**1-800-645-7339**

**MMC Intl Corp**

SEE AD ON PAGE 23

Marshall Corp  
Neptune Chemical Pump Co  
Perkin-Elmer Corp  
Plastic Film Enterprises  
Professional Analytical & Consulting Services Inc  
Protec  
Rochester J L Co  
Sensidyne Inc  
Ben Meadows Co Inc  
TIMCO Mfg Inc  
Teledyne Brown Engineering/Analytical Instruments  
Wheaton Science Products  
Wonder Makers Inc

**Screens**

American Pulverizer Co

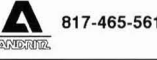

**817-465-5611**

Andritz Ruther Inc  
Baler Equipment Co



**Gedarapids**  
A Raytheon Company  
319-363-3511

Gedarapids Inc A Raytheon Co  
**Diversified Well Products Inc**  
SEE AD ON PAGE 30

Enco EMC Fiberglass Casing & Well Screens  
Envirex  
Enviro Care  
Frontier Technology Inc  
General Kinematics Corp  
Glen Mills Inc  
IPEC Industries  
JWC International  
Multitek Inc  
Parkson Corp  
Portec Construction Equip Div  
Schreiber Corp Inc  
Smith & Loveless Inc  
Spectrum Medical Industries  
Universal Process Equipment Inc

**Scrubbers**

Advance Machine Co



**708-394-9553**

Advanced Air Tech Inc  
Advanced Industrial Technology Corp  
Air Plastics Inc  
Airotech  
Ambient Engineering Inc  
American Environmental International Inc  
Anderson 2000 Inc  
Atlas Minerals & Chemicals Inc  
Babcock & Wilcox  
Beltran Associates Inc  
Burns & McDonnell  
CMI-Schnelbe Co  
CSM Environmental Systems Inc  
CVM Corp



**516-467-1600**

Clean Gas Systems Inc



Tell me  
we're in  
**compliance.**

Please.



# Comprehensive regulatory substance information from CAS. For your peace of mind.

If you've ever felt your heart quicken at the thought of not being in compliance, our substance information services can offer some peace of mind.

- CASurveyor<sup>SM</sup>: Regulatory Compliance — on CD-ROM, includes substances from national inventories... in addition to our other environmental titles on CD-ROM.
- CHEMLIST<sup>®</sup> — an authoritative online database for substances that are subject to regulation.
- CAS REGISTRY<sup>SM</sup> — an online database of 13 million substances, and 18 million synonyms and inventory flags.
- Searching on demand by CAS experts — just ask, and we'll provide the information for you.
- CA Selects — a collection of economical printed bulletins including many environmental topics.

It's your choice. Call our search experts to do the searching for you. Search CHEMLIST or CAS REGISTRY on our STN<sup>®</sup> network from your own computer. Or order our Regulatory Compliance CD-ROM.

**SAVE \$50**  
ON THE FIRST SEARCH  
CAS CONDUCTS FOR YOU!

In any case, you'll have complete access to the TSCA Inventory, Canadian lists, and European inventories, ...with more to come this year. You'll also find CAS Registry Numbers<sup>®</sup> for EPA reporting.

Call **800-933-4350** or **614-447-3731**. FAX **614-447-3751**. Or Internet URL <http://info.cas.org/welcome.html>.

We don't just load the inventories, CAS chemists review their chemical names and CAS Registry Numbers.

In this world, there is some information you absolutely have to know.



Circle 81 on card.

A Division Of The American Chemical Society<sup>®</sup>

College Research Corp (CORECO)  
 Croll Reynolds Co Inc  
 Discflo Corp  
 Duall Div Met-Pro Corp  
 Ducon Environmental Systems Inc  
 EPG Companies Inc  
 ERS Services  
 Engelhard Corp  
 Environmental Techniques  
 Hazco Services Inc  
 Hild Floor Machine  
 Koch Engineering Co Inc  
 Minuteman Intl Inc  
 Misonix Inc  
 Monroe Environmental Corp



Monsanto Enviro-Chem  
 Remedial Systems Inc  
 Schutte & Koerting Division Ketema Inc  
 Stanley Consultants Inc  
 Tri-Mer Corp  
 Turner EnviroLogic Inc  
 United McGill Corp  
 Universal Process Equipment Inc  
 Wheelabrator Air Pollution Control



Whessoe Varec  
 Zink, John Co Div of Koch  
 Engineering Co Inc  
 Zum Industries, Air Systems Div

## Sealants

Amfuel  
 Atlantic Screen & Mfg Inc  
 Discflo Corp  
 EPD Technology Corp  
 G E Co  
 Measurement & Flow Control



Morton International Inc  
 Polyspec Corp  
 Rhone-Poulenc Inc  
 Specialty Chemicals Div  
 Swagelok Companies, The  
 W L Gore & Associates Inc  
 X-Pando Products Co

## Secondary Containment

Air Plastics Inc  
 American Safety Products Inc  
 Amfuel  
 Aro-Power Utilized Fueler Inc  
 Assman Corp of America  
 Atlas Minerals & Chemicals Inc  
 Bailey-Fischer & Porter Co  
 Baker Tanks  
 Benko Products Inc  
 Bergen Barrel & Drum  
 Bixby International Corp



Chem-Tainer Industries  
 ENPAC Corp  
 Enercon Services Inc  
 Environmental Container Corp  
 Environmental Products & Services Inc



Fabrico Environmental Liners Inc  
 Fluid Controls Inc  
 George Fischer Inc  
 Gundie Lining Systems Inc  
 Gurman Container & Supply Corp  
 Haz Mat Containment Corporation  
 Haz-Stor Co  
 Hazco Services Inc  
 ILC Dover Inc  
 Integra Plastics Inc  
 LEXICON Environmental Associates Inc  
 Lab Safety Supply  
 Labelmaster  
 MPC Containment System Ltd  
 Marshall Industrial Technologies  
 Maxi Container Inc  
 ModuTank Inc  
**New Pig Corp**

SEE AD ON PAGE 138

## Omega Engineering Inc

SEE AD ON PAGE 2  
 Parkline Inc  
 Plastic Fusion Fabricators  
 Plexco  
 Polyspec Corp  
 Process Solutions  
 Reef Industries Inc  
 Safe Environmental Storage Corp  
**Safety Storage Inc**  
 SEE AD ON PAGE 70  
 Saureisen  
 Skolnik Industries Inc



Smith Fiberglass Products  
 Spectrum Chemical & Safety Products  
 Total Containment Inc  
 Ultratec International  
 Watersaver Co Inc  
 Youngstown Barrel & Drum Co

## Sedimentation Equipment

Automation Products Inc  
 EIMCO Process Equipment Co  
 Envirex  
 Great Lakes Environmental Inc  
 Hazco Services Inc  
 Monarch Separators Inc  
 SRS Crisafulli Inc  
 Wheelabrator Environmental  
 Systems Inc

## Sensors

ADS Environmental Services Inc  
 Anderaas Instruments Inc  
 Agar Corp  
 Atlantic Screen & Mfg Inc  
**Auburn International Inc**

SEE AD ON PAGE 53

Bacharach Inc  
 Bailey Controls Co  
 Barnart Co  
 Boston Gear  
 CEA Instruments  
 Campbell Scientific Inc  
 Climatronics Corp  
 Control Instruments Corp  
 Dwyer Instruments Inc  
 EBW Inc  
 ELE International Inc/Soiltest  
 Products Div  
 EPG Companies Inc  
 Environmental Monitor Systems Inc  
 Environmental Technologies Group  
 Everest Interscience Inc  
 Fluid Components Intl  
 Fluorware

G E Co  
 G O Environment Inc  
 Gems Sensors Div  
 George Fischer Inc  
 Global Water  
 H F Scientific Inc  
 Hazco Services Inc  
 Helma  
 Hersey & Measurement  
**HydroLab Corp**

SEE AD ON PAGE 22

International Sensor Technology  
 MKS Instruments Inc  
 McNeill International

**Met-One Instruments Inc**

SEE AD ON PAGE 26

Metriplate Inc  
 Midwest Filter Resources Inc

**Miltronics Inc**

SEE AD ON PAGE 16

National Draeger Inc  
 Newport Electronics Inc  
 NovaLynx Corp  
 Nuclear Associates  
 Pace Transducer/CJ Enterprise  
 Panametrics PCI Div  
 Qualimetrics Inc  
 Sensidyne Inc  
 Sierra Monitor Corp  
 Soltec Corp  
 Teledyne Brown Engineering/Analytical  
 Instruments  
 Thornton Associates Inc  
 Time Mark Corp  
 Transducer Research  
 Universal Sensors & Devices Inc  
 Vitel Inc

## Separation Systems

APV Heat Transfer/Separation  
 Technologies  
 Adironack Environmental Associates Inc  
 AirSep Corp  
 Baker Tanks  
 Baler Equipment Co  
 Beko Condensate Systems Corp  
 Bird Machine Co Inc  
 Colloid Environmental Technologies Co  
 Discflo Corp  
 Ducon Environmental Systems Inc  
 EIMCO Process Equipment Co  
 Envirex  
 Environmental Products & Services Inc  
 Frontier Technology Inc  
 Great Lakes Environmental Inc  
 Griswold Controls  
 Heritage Environmental Services Inc  
 Hudson Industries  
 Hyde Products Inc  
 Industrial Filter & Pump Mfg Co



JMI  
 Monarch Separators Inc  
 Nautus Inc  
 O'Brien & Gere Technical Services Inc

**Osmotics Inc**

SEE AD ON PAGE 31

Perkin-Elmer Corp  
 Remco Engineering  
 Sharples, Business Unit of Alfa Laval  
 Separation  
 Smith & Loveless Inc  
 Spectrum Medical Industries  
 Tedder & Widhelm Consultants Inc  
 United States Filter Corp  
 Wheelabrator Environmental  
 Systems Inc  
 Zimpro Environmental Inc

## Separators

Adironack Environmental Associates Inc

Baker Tanks  
 Baler Equipment Co  
 Beko Condensate Systems Corp  
 Bird Machine Co Inc  
 Breslove Separator Co Inc



CGS  
 516-467-1600

Clean Gas Systems Inc  
 Discflo Corp  
 Ducon Environmental Systems Inc  
 EIMCO Process Equipment Co  
 EPG Companies Inc  
**Ejector Systems Inc**

SEE AD ON PAGE 52

Envirex  
 Environmental Products & Services Inc  
 Environmental Recovery Resources Inc  
 Frontier Technology Inc  
 Gelok Intl Corp  
 General Kinematics Corp  
 Great Lakes Environmental Inc  
 Griswold Controls  
 Highland Tank  
 Hitachi Maxco Ltd  
 Hudson Industries  
 Hyde Products Inc  
 Industrial Filter & Pump Mfg Co  
 Krebs Engineers  
 McTighe Industries Inc  
 Monarch Separators Inc  
 Monroe Environmental Corp  
 Nautus Inc  
 Oil Skimmers Inc  
**Parker Hannifin Corp**

SEE AD ON PAGE 144

Remco Engineering  
 Remedial Systems Inc  
 Sharples, Business Unit of Alfa Laval  
 Separation  
 Smith & Loveless Inc  
 Sunshine Technology Corp  
 Tedder & Widhelm Consultants Inc  
 Universal Process Equipment Inc  
 Zimpro Environmental Inc

## Septic Tanks



Amfuel  
 Bacteria Concepts Inc



Chem-Tainer Industries  
 Gurman Container & Supply Corp  
 Infiltrator Systems Inc

## Sequencing Batch Reactors

AquaTec Inc  
 BioTrol Inc  
 Denver Mineral Engineers Inc  
 Fluidyne Corp  
 Framco Environmental Technologies  
 Purestream Inc  
 United States Filter Corp

## Settling Chambers

Ducon Environmental Systems Inc  
 Western Filter Co

## Sewage/Sludge Disposal Equipment/Services

ABB Raymond



Ag-Chem Equipment Co  
 Baler Equipment Co  
 Capital Controls Co Inc  
 Carbtrol Corp  
 Chester Environmental  
 College Research Corp (CORECO)  
 Consulting Environmental  
 Engineers Inc  
 Convento Mfg Co Inc  
 Discflo Corp  
 Ducon Environmental Systems Inc  
 Envirex  
 FBA Environmental Inc  
 Frontier Technology Inc  
 Galbreath Inc  
 Godwin Pumps of America Inc  
 Hankin Environmental Systems Inc  
 Hart Crowsier Inc  
 Hazen & Sawyer  
 Hitachi Maxco Ltd  
 IMS Inc  
 Komline Sanderson

**Liquid Waste Technology Inc**

SEE AD ON PAGE 35

Marshall Industrial Technologies  
 ModuTank Inc  
 Niroline  
 O'Brien & Gere Technical Services Inc  
 Ogden Environmental & Energy Services  
 R E Wright Associates Inc (REW)  
 RMT Inc  
 Raytheon Engineers &  
 Constructor/Raytheon Enviro Svc  
 Research Products/Blankenship  
 Rust Environment & Infrastructure  
 Rust International Inc  
 SRS Crisafulli Inc  
 Serpentin Conveyor Corp  
 Spectraserv  
 Sverdrup Environmental Inc  
 Universal Process Equipment Inc  
 Zimpro Environmental Inc

## Sewage Transport Systems

ARD Environmental Inc  
 Ameron Fiberglass Pipe Systems  
 Convento Mfg Co Inc  
 Graef Anhalt Schloemer  
 Kinane Engineering  
 Sewall, James W Co  
 Spectraserv

## Sewerage Systems, Vacuum

Busch Inc

## Sewer Inspection TV System

Chester Environmental  
 Gannett Fleming Inc  
 R E Wright Associates Inc (REW)  
 Sewall, James W Co  
 Sverdrup Environmental Inc

## Shelters

Climatronics Corp  
 Cover-It Instant Garage All Weathers  
 Shelters  
**Fabric Building Systems Inc**  
 SEE AD ON PAGE 32  
**Met-One Instruments Inc**  
 SEE AD ON PAGE 26  
 NovaLynx Corp  
 PACE Environmental Products  
 Parkline Inc

**Shredders**

Ameri-Shred Corp  
 American Pulverizer Co  
 Baler Equipment Co  
 Blower Application Co  
 Entoleter Inc  
 Glen Mills Inc  
 JWC Environmental  
 MAC Corp/Saturn Shredders  
 Morlan & Morlan Inc  
 Multitek Inc  
 O & E Machine Corp  
 Portec Construction Equip Div  
 SSI Shredding Systems Inc  
**Shred-Tech**  
**SEE AD ON PAGE 38**  
 Univeral Engineering  
 Vacuum Engineering  
 Vector Technologies Ltd

**Signal Conditioners**

Acromag Inc  
 Bailey-Fischer & Porter Co  
 Climatronics Corp  
 Monarch Instrument  
 National Instruments  
 Newport Electronics Inc  
 NovaLynx Corp  
**Omega Engineering Inc**  
**SEE AD ON PAGE 2**  
 Soil & Material Engineers Inc  
 Soltec Corp  
 Wavetek Corp

**Silencers/Mufflers**

BRD Noise & Vibration Control Inc  
 DeMarco MAX VAC Corp  
 EPG Companies Inc  
 NAO Inc  
 United McGill Corp

**Site Assessment**

ABB Environmental Services Inc  
 AE Environmental Services Inc  
 ASTM  
 ATEC Associates Inc  
 ATI  
 Adironack Environmental Associates Inc  
 Air Science Consultants  
 Alton Geoscience  
 Applied Science & Technology Inc  
 Arthur D Little Inc  
 Atlantic Testing Laboratories Limited  
 BEM Systems Inc  
 Barr Engineering Co  
 Bioscience Inc  
 Blasland Bouck & Lee Inc  
 Braun Intertec Corp  
 Brown & Root Environmental  
 CTL Environmental Services  
 Carnov, Conibear & Associates Ltd  
 ChemCycle Corp  
 Chemical Information System  
 Climatronics Corp  
 Corbus A Div of CMS Inc  
 Corporation for Environmental  
 Management  
 Dames & Moore  
 Deeco Inc  
 Detail Associates Inc  
 ENSCI Environmental Inc  
 ERM Group, The  
 Ecotech Inc  
 Enercon Services Inc  
 Enviro-Sciences Inc  
 Environmental Data Resources Inc  
 Environmental Health & Engineering Inc  
 Environmental Products & Services Inc  
 Environmental Resource Center  
 Environmental Technologies Group  
 FBA Environmental Inc  
 Foppe Thelen Group Inc  
 Foster Wheeler Environmental Corp  
 Foth & Van Dyke

Galson Corp  
 Gannett Fleming Inc  
 Geo-Technology Associates Inc  
 Geotrans Inc  
 Graef Anhalt Schloemer  
 Haley & Aldrich Inc  
 Hart Crowsier Inc  
 Haz Mat Containment Corporation  
 Heritage Environmental Services Inc  
 Hill International Inc  
 Hydro Group  
 International Engineers Inc  
 International Technology Corp  
 L Robert Kimball & Associates  
 LEXICON Environmental Associates Inc  
 Mabbett & Associates Inc  
 Morrison, Knudsen Corp  
**National Technical Systems Inc**  
**SEE AD ON PAGE 17**  
 Normandeau Associates, RMC  
 Environmental Services Div  
 O'Brien & Gere Technical Services Inc  
 PDG Environmental Inc  
 Parsons Engineering Science Inc  
 Professional Service Industries Inc  
 R E Wright Associates Inc (REW)  
 RMT Inc  
 Radian Corp  
 Raytheon Engineers &  
 Constructor/Raytheon Enviro Svc  
 Recon Environmental  
 Rollins Environmental  
 Rust Environment & Infrastructure  
 Rust International Inc  
 SSM/Spotts Stevens & McCoy Inc  
 Sensidyne Inc  
 Sewall, James W Co  
 Spectraserv  
 Stanley Consultants Environmental Inc  
 Stearns & Wheeler  
 Sverdrup Environmental Inc  
 TRAK Environmental Group Inc  
 Terra Bio Chem Environmental &  
 Engineering Services Inc  
 Traverse Group, The  
 Vamco Engineering Group  
 Versar Inc  
**Vertek**  
**SEE AD ON PAGE 61**  
 W L Gore & Associates Inc  
 Walk, Haydel & Associates Inc

**SALEM ENGELHARD**  
**313-437-1400**  
**Salem Enghard**  
**SEE AD ON PAGE 119**  
 Smith & Loveless Inc

**Williams Knowledge Systems Inc**  
**SEE AD ON PAGE 9**  
 Wonder Makers Inc

**Sludge Blanket Level**

Automation Products Inc  
 Fluid Components Int'l  
 Inventron Inc

**Sludge Concentrating Equipment**

Accurate Industries  
**ANDRITZ**  
**817-465-5611**  
 Andritz Ruthner Inc  
 Ashbrook Corp  
 Automation Products Inc  
 Brown Bear Corp  
 EIMCO Process Equipment Co  
 Envirex  
 Fluidyne Corp  
 Great Lakes Environmental Inc  
 Heyl & Patterson Inc  
 IPEC Industries  
 Industrial Filter & Pump Mfg Co

**JMI**  
**1-800-214-1682**

JWI  
 Kamline Sanderson  
 MEC Co  
 Netzsich Inc  
 Portec Construction Equip Div  
 Resources Conservation Co

**SALEM ENGELHARD**  
**313-437-1400**

**Salem Enghard**  
**SEE AD ON PAGE 119**  
 Smith & Loveless Inc

**SWENSON**  
**708-331-5500**

Swenson Process Equipment Inc  
 Tenco Hydro Inc  
 Universal Process Equipment Inc  
 Western Filter Co

**Sludge Dewatering/Disposal Service**

ARD Environmental Inc  
 AWD Technologies Inc  
**Carylon Corp**  
**SEE AD ON PAGE**  
 Chester Environmental  
 Envirite Corp  
 Environmental Products & Services Inc  
 Hazen & Sawyer  
 Heritage Environmental Services Inc  
 International Technology Corp  
 O'Brien & Gere Technical Services Inc  
 Ogdan Environmental & Energy Services  
 Peoria Disposal Co  
 RMT Inc  
 Rollins Environmental  
 Rust Environment & Infrastructure  
 Rust International Inc  
 Severson Environmental Services Inc  
 Spectraserv  
 Sverdrup Environmental Inc  
 Trans-Enviro Inc

**Sludge Dewatering Equipment**

AFI Industries Inc  
 ARD Environmental Inc  
 Alar Engineering Corp

**ANDRITZ**  
**817-465-5611**

Andritz Ruthner Inc  
 Ashbrook Corp  
 Baker Tanks  
 Baler Equipment Co  
 Bird Machine Co Inc  
 Brown Bear Corp  
 Diagenex Inc  
 Discflo Corp  
 Duriron Co Inc, The  
 EIMCO Process Equipment Co  
 Envirex  
 Ferro Corp, Specialty Ceramics  
 Div/Filtros Plant  
 Frontier Technology Inc  
 Great Lakes Environmental Inc  
 Heyl & Patterson Inc  
 IPEC Industries  
 Industrial Filter & Pump Mfg Co

**JMI**  
**1-800-214-1682**

JWI  
 Koch Engineering Co Inc  
 Komline Sanderson  
 MEC Co  
 Netzsich Inc  
**Niro Inc**  
**SEE AD ON PAGE 51**

Oil Skimmers Inc  
 Or-Tec Inc  
 Paco Pumps  
 Parkson Corp  
 Quality Industries Inc  
 Resources Conservation Co  
 Rust International Inc  
 Sebright Products Inc  
 Serfilco Ltd  
 Severson Environmental Services Inc  
 Sharples, Business Unit of Alfa Laval  
 Separation  
 Smith & Loveless Inc  
 Star Systems Filtration Division/Hilliard  
 SC Inc  
 Stord Inc  
 United States Filter Corp  
 Universal Process Equipment Inc  
 Waste-Tech Inc  
 Winsor & Jerould  
 Zimpro Environmental Inc

**Sludge Management**

A O Smith Harvestore Products Inc  
 AE Environmental Services Inc  
 ARD Environmental Inc  
 Atlantic Testing Laboratories Limited  
**Carylon Corp**  
**SEE AD ON PAGE 66**  
 Chester Environmental  
 College Research Corp (CORECO)  
 Dames & Moore  
 Discflo Corp  
 EA Engineering, Science &  
 Technology Inc  
 ERM Group, The

**EPOLEON CORPORATION OF AMERICA**  
**1-800-EPOLEON**

**Epoleon Corp of America**  
**SEE AD ON PAGE 24**  
 FBA Environmental Inc  
 Foster Wheeler Environmental Corp  
 Foth & Van Dyke  
 Hazen & Sawyer  
 Heritage Environmental Services Inc  
 LEXICON Environmental Associates Inc

**LWT & PIT HOG**  
**1-800-243-1406**

**Liquid Waste Technology Inc**  
**SEE AD ON PAGE 35**  
 Nalco Chemical Co  
 O'Brien & Gere Technical Services Inc  
 Ogdan Environmental & Energy Services  
 Oil Skimmers Inc  
 Parsons Engineering Science Inc  
 R E Wright Associates Inc (REW)  
 RMT Inc  
 Rust Environment & Infrastructure  
 Rust International Inc  
 SRS Crisafulli Inc  
 SSM/Spotts Stevens & McCoy Inc  
 Severson Environmental Services Inc  
 Sewall, James W Co  
 Smith & Loveless Inc  
 Spectraserv  
 Sverdrup Environmental Inc  
 Traverse Group, The  
 Wheelabrator Clean Water Systems

Inc/Bio Gro Div  
 Zimpro Environmental Inc

**Sludge Solidification**

ABB Raymond  
 AWD Technologies Inc  
 Bioscience Inc  
 Brown & Root Environmental  
 Colloid Environmental Technologies Co  
 Enreco Inc  
 FERtech Environmental Inc  
 Gelok Intl Corp  
**Geo-Con Inc**  
**SEE AD ON PAGE 54**  
 Hankin Environmental Systems Inc  
 Hayward Baker Environmental  
 Heritage Environmental Services Inc  
 Heyl & Patterson Inc  
 International Technology Corp

**JMI**  
**1-800-214-1682**

JWI  
 MEC Co  
 Morrison, Knudsen Corp  
 Netzsich Inc  
 O'Brien & Gere Technical Services Inc  
 Peoria Disposal Co  
 Rust International Inc  
**Salem Enghard**  
**SEE AD ON PAGE 119**

**Severson Environmental Services, Inc.**  
**716-284-0431**

Severson Environmental Services Inc  
 Smith & Loveless Inc  
 Spectraserv  
 Trans-Enviro Inc  
 Zimmerman Industries Inc

**Slurry Cut-off Walls**

Brown & Root Environmental  
**Diversified Well Products Inc**  
**SEE AD ON PAGE 30**  
 EA Engineering, Science & Technology  
 Inc  
 Haley & Aldrich Inc  
 Hayward Baker Environmental  
 Heritage Environmental Services Inc  
 Integra Plastics Inc  
 International Technology Corp  
 Morrison, Knudsen Corp  
 O'Brien & Gere Technical Services Inc  
 R E Wright Associates Inc (REW)  
 Raytheon Engineers &  
 Constructor/Raytheon Enviro Svc  
 Rust Environment & Infrastructure  
 Rust International Inc

**Severson Environmental Services, Inc.**  
**716-284-0431**

Severson Environmental Services Inc

**Soil Gas/Groundwater Surveys**

ABB Environmental Services Inc  
 Adironack Environmental Associates Inc  
 Alliance Environmental Inc  
 American Scientific Instrumentation  
 Atlantic Testing Laboratories Limited  
 BEM Systems Inc  
 Ben Meadows  
 Blasland Bouck & Lee Inc  
 Bock Environmental Service Inc  
 Braun Intertec Corp  
 Brown & Root Environmental  
 Carnov, Conibear & Associates Ltd

# Your Environmental Insurer's Motto

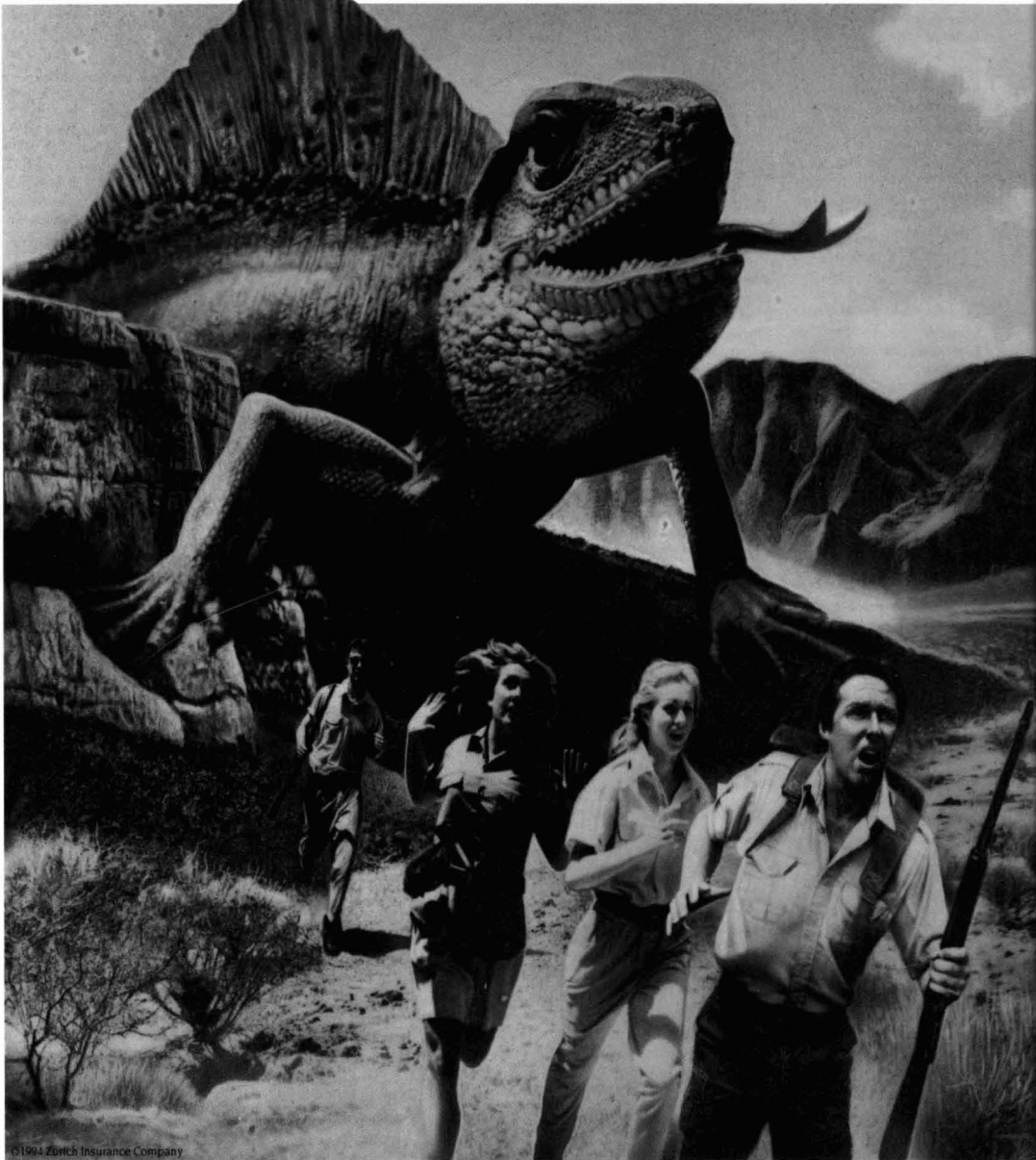

© 1994 Zurich Insurance Company

Today, you need the courage and creativity that our specialists have shown since the days when they pioneered the industry. You need an ever-evolving company willing to take the intelligent, informed risks that progressive risk management demands.

By forming an active partnership with our agents, brokers and customers, the Zurich-American Environmental Group forges a bond of shared expertise that recognizes no boundaries when it comes to creative risk management products and solutions. We're willing to take

**The Power of Partnership™ in Environ**

# Shouldn't Be "Run For Your Lives."

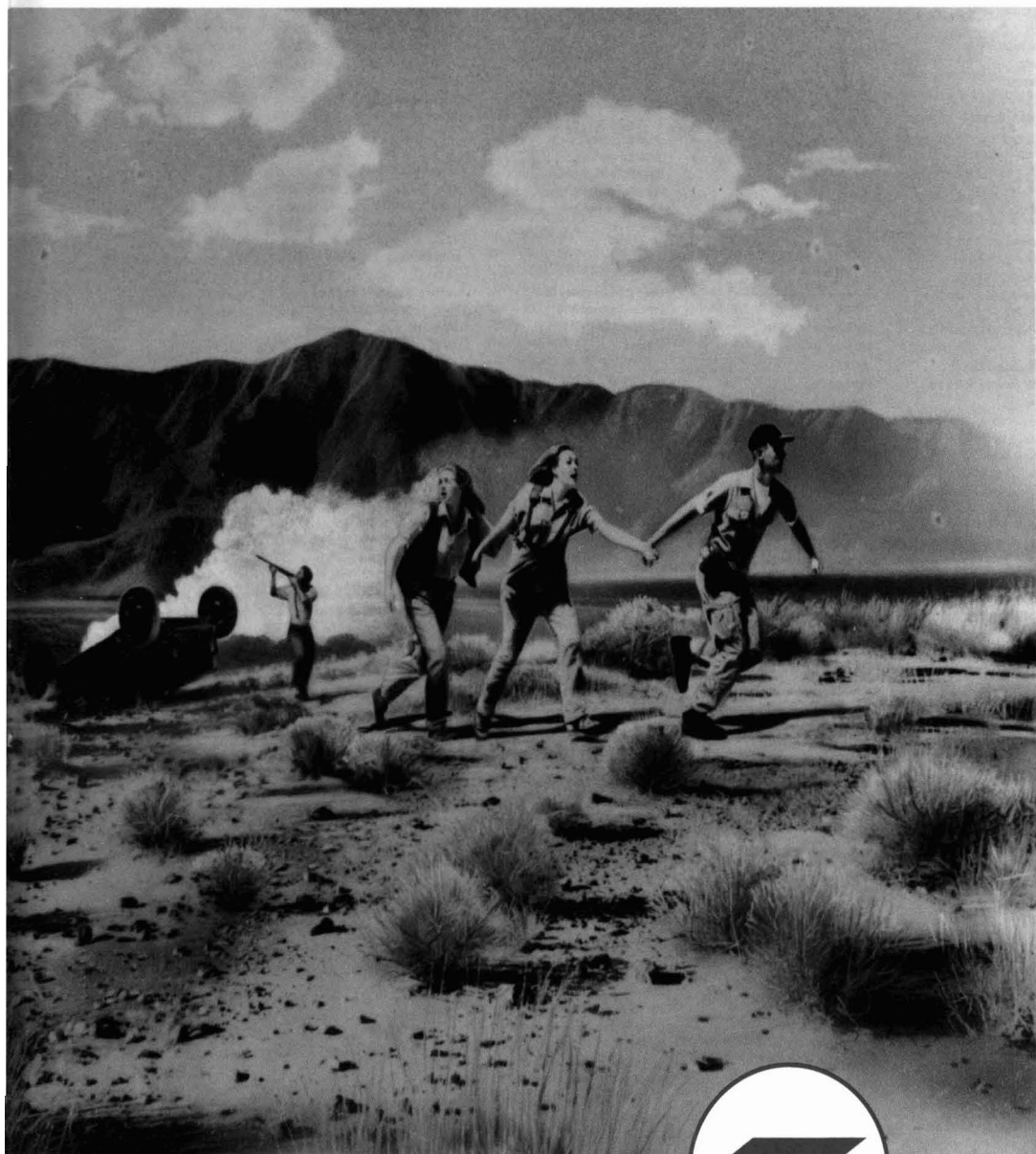

risks other companies won't. And we'll service our policies in a way other companies can't. Because we're backed by the financial strength, stability and The Power of Partnership only The Worldwide Zurich Insurance Group can provide. For more information, contact your agent or broker, or call 1-800-382-2150.



**ZURICH-AMERICAN  
INSURANCE GROUP**

**mental insurance**

A MEMBER OF THE WORLDWIDE



ZURICH INSURANCE GROUP

Circle 82 on card.

ChemCycle Corp  
 Chester Environmental  
**Commercial Dexterity**  
 SEE AD ON PAGE 64  
 Consulting Environmental Engineerings  
 Inc  
 Corporation for Environmental  
 Management  
 Dames & Moore  
 Deeco Inc  
 EA Engineering, Science & Technology  
 Inc  
 ENSCI Environmental Inc  
 ERM Group, The  
 ERM-South Inc  
 Eckenfelder  
 Ecotech Inc  
 Enviro-Sciences Inc  
 Environmental Standards Inc  
 FBA Environmental Inc  
 Foster Wheeler Environmental Corp  
**Foxboro Co, The**  
 SEE AD ON PAGE 46

Geotrans Inc  
 Global Environmental Inc  
 Groundwater Service & Supply Inc  
 Hart Crowser Inc  
 HazWaste Technologies Corp  
 Hill International Inc  
 International Engineers Inc  
 International Technology Corp  
 Keating Environmental Management Inc  
 L Robert Kimball & Associates  
 LEXICON Environmental Associates Inc  
 Linkmark Engineering Inc  
 Mabbett & Associates Inc  
 Morrison, Knudsen Corp  
**National Technical Systems Inc**  
 SEE AD ON PAGE 17  
 Normandeau Associates, RMC  
 Environmental Services Div  
 Northeast Research Institute (NERI)  
 Ogdon Environmental & Energy Services  
 Oxford Environmental Inc  
 Parsons Engineering Science Inc  
 Professional Service Industries Inc  
 R E Wright Associates Inc (REW)  
 RMT Inc  
 Radian Corp  
 Recon Environmental  
 Rollins Environmental  
 Rust Environment & Infrastructure  
 Rust International Inc  
 Sensidyne Inc  
 Superior Environmental Corp  
 Sverdrup Environmental Inc  
 TRAK Environmental Group Inc  
 Terra Bio Chem Environmental &  
 Engineering Services Inc

**Tracer Research Corporation**  
 1-800-394-9929

Tracer Research Corp  
 Traverse Group, The  
 W L Gore & Associates Inc

**Soil Sampling Equipment**

Alliance Environmental Inc  
 American Scientific Instrumentation

**Art's Manufacturing & Supply (AMS)**  
 1-800-635-7330

Art's Manufacturing & Supply (AMS)  
 SEE AD ON PAGE 53  
 Associated Design & Mfg  
 Atlantic Screen & Mfg Inc  
 Ben Meadows  
**Clements Associates Inc**  
 SEE AD ON PAGE 34  
**Commercial Dexterity**  
 SEE AD ON PAGE 64

**Diversified Well Products Inc**  
 SEE AD ON PAGE 30  
 ELE International Inc/Soiltest  
 Products Div  
 Ensys Environmental Products Inc  
 Environmental Industrial Resources  
**Foxboro Co, The**  
 SEE AD ON PAGE 46  
 General Analysis Corp  
 Hazco Services Inc  
**Health Consultants Inc**  
 SEE AD ON PAGE 142  
**Horiba Instruments Inc**  
 SEE AD ON PAGE 44  
 Intek Corp/Rent-Alyzer

**INERVOLOG**  
 System Specification Specialists  
 1-800-433-8487

Intervac  
 LINC Quantum Analytics  
 Lab Safety Supply  
 Myron L Co  
 NovaLynx Corp  
**Omega Engineering Inc**  
 SEE AD ON PAGE 2  
**Photovac Monitoring Instruments**  
 SEE AD ON PAGE 42  
 R E Wright Associates Inc (REW)  
 Sensidyne Inc  
 Superior Environmental Corp  
**Vertek**  
 SEE AD ON PAGE 61

**Solvent Recovery Systems**

ABB Raymond  
 AGA Gas Inc  
 APV Heat Transfer/Separation  
 Technologies  
 Activated Carbon Technology  
**Adwest Technologies Inc**  
 SEE AD ON PAGE 36  
 Airex Div Adwest Technologies  
 American Environmental International Inc  
 Anguil Environmental Systems Inc  
 Automation Products Inc  
 Barnebey & Sutcliffe Corp  
 Calgon Carbon Corp  
 Ducon Environmental Systems Inc  
 ELE International Inc/Soiltest Products  
 Div  
 EPG Companies Inc  
 ERM-South Inc  
 Environmental Recovery Resources Inc  
 Finish Thompson Inc  
 General Carbon Corp  
**Horiba Instruments Inc**  
 SEE AD ON PAGE 44  
 Integrated Chemistries Inc  
 International Technology Corp

**INERVOLOG**  
 System Specification Specialists  
 1-800-433-8487

Intervac  
 Membrane Technology & Research Inc  
**Met-Pro Corp Systems Div**  
 SEE AD ON PAGE 43  
 Morrison, Knudsen Corp  
 National Environmental Systems Inc  
 O'Brien & Gere Technical Services Inc  
 ORS Environmental Systems  
 Phenomenex  
 Pope Scientific  
 Purus Inc  
 QED GroundWater Specialists  
 R E Wright Associates Inc (REW)  
 Recon Environmental  
 Rust Environment & Infrastructure  
 Rust International Inc

**Safety-Kleen**  
 1-800-323-5040

Safety Kleen Corp  
 Servomex Co Inc  
 Sharples, Business Unit of Alfa Laval  
 Separation  
 Stokes Vacuum Inc  
 Tedder & Widhelm Consultants Inc  
 21 EMU/Elicam  
 Universal Process Equipment Inc  
 Vacuum Engineering  
 Vara Intl Div of Calgon Carbon Corp  
 Vector Technologies Ltd  
 Wheelabrator Environmental  
 Systems Inc

**Sonic Cleaning Devices**

Cole-Parmer Instrument Co  
 Lab-Line Instruments Inc  
 Midwesco Filter Resources Inc  
 Misonix Inc

**Speed Reducers**

**AA Applied Automation**  
 Hartmann & Braun  
 918-662-7343

Applied Automation/Hartman & Braun  
 SEE AD ON PAGE 164  
 Boston Gear  
 Sew Eurodrive

**Spill Control Equipment/Products/Services**

AFL Industries Inc  
 Adironack Environmental Associates Inc  
 Agar Corp  
 American EnviroSpect Inc

**Art's Manufacturing & Supply (AMS)**  
 1-800-635-7330

Art's Manufacturing & Supply (AMS)  
 SEE AD ON PAGE 53  
 Baker Tanks  
 Bergen Barrel & Drum  
 Bioscience Inc  
 C2T Group Ltd

**CHEM-TAINER**  
 INDUSTRIES, INC.  
 1-800-275-2436

Chem-Tainer Industries  
 Chester Environmental  
 Conwed Environmental  
 Dames & Moore  
 DeMarco MAX VAC Corp  
 Dival Safety Equipment  
 Drexelbrook Engineering Co  
 EA Engineering, Science &  
 Technology Inc  
 Edwards & Cromwell Mfg Inc  
 Enercon Services Inc  
 Environmental Container Corp  
 Environmental Industrial Resources  
 Environmental Products & Services Inc  
 Environmental Resource Center  
**Environmental Restoration**  
**Systems Inc**  
 SEE AD ON PAGE 18

**Enviropack**  
 800-423-8188

Enviropack  
 Fisher Scientific Safety Products Div  
 Foster Wheeler Environmental Corp  
 G O Environment Inc  
 Gelok Intl Corp

Geraghty & Miller Inc A Heidemij Co  
 Godwin Pumps of America Inc  
 Groundwater Technology Inc  
 Guzzler Mfg Inc  
 Hart Crowser Inc  
 Hazco Services Inc  
 Heritage Environmental Services Inc  
 Hudson Industries  
 Hyde Products Inc  
 ILC Dover Inc  
 Integra Plastics Inc  
 Integrated Chemistries Inc  
 International Technology Corp  
 JT Baker Chemical Inc  
 Labelmaster  
 Lincoln Automotive  
 Linkmark Engineering Inc  
 LMSA  
 Mole Master Services Corp  
 National Environmental Systems Inc  
**National Technical Systems Inc**  
 SEE AD ON PAGE 17  
 Nautus Inc  
**New Pig Corp**  
 SEE AD ON PAGE 138

Nuclear Associates  
 O'Brien & Gere Technical Services Inc  
 Ogdon Environmental & Energy Services  
 Oil Skimmers Inc  
 Price-Darnall Inc of Alabama  
 R E Wright Associates Inc (REW)  
 Reef Industries Inc  
 Reliance Electric Co  
 Remco Products Corp  
 Safe Environmental Storage Corp  
**Safety Storage Inc**  
 SEE AD ON PAGE 70

Sensidyne Inc  
 Serengeti Environmental  
 Sikwik Sorbents  
 Soil & Material Engineers Inc  
 Spectrum Chemical & Safety Products  
 Sunshine Technology Corp  
 Terra Bio Chem Environmental &  
 Engineering Services Inc  
 Total Containment Inc  
 Ultratech International  
 Vacuum Engineering  
 Vector Technologies Ltd  
**Williams Knowledge Systems Inc**  
 SEE AD ON PAGE 9  
 Wolfco Group Inc  
 Youngstown Barrel & Drum Co

**Spraying Equipment**

Amadas Industries  
 American Gas Products Inc  
 Chemco Mfg Co Inc  
 Cole-Parmer Instrument Co  
 Dival Safety Equipment  
 Finn Corp  
 Godwin Pumps of America Inc  
 Haz-Stor Co  
 Hazco Services Inc  
 Landa Inc  
 Lecher Inc  
 Misonix Inc  
 NAO Inc  
 Spraying Systems Co

**Stack Emission Monitors**

Air Instruments & Measurements Inc  
 Ametek Inc  
 Ametek P & AI Div  
 Anarad Inc  
**Auburn International Inc**  
 SEE AD ON PAGE 53  
 Bacharach Inc  
 Bailey Controls Co  
 CAE Instrument  
 CAE Express Rental  
 Clean Air Engineering  
 Foster Wheeler Environmental Corp  
 Columbia Science Industries Co  
 Columbia Scientific

Dancer Communications Inc  
 Datastat Corp  
 Dyna-Fid Inc  
 Ecom America Ltd  
 Entech Instruments Inc  
 Environmental Compliance Systems Corp  
 Environmental Energy Services Inc (EES)  
 Environmental Monitor Systems Inc  
 Environmental Techniques  
 Environmental Technologies Group

**ENVIROPLAN**  
 201-994-2300

Enviroplan Inc  
 Fluid Components Intl  
 Fluid Data Inc  
**HI-Q Environmental Products Co**  
 SEE AD ON PAGE 47  
 Hazco Services Inc  
**Horiba Instruments Inc**  
 SEE AD ON PAGE 44  
 Hull Corp Environmental Products Div  
 Insitex Inc  
 Intek Corp/Rent-Alyzer  
 Jeca Corp  
 McNeill International  
 Midac Corp  
 Midwesco Filter Resources Inc  
 Monarch Instrument  
 Monitor Labs Inc  
 Nova Analytical Systems Inc  
 OI Analytical  
 PACE Environmental Products  
 Panametrics PCI Div  
 Perkin-Elmer Corp  
 Response Rentals  
 Rosemount Analytical Inc  
 Serdex Systems Inc  
 Servomex Co Inc  
 Siemens Industrial Automation Inc  
 Sixmet  
 Teledyne Brown Engineering/Analytical  
 Instruments  
 Terra Bio Chem Environmental &  
 Engineering Services Inc  
 Thermo Environmental Instruments  
 United Sciences Inc  
 Wheelabrator Environmental  
 Systems Inc  
 Zink, John Co Div of Koch  
 Engineering Co Inc

**Stack Emission Testing**

ADA Technologies Inc  
 AWD Technologies Inc

**AA Applied Automation**  
 Hartmann & Braun  
 918-662-7343

Applied Automation/Hartman & Braun  
 American Scientific Instrumentation  
 Bacharach Inc  
 Barr Engineering Co  
 Braun Intertec Corp  
 Brown & Root Environmental  
 Burns & McDonnell  
 CTL Environmental Services  
 Center for Hazardous Materials Research  
 Clean Air Engineering  
 Corporation for Environmental  
 Management  
 Dames & Moore  
 ERM Group, The  
 Enercon Services Inc  
**Energy Efficiency Systems Inc**  
 SEE AD ON PAGE 11  
 Entropy Inc  
 Enviro-Sciences Inc  
 Environmental Techniques  
 Environmental Technologies Group  
 Galson Corp  
 Gascoyne Laboratories Inc

## HI-Q Environmental Products Co

SEE AD ON PAGE 47

Hart Crowser Inc  
International Technology Corp  
K & B Design Inc  
L Robert Kimball & Associates  
**Lancaster Laboratories Inc**

SEE AD ON PAGE 7

METCO Environmental  
MMT Environmental Services Inc  
Mabbett & Associates Inc  
Midwestco Filter Resources Inc  
Natisco  
Ogden Environmental & Energy Services  
Pacific Analytical Inc  
Parsons Engineering Science Inc  
Perkin-Elmer Corp  
R E Wright Associates Inc (REWI)  
RMT Inc  
Raytheon Engineers &  
Constructor/Raytheon Enviro Svc  
Raytheon Engineers &  
Constructor/Raytheon Enviro Svc  
Recon Environmental  
Rust Environment & Infrastructure  
Rust International Inc  
SSM/Spotts Stevens & McCoy Inc  
Sentex Systems Inc  
Servomex Co Inc

**TENERX CORP.**  
713-482-5801

Tenex Corp  
Terra Bio Chem Environmental &  
Engineering Services Inc  
Whatman Inc  
Wheelabrator Environmental  
Systems Inc

## Stack Flow Meters

Anarad Inc  
CAE Express  
CAE Instrument Rental  
Clean Air Engineering  
Columbia Scientific  
**Dieterich Standard, a Dover Industries Co**

SEE AD ON PAGE 64

Fluid Components Intl

## HI-Q Environmental Products Co

SEE AD ON PAGE 47

ModuTank Inc  
**Omega Engineering Inc**  
SEE AD ON PAGE 2  
Parametrics PCI Div  
Parsons Engineering Science Inc  
Thermo Environmental Instruments  
United Sciences Inc  
Wheelabrator Environmental  
Systems Inc

## Standards

ASTM  
AccuStandard Inc  
Environmental Resource Associates

**HACH**  
ISO 9001 Certified  
800-227-4224

Hach Co  
Inorganic Ventures Inc  
Keco R & D Inc  
Kin-Tek  
Liquid Carbonic  
NSI Environmental Solutions Inc  
Spectrum Chemical & Safety Products  
Structure Probe Inc/SPI Supplies  
Ultra Scientific Inc

## Sterilizers

Atlantic Ultraviolet Corp  
Capital Controls Co Inc

## Stormwater Monitoring

ABB Environmental Services Inc  
ADS Environmental Services Inc  
ATEC Associates Inc  
Adronckad Environmental Associates Inc  
Admiral Environmental Services Inc  
Agar Corp  
American Sigma Inc  
Applied Science & Technology Inc  
Atlantic Testing Laboratories Limited  
BEC Laboratories  
BEM Systems Inc  
**Badger Meter Inc**

SEE AD ON PAGE 4

Barr Engineering Co  
Braun Intersect Corp  
CET Environmental Services Inc  
CHEMetrics Inc  
CTL Environmental Services  
Campbell Scientific Inc  
Carnow, Conbar & Associates Ltd  
ChemCycle Corp  
Chester Environmental  
Climatronics Corp  
Consulting Environmental Engineers Inc  
Corporation for Environmental  
Management  
Dames & Moore  
Deeco Inc  
E S E Bioscience  
EA Engineering, Science & Technology  
Inc

ENSCI Environmental Inc  
ERM Group, The  
ERM-South Inc  
Eckentelder  
Ecotech Inc  
Enercon Services Inc  
Enviro-Sciences Inc  
Environmental Recovery Resources Inc  
FBA Environmental Inc  
Foster Wheeler Environmental Corp  
Gannett Fleming Inc  
Gascayne Laboratories Inc  
Geo-Technology Associates Inc  
Global Water  
Groundwater Technology Inc

**HACH**  
ISO 9001 Certified  
800-227-4224

Hach Co  
Hart Crowser Inc  
HazWaste Technologies Corp  
Hazen & Sawyer  
Heritage Environmental Services Inc  
Intec Controls Corp  
Invalco Inc  
Inventron Inc  
Isco Inc Environmental Div  
Kennedy/Jenks Consultants  
L Robert Kimball & Associates  
Lindmark Engineering Inc  
Mabbett & Associates Inc  
Monarch Instrument  
Normandeau Associates, RMC  
Environmental Services Div  
Ogden Environmental & Energy Services  
**Omega Engineering Inc**

SEE AD ON PAGE 2

Parsons Engineering Science Inc  
R E Wright Associates Inc (REWI)  
RGF Environmental Systems Inc  
RMT Inc  
Raytheon Engineers &  
Constructor/Raytheon Enviro Svc  
Remco Engineering  
Remedial Systems Inc  
Rust Environment & Infrastructure  
Rust International Inc  
SSM/Spotts Stevens & McCoy Inc  
Sewall, James W Co  
Spectraserv  
Sverdrup Environmental Inc  
Terra Bio Chem Environmental &  
Engineering Services Inc  
3M Filtration Products  
Trans-Enviro Inc

Sewall, James W Co  
Solomat  
Spectraserv  
Spectrogram Corp  
Superior Signal Co Inc  
Sverdrup Environmental Inc  
Terra Bio Chem Environmental &  
Engineering Services Inc  
Tracom Inc  
Trans-Enviro Inc  
Traverse Group, The  
Wellington Environmental Consulting &  
Construction Inc

## Stormwater Treatment

ARD Environmental Inc  
Andco Environmental Processes Inc  
Atlantic Testing Laboratories Limited  
BioTrol Inc  
Blasland Bouck & Lee Inc  
Brown & Root Environmental  
Carbonair Environmental Systems  
Chester Environmental  
Colloid Environmental Technologies Co  
Consulting Environmental Engineers Inc  
Dames & Moore  
Deeco Inc  
Disclfo Corp  
E S E Bioscience  
EA Engineering, Science & Technology  
Inc

EPG Companies Inc  
ERM Group, The  
Eckentelder  
Environmental Recovery Resources Inc  
Ferrick Construction Co Inc  
Foster Wheeler Environmental Corp  
General Carbon Corp  
Great Lakes Environmental Inc  
Groundwater Technology Inc  
H2 Oil Recovery Equipment Inc  
Hart Crowser Inc  
Hazen & Sawyer  
Hazleton Environmental  
Heritage Environmental Services Inc  
Highland Tank

Infiltrator Systems Inc  
Intec Controls Corp  
L Robert Kimball & Associates  
Mabbett & Associates Inc  
Monarch Separators Inc  
Nautus Inc  
O'Brien & Gere Technical Services Inc  
**Omega Engineering Inc**

SEE AD ON PAGE 2

Parsons Engineering Science Inc  
R E Wright Associates Inc (REWI)  
RGF Environmental Systems Inc  
RMT Inc  
Raytheon Engineers &  
Constructor/Raytheon Enviro Svc  
Remco Engineering  
Remedial Systems Inc  
Rust Environment & Infrastructure  
Rust International Inc  
SSM/Spotts Stevens & McCoy Inc  
Sewall, James W Co  
Spectraserv  
Sverdrup Environmental Inc  
Terra Bio Chem Environmental &  
Engineering Services Inc  
3M Filtration Products  
Trans-Enviro Inc

**TAMCO**  
817-799-5546

Tymco Inc  
SEE AD ON PAGE 65

Unipure Environmental  
SEE AD ON PAGE 10

United States Filter Corp  
Zimpro Environmental Inc

## Strainers

Air Plastics Inc  
**Badger Meter Inc**  
SEE AD ON PAGE 4  
Durion Co Inc, The  
Lycro Manufacturing Inc  
Specialty Mfg Co, The  
Sprey Systems Co  
Wheelabrator Environmental  
Systems Inc  
Ziamatic Corp

## Sulfate/Sulfide Detectors

CEA Instruments  
California Analytical Instruments Inc  
Dasibi Environmental Corp  
Dival Safety Equipment  
Hazzo Services Inc  
International Sensor Technology  
Sierra Monitor Corp  
Wheelabrator Environmental  
Systems Inc

## Sulfur Dioxide

Air Instruments & Measurements Inc  
Anarad Inc  
Bacharach Inc  
Biosystems  
Climatronics Corp  
Columbia Science Industries Co  
Columbia Scientific

**Control Instruments Corporation**  
201-575-9114

Control Instruments Corp  
Dasibi Environmental Corp  
Dival Safety Equipment  
**Energy Efficiency Systems Inc**  
SEE AD ON PAGE 11  
Environmental Energy Services Inc (EES)  
Environmental Monitor Systems Inc  
**Foxboro Co, The**  
SEE AD ON PAGE 46

G E Co  
Hazzo Services Inc  
Monitor Labs Inc  
Noxso Corp  
Sensor Electronics Corp  
Stanley Consultants Inc  
Thermo Environmental Instruments  
**Wallace & Tiernan Inc**  
SEE AD ON PAGE 29

## Sulfur Oxide Detectors

Air Instruments & Measurements Inc  
Ametek Inc  
Anarad Inc  
CAE Express  
CEA Instruments  
Columbia Science Industries Co  
Dasibi Environmental Corp  
Dival Safety Equipment  
EIT  
ENMET Corp  
Environmental Compliance Systems Corp  
Hazzo Services Inc  
**Horiba Instruments Inc**  
SEE AD ON PAGE 44

Industrial Scientific Corp  
Intek Corp/Plant-Allyzer  
International Sensor Technology  
McNeill International  
Neotronics  
Nova Analytical Systems Inc  
Rosemount Analytical Inc  
Scott Aviation, A Figgie Intl Co  
Sensidyne Inc  
Sierra Monitor Corp  
Spectrum Chemical & Safety Products  
Thermo Environmental Instruments  
**Wallace & Tiernan Inc**  
SEE AD ON PAGE 29

Wheelabrator Environmental  
Systems Inc

## Suspended Solids Instrumentation

Automation Products Inc  
Hazzo Services Inc  
Instrumark International  
Parsons Engineering Science Inc

## Sweepers, Air Sweepers

**ELGIN**  
708-741-5370

Elgin Sweeper Co

**TAMCO**  
817-799-5546

Tymco Inc  
SEE AD ON PAGE 65

## Sweepers, In Plant Sweepers

Advance Machine Co

**ELGIN**  
708-741-5370

Elgin Sweeper Co  
Measurement & Flow Control

**TAMCO**  
817-799-5546

Tymco Inc  
SEE AD ON PAGE 65

## Sweepers, Truck Mounted - In Plant

**ELGIN**  
708-741-5370

Elgin Sweeper Co

**TAMCO**  
817-799-5546

Tymco Inc  
SEE AD ON PAGE 65

## Tanks

A O Smith Harvestore Products Inc  
ATI  
Advanced Polymer Sciences Inc  
Air Plastics Inc  
American EnviroSpect Inc

**AmfueI** 501-235-7297  
American Fuel Cell and Coated Fabrics Company

AmfueI  
Aero-Power Utilized Fueler Inc  
Assman Corp of America  
Atlas Minerals & Chemicals Inc  
BEM Systems Inc  
Baker Tanks  
Bergen Barrel & Drum  
Brown Minneapolis Tank  
CMI-Schnelble Co  
Carbon Activated



Chem-Tainer Industries



Columbian Steel Tank  
Dancer Communications Inc  
Denver Mineral Engineers Inc  
EPG Companies Inc  
ERM Group, The  
Environetics Inc  
Environmental Products & Services Inc  
Envirovision Group Inc, The



Fabrico Environmental Liners Inc  
Ferrick Construction Co Inc  
Fluidyne Corp  
Gurman Container & Supply Corp  
Highland Tank  
Huntingdon Engineering & Environmental Inc  
Marshall Industrial Technologies  
Met-Pro Corp Systems Div

SEE AD ON PAGE 43

ModuTank Inc  
Monarch Separators Inc  
Morehouse-Cowles Inc  
Nalge Co  
Owens Corning  
Plexco  
Pope Scientific  
RMJ Machinery Inc  
Steel Tank Association  
Tank Industry Consultants Inc  
Total Containment Inc  
Ultratech International  
United States Filter Corp  
Universal Process Equipment Inc  
Youngstown Barrel & Drum Co

**TCLP**

ACTS Testing Labs Inc  
ASTB/Analytical Services Inc  
Aaron Environmental Services Corp  
American Standards Testing Bureau Inc  
Applied Research & Development Lab  
Associated Design & Mfg  
Atlantic Testing Laboratories Limited  
B & W NESI NEL  
BEC Laboratories  
Chester Environmental  
Clean Venture/Cycle Chem  
Compu Chem Environmental Corp  
Con-Test  
EA Engineering, Science & Technology Inc  
ENSCI Environmental Inc  
Eco Tek Laboratory Services Inc  
Enreco Inc  
Environmental Products & Services Inc  
Foppe Thelen Group Inc  
Gascoyne Laboratories Inc  
H E S Inc  
Heritage Environmental Services Inc  
**Lancaster Laboratories Inc**  
SEE AD ON PAGE 7  
Nytel Environmental Inc  
Pacific Analytical Inc  
Trans-Enviro Inc  
Trinity Environmental Technologies  
Waste Stream Technology Inc  
Whatman Inc

**Telemetry Systems**

Bristol Babcock Inc  
Campbell Scientific Inc

Carbonair Environmental Systems  
Climatronics Corp  
Dancer Communications Inc  
EG & G Marine Instruments  
EPG Companies Inc  
**Environmental Restoration Systems Inc**  
SEE AD ON PAGE 18

Global Water



H2NS Environmental  
Handar  
Hans Environmental Inc  
National Environmental Systems Inc  
Norris Technologies Inc  
NovaLynx Corp  
ORS Environmental Systems  
Pace Transducer/CJ Enterprise  
Phonetics Inc  
Schneider Instrument Co  
Telog Instruments Inc  
Vital Inc  
YSI Inc

**Temperature Instrumentation**

A I W Inc



Art's Manufacturing & Supply (AMS)  
SEE AD ON PAGE 53

Automatic Switch Co (ASCO)  
Bacharach Inc  
Bailey Controls Co  
Bailey-Fischer & Porter Co  
Barnart Co  
Ben Meadows  
Bristol Babcock Inc  
Brooklyn Thermometer Co Inc  
CAE Express  
Campbell Scientific Inc  
Coastal Leasing Inc  
Dickson Co, The  
Dival Safety Equipment  
Dwyer Instruments Inc  
Engelhard Corp  
Everest Interscience Inc  
G E Co  
Geoguard Inc  
Handar  
Hazco Services Inc  
**Hydrolab Corp**

SEE AD ON PAGE 22

Instruments Direct Inc



MMC Intl Corp  
SEE AD ON PAGE 23

Met-One Instruments Inc  
SEE AD ON PAGE 26

Monarch Instrument  
National Instruments  
Neslab Instruments Inc  
Newport Electronics Inc  
NovaLynx Corp  
**Omega Engineering Inc**  
SEE AD ON PAGE 2  
Pace Transducer/CJ Enterprise  
Phonetics Inc  
**R M Young Co**  
SEE AD ON PAGE 47

TSI Inc/Environmental Measurements & Controls Div  
Tel-Tru Mfg Co  
Telog Instruments Inc  
Thornton Associates Inc

Universal Enterprises Inc  
Wavelek Corp  
YSI Inc

**Test Kits/Services**

AE Environmental Services Inc  
Ben Meadows  
Bioscience Inc  
CHEMetrics Inc  
Chem-Test Corp  
Climatronics Corp  
Compu Chem Environmental Corp  
Dexsil Corp  
Dwyer Instruments Inc  
ELE International Inc/Soiltest  
Products Div  
EM Science  
Ensys Environmental Products Inc  
Environmental Products & Services Inc  
G Q Environment Inc  
Group 206 Technologies Inc  
H E S Inc



Hach Co  
Hazco Services Inc  
JT Baker Chemical Inc  
MSA  
Orbeco Analytical Systems Inc  
Sensidyne Inc  
Spectrum Chemical & Safety Products  
Taylor Technologies  
Teledyne Brown Engineering - Environmental Services  
Wonder Makers Inc  
Yellow Logistics Services Inc

**Tire Combustion Equipment**

Leslie Mfg Inc

**TOC Detectors**

Anatel Corp  
Columbia Science Industries Co  
Cosmos Gas Detection  
Intek Corp/Rent-Alyzer  
Keco R & D Inc  
LINC Quantum Analytics  
OI Analytical  
Rosemont Analytical  
Sensidyne Inc  
Siewers Instruments Inc

**Tools**

American Gas Products Inc  
Dival Safety Equipment  
Hazco Services Inc  
Remco Products Corp  
Ridge Tool Co  
Soltec Corp

**Total Carbon Detectors**

Control Instruments Corp  
Cosmos Gas Detection  
Dival Safety Equipment  
Hazco Services Inc  
Sensidyne Inc

**Total Nitrogen Analyzers**

Ametek Inc  
Ametek P & AI Div  
Dasibi Environmental Corp  
Hazco Services Inc  
Orbeco Analytical Systems Inc  
Perkin-Elmer Corp  
Rosemont Analytical  
Sensidyne Inc

**Total Oxygen Demand**

Anatel Corp  
Hazco Services Inc  
Ionics Inc  
Orbeco Analytical Systems Inc  
Sensidyne Inc  
Waste Stream Technology Inc

**Total Sulfur Detectors**

Ametek Inc  
Ametek P & AI Div  
Columbia Science Industries Co  
Columbia Scientific  
Cosmos Gas Detection  
Dasibi Environmental Corp  
Dival Safety Equipment  
Hazco Services Inc  
International Sensor Technology  
OI Analytical  
Sensidyne Inc  
Universal Sensors & Devices Inc

**Toxic Gas Detectors**

AIM Safety USA Inc  
Air Instruments & Measurements Inc  
Airscon Environmental Technologies Inc  
Anarad Inc  
Ariel Industries Inc  
Arizona Instrument Corp  
Assay Technology Inc  
Bacharach Inc  
Bailey-Fischer & Porter Co  
Bascom-Turner Instruments  
Ben Meadows  
Biosystems  
Bruel & Kjaer Instruments  
CEA Instruments  
Capital Controls Co Inc  
Chem-Test Corp  
Cole-Parmer Instrument Co



Control Instruments Corp  
Cosmos Gas Detection  
Dival Safety Equipment



ENMET Corp  
Electrosynthesis Co  
Environmental Monitor Systems Inc  
Environmental Products & Services Inc  
Environmental Technologies Group  
Fisher Scientific Safety Products Div

**Foxboro Co, The**  
SEE AD ON PAGE 46

General Monitors  
Grace Industries Inc  
HNU Systems Inc  
Hazco Services Inc  
Industrial Scientific Corp  
Intek Corp/Rent-Alyzer  
International Sensor Technology  
LINC Quantum Analytics  
McNeill International  
Metrosonics Inc  
**Milco Safety Rental**  
SEE AD ON PAGE 64  
National Draeger Inc  
Neotronics

**Photovac Monitoring Instruments**  
SEE AD ON PAGE 42

Scott Aviation, A Figgie Intl Co  
Sensidyne Inc  
Sensor Electronics Corp  
Sentex Systems Inc  
Servomex Co Inc  
Sierra Monitor Corp  
Spectrum Chemical & Safety Products  
Teledyne Brown Engineering - Control

Applications  
Transducer Research  
Universal Sensors & Devices Inc  
Wheeler Environmental Systems Inc

**Toxicological Services**

ABB Environmental Services Inc  
AE Environmental Services Inc  
ASTB/Analytical Services Inc  
Alton Geoscience  
American Standards Testing Bureau Inc  
BEM Systems Inc  
Commonwealth Biomonitoring  
Dames & Moore  
EA Engineering, Science & Technology Inc  
ERM Group, The  
ERM-South Inc  
Eckenfelder  
Econer Services Inc  
Gascoyne Laboratories Inc  
Group 206 Technologies Inc  
Hart Crowler Inc  
HazWaste Technologies Corp  
L. Robert Kimball & Associates  
LEXICON Environmental Associates Inc  
Mabbett & Associates Inc  
Normandeau Associates, RMC  
Environmental Services Div  
O'Brien & Gere Technical Services Inc  
Ogden Environmental & Energy Services  
Radian Corp  
Rollins Environmental  
Rust International & Infrastructure  
Rust International Inc  
Sutobit/Durflow/Gardner Denver  
Sverdrup Environmental Inc  
Walk, Haydel & Associates Inc

**Tracer Products**

Bruel & Kjaer Instruments  
Crompton & Knowles Corp Industrial Products Div  
Envirovision Group Inc, The  
**Foxboro Co, The**  
SEE AD ON PAGE 46

**Training Services/Equipment**

A M A R C Inc (AIHMM)  
AE Environmental Services Inc  
ASTM  
ATC Environmental Inc  
BEM Systems Inc  
C2T Group Ltd  
CHEM-Tel Inc



COMCO Inc  
Center for Hazardous Materials Research  
Chester Environmental  
Con-Test  
Corporation for Environmental Management  
Covino Environmental Consulting Inc  
Dames & Moore  
ELB & Associates  
ERS Services  
Eastern Technical Associates  
Eckenfelder  
Enviro-Sciences Inc  
Environmental Education Enterprises Inc  
Environmental Health & Engineering Inc  
Environmental Products & Services Inc  
Environmental Resource Center  
**Environmental Restoration Systems Inc**  
SEE AD ON PAGE 18  
Haz Mat Containment Corporation



# GA-72CV Magnetic Locator detects 55-gal. steel drums buried up to 8 feet.

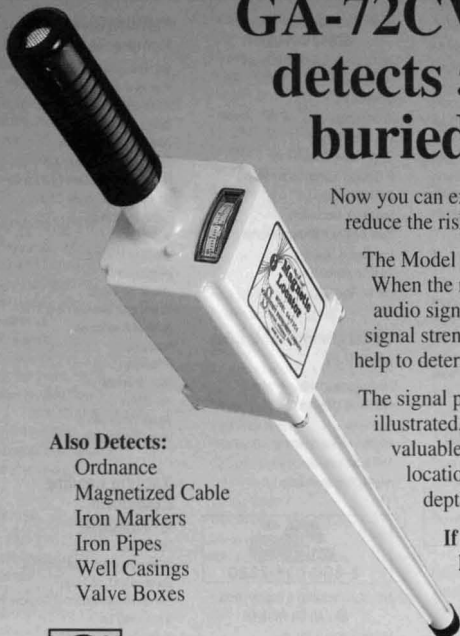

**Also Detects:**  
Ordnance  
Magnetized Cable  
Iron Markers  
Iron Pipes  
Well Casings  
Valve Boxes

Now you can expedite hazardous waste site assessment surveys and greatly reduce the risk of hitting buried drums while excavating.

The Model GA-72CV detects the magnetic field of iron and steel objects. When the magnetic field of a steel drum is detected, the locator's audio signal peaks over the barrel and the visual indication shows signal strength and polarity. These indications pinpoint the drum and help to determine its orientation.

The signal pattern indicates if the barrel is upright or laying on its side. As illustrated, the number of signal "peaks", their spacing and polarity provide valuable information on the location of steel barrels at depths up to 8 feet.

**If you're involved with  
Hazardous Waste Site  
Remediation, you need  
the Model GA-72CV.**

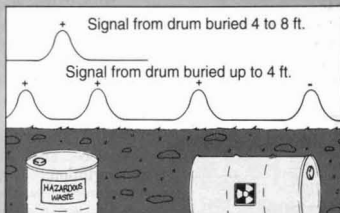

**S**  
**SCHONSTEDT INSTRUMENT COMPANY**

1775 Wiehle Avenue, Reston, VA 22090-5199 USA  
Phone (703) 471-1050 FAX (703) 471-1795

**DEALER  
INQUIRIES  
WELCOME**

**Circle 84 on card.**

Call 1-800-999-8280 for the dealer nearest to you, or to get your free applications brochure.

# Detect buried steel drums before your drill bit finds them.

Stop drilling every four feet. Withdraw the drill and lower the MG-220 Magnetic Gradiometer's sensor into the borehole.

Any steel drum located in the borehole's path (within 4 feet) will cause the MG-220's audio "alert" signal to increase in frequency as the sensor nears the bottom of the borehole. The MG-220 also provides a digital readout of the intensity and the polarity of the drum's magnetic field.

This battery powered, portable magnetic gradiometer detects, measures, and indicates the polarity of the magnetic field of any ferromagnetic object. It consists of a built-in electronics module and a 25-ft cable/sensor assembly which stores inside the carrying case.

Call 1-800-999-8280 for the dealer nearest to you, or to get your free applications brochure.



**MG-220  
Audio Signal**

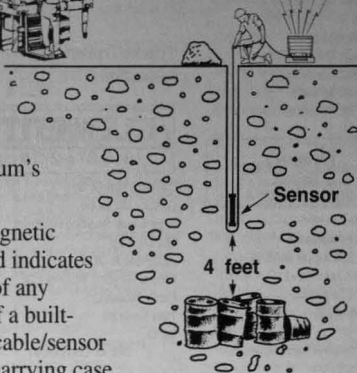

MG-220 Magnetic Gradiometer

**DEALER  
INQUIRIES  
WELCOME**

**Circle 85 on card.**

**S**  
**SCHONSTEDT INSTRUMENT COMPANY**

1775 Wiehle Avenue, Reston, VA 22090-5199 USA  
Phone (703) 471-1050 FAX (703) 471-1795

**Heath Consultants Inc**  
SEE AD ON PAGE 142  
Heritage Environmental Services Inc  
Hill International Inc  
J J Keller & Associates Inc  
JT Baker Chemical Inc  
John Crane Inc  
Mabbett & Associates Inc  
Marine & Environmental Testing Inc  
Marshall Industrial Technologies  
NST Engineers  
Nateco

SEE AD ON PAGE #  
New Environment Inc

**New Pig Corp**  
SEE AD ON PAGE 138

North Carolina State University  
Environmental Programs  
Occupational Health & Hygiene  
Corp of America  
Ogden Environmental & Energy Services  
Oxford Environmental Inc  
Perkin-Elmer Corp  
Primatich Inc  
Professional Analytical & Consulting  
Services Inc  
R E Wright Associates Inc (REW)  
SRI Instruments



**1-800-323-5040**  
Safety-Kleen

Safety Kleen Corp  
Sunshine Technology Corp  
Superior Environmental Corp  
Terra Bio Chem Environmental &  
Engineering Services Inc  
Texas Engineering Extension Service  
Transport Law Research Inc  
Trinity Consultants Inc  
U C Berkeley Extension-  
Environmental Mgmt  
University of Florida TREEO Center  
Waid & Associates



**800-324-2744**  
Williams Knowledge Systems

**Williams Knowledge Systems Inc**  
SEE AD ON PAGE 9

**Training Videos**

BNA Communications Inc  
Cole-Parmer Instrument Co  
Con-Test  
ELB & Associates  
ERM Group, The  
Eastern Technical Associates  
Emergency Film Group  
Environmental Resource Center



**800-227-4224**  
HACH

Hach Co  
**Heath Consultants Inc**  
SEE AD ON PAGE 142

J J Keller & Associates Inc  
JT Baker Chemical Inc  
Lab Safety Supply  
Labelmaster  
Marshall Industrial Technologies  
NUS Training Corp  
National Marker Co  
**New Pig Corp**

SEE AD ON PAGE 138

North Carolina State University  
Environmental Programs  
R E Wright Associates Inc (REW)  
Restek Corp  
Signmark Div/Brady USA Inc  
Spectronics Corp  
Summit Training Source

University of Florida TREEO Center  
Valley Videos

**Transmitters**

Acromag Inc  
Bailey Controls Co  
Bailey-Fischer & Porter Co  
Bristol Babcock Inc  
Climatronics Corp



**303-530-9600**  
Dieterich Standard

**Dieterich Standard, a Dover Industries Co**  
SEE AD ON PAGE 64

Dwyer Instruments Inc  
Extech Instruments  
Gems Sensors Div  
George Fischer Inc  
Invalco Inc  
**Milltronics Inc**

SEE AD ON PAGE 16

Newport Electronics Inc  
NovaLynx Corp  
**Omega Engineering Inc**

SEE AD ON PAGE 2

Pace Transducer/CJ Enterprise  
Simpson Electric Co  
Thornton Associates Inc

**Transportation**

ATI  
Creative Errands Environmental  
Technologies  
Sample Transporter  
Cushman Inc  
Environmental Products & Services Inc  
Ferrick Construction Co Inc



**800-227-4224**  
HACH

Hach Co  
Heritage Environmental Services Inc  
Peoria Disposal Co  
Rollins Environmental  
Sewall, James W Co  
Soltac Corp  
Trans-Enviro Inc  
Transport Law Research Inc

**Traps**

Beko Condensate Systems Corp  
J + W Scientific

**Trucks/Trailers**

American Rolloff



**318-377-2776**  
CLEMENT

Clement Industries Inc  
Converto Mfg Co Inc  
Eager Beaver Recycling Equipment  
East Mfg Corp  
Maxi Products Co Inc  
National Recycling Equipment Co  
Peoria Disposal Co  
Trans-Enviro Inc  
**Vertek**

SEE AD ON PAGE 61

**Turbidity Instrumentation**

Ametek Inc  
Automation Products Inc  
Bailey Controls Co  
Ben Meadows  
Capital Controls Co Inc  
Coastal Leasing Inc  
Cole-Parmer Instrument Co

**Diversified Well Products Inc**  
SEE AD ON PAGE 30

H F Scientific Inc  
Hazzo Services Inc  
**HydroLab Corp**

SEE AD ON PAGE 22

Instrumental International  
Invalco Inc  
LINC Quantum Analytics  
Neotronics

**Omega Engineering Inc**  
SEE AD ON PAGE 2

Orbeco Analytical Systems Inc  
Perstorp Analytical Inc  
Schneider Instrument Co  
Solomat  
YSI Inc

**Turbidity Standards**

AE Environmental Services Inc  
Ben Meadows  
Environmental Resource Associates  
H F Scientific Inc



**800-227-4224**  
HACH

Hach Co  
Orbeco Analytical Systems Inc  
Solomat

**Ultrafiltration Equipment**

APV Heat Transfer/Separation  
Technologies  
Allied-Signal Inc Filtration Systems  
American Environmental International Inc  
Baler Equipment Co



**619-746-4995**  
DESAL

**Desalination Systems Inc**  
SEE AD ON PAGE 163

Dow Chemical Co, The  
Environmental Recovery Resources Inc  
Hyde Products Inc  
Ionics Inc  
Kornline Sanderson  
MAC Environmental A Div of MAC  
Equipment Inc  
**Osmonics Inc**

SEE AD ON PAGE 31

RGF Environmental Systems Inc  
Remco Engineering  
Sharples, Business Unit of Alfa Laval  
Separation  
Smith & Loveless Inc  
Spectrum Medical Industries  
Treatment Technologies  
United States Filter Corp  
Universal Process Equipment Inc  
Western Filter Co  
Wheelabrator Environmental  
Systems Inc  
Zimpro Environmental Inc

**Underground Storage Tank Equipment**

ARD Environmental Inc  
ATI  
Air Plastics Inc  
Alton Geoscience  
American EnviroSpect Inc  
Bixby International Corp  
Brown Minneapolis Tank  
Enco EMC Fiberglass Casing & Well  
Screens  
Environmental Products & Services Inc  
Fluidyne Corp  
**Foxboro Co, The**

SEE AD ON PAGE 46

**Heath Consultants Inc**  
SEE AD ON PAGE 142

Heritage Environmental Services Inc  
Highland Tank  
Inventron Inc  
Kinane Engineering  
Lab Safety Supply  
OPW Fueling Components  
R E Wright Associates Inc (REW)  
Smith & Loveless Inc  
Steel Tank Association  
Terra Bio Chem Environmental &  
Engineering Services Inc  
Total Containment Inc  
Veeder-Root Co

**Underground Tank Leak Monitors**

AE Environmental Services Inc  
AIM Safety USA Inc  
Agar Corp  
American EnviroSpect Inc  
Ariel Industries Inc  
Arizona Instrument Corp



**1-800-635-7330**  
AMS

**Art's Manufacturing & Supply (AMS)**  
SEE AD ON PAGE 53

Atlantic Screen & Mfg Inc  
BEM Systems Inc  
Ben Meadows  
Brown Minneapolis Tank  
Cosmos Gas Detection  
Direct Safety Co  
EBW Inc  
ELE International Inc/Solitest  
Products Div  
ERM Group, The  
Enco EMC Fiberglass Casing &  
Well Screens  
Environmental Products & Services Inc  
Ferrick Construction Co Inc  
Fluid Components Intl  
**Foxboro Co, The**

SEE AD ON PAGE 46



**510-745-1275**  
GASTECH

Gas Tech Inc  
Gems Sensors Div  
Grace Industries Inc  
Hazzo Services Inc

**Heath Consultants Inc**  
SEE AD ON PAGE 142

Hersey & Measurement  
Highland Tank  
Intek Corp/Rent-Alyzer  
LINC Quantum Analytics  
Lindmark Engineering Inc  
Monarch Instrument  
OPW Fueling Components  
**Photovac Monitoring Instruments**

SEE AD ON PAGE 42

Recon Environmental  
Rust Environment & Infrastructure  
Rust International Inc  
Terra Bio Chem Environmental &  
Engineering Services Inc  
Thermo Environmental Instruments



**1-800-394-9929**  
Tracer Research Corporation

Tracer Research Corp  
Universal Sensors & Devices Inc  
Veeder-Root Co

**Valuum Cleaning Equipment**

ARD Environmental Inc  
Abar Ipsen Industries  
Advance Machine Co  
Baler Equipment Co  
DeMarco MAX VAC Corp  
Environmental Products & Services Inc  
Fisher Scientific Safety Products Div  
Goodway Technologies Corp  
Hazzo Services Inc  
Hi Vac Corp  
Hild Floor Machine  
Lamson Corp  
Minuteman Intl Inc  
Mole Master Services Corp  
Nilisk of America Inc  
NorTech Corp  
Pentek Inc  
Terra Universal  
Vac-U-Max  
Vacuum Engineering  
Vector Technologies Ltd

**Vacuum Loading Equipment**

Accurate Industries  
Baker Tanks  
Carbon Service & Equipment Co  
DeMarco MAX VAC Corp  
Environmental Products & Services Inc  
Guzzler Mfg Inc  
Hi Vac Corp  
Vac-U-Max  
Vacuum Engineering  
Vector Technologies Ltd

**Vacuum, Critical Filtration**

Critical-Vac Filtration Corp (CVAC)  
DeMarco MAX VAC Corp  
Fisher Scientific Safety Products Div  
Hild Floor Machine  
Minuteman Intl Inc  
Nilisk of America Inc  
Vacuum Engineering  
Vector Technologies Ltd

**Valve Actuators/Operators**

Asahi/America Inc  
Chemtrol Div of Nibco Inc  
Clarkson Co, The  
Durricon Co Inc, The  
Dwyer Instruments Inc  
General Rubber Corp/Flexible Valve Corp  
George Fischer Inc  
Hamilton Co  
Limitrque



**1-800-642-2699**  
NIBCO

Nibco Inc  
**Omega Engineering Inc**  
SEE AD ON PAGE 2

**Parker Hannifin Corp**  
SEE AD ON PAGE 144

Progressive Equipment Corp  
Rotork Controls Inc  
Swagelok Companies, The

**Valve Positioners**

Durricon Co Inc, The  
Dwyer Instruments Inc  
Foppe Thelen Group Inc  
General Rubber Corp/Flexible Valve Corp  
George Fischer Inc  
Hamilton Co  
Limitrque  
**Parker Hannifin Corp**  
SEE AD ON PAGE 144  
Surface Combustion Inc

**Valve Replacement Parts**

Automatic Switch Co (ASCO)  
Chemtrol Div of Nibco Inc  
Clarkson Co, The  
General Rubber Corp/Flexible Valve Corp  
Hamilton Co  
Robbins & Myers Inc/Moyno Industrial Products Div  
Xomox Corp

**Valve Systems**

Automatic Switch Co (ASCO)  
Durrinco Co Inc, The  
Dwyer Instruments Inc  
Environmental Monitor Systems Inc  
Hamilton Co  
Hazzo Services Inc  
I.L.C. Dover Inc  
MKS Instruments Inc  
**Parker Hannifin Corp**  
SEE AD ON PAGE 144  
Perkin-Elmer Corp  
Swagelok Companies, The  
Valve Technology Co

**Valves**

Air Plastics Inc  
Asahi/America Inc  
Ashbrook Corp  
Atomkatic Valve Co Inc  
Automatic Switch Co (ASCO)  
Breslow Separator Co Inc  
Chemtrol Div of Nibco Inc  
Civacon-Dover Resources  
Clarkson Co, The



**516-467-1600**

Clean Gas Systems Inc  
Cole-Parmer Instrument Co  
Durrinco Co Inc, The  
Dwyer Instruments Inc  
Energy Hydraulics  
Flomatic Corp  
Fluoroware  
Forrer Supply Co Inc  
General Rubber Corp



**800-233-6294**

General Rubber Corp/Flexible Valve Corp  
George Fischer Inc  
Griswold Controls  
Hamilton Co  
Invalco Inc  
J + W Scientific  
Jerman Waterworks Supply  
Justrite Mfg Co/Div of Federal Signal Corp  
Larox Inc  
MKS Instruments Inc



**1-800-645-7339**

**MMC Int'l Corp**  
SEE AD ON PAGE 23  
Midwestco Filter Resources Inc



**1-800-642-2699**

Nibco Inc  
OPW Fueling Components  
**Omega Engineering Inc**  
SEE AD ON PAGE 2  
**Osmonics Inc**  
SEE AD ON PAGE 31  
Pacer Pumps Div, ASM Industries Inc

**Parker Hannifin Corp**  
SEE AD ON PAGE 144

Plastic Fusion Fabricators  
Robbins & Myers Inc/Moyno Industrial Products Div  
Specialty Mfg Co, The  
Spraying Systems Co  
Swagelok Companies, The  
Valve Technology Co  
Xomox Corp

**Vapor Recovery**

ABB Environmental Services Inc  
AGA Gas Inc  
Airex Div Adwest Technologies  
Alliance Environmental Inc  
American Environmental International Inc  
Anguil Environmental Systems Inc  
**Art's Manufacturing & Supply (AMS)**  
SEE AD ON PAGE 53

Atlantic Screen & Mfg Inc  
BEM Systems Inc  
Blasland Bouck & Lee Inc  
CET Environmental Services Inc  
Calgon Carbon Corp  
Carbon Activated  
Civacon-Dover Resources  
Decoo Inc  
**Diversified Well Products Inc**  
SEE AD ON PAGE 30  
Dow Chemical Co, The  
Ducon Environmental Systems Inc



**313-459-6800**

Durr Industries Inc  
EPG Companies Inc  
Edwards Engineering  
Environision Group Inc, The  
GeoPure Continental Systems & Services  
Horizontal Technologies Inc  
Intervac  
Lamson Corp  
Liquid Carbonic  
Membrane Technology & Research Inc  
Monarch Separators Inc



**714-738-5000**

Morehouse-Cowles Inc  
Morrison, Knudsen Corp  
NAO Inc  
National Environmental Systems Inc  
**National Technical Systems Inc**  
SEE AD ON PAGE 17  
OPW Fueling Components  
ORS Environmental Systems  
Purus Inc  
R E Wright Associates Inc (REWI)  
Servomex Co Inc  
Superior Environmental Corp  
Thermotron  
Total Containment Inc  
Universal Process Equipment Inc  
Vera Intl Div of Calgon Carbon Corp  
Xchanger Inc  
Zink, John Co Div of Koch Engineering Co Inc

**Variable Speed Drives**

ANVIC Controls  
Boston Gear  
**Diversified Well Products Inc**  
SEE AD ON PAGE 30  
EBW Inc  
EPG Companies Inc  
G E Co  
Moran Manufacturing Inc  
Reliance Electric Co  
Sew Eurodrive

**Ventilation Equipment**

Air Plastics Inc  
Ben Meadows  
Duall Div Met-Pro Corp  
Hartzell Fan Inc  
Hazzo Services Inc  
Marshall Industrial Technologies  
Micro Air, Air Cleaners by Metal-Fab Inc  
New York Blower Co  
Stanley Consultants Inc  
United McGill Corp

**Vents**

EBW Inc  
Ferro Corp, Specialty Ceramics Div/Filtros Plant  
Filtros Plant, Ferro Corp  
Justrite Mfg Co/Div of Federal Signal Corp  
Midwestco Filter Resources Inc  
OPW Fueling Components

**Vibration Instruments**

Bruel & Kjaer Instruments  
Campbell Scientific Inc  
Epic Inc  
Monarch Instrument  
**Omega Engineering Inc**  
SEE AD ON PAGE 2  
Pace Transducer/CJ Enterprise  
Soltec Corp  
Terra Universal

**Viscosity Instruments**

Automation Products Inc  
Barnart Co  
ELE International Inc/Soiltest Products Div  
Extect Instruments  
Fisher Scientific Safety Products Div  
Fluid Data Inc  
Lab-Line Instruments Inc  
Neslab Instruments Inc  
Norcross Corp  
**Omega Engineering Inc**  
SEE AD ON PAGE 2  
Petrolab Corp

**VOC Removal Systems**

**ABB Air Preheater Inc**  
SEE AD ON PAGE 141  
ABB Raymond  
APV Heat Transfer/Separation Technologies  
AWD Technologies Inc  
Activated Carbon Resources  
**Adwest Technologies Inc**  
SEE AD ON PAGE 36  
Aeromix Systems Inc  
Airex Div Adwest Technologies



**918-266-1400**

Allied-Signal Inc Environmental Catalysts  
Alton Geoscience  
Ambient Engineering Inc  
American Environmental International Inc  
American Gas Products Inc  
Anguil Environmental Systems Inc  
Barneby & Sutcliffe Corp  
Beltran Associates Inc  
BioTrol Inc



**(602) 624-4644**

Bohn Biofilter Corp  
Brown & Root Environmental  
Burns & McDonnell  
CET Environmental Services Inc  
CSM Environmental Systems Inc

CVM Corp  
Calgon Carbon Corp  
Carbon Activated  
Carbonair Environmental Systems  
Carbtrol Corp  
College Research Corp (CORECO)  
**Commercial Dexterity Ltd**  
SEE AD ON PAGE 64  
**Delta Cooling Towers Inc**  
SEE AD ON PAGE 62  
Diagraph Corp  
Duall Div Met-Pro Corp  
Ducon Environmental Systems Inc



**313-459-6800**

Durr Industries Inc  
EA Engineering, Science & Technology Inc  
ENSCI Environmental Inc  
EPG Companies Inc  
Engelhard Corp  
Envirex  
Envirogen Inc  
Environmental Recovery Resources Inc  
**Environmental Restoration Systems Inc**  
SEE AD ON PAGE 18

Falmouth Products  
Feco Engineered Systems Inc  
Fluidyne Corp  
Foster Wheeler Environmental Corp  
General Carbon Corp  
GeoPure Continental Systems & Services  
Grace TEC Systems  
H2 Oil Recovery Equipment Inc  
Hazleton Environmental  
Hydro Group  
JBI Spray Booth Systems  
Jaeger Products Inc



**Johnson Matthey**  
**610-971-3100**

Johnson Matthey Env  
Kinane Engineering  
Lamson Corp  
Landa Inc  
Lindmark Engineering Inc  
MMT Environmental Services Inc  
Membrane Technology & Research Inc  
**Met-Pro Corp Systems Div**  
SEE AD ON PAGE 43  
Misonix Inc



**314-275-5700**

Monsanto Enviro-Chem  
Morrison, Knudsen Corp  
NAO Inc  
National Environmental Systems Inc  
North East Environmental Products Inc  
Northwestern Carbon  
Norton Chemical Process Products Corp  
O'Brien & Gere Technical Services Inc  
ORS Environmental Systems  
R E Wright Associates Inc (REWI)  
Ross Air Systems  
**Salem Enghard**  
SEE AD ON PAGE 119  
Superior Environmental Corp



**Surface Combustion**  
**1-800-537-8980**

Surface Combustion Inc  
Tallkamp Systems Inc  
Thermotron  
Tri-Mer Corp  
Turner EnviroLogic Inc



**713-943-3753**

Unisorb Corp  
United McGill Corp  
United States Filter Corp  
Universal Process Equipment Inc  
Vera Intl Div of Calgon Carbon Corp  
W R Grace - Grace Emission Control  
Wheelerator Environmental Systems Inc  
Winsor & Jerault  
Wolverine (Massachusetts) Corp  
Xchanger Inc  
Zink, John Co Div of Koch Engineering Co Inc

**Waste Energy**

Leslie Mfg Inc

**Waste Minimization**

A M R C Inc (AIHMM)  
AIG Consultants Inc  
ATEC Associates Inc  
Admiral Environmental Services Inc  
Alliance Environmental Inc  
Alton Geoscience  
Arthur D Little Inc  
BEM Systems Inc  
Blasland Bouck & Lee Inc  
Brown & Root Environmental  
Center for Hazardous Materials Research  
ChemCycle Corp  
College Research Corp (CORECO)  
Compacting Technologies



**1-800-844-1400**

**Computer All**  
SEE AD ON PAGE 120

Consulting Environmental Engineering Inc  
Dames & Moore  
Decoo Inc  
Detail Associates Inc  
Diagraph Corp  
EA Engineering, Science & Technology Inc  
EET Inc  
ENSCI Environmental Inc  
ERM Group, The  
**Eco Waste Solutions**  
SEE AD ON PAGE 55  
Enviro Filtration  
Enviro-Sciences Inc  
Environgen Inc  
Environmental Compaction Inc  
Environmental Products & Services Inc



**714-975-6480**

Fluor Daniel Environmental Services Inc  
Foster Wheeler Environmental Corp  
Foth & Van Dyke  
G A Huber Co  
Graef Anhalt Schloemer  
H H Burkitt Project Management Inc  
Hart Crowser Inc  
Heritage Environmental Services Inc  
Hyde Products Inc  
International Technology Corp  
J V Mfg Inc/Cram-A-Lot



**1-800-214-1682**

JWI  
Jaca Corp  
Kennedy/Jenks Consultants

# WATER POLLUTION CONTROL NEWS



In an overwhelming vote of 95-3, the Senate resolves key environmental issues under newly reauthorized SDWA.

"Something's changed on Capitol Hill," Rafe Pomerance at the Department of State, said. "... there has been a shift in the public mood and a shift in the political mood."

Rep. Norman Mineta is forced to reconsider his refusal to hold house hearings on HR 3948.

# FROM THE INSIDE OUT

## 'HOSTILE' MOOD PERVADES CONGRESS, PUBLIC WHEN IT COMES TO ENVIRONMENTAL REGULATION

Opposition to environmental legislation is not limited to big industry anymore. Mike Evans, Senate Staffer said, "the regulated communities today are farmers, state and local government and people generally. Your enemy today, in many ways, is not the National Association of Manufacturers, it's the National Governors Association."

## SENATE RESOLVES RISK ASSESSMENT UNDER NEWLY REAUTHORIZED SDWA

Capitol Hill watchers fear amendments might hold up or complicate matters after the House passes an SDWA bill and the two versions must be reconciled.

## CONGRESSIONAL FIREWORKS APPEAR LIKELY IN HOUSE OVER COALITION'S NEW CWA BILL

On the same day, dissatisfied with Mineta's bill, a coalition of committee members from both parties, unveiled their alternative to HR 3948. Congressional fireworks appear likely.

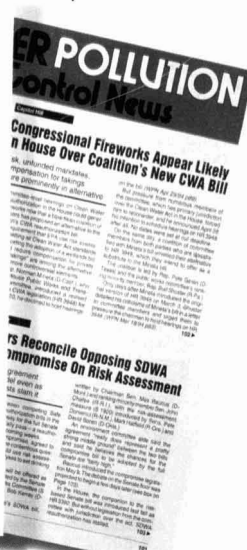

PUT OUR WATER POLLUTION CONTROL NEWS ON TRIAL WITH THIS MONEY BACK OFFER.

- In-depth, exhaustive news • legislation and regulation • fines and litigation • hot topics and critical concerns
- innovative proposals • easy-to-read charts • newsmaker interviews
- published twenty-four times a year

ORDER TODAY. CALL 800-207-3535

Circle 86 on card.

**STEVENS PUBLISHING**

Publisher of Environmental Protection

L Robert Kimball & Associates  
 Mabbett & Associates Inc  
**Mobile Process Technology**  
 SEE AD ON PAGE 48

Morrison, Krudsen Corp  
 Nalco Chemical Co  
 National Magnesia Chemicals  
**National Technical Systems Inc**  
 SEE AD ON PAGE 17

New Pig Corp  
 SEE AD ON PAGE 138

Normandeau Associates, RMC  
 Environmental Services Div  
 Ogen Environmental & Energy Services  
 Parsons Engineering Science Inc  
 Plainsol

R E Wright Associates Inc (REWI)  
 RMT Inc

Radian Corp  
 Raytheon Engineers &  
 Constructor/Raytheon Enviro Svcs  
 Recon Environmental  
 Remco Engineering  
 Research Products/Blankenship  
 Rust Environment & Infrastructure  
 Rust International Inc  
 SSM/Spotts Stevens & McCoy Inc  
 Serio-Us Lock  
 Sewall, James W Co  
 Soil & Material Engineers Inc  
 Superior Environmental Corp  
 Sverdrup Environmental Inc  
 Tedder & Widheim Consultants Inc  
 Trans-Enviro Inc  
 Traverse Group, The  
 Treatment Technologies  
 21 EMI/Elicam  
 United States Filter Corp  
 Universal Process Equipment Inc  
 Versar Inc  
 Wellington Environmental Consulting &  
 Construction Inc  
 Wheelabrator Engineered Systems Inc -  
 Memtek Products

**Wastewater Treatment Systems**

A O Smith Harvestore Products Inc  
 AAF International  
 AE Environmental Services Inc  
 AFL Industries Inc  
 AGA Gas Inc  
 APV Heat Transfer/Separation  
 Technologies  
 ARD Environmental Inc  
 AWD Technologies Inc  
 Aeromix Systems Inc  
 Air Plastics Inc  
 Alar Engineering Corp  
 Andco Environmental Processes Inc  
 Aqua-Chem Inc  
 AquaTec Inc  
 Atlantic Ultraviolet Corp  
 Baler Equipment Co  
 Beckart Environmental Inc

**BIO-SYSTEMS CORPORATION**  
 608-365-9550

Bio-Systems Corp  
 BioTrol Inc  
 Bioscience Inc  
 Blasiand Bouck & Lee Inc  
 Bran & Luebbe Inc  
 Bristol Babcock Inc  
 Brown & Root Environmental  
 Brown Minneapolis Tank  
 Burns & McDonnell  
 Calgon Carbon Corp  
 Capital Controls Co Inc  
 Carbon Activated  
 Carbol Corp  
 Celite Corp  
 Chester Environmental  
 Chief Industries

Chlorinators Inc  
 College Research Corp (CORECO)  
 Colloid Environmental Technologies Co  
**Commercial Dexterity Ltd**  
 SEE AD ON PAGE 64

Consulting Environmental Engineers Inc  
 Dames & Moore  
 Deeco Inc  
**Delta Cooling Towers Inc**  
 SEE AD ON PAGE 62

Denver Mineral Engineers Inc

**DESAL**  
 DESALINATION SYSTEMS, INC.  
 619-746-4995

**Desalination Systems Inc**  
 SEE AD ON PAGE 163

Diagenex Inc  
 Discflo Corp  
**Diversified Well Products Inc**  
 SEE AD ON PAGE 30

Duriron Co Inc, The  
 EIMCO Process Equipment Co  
 ERM Group, The  
 Eckenfelder  
**Eco Waste Solutions**  
 SEE AD ON PAGE 55

**Ejector Systems Inc**  
 SEE AD ON PAGE 52

Envirex  
 Enviro-Sciences Inc  
 Environmental Protection Inc  
 Environmental Recovery Resources Inc

**EPOLEON CORPORATION OF AMERICA**  
 1-800-EPOLEON

**Epoleon Corp of America**  
 SEE AD ON PAGE 24

Flomatic Corp  
 Fluidyne Corp  
 Foster Wheeler Environmental Corp  
 Framco Environmental Technologies  
 Frontier Technology Inc  
 G E Co  
 General Carbon Corp  
**Geo-Con Inc**  
 SEE AD ON PAGE 54

Global Water  
 Graef Anhalt Schloemer  
 Great Lakes Environmental Inc  
 Green Earth Technologies Corp  
 Harklin Environmental Systems Inc  
 Harborlite Corp  
 Hazleton Environmental  
 Hightage Environmental Services Inc  
 Highland Tank  
 Hitachi Maxco Ltd  
 Hycor Corp  
 Hyde Products Inc  
 Industrial Filter & Pump Mfg Co  
 Inn-Nova-Tech Inc  
 Intec Controls Corp  
 International Technology Corp  
 Ionics Inc

**JMI**  
 1-800-214-1682

JWI  
 Jet Inc  
 Kinane Engineering  
 Komline Sanderson  
 Lamson Corp  
 Landa Inc  
 Mabbett & Associates Inc  
 Marshall Industrial Technologies

**Martin Marietta Magnesia Specialties**  
 1-800-648-7400

Martin Marietta Magnesia Specialties Inc

**Met-Pro Corp Systems Div**  
 SEE AD ON PAGE 43

**Mobile Process Technology**  
 SEE AD ON PAGE 48

Monarch Separators Inc  
 NST Engineers  
 Nalco Chemical Co  
 National Magnesia Chemicals  
 Nautus Inc  
 Nirol Inc  
 SEE AD ON PAGE 51

O'Brien & Gere Technical Services Inc  
 Oil Skimmers Inc  
**Omega Engineering Inc**  
 SEE AD ON PAGE 2

Osmonics Inc  
 SEE AD ON PAGE 31

**OSMONICS INTERNATIONAL CORP**  
 415-952-9904

Ozonair Intl Corp  
 Ozone Research & Equipment Corp An  
 Parkson Corp  
 Parsons Engineering Science Inc  
 Peroxidation Services Inc  
 Pollution Control Inc  
 Polybac Corp  
 ProMinent Fluid Controls Inc  
 Progressive Equipment Corp  
 Purestream Inc  
 R E Wright Associates Inc (REWI)  
 RMT Inc  
 Raytheon Engineers &  
 Constructor/Raytheon Enviro Svcs  
 Recon Environmental  
 Reliance Electric Co  
 Remco Engineering  
 Research Products/Blankenship  
 Resource Consultants Inc  
 Resources Conservation Co  
 Rust Environment & Infrastructure  
 SSM/Spotts Stevens & McCoy Inc  
 Sewall, James W Co  
 Sharples, Business Unit of Alfa Laval  
 Separation  
 Sixnet  
 Smith & Loveless Inc  
 Solox A Division of Solar Kinetics Inc  
 Spectraserv  
 Star Systems Filtration Division/Hilliard  
 of SC Inc  
 Suburbia Systems Corp  
 Sverdrup Environmental Inc

**SWENSON**  
 708-331-5500

Swenson Process Equipment Inc  
 Sybron Chemicals Inc  
 Technotreat Corp  
 Tenco Hydro Inc  
 3M Filtration Products  
 Traverse Group, The  
 Treatment Technologies  
 US Filter Corp  
**Unipure Environmental**  
 SEE AD ON PAGE 10

United States Filter Corp  
 Universal Process Equipment Inc  
 Vac-U-Max  
 Vaughn Co Inc  
 Vibra Screw Inc  
**Wallace & Tierman Inc**  
 SEE AD ON PAGE 29

Waste Stream Technology Inc  
 Water Equipment Tech  
 Water Inc  
 Wheelabrator Clean Water Systems  
 Inc/Bio Gro Div  
 Wheelabrator Engineered Systems Inc -  
 Memtek Products  
 Wheelabrator Environmental  
 Systems Inc  
 Zimpro Environmental Inc

**Water Conditioning Equipment**

Atlantic Ultraviolet Corp  
 Capital Controls Co Inc  
**Delta Cooling Towers Inc**  
 SEE AD ON PAGE 62

Dow Chemical Co, The  
 Engelhard Corp  
 Environmental Protection Systems  
 Hitachi Maxco Ltd  
 Hydro Group  
 Industrial Filter & Pump Mfg Co  
 Lyco Manufacturing Inc  
**Osmonics Inc**  
 SEE AD ON PAGE 31

Ozone Research & Equipment Corp An  
 Remco Engineering  
 Taylor Technologies  
 Treatment Technologies  
 United States Filter Corp  
 Vac-U-Max  
 Western Filter Co  
 Wheelabrator Environmental  
 Systems Inc

**Water Jetting Equipment**

Green Earth Technologies Corp  
 Hazleton Environmental  
 Price-Darnall Inc of Alabama  
 Schreiber Corp Inc  
 Spartan Mfg Corp

**Water Meters**

**Badger Meter Inc**  
 SEE AD ON PAGE 4

Ben Meadows  
 Data Industrial Corp  
**Diversified Well Products Inc**  
 SEE AD ON PAGE 30

ELE International Inc/Soltest  
 Products Div  
 EPG Companies Inc  
 George Fischer Inc  
 Global Water  
 Handar  
 Hazzo Services Inc  
 Hershey & Measurement  
 Hershey Products  
 ISTA Energy Systems Corp  
 Instruments Direct Inc  
 Jerman Waterworks Supply  
 NovaLynx Corp  
**Omega Engineering Inc**  
 SEE AD ON PAGE 2

Sparing Instruments Co Inc

**Water Purification Systems**

Aqua-Chem Inc  
 Atlantic Ultraviolet Corp  
 Baler Equipment Co  
 Beckart Environmental Inc  
 Biomin Inc  
 Burns & McDonnell  
 CHEMetrics Inc  
 Capital Controls Co Inc  
 Carbol Corp  
 Celite Corp  
 Chester Environmental  
 Chlorinators Inc  
**Delta Cooling Towers Inc**  
 SEE AD ON PAGE 62

**DESAL**  
 DESALINATION SYSTEMS, INC.  
 619-746-4995

**Desalination Systems Inc**  
 SEE AD ON PAGE 163

Engelhard Corp  
 Equinox International  
 General Carbon Corp  
 Global Water  
 Green Earth Technologies Corp

H2 Oil Recovery Equipment Inc  
 Harborlite Corp  
 Hazleton Environmental  
 Industrial Filter & Pump Mfg Co  
 Ionics Inc  
**Mobile Process Technology**  
 SEE AD ON PAGE 48

Norit Americas Inc  
**Osmonics Inc**  
 SEE AD ON PAGE 31

**OSMONICS INTERNATIONAL CORP**  
 415-952-9904

Ozonair Intl Corp  
 Ozone Research & Equipment Corp An  
 Peroxidation Services Inc  
 ProMinent Fluid Controls Inc  
 Progressive Equipment Corp  
 Remco Engineering  
 SSM/Spotts Stevens & McCoy Inc  
 Sharples, Business Unit of Alfa Laval  
 Separation  
 Smith & Loveless Inc  
 Solox A Division of Solar Kinetics Inc  
 Spectraserv  
 Spectrum Medical Industries  
 Sverdrup Environmental  
 3M Filtration Products  
 United States Filter Corp  
 Water Equipment Tech  
 Western Filter Co  
 Wheaton Science Products  
 Wheelabrator Engineered Systems Inc -  
 Memtek Products  
 Wheelabrator Environmental  
 Systems Inc  
 Wilkens-Anderson Co

**Water Quality Instrumentation**

ATI Orion  
 American Scientific Instrumentation  
 Anatel Corp

**BVS 610-273-2841**

BVS Inc  
 Bailey Controls Co  
 Ben Meadows  
 Campbell Scientific Inc  
 Capital Controls Co Inc  
 Cole-Parmer Instrument Co  
**Colog Inc**  
 SEE AD ON PAGE 32

**Diversified Well Products Inc**  
 SEE AD ON PAGE 30

E S Industries  
 EIT  
 ELE International Inc/Soltest  
 Products Div  
 Engelhard Corp  
 Envirex  
 Finnigan/Tremetics  
 G O Environment Inc  
 H F Scientific Inc

**HACH**  
 800-227-4224

Hach Co  
 Handar  
 Hazzo Services Inc  
**Horiba Instruments Inc**  
 SEE AD ON PAGE 44

**HydroLab Corp**  
 SEE AD ON PAGE 22

Innovative Sensors Inc  
 Intek Corp/Rent-Alyzer  
 Isco Inc Environmental Div  
 Keoco R & D Inc  
 LINC Quantum Analytics

**Milco Safety Rental**  
SEE AD ON PAGE 64



**Mount Sopris Instrument Co**  
SEE AD ON PAGE 35

Myron L Co  
Neotronics  
NovaLynx Corp  
OI Analytical  
Orbeco Analytical Systems Inc  
Perkin-Elmer Corp  
Progressive Equipment Corp  
Remco Engineering  
Response Rentals  
Rosemount Analytical  
SWAN/Industries Analytics  
Schneider Instrument Co  
Sensidyne Inc  
Sensorex  
Sievers Instruments Inc  
Sixnet  
Solomat  
Taylor Technologies  
Thornton Associates Inc  
Turner Designs  
Unidata America  
Vitel Inc  
Wilkens-Anderson Co  
YSI Inc

**Water/Wastewater Treatment Equipment**

AFL Industries Inc  
AFL Industries Inc  
APV Heat Transfer/Separation Technologies  
Aeromix Systems Inc  
Air Plastics Inc  
AirSep Corp  
Alar Engineering Corp  
American Lewa Inc



Ameron  
Andco Environmental Processes Inc  
AquaTec Inc  
Atlantic Ultraviolet Corp  
Bailey-Fischer & Porter Co  
Baker Tanks  
Baler Equipment Co  
Beckart Environmental Inc  
Bird Machine Co Inc  
BioTrol Inc  
Bioscience Inc  
Bran & Luebbe Inc  
Brown Minneapolis Tank  
CHEMetrics Inc  
Calgon Carbon Corp  
Capital Controls Co Inc  
Carbon Service & Equipment Co  
Carbrol Corp  
Celite Corp  
Chem-Pruf Door Co  
Chemical Lime Co  
Cheminer Inc  
Chief Industries  
Chlorinators Inc  
Colloid Environmental Technologies Co



Columbian Steel Tank

Dancer Communications Inc  
**Delta Cooling Towers Inc**  
SEE AD ON PAGE 62

Denver Mineral Engineers Inc



**Desalination Systems Inc**  
SEE AD ON PAGE 163

Diagenex Inc  
Dow Chemical Co, The  
Duriron Co Inc, The  
EIMCO Process Equipment Co

**Ejector Systems Inc**  
SEE AD ON PAGE 52

Envirex  
Envirogen Inc  
Environmental Protection Systems  
Environmental Recovery Resources Inc  
**Environmental Restoration Systems Inc**  
SEE AD ON PAGE 18

FMI - Fluid Metering Inc  
Ferro Corp, Specialty Ceramics Div/Filtron Plant  
Filtros Plant, Ferro Corp  
Flomatic Corp  
Fluidyde Corp  
Frontier Technology Inc  
General Carbon Corp  
Global Water



Gorman-Rupp Co, The  
Great Lakes Environmental Inc  
H2 Oil Recovery Equipment Inc  
Hankin Environmental Systems Inc  
Harborlite Corp  
Hazco Services Inc  
Hazleton Environmental  
Highland Tank  
Hitachi Maxco Ltd  
Hudson Industries  
Hycor Corp  
Hyde Products Inc  
ILC Dover Inc  
Industrial Filter & Pump Mfg Co  
Inn-Nova-Tech Inc  
Innovative Sensors Inc  
Ionics Inc  
Isocon Environmental Div

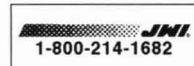

JWI  
Koch Engineering Co Inc  
Komline Sanderson  
Lakeside Equipment Corp  
Lamson Corp  
Landa Inc  
Liquid Carbonic  
**Liquid Waste Technology Inc**  
SEE AD ON PAGE 35

Luft Instruments Inc  
Lyco Manufacturing Inc  
MIOX Corp  
Marshall Industrial Technologies  
Martin Marietta Magnesia Specialties Inc  
Mastrrr Co, The  
McTighe Industries Inc  
**Met-Pro Corp Systems Div**  
SEE AD ON PAGE 43

**Mobile Process Technology**  
SEE AD ON PAGE 48

Monarch Separators Inc

Moran Manufacturing Inc  
National Environmental Systems Inc  
Nautus Inc  
North East Environmental Products Inc  
**Niro Inc**  
SEE AD ON PAGE 51

Oil Skimmers Inc  
**Osmonics Inc**  
SEE AD ON PAGE 31



Ozonair Intl Corp  
Ozone Research & Equipment Corp An  
Paco Pumps  
Parkson Corp  
Peroxidation Services Inc  
Phipps & Bird Inc  
Pollution Control Inc  
Power Plant Services  
ProMinent Fluid Controls Inc  
Progressive Equipment Corp  
Purus Inc  
QED GroundWater Specialists  
RGF Environmental Systems Inc  
Reliance Electric Co  
Remco Engineering  
Resources Conservation Co  
SRS Cristafulli Inc  
Schreiber Corp Inc  
Seneca Environmental Services Inc  
Sensorex  
Serflico Ltd  
Sharples, Business Unit of Alfa Laval Separation  
Sixnet  
Smith & Loveless Inc  
Solox A Division of Solar Kinetics Inc  
Sparing Instruments Co Inc  
Spectraserv  
Spectronics Corp  
Stokes Vacuum Inc  
Suburbia Systems Corp  
Superior Environmental Corp



Swenson Process Equipment Inc  
Taylor Technologies  
Tenax Corp  
Traverse Group, The  
Treatment Technologies  
**Unipure Environmental**  
SEE AD ON PAGE 10

United States Filter Corp  
United States Filter Corp  
Universal Process Equipment Inc  
Vac-U-Max  
**Wallace & Tierman Inc**  
SEE AD ON PAGE 29

Warren Rupp Inc A Unit of IDEX  
Water Equipment Tech  
Water Inc  
Wheelabrator Engineered Systems Inc -  
Mentek Products  
Wheelabrator Environmental Systems Inc  
Zimpro Environmental Inc

**Water/Wastewater Treatment Plants**

A O Smith Harvestore Products Inc  
AE Environmental Services Inc  
AWD Technologies Inc  
Andco Environmental Processes Inc  
Aqua-Chem Inc  
AquaTec Inc

Bioscience Inc  
Chester Environmental  
Chief Industries  
Coastal Environmental Systems  
Colloid Environmental Technologies Co  
Denver Mineral Engineers Inc  
Envirex  
FBA Environmental Inc  
Fluidyne Corp

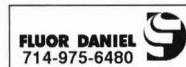

Fluor Daniel Environmental Services Inc  
Foster Wheeler Environmental Corp  
Foth & Van Dyke  
Global Water  
Graef Anhalt Schloemer  
Hart Crowser Inc  
Hazen & Sawyer  
Hazleton Environmental  
Heritage Environmental Services Inc  
Hitachi Maxco Ltd  
Inn-Nova-Tech Inc  
Ionics Inc  
Marshall Industrial Technologies  
**Met-Pro Corp Systems Div**  
SEE AD ON PAGE 43

Monarch Separators Inc  
Northwestern Carbon  
O'Brien & Gere Technical Services Inc  
Ogden Environmental & Energy Services



Ozonair Intl Corp  
Parkson Corp  
Parsons Engineering Science Inc  
Pollution Control Inc  
Poly-Flex Inc  
R E Wright Associates Inc (REWI)  
Raytheon Engineers & Constructor/Raytheon Enviro Svc  
Recon Environmental  
Remco Engineering  
Resources Conservation Co  
Rust Environment & Infrastructure  
Rust International Inc  
SSM/Spotts Stevens & McCoy Inc  
Schreiber Corp Inc  
Sevenson Environmental Services Inc  
Sewall, James W Co  
Smith & Loveless Inc  
Spartan Mfg Corp  
Spectraserv  
Stanley Consultants Inc  
Stearns & Wheeler  
Suburbia Systems Corp  
Sverdrup Environmental Inc  
Treatment Technologies  
21 EMI/Elicam  
United States Filter Corp  
Water Inc  
Western Filter Co  
Wheelabrator Environmental Systems Inc  
Zimpro Environmental Inc

**Weather Monitoring**

Aanderaa Instruments Inc  
Advanced Control Systems  
Air Science Consultants  
Ben Meadows  
Brooklyn Thermometer Co Inc  
Campbell Scientific Inc  
Climatronics Corp  
Coastal Environmental Systems  
Coastal Leasing Inc

Cole-Parmer Instrument Co  
ELE International Inc/  
Soiltest Products Div  
Earth & Atmospheric Sciences Inc  
Galsion Corp  
Global Water  
Handar  
**Met-One Instruments Inc**  
SEE AD ON PAGE 26

Monarch Instrument  
NovaLynx Corp  
**Omega Engineering Inc**  
SEE AD ON PAGE 2

Raytheon Engineers & Constructor/Raytheon Enviro Svc  
Solomat  
Sonoma Technology Inc  
Stanley Consultants Inc  
Unidata America  
Vaisala Inc  
Versar Inc  
Vitel Inc  
Weather Metrics Inc

**Wetlands**

ABB Environmental Services Inc  
ACRT Inc Environmental Specialist  
AWD Technologies Inc  
Adirondack Environmental Associates Inc  
Applied Science & Technology Inc  
BEM Systems Inc  
Barr Engineering Co  
Ben Meadows  
Bock Environmental Service Inc  
Braun Intertec Corp  
Brown & Root Environmental  
Burns & McDonnell  
Chester Environmental  
Commonwealth Biomonitoring Corporation for Environmental Management  
Dames & Moore  
EA Engineering, Science & Technology Inc  
ERM Group, The  
ERM-South Inc  
Foth & Van Dyke  
Geo-Technology Associates Inc  
Graef Anhalt Schloemer  
Hart Crowser Inc  
Hydro-Terra Inc  
L Robert Kimball & Associates  
Ogden Environmental & Energy Services  
Parsons Engineering Science Inc  
Professional Analytical & Consulting Services Inc  
R E Wright Associates Inc (REWI)  
RMT Inc  
Raytheon Engineers & Constructor/Raytheon Enviro Svc  
Recon Environmental  
Reef Industries Inc  
Rust Environment & Infrastructure  
Rust International Inc  
SSM/Spotts Stevens & McCoy Inc  
Soil & Material Engineers Inc  
Stanley Consultants Environmental Inc  
Stearns & Wheeler  
Superior Environmental Corp  
Traverse Group, The  
Walk, Haydel & Associates Inc  
Wellington Environmental Consulting & Construction Inc

# Company Profiles

This section of the *1995 Environmental Protection Buyer's Guide* gives an alphabetical listing of those companies that sell products and services in the environmental market. Each listing includes company name, address and phone number. *Buyer's Guide* advertisers and the pages on which their ads appear are listed in bold type.

## Company Profiles Alphabetical Listings Begin on the Following Pages:

<b>A</b> .....	<b>121</b>	<b>N</b> .....	<b>131</b>
<b>B</b> .....	<b>123</b>	<b>O</b> .....	<b>132</b>
<b>C</b> .....	<b>124</b>	<b>P</b> .....	<b>133</b>
<b>D</b> .....	<b>125</b>	<b>Q</b> .....	<b>133</b>
<b>E</b> .....	<b>125</b>	<b>R</b> .....	<b>134</b>
<b>F</b> .....	<b>127</b>	<b>S</b> .....	<b>134</b>
<b>G</b> .....	<b>127</b>	<b>T</b> .....	<b>135</b>
<b>H</b> .....	<b>128</b>	<b>U</b> .....	<b>136</b>
<b>I</b> .....	<b>129</b>	<b>V</b> .....	<b>136</b>
<b>J</b> .....	<b>130</b>	<b>W</b> .....	<b>136</b>
<b>K</b> .....	<b>130</b>	<b>X</b> .....	<b>137</b>
<b>L</b> .....	<b>130</b>	<b>Y</b> .....	<b>137</b>
<b>M</b> .....	<b>131</b>	<b>Z</b> .....	<b>137</b>

# 1995 Major Meetings Directory

**Editor's note: The meetings and conferences listed here will be held this year. The list was compiled in December 1994 from data supplied by the sponsors. Please call the phone numbers given for more information.**

## MARCH

PITTCON, March 5-10, New Orleans, La. Contact PITTCON at (412) 825-3220.

National Plant Engineering and Maintenance, March 13-17, Chicago, Ill. Contact Laurie Day at (203) 840-5328.

The Global Environmental Management Initiative (GEMI), March 22-23, Pentagon City, Arlington, Va. Contact Lisa Gray at (202) 429-0776.

Waste Combustion in Boilers and Industrial Furnaces Conference, March 28-30, Kansas City, Mo. Contact Registrar, Air & Waste Management Association, (412) 232-3445.

## APRIL

12th Annual HAZMACON Conference and Exposition, April 4-6, San Jose, Calif. Contact Terry Bursztynsky at (510) 464-7951.

GLOBALCON '95, April 19-20, San Francisco, Calif. Contact Alma McFarland at (404) 447-5083 ext. 224.

Environmental Management '95, April 22-26, Tampa, Fla. Contact Environmental Information Association at (404) 986-2760.

Bioreclamation Symposium, April 24-27, San Diego, Calif.

American Occupational Health Conference, April 29-May 5, Las Vegas, Nev. Contact (609) 848-1000.

## MAY

National Groundwater Association/Outdoor Action Conference and Exposition, May 2-4, Las Vegas, Nev. Contact (800) 551-7379.

BIO Ninth International Biotechnology Meeting & Exhibition, May 20-25, San Francisco, Calif. Contact BIO Meetings Department at (202) 857-0244.

American Industrial Hygiene Conference, May 20-26, Kansas City, Mo. Contact AIHA at (703) 849-8888.

Second Annual Environmental Marketing Conference and Exposition, May 22-24, Atlanta, Ga. Contact Diana Ludwig at (404) 988-9558.

First Thailand/U.S. Industrial Environmental Conference and Exposition, May 22-25, Bangkok, Thailand. Contact Jack Flynn at (619) 295-3461, or fax (619) 299-5268.

## JUNE

Hazmat International, June 14-16, Philadelphia, Pa. Attendees contact Petra Garrison at (708) 469-3373, ext. 147. Exhibitors contact Jeremy Bullas, (708) 469-3373 ext. 119.

American Water Works Association, June 18-22, Anaheim, Calif. Contact April DeBaker at (303) 794-7711.

Air and Waste Management Association, June 18-23, San Antonio, Texas. Contact Debbie Fair at (412) 232-3444.

ENVITEC 95, International Trade Fair for Environmental Protection and Waste Management Technologies, June 19-23,

Dusseldorf, Germany. Contact Dusseldorf Trade Shows Inc., (312) 781-5180 or fax (312) 781-5188.

American Society of Safety Engineers, June 19-24, Orlando, Fla. Contact American Society of Safety Engineers at (708) 692-4121 ext. 60.

Laboratory Safety & Environmental Management '95, June 26-29, Baltimore, Md. Contact Vicki Martin at (818) 842-4777.

## OCTOBER

Water Environment Federation, Oct. 21-25, Miami Beach, Fla. Contact (703) 684-2414 or (800) 666-0206.

National Groundwater, Oct. 28-30, Indianapolis, In. Contact Customer Service at (800) 551-7379.

## NOVEMBER

National Safety Council Congress and Expo, Nov. 5-10, Dallas, Texas. Contact Conference Planning Department at (708) 285-1121.

Hazardous Materials Control Institute's Superfund XVI Conference and Exhibition, Nov. 6-8, Washington D.C. Contact: Conference Department at (301) 251-1900.

Hazmat West, Nov. 7-9, Long Beach, Calif. Contact Petra Garrison at (708) 469-3373.

Environmental Technology Expo Conference & Exposition, Nov. 8-10, Atlanta, Ga. Contact Alma McFarland at (404) 447-5083 ext. 224.

National Groundwater Association/Petroleum Hydrocarbons Conference, Nov. 29-Dec. 1, Houston, Texas. Contact Customer Service at (800) 551-7379.





**AIW Inc**  
16300 Katy Freeway No. 250  
Houston, TX 77094  
Phone: 713-578-6733  
Fax: 713-578-6764

**AMARCO Inc (AIHMM)**  
14307 Fox Fire Lane  
San Antonio, TX 78231-1606  
Phone: 210-492-2162  
Fax: 210-408-1563

**A O Smith Harvestor Products Inc**  
345 Harvestore Drive  
DeKalb, IL 60115  
Phone: 815-756-1551  
Fax: 815-756-7821

**A P Buck Inc**  
7101 Prestons Drive No. 110  
Orlando, FL 32809  
Phone: 407-851-8602  
Fax: 407-851-8910

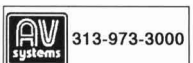

**AV Systems Inc**  
4657 Platt Road  
Ann Arbor, MI 48108-9795  
Phone: 313-973-3000  
Fax: 313-677-4880

**A-Odomaster**  
8th Ave & Pine Ave  
Braddock, PA 15104  
Phone: 412-351-7700  
Fax: 412-351-7701

**AAF International**  
215 Central Ave, PO Box 35690  
Louisville, KY 40232-5690  
Phone: 502-637-0011  
Fax: 502-637-1214



**ABB Air Preheater Inc**  
Andover Road  
Wellsville, NY 14895  
Phone: 716-593-2700  
Fax: 716-593-2721  
**Air Pollution Control Equipment;**  
**Heat Exchangers; Incineration**  
**Systems; Oxidizers; VOC Removal**  
**Systems; Hazardous Waste**  
**Recycling; Odor Control**  
**Equipment**  
**SEE AD ON PAGE 141**

**ABB Environmental Services Inc**  
107 Audubon Road Bldg 3 No. 25  
Waukegan, IL 60087  
Phone: 617-245-6606  
Fax: 617-245-6314

**ABB K-Flow Inc**  
45 Reese Road, PO Box 849  
Millville, NJ 08332  
Phone: 609-825-5553  
Fax: 609-825-3569

**ABB Raymond**  
650 Warrenville Road Third Floor  
Lisle, IL 60532-4349  
Phone: 708-971-2500  
Fax: 708-971-1076

**ABB Sanitec**  
155 Route 46 West  
Wayne, NJ 07470  
Phone: 201-812-8300  
Fax: 201-812-8348

**ACRT Inc Environmental Specialist**  
227 N Depewster St, PO Box 219  
Kent, OH 44240-0219  
Phone: 216-673-8272  
Fax: 216-622-2562

**ACTS Testing Labs Inc**  
25 Anderson Road  
Buffalo, NY 14225  
Phone: 716-897-3300  
Fax: 716-897-0876

**ADA Technologies Inc**  
304 Inverness Way South No. 110  
Englewood, CO 80112

Phone: 303-792-5615  
Natl: 800-232-0296  
Fax: 303-792-5633

**ADS Environmental Services Inc**  
5025 Bradford Blvd  
Huntsville, AL 35805  
Phone: 205-430-3366  
Natl: 800-633-7246  
Fax: 205-430-3961

**AE Environmental Services Inc**  
Wheeling/Ohio County Airport  
No. 200  
Wheeling, WV 26003  
Phone: 304-277-5503  
Fax: 304-277-5505

**AFC Division of MMFG**  
1610 Highway 52 South  
Chatfield, MN 55923  
Phone: 507-867-3479  
Natl: 800-654-2498  
Fax: 507-867-4031



**AFL Industries Inc**  
3661 W Blue Heron Blvd  
Riviera Beach, FL 33404  
Phone: 407-844-5200  
Fax: 407-844-5246

**AGA Gas Inc**  
6225 Oak Tree Blvd  
Independence, OH 44131  
Phone: 216-642-6745  
Fax: 216-642-6746

**AG Consultants Inc**  
1200 19th St NW No. 605  
Washington, DC 20036  
Phone: 202-861-8684  
Fax: 202-775-0137



**AIM Safety USA Inc**  
8403 Cross Park Drive Unit 1A  
Austin, TX 78754  
Phone: 512-832-5665  
Natl: 800-275-4246  
Fax: 512-832-2188

**ANVIC Controls**  
3800 New McEver Road  
Acworth, GA 30101  
Phone: 404-974-7182  
Natl: 800-348-0093  
Fax: 404-974-2959

**APV Heat Transfer/Separation Technologies**  
395 Fillmore Ave  
Tonawanda, NY 14150  
Phone: 716-692-3000  
Fax: 716-692-1715

**ARD Environmental Inc**  
9151 Rumsey Road  
Columbia, MD 21045  
Phone: 410-997-5600  
Natl: 800-969-2731  
Fax: 410-997-3902

**ARDE Barinco Inc**  
500 Walnut St  
Norwood, NJ 07648  
Phone: 201-784-9880  
Fax: 201-784-9710

**ASCF Professionals**  
15075 E Eleven Mile Road  
Roseville, MI 48066

**ASTB/Analytical Services Inc**  
4027 New Castle Ave  
New Castle, DE 19720  
Phone: 302-571-8882  
Natl: 800-221-5170  
Fax: 302-571-0582

**ASTM**  
1916 Race St  
Philadelphia, PA 19103  
Phone: 215-299-5516  
Fax: 215-299-2610

**ATC Environmental Inc**  
600 W Cummings Park No. 6500  
Woburn, MA 01801-6550  
Phone: 617-932-9400

**ATEC Associates Inc**  
8665 Bash St  
Indianapolis, IN 46256-1202  
Phone: 317-577-1761  
Natl: 800-473-0194  
Fax: 317-842-7308

**ATI**  
PO Box 12090  
Lexington, KY 40580  
Phone: 606-231-5898  
Natl: 800-775-1053  
Fax: 606-231-1151

**ATI Orion**  
521 W Main St, The Schaffart Center  
Boston, MA 02129  
Phone: 617-242-3900  
Natl: 800-225-1480  
Fax: 617-242-7885

**AWD Technologies Inc**  
15204 Omega Drive  
Rockville, MD 20850  
Phone: 301-948-0040  
Fax: 301-948-6094

**Aanderaa Instruments Inc**  
73 Second Ave  
Burlington, MA 01803  
Phone: 617-273-2233  
Fax: 617-273-2662

**Aaron Environmental Services Corp**  
2163 Merrick Ave  
Merrick, NY 11566  
Phone: 516-867-7100  
Natl: 800-969-2022  
Fax: 516-867-0600

**Abar Ipsen Industries**  
3260 Tillman Drive  
Bensalem, PA 19020  
Phone: 215-244-4900  
Natl: 800-374-7736  
Fax: 215-244-7954

**Abresit Corp**  
5541 N State Road 13  
Urbana, IN 46990  
Phone: 219-774-3327  
Natl: 800-348-0717  
Fax: 219-774-8188

**Absorbent Products**  
31 Schalen Drive  
Latham, NY 12110  
Phone: 518-783-7118

**Accredited Laboratories Inc**  
PO Box 369  
Carteret, NJ 07008  
Phone: 908-541-2025  
Natl: 800-254-5227  
Fax: 908-541-1383

**AccuStandard Inc**  
25 Science Park  
New Haven, CT 06511  
Phone: 203-786-5290  
Natl: 800-442-5290  
Fax: 203-786-5287

**Accurate Industries**  
1031 Hickstown Road  
Erial, NJ 08081  
Phone: 609-784-5500  
Natl: 800-220-2228  
Fax: 609-346-9118



**Achieve Technology Inc**  
PO Box 868  
Amherst, NH 03031  
Phone: 603-595-1414  
Natl: 800-446-3427  
Fax: 603-595-0088  
**Computer Software, Management;**  
**Computer Software, Regulator;**  
**Computer Software, Training**  
**SEE AD ON PAGE 139**

**Acme Container Co**  
14 S Bryn Mawr Ave No. 206  
Bryn Mawr, PA 19010-3216  
Phone: 610-525-3911  
Fax: 610-525-3912

**Acrison Inc**  
20 Empire Blvd  
Moonachie, NJ 07074  
Phone: 201-440-8300  
Fax: 201-440-4939

**Acromag Inc**  
30765 Wixom Road  
Wixom, MI 48393-7037  
Phone: 810-624-1541  
Natl: 800-336-8655  
Fax: 810-624-9234

**Activated Carbon Resources**  
415 Main St  
Ridgfield, CT 06877  
Phone: 203-438-5508  
Fax: 203-438-5509

**Activated Carbon Technology**  
453 Cranston Drive  
Berea, OH 44017-2206  
Phone: 216-243-6918

**Adirondack Environmental Associates Inc**  
9 Kasner Road  
Flattsburgh, NY 12091  
Phone: 518-583-5726  
Natl: 800-257-3000  
Fax: 518-582-0789

**Admiral Environmental Services Inc**  
2025 S Arlington Heights Rd No. 103  
Arlington Heights, IL 60005  
Phone: 708-228-5355

**Advance Machine Co**  
14600 21st Ave  
Plymouth, MN 55447  
Phone: 612-473-2235  
Fax: 612-475-9718

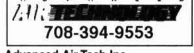

**Advanced Air Tech Inc**  
3800 N Wilke Road No. 175  
Arlington Heights, IL 60004-9757  
Phone: 708-394-9553  
Fax: 708-394-9757

**Advanced Control Systems**  
Old Mine Rock Way  
Hingham, MA 02043  
Phone: 617-740-0223  
Fax: 617-740-4227

**Advanced Environmental Recycling Corp**  
2591 Mitchell Ave  
Allentown, PA 18103  
Phone: 610-797-7608  
Natl: 800-554-2372  
Fax: 610-797-7696

**Advanced Industrial Technology Corp**  
PO Box 453  
Paramus, NJ 07653  
Phone: 201-265-1414  
Fax: 201-262-8457

**Advanced Microbial Systems Inc**  
PO Box 239  
Shakopee, MN 55379  
Phone: 612-445-4251  
Fax: 612-445-7233

**Advanced Polymer Sciences Inc**  
PO Box 269, 951 Jaycox Drive  
Avon, OH 44011  
Phone: 216-937-6218  
Natl: 800-334-7193  
Fax: 216-937-5046

**Advanced Technology Laboratories**  
1510 E 33rd St  
Signal Hill, CA 90807  
Phone: 310-989-4045  
Natl: 800-499-4388  
Fax: 310-989-4040



**Adwest Technologies Inc**  
803 W Angus Ave  
Orange, CA 92668  
Phone: 714-997-8722  
Fax: 714-997-8744  
**Air Pollution Control Equipment;**  
**Burners; Catalysts; Heat**  
**Exchanges; Heat Recovery**  
**Systems; Incineration Systems;**  
**Odor Control Equipment;**  
**Oxidizers; Solvent Recovery**  
**Systems; VOC Removal Systems**  
**SEE AD ON PAGE 36**

**Aerology Inc**  
8 Custom Drive  
Old Saybrook, CT 06475  
Phone: 203-399-7941  
Natl: 800-826-6123  
Fax: 203-399-7049

**Aerial Viewpoint**  
10200 Richmond Ave No. 140  
Houston, TX 77042  
Phone: 713-784-5801  
Natl: 800-784-5801  
Fax: 713-784-5802

**Aero Tec Laboratories**  
Spear Road Industrial Park  
Ramsay, NJ 07446-1251  
Phone: 201-825-1400



**Aeromix Systems Inc**  
2611 N Second St  
Minneapolis, MN 55411  
Phone: 612-521-8519  
Natl: 800-879-3677  
Fax: 612-521-1455

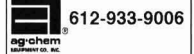

**Ag-Chem Equipment Co**  
5720 Smetana  
Minnetonka, MN 55343  
Phone: 612-933-9006

**Agar Corp**  
PO Box 802127  
Houston, TX 77280  
Phone: 713-464-4451  
Fax: 713-464-7741

**Agency Information Consultants Inc (AIC)**  
1708 Guadalupe St  
Austin, TX 78701  
Phone: 512-478-8991  
Natl: 800-945-9509  
Fax: 512-478-5215

**Agel Manufacturing Co**  
1408 E Church St, PO Box 248  
Adrian, MI 49221  
Phone: 517-263-5781  
Fax: 517-263-7154

**Air & Waste Management Association**  
One Gateway Center, Third Floor  
Pittsburgh, PA 15222  
Phone: 412-232-3444  
Natl: 800-270-3444  
Fax: 412-232-3450

**Air Dimensions Inc**  
1015 W Newport Ctr No. 101  
Deerfield Beach, FL 33442  
Phone: 305-428-7333  
Natl: 800-423-6464  
Fax: 305-360-0987

**Air Instruments & Measurements Inc**  
13300 A Brooks Drive  
Baldwin Park, CA 91706  
Phone: 818-813-1460  
Natl: 800-969-4246  
Fax: 818-338-2585

**Air Metrics**  
225 N 5th St No. 501  
Springfield, OR 97477  
Phone: 503-726-0560  
Fax: 503-726-1205

**Air Monitor Corp**  
1050 Hopper Ave  
Santa Rosa, CA 95406  
Phone: 707-544-2706  
Natl: 800-247-3569  
Fax: 707-526-2825

**Air Plastics Inc**  
1224 Castle Drive  
Mason, OH 45040-9409  
Phone: 513-398-8081  
Fax: 513-398-8082

**Air Quality Engineering**  
3240 Wingo Rd  
Minneapolis, MN 55427  
Phone: 612-544-4426  
Natl: 800-328-0787  
Fax: 612-544-4013

**Air Resource Specialists Inc**  
1901 Sharp Point Drive No. E  
Fort Collins, CO 80525  
Phone: 303-484-7941  
Fax: 303-484-3423

**Air Science Consultants**  
347 Prestley Road  
Bridgeville, PA 15017-1949  
Phone: 412-221-6000  
Fax: 412-221-3160

**Air Technical Industries**  
7501 Clover Ave  
Mentor, OH 44060  
Phone: 216-951-5919  
Natl: 800-321-9880  
Fax: 216-953-9237

**AirSep Corp**  
290 Creekside Drive  
Buffalo, NY 14228-0202

Phone: 716-691-0202  
 Natl: 800-874-0202  
 Fax: 716-691-0707



**Airdomes Inc**  
 7861 SW Nimbus Ave  
 Beaverlton, OR 97008  
 Phone: 503-641-3663  
 Fax: 503-646-9942



**Airx Div Adwest Technologies**  
 151 Trapping Brook Road  
 Wellsville, NY 14895-9465  
 Phone: 716-593-1405  
 Fax: 716-593-6614

**Airotech**  
 Boyle Cir/120 9th Ave  
 Homestead, PA 15120  
 Phone: 412-462-4404  
 Fax: 412-462-8816

**Airscan Environmental**  
 PO Box 419  
 Whitehouse, NJ 08888-0419  
 Phone: 908-725-1342  
 Natl: 800-639-2477  
 Fax: 908-725-0822

**Airscan Environmental Technologies Inc**  
 197 Meister Ave  
 Branchburg, NJ 08876  
 Phone: 908-725-1342  
 Natl: 800-639-2477  
 Fax: 908-725-0822



**Alar Engineering Corp**  
 9651 196th St  
 Mokena, IL 60448-9307  
 Phone: 708-479-6100  
 Fax: 708-479-9059

**Alliflex Hazardous Material Packing Inc**  
 100 Race St  
 Ambler, PA 19002  
 Phone: 215-542-9208  
 Natl: 800-449-2467  
 Fax: 215-643-3339

**Alliance Environmental Inc**  
 117 Industry Road  
 Marietta, OH 45750  
 Phone: 614-373-2190  
 Fax: 614-374-5908



**Allied-Signal Inc**  
 Environmental Catalysts  
 PO Box 580970  
 Tulsa, OK 74158  
 Phone: 918-266-1400  
 Fax: 918-266-4981

**Allied-Signal Inc**  
 Filtration Systems  
 7 Powder Horn Drive, PO Box 4904  
 Warren, NJ 07059-5191  
 Phone: 908-563-2800  
 Fax: 908-563-2816

**Alnor Instrument Co**  
 7555 N Linder Ave  
 Skokie, IL 60085  
 Phone: 708-677-3500  
 Fax: 708-677-3539



**Alta Resource Management Services Inc**  
 88B Industry Ave  
 Springfield, MA 01104  
 Phone: 413-734-3399  
 Natl: 800-730-2582  
 Fax: 413-734-3475



**Alternative Systems Inc**

225 S Cabrillo Highway  
 Half Moon Bay, CA 94019  
 Phone: 415-726-5700  
 Fax: 415-726-7846

**Alton Geosience**  
 25 A Technology Drive No. 200  
 Irvine, CA 92718  
 Phone: 714-753-0101  
 Fax: 714-753-0111

**Amadas Industries**  
 1100 Holland Road  
 Suffolk, VA 23434  
 Phone: 804-539-0231

**Ambient Engineering Inc**  
 180 Highway 34  
 Matawan, NJ 07747  
 Phone: 908-566-6866  
 Natl: 800-732-4155  
 Fax: 908-566-7722

**Ameri-Shred Corp**  
 PO Box 46130  
 Monroeville, PA 15146  
 Phone: 412-823-4222  
 Natl: 800-634-8981  
 Fax: 412-823-2451



**American Engineering**  
 15886 Michigan Road  
 Argos, IN 46501  
 Phone: 219-892-5151  
 Fax: 219-892-5150

**American EnviroSpect Inc**  
 PO Box 99  
 Noblesville, IN 46060  
 Phone: 317-773-8270  
 Natl: 800-876-8879  
 Fax: 317-773-8308

**American Environmental International Inc**  
 725 W University Drive  
 Arlington Heights, IL 60004  
 Phone: 708-342-8600  
 Fax: 708-342-8500

**American Gas Products Inc**  
 1513 W Dogwood Ave  
 Anaheim, CA 92801  
 Natl: 800-201-6700  
 Fax: 714-776-6700

**American Lewa Inc**  
 132 Hopping Brook Road  
 Holliston, MA 01746  
 Phone: 508-429-7403  
 Fax: 508-429-9615

**American Pulverizer Co**  
 5540 W Park Ave  
 St Louis, MO 63110-1897  
 Phone: 314-781-6100  
 Fax: 314-781-9209

**American Roloff**  
 PO Box 5757, 3 Tennis Court  
 Trenton, NJ 08638  
 Phone: 609-588-3400  
 Fax: 609-588-4104

**American Safety Products Inc**  
 PO Box 360883  
 Milpitas, CA 95036  
 Phone: 408-262-1909  
 Fax: 408-262-0660



**American Safety Risk Retention Group Inc**  
 1900 The Exchange No. 450  
 Atlanta, GA 30339  
 Phone: 404-916-1908  
 Natl: 800-388-3647  
 Fax: 404-916-0618  
 Insurance  
 SEE AD ON PAGE 32

**American Scientific Instrumentation**  
 107 Hawthorne Ave  
 Park Ridge, NJ 07656  
 Phone: 201-391-0922  
 Fax: 201-391-6804

**American Sigma Inc**  
 PO Box 820  
 Medina, NY 14103  
 Phone: 716-798-5580  
 Natl: 800-635-4567  
 Fax: 716-798-5599

**American Standards Testing Bureau Inc**  
 40 Water St  
 New York, NY 10004  
 Phone: 212-943-3160  
 Natl: 800-221-5170  
 Fax: 212-925-2250



**Ameron**  
 315 W Lime Ave  
 Monrovia, CA 91016  
 Phone: 818-359-3960

**Ameron Fiberglass Pipe Systems**  
 13405 NW Freeway No. 117  
 Houston, TX 77040  
 Phone: 713-690-7777  
 Fax: 713-690-2842

**Ameron Inc**  
 245 S Los Robles Ave  
 Pasadena, CA 91101  
 Phone: 818-683-4000  
 Fax: 818-683-4060

**Ametek Inc**  
 455 Corporate Blvd  
 Newark, DE 19702  
 Phone: 302-456-4480  
 Natl: 800-222-6789  
 Fax: 302-456-4444

**Ametek Inc/Panalarm Div**  
 7401 N Hamlin Ave  
 Skokie, IL 60076  
 Phone: 708-675-2500  
 Fax: 708-675-3111



**Amfuel**  
 124 S Jackson  
 Magnolia, AR 71753  
 Phone: 501-235-7297  
 Fax: 501-235-7270

**Amoco Fibrics & Fibers Co**  
 900 Circle 75 Parkway No. 550  
 Atlanta, GA 30339  
 Phone: 404-984-4480  
 Fax: 404-618-4038

**Anarad Inc**  
 534 E Ortega St  
 Santa Barbara, CA 93103  
 Phone: 805-363-6583  
 Fax: 805-362-4627

**Anatel Corp**  
 2200 Central Ave  
 Boulder, CO 80301  
 Phone: 303-442-5533  
 Fax: 303-447-8365

**Andco Environmental Processes Inc**  
 595 Commerce Drive  
 Buffalo, NY 14228-2380  
 Phone: 716-691-2100  
 Fax: 716-691-2880

**Anderson 2000 Inc**  
 306 Dividend Drive  
 Peachtree, GA 30269  
 Phone: 404-486-2000  
 Natl: 800-241-5424  
 Fax: 404-487-5066

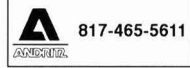

**Andritz Ruthner Inc**  
 1010 Commercial Blvd South  
 Arlington, TX 76011  
 Phone: 817-465-5611  
 Fax: 817-468-3961

**Angevine Acoustical Consultants Inc**  
 PO Box 725  
 East Aurora, NY 14052-0725  
 Phone: 716-652-0828  
 Natl: 800-836-3834  
 Fax: 716-652-3442

**Anguil Environmental Systems Inc**  
 4927 N Lydell Ave  
 Milwaukee, WI 53217  
 Phone: 414-332-0230  
 Fax: 414-332-4375

**Antek Instruments Inc**  
 300 Bammel Westfield Road  
 Houston, TX 77090-3508  
 Phone: 713-580-0339

Natl: 800-365-2143  
 Fax: 713-580-0719



**Applied Automation/Hartman & Braun**  
 PO Box 9999  
 Bartlesville, OK 74005  
 Phone: 918-662-7343  
 Fax: 918-662-7052

**Hydrocarbon Detectors; Industrial Hygiene; Monitoring Systems; Air Monitoring Systems; Water Sampling Systems; Stack Emissions Monitors**  
 SEE AD ON PAGE 164

**Applied Research & Development Lab**  
 PO Box 1566  
 Mount Vernon, IL 62864  
 Phone: 618-244-3235  
 Natl: 800-842-7134  
 Fax: 618-244-1149

**Applied Science & Technology Inc**  
 7879 Jackson Road  
 Ann Arbor, MI 48103  
 Phone: 313-426-1200  
 Natl: 800-395-2784  
 Fax: 313-426-1209

**Aqua Tech Industries Inc**  
 11100 Golden Leaf Road  
 Richmond, VA 23237-3994  
 Phone: 804-796-4784  
 Fax: 804-796-1750

**Aqua-Chem Inc**  
 7800 N 113th St  
 Milwaukee, WI 53224  
 Phone: 414-359-0600  
 Fax: 414-577-2723

**Aqua Tec Inc**  
 1233 Shupert Drive  
 Rockford, IL 61115  
 Phone: 815-364-1500  
 Natl: 800-654-1505  
 Fax: 815-654-0038

**Arc-Power Utilized Fueler Inc**  
 108 Smithtown Blvd  
 Smithtown, NY 11787  
 Phone: 516-366-4362  
 Natl: 800-242-2736  
 Fax: 516-366-0905

**Ariel Industries Inc**  
 2204 Industrial South Road  
 Dalton, GA 3074  
 Phone: 706-277-7070  
 Fax: 706-277-7945

**Arizona Instrument Corp**  
 4114 E Wood St  
 Phoenix, AZ 85040-1941  
 Phone: 602-470-1414  
 Natl: 800-528-7411  
 Fax: 602-470-1888



**Art's Manufacturing & Supply (AMS)**  
 105 Harrison  
 American Falls, ID 83211  
 Phone: 208-226-2017  
 Natl: 800-635-7330  
 Fax: 208-226-2878  
 Computer Modeling (Air, Groundwater, Hazard & Risk; Core Sampler; Groundwater Testing & Monitoring Equipment; Hydrocarbon Detectors; Level Instruments; Monitoring Systems; Water; pH Instrumentation; Pumps; Sludge, wastewater, groundwater, misc.); Sampling Systems; Soil Sampling Equipment; Temperature Instrumentation; Underground Tank Leak Monitors; Vapor Recovery  
 SEE AD ON PAGE 53

**Artesian Environmental**  
 3100 Kerner Blvd, Suite C  
 San Rafael, CA 94901  
 Phone: 415-257-4801  
 Fax: 415-257-4805

**Arthur D Little Inc**  
 20 Acorn Park  
 Cambridge, MA 02140-2390  
 Phone: 617-498-6153  
 Fax: 617-498-7161

**Arthur Technology Inc**  
 PO Box 1236  
 Fond du Lac, WI 54936-1236  
 Phone: 414-922-6970  
 Natl: 800-328-7518  
 Fax: 414-922-1085

**Asahi/America Inc**  
 19 Green St  
 Malden, MA 02148  
 Phone: 617-321-5409  
 Natl: 800-343-3618  
 Fax: 617-321-8467

**Ashbrook Corp**  
 11600 E Hardy  
 Houston, TX 77093  
 Phone: 713-449-0322  
 Fax: 713-449-1324

**Assay Technology Inc**  
 1070 E Meadow Circle  
 Palo Alto, CA 94303  
 Phone: 415-424-9944  
 Natl: 800-833-1258  
 Fax: 415-424-0336

**Asman Corp of America**  
 300 N Taylor Road  
 Garrett, IN 46738  
 Phone: 219-357-3181  
 Fax: 219-357-3738

**Associated Design & Mfg**  
 141 S Henry St  
 Alexandria, VA 22314-1689  
 Phone: 703-549-5999  
 Natl: 800-837-8257  
 Fax: 703-548-0919

**Atkomatic Valve Co Inc**  
 141 S Sherman Drive  
 Indianapolis, IN 46201  
 Phone: 317-357-8421  
 Natl: 800-225-4374  
 Fax: 317-357-0149

**Atlantic Screen & Mfg Inc**  
 118 Broadkill Road  
 Milton, DE 19968  
 Phone: 302-684-3197  
 Fax: 302-684-0643

**Atlantic Testing Laboratories Limited**  
 PO Box 29, Canton-Potsdam Road  
 Canton, NY 13611  
 Phone: 315-386-4578  
 Fax: 315-386-1012

**Atlantic Ultraviolet Corp**  
 375 Marcus Blvd  
 Hauppauge, NY 11788  
 Phone: 516-273-0500  
 Fax: 516-273-0771

**Atlas Minerals & Chemicals Inc**  
 Farmington Road  
 Merztown, PA 19539  
 Phone: 610-682-7171  
 Natl: 800-523-8269  
 Fax: 610-682-9200



**Auburn International Inc**  
 PO Box 2008, Danvers  
 Industrial Park  
 Danvers, MA 01923  
 Phone: 508-777-2460  
 Natl: 800-255-5068  
 Fax: 508-777-8820

**Air Emission Monitoring Equipment; Air Pollution Control Equipment; Annunciators/Alarms; Baghouse Monitoring; Detectors; Dust Collector Accessories/Supplies; Dust Collector Controls; Flow Instrumentation; Flowmeters; Mass; Monitoring Systems; Air; Monitoring Systems; Hazardous Material; Particle Detectors; Process Control Instrumentation; Sensors; Stack Emission Monitors**  
 SEE AD ON PAGE 53

**Automatic Switch Co (ASCO)**  
 60 Hanover Road  
 Florham Park, NJ 07932-1503  
 Phone: 201-966-2000  
 Natl: 800-972-2726  
 Fax: 201-966-2628

**Automation Products Inc**  
 3030 Max Box St  
 Houston, TX 77008  
 Phone: 713-869-0361  
 Natl: 800-231-2062  
 Fax: 713-869-7332

### Regenerative Thermal Oxidizers

- 2,000 to 500,000 SCFM
- Efficient, Reliable, Durable

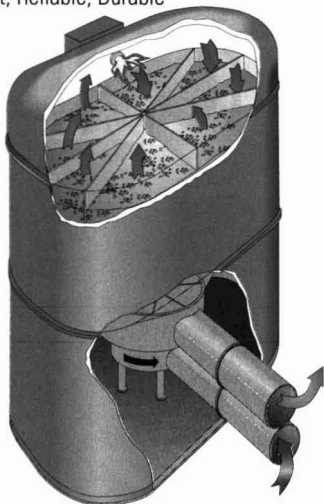

### Catalytic & Regenerative Catalytic Oxidizers

- Lowest Operating Cost
- High Destruction Efficiency

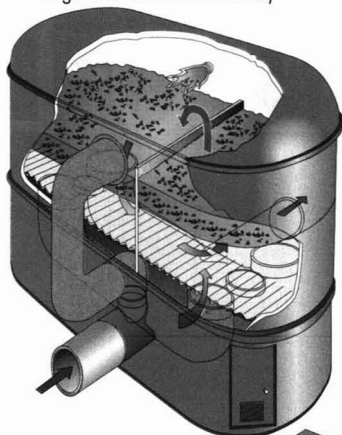

- Catalysts for**
- VOC
  - NO<sub>x</sub>
  - CO
  - Chlorinated Hydrocarbons

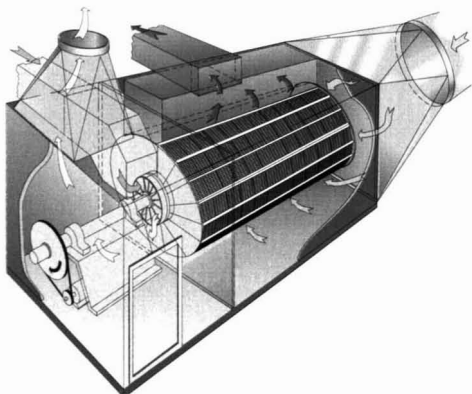

### VOC Concentrator Systems

- Zeolite
- Activated Carbon

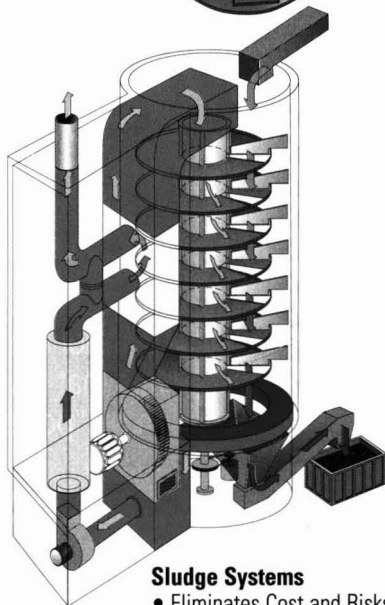

### Sludge Systems

- Eliminates Cost and Risks of Landfill
- Reduction and Drying Equipment

# Environmental Professionals Rely On Us

*We Build Environmental Solutions*

- Fast, Accurate Technical Support
- Alternative Technologies
- Process Interface Knowledge
- Best Equipment Value
- Turn-Key Installations

*For more information contact*

**SALEM ENGELHARD**

245 S. Mill Street • South Lyon, MI 48178 • (810) 437-1400 • Fax (810) 437-7924

Circle 87 on card.

# Eco-Logical.

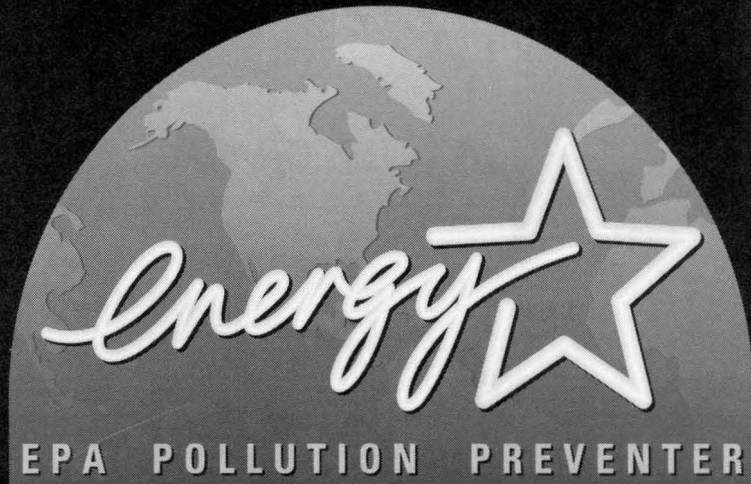

This symbol identifies energy-efficient computers that save you money and reduce air pollution by "powering down" when not in use.

Over 2000 computers, monitors and printers have earned the right to bear the Environmental Protection Agency's Energy Star<sup>SM</sup> logo. These computers are so smart, they go to sleep when not in use and wake up with a simple touch of the keyboard or mouse. Energy Star<sup>SM</sup> Computers don't cost any extra, will

save money on your energy bill, and prevent pollution from electricity generation. Be part of the solution and look for this logo when you make your next computer purchase. To receive a list of available products call the Energy Star<sup>SM</sup> Hotline at 202 775-6650.

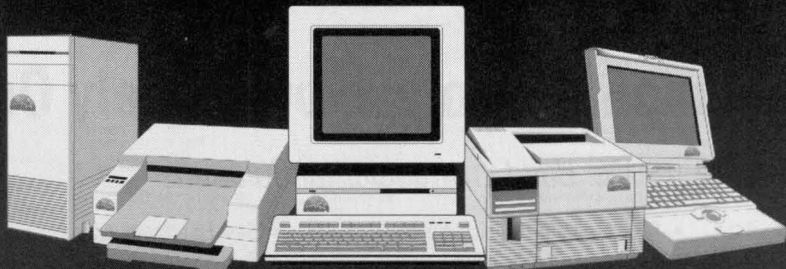

*Buy It And Save.*

**B**

**B & W NESI NEL**  
Mount Athos Road, PO Box 11165  
Lynchburg, VA 24506-1165  
Phone: 804-522-6755  
Fax: 804-522-5572

**B A G Corp**  
11510 Data Drive  
Dallas, TX 75218  
Phone: 214-340-7060  
Fax: 214-340-4598

**B-J Scientific Products Inc**  
173 Queen Ave Southeast  
Albany, OR 97321  
Phone: 503-967-8383  
Fax: 503-928-0596

**BEC Laboratories**  
705 Front St  
Toledo, OH 43605  
Phone: 419-693-5307  
Fax: 419-691-0418

**BEM Systems Inc**  
8 Vreeland Road  
Florham Park, NJ 07932  
Phone: 201-301-0078  
Fax: 201-301-0149

**BNA Communications Inc**  
939 Kay West Ave  
Rockville, MD 20850-3396  
Phone: 800-217-2338  
Fax: 301-948-2085

**BRD Noise & Vibration Control Inc**  
112 Fairview Ave  
Wind Gap, PA 18091  
Phone: 610-863-8300  
Fax: 610-863-4230

**BVS** 610-273-2841

**BVS Inc**  
Route 322 West & Poplar Road  
Honey Brook, PA 19344-0250  
Phone: 610-273-2841  
Fax: 610-273-2843

**Babcock & Wilcox**  
PO Box 351  
Barberton, OH 44203-0351  
Phone: 216-753-4511  
Fax: 800-222-2625  
Fax: 216-860-1886

**Bacharach Inc**  
625 Alpha Drive  
Pittsburgh, PA 15238  
Phone: 412-963-2000  
Fax: 412-963-2091

**Bacteria Concepts Inc**  
1400 Brook Drive  
Downers Grove, IL 60515-1025  
Phone: 708-261-0061  
Fax: 800-343-5255  
Fax: 708-261-0064

**Badger Meter**  
414-355-0400

**Badger Meter Inc**  
4545 W Brown Deer  
Milwaukee, WI 53223  
Phone: 414-355-0400  
Fax: 800-876-3837  
Fax: 414-355-2544  
Flow Instrumentation: Flue Gas  
Desulfurization; Level  
Instrumentation; Meters;  
Stormwater Monitoring  
SEE AD ON PAGE 4

**Bailey Controls Co**  
29801 Euclid Ave  
Wickliffe, OH 44092  
Phone: 216-585-9500  
Fax: 216-585-8756

**Bailey-Fischer & Porter Co**  
125 E County Line Road  
Warminster, PA 18974  
Phone: 215-674-6000  
Fax: 800-829-6001  
Fax: 215-674-7163

**Baker Tanks**  
19618 S Susana Road  
Rancho Dominguez, CA 90221

**Baler Equipment Co**

PO Box 25150  
Portland, OR 97225  
Phone: 503-292-4118  
Natl: 800-426-1723  
Fax: 503-297-5991

**Bally Engineered Structures Inc**  
135 Little Nine Drive  
Morehead, NC 28557  
Phone: 919-240-2829  
Fax: 919-240-0384

**Balston Inc**  
260 Neck Road Box 8223  
Haverhill, MA 01835  
Phone: 508-374-7400  
Natl: 800-343-4048  
Fax: 508-374-7070

**Barnatt Co**  
28W092 Commercial Ave  
Barrington, IL 60010  
Phone: 708-381-7050  
Natl: 800-637-3739  
Fax: 708-381-7053

**Barneby & Sutcliffe Corp**  
PO Box 2526  
Columbus, OH 43216  
Phone: 614-258-9501  
Fax: 614-258-3464

**Barnes Pumps Inc (Sub of Crane Pumps & Systems Inc)**  
1485 Lexington Ave  
Mansfield, OH 44907  
Phone: 419-774-1511  
Fax: 419-774-1530

**Barr Engineering Co**  
8300 Norman Center Drive  
Minneapolis, MN 55437-1026  
Phone: 612-832-2600  
Natl: 800-632-2277  
Fax: 612-832-2601

**Bascom-Turner Instruments**  
111 Downey St  
Norwood, MA 02062  
Phone: 617-769-9660  
Natl: 800-225-3298  
Fax: 617-551-0283

**Beardsley, Brown & Bassett Inc**  
1000 Lafayette Blvd  
Bridgeport, CT 06604  
Phone: 203-366-1815  
Fax: 203-366-8561

**Beckart Environmental Inc**  
6900 46th St  
Kenosha, WI 53144  
Phone: 414-656-7680  
Fax: 414-656-7699

**Beko Condensate Systems Corp**  
4140 Tuller Road No. 108  
Dublin, OH 43017  
Phone: 614-798-5275  
Fax: 614-798-5276

**Beltran Associates Inc**  
1133 E 35th St  
Brooklyn, NY 11210-4299  
Phone: 718-338-3311  
Fax: 718-253-9028

**Ben Meadows**  
3589 Broad St  
Atlanta, GA 30341  
Phone: 404-455-0907  
Natl: 800-241-6401  
Fax: 404-457-1841

**Benko Products Inc**  
24500 Center Ridge Road  
Westlake, OH 44145  
Phone: 216-835-8070  
Fax: 216-835-8693

**Bergen Barrel & Drum**  
43-45 O'Brien St  
Kearny, NJ 07032  
Phone: 201-998-3500  
Fax: 201-998-0414

**Bes-Pac Inc**  
PO Box 2049  
Easley, SC 29641  
Phone: 803-859-6030  
Natl: 800-726-1439  
Fax: 803-859-6414

**Best Manufacturing Co**  
PO Box 8, Edison St  
Menlo, GA 30731  
Phone: 706-862-2302  
Natl: 800-241-0323  
Fax: 706-862-6000

**Bete Fog Nozzle Inc**  
50 Greenfield St, PO Box 311  
Greenfield, MA 01301  
Phone: 413-772-0846

**Bicron, Harshaw/Bicron Radiation Measurement Products**  
6801 Cochran Road  
Solon, OH 44139  
Phone: 216-248-7400  
Natl: 800-472-5656  
Fax: 216-349-6581

**Bio-Systems Corp**  
PO Box 330  
Roscoe, IL 61073  
Phone: 608-365-9550  
Natl: 800-232-2847  
Fax: 608-365-9467

**BioTrol Inc**  
10300 Valley View Road  
Eden Prairie, MN 55344  
Phone: 612-942-8032  
Fax: 612-942-8526

**Biochemery Inc**  
456 Creamery Way  
Exton, PA 19341-2532  
Natl: 800-524-8800  
Fax: 610-524-8807

**Blomin Inc**  
PO Box 20028  
Ferndale, MI 48220  
Phone: 810-544-2552  
Natl: 800-959-0830  
Fax: 810-544-3733

**Bios Intl**  
230 W Parkway Unit 1  
Pompton Plains, NJ 07444

**Bioscience Inc**  
1550 Valley Center Parkway No. 140  
Bethlehem, PA 18017  
Phone: 610-974-9693  
Natl: 800-627-3069  
Fax: 610-691-2170

**Biosystems**  
PO Box 158  
Rockfall, CT 06481  
Phone: 203-344-1079  
Fax: 203-344-1068

**Bird-X Inc**  
730 W Lake St  
Chicago, IL 60661  
Phone: 312-648-2191  
Natl: 800-662-5021  
Fax: 312-648-0319

**Bird Machine Co Inc**  
100 Neponset St  
South Walpole, MA 02071  
Phone: 508-668-0400  
Fax: 508-668-8855

**Bixby International Corp**  
One Prable Road  
Newburyport, MA 01950  
Dublin, OH 43017  
Phone: 508-465-5184

**Blackmer Pump/DVR Res**  
1809 Century Ave Southwest  
Grand Rapids, MI 49509  
Phone: 616-241-1611  
Fax: 616-241-3752

**Blasland Bouck & Lee Inc**  
6723 Towpath Road, PO Box 66  
Syracuse, NY 13214-0066  
Phone: 315-446-9120  
Fax: 315-449-0017

**Blower Application Co**  
N114 W19125 Clinton Drive  
Germantown, WI 53022  
Phone: 414-255-5580  
Fax: 414-255-3446

**Bock Environmental Service Inc**  
3108 Rolling Acres Plz No. A  
Valrico, FL 33954  
Phone: 813-654-4880  
Fax: 813-653-3000

**Bohn Blowlift Corp**  
PO Box 44235  
Tucson, AZ 85733  
Phone: 602-624-4644  
Fax: 602-621-1647

**Bonding & Insurance**  
717 S Wells St  
Chicago, IL 60607  
Phone: 312-427-2951  
Natl: 800-346-1713  
Fax: 312-427-4581

**Bore Products Inc**  
2879 Aero Park Drive  
Traverse City, MI 49686-9170

Phone: 616-946-2100  
Fax: 616-946-3025

**Boston Gear**  
14 Hayward St  
Quincy, MA 02171  
Phone: 617-328-3300  
Natl: 800-225-5280  
Fax: 617-479-6238

**Bowman Environmental Engineering Inc**  
PO Box 59916  
Dallas, TX 75229  
Phone: 214-233-5463  
Fax: 214-233-3299

**Brailsford & Company**  
670 Milton Road  
Rye, NY 10580-3297  
Phone: 914-967-1820  
Fax: 914-967-1836

**Bran & Luebbe Inc**  
1025 Busch Parkway  
Buffalo Grove, IL 60089-4516  
Phone: 708-520-0700  
Fax: 708-520-0855

**Braun Intertec Corp**  
PO Box 39108  
Minneapolis, MN 55439-0108  
Phone: 612-946-6000  
Natl: 800-279-6100  
Fax: 612-946-6190

**Breslove Separator Co Inc**  
550 Butler St  
Pittsburgh, PA 15223  
Phone: 412-782-0309  
Fax: 412-782-3509

**Bristol Babcock Inc**  
1100 Buckingham St  
Watertown, CT 06795-1699  
Phone: 203-575-3000  
Natl: 800-395-5497  
Fax: 203-575-3170

**Brooklyn Thermometer Co Inc**  
Nirely Verd St  
Farmingdale, NY 11735-6318  
Phone: 516-694-7610  
Fax: 516-694-6329

**Brooks Instrument**  
407 W Vine St  
Hatfield, PA 19440  
Phone: 215-362-3500  
Fax: 215-362-3745

**Brown & Root Environmental**  
10200 Bellaire Blvd  
Houston, TX 77072  
Phone: 713-575-3000  
Fax: 713-575-4537

**Brown Bear Corp**  
PO Box 29  
Corning, IA 50841  
Phone: 515-322-4220  
Fax: 515-322-3527

**Brown Minneapolis Plant**  
2875 Highway 55  
Eagan, MN 55121-1429

**Bruel & Kjaer Instruments**  
2364 Park Central Blvd  
Decatur, GA 30035  
Phone: 404-981-9311  
Natl: 800-252-4871  
Fax: 404-981-9303

**Bryan Steam Corp**  
PO Box 27  
Peru, IN 46970  
Phone: 317-473-6651  
Fax: 317-473-8074

**Burns & McDonnell**  
4800 E 63rd St  
Kansas City, MO 64130  
Phone: 816-333-4375  
Fax: 816-333-3690

**Busch Inc**  
516 Viking Drive  
Virginia Beach, VA 23452  
Phone: 804-463-7800  
Natl: 800-872-7867  
Fax: 804-463-7407

**C**

**C2T Group Ltd**  
717-10 Steirway St  
Astoria, NY 11105  
Phone: 718-721-1335  
Fax: 718-721-1401

**CAE Express**  
500 W Wood St  
Palatine, IL 60067

Phone: 708-991-3300  
Natl: 800-223-3977  
Fax: 708-991-6577

**CAE Instrument Rental**  
246 Woodwork Lane  
Palatine, IL 60067  
Phone: 708-934-8668  
Natl: 800-553-5511  
Fax: 708-934-8260

**CEA Instruments**  
16 Chestnut St  
Emerson, NJ 07630-1169  
Phone: 201-967-5660  
Fax: 201-967-8450

**CEM Corp**  
PO Box 200, 3100 Smith Farm Road  
Matthews, NC 28206  
Phone: 704-821-7015  
Natl: 800-726-3331  
Fax: 704-821-7894

**CET Environmental Services Inc**  
14761 Bentley Circle  
Tustin, CA 92680  
Phone: 714-505-1800  
Natl: 800-753-1818  
Fax: 714-505-0987

**CHEM-Tel Inc**  
PO Box 290156  
Temple Terrace, FL 33687  
Phone: 813-979-0626  
Fax: 813-979-4620

**CHEMetrics Inc**  
Route 28  
Calverton, VA 22016  
Phone: 703-788-9026  
Natl: 800-356-3072  
Fax: 703-788-4856

**CMI-Schnelbein Co**  
714 N Saginaw St  
Holy, MI 48442  
Phone: 810-634-8211  
Natl: 800-627-6508  
Fax: 810-634-2240

**COMCO, INC.**  
ENVIRONMENTAL & SAFETY SERVICES  
310-804-0305

**COMCO Inc**  
17120 Clark Ave  
Bellflower, CA 90706-5730  
Phone: 310-804-0305  
Fax: 310-925-4248

**CORTEC Corp**  
4119 White Bear Parkway  
St Paul, MN 55110  
Phone: 612-429-1100  
Fax: 612-429-1122

**CPI**  
602-423-0119

**CPI (Citation Publishing Inc)**  
7505 East main St No. 400  
Scottsdale, AZ 85251  
Phone: 602-423-0119  
Fax: 602-423-5331  
SEE AD ON PAGE 48

**CRK Environmental Services Inc**  
PO Box 932  
Pittsburgh, PA 15225  
Phone: 412-262-0734  
Fax: 412-262-2250

**CSM Environmental Systems Inc**  
Brooklyn Navy Yard Bldg 12  
Brooklyn, NY 11205  
Phone: 718-522-7000  
Fax: 718-852-1686

**CTL Environmental Services**  
24404 S Vermont Ave No. 307  
Harbor City, CA 90710  
Phone: 310-536-0006  
Natl: 800-777-0600  
Fax: 310-530-0792

**CVM Corp**  
402 Vandever Ave  
Wilmington, DE 19802  
Phone: 302-654-7070  
Fax: 302-654-2772

**Cabot Safety Corp**  
90 Mechanic St  
Southbridge, MA 01550  
Phone: 508-764-5580  
Natl: 800-224-9038

Fax: 800-488-8007

**Calgon Carbon Corp**  
PO Box 717  
Pittsburgh, PA 15230-0717  
Phone: 412-787-6700  
Natl: 800-422-7266  
Fax: 412-787-6324

**California Analytical Instruments Inc**  
1238 West Grove  
Orange, CA 92665  
Phone: 714-974-5560  
Fax: 714-921-2531

**Cameron-Yakima Inc**  
PO Box 1554  
Yakima, WA 98907-1554  
Phone: 509-452-6605  
Natl: 800-507-3228  
Fax: 509-453-9912

**Campbell Scientific Inc**  
815 W 1800 North  
Logan, UT 84321-1784  
Phone: 801-753-2342  
Fax: 801-752-3268

**Capital Controls Co Inc**  
PO Box 211  
Colmar, PA 18915  
Phone: 215-997-4000  
Fax: 215-997-4062

**Captain Lab Inc**  
One Elm Street, Route 114  
North Andover, MA 01845  
Phone: 508-975-3336  
Natl: 800-964-4434  
Fax: 508-975-2730

**Carbon Activated**  
1442 W 135th Street  
Gardena, CA 90249  
Phone: 310-323-8132  
Fax: 310-323-8366

**Carbon Service & Equipment Co**  
PO Box 838  
Donora, PA 15033  
Phone: 412-379-8032  
Fax: 412-379-7780

**Carbonair Environmental Systems**  
8640 Monticello Lane  
Maple Grove, MN 55369-4547  
Phone: 612-425-2992  
Natl: 800-526-4999  
Fax: 612-425-6882

**Carbomchem Inc**  
551 Lancaster Ave  
Haverford, PA 19041  
Phone: 610-527-0808  
Fax: 610-527-6422

**Carbrol Corp**  
51 Riverside Ave  
Westport, CT 06880  
Phone: 203-226-5642  
Natl: 800-242-1150  
Fax: 203-226-5322

**Carnow, Conibear & Associates Ltd**  
333 W Wacker Drive No. 1400  
Chicago, IL 60606  
Phone: 312-782-4486  
Natl: 800-359-1979  
Fax: 312-782-5145

**Caron Compactor Co**  
809 Sylvan No. 500  
Modesto, CA 95350  
Phone: 209-578-5814  
Natl: 800-448-8236  
Fax: 209-578-2833

**Carriff Corp Inc**  
2890 Highway 49 North  
Concord, NC 28025  
Phone: 704-786-3917  
Natl: 800-845-5184  
Fax: 704-788-8514



**Carylon Corp**  
2500 W Arthington St  
Chicago, IL 60612-4108  
Phone: 312-666-7700  
Natl: 800-621-4342  
FAX: 312-666-5810  
Cleaning/Flushing Services;  
Contracting Services; Dredging  
Services; Hazardous Waste/Mat  
Treatment, Storage, Disposal;  
Landfills Services; Oil Spill Control  
Equipment/Services; Pipeline  
Cleaning, Repair; Sludge  
Dewatering/Disposal Service;

**Sludge Management**  
SEE AD ON PAGE 66

**Carvo Scientific Instruments Inc**  
422 Humboldt Court  
Sunnyvale, CA 94089  
Phone: 408-745-7400  
Natl: 800-231-0711  
Fax: 408-745-0309



**Cedarapids Inc A Raytheon Company**  
916 16th St Northeast  
Cedar Rapids, IA 52402  
Phone: 319-363-3511  
Fax: 319-399-4871

**Celite Corp**  
PO Box 519  
Lompoc, CA 93438  
Phone: 805-735-7791  
Natl: 800-342-8667  
Fax: 805-735-5699

**Center for Hazardous Materials Research**  
U-PARC 320 William Pitt Way  
Pittsburgh, PA 15147  
Phone: 412-826-5920  
Fax: 412-826-5552

**Chem-Pruf Door Co**  
PO Box 4560  
Brownsville, TX 78523-4560  
Natl: 800-444-6924  
Fax: 210-544-7943

**Chem-Tainer Industries**  
361 Neptune Ave  
West Babylon, NY 11704  
Phone: 516-661-8300  
Natl: 800-645-5607  
Fax: 516-661-8209

**Chem-Tex Corp**  
550 W Ingham Ave  
Trenton, NJ 08638  
Phone: 609-392-6770  
Natl: 800-875-6770  
Fax: 609-392-7506

**ChemCycle Corp**  
129 South St  
Boston, MA 02111  
Phone: 617-451-0922  
Fax: 617-482-3382

**Chemco Mfg Co Inc**  
3175 MacArthur Blvd  
Northbrook, IL 60062  
Natl: 800-323-0401  
Fax: 800-336-7706

**Chemfab Corp**  
701 Daniel Webster Highway  
PO Box 1137  
Merrimack, NH 03054  
Phone: 603-424-9000  
Natl: 800-451-6101  
Fax: 603-424-9012



**Chemical Abstract Services**  
2540 Ottenangy River Road  
Columbus, OH 43201  
Phone: 614-447-3600  
SEE AD ON PAGE 100, 101

**Chemical Information System**  
810 Genealegs Court No. 300  
Towson, MD 21286  
Phone: 410-321-8440  
Natl: 800-247-8737  
Fax: 410-296-0712

**Chemical Lime Co**  
PO Box 121874  
Fort Worth, TX 76121-1874  
Phone: 817-732-8164  
Natl: 800-365-6724  
Fax: 817-732-8144

**Cheminer Inc**  
5870 Poe Ave  
Dayton, OH 45414  
Phone: 513-534-3200  
Fax: 513-454-3379

**Chemtrol Div of Nibco Inc**  
5250 W 78th St  
Indianapolis, IN 46268  
Phone: 317-875-9477  
Natl: 800-343-5455  
Fax: 317-875-9533

**Central Environmental Inc**  
700 E 46th Ave

Anchorage, AK 99503  
Phone: 907-561-0125  
Fax: 907-561-0178



**Chester Environmental**  
600 Clubhouse Drive  
Moon Township, PA 15108  
Phone: 412-269-5700  
Natl: 800-337-0777  
Fax: 412-269-5749

**Chief Industries**  
PO Box 2078  
Grand Island, NE 68802  
Phone: 308-382-8820  
Fax: 308-389-7448

**Chlorinators Inc**  
4125 N.W. Martin Highway No. 2  
Palm City, FL 34990  
Phone: 407-288-4854  
Natl: 800-327-9761  
Fax: 407-287-3238

**Chlorine Specialties**  
123 Holloway Ave, PO Box 12065  
San Francisco, CA 94112-2329  
Phone: 415-333-4822

**Civacon-Dover Resources**  
PO Box 54807  
Cincinnati, OH 45254-0907  
Phone: 513-528-8816  
Fax: 513-528-7802

**Clamshell Buildings Inc**  
1900 Knoll Drive  
Ventura, CA 93003  
Phone: 805-650-1700  
FAX: 805-650-1733  
SEE AD ON PAGE 27

**Clarkson Co, The**  
650 Spice Islands Drive  
Sparks, NV 89431  
Phone: 702-359-4100  
Fax: 702-359-4306

**Claymax Corp**  
234 Gordon St, PO Box 88  
Fairmount, GA 30139  
Phone: 706-337-5316  
Natl: 800-229-2538  
Fax: 706-337-7334

**Clean Air Engineering**  
500 W Wood St  
Palatine, IL 60067  
Phone: 708-991-3300  
Natl: 800-627-0033  
Fax: 708-991-0036

**Clean Environmental Equipment**  
1133 Seventh St  
Oakland, CA 94607  
Phone: 510-891-1880  
Natl: 800-537-0757  
Fax: 510-444-6789



**Clean Gas Systems Inc**  
160-2 Remington Blvd  
Ronkonkoma, NY 11779  
Phone: 516-467-1600  
Fax: 516-467-1688

**Clean Soil Inc**  
PO Box 3391  
Columbia, SC 29224  
Phone: 803-699-0413  
Fax: 803-699-0413

**Clean Venture/Cycle Chem**  
1160 State St  
Perth Amboy, NJ 08862  
Phone: 908-442-4900  
Natl: 800-347-7672  
Fax: 908-826-9380

**Cleaver-Brooks**  
PO Box 421  
Milwaukee, WI 53201  
Phone: 414-359-0600  
Fax: 414-577-2715



**Clement Industries Inc**  
Route 7 South, PO Box 914  
Minden, LA 71058  
Phone: 318-377-2776  
Natl: 800-562-5948  
Fax: 318-377-8426



**Clements Associates Inc**  
1992 Hunter Ave  
Newton, IA 50208  
Phone: 515-792-8285  
Natl: 800-247-6630  
Fax: 515-792-1361  
Core Sampler; Soil Sampling  
Equipment  
SEE AD ON PAGE 34

**Climatronics Corp**  
140 Wilbur Place  
Bohemia, NY 11716  
Phone: 516-567-7300  
Fax: 516-567-7585

**Coastal Environmental Systems**  
316 Second Ave South  
Seattle, WA 98104  
Phone: 206-682-6048  
Fax: 206-682-5658

**Coastal Leasing Inc**  
179 Sidney St  
Cambridge, MA 02139-4238  
Phone: 617-497-1122  
Fax: 617-497-1188

**Coastwide Environmental Technologies Inc**  
342 Enos Lane  
Watsonville, CA 95076  
Phone: 408-761-5511  
Fax: 408-761-5513

**Cochrane Associates Inc**  
155 Massachusetts Ave  
Boston, MA 02115  
Phone: 617-247-0444  
Natl: 800-487-3266  
Fax: 617-247-2785

**Cole-Parmer Instrument Co**  
7425 N Oak Park Ave  
Oak Park, IL 60714  
Phone: 708-647-7600  
Natl: 800-323-4340  
Fax: 708-647-9660

**College Research Corp (CORECO)**  
N116 W16800 Main St  
PO Box 577  
Germantown, WI 53022  
Phone: 414-255-4700  
Fax: 414-255-5283

**Colloid Environmental Technologies Co**  
1350 W Shure Drive  
Arlington Heights, IL 60004  
Phone: 708-392-5800  
Fax: 708-506-6150



**Colog Inc**  
17301 W Colfax Ave No. 265  
Golden, CO 80465  
Phone: 303-279-0171  
Natl: 800-753-0855  
Fax: 303-279-2730

**Conductivity Instrumentation; Consulting Services; Data Acquisition Equipment; Data Loggers; Density Instrumentation; Equipment Rental; Field Testing Instruments/Services; Flow Instrumentation; Geophysical Instruments; Groundwater Testing & Monitoring Equipment; Instrument Rental; Moisture Instrumentation; Water Quality Instrumentation**  
SEE AD ON PAGE 32

**Concrete Science Industries Co**  
11950 Jollyville Road  
Austin, TX 78720  
Phone: 512-258-5191  
Fax: 512-258-5004

**Columbia Scientific**  
PO Box 203190  
Austin, TX 78720  
Phone: 512-258-5191  
Natl: 800-531-5003  
Fax: 512-258-5004



**Columbian Steel Tank**  
PO Box 2907

Kansas City, KS 66110  
Phone: 913-621-3700  
Fax: 913-621-2145

**Commercial Dexterity Ltd**  
Green Acre House  
Wokingham, Berkshire  
England RG115YA  
Bioremediation; Consulting  
Services; Environmental Audits;  
Groundwater Treatment/Services;  
Soil Gas/Groundwater Surveys;  
Soil Sampling Equipment; VOC  
Removal Systems; Wastewater  
Treatment Systems  
SEE AD ON PAGE 64

**Commonwealth Biomonitoring**  
7256 Company Drive  
Indianapolis, IN 46237  
Phone: 317-887-5855  
Fax: 317-887-8641

**Compacting Technologies**  
2417 NW Thurman St  
Portland, OR 97210-2522

**Compliance Management Systems**  
3437 W Seventh St  
Fort Worth, TX 76107  
Natl: 800-700-8737  
Fax: 214-438-0186

**Compliance Mgmt Assoc**  
PO Box 5087  
Suffolk, VA 23435  
Phone: 804-484-8754

**Compu Chem Environmental Corp**  
3306 Chapel Hill, Nelson Highway  
Research Triangle Park, NC  
27709-4998  
Phone: 919-486-1600  
Natl: 800-833-5097  
Fax: 919-406-1666

**Computational Mechanic**  
25 Bridge St  
Billerica, MA 01821-1023  
Phone: 508-567-5841  
Fax: 508-567-7582



**Computer All 1-800-844-1000**  
**Computer All**  
6000 E Dawson Blvd  
Atlanta, GA 30093  
Phone: 404-840-1002  
Natl: 800-844-1400  
Fax: 404-840-7020  
Computer Databases; Computer  
Devices; Computer Software,  
Management; Computer Software,  
Regulatory; Computer Software,  
Training; Hazardous Material  
Handling; Hazardous  
Material/Waste; Hazardous  
Waste/Mat Treatment, Storage,  
Disposal; Hazardous Waste  
Transportation; Labeling;  
Management Services; Portable  
Computers; Waste Minimization  
SEE AD ON PAGE 120

**Con-Tect**  
39 Spruce St  
East Longmeadow, MA 01028  
Phone: 413-525-1198  
Natl: 800-634-8165  
Fax: 413-525-8227

**Conservatek Industries Inc**  
498 Loop 368 East  
Conroe, TX 77301  
Phone: 409-539-1747  
Natl: 800-880-3663  
Fax: 409-539-5355

**Conspar Bridge Systems**  
PO Box 20286  
Dayton, OH 45420-0266  
Natl: 800-526-3999  
Fax: 513-254-8365

**Construction Link Inc, The**  
3394 Sutton Road  
Geneva, NY 14456  
Phone: 315-789-4333  
Natl: 800-448-0741  
Fax: 315-781-0908

**Consulting Environmental Engineering Inc**  
100 Shield St  
West Hartford, CT 06110  
Phone: 203-953-0023  
Fax: 203-953-7407

**Container Testing Laboratory Inc**  
607 Fayette Ave

Mamaroneck, NY 10543  
Phone: 914-381-2600  
Phone: 800-221-5170  
Fax: 914-381-0143

**Containment Corp**  
10889 Portal Drive  
Los Alamitos, CA 90720  
Phone: 714-821-6570  
Natl: 800-235-7421  
Fax: 714-821-9949

**Contech Construction Products Inc**  
1001 Grove St  
Middletown, OH 45044  
Phone: 513-425-5301  
Natl: 800-338-1122  
Fax: 513-425-5993

**Control Electronics Inc**  
Mount View Road  
Morgantown, PA 19543  
Phone: 610-286-7118  
Fax: 610-286-5821

**Control Instruments Corp**  
25 Law Drive  
Fairfield, NJ 07004  
Phone: 201-575-9114  
Fax: 201-575-0013

**Controlotron**  
155 Plant Ave  
Hauppauge, NY 11788  
Phone: 516-231-3600  
Fax: 516-231-3334

**CONVAULT**  
1-800-222-7099

**Convall Inc**  
Spring Road  
Denair, CA 95316  
Phone: 209-632-7571  
Natl: 800-222-7099  
Fax: 209-632-4711  
SEE AD ON PAGE 140

**Converto Mfg Co Inc**  
PO Box 287  
Cambridge City, IN 47327-0287  
Phone: 317-478-3205  
Fax: 317-478-1223

**Conwed Environmental**  
PO Box 357  
Riverside, NJ 08075  
Phone: 609-461-3400  
Natl: 800-366-1180  
Fax: 609-461-5138

**Corbus A Div of CMS Inc**  
236 Line Road  
Kennett Square, PA 19348  
Phone: 610-444-5691  
Natl: 800-524-7096  
Fax: 610-444-6461

**Corporation for Environmental Management**  
36 S Pennsylvania No. 410  
Indianapolis, IN 46204  
Phone: 317-687-8700  
Fax: 317-687-8729

**Cosmos Gas Detection**  
PO Box 70498  
Seattle, WA 98107  
Phone: 206-789-5410  
Fax: 206-789-5414

**COUNTERPOINT PUBLISHING**  
1-800-998-4515

**Counterpoint Publishing**  
84 Sherman St, PO Box 928  
Cambridge, MA 02140  
Natl: 800-998-4515  
Fax: 617-547-9064

**Computer Databases; Computer Software; Management; Computer Software; Regulatory**  
SEE AD ON PAGE 14

**Cover-It Instant Garage All Weather Shelter**  
531 Ella Grasso Blvd  
New Haven, CT 06519  
Phone: 203-781-8010  
Natl: 800-932-9344  
Fax: 203-781-8005

**Covino Environmental Consulting Inc**  
300 Wildwood Ave  
Woburn, MA 01801  
Phone: 617-933-2555  
Fax: 617-932-9402

**Creative Errands Environmental**

**Sample Transporter**  
PO Box 736  
Kemmore, NY 14217  
Phone: 716-773-6960  
Fax: 716-773-5708

**Critical-Vac Filtration Corp (CVAC)**  
701 Hannibal St  
Fulton, NY 13069  
Phone: 315-593-8582  
Natl: 800-543-2822  
Fax: 315-593-7350

**Croll Reynolds Co Inc**  
PO Box 668  
Westfield, OH 07091  
Phone: 908-232-4200  
Fax: 908-232-2146

**Crompton & Knowles Corp Industrial Products Div**  
PO Box 31317  
Charlotte, NC 28233  
Phone: 704-372-5690  
Natl: 800-323-4383

**Cushman Inc**  
PO Box 82409  
Lincoln, NE 68501-2409  
Phone: 402-475-9581  
Natl: 800-728-8580  
Fax: 402-474-8522

**D**

**DCE Inc**  
11301 Electron Drive  
Jeffersonville, IN 40299  
Phone: 502-267-0707  
Natl: 800-767-0702  
Fax: 502-267-3074

**DNV Technica Inc**  
40925 County Center Drive No. 200  
Temecula, CA 92591  
Phone: 909-694-5790  
Fax: 909-694-5799

**Dames & Moore**  
911 Wilshire Blvd No. 700  
Los Angeles, CA 90017  
Phone: 213-683-1560  
Natl: 800-448-1958  
Fax: 213-628-0015

**Dampney Co Inc**  
85 Paris St  
Everett, MA 02149  
Phone: 517-389-2805  
Natl: 800-537-7023  
Fax: 617-389-0484

**Dancer Communications Inc**  
649 South Ave Bldg No. 6  
Secane, PA 19316  
Phone: 610-543-8066  
Fax: 610-543-2151

**Dasibi Environmental Corp**  
506 Paula Ave  
Glendale, CA 91201  
Phone: 818-247-7601  
Fax: 818-247-7614

**Data Industrial Corp**  
11 Industrial Drive, PO Box 740  
Mattapoisett, MA 02739  
Phone: 508-758-6390  
Fax: 508-758-4057

**Datstream Systems Inc**  
1200 Woodruff Road C40  
Greenville, SC 29607  
Phone: 803-297-6775  
Natl: 800-955-6775  
Fax: 803-627-7227

**Datatest Corp**  
6850 Hibbs Lane  
Levittown, PA 19057  
Phone: 215-943-0668  
Fax: 215-547-7973

**Davis Instruments**  
800-368-2516

**Davis Instruments**  
4701 Mt Hope Dr  
Baltimore, MD 21215  
Phone: 410-358-3900  
Natl: 800-368-2516  
FAX: 410-358-0252  
SEE AD ON PAGE 137

**DeMarco MAX VAC Corp**  
674 S County Line Road  
Bensenville, IL 60106  
Phone: 708-766-1119  
Fax: 708-766-1077

**Dean Pump Div Met-Pro Corp**  
6040 Guion Road

Indianapolis, IN 46854  
Phone: 317-293-2930  
Fax: 317-297-7028

**Deeco Inc**  
16717 1/2 E Parkside  
Cerritos, CA 90703  
Phone: 310-404-8304  
Fax: 310-404-9102

**1-800-269-3375**  
DELTA COOLING TOWERS, Inc.

**Delta Cooling Towers Inc**  
PO Box 952  
Fairfield, NJ 07004  
Phone: 201-227-0300  
Natl: 800-289-3358  
Fax: 201-227-0458  
Air Strippers; Cooling Towers; VOC Removal Systems; Wastewater Treatment Systems; Water Conditioning Equipment; Water Purification Systems; Water/Wastewater Treatment Equipment  
SEE AD ON PAGE 62

**Denver Mineral Engineers Inc**  
8122 Southpark Lane No. 110  
Littleton, CO 80120  
Phone: 303-798-4442  
Fax: 303-730-2431

**DESAL**  
DESALINATION SYSTEMS, INC.  
619-746-4995

**Desalination Systems Inc**  
12384 Simpson Way  
Escondido, CA 92079  
Phone: 619-746-4995  
Fax: 619-747-8253  
Desalination Equipment; Reverse Osmosis Equipment; Ultrafiltration Equipment; Wastewater Treatment Systems; Water Purification Systems; Water/Wastewater Treatment Equipment  
SEE AD ON PAGE 163

**Detail Associates Inc**  
300 Grand Ave  
Englewood, NJ 07631  
Phone: 201-565-0708  
Fax: 201-565-4378

**DET TRONICS**  
1-800-765-3473

**Detector Electronics Corp**  
8901 W 110th St  
Minneapolis, MN 55438  
Phone: 612-941-5665  
Natl: 800-765-3473  
Fax: 612-829-8750

**Deslax Corp**  
One Hamden Park Drive  
Hamden, CT 06517  
Phone: 203-288-3501  
Natl: 800-433-9745  
Fax: 203-248-6523

**Diagenex Inc**  
288 Lindbergh Ave  
Livernore, CA 94550  
Phone: 510-606-5600  
Fax: 510-606-5643

**Diagraph Corp**  
3401 Rider Trail South  
St Louis, MO 63045  
Phone: 314-739-1221  
Natl: 800-722-1125  
Fax: 314-770-5748

**Dianachart Inc**  
101 Round Hill Drive  
Rockaway, NJ 07866  
Phone: 201-625-2299  
Fax: 201-625-2449

**Dickson Co, The**  
930 S Westwood Ave  
Addison, IL 60101-4917  
Phone: 708-543-3747  
Natl: 800-323-2448  
Fax: 708-543-0498

**Dieterich Standard**  
A 3000 Industries Company  
303-533-9600

**Dieterich Standard, a Dover Industries Co**  
PO Box 9000  
Boulder, CO 80301  
Phone: 303-533-9600

**Fax: 303-530-7064**  
**Flow Instrumentation; Transmitters**  
SEE AD ON PAGE 64

**Dionex Corp**  
1228 Titan Way, PO Box 3603  
Sunnyvale, CA 94088-3603  
Phone: 408-737-0700  
Fax: 408-739-4398

**Direct Safety Co**  
7815 S 46th St  
Phoenix, AZ 85044  
Phone: 602-968-7009  
Natl: 800-528-7405  
Fax: 602-438-1690

**Discflo Corp**  
1817 John Towers Ave  
El Cajon, CA 92020  
Phone: 619-596-3181  
Fax: 619-449-1990

**Ditch Witch**  
PO Box 66  
Perry, OK 73077  
Phone: 405-336-4402  
Fax: 405-336-5823

**Dival Safety Equipment**  
1721 Niagara St  
Buffalo, NY 14207  
Phone: 716-874-9060  
Natl: 800-343-1354  
Fax: 716-874-4686

**Diversified Well Products Inc**  
800-225-9355

**Diversified Well Products Inc**  
2176 N Pacific St  
Orange, CA 92670  
Phone: 714-457-2283  
Natl: 800-225-9355  
Fax: 714-637-2431  
SEE AD ON PAGE 30

**Dixon Environmental Associates Inc**  
1 Great Valley Parkway No. 6  
Malvern, PA 19355  
Phone: 610-644-6111  
Fax: 610-644-5720

**Dodge/Reliance Electric**  
PO Box 499  
Greenville, SC 29602  
Midland, VA 22002  
Phone: 703-439-8911  
Natl: 800-547-4045  
Fax: 703-439-1232

**Dow Chemical Co, The**  
1691 N Swede Road  
Midland, MI 48674  
Phone: 517-636-1000  
Natl: 800-447-4369  
Fax: 517-636-1630

**Drexelbrook Engineering Co**  
205 Keith Valley Road  
Horsham, PA 19044  
Phone: 215-674-1234  
Fax: 215-674-2731

**Dual Div Met-Pro Corp**  
1550 Industrial  
Owosso, MI 48867  
Phone: 517-725-8184  
Fax: 517-725-8188

**Ducon Environmental Systems Inc**  
110 Bi-County Blvd  
Farmingdale, NY 11735  
Phone: 516-420-4900  
Natl: 800-394-4990  
Fax: 516-420-4985

**Duriron Co Inc, The**  
PO Box 1145  
Dayton, OH 45401  
Phone: 513-226-4200  
Fax: 513-226-4221

**DÜRR**  
313-459-6800

**Durr Industries Inc**  
46360 Plymouth Road  
Plymouth, MI 48170  
Phone: 313-459-6800  
Fax: 313-459-5837

**Dustvent Inc**  
100 W Fay St  
Addison, IL 60101  
Phone: 708-543-9007  
Natl: 800-553-3687  
Fax: 708-543-1407

**Dwyer Instruments Inc**  
PO Box 373  
Michigan City, IN 46361

Phone: 219-879-8000  
Fax: 219-872-9057

**Dyna-Fid Inc**  
131 Wallace Ave No. 2  
Downington, PA 19335  
Phone: 610-873-7824  
Fax: 610-873-9506

**Dynasincs Inc**  
3535 SW Corporate Parkway  
Palm City, FL 34990  
Phone: 407-286-9933  
Natl: 800-535-3669  
Fax: 407-287-0011

**YNECOL**  
313-571-7141

**Dynecol Inc**  
6520 Georgia St  
Detroit, MI 48211  
Phone: 313-571-7141  
Fax: 313-571-7190  
SEE AD ON PAGE 30

**E**

**E & G Rotron - Industrial Div**  
North St  
Saugerties, NY 12477  
Phone: 914-246-3400  
Fax: 914-246-3802

**E S E Bioscience**  
3208 Spring Forest Road  
Raleigh, NC 27604-2822  
Phone: 919-872-9686  
Fax: 919-872-6747

**E S Industries**  
70 S Route 7  
Berlin, NJ 08009  
Phone: 609-753-8400  
Natl: 800-356-6140  
Fax: 609-753-8484

**EA Engineering, Science & Technology Inc**  
11019 McCormick Road  
Hunt Valley, MD 21031  
Phone: 410-584-7000  
Fax: 410-771-1625

**EASI-SET Industries**  
PO Box 300  
Midland, VA 22002  
Phone: 703-439-8911  
Natl: 800-547-4045  
Fax: 703-439-1232

**EBAA Iron Sales Inc**  
PO Box 857  
Eastland, TX 76448  
Phone: 817-629-1731  
Natl: 800-433-1716  
Fax: 817-629-8931

**EBW Inc**  
28214 McCracken Ave  
Muskegon, MI 49441  
Phone: 616-755-1671  
Natl: 800-475-5151  
Fax: 616-755-7201

**ECOSTAT Inc**  
PO Box 237  
Highland City, FL 33846  
Phone: 813-646-5187  
Fax: 813-644-3739

**ECS**  
1-800-637-6161

**ECS Underwriting Inc**  
520 Eagleview Road  
Exton, PA 19341-0636  
Phone: 610-458-0570  
Natl: 800-327-4144  
Fax: 610-458-8667  
Insurance  
SEE AD ON PAGE 143

**EDAC Inc**  
100 Aniline Ave  
Holliston, MA 01942  
Phone: 616-393-9300  
Fax: 616-393-0588

**EET Inc**  
4710 Bellaire Ave No. 300  
Bellaire, TX 77401  
Phone: 713-862-0727  
Fax: 713-662-2322

**EFA Technologies Inc**  
1611 20th St  
Sacramento, CA 95814  
Phone: 916-443-8842  
Fax: 916-443-3759

**EG & G Marine Instruments**  
217 Middlesex Turnpike  
Burlington, MA 01803  
Phone: 617-270-9100  
Fax: 617-270-9724

**EIMCO Process Equipment Co**  
PO Box 300  
Salt Lake City, UT 84110-0300  
Phone: 801-526-2000  
Fax: 801-526-2425

**EIT**  
251 Welsh Pool Road  
Exton, PA 19341  
Phone: 610-363-5450  
Natl: 800-634-4046  
Fax: 610-363-0167



**EKTO Mfg Corp**  
Eagle Drive Sanford Industrial  
Estates  
Sanford, ME 04073  
Phone: 207-324-4427  
Fax: 207-324-4667

**ELB & Associates**  
605 Eastown Drive  
Chapel Hill, NC 27514  
Phone: 919-967-2228  
Natl: 800-334-5478  
Fax: 919-493-2263

**ELE International Inc/Soiltest  
Products Div**  
85 Albrecht Drive, PO Box 8004  
Lake Bluff, IL 60044  
Phone: 708-295-9400  
Natl: 800-323-1242  
Fax: 708-295-9414



**EM Science**  
480 Democrat Road  
Gibbstown, NJ 08027  
Natl: 800-222-0342  
Fax: 609-423-4388  
SEE AD ON PAGE 18

**EMI Inc Eastern-Cleveland Mixers**  
Heritage Park Road, PO Box 912  
Clinton, CT 06413  
Phone: 203-669-1199  
Natl: 800-243-1188  
Fax: 203-669-7461

**EMPE Inc**  
220 Athens Way No. 410  
Nashville, TN 37228  
Phone: 615-255-9300  
Fax: 615-255-9345

**ENMET Corp**  
PO Box 979  
Ann Arbor, MI 48106  
Phone: 313-761-1270  
Fax: 313-761-3220

**ENPAC Corp**  
121 Industrial Parkway  
Chardon, OH 44024  
Phone: 216-286-9222  
Fax: 216-286-9299

**ENSCI Environmental Inc**  
1108 Old Thomsville Road  
High Point, NC 27280  
Phone: 910-883-7505  
Natl: 800-241-9890  
Fax: 910-882-7958

**EPD Technology Corp**  
14 Hayes St  
Emsford, NY 10523  
Phone: 914-592-1234  
Natl: 800-892-8926  
Fax: 914-347-2181

**EPG Companies Inc**  
PO Box 224  
Maple Grove, MN 55369  
Phone: 612-424-2613  
Natl: 800-443-7426  
Fax: 612-424-7426

**ERM Group, The**  
855 Springdale Drive  
Exton, PA 19341  
Natl: 800-544-3117  
Fax: 610-524-7335

**ERM-South Inc**  
9501 Princess Palm Ave No. 100  
Tampa, FL 33619  
Phone: 813-822-8727

Fax: 813-621-8504  
**ERS Services**  
PO Box 1123  
Pottstown, PA 19464  
Phone: 610-970-7033  
Fax: 610-970-7218

**ES Industries**  
701 S Route 73  
Berlin, NJ 08009  
Phone: 609-753-8400  
Natl: 800-356-6140  
Fax: 609-753-8484

**ESCA Tech Inc**  
1752 W Silver Spring Drive  
Milwaukee, WI 53209  
Phone: 414-351-5404  
Fax: 414-351-5406

**Eager Beaver Recycling  
Equipment**  
409S Southgate Court  
Mickleton, NJ 08056  
Phone: 609-423-0200  
Natl: 800-257-8163  
Fax: 609-423-0999

**Eagle Compressors**  
PO Box 458, 6122 Hunt Road  
Pleasant Garden, NC 27313  
Phone: 910-674-3621  
Fax: 910-674-2955

**Eagle-Picher/Env Science &  
Technology**  
200 B J Tunnell Blvd East  
Miami, OK 74354  
Phone: 918-540-1507  
Natl: 800-331-7425  
Fax: 918-540-1604

**Earth & Atmospheric Sciences Inc**  
PO Box 986  
Dayton, OH 45401-0986  
Phone: 513-859-1316  
Natl: 800-543-9930  
Fax: 513-859-7930

**Earth Resource Mapping**  
4370 La Jolla Village Drive No. 900  
San Diego, CA 92122  
Phone: 619-558-4709  
Fax: 619-558-2657

**East Mfg Corp**  
PO Box 277  
Randolph, OH 44265  
Phone: 216-325-9921  
Fax: 216-325-7851

**Eastern Technical Associates**  
PO Box 58495  
Raleigh, NC 27658-8495  
Phone: 919-878-3188  
Fax: 919-872-5199

**Eckenfelder**  
227 French Landing Drive  
Nashville, TN 37228  
Phone: 615-255-2288  
Fax: 615-256-8332

**Eco Tek Laboratory Services Inc**  
3342 Intl Park Drive SE  
Atlanta, GA 30316  
Phone: 404-244-0827  
Fax: 404-243-9355



**Eco Waste Solutions**  
296 Northshore Blvd West  
Burlington, Ohio, CN L7T 1A4  
Phone: 905-385-7546  
Natl: 800-368-7546  
Fax: 905-385-7839  
SEE AD ON PAGE 55

**EcoAnalysis Inc**  
221 E Matliffa St No. A  
Ojai, CA 93023  
Phone: 805-646-1461  
Natl: 800-646-1461  
Fax: 805-646-4141

**Ecom America Ltd**  
3075 Breckinridge Blvd No. 420  
Duluth, GA 30136  
Phone: 404-806-0220  
Fax: 404-806-0120

**Ecotech Inc**  
8018 One Calais Ave No. B  
Baton Rouge, LA 70809-3404  
Phone: 504-767-8018  
Fax: 504-767-1173

**Edwards & Cromwell Mfg Inc**  
4301 Jeffrey Drive  
Baton Rouge, LA 70816  
Phone: 504-292-3377

Fax: 504-292-7519  
**Edwards Engineering**  
101 Alexander Ave  
Pompton Plains, NJ 07444-0487  
Phone: 201-835-2800  
Natl: 800-526-5201  
Fax: 201-835-3222



**Elcor Systems Inc**  
910 National Ave  
Addison, IL 60101  
Phone: 708-543-2214  
Natl: 800-645-5325  
Fax: 708-543-2014

**Air Strippers; Groundwater  
Reclamation; Groundwater  
Treatment/Services; Hazardous  
Waste Equipment; Landfills;  
Leachate Treatment; Oil/Water  
Separation; Packaged Treatment  
Plants; Pump Controllers;  
Pumping Stations/Systems;  
Pumps (sludge, wastewater,  
groundwater, misc.); Remediation;  
Separators; Wastewater Treatment  
Systems; Water/Wastewater  
Treatment Equipment**  
SEE AD ON PAGE 52

**ElectroSynthesis Co**  
PO Box 430  
East Amherst, NY 14051-0430  
Phone: 716-684-0513  
Fax: 716-684-0511



**Elgin Sweeper Co**  
1300 W Bartlett Road  
Elgin, IL 60121  
Phone: 708-741-5370  
Fax: 708-742-3035

**Ellicott Engineering Inc**  
1601 Bush St  
Baltimore, MD 21230  
Phone: 410-837-7900  
Fax: 410-539-6104

**Emergency Film Group**  
225 Water St  
Plymouth, MA 02360  
Phone: 508-746-0466  
Natl: 800-842-0999  
Fax: 508-746-5220

**Emerc EMC Fiberglass Casing &  
Well Screens**  
11029 Signal Hill Drive  
Austin, TX 78737  
Phone: 512-288-6091  
Fax: 512-288-6099

**EnoWaste Intl Corp**  
PO Box 1490  
Bellingham, WA 98227  
Phone: 206-738-1254  
Fax: 206-738-1376

**Enron Services Inc**  
10820 E 45th No. 100  
Tulsa, OK 74146-3814  
Phone: 918-665-7693  
Fax: 918-665-7232



**Energy Efficiency Systems Inc**  
1300 Shames Drive  
Westbury, NY 11590  
Phone: 516-997-2100  
Natl: 800-695-3637  
FAX: 516-997-2129  
**Air Analyzers; Air Emissions  
Monitoring Equipment; Air Quality  
Instrumentation; Analytical  
Instruments; Analytical  
Instruments, Air; Carbon Monoxide  
Detectors; Hydrogen Sulfide  
Detectors; Monitoring Systems,  
Air; Nitrogen Oxide Detectors;  
Stack Emission Monitors; Stack  
Emission Testing; Sulfur Dioxide**  
SEE AD ON PAGE 11

**Energy Hydraulics**  
PO Box 458  
Monticello, IA 52310-0458

**Engelhard Corp**  
101 Wood Ave  
Iselin, NJ 08830  
Phone: 908-205-5000  
Natl: 800-631-9505

Fax: 908-205-6711  
**Engineering Software**  
PO Box 8128  
Truckee, CA 96162  
Phone: 916-582-1525  
Fax: 916-582-8579

**Enreo Inc**  
PO Box 9838  
Amarillo, TX 79105  
Phone: 806-379-6424  
Fax: 806-379-7319

**Ensys Environmental Products Inc**  
PO Box 14083  
Research Triangle Park, NC 27709  
Phone: 919-941-5509  
Natl: 800-242-7472  
Fax: 919-941-5519

**Entech Instruments**  
2265 Ward Ave No. A  
Simi Valley, CA 93065  
Phone: 805-527-5939  
Fax: 805-527-5687

**Entoleter Inc**  
251 Walton St  
Hartford, CT 06517  
Phone: 203-787-3575  
Fax: 203-787-1492

**Entropy Inc**  
PO Box 12291  
Research Triangle Park, NC 27709  
Phone: 919-871-3550  
Natl: 800-486-3550  
Fax: 919-878-8442

**Envires Corp**  
12103 Linden Lane  
Bowling, MD 21715-2350  
Phone: 301-464-9202  
Fax: 301-464-6284

**Envirex**  
1901 S Prairie Ave  
Waukesha, WI 53186  
Phone: 414-521-8467  
Fax: 414-547-4120

**Envrite Corp**  
620 W Germantown Pike No. 250  
Plymouth Meeting, PA 19462  
Phone: 610-828-8655  
Natl: 800-366-9922  
Fax: 610-828-8406

**Enviro Care**  
5614 W Grand Ave  
Chicago, IL 60639-2911  
Phone: 312-745-7773  
Fax: 312-745-8383

**Enviro Filtration**  
4719 Rossevelt St  
Gary, IN 46408  
Natl: 800-368-4763  
Fax: 312-734-8884

**Enviro-Sciences Inc**  
111 Howard Blvd No. 108  
Mount Arlington, NJ 07856  
Phone: 201-398-8183  
Natl: 800-516-4848  
Fax: 201-398-8037

**EnviroBase Systems Inc**  
PO Box 308  
Parker, CO 80134-0308  
Phone: 303-941-6315  
Natl: 800-283-7313  
Fax: 303-840-0851

**Envirogen Inc**  
4100 Quakerbridge Road  
Lawrenceville, NJ 08648  
Phone: 609-936-9300  
Fax: 609-936-9221

**Envirotronics Inc**  
1201 Commerce St  
Port of Albany  
Albany, NY 12202  
Phone: 518-838-8336  
Fax: 518-838-8336

**Envirox**  
PO Box 197  
Wayne, PA 18877  
Phone: 610-975-9790  
Fax: 610-975-9793

**Environics**  
165 River Road  
Willington, CT 06279-1636  
Phone: 203-429-0077  
Fax: 203-429-5040

**Environmental Basics Co**  
PO Box 453  
Shillington, PA 19607  
Phone: 610-796-9102  
Fax: 610-796-1453

**Environmental Claims**

**Administrators**  
600 Eaglewood Road  
Exton, PA 19341  
Phone: 610-458-7445  
Fax: 610-458-7448

**Environmental Compaction Inc**  
1280 Lakeview Road  
West Bend, WI 53095  
Phone: 414-692-2450  
Fax: 414-692-2450

**Environmental Compliance  
Systems Corp**  
13015 Middletown Industrial Blvd  
Louisville, KY 40223  
Phone: 502-244-4545  
Natl: 800-347-9677  
Fax: 502-244-4554

**Environmental Container Corp**  
PO Box 161  
Datsfield, WI 53018-0161  
Natl: 800-729-7137  
Fax: 414-646-2908

**Environmental Data Resources Inc**  
3530 Post Road  
Southport, CT 06490  
Phone: 203-434-9200  
Fax: 800-231-6802

**Environmental Education  
Enterprises Inc**  
2764 Sawbury Blvd  
Columbus, OH 43235  
Phone: 614-792-9000  
Natl: 800-792-0005  
Fax: 614-792-0006

**Environmental Energy Services Inc**  
PO Box 871, 19 Seth Low Mtn Road  
Ridgfield, CT 06877  
Phone: 203-433-0302  
Fax: 203-438-5729

**Environmental Fuel Systems Inc**  
PO Box 1899  
Bandera, TX 78003  
Phone: 210-796-7767  
Natl: 800-375-7747  
Fax: 210-796-7484

**Environmental Health &  
Engineering Inc**  
255 Washington St  
Newtown, MA 02158  
Phone: 617-964-8550  
Natl: 800-525-5343  
Fax: 617-964-8556

**Environmental Industrial  
Resources**  
PO Box 4819  
Evanston, IL 47724-0819  
Phone: 812-424-8900  
Natl: 800-441-3470  
Fax: 812-424-8970

**Environmental Monitor  
Systems Inc**  
10222 Hammary No. 250  
Houston, TX 77043  
Phone: 713-467-3514  
Fax: 713-467-3514

**Environmental Products &  
Services Inc**  
99 Marginal St  
Chelsea, MA 02150  
Phone: 617-884-8884  
Fax: 617-884-2174

**Environmental Products &  
Services Inc**  
PO Box 315  
Synapse, NY 13209-0315  
Phone: 315-471-0503  
Natl: 800-843-8265  
Fax: 315-475-8920

**Environmental Products &  
Services Inc**  
11485-11th St  
Albany, NY 12202  
Phone: 518-465-4000  
Fax: 518-465-5722

**Environmental Protection Inc**  
9939 US 131 South NE, PO Box 333  
Upper Darby, PA 19082  
Phone: 610-587-9108  
Natl: 800-345-4637  
Fax: 610-587-8020

**Environmental Protection Systems**  
160 Long Lane No. D  
Upper Darby, PA 19082  
Phone: 610-352-7420  
Fax: 610-352-7268

**Environmental Recovery  
Resources Inc**  
300 Adams St No. B  
Bedford Hills, NY 10507  
Phone: 914-241-2827



Natl: 800-795-3489  
Fax: 914-242-7346

**Environmental Resource Associates**

5540 Marshall St  
Anvada, CO 80002  
Phone: 303-431-8544  
Natl: 800-372-0122  
Fax: 303-421-0159

**Environmental Resource Center**

101 Center Pointe Drive  
Cary, NC 27513-5706  
Phone: 919-469-1585  
Natl: 800-537-2372  
Fax: 919-469-4137

**Environmental Restoration**

800-944-5508

**Environmental Restoration Systems Inc**

9 Dogwood Lane, PO Box 510  
Middletown, PA 17057-0510  
Phone: 717-944-5508  
Natl: 800-944-5515  
Fax: 717-944-4551

**Aeration Systems; Air Strippers; Aquifer Restoration; Blowers; Communication Equipment; Compressors; Computer Control; Data Acquisition Equipment; Equipment Rental; Groundwater Reclamation; Groundwater Treatment/Systems; Monitoring Systems, Water; Motor Controllers; Oil Skimmers; Oil Spill Control Equipment/Services; Oil/Water Separation; Packaged Treatment Plants; Passive Hydrocarbon Recovery System; Process Control Instrumentation; Pump Controllers; Pumps (sludge, wastewater, groundwater, misc.); Remediation; Rental Services; Spill Control Equipment/Products/Services; Telemetry Systems; Training Services/Equipment; VOC Removal Systems; Water/Wastewater Treatment Equipment**  
SEE AD ON PAGE 18

**Environmental Services & Products Inc**

903 Sheehy Drive  
Horsesham, PA 19048  
Phone: 215-674-8660  
Natl: 800-523-6702  
Fax: 215-674-3328

**Environmental Standards Inc**

1140 Valley Forge Road, PO Box 911  
Worcester, PA 16092-0911  
Phone: 610-935-5577  
Fax: 610-935-5583

**Environmental Techniques**

PO Box 1113  
Pottstown, PA 19464  
Phone: 610-327-8207  
Fax: 610-970-7218

**Environmental Technologies Group**

1400 Taylor Ave, PO Box 9840  
Baltimore, MD 21284-9840  
Phone: 410-321-5156  
Natl: 800-836-4598  
Fax: 410-321-5325  
134

**Enviropack**  
800-423-8188

**Enviropack**

3645 NW 67th St  
Miami, FL 33147  
Phone: 305-693-4680  
Natl: 800-423-8188  
Fax: 305-836-1296

**Enviroplan Inc**

3 Becker Farm Road  
Roseland, NJ 07068  
Phone: 201-994-2300  
Fax: 201-994-5100

**Envirovision Group Inc, The**

331 Route 9W  
Congers, NY 10920  
Phone: 914-268-6660  
Fax: 914-268-2065

**Epic Inc**

150 Nassau St  
New York, NY 10038-1516  
Phone: 212-349-2478  
Fax: 212-406-2508

**EPOLEON CORPORATION OF AMERICA**  
1-800-EPOLEON

**Epoelon Corp of America**

19160 S Van Ness  
Torrence, CA 90501-1101  
Phone: 310-782-0191  
**Chemicals; Landfill Services; Odor Control Equipment; Sludge Management; Wastewater Treatment Systems**  
SEE AD ON PAGE 24

**Equinox International**

8703 Hayshed Lane No. 14  
Columbia, MD 21045  
Phone: 410-909-0274  
Fax: 410-740-2052

**Ergo-Medical Inc**

100 N Curry Pike  
Bloomington, IN 47404  
Phone: 812-331-0596  
Natl: 800-424-4417  
Fax: 812-332-2367

**Esion Thermaplastics**

PO Box 240894  
Charlotte, NC 28224  
Phone: 704-889-2431  
Natl: 800-578-7681  
Fax: 704-889-2810

**Everest Interscience Inc**

1625 W Ina Road No. 123  
Tucson, AZ 85704  
Phone: 602-797-0927  
Natl: 800-422-4342  
Fax: 602-797-0938

**Exothermics-Eclipse Inc**

5040 Enterprise Blvd  
Toledo, OH 43612-3880  
Phone: 419-729-9726  
Natl: 800-662-3966  
Fax: 419-729-9705

**Etexch Instruments**

335 Bear Hill Road  
Waltham, MA 02154  
Phone: 617-890-7440  
Fax: 617-890-7864

**F**

**FBA Environmental Inc**

107 N Main St No. 200  
Marion, OH 43302-3029  
Phone: 614-383-2187  
Fax: 614-382-1420

**FERtech Environmental Inc**

630 N Morley No. 107, PO Box 918  
Moberly, MO 65270  
Phone: 816-263-1000  
Fax: 816-263-9304

**FFM - Fluid Metering Inc**

28 Orchard St, PO Box 179  
Oyster Bay, NY 11771  
Phone: 516-922-6050  
Natl: 800-223-3388  
Fax: 516-624-8261

**FABRIC BUILDING SYSTEMS, INC.**  
813-351-1020

**Fabric Building Systems Inc**

4919 80th Ave Circle East  
Sarasota, FL 34243  
Phone: 813-351-6996  
Fax: 813-351-1020  
**Enclosures, Structural; Hazardous Waste/Mat Treatment, Storage, Disposal; Shelters**  
SEE AD ON PAGE 32

**Fabrico** 800-621-8546

**Fabrico Environmental Liners Inc**

4222 Plushki Road  
Chicago, IL 60632  
Phone: 312-890-5350  
Natl: 800-621-8546  
Fax: 312-890-4669

**Fairbanks Morse Pump Corp**

PO Box 6999  
Kansas City, KS 66106-0999  
Phone: 913-371-5000  
Fax: 913-371-2272

**Falmouth Products**

530 Thomas Landers Rd  
PO Box 541  
Falmouth, MA 02541

Phone: 508-548-6686  
Fax: 508-548-8144

**Fast Search Corp**

1000 Shelard Parkway No. 200  
Minneapolis, MN 55426  
Natl: 800-232-4590  
Fax: 612-595-0229

**Feco Engineered Systems Inc**

5855 Grant Ave  
Cleveland, OH 44105  
Phone: 216-441-2400  
Fax: 216-441-6529

**Ferrick Construction Co Inc**

811 Ivy Hill Road  
Philadelphia, PA 19150  
Phone: 215-836-7470  
Fax: 215-885-5520

**Ferro Corp, Bedford Chemical Div**

7050 Krick Road  
Walton Hills, OH 44146  
Phone: 216-641-8580  
Fax: 216-439-7636

**Ferro Corp, Electronic & Specialty Gases Glass Corp**

4150 E 56th St, PO Box 6550  
Cleveland, OH 44101  
Phone: 216-641-8580  
Fax: 216-641-8857

**Ferro Corp, Frit Div**

4150 E 56th St, PO Box 6550  
Cleveland, OH 44101  
Phone: 216-641-8580  
Fax: 216-641-7049

**Ferro Corp, Grant Chemical Div**

PO Box 263  
Baton Rouge, LA 70821  
Phone: 504-654-6801  
Fax: 504-654-3268

**Ferro Corp, Liquid Coatings & Dispersion Div/Indiana**

1301 N Flora St  
Plymouth, IN 46563  
Phone: 219-935-5131  
Natl: 800-424-2009  
Fax: 219-935-5278

**Ferro Corp, Specialty Ceramics Div/Cesco Plant**

416 Maple Ave, PO Box 151  
Crooksville, OH 43731  
Phone: 614-982-2050  
Natl: 800-245-8225  
Fax: 614-982-9396

**Ferro Corp, Specialty Ceramics Div/Filtron Plant**

603 W Commercial St, PO Box 389  
620 Harvey Ave, PO 14445  
Phone: 716-586-8770  
Natl: 800-633-2143  
Fax: 716-586-7154

**Ferro Corp, Specialty Ceramics Div/Louthan Plant**

2000 Harvery Ave  
East Liverpool, OH 43920  
Phone: 216-385-1605  
Natl: 800-245-9885  
Fax: 216-385-8268

**Fibercast Co**

PO Box 968  
Sand Springs, OK 74063-0968  
Phone: 918-245-6651  
Natl: 800-331-4406  
Fax: 800-365-7473

**Fiberlock Technologies Inc**

830 Putnam Ave  
Cambridge, MA 02139  
Phone: 617-876-8020  
Natl: 800-342-3755  
Fax: 617-547-6934

**Fike Corp**

704 SW 10th St  
Blue Springs, MO 64015-4286  
Phone: 816-229-3405  
Fax: 816-228-9277

**Filtron Plant Corp**

603 W Commercial St  
East Rochester, NY 14445  
Phone: 716-586-8770  
Natl: 800-633-2143  
Fax: 716-586-7154

**Finch Manufacturing Co Inc**

540 Montgomery Ave  
West Pittsford, PA 16843  
Phone: 707-655-2277  
Fax: 707-655-6758

**Finish Thompson Inc**

921 Greengarden Road  
Erle, PA 16501-1525  
Phone: 814-455-4478

Natl: 800-934-9384  
Fax: 800-455-8518

**Finn Corp**

9281 LeSaint Drive  
Fairfield, OH 45014  
Phone: 513-874-2818  
Natl: 800-543-7166  
Fax: 513-874-2914

**Finnigan/Trematics**

2215 Grand Ave Parkway  
Austin, TX 78728-3812  
Phone: 512-251-1551  
Natl: 800-876-6711  
Fax: 512-251-1597

**Fisher Scientific Safety Products Div**

711 Forbes Ave  
Pittsburgh, PA 15219  
Natl: 800-766-7000  
Fax: 800-926-1166

**Flexaust Co**

11 Chestnut St  
Amesbury, MA 01913  
Phone: 508-388-9700  
Natl: 800-343-0428  
Fax: 508-388-2711

**Fliomatic Corp**

PO Box 100, Mill Lane  
North Housick, NY 12133-0100  
Phone: 518-686-7381  
Natl: 800-833-2040  
Fax: 518-686-5670

**Fluid Components Intl**

1755 La Costa Meadows Drive  
San Marcos, CA 92069-5197  
Phone: 619-744-6950  
Natl: 800-854-1990  
Fax: 619-736-6250

**Fluid Controls Inc**

3435 Stanwood Blvd NE  
Huntsville, AL 35811  
Phone: 205-851-6000  
Natl: 800-482-0860  
Fax: 205-852-6005

**Fluid Data Inc**

1201 N Velasco  
Angleton, TX 77515  
Phone: 409-849-2344  
Fax: 409-849-2166

**Fluid Systems**

1245 Corporate Blvd No. 300  
Aurora, IL 60504  
Natl: 800-346-9107  
Fax: 708-898-1179

**Fluidyne Corp**

2815 W First St  
Cedar Falls, IA 50613  
Phone: 319-266-9667  
Fax: 319-277-6034

**FLUOR DANIEL**  
714-975-6480

**Fluor Daniel Environmental Services Inc**

3333 Michelson Drive  
Irvine, CA 92730  
Phone: 714-975-8884  
Fax: 714-975-6545

**Fluorware**

102 Jonathan Blvd N  
Chaska, MN 55318  
Phone: 612-448-8181  
Fax: 612-368-8022

**Foppe Thelen Group Inc**

11415 Century Blvd  
Cincinnati, OH 45246  
Phone: 513-671-8144  
Natl: 800-486-8144  
Fax: 513-671-8150

**Forrer Supply Co Inc**

N117 W18388 Fulton Drive  
Germantown, WI 53022-2400  
Phone: 414-255-3030  
Fax: 414-255-4064

**Foster Wheeler Environmental Corp**

1290 Wall St West  
Lynchurst, NJ 07071  
Phone: 201-842-7000  
Fax: 201-842-7025

**Foth & Van Dyke**

2737 S Ridge Road  
Green Bay, WI 54307  
Phone: 414-497-2500  
Fax: 414-497-8516

**FOXBORO®**  
1-800-521-0451

**Foxboro Co, The**

33 Commercial St M/S H01-H  
Foxboro, MA 02035-2099  
Phone: 508-378-5472  
Fax: 508-378-5505  
**Air Analyzers; Air Emission Monitoring Equipment; Air Quality Instrumentation; Air Samplers; Analysis, Gas Chromatography; Analysis, Liquid Chromatography; Analysis, Soil, Water, Air; Analytical Instruments; Analytical Instruments, Air; Analytical Instruments, Hazardous Materials; Carbon Dioxide Detectors; Carbon Monoxide Detectors; Data Loggers; Gas Chromatographs; Gas Detectors; Groundwater Testing & Monitoring Equipment; Hydrocarbon Detectors; Indoor Air Quality; Industrial Hygiene; Leak Detectors; Soil Gas/Groundwater Surveys; Soil Sampling Equipment; Sulfur Dioxide; Toxic Gas Detectors; Tracer Products; Underground Storage Tank Equipment; Underground Tank Leak Monitors**  
SEE AD ON PAGE 46

**Framco Environmental Technology**

1856 Apex Road  
Sarasota, FL 34240  
Phone: 813-377-3600  
Fax: 813-377-6900

**Free Flow Inc**

PO Box 4067  
Omaha, NE 68104-0067  
Phone: 402-397-8910  
Fax: 402-397-8487

**Frontier Technology Inc**

609 N Eastern Ave  
Allenton, IL 62400  
Phone: 616-673-9464  
Natl: 800-307-2187  
Fax: 616-673-9629

**Fybco Division Met-Pro Corp**

700 Emilen Way  
Telford, PA 16969  
Phone: 215-723-8155  
Fax: 215-723-2197

**G**

**G A Huber Co**

6407 El Paso Ct  
Carlsbad, CA 92009  
Phone: 619-438-1903  
Fax: 619-438-4329

**G E Co**

326 West Oaks Office Park  
Albany, NY 12203-5965  
Phone: 518-869-5555  
Natl: 800-626-2004  
Fax: 518-869-2828

**G O Environmental Inc**

1235 NW 163th St  
Miami, FL 33169  
Phone: 305-621-2882  
Fax: 305-621-1710

**GES**  
800-220-3068

**GES (Groundwater & Environmental Services Inc)**

PO Box 1750, 1340 Campus Parkway  
Wall, NJ 07719  
Phone: 908-919-1646  
Natl: 800-220-3068  
Fax: 908-919-1678  
**Environmental Engineering; Environmental Site Assessment; Groundwater Testing & Monitoring Equipment; Groundwater Treatment/Services; Remediation; Remediation, Insitu; Remediation Services**  
SEE AD ON PAGE 33

**GTEL Environmental Laboratories**

Meadowbrook Industrial Park  
Milford, NH 03065  
Phone: 603-672-4835  
Fax: 603-673-8105

**Galaxy Environmental Corp**

600 Louis Drive No. 202  
Warminster, PA 18974

**COMPANY PROFILES**

Phone: 215-672-8176  
Fax: 215-672-8708

**Galbreath Inc**  
Rosser Drive, PO Box 220  
Winamac, IN 46996  
Phone: 219-946-6631  
Fax: 219-946-4579

**Galsion Corp**  
8601 Kirkville Road  
East Syracuse, NY 13057  
Phone: 315-432-0506  
Natl: 800-950-0506  
Fax: 315-437-0509

**Gannett Fleming Inc**  
PO Box 67100  
Harrisburg, PA 17106  
Phone: 717-763-7211  
Natl: 800-233-1055  
Fax: 717-763-7323

**Gardner Denver Machinery Inc**  
1800 Gardner Expressway  
Quincy, IL 62301  
Phone: 217-222-5400  
Fax: 217-224-7814

**GASBACH**  
150  
**510-745-1275**

**Gas Tech Inc**  
8407 Central Ave  
Newark, CA 94560  
Phone: 510-745-1275

**Gascoyne Laboratories Inc**  
2100 Van Deman St  
Baltimore, MD 21224-6697  
Phone: 410-633-1800  
Natl: 800-427-2696  
Fax: 410-633-6553

**Gast Manufacturing Corp**  
PO Box 97, 2550 Meadowbrook Ave  
Benton Harbor, MI 49023-0097  
Phone: 616-926-6171  
Fax: 616-926-1817

**gator pump, inc.**  
1-800-735-9811

**Gator Pump Inc**  
302 Corigan  
Brownwood, TX 76801  
Phone: 915-643-3502  
Natl: 800-735-9811  
Fax: 915-643-5760

**Gelok Intl Corp**  
Pine Lake Industrial Park  
Dunbridge, OH 43414  
Phone: 419-352-1482  
Fax: 419-352-8340

**Gems Sensors Div**  
One Cowles Street  
Plainville, CT 06062  
Phone: 203-747-3000  
Natl: 800-321-6070  
Fax: 203-747-4244

**General Analysis Corp**  
140 Water St, Box 528  
South Norwalk, CT 06856  
Phone: 203-852-8999  
Natl: 800-327-2460  
Fax: 203-838-1551

**General Carbon Corp**  
33 Patterson St  
Paterson, NJ 07651-1015  
Phone: 201-523-2223  
Fax: 201-523-1494

**General Kinematics Corp**  
777 Lake Zurich Road  
Barrington, IL 60011-3197  
Phone: 708-381-2240  
Fax: 708-381-1376

**General Monitors**  
26776 Simpatica Circle  
Lake Forest, CA 92530-8128  
Phone: 714-581-4464  
Fax: 714-581-1151

**General Research Corp**  
1900 Gallows Road  
Vienna, VA 22182  
Phone: 703-506-5166  
Natl: 800-834-5917  
Fax: 703-760-8747

**General Rubber Corp**  
11 Empire Blvd  
South Hackensack, NJ 07066  
Natl: 800-233-6294  
Fax: 201-641-4710



**General Rubber Corp/Flexible Valve Corp**  
11 Empire Blvd  
South Hackensack, NJ 07066-1890  
Phone: 201-641-4700  
Natl: 800-233-6294  
Fax: 201-641-4710

**General Sciences Corp**  
6100 Chevy Chase Drive No. 200  
Laurel, MD 20707-2929  
Phone: 301-953-2700  
Fax: 301-953-1213

**Genium Publishing Corp**  
1 Genium Plaza  
Schenectady, NY 12304-1894

**Geo-Con Inc**  
4075 Monroeville Blvd No. 400  
Monroeville, PA 15146  
Phone: 412-856-7700  
Fax: 412-373-3357

**Groundwater Treatment/Services; Hazardous Material/Waste; Hazardous Waste/Mat Treatment, Storage, Disposal; Landfills, Service, Liners; Remediation, Insitu; Remediation, Services; Sludge Solidification; Slurry Cut-off Walls; Wastewater Treatment Systems**  
**SEE AD ON PAGE 54**

**Geo-Technology Associates Inc**  
42 N Main St No. 200  
Bel Air, MD 21014  
Phone: 410-879-8446  
Fax: 410-893-3437

**GeoPure Continental Systems & Services**  
2300 NW 71st Place  
Gainesville, FL 32653-1699  
Phone: 904-376-7833  
Natl: 800-342-1103  
Fax: 904-373-7660

**GeoSynTec Consultants**  
One Park Place, 621 NW 53rd St  
Boca Raton, FL 33487  
Phone: 407-995-0900  
Natl: 800-825-4436  
Fax: 407-995-0925

**Geogard Inc**  
536 Orient St  
Medina, NY 14103  
Phone: 716-798-6937  
Natl: 800-645-7654  
Fax: 716-798-0147

**Geophysical Survey Systems Inc**  
13 Klein Drive  
North Salem, NH 03073-0097  
Phone: 603-893-1109  
Natl: 800-324-3011  
Fax: 603-899-3984

**George Fischer Inc**  
2882 Dow Ave  
Tustin, CA 92680-7285  
Phone: 714-731-8800  
Natl: 800-854-4090  
Fax: 714-731-6201

**Georgia Steel & Chemical**  
10810 Guilford Road No. 104  
Annapolis Junction, MD 20701-1118  
Phone: 301-317-5502  
Natl: 800-296-0313  
Fax: 301-470-6313

**Geotrans Inc**  
46050 Manekin Plaza No. 100  
Sterling, VA 22170-6519  
Phone: 703-444-5426  
Fax: 703-444-1685

**Geraghty & Miller Inc**  
A Heidemic Co  
1099 18th St No. 2100  
Denver, CO 80202  
Phone: 303-294-1200  
Fax: 303-294-1239

**Gilliam Instrument Corp**  
35 Fairfield Place  
West Caldwell, NJ 07066  
Phone: 201-808-3355  
Natl: 800-344-5426  
Fax: 201-808-6680

**Glen Mills Inc**  
395 Alwood Road  
Clifton, NJ 07012  
Phone: 201-777-0777  
Fax: 201-777-0070

**Glenro Inc**  
39 McBride Ave  
Paterson, NJ 07651-1715  
Phone: 201-279-5900  
Natl: 800-922-0106  
Fax: 201-279-9103

**Global Environmental Inc**  
5311 Spring Canyon Trail  
Rapid City, SD 57702  
Phone: 605-342-5311  
Fax: 605-342-8058

**Global Water**  
Infrastructure • Treatment • Service  
**916-863-0804**

**Global Water**  
10725 Fair Oaks Blvd  
Fair Oaks, CA 95628  
Phone: 916-863-0804  
Fax: 916-863-0315

**Godwin Pumps of America Inc**  
One Floodgate Road  
Bridgeport, NJ 08027  
Phone: 609-467-3636  
Fax: 609-467-5676

**Gojo Industries Inc**  
PO Box 991  
Akron, OH 44309-0991  
Phone: 216-920-8100  
Natl: 800-321-9647  
Fax: 216-920-8119

**Golden Software Inc**  
809 14th St  
Golden, CO 80401  
Phone: 303-279-1021  
Natl: 800-373-1021  
Fax: 303-279-0909

**Goodway Technologies Corp**  
420 West Ave  
Stamford, CT 06902-6384  
Phone: 203-359-4708  
Natl: 800-333-7467  
Fax: 203-359-9601

**GOODWAY U.S.A.**  
14006 Arose Hwy, Dallas, TX, CA 97106  
**1-800-349-7546**

**Goodway USA**  
14506 Arrow Highway  
Baldwin Park, CA 91706  
Phone: 818-856-3388  
Natl: 800-349-7546  
Fax: 818-856-3378  
**Safety Equipment & Products**  
**SEE AD ON PAGE 41**

**GR**  
419-755-1011

**Gorman-Rupp Co., The**  
305 Bowman St  
Mansfield, OH 44903-1600  
Phone: 419-755-1011  
Fax: 419-755-1251

**Grace Industries Inc**  
PO Box 167  
De Pere, WI 54115  
Phone: 412-962-9231  
Natl: 800-969-6933  
Fax: 412-962-3611

**Grace TEC Systems**  
830 Prosper Road  
De Pere, WI 54115  
Phone: 414-336-5715  
Natl: 800-873-8458  
Fax: 414-339-2784

**Grace Thermal & Emission Control System**  
PO Box 1203  
Baltimore, MD 21203  
Phone: 410-659-9580  
Natl: 800-638-3844  
Fax: 410-659-9023

**GRAY**  
414-259-1500

**Graef Anhalt Schloemer**  
345 N 95th St  
Milwaukee, WI 53226-4441  
Phone: 414-259-1500  
Fax: 414-259-0037

**Graham Mfg Co Inc**  
PO Box 719  
Batavia, NY 14021-0719  
Phone: 716-343-2216  
Fax: 716-343-1097

**Gran-Tenesco Resources Inc**  
2314 North American St  
Philadelphia, PA 19133-3307  
Phone: 215-739-4045  
Fax: 215-739-0434

**Graseby Specac Inc**  
301 Commerce Drive  
Fairfield, CT 06430  
Rapid City, SD 57702  
Natl: 800-447-2558  
Fax: 203-384-1524

**GrassRoots Marketing Inc**  
PO Box 939  
Bronxville, NY 10708  
Phone: 914-337-5959  
Fax: 914-271-8588

**Graying Industries**  
1008 Branch Drive  
Alpha, GA 30201-5688  
Phone: 404-751-9095  
Natl: 800-635-1551  
Fax: 404-751-3710

**Great Lakes Environmental Inc**  
463 Vista  
Addison, IL 60101  
Phone: 708-543-9444  
Fax: 708-543-1169

**Green Earth Technologies Corp**  
81 Caldwell Drive  
Cincinnati, OH 45216  
Phone: 513-679-4010  
Fax: 513-679-4071

**Griffin Environmental Co Inc**  
7066 Interstate Island Road  
Syracuse, NY 13209  
Natl: 800-451-5300  
Fax: 315-451-2338

**Griswold Controls**  
2803 Barranca Parkway  
Irvine, CA 92714  
Phone: 714-559-6008  
Fax: 714-559-6088

**Grossman, Walter B Assoc**  
4-59 Ivy Lane  
Fair Lawn, NJ 07410-1652

**Groundwater Service & Supply Inc**  
2701 SE Convenience Blvd No. 6  
Ankney, IA 50021  
Phone: 515-964-0304  
Fax: 515-964-1226

**Groundwater Technician Services Inc**  
PO Box 281  
Whiting, NJ 08759  
Phone: 908-350-3827  
Fax: 908-650-1517

**Groundwater Technology Inc**  
100 River Ridge Drive  
Norwood, MA 02062  
Phone: 617-769-7600  
Natl: 800-835-0053  
Fax: 617-769-7992

**Group 206 Technologies Inc**  
6705 NW 24th Place  
Gainesville, FL 32606  
Phone: 904-375-6596  
Fax: 904-376-9135

**Grundfos Pumps Corp**  
2555 Clovis Ave  
Clovis, CA 93612  
Natl: 800-333-1366  
Fax: 800-333-1363

**Guardian Industries**  
3201 Ohio St, PO Box 478  
Michigan City, IN 46360  
Phone: 219-874-5248  
Fax: 219-879-6643

**Gulfl States Analytical Inc**  
6310 Rothway St  
Houston, TX 77040  
Phone: 713-690-4444  
Fax: 713-690-5646

**Gurdle Lining Systems Inc**  
19103 Gurdle St  
Houston, TX 77073  
Phone: 713-443-8564  
Natl: 800-435-2008  
Fax: 713-875-6010

**Gurman Container & Supply Corp**  
800 N Third St, PO Box 1071  
Terra Haute, IN 47808  
Phone: 812-232-3413  
Natl: 800-448-7626  
Fax: 812-232-8345

**Guzzler Mfg Inc**  
575 N 37th St  
Birmingham, AL 35222

Phone: 205-591-2477  
Natl: 800-822-8785  
Fax: 205-591-2495

H

**H & H Pump & Dredge**  
16100 Hwy 190 East  
Hemlock, WA 98101  
Phone: 504-345-5351  
Fax: 504-345-0932

**H E S Inc**  
525 Science Drive  
Madison, WI 53711-1060  
Phone: 608-297-4520  
Fax: 608-293-0502

**H F Scientific Inc**  
3170 Metro Parkway  
Fort Myers, FL 33916-7597  
Phone: 813-337-2116  
Natl: 800-798-2116  
Fax: 813-332-7643

**H H Burkitt Project Management Inc**  
2041 S W 58th Ave Skyline Blvd  
Portland, OR 97221-1333  
Phone: 503-297-4520  
Fax: 503-297-4519

**H2 Oil Recovery Equipment Inc**  
PO Box 9028  
Bend, OR 97708  
Phone: 503-382-7070  
Fax: 503-382-2242

**HnS Environmental Inc**  
**512-918-8035**

**HZNS Environmental**  
PO Box 20137  
Austin, TX 78720  
Phone: 512-918-8035

**HDR Engineering Inc**  
8404 Indian Ridge Drive  
Omaha, NE 68114  
Phone: 402-399-1000  
Fax: 402-399-1238

**HEMCO**  
**816-796-2900**

**HEMCO Corp**  
111 North Powell  
Independence, MO 64056  
Phone: 816-796-2900  
Fax: 816-796-3333  
**SEE AD ON PAGE 31**

**HI-Q ENVIRONMENTAL**  
**619-549-2820**

**HI-Q Environmental Products Co**  
7386 Trade St  
San Diego, CA 92121  
Phone: 619-549-2820  
Fax: 619-549-9657  
**Aerosol Detectors; Air Quality Instrumentation; Air Samplers; Air Velocity Meter; Analytical Instruments; Air Filter Accessories; Flow Instrumentation; Radiometer/Radiation Instrumentation; Sampling Systems; Stack Emission Monitors; Stack Emission Testing; Stack Flow Meters**  
**SEE AD ON PAGE 47**

**HNU Systems Inc**  
160 Charleston St  
Newton, MA 02459  
Phone: 617-964-6690  
Natl: 800-724-5600  
Fax: 617-558-0056

**HACH**  
800-227-4224  
**800-227-4224**

**Hach Co**  
PO Box 389  
Loveland, CO 80539  
Phone: 303-669-3050  
Natl: 800-227-4224  
Fax: 303-669-2932

**Haestad Methods**  
37 Brookside Road  
Waterbury, CT 06708  
Phone: 203-755-1666  
Natl: 800-727-6555  
Fax: 203-587-1488

**Haley & Aldrich Inc**  
58 Charles St  
Cambridge, MA 02141  
Phone: 617-492-1606  
Fax: 617-577-8142

**Hamilton Co**  
4971 Gregory Way  
Reno, NV 89502  
Natl: 800-648-5950  
Fax: 702-856-7259

**Harcor Inc**  
PO Box 1047, 401 Olive St  
Findlay, OH 45526  
Natl: 800-242-6267  
Fax: 419-424-8302

**Handar**  
1288 Reamwood  
Sunnyvale, CA 94089-2233  
Phone: 408-734-9640  
Natl: 800-955-7367  
Fax: 408-734-0655

**Hankin Environmental Systems Inc**  
One Harvard Way No. 6, PO Box 935  
Somerville, NJ 08876  
Phone: 908-722-9595  
Fax: 908-722-9514

**Hankison International**  
1000 Philadelphia St  
Canonsburg, PA 15317  
Phone: 412-745-1555  
Fax: 412-745-6040

**Hans Environmental Inc**  
PO Box 201837  
Austin, TX 78720  
Phone: 512-918-8035  
Fax: 512-918-9684

**Harborlite Corp**  
PO Box 100  
Vicksburg, MI 459097  
Phone: 616-649-1352  
Fax: 616-649-3707

**Hart Crowler Inc**  
1910 Fairview Ave East  
Seattle, WA 98102  
Phone: 206-324-9530  
Fax: 206-328-5581

**Hartzell Fan Inc**  
910 S Downing St  
Piqua, OH 45356  
Phone: 513-773-7411  
Natl: 800-336-3267  
Fax: 513-773-8994

**Harwil Corp**  
1548 17th St  
Santa Monica, CA 90406  
Phone: 310-229-2310  
Fax: 310-829-2259

**Hayward Baker Environmental**  
1130 Annapolis Road  
Odenton, MD 21113  
Phone: 410-551-1995  
Fax: 410-551-1994

**HAZ-MAT CONTAINMENT CORPORATION**  
**1-800-943-6510**

**Haz Mat Containment Corp**  
712 Bancroft Road No. 216  
Walnut Creek, CA 94598  
Phone: 510-943-5250  
Natl: 800-943-6510  
Fax: 510-210-1054  
SEE AD ON PAGE 39

**Haz-Stor Co**  
2454 Dempster St  
Des Plaines, IL 60616  
Phone: 708-294-1000  
Natl: 800-998-9250  
Fax: 708-298-9250

**HazWaste Technologies Corp**  
2995 Center Green Court South  
Boulder, CO 80301  
Phone: 303-440-5664  
Fax: 303-440-5731

**Hazco Services Inc**  
2006 Springboro West  
Dayton, OH 45439  
Phone: 513-293-2700  
Natl: 800-332-0435  
Fax: 513-293-9227

**Hazen & Sawyer**  
730 Broadway  
New York, NY 10003  
Phone: 212-777-8400  
Fax: 212-228-8369

**Hazen Research Inc**  
4601 Indiana St

**Golden, CO 80403**  
**Phone: 303-279-4501**  
**SEE AD ON PAGE 140**

**Hazleton Environmental**  
125 Butler Drive  
Hazleton, PA 18201  
Phone: 717-454-7515  
Fax: 717-454-7520

**Hazmat America Inc**  
9 Browning Road  
Arlington, MA 02174-7011  
Phone: 617-646-4564  
Fax: 617-646-4564

**HAZ-SAFE**  
Buildings by Design  
**412-842-2130**

**HazSafe**  
PO Box 606  
Leechburg, PA 15656  
Phone: 412-842-2130  
Fax: 412-845-7834  
**Chemical Storage Buildings;**  
**Enclosures, Structural; Hazardous**  
**Material Handling; Hazardous**  
**Waste/Mat Treatment, Storage,**  
**Disposal; Secondary Containment**  
**SEE AD ON PAGE 43**

**Heart Information Systems Inc**  
1500 Regent St  
Schenectady, NY 12309  
Phone: 518-381-9155  
Natl: 800-572-6501  
Fax: 518-785-3639

**HEATH CONSULTANTS**  
**1-800-432-8487**

**Heath Consultants Inc**  
9030 Monroe Road  
Houston, TX 77061  
Phone: 713-947-9292  
Natl: 800-432-8487  
Fax: 713-947-9422  
**Air Emission Monitoring**  
**Equipment; Air Quality**  
**Instrumentation; Carbon Dioxide**  
**Detectors; Carbon Monoxide**  
**Detectors; Cathodic Protection**  
**Equipment; Combustible Gas**  
**Detector; Consulting Services;**  
**Environmental Audits, Gas**  
**Detector; Hydrocarbon Detectors;**  
**Locators, Pipe/Valve/Cable; Odor**  
**Control Equipment; Oxygen**  
**Detectors; Soil Sampling**  
**Equipment; Training Services/**  
**Equipment; Training Videos;**  
**Underground Storage Tank**  
**Equipment; Underground Tank**  
**Leak Monitors**  
**SEE AD ON PAGE 142**

**Helima**  
118-21 Queens Blvd  
Forest Hills, NY 11375  
Phone: 718-544-9534  
Fax: 718-263-6910

**Heritage Environmental**  
Services Inc  
7901 W Morris St  
Indianapolis, IN 46241  
Phone: 317-243-0811  
Natl: 800-927-0476  
Fax: 317-486-5085

**Hersey & Measurement**  
PO Box 4565  
Spartanburg, SC 29303  
Phone: 803-574-8960  
Natl: 800-945-2102  
Fax: 803-578-7308

**Hersey Products**  
Highway 70, PO Box 128  
Cleveland, NC 27013  
Phone: 704-278-2221  
Natl: 800-323-8584  
Fax: 704-278-9616

**Heyl & Patterson Inc**  
PO Box 36  
Pittsburgh, PA 15230  
Phone: 412-788-6900  
Fax: 412-788-6913

**Hi Vac Corp**  
117 Industry Road  
Manetta, OH 45750  
Phone: 614-374-2306  
Natl: 800-752-2400  
Fax: 614-374-5447

**High Voltage Environmental**  
9562 Doral Blvd  
Miami, FL 33178  
Phone: 305-593-5330

Fax: 305-593-0071

**Highland Tank**  
One Highland Road  
Stoytown, PA 15563  
Phone: 814-893-5701  
Fax: 814-893-6126

**Hid Floor Machine**  
5339 W Lake St  
Chicago, IL 60644-2497  
Phone: 312-379-8558  
Fax: 312-379-1776

**Hill International Inc**  
One Levitt Parkway  
Willingboro, NJ 08046  
Phone: 609-871-5800  
Natl: 800-222-0127  
Fax: 609-871-5714

**Hill Manufacturing Co Inc**  
1500 Jonesboro Road SE  
Atlanta, GA 30315  
Phone: 404-522-8364  
Natl: 800-445-5123  
Fax: 404-522-8367

**Hitchi Maxco Ltd**  
1630 Albritton Drive  
Kennesaw, GA 30144  
Phone: 404-424-9350  
Natl: 800-241-8209  
Fax: 404-424-9145

**Hitachi Scientific Instruments**  
755 Ravenscroft Drive  
Mountain View, CA 94043  
Phone: 415-969-1100  
Fax: 415-961-7259

**Holophane Lighting Inc**  
250 E Broad St No. 1400  
Columbus, OH 43215  
Phone: 614-345-9631  
Fax: 614-349-4426

**HORIBA 1-800-446-7422**

**Horiba Instruments Inc**  
17671 Armstrong Ave  
Irvine, CA 92714  
Phone: 714-250-4811  
Natl: 800-446-7422  
Fax: 714-250-0924  
**Air Analyzers; Air Emission**  
**Monitoring Equipment; Air**  
**Emissions Testing; Analytical**  
**Instruments; Analytical**  
**Instruments, Air; Analytical**  
**Instruments, Wastewater;**  
**Analytical Instruments, Water;**  
**Carbon Dioxide Detectors; Carbon**  
**Monoxide Detectors; Conductivity**  
**Instrumentation; Dissolved**  
**Oxygen Detectors; Gas Detectors;**  
**Groundwater Testing & Monitoring**  
**Equipment; Hydrocarbon**  
**Detectors; Laboratory**  
**Equipment/Supplies; Meters;**  
**Monitoring Systems, Air;**  
**Monitoring Systems, Water;**  
**Oil/Water Monitors; ORP**  
**Instrumentation; Particle**  
**Detectors; Particle Sizing**  
**Instruments; pH Instrumentation;**  
**Process Control Instrumentation;**  
**Soil Sampling Equipment; Solvent**  
**Recovery Systems; Stack**  
**Emission Monitors; Sulfur Oxide**  
**Detectors; Test Equipment, misc.;**  
**Water Quality Instrumentation**  
**SEE AD ON PAGE 44**

**Horizontal Technologies Inc**  
PO Box 150820  
Cape Coral, FL 33915  
Phone: 813-995-8777  
Natl: 800-989-1128  
Fax: 813-995-8485

**Horner Creative Products Inc**  
211 Morton St  
Bay City, MI 48706  
Phone: 517-893-3360  
Natl: 800-443-0711  
Fax: 517-893-1227

**Hubbell, Roth & Clark Inc**  
PO Box 824  
Bloomfield Hills, MI 48303-0824  
Phone: 810-338-9241  
Fax: 810-338-2592

**Hudson Industries**  
2235 E Enterprise Parkway  
Windsburg, OH 44087-2347  
Phone: 216-487-0668  
Natl: 800-487-9668  
Fax: 216-487-0811

**Hull Corp Environmental**

**Products Div**  
3535 Davisville Road  
Hatboro, PA 19040  
Phone: 215-672-7800  
Fax: 215-672-7807

**Hunter Inc, Environmental Science**  
PO Box 264, 10 Lewis St  
Lincoln, MA 01773  
Natl: 617-259-0800

**Huntingdon Engineering & Environmental Inc**  
140 Telegraph Road  
Middleport, NY 14105  
Phone: 716-735-3400  
Natl: 800-377-7344  
Fax: 716-735-7056

**Hybco Corp**  
29850 N Highway 41  
Lake Bluff, IL 60044  
Phone: 708-473-3700  
Fax: 708-473-0477

**Hyde Products Inc**  
28045 Ranney Parkway  
Cleveland, OH 44145  
Phone: 216-871-4885  
Fax: 216-871-1143

**Hydro Group**  
1011 Route 22 West  
Bridgewater, NJ 08807  
Phone: 908-704-8880  
Natl: 800-331-0249  
Fax: 908-704-9522

**Hydro-Terra Inc**  
5513 Twin Knolls Road No. 218  
Columbia, MD 21045  
Phone: 301-596-3160

**HYDROLAB**  
**1-800-949-3766**

**Hydrolab Corp**  
PO Box 50116  
Austin, TX 78763-0116  
Phone: 512-255-9841  
Natl: 800-949-3766  
Fax: 512-255-3106  
**SEE AD ON PAGE 22**

**ILC Dover Inc**  
PO Box 266  
Frederica, DE 19946  
Phone: 302-335-3411  
Natl: 800-631-9567  
Fax: 302-335-0762

**IHS**  
Regulatory Products  
**1-800-320-4555**

**IHS Regulatory Products**  
Attn: G343, PO Box 1154  
Englewood, CO 80150-9918  
Phone: 303-267-1559  
Natl: 800-320-4555  
FAX: 303-267-1366  
**SEE AD ON PAGE 25**

**IMS Inc**  
15630 S Keeler, PO Box 2987  
Olathe, KS 66062  
Phone: 913-829-2900  
Natl: 800-800-4010  
Fax: 913-829-2909

**IPEC Industries**  
PO Box 1607  
Vashon, WA 98070  
Phone: 206-292-8198  
Natl: 800-663-8409  
Fax: 604-929-7839

**ISTA Engine Systems Corp**  
415 Hope Ave  
Roselle, NJ 07203  
Phone: 908-241-8880  
Fax: 908-241-7288

**ITT A-C Pump**  
1150 Tennessee Ave  
Cincinnati, OH 45229  
Phone: 513-482-2500  
Fax: 513-482-2569

**Ibox Technologies**  
550 Main St No. G  
Placerville, CA 95667  
Phone: 916-621-3342  
Fax: 916-621-2004

**In-Situ Inc**  
PO Box 1, 210 S Third St  
Laramie, WY 82070  
Phone: 307-742-8213

Fax: 307-721-7598

**Industrial Filter & Pump Mfg Co**  
5900 Ogden Ave  
Cicero, IL 60650-3888  
Phone: 708-656-7800  
Fax: 708-656-7806

**Industrial Scientific Corp**  
1001 Oakdale Road  
Oakdale, PA 15071  
Phone: 412-788-4353  
Natl: 800-338-3287  
Fax: 412-788-8353

**Infiltrator Systems Inc**  
4 Business Park Road, PO Box 768  
Old Saybrook, CT 06475  
Phone: 203-388-6639  
Natl: 800-221-4436  
Fax: 203-388-6810

**Inflatable Abatement Systems Inc**  
PO Box 507, 2 Industrial Drive  
East Millinocket, ME 04430  
Phone: 207-746-9551  
Natl: 800-962-2565  
Fax: 207-746-5795

**Inn-Nova-Tech Inc**  
260 W Main St No. 102  
Hendersonville, TN 37075  
Phone: 615-264-0033  
Fax: 615-264-0070

**Innovative Sensors Inc**  
4745 S. Riverside St  
Anaheim, CA 92807-1993  
Phone: 714-779-8781  
Natl: 800-835-5474  
Fax: 714-779-9315

**Inorganic Ventures Inc**  
195 Lehigh Ave No. 4  
Lakewood, NJ 08753  
Phone: 908-901-1900  
Natl: 800-669-6799  
Fax: 908-901-1903

**Insitec Inc**  
2110 Omega Road No. D  
San Ramon, CA 94583  
Phone: 510-837-1330  
Natl: 800-995-9902  
Fax: 510-837-3864

**Instrumark International**  
485 Sinclair Frontage  
Milpitas, CA 95035  
Phone: 408-262-0717  
Fax: 408-262-3610

**Instruments Direct Inc**  
3535 Corp Parkway  
Palm City, FL 34980  
Phone: 408-287-3355  
Fax: 407-286-0015

**Intec Controls Corp**  
55 West St  
Walpole, MA 02081  
Phone: 508-660-1221  
Fax: 508-660-2374

**Integra Plastics Inc**  
500 12th St Southeast  
Madison, SD 57042  
Phone: 605-256-2666  
Natl: 800-578-5257  
Fax: 605-256-2629

**Integrach Corp**  
Huntsville, AL 35894-0001  
Phone: 205-730-2000  
Natl: 800-345-4856

**Integrated Chemistries Inc**  
1970 Oakcrest Ave No. 215  
St Paul, MN 55113  
Phone: 612-636-2380  
Fax: 612-636-3106

**Integrated Software Design Inc**  
117 Forbes Blvd  
Mansfield, MA 02048  
Phone: 508-339-4928  
Natl: 800-600-2242  
Fax: 508-339-2257

**Intek Corp/Rent-A-Lyzer**  
1170 Rockley Road  
Houston, TX 77099-3555  
Phone: 713-498-5855  
Natl: 800-323-6527  
Fax: 713-498-2134

**International Engineers Inc**  
1776 S Naperville Road No. 102  
Wheaton, IL 60187  
Phone: 708-260-0200  
Fax: 708-260-0797

**International Protective Coatings Corp**  
725 Carol Ave

COMPANY PROFILES

Oakhurst, NJ 07755  
Phone: 908-531-3867  
Natl: 800-334-8796  
Fax: 908-531-5192

**International Recycling Limited**  
55 Garwood  
Fair Lawn, NJ 07410  
Phone: 201-703-0070  
Fax: 201-703-9717

**International Safety Instruments**  
922 Hurricane Shoals Road  
Lawrenceville, GA 30243  
Phone: 404-962-2552  
Natl: 800-235-7677  
Fax: 404-963-2797

**International Sensor Technology**  
3 Whatey  
Irvine, CA 92718  
Phone: 714-452-9000  
Fax: 714-452-9009

**International Technology Corp**  
23456 Hawthorne Blvd  
Torrance, CA 90505-4738  
Phone: 310-378-9933  
Fax: 310-791-2587



**INERVO**  
Serving Specialties Specialists  
1-800-433-8487

**Intervac**  
125 Rawson Road  
Victor, NY 14564  
Phone: 716-924-7080  
Natl: 800-433-8487  
Fax: 716-924-5697

**Intl Hazmat Storage Div of Intl Cold Storage Co Inc**  
215 E 13th St  
Andover, KS 67002  
Phone: 316-733-1385  
Natl: 800-835-0004  
Fax: 316-733-2434

**Invalco Inc**  
401 S Adams  
Hutchinson, KS 67501  
Phone: 316-665-6612  
Natl: 800-468-2526  
Fax: 316-669-2242

**Inventron Inc**  
30927 Schoolcraft Road  
Livonia, MI 48150  
Phone: 313-513-7700  
Fax: 313-513-7705

**Ionics Inc**  
85 Grove St  
Watertown, MA 02172  
Phone: 617-926-2500  
Natl: 800-446-6427  
Fax: 617-926-4304

**Iso Inc Environmental Div**  
531 Westgate Blvd  
Lincoln, NE 68528  
Phone: 402-474-2233  
Natl: 800-228-4373  
Fax: 402-474-6685

**J + W Scientific**  
91 Blue Ravine Road  
Folsom, CA 95630  
Phone: 916-985-7888  
Natl: 916-985-1101

**J J Keller & Associates Inc**  
3003 W Breezewood Lane  
PO Box 368  
Neenah, WI 54957-0368  
Phone: 414-722-2848  
Natl: 800-327-6868  
Fax: 414-727-7516

**J L A Engineering Inc**  
1335 Dublin Road No.211D  
Columbus, OH 43215  
Phone: 614-488-3033  
Fax: 614-488-0054

**J V Mfg Inc/Cram-A-Lot**  
PO Box 229  
Springdale, AR 72765  
Phone: 501-751-7320  
Natl: 800-678-7320  
Fax: 501-751-7774

**JBI Spray Booth Systems**  
801 Norway Road  
Osseo, IL 54758  
Phone: 715-597-3168  
Natl: 800-848-8738  
Fax: 715-597-2193

**JM Clipper Corp**

PO Drawer 2340  
Nacogdoches, TX 75963  
Phone: 409-560-8900  
Natl: 800-233-9900  
Fax: 409-560-8998

**JPS Elastomerics Corp**  
395 Pleasant St  
Northampton, MA 01060  
Phone: 413-882-1072  
Fax: 413-584-3051

**JT Baker Chemical Inc**  
222 Red School Lane  
Phillipsburg, NJ 08865-2200  
Phone: 908-659-2151  
Fax: 908-659-9316

**JWC Environmental**  
16802 Aston St. No. 200  
Irvine, CA 92714  
Phone: 714-833-3888  
Natl: 800-632-2277  
Fax: 714-833-8658

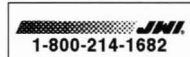

**1-800-214-1682**

**JWI**  
2155 112th Ave  
Holland, MI 49506  
Phone: 616-772-9011  
Fax: 616-772-4516

**Jaac Corp**  
550 Pinelawn Road  
Fort Washington, PA 19034-2682  
Phone: 215-643-5466  
Natl: 800-292-2510  
Fax: 215-643-2772

**Jackson, R L Consulting**  
108 N Church St  
Snow Hill, MD 21863-1202  
Phone: 410-632-0300  
Fax: 410-632-3023

**Jaeger Products Inc**  
611 Peach Leaf  
Houston, TX 77039  
Phone: 713-449-9500  
Natl: 800-678-2345  
Fax: 713-449-9400



**310-444-3325**

**Jardine Insurance Brokers LA Inc**  
801 S Figueroa St. No. 700  
Los Angeles, CA 90017  
Phone: 213-599-4104  
Fax: 213-599-4258  
**SEE AD ON PAGE 44**

**Jerman Waterworks Supply**  
275 Railroad Place  
Hackensack, NJ 07601  
Natl: 800-654-3723  
Fax: 201-487-3953

**Jet Inc**  
750 Alpha Drive  
Cleveland, OH 44143  
Phone: 216-461-2000

**John Crane Inc**  
6400 W Oakton St  
Morton Grove, IL 60053  
Phone: 708-967-2400  
Natl: 800-732-5464  
Fax: 708-967-3915

**Johns Hopkins University Press**  
Hamden Station  
Baltimore, MD 21211  
Phone: 410-516-6900  
Natl: 800-437-5487  
Fax: 410-516-6998



**Johnston Matthay**  
610-971-3100

**Johnson Matthay Env**  
60 E Swansford  
Wayne, PA 19087-1880  
Phone: 610-971-3100  
Fax: 610-293-1284

**Joseph Marketing**  
203 Tilden Drive  
East Syracuse, NY 13057-1629  
Phone: 315-437-0217  
Fax: 315-437-0487

**Justrite Mfg Co/Div of Federal Signal Corp**  
2454 Dempster St  
Des Plaines, IL 60016  
Phone: 708-298-9250

Natl: 800-796-9250  
Fax: 708-298-3429



**K & B Design Inc**  
3131 Disney Ave  
Cincinnati, OH 45209-5011

**KDF Fluid Treatment Inc**  
1500 KDF Drive, PO Box 425  
Three Rivers, MI 49093-0425  
Phone: 616-273-3300  
Natl: 800-437-2745  
Fax: 616-273-4400

**Kappler**  
115 Grimes Drive  
Guntersville, AL 35976  
Phone: 205-505-4000  
Natl: 800-633-2410  
Fax: 205-582-2706

**Kay Industries Inc**  
604 N Hill St  
South Bend, IN 46617  
Natl: 800-348-5257  
Fax: 219-289-5932

**Key Instruments Inc**  
15 DeAngelo Drive  
Bedford, MA 01730  
Phone: 617-275-0300  
Natl: 800-343-4624  
Fax: 617-275-9024

**Keating Environmental Management Inc**  
7 Great Valley Parkway  
Malvern, PA 19355  
Phone: 610-296-3800  
Fax: 610-251-2165

**Keco R & D Inc**  
10034 Clay Road  
Houston, TX 77080  
Phone: 713-690-4425  
Fax: 713-690-2728

**Keithley-Metrayah**  
404 Myles Standish Blvd  
Tauton, MA 02780-1092  
Phone: 508-880-3000  
Natl: 800-348-0033  
Fax: 508-880-0179

**Kelair Products Inc**  
2222 C Pierce Drive  
Spring Grove, IL 60081  
Phone: 815-675-2728  
Fax: 815-675-6324

**Kennedy/Jenks Consultants**  
303 Second St 10th Floor  
San Francisco, CA 94107  
Phone: 415-243-2150  
Fax: 415-896-0999

**Kewaunee Scientific Corp**  
PO Box 1842  
Stateside, NC 28687-1842  
Phone: 704-873-7202  
Fax: 800-932-3296

**Keystone Filter Div Met-Pro Corp**  
2385 N Penn Road  
Hatfield, PA 19440  
Phone: 215-822-1963  
Natl: 800-822-1963  
Fax: 215-997-1839

**Kin-Tek**  
504 Laurel St  
LaMarque, TX 77568  
Phone: 409-936-3627  
Natl: 800-326-3627  
Fax: 409-938-3710

**Kinane Engineering**  
10218 Snow Iris Way  
Sandy, UT 84092  
Phone: 708-892-7440

**Kipp & Zonen**  
390 Central Ave  
Bohemia, NY 11716-3147  
Phone: 516-589-2885  
Natl: 800-645-1025  
Fax: 516-589-2068

**Koch Engineering Co Inc**  
4111 E 37th St North  
Wichita, KS 67208-0127  
Phone: 316-832-5110  
Natl: 800-835-0089  
Fax: 316-832-6843

**Komline Sanderson**  
12 Holland Ave  
Peapack, NJ 07977

**Krebs Engineers**  
1205 Chrysler Drive  
Menlo Park, CA 94025

Phone: 415-325-0751  
Fax: 415-326-7048



**L Robert Kimball & Associates**  
PO Box 1000, 615 W Highland Ave  
Ebensburg, PA 15531  
Phone: 814-472-7700  
Natl: 800-407-5256  
Fax: 814-472-7712

**LEXICON Environmental Associates Inc**  
790 E Market St No. 270  
West Chester, PA 19382-4806  
Phone: 610-344-3380  
Fax: 610-344-3388

**LINC Quantum Analytics**  
363 Vintage Park Drive  
Foster City, CA 94404  
Phone: 415-312-0900  
Natl: 800-992-4199  
Fax: 415-312-0313

**La-Man Corp**  
PO Box 467, 7450  
S Homestead Drive  
Hamilton, IN 46742  
Phone: 219-488-3511  
Natl: 800-348-2463  
Fax: 219-488-3409

**LaBounty Manufacturing Div of Stanley Hydraulic Tools**  
100 State Road 2  
Two Harbors, MN 55616  
Phone: 218-834-2123  
Fax: 218-834-3879

**Lab Safety Supply**  
PO Box 1368  
Janesville, WI 53547-1368  
Phone: 608-754-2345  
Natl: 800-356-0783  
Fax: 608-754-1806

**Lab-Line Instruments Inc**  
15th & Bloomingdale Ave  
Melrose Park, IL 60160  
Phone: 708-450-2600  
Natl: 800-522-5463  
Fax: 708-450-0943

**Labcon Corp**  
8811 Prospect Ave  
Kansas City, MO 64132-2696  
Phone: 816-333-8811  
Natl: 800-821-5528  
Fax: 816-363-0130

**Labelmaster**  
6724 N Lincoln Road  
Columbi, IL 60646  
Phone: 312-478-0900  
Natl: 800-621-5808  
Fax: 312-478-6054

**Lakeside Equipment Corp**  
102 E Orion Ave  
Bartlett, IL 60103  
Phone: 708-837-5640  
Fax: 708-837-5647

**Lamson Corp**  
PO Box 4857  
1022 E. 9th Street  
Syracuse, NY 15221  
Phone: 315-433-5513  
Natl: 800-543-7736  
Fax: 315-433-5451



**Lancaster Laboratories**  
Where Quality is a Science  
717-656-2301

**Lancaster Laboratories Inc**  
2425 New Holland Pike  
Lancaster, PA 17601-5994  
Phone: 717-656-2301  
Fax: 717-656-2621

**Air Emissions Testing; Analysis, Atomic Absorption; Analysis, Electron Microscopy; Analysis, Gas Chromatography; Analysis, Gas Chromatography/Mass Spectrometry; Analysis, Liquid Chromatography; Analysis, Soil, Water, Air; Analytical/Research Services; Bioassay; Indoor Air Quality; Industrial Hygiene; Laboratory Services/Testing; PCB Testing; Stack Emission Testing; TCLP**  
**SEE AD ON PAGE 7**

**Landa Inc**  
13705 NE Airport Way  
Portland, OR 97230-1099  
Phone: 503-255-5980  
Natl: 800-645-2632  
Fax: 800-535-9164

**Landauer Inc**  
2 Science Road  
Glenwood, IL 60425  
Phone: 708-755-7000  
Fax: 708-755-7016

**Larox Inc**  
314 Chatsworth Woods Drive  
Columbia, MD 21046  
Phone: 410-381-3314  
Fax: 410-381-4490

**Leapfrog Technologies**  
1408 Eleventh Ave  
Altona, PA 16601  
Phone: 814-949-2600  
Natl: 800-443-7647  
Fax: 800-872-3764

**Lechler Inc**  
445 Kautz Road  
St Charles, IL 60174  
Phone: 708-377-6611  
Natl: 800-777-2926  
Fax: 708-377-6657

**Leggible Sign Inc**  
2221 Nimitz Road  
Rockford, IL 61111-3997  
Phone: 815-654-0100  
Natl: 800-435-4177  
Fax: 815-654-9679

**Leslie Mfg Inc**  
1207 1800 N Road  
Lawrence, KS 66049  
Phone: 913-842-1943

**Liebert Corp**  
1050 Dearborn Drive  
Columbus, OH 43229  
Phone: 614-888-0246  
Natl: 800-877-9222  
Fax: 614-841-6022

**Limitrque**  
5114 Woodall Road  
Lynchburg, VA 24506

**Lincoln Automotive**  
One Lincoln Ave  
St Louis, MO 63120  
Phone: 314-679-4408  
Natl: 800-625-3268  
Fax: 314-679-4433

**Lindberg A General Signal Co**  
304 Hart St  
Watertown, WI 53094  
Phone: 414-261-7000  
Natl: 800-873-4468  
Fax: 414-261-0925

**Lindmark Engineering Inc**  
1700 Lincoln Ave  
San Fernando, CA 91340  
Phone: 818-365-1170  
Natl: 800-886-1170  
Fax: 818-365-0296

**Liquid Carbon**  
102 E Horn Ave  
Oak Brook, IL 60521-2216  
Phone: 708-572-7500



**LITCO FIT HOG**  
Sludge Test  
1-800-243-1406

**Liquid Waste Technology Inc**  
422 Main St, PO Box 250  
Somerset, WI 54025  
Phone: 715-247-3322  
Natl: 800-243-1406  
Fax: 715-247-3924  
**Agitators; Dredges; Dredging Services; Floats/Pontoons; Land Application Equipment; Land Application Systems; Mixers; Oil Skimmers; Pumps (sludge, wastewater, groundwater, misc.); Sewage/Sludge Disposal Equipment/Services; Sludge Management; Water/Wastewater Treatment Equipment**  
**SEE AD ON PAGE 35**

**Litton**  
PO Box 4588  
Davenport, IA 52808  
Phone: 319-383-6000  
Fax: 319-383-6323

**Lockwood Greene Engineers Inc**  
PO Box 491  
Spartanburg, SC 29304  
Phone: 803-578-2000  
Natl: 800-845-3302  
Fax: 803-599-0436



**1-800-COMPLY1**  
**Logical Technology Inc**  
 613 N Executive Drive  
 Peoria, IL 61614-4868  
 Phone: 309-689-2900  
 Fax: 309-689-2900  
 SEE AD ON PAGE 138



**Longyear**  
 PO Box 1959  
 Stone Mountain, GA 30086  
 Phone: 404-469-2720  
**SEE AD ON PAGE 61**

**Luft Instruments Inc**  
 3 Hillside Road, PO Box 214  
 Lincoln, MA 01773  
 Phone: 617-259-9215  
 Fax: 617-259-9215

**Lycro Manufacturing Inc**  
 115 Commercial Drive  
 Columbus, WI 53925  
 Phone: 414-823-4152  
 Fax: 414-823-3780



**M-D Pneumatics Div/Tuthill Corp**  
 4840 W Kearney St  
 Springfield, MO 65803  
 Phone: 417-865-8715  
 Fax: 417-865-2950

**M-Tec Corp**  
 1300 W Steel Road  
 Morrisville, PA 19067  
 Phone: 215-295-8208  
 Fax: 215-295-8761

**MAC Corp/Saturn Shredders**  
 201 E Shady Grove Road  
 Grand Prairie, TX 75050  
 Phone: 214-790-7800  
 Fax: 214-790-8733

**MAC Environmental A Div of MAC Equipment Inc**  
 10741 Ambassador Drive  
 Kansas City, MO 64153  
 Phone: 816-891-9300  
 Fax: 816-891-8978

**MEC Co**  
 1400 West Main St  
 Neodesha, KS 66757  
 Phone: 316-325-2673  
 Fax: 316-325-2678

**METCO Environmental**  
 PO Box 598  
 Addison, TX 75001  
 Phone: 214-931-7127  
 Fax: 214-931-8398

**MIOX Corp**  
 5500 Midway Park Place Northeast  
 Albuquerque, NM 87109  
 Phone: 505-343-0090  
 Fax: 505-343-0093

**MKS Instruments Inc**  
 Six Shattuck Road  
 Andover, MA 01810  
 Phone: 508-975-2350  
 Fax: 508-975-0093



**MMC Int'l Corp**  
 60 Inip Drive  
 Inwood, NY 11096  
 Phone: 516-239-7339  
 Fax: 516-239-7339  
**Couplings: Hydrocarbon Detectors; Level Instrumentation; Oxygen Detectors; Sampling Systems; Temperature Instrumentation; Valves**  
**SEE AD ON PAGE 23**

**MMT Environmental Services Inc**  
 4610 N Churchill St  
 St Paul, MN 55126  
 Phone: 612-483-9595

Fax: 612-483-2699  
**MPC Containment System Ltd**  
 4834 S Oakley Ave  
 Chicago, IL 60609-4036  
 Phone: 312-927-4120  
 Fax: 312-927-4120  
 Natl: 800-621-0146  
 Fax: 312-650-6028

**MSA**  
 PO Box 426  
 Pittsburgh, PA 15230  
 Natl: 800-672-2222



**Mabbett & Associates Inc**  
 5 Alfred Circle  
 Bedford, MA 01730-2346  
 Phone: 617-275-6050  
 Natl: 800-877-6050  
 Fax: 617-275-5651

**Magid Glove & Safety Mfg Co**  
 2060 N Kolmar Ave  
 Chicago, IL 60639  
 Phone: 312-384-3070  
 Natl: 800-444-8010  
 Fax: 312-384-6677

**Marathon Equipment Co**  
 PO Box 1798  
 Vernon, NJ 08592  
 Phone: 205-695-8517  
 Natl: 800-269-7237  
 Fax: 205-695-8813

**Marine & Environmental Testing Inc**  
 4115 N Mississippi Ave  
 Chicago, IL 60711  
 Phone: 312-382-6920  
 Fax: 312-382-6929

**Marshall Corp**  
 6213 F Angus Drive  
 Raleigh, NC 27613  
 Phone: 919-871-8788  
 Natl: 800-722-2800  
 Fax: 919-871-6470

**Marshall Industrial Technologies**  
 529 S Clinton Ave  
 Trenton, NJ 08611  
 Phone: 609-394-7153  
 Natl: 800-959-1133  
 Fax: 609-989-7794

**Martin Engineering**  
 One Martin Place  
 Neponset, IL 61345  
 Phone: 309-594-2384  
 Natl: 800-544-2947  
 Fax: 309-594-2432



**Martin Marietta Magnesia Specialties Inc**  
 2323 Eastern Blvd Bldg E  
 Baltimore, MD 21220-0470  
 Phone: 410-780-5500  
 Fax: 410-780-5555

**Mastruc Co, The**  
 PO Box 310978  
 New Braunfels, TX 78131-0978  
 Natl: 800-299-6836  
 Fax: 800-226-2659

**Maxi Container Inc**  
 6000 Caniff  
 Detroit, MI 48212  
 Phone: 313-891-3880  
 Natl: 800-727-6294  
 Fax: 313-891-6476

**Maxi Products Co Inc**  
 2536 Center Ave  
 Janesville, WI 53546  
 Phone: 608-755-1199  
 Natl: 800-833-3740  
 Fax: 608-755-0307

**Maxim Engineers Inc**  
 2342 Fabens  
 Dallas, TX 75355  
 Phone: 214-247-7575  
 Fax: 214-484-5804

**McNeill International**  
 7041 Hodgson Road  
 Mentor, OH 44060  
 Phone: 216-953-0005  
 Natl: 800-626-3455  
 Fax: 216-953-1933

**McTigue Industries Inc**

2100 N Kimball St No. 928  
 Mitchell, SD 57301-1164  
 Phone: 605-996-1162  
 Fax: 605-996-1908  
**Measurement & Flow Control**  
 400 N Lexington Ave  
 Pittsburgh, PA 15208-2599  
 Phone: 412-244-5300

**Medical Coaches**  
 PO Box 129  
 Oneonta, NY 13820  
 Phone: 607-432-1333  
 Fax: 607-432-8190

**Medina Agriculture Products Co Inc**  
 PO Box 309  
 Honda, TX 78861  
 Phone: 210-426-3011  
 Fax: 210-426-2288

**Mefiag Div Met-Pro Corp**  
 160 Cassell Road  
 Harleysville, PA 19438  
 Phone: 215-721-6030  
 Fax: 215-723-6758

**Membrane Technology & Research Inc**  
 1360 Willow Road  
 Menlo Park, CA 94025  
 Phone: 415-328-2228  
 Fax: 415-328-6580



**Met-One Instruments Inc**  
 1600 Washington Blvd  
 Grand, OR 97128  
 Phone: 503-471-7111  
 Fax: 503-471-7116

**Air Pollution Control Equipment; Data Acquisition Equipment; Data Loggers; Enclosures, Structural; Evaporation Equipment; Meteorological; Monitoring Systems, Air; Sensors; Shelters; Temperature Instrumentation; Weather Monitoring**  
**SEE AD ON PAGE 26**



**Met-Pro Corp Systems Div**  
 160 Cassell Road  
 Harleysville, PA 19438  
 Phone: 215-723-6751  
 Fax: 215-723-6161

**Absorption Equipment; Air Pollution Control Equipment; Carbon Adsorption; Catalysts; Clarifiers; Filtration Systems; Groundwater Treatment/Services; Incineration Systems; Landfills Equipment; Leachate Treatment; Metal Recovery Systems; Oil Skimmers; Oxidizers; Packaged Treatment Systems; Pilot Plants; Solvent Recovery Systems; Tanks; VOC Removal Systems; Wastewater Treatment Systems; Water/Wastewater Treatment Equipment; Water/Wastewater Treatment Plants**  
**SEE AD ON PAGE 43**

**Metritape Inc**  
 69 Port Road  
 Littleton, MA 01460-1431  
 Phone: 508-486-9800  
 Fax: 508-486-0170

**Metro Tel Corp**  
 500 N Broadway No. 240  
 New York, NY 10013  
 Phone: 516-937-3420  
 Fax: 516-937-3426

**Metroonics Inc**  
 PO Box 23075  
 Rochester, NY 14692  
 Phone: 716-334-7930  
 Fax: 716-334-2635

**Metrotech Corp**  
 670 National Ave  
 Mountain View, CA 94043  
 Phone: 415-949-4900  
 Fax: 415-962-9527

**Meyer WW & Sons Inc**  
 8261 Elmwood Ave  
 Skokie, IL 60077-2972  
 Phone: 708-673-0312  
 Fax: 708-673-5564

**Micro Air, Air Cleaners by Metal-Fab Inc**  
 PO Box 1138  
 Wichita, KS 67201  
 Phone: 316-943-2351  
 Natl: 800-835-2830  
 Fax: 316-943-2717

**Microbics Corp**  
 2232 Rutherford Road  
 Carlsbad, CA 92008  
 Phone: 619-438-8282  
 Natl: 800-642-7299  
 Fax: 619-438-2980

**Microsensor Systems Inc**  
 62 Corporate Court  
 Bowling Green, KY 42103  
 Phone: 502-745-0099  
 Fax: 502-745-0095

**Midac Corp**  
 1791 Fillet Ave  
 Irvine, CA 92714  
 Phone: 714-660-8558  
 Fax: 714-660-9334

**Midwestco Filter Resources Inc**  
 PO Box 2075, 400 Bataille Drive  
 Winchester, VA 22601  
 Phone: 703-667-9500  
 Natl: 800-336-7300  
 Fax: 703-667-9074

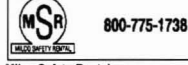

**Mico Safety Rental**  
 9033 W Monroe  
 Houston, TX 77061  
 Phone: 713-947-0050  
 Natl: 800-7-8738  
 Fax: 713-947-1738  
**SEE AD ON PAGE 64**

**Millipore Corp**  
 80 Ashby Road  
 Bedford, MA 01730-2271  
 Phone: 617-275-9200  
 Natl: 800-645-5787  
 Fax: 617-275-5550



**Milltronics Inc**  
 709 Stadium Drive  
 Arlington, TX 76011  
 Phone: 817-277-3543  
 Fax: 817-277-3894  
**SEE AD ON PAGE 16**

**Minuteman Int'l Inc**  
 111 S Rohwing Road  
 Addison, IL 60101  
 Phone: 708-627-6900  
 Fax: 708-627-1130

**Misonix Inc**  
 1938 New Highway  
 Farmingdale, NY 11735  
 Phone: 516-694-9555  
 Fax: 516-694-9412



**Mobile Process Technology**  
 PO Box 14867  
 Memphis, TN 38114  
 Phone: 901-744-1142  
 Natl: 800-238-3028  
 Fax: 901-743-2367  
**SEE AD ON PAGE 48**

**ModuTank Inc**  
 41-04 35th Ave  
 Long Island City, NY 11101  
 Phone: 718-392-1112  
 Fax: 718-786-1008

**Mole Master Services Corp**  
 117 Industry Road  
 Marietta, OH 45750  
 Phone: 614-374-8226  
 Natl: 800-322-6653  
 Fax: 614-374-5908

**Monarch Instrument**  
 15 Columbia Drive  
 Amherst, NH 03031-2334  
 Phone: 603-883-3930  
 Natl: 800-999-3930  
 Fax: 603-886-3300

**Monarch Separators Inc**  
 6827 Signal Drive  
 Houston, TX 77041  
 Phone: 713-466-1974

Fax: 713-466-3014

**Monitor Labs Inc**  
 74 Inverness Drive East  
 Englewood, CO 80112  
 Phone: 303-792-3300  
 Natl: 800-422-1499  
 Fax: 303-799-4853

**Monroe Environmental Corp**  
 11 Port Ave  
 Monroe, MI 48161  
 Phone: 313-242-7654  
 Natl: 800-992-7709  
 Fax: 313-242-5275

**Monsanto Enviro-Chem**  
 PO Box 14547  
 St Louis, MO 63178  
 Phone: 314-275-5700  
 Fax: 314-469-8805

**Moran Manufacturing Inc**  
 PO Box 1264, Highway 65 North  
 Conway, AR 72033  
 Phone: 501-327-6561  
 Fax: 501-327-9126



**Morehouse-Cowles Inc**  
 1600 W Commonwealth Ave  
 Fullerton, CA 92633  
 Phone: 714-738-5000  
 Fax: 714-738-5960

**Morlan & Morlan Inc**  
 PO Box 5945  
 Shreveport, LA 71135  
 Phone: 318-797-3560  
 Fax: 318-797-3560



**Morrison, Knudsen Corp**  
 PO Box 73, 720 Park Blvd  
 Boise, ID 83729  
 Phone: 208-386-5502  
 Fax: 208-386-3658



**Morton International Inc**  
 100 N Riverside Plaza  
 Chicago, IL 60606  
 Phone: 312-807-3108  
 Fax: 312-807-3460



**Mount Sopris Instrument Co**  
 17301 W Colfax Ave No. 255  
 Golden, CO 80401  
 Phone: 303-279-3211  
 Fax: 303-279-2730

**Geophysical Instruments; Groundwater Testing & Monitoring Equipment; Instrument Rental; Water Quality Instrumentation**  
**SEE AD ON PAGE 35**

**Multitek Inc**  
 700 Main St, PO Box 170  
 Frenicoma, WI 54556-0170  
 Phone: 800-744-2000  
 Natl: 800-243-5438  
 Fax: 715-428-2700

**Munters Corp - Cargocaire Div**  
 79 Monroe St  
 Amesbury, MA 01913  
 Phone: 603-883-0800  
 Natl: 800-843-5360  
 Fax: 508-388-4556

**Myron L Co**  
 6115 Corte del Cedro  
 Carlsbad, CA 92009  
 Phone: 619-438-2021  
 Fax: 619-931-9189

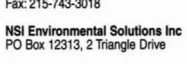

**NSI Environmental Solutions Inc**  
 PO Box 12313, 2 Triangle Drive



Field Testing Instruments/Services; Fittings; Flow Instrumentation; Flowmeters, Maxx; Flowmeters, Variable Area; Gas Detectors; Groundwater Testing & Monitoring Equipment; Heating Cable/Tape; Insulation, Thermal; Laboratory Equipment/Supplies; Laboratory Systems/Testing; Leak Detectors; Level Instrumentation; Level, Sight Gauge; Meters; Moisture Instrumentation; Monitoring Systems; Air; Motor Controllers; Ozone Detectors; Pressure Boosters; Pressure/Vacuum Instrumentation; Process Control Instrumentation; Programmable Controllers/Timers; Pump Controllers; Pumping Stations/Systems; Pumps (Sludge, Wastewater, Groundwater, Misc.); Recorder Accessories; Recorders; Refractometers; Secondary Containment; Signal Conditioners; Soil Sampling Equipment; Stack Flow Meters; Stormwater Monitoring; Stormwater Treatment; Temperature Instrumentation; Transmitters; Turbidity Instrumentation; Valve Actuators/Operators; Valves; Vibration Instruments; Viscosity Instruments; Wastewater Treatment Systems; Water Meters; Weather Monitoring; Weighing Equipment; PH Instrumentation

Fax: 201-244-0722



**Ozonair Intl Corp**  
903 Grandview Drive  
San Francisco, CA 94080  
Phone: 415-952-9904  
Fax: 415-952-1287

**Ozone Research & Equipment Corp An Osmonics Co (OREC)**  
4953 W Missouri Ave  
Phoenix, AZ 85301  
Phone: 602-931-7332  
Natl: 800-321-8200  
Fax: 602-931-7727

**PACE Environmental Products**  
1196 Easton Road  
Horsham, PA 19044  
Phone: 215-957-1144  
Fax: 215-957-1186

**PDG Environmental Inc**  
300 Oxford Drive  
Monroeville, PA 15146  
Phone: 610-834-0176  
Fax: 610-834-0264

**Pace Transducer/CJ Enterprise**  
PO Box 570430  
Tazana, CA 91357-0430  
Phone: 818-996-4131  
Fax: 818-700-8272

**Pacer Pumps**  
One Lark Ave  
Leola, PA 17540-9512  
Phone: 717-656-2161  
Natl: 800-233-3861  
Fax: 717-656-0477

**Pacer Pumps Div ASM Industries Inc**  
One Lark Ave  
Leola, PA 17540-9512  
Phone: 717-656-2161  
Natl: 800-233-3861  
Fax: 717-656-0477

**Pacific Analytical Inc**  
6349 Paseo Del Lago  
Carlsbad, CA 92009  
Phone: 619-436-3100  
Fax: 619-931-9479

**Packaging Research & Design**  
PO Box 678  
Madison, MS 39130-0678  
Phone: 601-856-9791  
Natl: 800-933-9364  
Fax: 601-853-1202

**Paco Pumps**  
800 Koomery Road  
Brookshire, TX 77423  
Phone: 713-934-6012  
Natl: 800-955-5847  
Fax: 713-934-6090



**Pallflex Products Co**  
125 Kennedy Drive  
Putnam, CT 06260  
Phone: 203-928-7761  
SEE AD ON PAGE 34

**Panamericas PCI Div**  
211 Crescent St  
Waltham, MA 02154



**Parker Hannifin Corp**  
17325 Euclid Ave  
Cleveland, OH 44112  
Phone: 216-531-3000  
Natl: 800-272-7537  
Fax: 216-486-0618  
Actuators; Air Filters; Bushings; Couplings; Filter Accessories; Filtration Systems; Fittings; Gaskets/Packing/Seals; Hose/Tubing; Oil/Water Separation; Process Control Instrumentation; Regulators; Separators; Valve Actuators/Operators; Valves; Positioners; Valve Systems; Valves  
SEE AD ON PAGE 144

**Parline Inc**  
PO Box 65  
Winfield, WV 25213  
Phone: 304-586-2113  
Natl: 800-786-4855  
Fax: 304-586-3842

**Parson Corp**  
PO Box 408399  
Fort Lauderdale, FL 33340-8399

**Parsons Engineering Science Inc**  
100 W Walnut St  
Pasadena, CA 91124  
Phone: 818-440-6000  
Fax: 818-440-6195

**Peek Measurement Inc**  
10335 Landsbury No. 300  
Houston, TX 77099  
Phone: 713-879-3700  
Fax: 713-498-7721

**Penberthy Electromet**  
631 S 96th St  
Seattle, WA 98108-4914  
Phone: 206-762-1444  
Fax: 206-763-9331

**Pentek Inc**  
1026 Fourth Ave  
Corapolis, PA 15108  
Phone: 412-262-0725  
Fax: 412-262-0731

**Peoria Disposal Co**  
4700 N Sterling Ave  
Peoria, IL 61615  
Phone: 309-688-0760  
Fax: 309-688-0881

**Pepon Systems Inc**  
3770 Howard Hughes No. 340  
Las Vegas, NV 89109

**Perkin-Elmer Corp**  
761 Main Ave  
Norwalk, CT 06859  
Phone: 203-762-1000  
Natl: 800-762-4000  
Fax: 203-762-6000

**Peroxidation Services Inc**  
5151 E Broadway Blvd No. 600  
Tucson, AZ 85711-3712

**Perstorp Analytical Inc**  
9445 SW Ridder Road  
Wilsonville, OR 97070  
Phone: 503-682-3848  
Natl: 800-262-3668  
Fax: 503-685-9218

**Petrol Corp**  
874 Albany-Shaker Road  
Latham, NY 12110  
Phone: 518-783-5133  
Fax: 518-783-5185

**Phenomenex**  
2320 W 205th St  
Torrance, CA 90501  
Phone: 310-212-0555  
Fax: 310-328-7768

**Phixps & Bird Inc**  
8741 Landmark Road  
Richmond, VA 23228-2801  
Phone: 804-264-7590  
Natl: 800-955-7621  
Fax: 804-264-3134

**Phonetics Inc**  
901 Tryens Road  
Aston, PA 19014  
Phone: 610-558-2700  
Fax: 610-558-0222

**Photovac Monitoring Instruments**  
516-254-4199

**Photovac Monitoring Instruments**  
25-B Jeffry Blvd West  
Deer Park, NY 11729  
Phone: 516-254-4199  
Fax: 516-254-4284

**Air Analyzers; Air Emissions Monitoring Equipment; Air Quality Instrumentation; Air Samplers; Analysis; Gas Chromatography; Analytical Instruments; Analytical Instruments, Air; Analytical Instruments, Hazardous Materials; Analytical Instruments, Wastewater; Analytical Instruments, Water; Chromatographs; Combustible Gas Detectors; Gas Detectors; Chromatographs; Gas Detectors; Hydrocarbon Detectors; Monitoring Systems, Air; Monitoring Systems, Hazardous Material; Monitoring Systems,**

**Water; Sampling Systems; Soil Sampling Equipment; Stack Emission Monitors; Toxic Gas Detectors; Underground Tank Leak Monitors**  
SEE AD ON PAGE 42

**Pipe Liners Inc (U-Linear Pipe)**  
101 Teal St  
St Rose (New Orleans), LA 70087  
Phone: 504-461-9810  
Natl: 800-344-3744  
Fax: 504-466-1712

**Piqua Waste Equipment Co**  
PO Box 911, 125 Clark Ave  
Piqua, OH 45356  
Phone: 513-773-2464  
Natl: 800-543-8950  
Fax: 513-778-1320

**Plainsol**  
452 Hudson Terrace 2nd Floor  
Englewood, NJ 07632  
Phone: 800-877-2436  
Natl: 201-569-1513

**Plastic Fab Inc**  
PO Box 100  
Tualatin, OR 97062  
Phone: 503-692-5460  
Fax: 503-692-1145

**Plastic Film Enterprises**  
1921 Bellaire Ave  
Royal Oak, MI 48067  
Phone: 810-399-0450  
Natl: 800-574-6553  
Fax: 810-399-2534

**Plastic Fusion Fabricators**  
3455 Stanwood Blvd Northeast  
Huntsville, AL 35811-9021  
Phone: 205-852-0378  
Natl: 800-356-1480  
Fax: 205-852-0388

**Plexco**  
1050 Busse No. 200  
Bensenville, IL 60106  
Phone: 708-350-3700  
Fax: 708-350-2704

**Pollution Control Inc**  
7529 Sussex Drive  
Florence, KY 41042  
Phone: 606-282-2200  
Natl: 800-446-4724  
Fax: 606-282-2205

**Poly-Flex Inc**  
2000 W Marshall Ave  
Grand Prairie, TX 75051  
Phone: 214-647-4374  
Natl: 800-527-3322  
Fax: 214-988-8331

**Polybac Corp**  
3904 Courtney St  
Bethlehem, PA 18017  
Phone: 610-867-7338  
Natl: 800-523-9385  
Fax: 610-861-0991

**Polyfoam Packers Corp**  
2320 Courtny Ave  
Wheeling, IL 60090  
Phone: 708-398-0110  
Natl: 800-227-8865  
Fax: 708-398-0653

**Polyspec Corp**  
PO Box 682336  
Houston, TX 77269

**Pope Scientific**  
PO Box 495  
Menomonee Falls, WI 53051  
Phone: 414-251-9300  
Fax: 414-251-7387

**Porta-Fab Corp**  
18080 Chesterfield Airport Road  
Chesterfield, MO 63005  
Phone: 314-537-5555  
Natl: 800-325-3781  
Fax: 314-537-2955

**Portec Construction Equip Div**  
700 W 21 St, PO Box 20  
Yankton, SD 57078  
Phone: 605-665-8771  
Fax: 605-665-8858

**Power Coasting Institute Inc**  
2121 Eisenhower Ave  
Alexandria, VA 22314  
Phone: 703-684-1770  
Fax: 703-684-1771  
Spraying Equipment

SEE AD ON PAGE 63

**Power Plant Services**  
2500 W Jefferson  
Fort Wayne, IN 46802  
Phone: 219-432-8716  
Fax: 219-436-3340

**Powers Process Controls**  
3400 Oakton St  
Skokie, IL 60076  
Phone: 708-673-8700  
Fax: 708-673-9044

**Presray Corp**  
159 Charles Colman Blvd  
Pawling, NY 12564  
Phone: 914-855-1230  
Fax: 914-855-1199

**Price-Darnall Inc of Alabama**  
3263 Demetropolis Road No. 11  
Mobile, AL 36693  
Phone: 205-666-7301  
Fax: 205-666-7300

**Primatex Inc**  
445 Hutchinson Ave No. 200  
Columbus, OH 43235-5677

**Pro-Am Software**  
551 Keystone Drive  
Warrendale, PA 15086  
Phone: 412-773-1818  
Natl: 800-652-7316

**Pro-Tech Respirators Inc**  
107 E Alexander St  
Buchanan, MI 49107-1549  
Phone: 616-695-9663  
Fax: 616-695-1415

**ProMinent Fluid Controls Inc**  
136 Industry Drive  
Pittsburgh, PA 15275  
Phone: 412-787-2484  
Fax: 412-787-0704

**Process Combustion Corp**  
PO Box 12866  
Pittsburgh, PA 15243  
Phone: 412-655-0955  
Fax: 412-655-0961

**Process Solutions**  
3630 Consumer St No. 101  
Riviera Beach, FL 33404  
Phone: 407-840-0050  
Fax: 407-840-0070

**Production Systems Inc**  
850 Mountain Industrial Drive  
Marietta, GA 30060-7908  
Phone: 404-424-9784  
Natl: 800-235-9734  
Fax: 404-424-8392

**Professional Analytical & Consulting Services Inc**  
409 Mead Drive  
Corapolis, PA 15108-9616  
Phone: 412-457-6576  
Fax: 412-457-1214

**Professional Service Industries Inc**  
510 E 22nd St  
Lombard, IL 60148  
Phone: 913-865-9236  
Natl: 800-548-7970  
Fax: 913-865-9170

**Programming Technology**  
2800 Boone Ave North  
Minneapolis, MN 55427  
Phone: 612-541-9998  
Fax: 612-541-9998

**Progressive Equipment Corp**  
413 E Ninth St  
Erie, PA 16503  
Phone: 814-452-4363  
Natl: 800-548-6089  
Fax: 814-459-3094

**Protect**  
7136 S Yala Ave No. 200  
Tulsa, OK 74136-6315

**Purestream Inc**  
PO Box 68  
Florence, KY 41022  
Phone: 606-371-9898  
Fax: 606-371-3577

**Purus Inc**  
2713 N First St  
San Jose, CA 95134  
Phone: 408-955-1000  
Fax: 408-955-1010

**QED GroundWater Specialists**  
PO Box 3726

Ann Arbor, MI 48106  
Phone: 313-995-2547  
Nat'l: 800-624-2026  
Fax: 313-995-1170

**Qualometrics Inc**  
1165 National Drive  
Sacramento, CA 95834  
Phone: 916-928-1000  
Nat'l: 800-824-5873  
Fax: 916-928-1165

**Quality Industries Inc**  
1920 Canal Blvd  
Thibodaux, LA 70302  
Phone: 504-447-4021  
Nat'l: 800-447-8403  
Fax: 504-447-4028

**R**

**R E Wright Associates Inc (REWI)**  
3240 Schoolhouse Road  
Middletown, PA 17057-3595  
Phone: 717-944-5501  
Nat'l: 800-944-6778  
Fax: 717-944-5642

**R Excavating Inc.**  
"Environmental Contractor"  
15 S 14th St  
Council Bluffs, IA 51501  
Phone: 712-329-1016  
Nat'l: 800-655-7545  
Fax: 712-323-4766



616-946-3980

**R M Young Co**  
2801 Aero Park Drive  
Traverse City, MI 49686  
Phone: 616-946-3980  
Fax: 616-946-4772  
Air Quality Instrumentation;  
Meteorological; Oceanographic  
Equipment; Temperature  
Instrumentation  
SEE AD ON PAGE 47

**R-P Products**  
407 Jefferson St, PO Box 388  
Three Rivers, MI 49093-0388  
Phone: 616-273-1512  
Fax: 616-273-1812

**RGF Environmental Systems Inc**  
3875 Fiscal Court  
West Palm Beach, FL 33404  
Phone: 407-848-1826  
Nat'l: 800-842-7771  
Fax: 407-845-1251

**RJ Industries Inc**  
PO Box 565  
Norwalk, CT 06856  
Phone: 203-966-7200  
Nat'l: 800-255-7211  
Fax: 203-866-1344

**RMJ Machinery Inc**  
4915 Van Epps Road  
Cleveland, OH 44131  
Phone: 216-351-8900  
Fax: 216-351-9508

**RMT Inc**  
744 Heartland Trail, PO Box 8923  
Madison, WI 53717  
Phone: 608-831-4444  
Fax: 608-831-3334

**Radian Corp**  
PO Box 201088  
Austin, TX 78720-1088  
Phone: 512-454-4797  
Fax: 512-454-7129

**Raytheon Engineers & Constructors/ Raytheon Enviro Svcs**  
13105 NW Freeway No. 300  
Houston, TX 77040  
Phone: 713-329-4000  
Fax: 713-329-4417

**Recon Environmental**  
5 Johnson Drive  
Raritan, NJ 08869  
Phone: 908-526-1000  
Fax: 908-526-7886

**Red Bird Service**  
205 Western Ave  
Osgood, IN 47037  
Nat'l: 800-428-3502  
Fax: 612-889-4061

**Reef Industries Inc**  
PO Box 750250  
Houston, TX 77215-0250  
Phone: 713-943-0070  
Nat'l: 800-231-6074

Fax: 713-947-2053

**Regulation Scanning**  
30 W Third St  
Williamsport, PA 17701-6513  
Phone: 717-323-1010  
Nat'l: 800-326-8303  
Fax: 717-323-8082

**Reiss Corp**  
Box 72  
Blackstone, VA 23824  
Phone: 804-292-1600  
Fax: 804-292-1757

**Reliance Electric Co**  
24701 Euclid Ave, PO Box 17448  
Cleveland, OH 44117  
Phone: 216-266-7000  
Nat'l: 800-245-4501  
Fax: 216-266-7120

**Remco Engineering**  
408 Bryant Circle  
Ojai, CA 93024-0910  
Phone: 805-640-0086  
Fax: 805-640-0093

**Remco Products Corp**  
4735 W 106th St, PO Box 698  
Zionsville, IN 46077  
Phone: 317-876-9856  
Fax: 317-876-9858

**Remedial Systems Inc**  
56 Leonard St  
Foxboro, MA 02035  
Phone: 508-543-1512  
Fax: 508-543-7485

**Research Products/Blankenship**  
2639 Andjon Drive  
Dallas, TX 75220  
Phone: 214-358-4238  
Nat'l: 800-527-5551  
Fax: 214-350-7919

**Resource Consultants Inc**  
**CHEMTOX Div**  
7121 Crossroads Blvd  
Brentwood, TN 37027  
Phone: 615-373-5040  
Nat'l: 800-338-2815  
Fax: 615-370-4339

**Resources Conservation Co**  
3006 Northup Way  
Bellevue, WA 98004-1407  
Phone: 206-828-2400  
Fax: 206-828-0526

**Response Rentals**  
1057 E Henrietta Road  
Rochester, NY 14623  
Phone: 716-424-2140  
Nat'l: 800-242-3910  
Fax: 716-424-2166

**Restek Corp**  
110 Bennet Circle  
Bellefonte, PA 16823  
Phone: 814-353-1300  
Nat'l: 800-356-1688  
Fax: 814-353-1309

**Revere Products**  
PO Box 35311  
Cleveland, OH 44135  
Nat'l: 800-321-1976  
Fax: 800-966-0502

**Rhombus Technology**  
PO Box 1619, County Road 6  
Detroit Lakes, MN 56502  
Phone: 218-847-4786  
Nat'l: 800-746-6287  
Fax: 218-847-4801

**Rhône-Poulenc Inc**  
**Specialty Chemicals Div**  
CRN-7500 Prospect Plains Road  
Cranbury, NJ 08512-7500  
Phone: 609-860-4000

**Ridge Tool Co**  
400 Clark St  
Elyria, OH 44036  
Phone: 216-323-5581

**Robbins & Myers Inc/Moyno**  
**Industrial Products Div**  
1895 W Jefferson St  
Springfield, OH 45506  
Phone: 513-327-3553  
Fax: 513-327-3572

**Robinson Industries Inc**  
PO Box 100  
Zellenople, PA 16063  
Phone: 412-452-6121  
Fax: 412-452-0388

**Rochester J L Co**  
65 Hillhurst Lane  
Rochester, NY 14617-1943

Phone: 716-467-7816  
Fax: 716-467-6853  
**Rollins Environmental**  
PO Box 2349  
Wilmington, DE 19899

**Ronningen-Petter, Engineered**  
**Filter Systems**  
9151 Shaver Road, PO Box 188  
Portage, MI 49081-0188  
Phone: 616-323-1313  
Nat'l: 800-656-3344  
Fax: 616-323-2403

**Roots Div/Dresser Industries**  
900 W Mount St  
Connersville, IN 47331-1675  
Phone: 317-827-9200  
Fax: 317-825-7669

**Rosemont Analytical**  
3240 Scott Blvd  
Santa Clara, CA 95054-3011

**Rosemont Analytical Inc**  
1201 N Main St  
Orville, OH 44667-0901  
Phone: 216-682-9010  
Nat'l: 800-628-1200  
Fax: 216-684-4458

**Ross Air Systems**  
PO Box 791  
New Brunswick, NJ 08903  
Phone: 908-356-6000  
Fax: 908-356-0643

**Ross Incineration Services Inc**  
36790 Giles Road  
Grafton, OH 44044  
Phone: 216-748-2171  
Nat'l: 800-878-7677  
Fax: 216-748-1267

**Rotork Controls Inc**  
19 Jetview Drive  
Rochester, NY 14624  
Phone: 716-328-5518  
Fax: 716-328-5848

**Royal Wire Products**  
13450 York Delia Drive  
North Royalton, OH 44133  
Phone: 216-237-8787  
Fax: 216-237-9330

**Rust Environment & Infrastructure**  
15 Brendan Way  
Greenville, SC 29615  
Phone: 803-234-3000  
Nat'l: 800-866-0373  
Fax: 803-234-3069

**Rust International Inc**  
100 Corporate Parkway  
Birmingham, AL 35242  
Phone: 205-995-7878  
Fax: 205-995-7355

**S**

**S & G Enterprises Inc**  
N115 W19000 Edison Road  
Germantown, WI 53022  
Phone: 414-251-8300  
Nat'l: 800-233-3271  
Fax: 414-251-1616

**S J Electro Systems Inc**  
PO Box 1619, County Road 6  
Detroit Lakes, MN 56502  
Phone: 218-847-1317  
Fax: 218-847-4617

**SIE Div of Computalog USA**  
500 Winscott Road  
Fort Worth, TX 76126  
Phone: 817-249-7200  
Fax: 817-249-7222

**SKC Inc**  
863 Valley View Road  
Eighty Four, PA 15330  
Phone: 412-941-9701  
Nat'l: 800-752-9472  
Fax: 412-941-1369

**SRI Instruments**  
3882 Del Amo Blvd No. 601  
Torrance, CA 90503  
Phone: 310-214-5092  
Fax: 310-314-5097

**SRS Crisafulli Inc**  
PO Box 1051, Crisafulli Drive  
Glendive, MT 59330-1051  
Phone: 406-365-3393  
Nat'l: 800-442-7867  
Fax: 406-365-2249

**SSI Shredding Systems Inc**  
9760 SW Freeman Drive  
Wilsonville, OR 97070-9286  
Phone: 503-682-3633

Fax: 503-682-1704

**SSM/Spotts Stevens & McCoy Inc**  
345 N Wymissing Blvd  
Reading, PA 19610  
Phone: 610-376-6581  
Fax: 610-326-6950

**STP Specialty Technical Publishers**  
PO Box 3427  
Blaine, WA 98231-3427  
Nat'l: 800-933-3352  
Fax: 604-983-3445

**SWAN/Industries Analytcs**  
50 Mungerton Road  
Madison, CT 06443  
Phone: 203-245-0380  
Fax: 203-245-3698

**Safe Environmental Storage Corp**  
180 Devon Ave  
Bensenville, IL 60016  
Phone: 708-595-0666  
Nat'l: 800-593-7233  
Fax: 708-350-0481



**Safety Kleen Corp**  
777 Big Timber Road  
Elgin, IL 60123  
Phone: 708-697-6460



**Safety Storage Inc**  
2301 Bert Drive  
Hollister, CA 95023  
Phone: 408-837-5955  
Nat'l: 800-344-6539  
Fax: 408-837-7405  
SEE AD ON PAGE 70

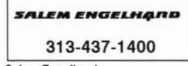

**Salem Engelhard**  
245 S Mill  
South Lyon, MI 48178  
Phone: 810-437-1400  
Fax: 810-437-7924  
SEE AD ON PAGE 119

**Sauereisen**  
160 Gamma Drive  
Pittsburgh, PA 15238  
Phone: 412-963-0303  
Fax: 412-963-7620

**Schneider Instrument Co**  
8115 Camargo Road  
Cincinnati, OH 45243  
Phone: 513-561-6803  
Fax: 513-527-4375



**Sehnstedt Instrument Co**  
1775 Wiehle Ave  
Reston, VA 22090  
Phone: 703-471-1050  
Fax: 703-471-1795  
SEE AD ON PAGE 109

**Schreiber Corp Inc**  
100 Schreiber Drive  
Trussville, AL 35173  
Phone: 205-655-7466  
Fax: 205-655-7669

**Schuller International Inc**  
PO Box 5108  
Denver, CO 80217  
Phone: 303-978-4900  
Nat'l: 800-654-3103  
Fax: 303-978-2318

**Schutte & Koerting Division**  
**Ketema Inc**  
2233 Slate Road  
Bensalem, PA 19020-7253  
Phone: 215-639-0900  
Fax: 215-639-1597

**Scientific Specialties Services Inc**  
PO Box 352  
Randallstown, MD 21133  
Phone: 410-712-4400  
Nat'l: 800-648-7800  
Fax: 410-712-4401

**Scott Aviation, A Figgie Intl Co**  
309 W Crowell St

Monroe, NC 28112  
Phone: 704-282-8400  
Fax: 704-282-8424

**Sebright Products Inc**  
127 N Water St  
Hopkins, MI 49328  
Phone: 616-793-7183  
Fax: 616-793-4022

**Seneca Environmental**  
**Services Inc**  
4509 NE 14th St  
Des Moines, IA 50313  
Phone: 515-262-3500  
Nat'l: 800-369-3500  
Fax: 515-262-2469

**Sensidyne Inc**  
16333 Bay Vista Drive  
Clearwater, FL 34620  
Phone: 812-530-3602  
Nat'l: 800-451-9444  
Fax: 813-539-0550

**Sensor Electronics Corp**  
4539 Lincoln Drive  
Minneapolis, MN 55436  
Phone: 612-938-9486  
Nat'l: 800-285-3651  
Fax: 612-938-9617

**Sensex**  
1166 S Seaboard Drive  
Stanton, CA 90680  
Phone: 714-895-4344  
Fax: 714-894-4839

**Sentex Systems Inc**  
553 Broad Ave  
Ridgefield, NJ 07657-2329  
Phone: 201-945-3694  
Nat'l: 800-736-8394  
Fax: 201-941-6064



**Sentry Polymers Inc**  
5500 E Hwy 332, PO Box 2076  
Freeport, TX 77541  
Phone: 409-233-0312  
Nat'l: 800-231-2544  
Fax: 409-233-4922

**Serengeti Environmental**  
PO Box 772503  
Houston, TX 77215-2503  
Phone: 713-266-4300  
Fax: 713-266-4339

**Serfilco Ltd**  
1777 Sherman Road  
Northbrook, IL 60062-5360  
Phone: 708-559-1777  
Nat'l: 800-323-5431  
Fax: 708-559-1995

**Serio-Uls Lock**  
7466 New Ridge Road No. 20  
Hanover, MD 21076  
Phone: 410-850-8380  
Nat'l: 800-245-6251  
Fax: 410-850-8362

**Serpentix Conveyor Corp**  
9085 Marshall Ct  
Westminster, CO 80030-2920  
Phone: 303-430-8427  
Fax: 303-430-7337

**Serrot Corp**  
5401 Argosy Drive  
Huntington Beach, CA 92649

**Servomex Co Inc**  
90 Kerry Place  
Norwood, MA 02062  
Phone: 617-769-7710  
Nat'l: 800-862-0200  
Fax: 617-769-2834



**Sevenson Environmental**  
**Services Inc**  
2749 Lockport Road  
Niagara Falls, NY 14302  
Phone: 716-284-0431  
Fax: 716-284-1796

**Sew Eurodrive**  
1275 Old Spartanburg  
Lynan, SC 29365-1620  
Phone: 803-439-7537  
Fax: 803-949-3039

**Sewall, James W Co**  
147 Center St  
Old Town, ME 04468-1625



Phone: 207-827-4456  
 Natl: 800-648-4202  
 Fax: 207-827-3641

**Sharples, Business Unit of Alfa Laval Separation**  
 955 Mearns Road  
 Warminster, PA 18974  
 Phone: 215-443-4000  
 Natl: 800-782-3751  
 Fax: 215-443-4139

**Shortridge Instruments Inc**  
 785 E Redfield Road  
 Scottsdale, AZ 85260-3430  
 Phone: 602-991-6744  
 Fax: 602-443-1367



**Shred-Tech**  
 295 Pinebush Road  
 Cambridge, ONT M1T1B2  
 Phone: 519-621-3560  
 Fax: 519-621-0688  
**SEE AD ON PAGE 38**

**Siemens Industrial Automation Inc**  
 100 Technology Drive  
 Alpharetta, GA 30022  
 Phone: 404-740-3944  
 Fax: 404-740-3998

**Sierra Monitor Corp**  
 1991 Tarob Court  
 Millipitas, CA 95035  
 Phone: 408-262-8611  
 Fax: 408-262-9042

**Sievers Instruments Inc**  
 2500 Central Ave  
 Boulder, CO 80301  
 Phone: 303-444-2009  
 Natl: 800-255-6964  
 Fax: 303-444-9543

**Signmark Div/Brady USA Inc**  
 2221 W Camden Road  
 Milwaukee, WI 53209  
 Phone: 414-228-1411  
 Natl: 800-635-7557  
 Fax: 414-228-5993

**Simpson Electric Co**  
 853 Dundee Ave  
 Elgin, IL 60120  
 Phone: 708-697-2260  
 Fax: 708-697-2272

**Sixnet**  
 PO Box 767  
 Clifton Park, NY 12065  
 Phone: 518-877-5173  
 Fax: 518-877-8346

**Skolnik Industries Inc**  
 4900 S Kilbourn Ave  
 Chicago, IL 60632-4593

**Silkwik Sorbents**  
 480 W Dussel Drive  
 Maumee, OH 43537  
 Phone: 419-893-5050  
 Natl: 800-331-3747  
 Fax: 419-891-6539

**Smith & Loveless Inc**  
 14040 Santa Fe Trail Drive  
 Lenexa, KS 66215-1284  
 Phone: 913-888-5201  
 Fax: 913-888-2173



**Smith Fiberglass Products**  
 2700 W 65th St  
 Little Rock, AR 72209-8591  
 Phone: 501-568-4010  
 Fax: 501-568-4465

**Soil & Material Engineers Inc**  
 43980 Plymouth Oaks Blvd  
 Plymouth, MI 48170-9837  
 Phone: 313-454-9900  
 Fax: 313-454-0629

**Soil Safe**  
 4600 E Fayette St  
 Baltimore, MD 21224  
 Phone: 410-327-5753  
 Fax: 410-327-6960



**1-800-661-2023**

**Solinst**  
 35 Todd Road

**Georgetown, ON L7G 4R8**  
**Phone: 905-873-2255**  
**Natl: 800-661-2023**  
**Fax: 905-873-1992**  
**SEE AD ON PAGE 39**

**Solomat**  
 26 Pearl St  
 Norwalk, CT 06850  
 Phone: 203-849-3111  
 Natl: 800-932-4500  
 Fax: 203-847-9320

**Solox A Division of Solar Kinetics Inc**  
 10635 King William Drive  
 Dallas, TX 75220  
 Phone: 214-556-2376  
 Fax: 214-869-4158

**Soltec Corp**  
 12977 Arroyo St  
 San Fernando, CA 91340  
 Phone: 818-365-0800  
 Natl: 800-423-2344  
 Fax: 818-365-7839

**Sonoma Technology Inc**  
 5510 Skyline Blvd  
 Santa Rosa, CA 95403  
 Phone: 707-527-9372  
 Fax: 707-527-9398

**Sparling Instruments Co Inc**  
 4097 N Temple City Blvd  
 El Monte, CA 91731  
 Phone: 818-444-0571  
 Fax: 818-450-0723

**Spartan Mfg Corp**  
 PO Box 917  
 Kernersville, NC 27285-0917  
 Phone: 910-996-5585  
 Fax: 910-996-6217

**Speakman Co**  
 PO Box 181  
 Wilmington, DE 19899-0191  
 Phone: 302-764-9100  
 Fax: 302-764-1956

**Specialty Mfg Co, The**  
 5858 Centerville Road  
 St Paul, MN 55127  
 Phone: 612-653-0599  
 Fax: 612-653-0989

**Spectraserv**  
 75 Jacobus Ave  
 South Kearney, NJ 07032  
 Phone: 201-589-0277  
 Natl: 800-445-4436  
 Fax: 201-589-0415

**Spectrogram Corp**  
 385 State St  
 North Haven, CT 06473  
 Phone: 203-281-0121  
 Fax: 203-248-8827

**Spectronics Corp**  
 956 Brush Hollow Road  
 Westbury, NY 11590  
 Phone: 516-333-4840  
 Natl: 800-274-8898  
 Fax: 516-333-4859

**Spectrum Chemical & Safety Products**  
 14422 S San Pedro St  
 Gardena, CA 90248  
 Phone: 310-516-8000  
 Natl: 800-772-8786  
 Fax: 310-516-9843

**Spectrum Medical Industries**  
 1100 Rankin Road  
 Houston, TX 77073  
 Natl: 800-634-3300  
 Phone: 800-445-7330  
 Fax: 800-445-7330

**Spraying Systems Co**  
 North Ave at Schmale Rd  
 PO Box 7900  
 Wheaton, IL 60189-7900  
 Phone: 708-665-5000  
 Fax: 708-260-0842

**Stanley Consultants Inc**  
 Environmental Inc  
 8501 W Higgins Road  
 Chicago, IL 60631  
 Phone: 312-693-9741  
 Fax: 312-693-7690

**Stanley Consultants Inc**  
 225 Iowa Ave, Stanley Bldg  
 Muscatine, IA 52761  
 Phone: 319-264-6600  
 Fax: 319-264-6658

**Stanley-Vidmar Inc**  
 11 Grammes Road  
 Allentown, PA 18103  
 Natl: 800-523-9462

Fax: 800-523-9934

**Staplex - Air Sampler Div**  
 777 Fifth Ave  
 Brooklyn, NY 11232-1695  
 Phone: 718-383-3333  
 Natl: 800-221-0822  
 Fax: 718-965-0750  
**Star Systems Filtration Division/Hilliard of US Inc**  
 PO Box 518  
 Timmonsville, SC 29161  
 Natl: 800-346-3101  
 Fax: 803-346-3736

**Starcco Co Inc**  
 2033 Hitzert Court  
 St Louis, MO 63026-2506  
 Phone: 314-349-6606  
 Natl: 800-325-4259  
 Fax: 314-349-6078

**Stearns & Wheeler**  
 One Remington Park Drive  
 Cazenovia, NY 13035  
 Phone: 315-655-8161  
 Fax: 315-655-4180

**Steel Tank Association**  
 570 Oakwood Road  
 Lake Zurich, IL 60047-1585  
 Phone: 708-438-8265  
 Fax: 708-438-9209

**Steele Inc**  
 PO Box 7304  
 Kingston, WA 98346-0050  
 Phone: 206-297-4555  
 Fax: 206-297-2816

**Stockhausen**  
 2408 Doyle St  
 Greensboro, NC 27406-2900  
 Phone: 910-333-3561  
 Natl: 800-334-0242  
 Fax: 910-333-3518

**Stokes Vacuum Inc**  
 5500 Tabor Road  
 Philadelphia, PA 19120  
 Phone: 215-831-5400  
 Fax: 215-831-5420

**Stord Inc**  
 309 S Regional Road  
 Greensboro, NC 27409-9674  
 Natl: 800-668-7727  
 Fax: 910-668-0537

**Stranco Inc**  
 5195 Industrial Drive, PO Box 389  
 Bradley, IL 60915  
 Phone: 815-932-8154  
 Natl: 800-882-6466  
 Fax: 815-939-9845

**Stratifiq Software**  
 4175 Harlan St, No. 200  
 West Ridge, CO 80033-5150  
 Phone: 303-423-0221  
 Natl: 800-783-0250  
 Fax: 303-423-8757

**Structure Probe Inc/SPI Supplies**  
 PO Box 656  
 West Chester, PA 19381-0656  
 Phone: 610-436-5400  
 Natl: 800-242-4774  
 Fax: 610-436-5755

**Suburba Systems Corp**  
 149 Miller St, PO Box 1638  
 Wilkes-Barre, PA 18705  
 Phone: 717-823-4037  
 Fax: 717-829-4515

**Summit Training Source**  
 2660 Horizon Drive Southeast  
 Grand Rapids, MI 49546  
 Phone: 616-949-4343  
 Natl: 800-842-0466  
 Fax: 616-949-5720

**Sunshine Technology Corp**  
 2475 Albany Ave  
 West Hartford, CT 06117  
 Phone: 203-232-9227

**Superior Environmental Corp**  
 2201 Wolf Lake Road  
 Muskegon, MI 49442-4845  
 Phone: 616-778-5558  
 Natl: 800-968-8490  
 Fax: 616-778-5450

**Superior Signal Co Inc**  
 PO Box 96  
 Spotswood, NJ 08884  
 Phone: 908-251-0800  
 Fax: 908-251-9442

**Surco Products Inc**  
 PO Box 777, 8th & Pine Ave  
 Braddock, PA 15104  
 Natl: 412-351-7700

Natl: 800-556-0111  
 Fax: 412-351-7701



**Surface Combustion Inc**  
 1700 Indian Wood Circle  
 Maumee, OH 43537  
 Phone: 419-891-7150  
 Natl: 800-828-2558  
 Fax: 419-891-7151

**Susquehanna Valley Systems Inc**  
 920 Seventh Ave, PO Box 804  
 Benwick, PA 18603  
 Phone: 717-759-0174  
 Natl: 800-828-2558  
 Fax: 717-752-7917

**Sutorbill/Duroflow/Gardner Denver**  
 1800 Gardner Expressway  
 Quincy, IL 62301  
 Phone: 217-227-5400  
 Fax: 217-224-7814

**Sverdrup Environmental Inc**  
 13723 Riverport Drive  
 Maryland Heights, MO 63043  
 Phone: 314-436-7600  
 Natl: 800-325-7910  
 Fax: 314-470-5110

**Swagelok Companies, The**  
 31400 Aurora Road  
 Solon, OH 44139  
 Phone: 216-349-5934  
 Fax: 216-349-5843



**Swenson Process Equipment Inc**  
 15700 Lathrop Ave  
 Harvey, IL 60426  
 Phone: 708-331-5500  
 Fax: 708-331-5559

**Sybron Chemicals Inc**  
 Birmingham Road, PO Box 66  
 Birmingham, NJ 08011  
 Phone: 609-893-1100  
 Natl: 800-678-0020  
 Fax: 609-894-8641

**Synthetic Industries - Construction Products Div**  
 4019 Industry Drive  
 Chattanooga, TN 37416  
 Phone: 615-899-0444  
 Natl: 800-621-0444  
 Fax: 615-899-7619

**Systech Environmental Corp**  
 245 N Valley Road  
 Xenia, OH 45385  
 Phone: 513-372-8077  
 Natl: 800-888-8011  
 Fax: 513-374-4133

**T**

**TIMCO Mfg Inc**  
 851 15th St  
 Prairie de Sac, WI 53578  
 Phone: 608-643-8534  
 Natl: 800-236-8534  
 Fax: 608-643-4275

**TRAK Environmental Group Inc**  
 4125 Market St No. 19  
 Ventura, CA 93003  
 Phone: 805-660-5333  
 Fax: 805-660-5710

**TSI Inc/Environmental Measurements & Controls Div**  
 500 Cardigan Road  
 Shoreview, MN 55126  
 Phone: 612-490-2888  
 Natl: 800-876-9874  
 Fax: 612-490-2874

**Tank Industry Consultants Inc**  
 4912 W 16th St, PO Box 24359  
 Speedway, IN 46224  
 Phone: 317-244-3221  
 Fax: 317-468-7068

**Tarby of Delaware**  
 2205 E L Anderson Blvd  
 Claremore, OK 74017  
 Phone: 918-341-8282  
 Natl: 800-854-1879  
 Fax: 918-341-8297

**Taylor Technologies**  
 31 Loveton Circle  
 Sparks, MD 21152  
 Phone: 410-472-4340

Natl: 800-837-8548  
 Fax: 410-771-4291  
**Technotreat Corp**  
 6216 S Lewis Ave No. 106  
 Tulsa, OK 74136-1017  
 Phone: 918-742-5052  
 Fax: 918-742-5585

**Tedder & Widhelm Consultants Inc**  
 3620 Rittenhouse Ct  
 Marietta, GA 30062-5945  
 Phone: 404-973-5826  
 Fax: 404-578-8410

**Tel-Tru Mfg Co**  
 408 St Paul St  
 Rochester, NY 14605  
 Phone: 716-232-1440  
 Natl: 800-232-5335  
 Fax: 716-232-3857

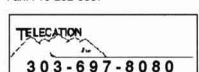

**Telecom Inc**  
 19423 N Turkey Creek  
 Morrison, CO 80465  
 Phone: 303-697-8080  
 Fax: 303-697-8085

**Teledyne Brown Engineering - Control Applications**  
 2929 N Central Expressway  
 Richardson, TX 75080  
 Phone: 214-437-7779  
 Fax: 214-437-7712

**Teledyne Brown Engineering/Analytical Instruments**  
 16830 Chestnut St  
 Industry, CA 91749  
 Phone: 818-961-9221  
 Fax: 818-961-2538

**Teledyne Brown Engineering**  
 15520 Cornet Ave  
 Westwood, NJ 07675  
 Phone: 201-664-7070  
 Natl: 800-666-0222  
 Fax: 201-664-5886

**Telikamp Systems Inc**  
 15520 Cornet Ave  
 Santa Fe Springs, CA 90670  
 Phone: 310-802-1621  
 Fax: 310-802-1303

**Telog Instruments Inc**  
 PO Box 240  
 West Henrietta, NY 14586  
 Phone: 716-359-1110  
 Fax: 716-359-9401

**Temcor**  
 24724 S Wilmington Ave  
 Carson, CA 90745  
 Phone: 310-889-4911  
 Natl: 800-421-2263  
 Fax: 310-549-4588

**Temtec Inc/TEMPhadge**  
 100 Route 59  
 Suffern, NY 10901-4910  
 Phone: 814-368-4040  
 Natl: 800-628-0022  
 Fax: 914-368-4099

**Tenax Corp**  
 4800 E Monument St  
 Baltimore, MD 21205  
 Phone: 410-522-7000  
 Natl: 800-356-8495  
 Fax: 410-522-7015

**Tenco Hydro Inc**  
 4620 Forest Ave  
 Brookfield, IL 60513-2594  
 Phone: 708-387-0700  
 Fax: 708-387-0732



**TENERX CORP.**  
**713-482-5801**

**Tenex Corp**  
 PO Box 1444  
 Friendswood, TX 77546-1444  
 Phone: 713-482-5801

**Terra Bio Chem Environmental & Engineering Services Inc**  
 276 Route 206  
 Andover, NJ 07821  
 Phone: 201-426-0800  
 Fax: 201-426-0808

**Terra Consulting Corp**  
 8900 Anselmo Lane  
 Baton Rouge, LA 70810  
 Phone: 504-769-1141  
 Fax: 504-769-1724  
**SEE AD ON PAGE 35, 36**

**Terra Universal**  
700 N Harbor Blvd  
Anaheim, CA 92805  
Phone: 714-526-0100

**Terra Consulting Corp**  
8900 Anzelmo Lane  
Baton Rouge, LA 70810

**Texas Engineering**  
Extension Service  
Texas A & M University System  
College Station, TX 77843-8000  
Phone: 409-845-3418  
Natl: 800-252-2420  
Fax: 409-845-3419

**The Mar Co**  
134 W Fifth St  
Lansdale, PA 19446-2439  
Phone: 215-362-2998  
Natl: 800-322-9347  
Fax: 215-362-2998

**Thermo Environmental**  
Instruments  
8 W Forge Parkway  
Franklin, MA 02038  
Phone: 508-520-0430  
Fax: 508-520-1460

**Thermoplastic Processes Inc**  
1268 Valley Road  
Stirling, NJ 07980  
Phone: 908-561-3000  
Fax: 908-753-6749

**Thermotron**  
291 Koller Park Drive  
Holland, MI 49423  
Phone: 616-393-4580  
Fax: 616-392-5643

**Thomas Products Limited**  
987 West St  
Southington, CT 06489-1023  
Phone: 860-713-9101  
Natl: 800-666-9101  
Fax: 203-621-1470

**Thornton Associates Inc**  
1432 Main St  
Waltham, MA 02154  
Phone: 617-890-3939  
Natl: 800-642-4418  
Fax: 617-890-5507

**3M**  
Bldg 207-1W-11 3M Center  
St Paul, MN 55144  
Phone: 612-733-1986  
Natl: 800-328-1687  
Fax: 612-736-1237

**3M Filtration Products**  
3M Center Bldg 275-6E-08  
St Paul, MN 55144-1000  
Phone: 612-733-9733  
Natl: 800-648-3533  
Fax: 612-733-9525

**Time Applications & Electronics**  
828 Crown Point Ave  
Omaha, NE 68110  
Phone: 402-453-7958  
Fax: 402-453-2358

**Time Mark Corp**  
11440 E Pine St  
Tulsa, OK 74116-2098  
Phone: 918-438-1220  
Natl: 800-862-2875  
Fax: 918-437-7584

**Tnemec Co Inc**  
6800 Corporate Drive  
Kansas City, MO 64120-1372  
Phone: 816-483-3400  
Fax: 816-483-3969

**Total Containment Inc**  
PO Box 939  
Oaks, PA 19456  
Phone: 610-666-7777  
Fax: 610-666-5321

**Tracer Research Corporation**  
1-800-394-9929

**Tracer Research**  
3855 N Business Center Drive  
Tucson, AZ 85705  
Phone: 602-888-9400  
Natl: 800-394-9929  
Fax: 602-293-1306

**Tracom Inc**  
PO Box 1519  
Roswell, GA 30077  
Phone: 404-664-6513  
Fax: 404-664-6906

**Trans-Enviro Inc**  
19701 S Miles Road  
Warrensburg Heights, OH 44128  
Phone: 216-663-0808  
Natl: 800-969-0808  
Fax: 216-663-0656

**Transducer Research**  
999 E Chicago Ave  
Naperville, IL 60540-5509  
Phone: 708-357-0004  
Fax: 708-357-1055

**Transport Law Research Inc**  
57 North St. No. 313  
Danbury, CT 06810  
Phone: 203-830-4018  
Fax: 203-830-4015

**Traverse Group, The**  
3772 Plaza Drive  
Ann Arbor, MI 48108  
Phone: 313-747-9300  
Fax: 313-747-9229

**Treatment Technologies**  
584 Poplar Road  
Honey Brook, PA 19344  
Phone: 610-273-2977  
Fax: 610-286-6145

**Tri-Mer Corp**  
1400 Monroe St  
Owosso, MI 48867  
Phone: 517-723-7833  
Fax: 517-723-7344

**TRI-RINSE™**

**Tri-Rinse Inc**  
5200 Manchester Road  
St. Louis, MO 63110  
Phone: 314-647-8338  
SEE AD ON PAGE 3

**Triangle Laboratories Inc**  
6320 Quadrangle Drive  
Chapel Hill, NC 27514  
Phone: 919-493-1848  
Fax: 919-493-5545

**Trilogy Controls Inc**  
505 E Evelyn Ave  
Mountainview, CA 94041  
Phone: 415-967-5571  
Fax: 415-961-5949

**Trinity Consultants Inc**  
12801 N Central Expy No. 1200  
Dallas, TX 75243  
Phone: 214-661-8100  
Fax: 214-385-9203

**Trinity Environmental Technologies**  
62 E First St  
Mound Valley, KS 67354  
Phone: 316-328-3222  
Natl: 800-722-8378  
Fax: 316-328-2033

**Trion Inc**  
101 McNeill Road  
Sanford, NC 27330  
Phone: 919-775-2201  
Natl: 800-421-3956  
Fax: 919-774-8771

**Turner Designs**  
845 W Maude Ave  
Sunnyvale, CA 94086-2911  
Phone: 408-749-0994  
Fax: 408-749-0998

**Turner EnviroLogic Inc**  
3439 SW 11th St  
Deerfield Beach, FL 33442  
Phone: 305-422-9787  
Fax: 305-422-9723

**21 EM/Eticam**  
25 Graystone St  
Warwick, RI 02886  
Phone: 401-738-3261  
Natl: 800-541-8673  
Fax: 401-738-1073

**TVMC**  
PO Box 2368  
Waco, TX 76703-2368  
Phone: 817-799-5546  
Natl: 800-258-9626  
SEE AD ON PAGE 65

**TYMCO Inc**  
PO Box 2368  
Waco, TX 76703-2368  
Phone: 817-799-5546  
Natl: 800-258-9626  
SEE AD ON PAGE 65

**United Capitol Insurance Co**  
1400 Lake Hearn Drive  
Atlanta, GA 30319  
Phone: 404-843-5599  
Fax: 404-843-5598

**U C Berkeley Extension-  
Environmental Mgmt**  
2223 Fulton St  
Berkeley, CA 94720  
Phone: 510-843-7143  
Fax: 510-643-8290

**U-Fuel Inc**  
PO Box 1511  
Eau Claire, WI 54702  
Phone: 715-836-0905  
Fax: 715-836-9993

**USI**  
310-802-9688

**U S Industrial Products Co Inc**  
13926 Equitable Road  
Cerritos, CA 90703  
Phone: 310-802-9688

**US Filter Corp**  
61 Thorn Hill Road  
Warrandale, PA 15086  
Phone: 412-772-0044  
Natl: 800-525-0658  
Fax: 412-772-1360

**USPCI**  
515 W Greens Road No. 500  
Houston, TX 77067-4524  
Phone: 713-775-7800  
Natl: 800-877-2401  
Fax: 713-775-7910

**Ultra Scientific Inc**  
250 Smith St  
North Kingstown, RI 02852  
Phone: 401-294-9400  
Natl: 800-338-1754  
Fax: 401-295-2330

**Ultratech International**  
1171-2 Phillips Hwy  
Jacksonville, FL 32256  
Phone: 904-292-1611  
Natl: 800-353-1611  
Fax: 904-292-1325

**Unidata America**  
17408 Boonies Ferry Road  
Lake Oswego, OR 97035-5220  
Phone: 503-697-3570

**Unifilt**  
118 North Main St  
Zellenople, PA 16063  
Phone: 412-452-5008

**Unimetrics**  
501 Earl Road  
Shorewood, IL 60436  
Phone: 815-741-1370  
Natl: 800-854-6931  
Fax: 815-741-0799

**U**  
1-800-323-8647

**Unipure Environmental**  
151 E Orangeville Ave  
Fullerton, CA 92630  
Phone: 714-525-9225  
Fax: 714-525-5158  
SEE AD ON PAGE 10

**Unisorb Corp.**  
713-943-3753

**Unisorb Corp**  
PO Box 388  
South Houston, TX 77587  
Phone: 713-943-3753  
Fax: 713-943-7313

**United Air Specialist**  
4440 Creek Road  
Cincinnati, OH 45242  
Phone: 513-891-0400  
Natl: 800-992-4422  
Fax: 513-891-4882

**United Capitol Insurance Co**  
1400 Lake Hearn Drive  
Atlanta, GA 30319  
Phone: 404-843-5599  
Fax: 404-843-5598

**United Environmental  
Coverage Corp**  
16-00 Pollitt Drive  
Fair Lawn, NJ 07410  
Phone: 201-797-6600  
Fax: 201-797-4455

**United McGill Corp**  
One Mission Park  
Groveport, OH 43125

Phone: 614-836-9981  
Fax: 614-836-9843

**United States Inc**  
510 N Pioneer Road  
Gibsonia, PA 15044  
Phone: 412-443-8610  
Fax: 412-443-7180

**United States Filter Corp**  
PO Box 560, 4669 Shepherd Trail  
Rockford, IL 61105  
Phone: 815-877-3041  
Fax: 815-877-0172

**United States Filter Corp**  
181 Thorn Hill Road  
Warrendale, PA 15086  
Phone: 412-772-0044  
Natl: 800-525-0658  
Fax: 412-772-1360

**Universal Engineering**  
800 First Ave Northwest  
Cedar Rapids, IA 52405  
Phone: 319-365-0441  
Fax: 319-369-5440

**Universal Enterprises Inc**  
5500 SW Arctic Drive  
Beaverton, OR 97005  
Phone: 503-644-8723  
Natl: 800-547-5740  
Fax: 503-643-6322

**Universal Process Equipment Inc**  
PO Box 338  
Rossville, NJ 08555-0338  
Phone: 609-443-4545  
Fax: 609-259-0644

**Universal Sensors & Devices Inc**  
9205 Alabama Ave Unit C  
Chatsworth, CA 91311  
Phone: 818-998-7121  
Natl: 800-899-7121  
Fax: 818-998-7147

**University of Florida  
TREEO Center**  
3900 SW 63rd Blvd  
Gainesville, FL 32608-3848  
Phone: 904-392-9570  
Fax: 904-392-6910

**Utilicom Inc**  
7 Tobey Village Office Park  
Pittsford, NY 14534  
Phone: 716-381-8710  
Natl: 800-926-6759  
Fax: 716-381-1614

**Uvex Safety LLC**  
10 Thurber Blvd  
Smithfield, RI 02917  
Phone: 401-232-1200  
Natl: 800-343-3411  
Fax: 401-232-1830

**V**  
**Vac-U-Max**  
37 Rutgers St  
Bellevue, NJ 07109  
Phone: 201-759-4600  
Natl: 800-289-8228  
Fax: 201-759-6449

**Vacuum Engineering**  
3374 W Hopkins St  
Milwaukee, WI 53216  
Phone: 414-444-4010  
Natl: 800-832-4010  
Fax: 414-449-9830

**Vaisala Inc**  
100 Commerce Way  
Woburn, MA 01801  
Phone: 617-933-4500  
Fax: 617-933-8029

**Valley Vids**  
2660 Horizon Drive Southeast  
Grand Rapids, MI 49546  
Phone: 616-949-4343  
Natl: 800-842-0466  
Fax: 616-949-5720

**Valve Technology Co**  
PO Box 91121  
Portland, OR 97291-0121  
Phone: 503-690-8157  
Fax: 503-690-9529

**Vanco Engineering Group**  
3000 Langford Road No. 700  
Norcross, GA 30071-1521  
Phone: 404-441-2729  
Fax: 404-246-9885

**Vara Intl Div of Calgon  
Carbon Corp**  
1201 19th Place  
Vero Beach, FL 32960  
Phone: 407-567-1320

Fax: 407-567-4108

**Varian Instruments**  
Dept 87, PO Box 9000  
San Fernando, CA 91340  
Natl: 800-944-1826

**Vaughn Co Inc**  
364 Monte Elma Road  
Montesano, WA 98563-9798  
Phone: 206-249-4042  
Fax: 206-249-6155

**Vector Technologies Ltd**  
3374 W Hopkins St  
Milwaukee, WI 53216  
Phone: 414-444-4010  
Natl: 800-832-4010  
Fax: 414-449-2628

**Veeder-Root Co**  
125 Powder Forest Drive  
Simsbury, CT 06070-2003  
Phone: 203-651-2700  
Fax: 203-651-2719

**Versar Inc**  
6850 Versar Center  
Springfield, VA 22151  
Phone: 703-750-3000  
Natl: 800-283-7727  
Fax: 703-642-6807

**Vertek**  
RR 1 Box 120A Waterman Road  
South Roylton, VT 05068  
Phone: 802-763-8348  
Natl: 800-639-6315  
Fax: 802-763-8283

**Vibra Screw Inc**  
755 Union Blvd  
Totowa, NJ 07511  
Phone: 201-256-7410

**Vitel Inc**  
14110 Parke Long Court  
Chantilly, VA 22021  
Phone: 703-968-7575  
Fax: 703-968-7581

**W**  
**W I Gore & Associates Inc**  
101 Lewisville Road  
Elkton, MD 21921  
Phone: 410-392-3300  
Fax: 410-398-6624

**W R Grace - Grace Emission  
Control**  
12300 Winrock Road  
Hiram, OH 44234  
Phone: 216-569-3245  
Fax: 216-569-7636

**WESCO Mfg Co**  
PO Box 47  
Lansdale, PA 19446  
Phone: 215-699-7031  
Natl: 800-346-5511  
Fax: 215-699-3836

**Waid & Associates**  
14205 Burnet Road No. 500  
Austin, TX 78729  
Phone: 512-255-9999  
Fax: 512-255-8780

**Walk, Haydel & Associates Inc**  
600 Carondelet St  
New Orleans, LA 70130  
Phone: 504-586-8111  
Fax: 504-522-0554

**WALLACE & TIERNAN®**  
201-759-8000

**Wallace & Tierman Inc**  
25 Main St  
Bellevue, NJ 07109-3057  
Phone: 201-759-8000  
Fax: 201-759-0348

Chlorination Equipment; Chlorine Detectors; Disinfection Equipment; Water Feeders; Flowmeters; Variable Area; Gas Detectors; Leak Detectors; Lime Slakers; Packaged Treatment Plants; Polymer Blending/Feeding Systems; Sulfur Dioxide; Sulfur Oxide Detectors; Wastewater Treatment Systems; Water/Wastewater Treatment Equipment

SEE AD ON PAGE 29

**Warren Rupp Inc A Unit of IDEX**  
800 N Main St, Box 1568  
Mansfield, OH 44901  
Phone: 419-524-8388  
Fax: 419-522-7867

**Waste Stream Technology Inc**

302 Grote St  
Buffalo, NY 14207  
Phone: 716-876-5290  
Fax: 716-876-2412

**Water-Tech Inc**  
1931 Industrial Drive  
Libertyville, IL 60048  
Phone: 708-367-5150  
Fax: 708-367-1787

**Water Equipment Tech**  
832 Pike Road  
West Palm Beach, FL 33411-3855  
Phone: 407-684-6300  
Natl: 800-684-4844  
Fax: 407-697-3342

**Water Inc**  
242 W Main St Unit No. 263  
Hendersonville, TN 37075  
Phone: 615-264-0060  
Fax: 615-264-0070



**Water Specialties Corp**  
191 W Poplar Ave  
Porterville, CA 93257  
Phone: 209-784-3544  
Fax: 209-784-1787

**Watersaver Co Inc**  
PO Box 16465  
Denver, CO 80216-0465  
Phone: 303-289-1818  
Natl: 800-525-2424  
Fax: 303-287-3136

**Waukesha Fluid Handling**  
611 Sugar Creek Road  
Delavan, WI 53115-1337  
Phone: 414-729-1900  
Natl: 800-252-5200  
Fax: 414-728-4320

**Wavetek Corp**  
9045 Balboa Ave  
San Diego, CA 92123  
Phone: 619-279-2200  
Natl: 800-854-2708  
Fax: 619-450-0325

**Weather Metrics Inc**  
PO Box 7071  
Shawnee Mission, KS 66207  
Phone: 913-384-9666  
Natl: 800-869-8629  
Fax: 913-384-2666

**Weinman Pumps (Div of Crane Pumps & Systems Inc)**  
420 Third St, PO Box 603

Piqua, OH 45356  
Phone: 513-773-2442  
Fax: 513-773-2238

**Wellington Environmental Consulting & Construction Inc**  
607 Hanley Industrial Court  
St Louis, MO 63144  
Phone: 314-644-4930  
Fax: 314-644-6744



**Western Filter Co**  
PO Box 16323  
Denver, CO 80216  
Phone: 303-288-2617  
Fax: 303-286-9328

**Westinghouse Motor Co**  
IH-35 & Westinghouse Road  
PO Box 2777  
Round Rock, TX 78681  
Phone: 512-255-4141  
Natl: 800-451-8798  
Fax: 512-244-5500

**Whatman Inc**  
9 Bridewell Place  
Clifton, NJ 07014  
Phone: 201-773-5800  
Natl: 800-922-0361  
Fax: 201-472-6949

**Wheaton Science Products**  
1000 N 10th St  
Millville, NJ 08332  
Phone: 609-825-1100  
Natl: 800-225-1437  
Fax: 609-825-1368

**Wheelabrator Air Pollution Control**  
441 Smithfield St  
Pittsburgh, PA 15222  
Phone: 412-562-7300  
Fax: 412-562-7617

**Wheelabrator Clean Water Systems Inc/Bio Gro Div**  
180 Admiral Cochrane Drive No. 305  
Annapolis, MD 21401  
Phone: 410-224-0022

**Wheelabrator Engineered Systems Inc - Memtek Products**  
28 Cook St  
Billerica, MA 01821  
Phone: 508-667-2828  
Natl: 800-527-0433  
Fax: 508-667-1731

**Wheelabrator Environmental Systems Inc**

55 Shuman Blvd  
Naperville, IL 60563  
Phone: 708-357-7330  
Fax: 708-717-2247

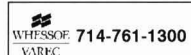

**Whessoff Vario**  
10800 Valley View St  
Cypress, CA 90630  
Phone: 714-761-1300



**White Horse Technologies Inc**  
2450 - 135th Ave NW  
Minneapolis, MN 55304  
Phone: 612-783-9980  
SEE AD ON PAGE 33

**Wilkins-Anderson Co**  
4525 W Division St  
Chicago, IL 60651  
Phone: 312-384-4433  
Natl: 800-847-2222  
Fax: 312-384-6260



**Williams Knowledge Systems Inc**  
One Williams Center  
Tulsa, OK 74172  
Phone: 918-588-3187  
Natl: 800-324-2744  
SEE AD ON PAGE 9

**Winsor & Jerauld**  
1525 Old Louisiquisset Dr  
Lincoln, RI 02865  
Phone: 401-727-4480  
Fax: 401-727-4483

**Wisconsin Protective Coat**  
PO Box 8147  
Green Bay, WI 54308-8147  
Phone: 414-437-6561  
Fax: 414-437-8083

**Wolfco Group Inc**  
7553 Clover Ave  
Mentor, OH 44060-5206  
Phone: 216-953-1115  
Natl: 800-227-9563

**Wolverine (Massachusetts) Corp**  
1861 Nimitz Drive, PO Box 521  
De Pere, WI 54115

Phone: 414-336-5231  
Fax: 414-336-5360

**Wonder Makers Inc**  
PO Box 50209  
Kalamazoo, MI 49005-0209  
Phone: 616-382-4154  
Fax: 616-382-4161

**World Environment Center**  
419 Park Ave South No. 1800  
New York, NY 10016  
Phone: 212-683-4700  
Fax: 212-683-5053

**Wysmont**  
PO Box 1397  
Fort Lee, NJ 07024-1397  
Phone: 201-947-4600  
Fax: 201-947-0324



**X-Pando Products Co**  
500 Southard St  
Trenton, NJ 08638  
Phone: 609-394-0150  
Fax: 609-989-4847

**Xchanger Inc**  
1401 S Seventh St  
Hopkins, MN 55343  
Phone: 612-933-2559  
Fax: 612-933-5647

**Xomox Corp**  
4444 Cooper Road  
Cincinnati, OH 45242  
Phone: 513-745-6000  
Fax: 513-745-6972



**YSI Inc**  
PO Box 279  
Yellow Springs, OH 45387-0279  
Phone: 513-767-7241  
Natl: 800-765-4974  
Fax: 513-767-9353

**Yellow Logistics Services Inc**  
10770 El Monte  
Overland Park, KS 66211  
Phone: 913-967-4999  
Natl: 800-967-4959  
Fax: 913-967-4949

**Youngstown Barrel & Drum Co**  
1043 Marble St  
Youngstown, OH 44501  
Phone: 216-746-3277  
Natl: 800-359-3786  
Fax: 216-746-3288



**Zero Enclosures**  
200 North 50th West  
North ait Lake, UT 80454  
Phone: 801-298-5900  
Fax: 801-292-9450  
SEE AD ON PAGE 38

**Ziomatic Corp**  
10 W College Ave, PO Box 337  
Yardley, PA 19067-0587  
Phone: 215-493-3618  
Fax: 215-493-1401

**Zimmerman Industries Inc**  
196 Wabash Road  
Ephrata, PA 17522-9662  
Phone: 717-733-6166  
Fax: 717-733-1169

**Zimpro Environmental Inc**  
301 W Military Road  
Rothschild, WI 54474-1944  
Phone: 715-359-7211  
Natl: 800-826-1476  
Fax: 715-355-3219

**Zink, John Co Div of Koch Engineering Co Inc**  
11920 E Apache  
Tulsa, OK 74116  
Phone: 918-234-1800  
Fax: 918-234-2700



**Zurich Insurance**  
1400 American Lane  
Schaumburg, IL 60196  
Phone: 708-805-6000  
SEE AD ON PAGE 104, 105

**Zurn Industries, Air Systems Div**  
PO Box 2206  
Birmingham, AL 35201-2206  
Phone: 205-942-2211  
Fax: 205-942-0004

**Does your company's name appear in the JANUARY 1995 ENVIRONMENTAL PROTECTION BUYER'S GUIDE?**

To make sure your company is represented in the pages of the **1996 Environmental Protection Buyer's Guide**, fill out the coupon below so we can send you next year's questionnaire.

**YES!**

We want to be listed in your 1996 Buyer's Guide. Add our name to your list to receive a FREE LISTING questionnaire.

Mail to : ENVIRONMENTAL PROTECTION P.O. BOX 2573, Waco, TX 76702-2573 (817) 776-9000; FAX (817) 776-9018 Attn: Sourcebook Coordinator

Contact Person \_\_\_\_\_

Company \_\_\_\_\_

Address \_\_\_\_\_

City \_\_\_\_\_ State \_\_\_\_\_ Zip \_\_\_\_\_

Phone \_\_\_\_\_ Fax \_\_\_\_\_

# The source for diverse air quality needs.

## Names you know us by.

The technologies and products we offer include services, trademarks and trade names such as.



Altech 120 CEM™  
Altech 180 CEM™  
Standard CEMs

## Amceec

Amceec MICROBLOC  
Amceec MONOBLOC  
Amceec EcoVap™  
Amceec Hybrid Concentrator



ARI Econ-Abator®  
ARI Econ-NOx™  
ARI LO-CAT®  
ARI LO-CAT II®



Huntington Energy Systems RTO  
(HES/RTO™ System)



Concrete Chimneys and Storage Silos



Westates AQUA-SCRUB™  
Westates Biocarb™  
Westates BRU  
Westates Carbon Equipment  
Westates Carbon Reactivation  
Westates Carbon Services  
Westates VENT-SCRUB™



Fabric Filters (JETIII®; DUSTUBE®)  
Electrostatic Precipitators (HaRDE®)  
Flue Gas Conditioning  
Wet and Dry Scrubbers  
NO<sub>x</sub> Emissions Control

© 1994 Wheelabrator Clean Air Systems Inc.

We have brought together leading air quality companies with a full range of custom- and pre-engineered emission control and measurement options. With proven systems and technologies in:

### VOC Control

- Carbon Adsorption
- Thermal Oxidation
- Biofiltration
- Air Stripping
- Condensation

### Sulfur Recovery/Odor Control

- Carbon Adsorption
- Catalytic Oxidation
- Air Stripping

### Solvent Recovery

- Carbon Adsorption
- Condensation
- Distillation

### Particulate Control

- Electrostatic Precipitation
- Fabric Filtration
- Mechanical Collection

### Acid Gas Control

- Wet FGD Scrubbing
- Spray Dryer Scrubbing
- Dry Injection

### Emission Monitoring and Measurement

- Hot/Wet or Cold/Dry CEM
- Single or Multiple Component

### Concrete Structures and Aftermarket Services

- Design and construction of reinforced concrete chimneys and storage silos
- Inspection, maintenance and repair

### Carbon Products & Services

- Carbon Equipment
- Carbon Replacement
- Carbon Reactivation

No other air quality company provides so many cost-effective solutions.

### Turnkey systems, tailored to your needs.

We provide initial problem analysis and comparative cost-benefit evaluations, complete system design, construction and testing; system installation and start-up, personnel training and ongoing service support.

Our Industry Solution Teams provide real-world process know-how and firsthand insights that assist you to quickly and accurately assess all options for emission control and measurement.

As a result, you can rely on guaranteed, warranted systems designed to keep you in compliance.

Delivered on time, and within budget.



*Wheelabrator Clean Air Systems Inc.*

A WHEELABRATOR TECHNOLOGIES COMPANY

**Circle 3 on card.**

1501 East Woodfield Road, Suite 200 West  
Schaumburg, IL 60173  
708/706-6900 • Fax 708/706-6996

# PRODUCT LITERATURE

## Reader Service

To receive information or find out more on any of the product literature featured on this page, circle the appropriate number on the enclosed reader service card or call the company directly.



### Hydrocarbon Removal

Reclaim passive remediation canisters recover BTEX and other organics from groundwater at low cost, over wide concentration range. Recyclable canisters, provided on a service basis, remove product sheens, dissolved phase and sinking hydrocarbons from groundwater. They are effective in high or low permeability soils. EFSI fingerprints and reports on organics recovered in process.

**Environmental Fuel Systems Inc.**  
(800) 375-7747; Fax: (210) 796-7484

Circle 148 on card.



### Airborne Ground Penetrating Radar

This brochure highlights the benefits and applications of Airborne Ground Penetrating Radar that can detect subsurface objects and map plumes of refined hydrocarbons. This system is truly an underground vision that provides an economical alternative for conducting site assessments.

**Airborne Environmental Surveys**  
3130 Skyway Drive, Suite 108  
Santa Maria, CA 93455  
(800) 331-0960; (805) 922-9152

Circle 145 on card.



### Instruments Catalog

The free 1995-96 instruments catalog contains over 1,700 full-color pages and features more than 40,000 products covering scientific instruments, equipment and supplies. It includes a detailed 40-page product index, informative introductory pages for several sections, "Hot Tips" and an 8-page section of late-breaking products.

**Cole-Parmer Instrument Co.**  
7425 N. Oak Park Ave.  
Niles, IL 60714  
(800) 323-4340

Circle 149 on card.



### Monitoring Systems

We carry an extensive line of gas monitors for the detection of combustible gases, toxic gases and oxygen-deficient atmospheres. Our products range from small portable monitors to expansive, multi-point systems that alert workers of potentially hazardous conditions. The STM2100 is the next generation of products designed for safety.

**GasTech**  
8707 Central Ave.  
Newark, CA 94560  
(510) 745-1275

Circle 146 on card.



### Vapor Recovery Systems

Remove up to 95 percent of solvent vapors from process vessels, vent lines and tank exhaust collection systems. An optimal refrigerated vapor recovery design can achieve economical benefits and meet Best Available Control Technology requirements by reprocessing or collecting hydrocarbon vapors.

**Morehouse-COWLES**  
1600 W. Commonwealth Ave.  
Fullerton, CA 92633  
(714) 738-5000  
Fax: (714) 738-5960

Circle 150 on card.

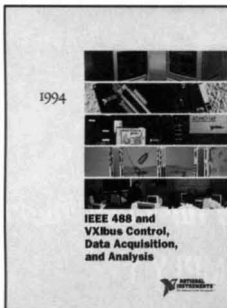

### DAQ Software Tool

DAQ Designer is a free software tool that helps determine which hardware software combinations are best for your PC-based data acquisition system.

**National Instruments**  
6504 Bridge Point Parkway  
Austin, TX 78730  
(512) 794-0100  
(800) 433-3488  
Fax: (512) 794-8411

Circle 147 on card.



### Earthprobe 200

This self-contained all hydraulic rig meets the growing demand for direct push/probing technology for taking soil, water or vapor samples. The Earthprobe 200 is ruggedly built and can be mounted in any suitably sized pickup truck. Advanced hydraulics allow precise control over the feed and hammering functions. The mast tilts for angle probing. The optional rotary head provides limited auger drilling capability.

**SIMCO**  
(800) 338-9925

Circle 151 on card.

# 1994 EDITORIAL INDEX



## Aboveground Storage Tanks

- "Secondary Containment Reduces Liability," by Lisa K. Neal, February 1994, p. 43.
- "Leak Prevention Critical For ASTs," by Bill Edwards, August 1994, p. 22.

## Air Pollution Control

- "Is Solvent Recovery the Right Choice?" by M. John Ruhl, February 1994, p. 34.
- "Utilities Buy Into Emissions Trading," by Susan Millington Campbell and Andrew S. Holmes, March 1994, p. 12.
- "How To Measure Fugitive Emissions," by Charles E. Schmidt and Michelle Simon, April 1994, p. 47.
- "How to Conduct An Emissions Inventory," by Raymond J. Topazio, July 1994, p. 28.
- "Gearing Up for Enhanced Air Monitoring," by George Siple, August 1994, p. 37.
- "VOC, HAP Control Systems Compared," by Rod L. Pennington, September 1994, p. 56.
- "How To Design VOC Perimeter Plans," by John A. Wood, October 1994, p. 43.
- "Three Steps To Better VOC Management," by Mark Elmendorf, December 1994, p. 11.

## Auditing

- "Conducting Audits: A Client Checklist," by J. Wilson Hershey and M. Louise Hess, February 1994, p. 22.
- "Lender Audits May Yield Dividends," by Malcolm D. Griggs, February 1994, p. 48.
- "Audits And The Self-evaluative Privilege," by Thomas D. Lupo, February 1994, p. 52.
- "Designing Self-audits To Fit The Facility," by Paulette Mandelbaum, November 1994, p. 32.
- "Management Commitment, Legal Design Essential To Audit Success," by Cheryl Blaine, November 1994, p. 37.
- "Evaluating the Evaluators: Phase I Environmental Assessment," by Anthony J. Buonicore and W. Jerrold Samford, November 1994, p. 40.

## Bioremediation

- "Peroxygens Enhance Biological Treatment," by Michael R. Fagan, September 1994, p. 45.
- "Water-Soil Model Indicates Best Ratio For Cleanup," by K.Y. Li, Yuebo Zhang and Tian Xu, December 1994, p. 28.

This spill contained courtesy of New Pig.

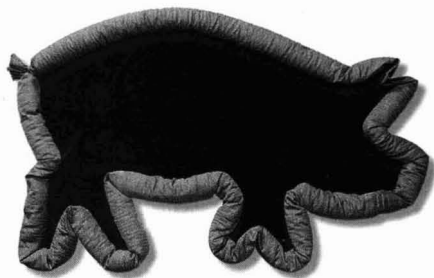

Our mission is to contain leaks and spills at your plant. No matter what their shape or size. We deliver innovative solutions that are guaranteed to make your plant cleaner,

safer and more productive. And you'll receive friendly, world-class service, too. Call New Pig Corporation.

1-800-HOT-HOGS®

 **New Pig**  
One Pork Avenue  
Tipton, PA 16684-0304

4161

Circle 90 on card.

**LOGICAL**  
TECHNOLOGY, INC.

**Environmental, Health & Safety Software**

- Hazardous materials management
- Materials & waste tracking
- Compliance reporting

**Comprehensive list-of-lists  
MSDS Services**

**The Logical Choice for Compliance**

1-800/COMPLY 1

5113 N. Executive Dr. • Peoria, IL 61614  
PH: (309) 689-2900 • FAX: (309) 689-2911

Circle 91 on card.



**Biosolids**

- "Companion Processes for Biosolids Use," by Tom Walsh, March 1994, p. 38.
- "Processing Biosolids For Market Value," by Jim Columbo and John Nelson, September 1994, p. 24.

**Clean Air Act**

- "Painting and Coatings Industry Faces Permitting Challenges," by John M. Hathaway, May 1994, p. 46.
- "Guidance For State Attainment Plans," by Randy Strait, June 1994, p. 30.
- "Air Compliance Falls Short Without CEMs," by George Wagner II, June 1994, p. 36.
- "Five Steps Toward Title V Permitting," by John Shrock, June 1994, p. 41.

**Clean Water Act**

- "Pretreatment Raises Biosolids Quality," by Gary Shimp, Kenyon Hunt, Suzanna McMillian and Gary Hunter, June 1994, p. 14.
- "Clean Water Bills Slow to Gain Favor," by Jim Pinkham, July 1994, p. 12.
- Guest Commentary, "Industry: Chlorine Use Is Beneficial," by Joseph Stearns, August 1994, p. 20.

**Compliance Issues**

- EPA Insight, "Guidance Documents Can Work For

You," by Richard Chatfield-Taylor, December 1994, p. 35.

- Guest Commentary, "Standard Solutions Fall Short Of Goal," by Charles S. Alpert, December 1994, p. 37.

**Consulting**

- 1994 Consultants' Guide, October 1994, p. 50.

**Drinking Water**

- "Dangerous Elements In Drinking Water," by Jim Pinkham, May 1994, p. 12.
- "Lead In Brass Pumps Drinking Water Risk," by Jay Lehr, June 1994, p. 61.
- "EPA Investigates Submersible Pumps/Lead Connection," by Dawn Drennan, June 1994, p. 63.

**Employment Issues**

- "Career Incentives, Salary Survey," by Lisa K. Neal, April 1994, p. 39.
- "Pollution Abatement Leads Job Market," by Peter J. Parks, April 1994, p. 42.
- "Looking For Work? What You Can Expect," by Michael Bruce, April 1994, p. 45.

**Groundwater**

- "Well Pump Critical For Proper Cleanup," by David L. Russell, September 1994, p. 38.

# EPA Regs On Disk For Pennies

Staying abreast of the latest EPA regulations is a snap with inexpensive **FASTREGS**® regulation management software. Available for Windows, Macintosh, DOS and CD-ROM!

**Instant Access.** Pick any word and in less than two seconds find every occurrence in the regs. Or use hyperlinks to unravel cross-references.

**Up-To-Date.** Make sure your regs are current with optional monthly or quarterly updates.

**For Pennies.** No other regulation scanning program comes close to matching the value of **FASTREGS** software. Higher performance for as little as 1/4 the cost of others!

**An Industry Standard.** Thousands of your colleagues are using **FASTREGS** software right now to keep up-to-date with changing regs!

Free demos available. Reseller inquires welcome.

Call for a Free Demo!  
800-446-3427

**ACHIEVE!**  
Technology, Inc.  
Formerly OSHA-Soft, Inc.

P.O. Box 668, Amherst, NH 03031-0668  
Fax: (603) 595-0088

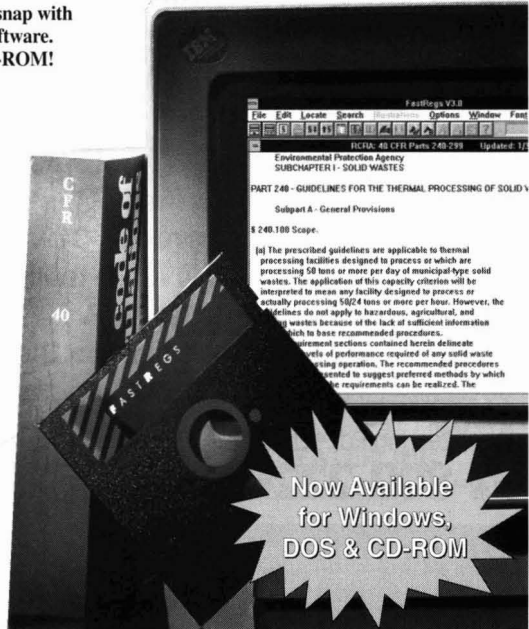

Now Available  
for Windows,  
DOS & CD-ROM

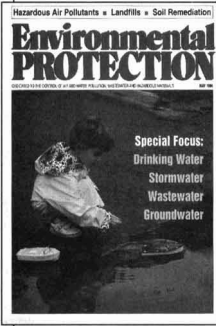

- Technology Answers, "'Lasagna' Process Treats Contaminants," by Dawn Drennan, September 1994, p. 69.
- "Improving Effectiveness of Pump And Treat," by Nancy A. Naslas, October 1994, p. 35.
- "Data Visualization for Groundwater," by Kevin Johnson, May 1994, p. 26.
- "Demystifying Issues In Statistical Groundwater Quality Tests," by Hao Chang, December 1994, p. 19.
- "Reallocating Water Rights," by Jean Bowman, December 1994, p. 20.

**Hazardous Materials**

- "Shippers Face New, Rigid Hazmat Rules," by Lauri Alvarez, October 1994, p. 26.

**Hazardous Waste**

- "Old Science Tapped For PCB Field Tests," by Craig McCaffrey and Tim Lawruk, July 1994, p. 36.

**Health Issues**

- "Environment, Health Link Needs Study," by Jonathan M. Ramlow, Geary W. Olsen and Gregory G. Bond, September 1994, p. 63.

**Incinerators**

- "Incineration Permits Demand New Tactics," by

Nicholas Pangaro, February 1994, p. 28.

- "Test Kit Testing Certifies Accuracy," by Lisa K. Neal, August 1994, p. 16.

**Insurance**

- "Insurance Options Expand For Contractors," by Mark Vuono, March 1994, p. 30.
- "Consulting Insurance," by Jim Pinkham, August 1994, p. 30.

**International Issues**

- Global Perspectives, "Environmental Heart Of NAFTA," by Whitman Bassow, January 1994, p. 12.
- Global Perspectives, "The Appeal Of ISO And World Standards," by Whitman Bassow, April 1994, p. 12.
- Global Perspectives, "Environmental Export Market Gets A Boost," by Whitman Bassow, July 1994, p. 10.
- Global Perspectives, "Visionary Predicts World Cooperation," by Whitman Bassow, August 1994, p. 10.
- Global Perspectives, "Bacon: A 16th Century Environmentalist," by Whitman Bassow, September 1994, p. 10.
- Guest Commentary, "French Firms Create New Eco-technologies," by Jean-Claude Oppeneau, October 1994, p. 19.
- Global Perspectives, "Cairo Links People, Problems,

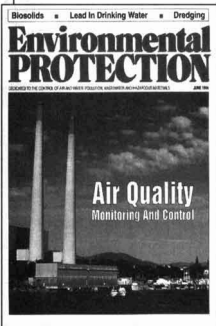

# Catastrophes Happen...But Not to ConVault!

Acts of nature like Hurricane Andrew, the San Francisco Earthquake, the great floods of the Mid-West...and man-made tragedies like a C-130 plane crash at an airbase in Georgia... have not interrupted the performance of ConVault AST's. In fact, more than 12,500 ConVault tanks have been installed without a single reported leak — no matter what hit them. No wonder ConVault's patented, UL-listed design sets the nation's standard for aboveground fuel storage.

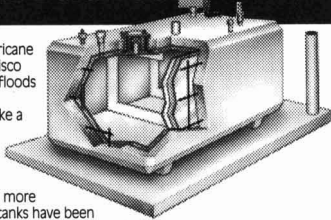

4109 Zeering Rd. • Denair, CA 95316  
**1-800-222-7099**

*20 Licensed Manufacturing and Service Centers in North America*

# HAZEN HAS THE EXPERIENCE!

- Sample Characterization \* Treatability Studies
- Bench-scale and Pilot-plant Demonstrations
- Process Design \* Consultation Services
- Physical and Chemical Separations
- Analytical Services \* Mineralogy
- Thermal Processing Studies

Hazen has provided these services to the mining, metallurgical, chemical, and environmental industries for over 30 years!

**Call NOW and put HAZEN to work for you**



**Hazen Research, Inc.**

4301 Indiana St.  
 Golden, CO 80403  
**(303)279-4501**  
 FAX (303)278-1528

*An Employee-Owned Company*



Solutions," by Whitman Bassow, November 1994, p. 10.

### Laboratory Issues

- "Lab Automation Augments Processing," by Kevin P. Kelly and David L. Stalling, February 1994, p. 12.
- "Mobile Lab Tests Soil At PPB Level," by Michael Purdy, February 1994, p. 20.
- "Study Questions Accuracy Of Accepted Gasoline Testing Methods," by Shakoora Azimi, February 1994, p. 24.
- "EPA Gathering Treatment Data," by Bruce A. Macler, May 1994, p. 22.
- "Scrubbing Efficient For Lab Emissions," by Kenneth Kumar, June 1994, p. 48.
- "Can Automation Make A Difference To Labs?" by William Pipkin, October 1994, p. 12.

### Landfills

- Technology Answers, "Landfill Wastes: A New Oil Well?" by Lisa K. Neal, January 1994, p. 30.
- "Tips for Profitable Landfill Acquisitions," by Ravi K. Nangunoori and Daniel P. Duffy, May 1994, p. 56.

### Legal Issues

- Practical Law, "Shielding Corporate Execs from Liability," by Gregor I. McGregor, March 1994, p. 52.
- Legal Watch, "Migrating Waste Poses New Liability," by Bert Black, May 1994, p. 61.
- Practical Law, "Culpability Proof Not Required By Law," by Gregor McGregor, June 1994, p. 45.
- Practical Law, "Assessing The Value Of 'Dirty' Property," by Gregor McGregor, September 1994, p. 74.
- "Is A Man's Castle Still His Business?" by M. Elizabeth McDaniel, November 1994, p. 12.
- Legal Watch, "High Court: Attorney Fees Not Recoverable," by Bert Black, November 1994, p. 44.
- Practical Law, "Be Prepared When You Take the Stand," by Gregor I. McGregor, December 1994, p. 17.

### Management

- Guest Commentary, "Recruits Need Not Wear Red Capes," by John Griffin, March 1994, p. 51.
- Global Perspectives, "Redesigning the Corporate Ladder," by Whitman Bassow, May 1994, p. 10.
- Global Perspectives, "CERES Principles Are Worth Exploring," by Whitman Bassow, June 1994, p. 8.

### Pollution Prevention

- Source Reduction, "California Promotes Stewardship, Efficiency," by David Weightman, February 1994, p. 11.
- Source Reduction, "Arizona Site Plans Reduce Waste Fees," by Linda Allen, April 1994, p. 56.
- Source Reduction, "Washington Eyes 50 Percent Decrease by 1995," by DeAnn Williams, June 1994, p. 66.
- "Trenchless Repair of Industrial Pipes," by

Kevin Vaughan, March 1994, p. 46.

### RCRA

- "New Treatment Rules Ease RCRA Disposal," by Edward L. Quevedo, March 1994, p. 22.

### Remediation

- "Comparing VOC Controls At Remediation Sites," by Linda L. Hunter, Victor S. Engleman and Stephen J. Priebe, January 1994, p. 40.

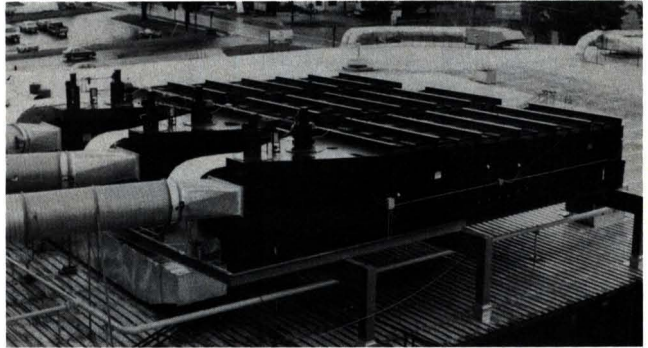

# OXIDIZER SYSTEMS

- ❑ **Combu-Changer® Regenerative Oxidizer**
- ❑ **Cor-Pak® Thermal & Catalytic Oxidizers**
- ❑ **99% VOC removal**
- ❑ **95% heat recovery**
- ❑ **ABB Air Preheater, Inc. - a world leader in VOC control equipment**
- ❑ **1100 installations worldwide since 1958**

# ABB

**ABB AIR PREHEATER, INC.**  
P. O. Box 372, Wellsville, NY 14895  
Phone: (716) 593-2700  
Fax: (716) 593-2721

- "DOD, DOE Clean-up Efforts Promising," by Diane Rose, January 1994, p. 58.
- "Reducing Aquifer Remediation Costs," by Robert D. Norris, January 1994, p. 66.
- "Solvent Extraction Processes Compared," by Kenneth E. Kogut, April 1994, p. 24.
- "Licenses Expedite Remedial Actions," by Neil Ram, April 1994, p. 30.
- "Bioreactor Boasts High BTEX Removal Rate," by Dr. Robert Hickey, April 1994, p. 32.
- "Spill Preparedness Is No Accident," by Kitty Shaffer and Douglas Rhodes, April 1994, p. 35.
- "Innovative Methods Speed Soil Cleanup," by Terrance G. Alexander, May 1994, p. 51.

#### Risk Assessment

- "Ecological Risk Assessment," by Cris Williams, January 1994, p. 56.
- Viewpoint, "Partnerships Vital for Risk Research," Kenneth Olden, January 1994, p. 28.
- Legal Watch, "EPA Proposes Risk Management Rules," by Bert Black, January 1994, p. 72.
- Guest Commentary, "Balancing Risk, Community Interest," by Brian J. Pinkowski, January 1994, p. 76.
- "Risk Assessment And Decision Making," by William Tucker, Claire Marcussen and Nichole Jurczyk, November 1994, p. 19.

#### Software

- 1994 Hazmat Software Guide, compiled by Dawn Drennan, March 1994, p. 24.
- 1994 Air Software Guide, compiled by Dawn Drennan, August 1994, p. 44.
- 1994 Water Software Guide, compiled by Dawn Drennan, September 1994, p. 30.
- 1994 Hazardous Waste Software Guide, compiled by Jane Flores, December 1994, p. 38.

#### Storage Tanks

- "Improving Tank Site Clean-up Assessments," by Michael Taylor, April 1994, p. 16.

#### Stormwater

- "Stormwater Funding," by Clarence H. Robbins and William E. Spearman, May 1994, p. 32.
- "How's And Why's Of Weather Monitoring," by D.E. Lehrman and William Knuth, June 1994, p. 24.

#### Superfund (CERCLA)

- "Water, Superfund Loom Large In '94," by Stevens Publishing News Bureau, January 1994, p. 16.
- Legal Watch, "Upton Bill Offers Clean-up Solutions," by Bert Black, July 1994, p. 22.
- "Superfund Reforms Emerge Without Congress," by Mark Dennison, November 1994, p. 26.

#### Training

- Environmental Training, "Developing Goals For Life-long Results," by Dawn Baldwin, January 1994, p. 14.
- Environmental Training, "Review Mode Holds Employee Attention," by Michael Cherniak, February 1994, p. 33.
- Environmental Training, "Hazmat Exceptions Cloud DOT Training," by Dawn Baldwin, March 1994, p. 36.
- Environmental Training, "Values - A Trainer Necessity, Not Nicety," by Michael Cherniak, April 1994, p. 58.
- Environmental Training, "Environment, Safety Meet on Training St.," by Dawn Baldwin, May 1994, p. 45.
- Environmental Training, "Laboratory Practice Makes Perfect Sense," by Michael Cherniak, June 1994, p. 12.
- Environmental Training, "Some Training Cannot Be Counted In Hours," by Dawn Baldwin, August 1994, p. 50.
- Environmental Training, "Dear John: Goodbye To Over-Regulation," by Michael Cherniak, September 1994, p. 53.
- Environmental Training, "The Audit: A Tool For Improvement," by Dawn Baldwin, October 1994, p. 16.
- Environmental Training, "No Better Time

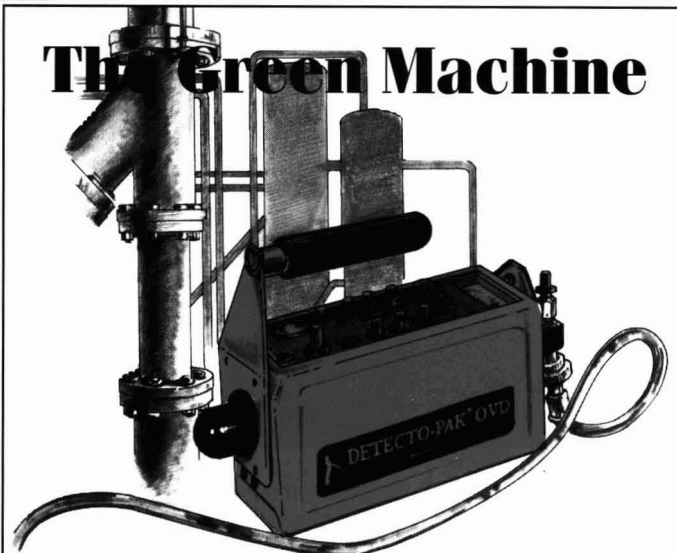

## The Green Machine

### Fugitive Emissions Testing

Heath is proud to introduce the all-new Detecto-Pak™ OVD, designed for the measurement of fugitive emissions and ideal for all VOC investigations.

The DP OVD has easily refillable fuel cylinders and uses a dependable, rechargeable long-life battery pack. Six sensitivity ranges detecting from 1 to 10,000 and up to 100,000 ppm with a built-in dilutor and a sampling pump for quick response, the DP OVD comes with a large analog meter and is provided with intrinsically safe connectors so that your dataloggers can be used.

- High quality
- Simple operation
- Lower cost
- Meets EPA Method 21 requirements
- Easier maintenance
- Intrinsically safe

For more information, call  
**800-HEATH US (432-8487)**



Heath Consultants Incorporated, 9030 Monroe Road, Houston, TX 77061  
Circle 96 on card.

## ENVIRONMENTAL INSURANCE

# Now more than ever, nobody covers the field like ECS and Reliance National.

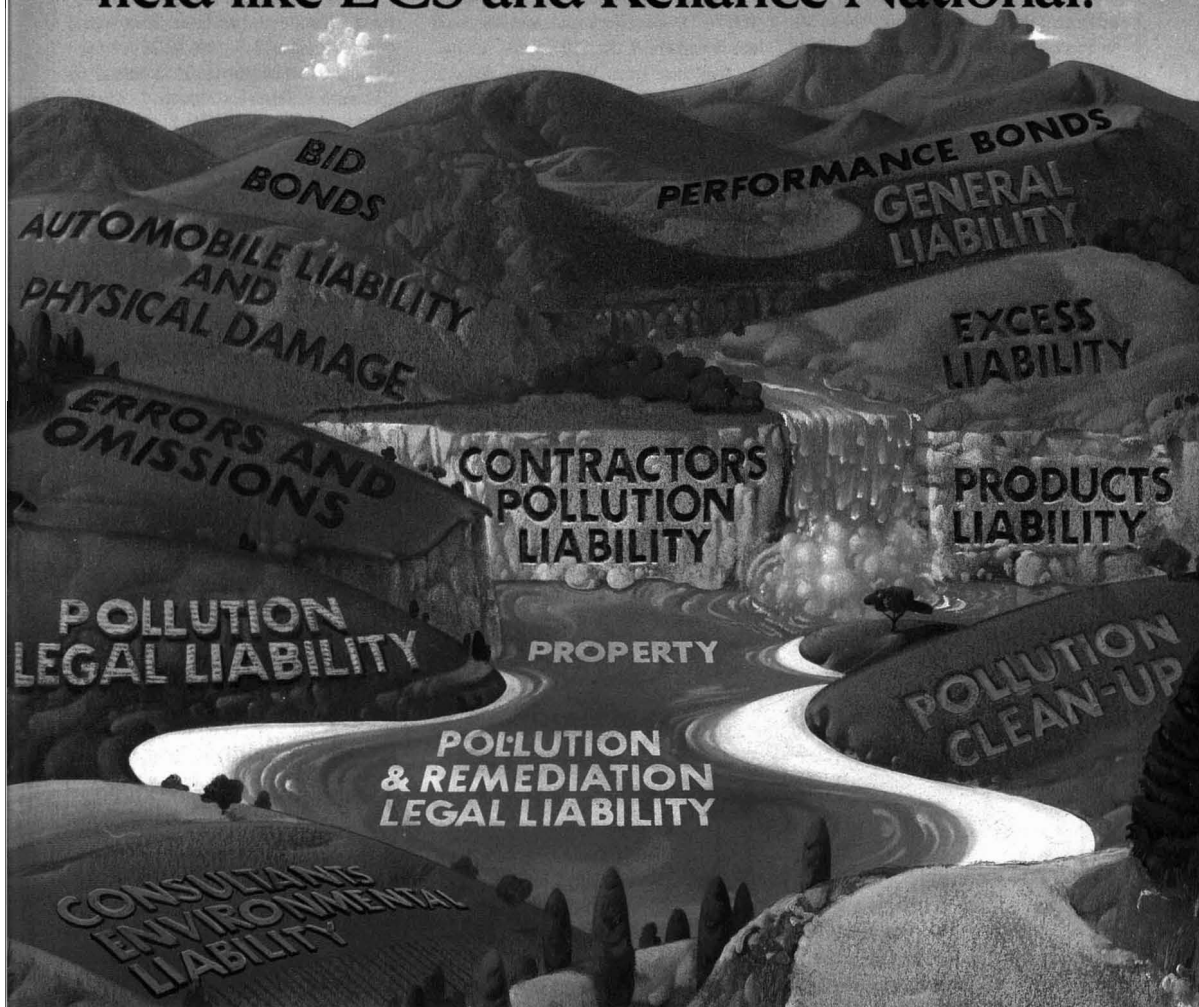

Since 1979 -- when ECS Underwriting practically pioneered the concept of environmental insurance -- new laws, standards, and areas of exposure have continued to crop up everywhere. ECS has responded -- innovating new programs that cover virtually every corner of environmental exposure. And we haven't stopped yet. Last year alone, we added new bid bonds and performance bonds ... and this year we are introducing the industry's first and only Pollution and Remediation Legal Liability Program\*, combining both first and third party pollution coverages into one efficient policy. In the future, you can count on ECS to develop new programs that protect industry worldwide ... backed by the most respected customer service in the industry. With immediate access to knowledgeable people who keep you covered and in compliance ... providing prompt, expert handling of every application, certification, and filing. So if you're

exploring the possibilities of environmental coverage, survey the field. Then come straight back to the source that started it all. Call ECS Underwriting at 1-800-ECS-1414. As always, offering the best environmental insurance coverage around.



**ECS**  
Underwriting  
Inc.  
*An ECS Company*

THE CHOICE  
**Reliance National**

**Circle 97 on card.**

*Environmental insurance protection for Worldwide industry.*

520 Eagleview Boulevard, P.O. Box 636, Exton, PA 19341. Or call (800) ECS-1414  
(In PA (610) 458-0570), FAX (610) 458-8667. 94-26-MP-08 © 1993 Code 9526INU01

These programs are underwritten by Reliance National Indemnity Company, Philadelphia, PA, a member of the Reliance Insurance Group.

\*Not available in all states at this time.

For Needs Assessment," by Michael Cherniak, November 1994, p. 17.

**Wastewater**

- "POTWs, Industry: Partners In Pre-treatment," by Ric Jensen, April 1994, p. 53.
- "Success With Supercritical Water Oxidation," by Ric Jensen, June 1994, p. 16.
- "Is Pump And Treat The Best Solution?" by J. Hilton Frey, Kathleen Shelton and Isidoros Zanikos, July 1994, p. 24.
- "EPA Issues Sewer Overflow Policy," by James T. Foil, September 1994, p. 12.
- "Wastewater Washing Screens Out Solids,"

- by David G. Mitchell, September 1994, p. 19.
- "Processing Biosolids For Market Value," by Jim Columbo and John Nelson, September 1994, p. 24.
- "Pretreatment Rules Impact Industry, POTWs," by Gary Hunter, Edmund Kobylinski and Gerard Miller, Oct. 1994, p. 20.
- "Sonication Treats Water Mold, Fungi In Wastewater," by Alex Z. Gilgur, Sol E. Lyandres and John P. Sargent, October 1994, p. 22.

**Water Pollution Control**

- "Water Quality 2000 Builds A Consensus," by Lisa K. Neal, January 1994, p. 24.

- "Disinfection Options," by John Calmer, May 1994, p. 38.
- "Surgical Dredging Controls Turbidity," by Eric Seagren, June 1994, p. 56.
- "Is Pump And Treat The Best Solution?" by J. Hilton Frey, Kathleen Shelton and Isidoros Zanikos, July 1994, p. 24.
- "Land Use Habits Impair U.S. Waters," by Lawrence A. Selzer and LaJuana S. Wilcher, August 1994, p. 12.

**Wetlands**

- "Wetlands Debate Still Far From Over," by Benjamin H. Grumbles, January 1994, p. 32.

**Parker Dry-Disconnects Are Preferred For What They Won't Do!**

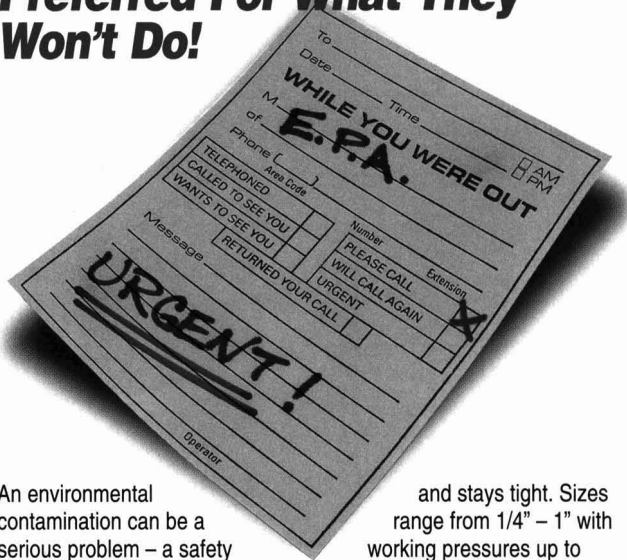

An environmental contamination can be a serious problem – a safety hazard, an expensive clean up, and an embarrassment difficult to explain. With dry-disconnects from **Parker**, you can avoid this problem. By utilizing flush-face valves, Viton™ or Nitrile™ seals, Teflon™ backup washers, steel or stainless steel springs, and Tungsten Carbide or stainless steel locking balls, **Parker** has created the preferred coupling — the dry-disconnect that seals tight

and stays tight. Sizes range from 1/4" – 1" with working pressures up to 3000 psi.

**For more information, call: 1-800-C-PARKER**

**The Leader In Advanced Dry Technology**



Parker Hannifin Corporation  
 Quick Coupling Division  
 8145 Lewis Road  
 Minneapolis, MN 55427  
 PH: 612/544-7781 FAX: 612/544-3418

**Genuine Parker Parts**



**Environmental PROTECTION**

**Article Reprints**

*Environmental Protection* offers reprints in quantities of 100 or more, in black-and-white, 2-color and 4-color. For more information and prices contact:

Environmental Protection Reprint Department  
 3630 IH-35  
 Waco, TX 76706

or call  
 (817) 776-9000  
 Ext. 7018

## Lab Wins USDE's Award For Pollution Prevention

By completely eliminating a potentially major source of hazardous waste, Argonne National Laboratory won the U.S. Department of Energy's first Pollution Prevention Award for Zero Generation. The process, which will save the lab more than \$500,000 per year in disposal costs, was developed to clean metal parts for Argonne's Advanced Photo Sources, a \$467 million materials science research facility now under construction on a 79-acre site at Argonne. The facility is expected to provide the world's brightest beams of X-rays for research.

To prevent contamination, storage ring sections originally were to be dipped in 15-foot-long tanks of sodium hydroxide, a procedure that would have produced 3,000 gallons of hazardous waste per month at a cost of \$600,000 per year. But a group of Argonne scientists and engineers developed a process of dipping the storage ring sections in a bath of alkaline detergent and then subjecting them to high-frequency sound waves. The used detergent solution is non-hazardous and can be handled by the lab's wastewater treatment plant.

## Public Expresses Concern About Corporate Policies

Does the public really care about corporate attitudes toward environmental matters? Yes, according to a national survey by Walker Research, a business unit of the Walker Group.

The public's concern implies bottom line consequences for business as consumers make purchasing decisions, investors decide where to put their money and employees sift through job offers.

According to the survey, 78 percent of all consumers are currently avoiding or refusing to buy from certain businesses because of negative perceptions they have of the companies. Seventy percent said that, even if a discount were offered, they would not buy from a company they regard as not socially responsible. Sixteen percent said they actively seek information about a company's business practices before purchasing. Twenty-six percent of investors said business practices and ethics are extremely important to investment decisions, while employees are more attracted to and retained by companies perceived as being good corporate citizens.

## Enough Capacity For 20 More Years

EPA has released a report showing sufficient national capacity to manage all hazardous waste projects to be generated through 2013.

The Draft National Capacity Assessment Report is based on state capacity assurance plans, which provide assurance of availability of hazardous waste treatment or disposal capacity for hazardous waste expected to be generated within the state for 20 years. States must assure capacity before they can enter into cooperative agreements or contracts with EPA to receive Superfund remedial action funds.

Copies of the report and the executive summary (EPA 530-9346) can be obtained by mailing a request to the RCRA Docket Information Center, Office of Solid Waste (5305), EPA, 401 M St. SW, Washington, D.C. 20460, or by calling the RCRA hotline at (800) 424-9346. The report also is available on the Internet System through the EPA Public Access Server at [gopher.epa.gov](http://gopher.epa.gov).

## Agency Proposes Phaseout Of Post-Closure Permits

EPA has proposed changes to the post-closure care regulations under RCRA for facilities with land disposal units such as landfills and surface impoundments. About 1,000 land disposal facilities in the United States are closed or closing and are required to obtain post-closure permits.

To allow regulatory agencies to use the most effective method available to address these facilities, EPA has proposed to eliminate the permit requirement for post-closure facilities. The agency proposed that EPA or the state select from a variety of legal authorities, including the post-closure permit, to impose post-closure requirements. This would give EPA and states greater flexibility in setting clean-up priorities at RCRA facilities. The agency also proposed to expand states' authorized programs to include corrective action authority for interim status facilities.

## Treatment Guides Adopted For Land Banned Wastes

EPA issued a rule that makes a significant impact on facilities managing hazardous wastes subject to land disposal restrictions. The rule:

- Promulgates treatment standards that

must be achieved before land disposal for newly identified organic toxicity characteristic wastes;

- Promulgates treatment standards that must be achieved before land disposal for all newly listed coke by-product and chlorotoluene production wastes; and
- Mandates that ignitable characteristic wastes with a high total organic carbon content and toxic characteristic pesticide wastes being injected into Class I nonhazardous waste injection wells to either be injected into a well that is subject to a no-migration determination or be treated by the designated land disposal restriction treatment method.

The rule also establishes a set of Universal Treatment Standards; provides clarifying guidance regarding treatability variances; and modifies the hazardous waste recycling regulations that will allow streamlined regulatory decisions to be made regarding the regulation of certain types of recycling activities.

## Attorneys Critique BEN Model Software Program

Washington Legal Foundation attorneys have offered an evaluation of EPA's Ben Model software program that calculates economic benefits derived from noncompliance with environmental laws. Attorneys James Burnley, Phillip Brady, Robert Kirshner and David Zoll have suggested serious flaws in the assumptions of the BEN Model which result in millions of dollars in fines being assessed against American businesses.

EPA's policy is to impose fines on violators that are at least equal to the economic benefit of noncompliance. The model has never been published for notice and comment, the group said. Therefore, the trade associations they represent, along with the National Association of Manufacturers and the U.S. Chamber of Commerce, have filed a petition for rulemaking with EPA, formally requesting that the methodology of the model be subjected to public scrutiny.

To evaluate noncompliance economic benefits in the BEN Model, numerous inputs are required, such as dates of noncompliance, the capital and annual operating costs of equipment, the useful life of equipment and an inflation and discount rate. In question is how EPA determines inputs such as the rate in discounting cash flows and the very high rate used in compounding past economic savings forward to the date of penalty payment.

EP

# PRODUCTS & SERVICES

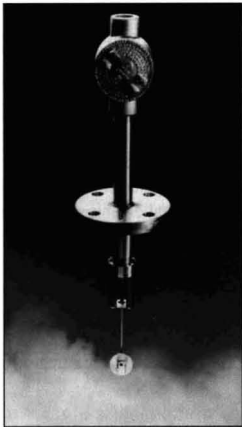

## Strain Gage Flowmeter

The Ramapo Mark V strain gage target flowmeter is built with no moving parts and can be used for liquids and cryogenics, air, gases and saturated and superheated steam. Features include easy installation, in-line maintenance, easy field calibration, bi-directional flow capability and a low pressure drop that provides for economy on pump size.

**Hersey Measurement Co.**

Circle 110 on card.



## Line Locators

Four versions of the 9800 Line Locator Series offer up to three active frequency options. All offer passive 60 hz and RF locating capabilities. The 9800 Transmitter's built-in ohm meter automatically measures line resistance and determines the quality of ground at power up. Patented distance-sensitive left-right guidance and digital signal strength guide to the conductor.

**Metrotech**

Circle 111 on card.

## Ventilation System

On a storage building, this ventilation fan with a motor encapsulated from a building's contaminated exhaust air and cooled by an outside fresh air breather tube. An explosion proof motor, centrifugal wheel and electrical connections are accessible through a removable



end cover. A fire alarm automatically shuts down the fan and HVAC systems.

**CID Associates**

Circle 112 on card.

## Port Ball Valves

The FVL100 series full port ball valves are molded of polypropylene. Glass-reinforced end caps and valve stems provide support. Other features include an O-ring valve-seal stem and stop blocks that pro-



vide on/off positioning. A long handle provides an easy grip and self-lubricating Teflon ensures long life. A tapered transition between the pipe and ball make for low pressure loss.

**Omega**

Circle 113 on card.

## Fume Extraction Systems

This multi-product brochure illustrates the full range of Fume Extraction Systems designed to remove hazardous fumes from the worker's breather zone. The four-page, brochure includes photographs and specifications for various fume extraction tools. The advanced three-stage filtration method used to remove noxious odors and microscopic particles is described.

**Pace Inc.**

Circle 114 on card.

## Storage Lockers

Available in six sizes, the new N-series prefabricated, relocatable steel lockers are designed for single or double tier storage of palletized materials or individual containers. Standard features include continuously welded, heavy-gauge



steel construction, secondary containment sump, removable floor grating, a chemical resistant coating and security-locking system.

**Safety Storage**

Circle 115 on card.

## Oxygen Analyzer

This stable oxygen analyzer with 0.001 percent O<sub>2</sub> resolution for environmental and physiological applications operates on the principle of magnetic susceptibility of oxygen gas. The sensor has a built-in temperature control chamber to eliminate environmental influences. A companion Infrared

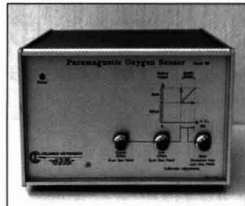

CO<sub>2</sub> Analyzer is offered for analyzing CO<sub>2</sub> and CH<sub>4</sub> gases.

**Columbus Instruments**

Circle 116 on card.

## Tank Emissions Calculator

The Storage Tank Emissions Calculator preserves complete compliance, has editable meteorological and chemical databases, considers up to 50 chemical components per stored material, calculates speciated emissions using Raoult's law, provides detailed and summary reports. Current version includes rapid access to chemical data files, an emission output report suitable for post-processing and improved data consistency checking.

**Waid and Associates**

Circle 117 on card.

## Flow Monitor

The FPM-9010 Series digital flow monitor is designed for liquid flow rate measurement and control in process pipes. This monitor accepts frequency inputs up to 10kHz or 4-20mA or 0-5 Vdc inputs from flowmeters. Analog outputs are automatically linearized after

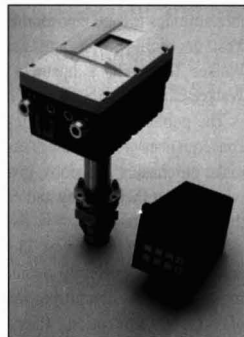

respanning for maximum signal accuracy. The FPM-9010 accepts input from any standard AC voltage source or 16 to 30 V dc source.

**Omega**

Circle 118 on card.

## Carbon Regeneration

This steam generation service is provided by utilizing a

# PRODUCTS & SERVICES

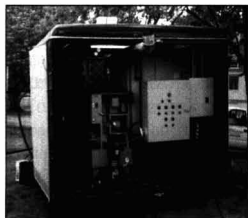

mobile steam regeneration trailer. The trailer is capable of producing 250 pounds of steam per hour at 400 degrees. The regeneration system includes an efficient method for condensing the steam and decanting the associated product.

## SouthStar Systems

Circle 119 on card.



## Nitrogen Analyzer

The DN-1900 analyzer is designed for quick testing of organic nitrogen in wastewater, sea water, drinking water and industrial water. The DN-1900 measures total nitrogen, nitrate/nitrite and organic nitrogen by difference in a range of 0 to 200 ppm N. The instrumental method uses two channels for analysis. The nitric oxide concentration from both channels is determined using a chemiluminescence detector.

## Dohrmann

Circle 120 on card.

## Rotary Concentrator

This deep bed rotary concentrator improves removal effi-



ciency of low-concentration VOCs (500 ppm or less) in industrial exhausts. The system produces a five- to 10-fold increase in organic concentrations, with correspondingly lower air volumes for downstream destruction or recovery operations.

## Barnaby & Sutcliffe

Circle 121 on card.



## Sediment Clarifier

A new iron/sediment clarifier has been added to a line of modular groundwater treatment units. It is designed for removal of precipitated iron and sediments from groundwater before subsurface injection. Particulates are removed in the unit by a combination of gravity settling and filtration on a series of vertical fabric filter plates.

## Carbtrol

Circle 122 on card.



## Liquid Measurement

The Probe is a non-contacting, ultrasonic level measurement device for liquids and is available in versions for hazardous or sanitary applications, ranging up to 16 feet or to 32 feet with the new model. The self-contained unit provides a reversible 4-20 mA output proportional to liquid level or space and can interface with virtually any analog input device.

## Milltronics

Circle 123 on card.

## Water Treatment

This Modular System brochure describes the building block design for meeting water

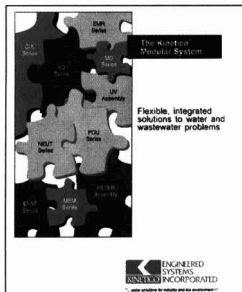

and wastewater treatment needs for printed circuit board, electronics, metal finishing, groundwater remediation and other industries. Several systems can be integrated to form a complete wastewater treatment package.

## Kinetic

Circle 124 on card.

## Disposable Coveralls

These disposable coveralls are available in white or beige in splash-resistant polypro. They come in super comfort 1.25-ounce or heavy duty 1.75-ounce weights and have elastic cuffs and/or hood and

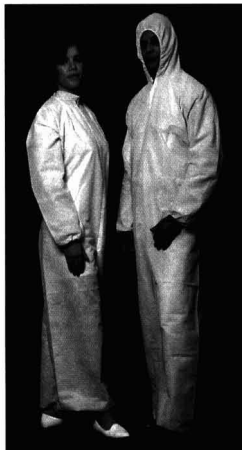

boot options. The garments have a zipper front and are generously sized from large to extra-extra large.

## Inter-Apparel

Circle 125 on card.

## Twin Piston

The Matrx twin piston actuator's Safekey provides a safety lock against inadvertent disassembly and release of the spring and eliminates stress concentration caused by conventional cap screws or helicoils while increasing strength. The Safekey is one of many design improvements that provide extended spring life,



greater operating flexibility and improved safety.

## Xomox

Circle 126 on card.



## Absorbent Laminates

A family of super absorbent laminates can be customized to suit a wide variety of needs. Laminates have been developed with fluid impervious backing to protect tabletops from hazardous spills in hospitals and laboratories. Laminates also are designed for potential spill containment in packaging.

## Gelok

Circle 127 on card.

## Chemical Flowmeter

The 990DFT In-Line Transit-Time Flowmeter is ideally suited for low velocity, small line applications. The non-wetted transducer design, constructed of CPVC or Kynar



tube material, allows the unit to be used on the most aggressive chemical applications. It uses MultiPulse Transit-Time technology, a patented, all digital measurement technique.

**Controlotron**

Circle 128 on card.

**Biocatalytic Treatment**

This biocatalytic system, using Celgene technology, creates favorable byproducts for generators of chemical and pharmaceutical process wastes as well as enhancing the natural



biodegradation of organic compounds. The process generates effluent that satisfies the Clean Water Act standards and the EPA 33/50 waste minimization program.

**Sybron**

Circle 129 on card.

**Isolation Valve**

The newly redesigned Model T13 transmitter isolation valve was made for installation near the base of liquid storage tanks to isolate DP cells. The new valve is available in 316 or 317 stainless steel as well as other alloys and includes a yoke

design that is integrally cast as a part of the body. The overall height is reduced, permitting installation in smaller spaces.

**Wey Valve**

Circle 130 on card.



**Precipitation Gauge**

These precipitation measuring instruments use tipping bucket mechanisms and switches. Designed specifically for monitoring in adverse conditions, these gauges require no regular maintenance and give years of trouble-free operation.

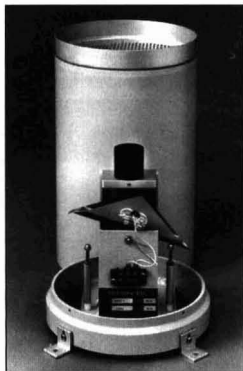

tions. Jeweled bearings reduce wear and friction. Self-emptying stainless steel buckets with Teflon coatings prevent sample retention.

**Met One Instruments**

Circle 131 on card.

**Toxic Gas Sensor**

The Twistik toxic gas sensor/transmitter is designed for single- or multi-gas installations with a high number of



detection locations. It has a quick-release connector that makes it easy to remove for sensor calibration every three months. Twenty-two gas-specific models are available. Twistik has automatic power back-up from an integral lithium battery that maintains sensor bias for up to two weeks.

**EIT**

Circle 132 on card.

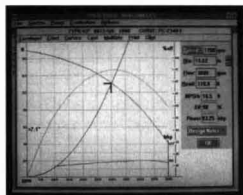

**Pump Software**

A new software program designed to select and evaluate centrifugal pumps for customers' specific pumping requirements is now available on a single computer disk. It presents a range of individual pumps, then evaluates them under varying pumping conditions. The customer receives a detailed pump analysis including the annual power cost.

**Paco Pumps**

Circle 133 on card.

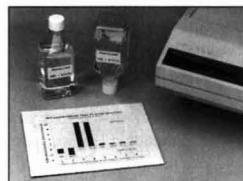

**Bioreactivity Tests**

Two new protocols have

been released that substantially increase the effective sensitivity of the Microtox and CIDE-TRAK tests while retaining speed and precision. The Comparison Screen protocol is designed for high throughput of large numbers of low bioreactivity samples, while the Comparison Test protocol provides higher precision.

**Microbics**

Circle 134 on card.

**Ionization Detector**

This new flame ionization detector, the EI Model 680, is portable, integrated and safe, rated explosion proof Class 1,



Division 1, Group A-D. The microprocessor-based FID has advanced technology designed on EPA Method 21 Compliance testing for fugitive emissions monitoring, industrial hygiene monitoring, soil/water contamination detection and underground storage tank leaks.

**Environmental Instruments**

Circle 135 on card.

**Three-Drum Storage**

The Triple King is a 100 percent polyethylene three-drum secondary containment unit designed for areas where space for palletized loads is not available.



The side-by-side design creates an easy access dispensing area that contains drips and



# PRODUCTS & SERVICES

leaks without changing an already existing drum arrangement. The unit is completely recyclable.

## Safe Environmental Storage Corp.

Circle 136 on card.

## Gas Monitor

The Model 2001 is a compact, solid-state, fixed-installation combustible gas

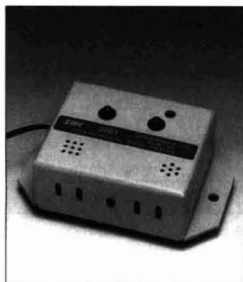

monitor designed for continuous area monitoring. This

low-cost monitor features audible and visual alarms, plus an optional dry contact relay. When the combustible gas in the area reaches the pre-set alarm limit, the monitor activates a sustained alarm.

## Sierra Monitor

Circle 137 on card.

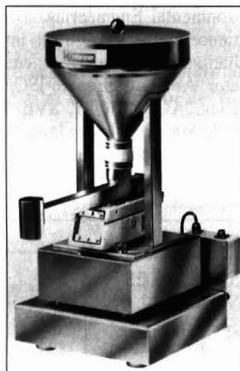

## Compact Feeder

This KV-1 compact vibratory loss-in-weight feeder provides precise gravimetric flow control of free flowing, granular, abrasive or friable materials in applications involving lower rates or limited space. Designed to deliver rates from .25 to more than 500 lb/hr, the feeder has no mechanical parts subject to wear, is easy to clean and is virtually free of maintenance.

## K-Tron Soder

Circle 138 on card.

## Testing Services

This company provides a full-service environmental laboratory with analytical, research and consulting services. The lab offers comprehensive testing in soil, water, wastewater, solid



PEOPLE ARE THE CHEMISTRY AT LANCASTER LABORATORIES.

waste, hazardous waste and air quality. Experienced in EPA CLP, the firm holds major accreditations and certifications. For clients with tight schedules, the company provides ExpressLAB service with results in one to five days.

## Lancaster Laboratories

Circle 139 on card.

continued from page 36

decisions made on false assumptions.

The use of fuzzy logic as the decision making process leads to more opportunity to attack a siting decision as arbitrary and capricious. Rather than a single best professional judgment made by a siting decision maker, fuzzy logic processes give rise to hundreds of professional judgments based upon specific pieces of data. If a mistake in a piece of data is made that would change the fuzzy logic outcome, the siting decision must be overturned. If one of the professional judgments made during the process is clearly arbitrary, then the decision is subject to challenge.

The three siting models have significant similarities and differences. Each can benefit from a clear delineation of factors and values to be considered. Each can benefit from the application of fuzzy logic decision tools and from full and frank discussions of the detriments and benefits and strong public participation.

Governmental, especially legislative, processes are best able to gauge public sentiment and obtain both public input and support.

The private system tends to be the least expensive system because of its flexibility and its tendency to minimize the transactions costs associated with higher degrees of public and governmental involvement. The private process may not be effective, particularly when siting controversial facilities, because of its limitations in obtaining public input and confidence.<sup>21</sup>

Siting large controversial treatment, storage and disposal facilities can benefit from the use of a quasi-governmental siting process. This hybrid process can obtain public input and public confidence more readily than the private system and analyze technical data with greater facility than most governmental processes. The quasi-governmental system is more costly and time consuming than private siting processes. This inefficiency militates

against use of the quasi-governmental process for larger and more controversial decisions.

## References

1. Friedman, M. & R., *Free To Choose*, (1980) at 9-18 and 222-227.
2. Edwards, Neill, "Yucca Mountain Or: How We Learn To Stop Worrying And Love The Department Of Energy's High-Level Waste Disposal Guidelines," 12 *Virginia Environmental Law Journal* 271 (1993).
3. *Solid Waste Disposal In North Carolina* (NC Department of Environment, Health and Natural Resources) 1993.
4. Williams, D. "Environmental and Democratic Legitimacy," IV *Duke Environmental Law and Policy Forum* 1, 6-9 (1994); R. Coase "The Problem of Social Cost" 3 *J.L. Econ.* 12 (1960); W. Baxter, *People or Penguins: The Case For Optimal Pollution* 8 (1974).
5. Hornstein, D. "Reclaiming Environmental Law: A Normative Critique Of Comparative Risk Analysis," 1991 *Columbia L. Rev.* 562, 587-92 (1992).
6. 42 U.S.C. Sec. 6901 et. seq. Also 42 U.S.C. Sec. 6921(b).
7. A hazardous waste incinerator sited in Woodlands, N.C. was canceled after activists obtained the repeal of the North Carolina Hazardous Waste Management Act of 1989.
8. Juang, C.H.; B. Clistler and K. Lee. "A New Approach for Siting Landfills," 18 *National Association of Environmental Professionals Annual Conference Proceedings* 796 (1993).
9. *Id.* at 797.
10. *Id.* at 804.
11. Juang, C.H.; X.H. Huang and S.D. Schiff. "Determination of Weights for Criteria for Decision Making by the Fuzzy Eigen Vector Method," 9 *Journal of Civil Engineering Systems* No. 1, pp. 1-16.

Mark A. Finkelstein is a partner in the Raleigh, N.C., law firm of Finkelstein & Diab. He served on the North Carolina Low Level Radioactive Waste Management Authority, which sited a low-level waste repository for the Southeast Compact.

# EMPLOYMENT

## CLASSIFIED ADVERTISING

Ad copy is due 30 days prior to issue date.

### 1995 RATES:

Line ad: \$25.00 per line for Boldface & titles. Additional lines: \$15.00. Minimum: 7 lines @ 45 characters per line maximum.

### Boxed Display:

\$145/column inch.

Column width is 2 1/8"

Camera-ready art preferred.

Design and typesetting services available for a nominal charge.

Blind Box #: \$15.

Send ad copy to:

## ENVIRONMENTAL PROTECTION

P.O. Box 2573

Waco, TX 76702-2573

Linda Flores  
North Eastern Region

Bert King  
Southeastern, Central  
and Western Regions

For assistance call:

(817) 776-9000

FAX (817) 776-9018

Environmental Protection reserves the right to decline, accept, or withdraw advertisements at its discretion. The publisher reserves the right to edit copy.

**Environmental Engineer - Charlotte, NC** - Conduct hazardous/non-hazardous field investigations requiring soil & groundwater assessment, sampling, monitor well & recovery well installation, soil boring installation, field testing, hydrogeological analysis & data reduction. Preliminary environmental site assessment related to subsurface contamination & appropriate report generation. Provide aquifer remediation system design using state-of-the-art treatment technologies, oversee system performance & site remediation. Monitor well surveying, site mapping, groundwater modeling, analysis of groundwater flow pattern & prepare contour maps. Report writing including initial site characterization, comprehensive site assessment, tank closure report & corrective action plan. Req's: M.S. Environmental or Civil Engineering + 1 year experience in job offered or as Environmental Field Engineer or Civil Engineer or combination thereof. Civil Engineering degree must be with concentration in Environmental Engineering. M.S. degree can be substituted with B.S. + 2 years experience. Experience must involve soil/groundwater sampling, monitoring well installation, site surveying, operation of organic vapor analyzer & photo ionization detector. Ability to prepare ISC, CSA & CAP reports. Knowledge of groundwater modeling, AQTE SOLV, SVE, Hydrostat, Surfer & Grapher & familiarity with applicable State regulatory laws. \$28,560/yr. 8-5, 40 hrs/wk. Apply to nearest Job Service office or submit resume to: Job Service, 500 W. Trade St., Charlotte, NC 28202. All resumes *must* include social security # and Job Order # NC 2643863 and DOT code 029.081-010.

### Smith & Associates RECRUITING for

- Environmental • Safety
- Civil • Hydrogeologists

P.O. Box 829 Brandon, FL 33509  
(813) 869-2611

### Environmental Laboratory Salesperson Wanted

Environmental testing laboratory looking for confident, self-motivated, mature individuals to sell laboratory services nationwide at very competitive rates and the fastest turn-around time in the country.

Call (602) 881-4500

### CORPORATE ENVIRONMENTAL MNGRS. & CONSULTANTS NATIONWIDE OPPORTUNITIES 40 - 150 K

Mfg • Chemical • Envir • I & H • Safety • Civil  
Ansara, Blekford & Flske  
P.O. Box 239, West Spfld., MA 01090  
Peter Ansara (413) 733-0791 • Fax (413) 731-1486  
SAME DAY RESPONSE



Over 20 years in E H & S recruiting  
Industrial Opportunities Nationwide  
Box 1325, Palm Harbor, FL 34682  
Randy Williams • 813-787-3225 • FAX 813-446-0546

### SUNBELT OPPORTUNITIES \$28,000 to \$78,000

Immediate openings nationwide in virtually all Environmental/Safety & Health related disciplines.  
Contact: Greg Whit, C.P.C.,  
PROFESSIONAL PERSONNEL ASSOCIATES, INC.  
7520 E. Independence Blvd., #160 - Charlotte, N.C. 28227  
(704) 532-2599 (704) 536-8192 Fax

### Inside Sales/Customer Support

Leading manufacturer of groundwater/soil remediation equipment seeking an inside sales person for corporate office in Gainesville, FL to handle sales inquiries and provide customer support. Experience in the environmental industry a must. Qualified candidates must be energetic, self-motivated sales/customer oriented with 3-5 years sales experience. Send resume with salary expectations to GeoPure, Attn: Sales Manager, 2300 NW 71st Place, Gainesville, FL 32653-1699. EOE

### MANAGER ENVIRONMENTAL PROTECTION DEPT. ORANGE COUNTY GOVERNMENT

We are currently seeking qualified applicants for this position directing the activities of the dept. engaged in protecting the community from all forms of air, water and ground pollution.

We require a Bachelor's degree in Environmental or Sanitary Engineering or a related field and a Master's degree in a related scientific field and five years of experience in environmental or sanitary engineering. Requires Florida registration as Professional Engineer.

Salary range \$51,812 to \$78,956, to include an excellent benefits package. Veteran's Preference does not apply to this position. Qualified applicants should forward a resume by January 27, 1995 at 2:00 PM to:

Orange County Government  
Human Resource Department  
201 S. Rosalind Avenue  
Orlando, FL 32801  
Position Number 94-2352

EEO/M/F/H

**FAX US YOUR AD  
817-751-5171**

# EMPLOYMENT

**Environmental and Safety Designs, Inc. (EnSafe)** is a rapidly growing consulting and industrial hygiene firm specializing in environmental services. We are seeking dedicated professionals to fill the following positions:

**Environmental Engineer, Memphis, TN:** BS/MS Chemical, Civil or Environmental Engineers with experience in the development of remedial actions for contaminated soils and groundwater. Minimum of 2-5 years experience required. EIT/PE preferred.

**Environmental Chemist, Memphis, TN; Nashville, TN; Dallas, TX; Charleston, SC:** BS in Chemistry with 1-5 years environmental laboratory or consulting experience. Familiarity with environmental laboratory methods, QA/QC and data validation a plus.

**Engineer, Raleigh, NC:** BS/MS Civil, Chemical or Environmental Engineering. Minimum of 3-5 years experience in remediation or site investigations. North Carolina Professional Engineer (P.E.) certification essential.

**CAD Operator, Nashville, TN:** Minimum of 5 years experience preparing technical drawings using AutoCad, familiarity with AutoCad Rel. 12, digitizing large maps and cut/fill quantities, experience with Drawing/CAD Production Management.

**Contingency Planner/Trainer, Memphis, TN:** BS/MS Chemistry, Biology, Environmental Science or related discipline. Requires ability to develop and present complex environmental response issues such as contingency plans, OPA '90 drills and exercises. Natural ability as a trainer is essential.

**Engineer, Norfolk, VA:** BS/MS Civil, Chemical or Environmental Engineering. Minimum of 3-5 years experience in remediation or site investigations. Virginia Professional Engineer (P.E.) certification essential.

**Compliance Specialist, Pensacola, FL:** Engineer or scientist with minimum 2 years industrial, environmental compliance experience. Minimum BS in environmental science/engineering, physical science, or related curriculum.

**Environmental Engineer, Memphis, TN:** BS/MS Civil or Environmental Engineering. Minimum 0-1 year experience. EIT preferred.

**Geophysicist, Memphis, TN:** BS in Geosciences with emphasis in geophysical exploration; geophysics degree preferred. Minimum 1-2 years environmental experience and practical field application experience (geophysics) particularly near-surface high-resolution techniques.

**Geologist, Dallas, TX:** BA/BS degree in Geology, Geophysics, or Geologic Engineering. Minimum 1-2 years experience as a geologist in environmental field required. This is a temporary position expected to last for approximately 3 years.

**Geologist, Nashville, TN:** BA/BS degree in Geology, Geophysics, or Geologic Engineering. Minimum 1-2 years experience as a geologist in environmental field required.

EnSafe has an excellent benefits plan including paid insurance, 401k and profit sharing. If you are interested in joining our team, please submit your resume along with salary history to:



Attn: LRH  
P.O. Box 341315  
Memphis, TN 38184

EnSafe is an Equal Opportunity/Affirmative Action Employer.

# EMPLOYMENT

## ENVIRONMENTAL & SAFETY ENGINEERS FACULTY CONSULTANTS

(Part-time at home)

Recognized independent study university is seeking adjunct faculty to assist mid-career professionals with independent study courses. All consulting can be done via telephone and does not conflict with your primary employment schedule. Requires Master's or Doctorate degree. Please submit resume to:

Paul Saltman  
Kennedy-Western  
University  
501 Marin St.  
Thousand Oaks, CA 91360

## Environmental professionals are no longer as hard to find as a needle in a haystack...



thanks to a new service called **The National Environmental Resource Center** (NERC) which is establishing a central database of qualified environmental professionals that can be accessed by companies looking to hire additional staff. If you're working in any facet of the environmental industry, you should register with the NERC so that companies, institutions, and agencies will know your educational background, professional skills, work experience, registrations, certifications, or licenses held, and personal requirements.

Registrants can choose whether or not to have information released to companies seeking to fill job openings. Companies seeking professionals with your background could present job opportunities to you even though they do not know your name, address, or company presently working for. Registrants actively looking for a new position would have their information immediately released to hiring officials seeking their background. Registrants would receive a newsletter once a quarter filled with valuable information about industry hiring practices. If you are not registered with the NERC, finding you will be as hard as finding that needle in the haystack.



"People, your most valuable resource"

For more information call Billy Logue  
**1-800-506-HELP**

5900 Mosteller • Suite 1500 • Oklahoma City, OK 73112



### Opportunities For All Environmental Professionals

- Profit Center Management
  - Senior Technical Positions
  - Project Management
  - Consulting and Industry
- Air Quality • Water/Wastewater • Solid Waste • Hazardous Waste  
Groundwater • Remediation • Treatment Systems Design

#### REPRESENTATIVE CLIENTS:

Dames & Moore • OIRM • Foster Wheeler • ICF Kaiser • ESE • Bechtel  
Bristol Meyers • Metcalf & Eddy • Brown & Root • ASI • Amoco •  
Exxon Chemical • EG&G • Brown & Caldwell • HDR • Merck • Harding  
Lawson • EMCON • Rust • Kodak • Shering-Plough • CDM • Archer  
Daniels • Hoechst Celanese • ATEC

#### Coast to Coast Contacts and Network Second to None!!

Brian MacLennan, President / Angela Swope, Assistant  
1124 Longmeadow Lane Monroe, NC 28110  
■ Phone: 704-282-1372 ■ Fax: 704-282-1374

#### CAREER OPPORTUNITIES

### National Environmental Placement

COMPLIANCE PERMITTING HEALTH SAFETY  
REMEDIATION CLEANUP HAZARDS RISK

Fees Paid by Client Firms

Caseley & Associates, Inc.  
P. O. Box 1899, Richland, WA 99352  
(509) 943-0501 or FAX (509) 946-7084



#### ENVIRONMENTAL/SAFETY

**\$25,000 - \$110,000**

NATIONWIDE SPECIALISTS - ALL DISCIPLINES  
Environmental Engineers, Chemists, Safety & Health -  
Manufacturing, Chemical, Corporate & Consulting Firms.  
**ELIAS ASSOCIATES INC.**

P.O. Box 396 Dept EP • East Brunswick, NJ 08816  
Gary Elias 908-390-4600 • FAX 908-390-9769

Fax your ad today  
call, (817) 751-5171.

Classified ads serve as good reference tools for your potential clients.

# EMPLOYMENT/CLASSIFIEDS

## FOR SALE

### FOR SALE/LEASE

6000 Sq. Ft. Building  
4.6 Acres of Land

Zoned: Mixed Haz & Radioactive  
waste processing facility.

Public Hearing NOT required

Local support

Easy Access to I-76, NE Colorado



**303-480-1180**

### EQUIPMENT FOR SALE

Scitex XRF Spectrum Analyzers

Used in Good Condition

Call NTL (718) 784-2626

FOR SALE: HEAVY METALS & HYDROCARBON/WATER FILTRATION SYSTEM. REMOVES HEAVY METALS, HYDROCARBONS (OIL, GAS) & SEDIMENT. DISCHARGE IS BELOW STATE & FEDERAL EPA GUIDELINES. PRICED LESS THAN OTHER SYSTEMS. CALL IMMEDIATELY (800) 424-3698, STRATEGIC SYSTEMS OF AMERICA.

## SOFTWARE

**LOGICAL**  
TECHNOLOGY, INC.

**Environmental, Health  
& Safety Software**

Hazardous materials management

Compliance reporting

Materials & waste tracking

**Comprehensive list-of-lists  
MSDS Services**

The Logical Choice for Compliance

1-800/COMPLY 1

### MIRS: the Integrated Compliance Software Choice

Environmental & Safety modules for:

- EPA-approved Form R
- OSHA Hazcom
- Air, Water, Waste
- SARA
- MSDS
- Permit
- Inventory



A V Systems, Inc.  
(313) 973-3000

## CONTINUING EDUCATION

### OSHA TRAINING

Providing Quality Environmental Safety Training

- ASBESTOS CONTRACTOR/  
SUPERVISOR/WORKER
- CONFINED & ENCLOSED SPACES &  
OTHER DANGEROUS ATMOSPHERES IN  
SHIPYARDS 29 CFR 1915
- HAZWOPER 29 CFR 1910.120
- CONFINED SPACE 29 CFR 1910.146
- DOT HAZARDOUS MATERIALS  
HANDLING CERTIFICATION  
HM -181 & HM-126F
- LOCK-OUT TAG-OUT
- RESPIRATORY PROTECTION
- HAZARD COMMUNICATION
- BLOODBORNE PATHOGEN
- LEAD CONTRACTOR, WORKER &  
REFRESHER

Complies with regulatory requirements mandated by OSHA, DOT, EPA, NIOSH, NESHAPS, AHERA, SARA, CERCLA.

Courses are conducted at your location or ours, and are adapted to a variety of schedules. For more information; Call Today!

ATARUS TRAINING INSTITUTE, INC.  
196 BUSINESS PARK DRIVE,  
VIRGINIA BEACH, VA 23462  
804/499-9900, Ext. 41 Fax 804/499-9933

**EXPAND YOUR BUSINESS  
HORIZONS WITH CONTINUING  
EDUCATION COURSES.**

## EQUIPMENT RENTAL

**CAE**

**CAE Instrument Rental**

A Division of Clean Air Engineering

**Quality, Service  
It's that Simple.**



- OVA s
- LEL s
- HNU s
- PUF s
- Sniffers

800-553-5511

**Fax Us Your Ad  
817-751-5171**



**Occupational and Environmental  
Safety Training Division**

Texas Engineering Extension Service  
The Texas A&M University System

### HANDS-ON TRAINING

- Site Assessment/Sampling/Remediation
- Underground Storage Tank Systems
- Hazardous Waste Management
- Lead/Asbestos Abatement
- Emergency Response
- Confined Space Safety
- OSHA Compliance
- Oil Spill Control
- HAZWOPER
- Wetlands

**TEEX**

Customized, site-specific training available  
1-800-252-2420

## BID OPPORTUNITIES

**ENVIRONMENTAL  
BID OPPORTUNITIES**

**WE KNOW WHERE  
THE WORK IS**

6 Regions - Local and  
Nationwide - Federal,  
State, Municipal and Private

SEE WHO HAS THE WORK,  
WHO IS DOING IT,  
AT WHAT PRICES, IN

THE GREEN BOOK REPORT

CALL FOR A COMPLIMENTARY  
EVALUATION COPY

800-527-2204

# CLASSIFIED/PROFESSIONAL DIRECTORY

## CONFERENCES



### New England Environmental Expo

May 9, 10 & 11 1995

WORLD TRADE CENTER, BOSTON

*Largest and Most Comprehensive Environmental Conference and Exposition in the Northeast*

#### Featuring:

- 300 Exhibiting Companies
- Over 80 Technical Sessions on Environmental Management
- Recycling / Solid Waste Congress
- Health & Safety Congress
- Computer Congress for the Environmental Professional

**For More Information Call:**  
**(617) 489-2302**



**1-800-914-4944**

#### QUICKEST TURN-AROUND IN THE U.S.

Quality analysis and customer service are the priorities at IAT Labs. We provide organic and inorganic analysis on-site or off. Call for a brochure or to schedule sampling.

TEST METHOD	COST	TURN-AROUND
1. 8020/8015 (BTEX & TPH)	75.00	2 Days
2. 418.1 (Soil)	28.00	2 Days
3. TCLP (Metals) (Organics)	90.00	3 Days
4. Total Metals (A.A. flame only)	450.00	5 Days
5. Total Metals	7.50	2 Days
6. pH	9.00	2 Days
	4.00	2 Days

**24 HOURS (800) 914-4944**

**Asset Control Services**  
904-886-8321

**Has for Sale:**  
(4) Chem Master Solvent Recovery Systems  
(2) 7.5CM @ \$4,000. each (Like New)  
(2) 55CM @ \$11,000. each (Like New)

## VOC's

- TGNMO by USEPA Methods 25 + 25-C or by SCAQMD Methods 25.1 + 25.2
- CO by USEPA Method 10-B
- CH<sub>4</sub> by USEPA Method 18 for subtraction from USEPA Method 25-A
- Equipment Rental



Triangle Environmental Services, Inc.  
P.O. box 13294  
Research Triangle Park, NC 27709  
(919) 361-2890  
Fax (919) 361-3474

**1-800-367-4VOC's**

## TURNER ENVIRONMENTAL LOGIC, INC.

- Air Permits & Compliance
- Studies & Design
- Emission Control Systems

3439 SW 11th Street  
Deerfield Beach, FL 33442  
(800) 933-8385 • (305) 422-9787  
Fax (407) 422-9723

## The Oxygen Source of the 90s...

For All Environmental Processes



- Standard & Custom Designed PSA Oxygen Systems from 4-60,000 SCFH/r (11-1,577.4 Nm<sup>3</sup>/hr)
- Economical: Generates oxygen on site at less than 1/2 the cost of purchased oxygen
- Exceptional Quality: Highly engineered, safe, reliable, and practically maintenance-free
- Fully Automatic: Microprocessor-controlled for unattended operation



AirSep Corporation  
290 Creekside Drive  
Buffalo, NY 14228-2070 U.S.A.  
Tel: 716-691-0202  
24-Hour Fax: 716-691-0707

**TOLL-FREE U.S./CANADA: 800-874-0202**



June 14 & 15, 1995  
Orange County Convention Center  
Orlando

*Florida's Premier Environmental Show*

*Focused on the Business of Protecting Florida's Environment*

**1-800-881-6822**

## PRODUCTS & SERVICES

**Environmental Leasing Incorporated**  
1-800-252-7448

P.O. Box 580  
132 Corporate Blvd.  
Indian Trail NC 28079  
(704) 821-8777

**JOHN FRASER**  
LEASING MANAGER

Leasing of ISCO Wastewater Samplers, Flow Meters, Flow Monitoring Systems



**Electric - Nuclear - Induction - Acoustic - Video**

- Digital Well Logging Services
- Interpretation - Consulting
- Rental Equipment
- Training & Seminars

**GROUNDWATER ENVIRONMENTAL GEOTECHNICAL**

Principal Office: 17301 W. Colfax, Suite 265, Golden, CO 80401  
(303)279-0171 FAX:279-2730  
West Coast Office: 1160 Industrial Ave. Unit G, Petaluma, CA 94954  
(707)769-9094 FAX:769-1989

Call now to reserve your ad space for the upcoming issue of Environmental Protection.

# PROFESSIONAL DIRECTORY

**SAVE!!**  
**SAVE!!**  
Up to 50%  
and  
More!

522 Meter  
Console

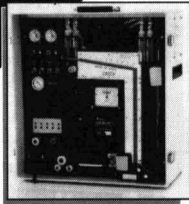

**APEX**  
**INSTRUMENTS**  
SOURCE SAMPLING EQUIPMENT  
Tel: 800 882 3214

## Biosolids Management

- Land Application
- BIO+FIX Alkaline Stabilization
- IPS Composting
- Drying and Pelletizing

**Wheelabrator Clean Water Systems Inc.**

180 Admiral Cochrane Drive, Suite 305  
Annapolis, Maryland 21401 • (410) 224-0022  
A WHEELABRATOR TECHNOLOGIES COMPANY **BIOGRO Division**

HIGH QUALITY FLEXIBLE  
GEOMEMBRANE LINERS  
PVC, PVC-OR, CPE, OGR & DYNAPRENE™  
UNSUPPORTED & SCRIM REINFORCED  
(800) 344-6080 or (908) 302-4257 FAX (908) 302-4220  
200 Cottontail Lane, Somerset, NJ 08873

**HPG**  
International, Inc.



SERVING YOUR CORROSION  
RESISTANT PIPING NEEDS

## Bondstrand® II

Secondary containment systems

Bondstrand II fiberglass secondary containment piping systems combine the corrosion resistance of epoxy and vinyl ester thermosetting resins with the strength of fiberglass reinforcement. The result? Detection and pressure performance that trench liners and ordinary thermoplastic pipe can't match.

**Ameron.**

P.O. Box 801148EP • Houston, TX 77280  
Tel: (800) 370-4FRP • Fax: (713) 690-2842

## GC Sales & Rentals

GC is all we do! Buy or rent from the EXPERTS...TPH, BTEX, VOC, PCB...  
Starting at only \$23 per day  
**SRI Instruments (310) 214-5092**

EARN  
YOUR  
COLLEGE  
DEGREE  
AT  
HOME



- B.S. & M.B.A. in Business
  - B.S. in Environmental Studies
  - M.S. in Environmental Management
  - Approved for tuition reimbursement by major companies.
- For a free catalogue call 1-800-767-CHAD.

**CHADWICK**  
UNIVERSITY

ACCREDITED MEMBER  
World Association of Universities & Colleges

## EQUIPMENT FOR SALE

### Unused Peroxidation Systems

Model CW-360, Ultraviolet  
H2O2 System, T316SS, 200 GPM,  
360 KW, (3) Available...E55083  
**Plate & Frame Filters...E55055**  
7100 Sq. Ft., Mfg. by Edwards &  
Jones, (120) Rubber Recessed  
Plates, 100 psi, (4) Available

Louisiana Chemical Equipment Co.  
P.O. Box 1490 LaPorte, TX 77571  
Phone: (713) 471-4900 Fax: (713) 470-2968



**MUNOX®**  
HUNGRY BACTERIA

For The Biotechnic Elimination  
of Grease, Oil and Stubborn  
Organics in Your

**OSPREY**  
Biotechnics

- Wastewater
- Grease Traps
- Drain Lines
- Lift Stations

1-800-553-7785

2530 B Trainmate Drive Post Office Box 758  
Sarasota, FL 34243 Oneco, FL 34264  
Phone (813) 755-7770 Fax (813) 755-0626

## ATMOSPHERIC CONSULTING SERVICES

AIR POLLUTION MODELING  
for  
Permits Risk Assessment Siting  
METEOROLOGY  
Historical Real Time Forecast  
SPECIAL STUDIES and FORENSICS  
Meteorology Climatology Hydrology  
Ph.D. And Certified Consulting Meteorologist On Staff

STRIP CHART DIGITIZING  
DATA ANALYZING DATA PROCESSING

CUSTOM FORMAT ON TAPE/FLOPPY AND HARD COPY

STRIP CHART FILL-IN OF LOST LOGGER DATA

QUALITY ASSURANCE COMPARISON CHECKS

TIME AVERAGING OR DISCREET POINTS

DATA BASE MANAGEMENT

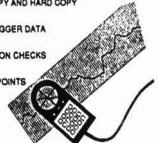

**AIR SCIENCE CONSULTANTS, INC.**

347 Prestley Rd. Bridgeville, PA 15017 (800) 759-9282

Water, Waste Water Environmental Studies/  
Geochemistry Metallurgical Testing  
Qualitative/Quantitative Analysis  
Rapid and Reliable Service 25 Years Experience

**GTECH Laboratories, Inc.**

2640 S. 218 W. Goddard, KS 67052  
Phone: 316-794-8244; FAX 316-794-8064

**EXPAND YOUR BUSINESS**  
HORIZONS WITH CONTINUING  
EDUCATION COURSES.

## MATERIAL SAFETY DATA SHEET PREPARATION SERVICES

Are you looking for a resource to prepare your Material Safety Data Sheets? We can help! Chemical Safety Associates, Inc. has been preparing Material Safety Data Sheets since 1984. CSA can review your current MSDS for accuracy and compliance with Federal and State Specific requirements, or prepare your MSDS from scratch.

- ♦ Fast Accurate Service
- ♦ MSDS Prepared to New ANSI Standard
- ♦ MSDS Prepared to Comply with Canadian Whmis Regulations
- ♦ MSDS Prepared in English, Spanish, French and Other Languages

Call or write us today for details on how we can assist you!

**CHEMICAL SAFETY  
ASSOCIATES, INC.**

9163 Chesapeake Drive  
San Diego, CA 92123-1002

**619/565-0302**

Environmental Protection magazine reaches  
over 90,000 professionals in this market.

# PROFESSIONAL DIRECTORY

## Contaminated Water Problems? Save up to 40%

If you or your client deal with:

- BETX; Tetrachlorethylene; other chlorinated organic water
- Tank bottom water (sludge)
- Hazardous & non-hazardous water hauling
- Ship bilge or ballast water
- Pipe-line condensation
- Contaminated ground water

Enhance your performance of Carbon & Air Stripping systems. Modular equipment package (portable) clean water to 1 ppb.

### New State Of The Art Technology

**OZ Environmental/Aquatic Remediation Technologies, Inc.**  
2080 Industrial Park Road  
Mulberry, FL 33860  
PH: 813-425-0099 Fax: 813-425-9557

Asbestos Analysis - PLM/PCM  
\$7.00 per sample  
AIHA PAT-PCM Proficient, AIHA/RTI-PLM  
Air Quality - Radon-Noise Dosimetry  
Third-Party Air Monitoring



1030 Acorn Trail Dr.  
Florissant, MO 63031  
Tel/Fax (314) 838-5052

**PRECISION ANALYSIS, INC.**

## PIT HOG PUMPS WASTE



LWT Manufactures and leases manned or remote controlled lagoon dredges and pumps. Pumping systems move sludge, sand, silt, residuals and debris from lagoons, tanks, vessels and digesters.

Contract dredging also available.



**LWT LIQUID WASTE TECHNOLOGY**

Box 250, 422 Main St, Somerset, WI 54025  
Call Toll Free 1-800-243-1406

SPECIALISTS IN:

## INDOOR AIR QUALITY

- Testing for Building Related Disease
- Inspection and Testing of HVAC Systems
- Employee Complaints
- Testing for Chemicals, Molds, Bacteria, Asbestos
- Rapid Response-Nationwide



**ATLANTIC ENVIRONMENTAL INC.**  
2 E BLACKWELL ST. DOVER, NJ 07801  
201-366-4660  
REGIONAL OFFICES: ATLANTA • CHICAGO  
1-800-344-4414

## The One-Stop Source for Respirator Cleaning

Georgia Steel & Chemical Co., Inc.  
10810 Guilford Road  
Annapolis Junction, MD 20701  
1-800-296-0351  
Fax (24 hrs.) 301-470-6313

## PUMP REPAIR

AIR SAMPLING PUMPS REPAIRED  
HI VOL, LO VOL, PERSONAL PUMPS  
BATTERY PACKS REBUILT

Warranty Given - Fast Turnaround  
Also: Acetone Vaporizer Sold

**ATLANTA LAB SYSTEMS**  
115 Cedar Trace - Roswell, GA 30075  
404-993-7850

## MICROSEEPS

Vapor Extraction Sampling & Analysis Services

### VESA

- Tired of costly sample bags that are fragile, hard to ship & have limited holding times?
- Join the crowd & switch to *Microseeps Vesa* system.
  - Free sample containers
  - Extended holding times
  - Convenient shipping

For your free VESA demo kit, call or fax your request to *Clark Sharlock* at:

**MICROSEEPS**  
220 William Pitt Way (412) 826-5245 PH  
Pittsburgh, PA 15238 (412) 826-3433 FX

## RENTAL • LEASE

# SPRAY FIELDS



Rain for Rent has fast solutions to your liquid storage and handling needs. Like effluent spray fields. Or hazardous liquid pumps and storage tanks. We design and install systems that suit your requirements. And our rental programs mean you only pay for what you need, for as long as you need it. Call Rain For Rent today, you'll be glad you did.



**National Toll Free (800) 742-7246**

## HAZEN AND SAWYER

Environmental Engineers & Scientists

- Water
- Wastewater
- Solid Waste
- Environmental Studies

Hazen and Sawyer, P.C.  
730 Broadway  
New York, NY 10003  
212 777-8400

Other U.S. Offices

*A terrible thing happens when you don't advertise . . . NOTHING!*



# PROFESSIONAL DIRECTORY

## AIR POLLUTION CONTROL SYSTEMS

**CYCLONE COLLECTORS**  
**SCRUBBERS**  
 CENTRIFUGAL • DYNAMIC  
 MULTI-VENTURI • CONVENTIONAL  
**GAS ABSORBERS**  
 for  
 $SO_2$  •  $Cl_2$  • HF • HCL •  $H_2S$   
 ROTARY GATES • TRICKLE VALVES • DUMP GATES



**CLEAN GAS SYSTEMS, INC.**  
 160-2 REMINGTON BOULEVARD  
 RONKONKOMA, NY 11779  
 TEL: 516-467-1600 / FAX: 516-467-1688

FOR A CLEANER TOMORROW...TODAY

## TRAINING



A Services & Technology Company

- **HAZWOPER Training:** in full compliance with 29 CFR 1910.120
  - **Other training developed to meet clients' needs**
- Corporate rates available.  
 Our facility or yours.

**1-800-338-4487**

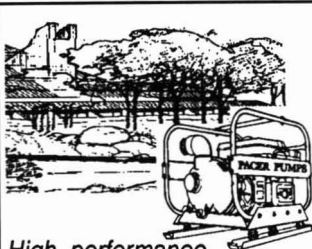

High performance  
 corrosion resistant  
 portable pumps

## PACER PUMPS

One Lark Avenue 717 656-2161  
 Leola, PA 17540-9512 Fax 717 656-0477

**Toll-free 800 233-3861**

*Classified Ads Get Results!*

## LEGGETTE, BRASHEARS & GRAHAM, INC.

Professional Ground Water and Environmental Services

Water Supply • Contamination • Modeling  
 Dewatering Permitting

Wilton, CT  
 (203) 762-1207



Offices Nationwide  
 EST. 1944

## HRC

**HUBBELL, ROTH & CLARK, INC.**

ENVIRONMENTAL ENGINEERING

P.O. Box 824 • Bloomfield Hills, MI 48303-0824 • (810) 338-9241

## CONSULTING & ENGINEERING SERVICE

Call **SHRED-TECH** for  
 Production and Recycling Solutions

**1-800-465-3214**

Manufacturers of Waste  
 Reduction Equipment  
 and Recycling Systems

## DISPOSAL/RECYCLING

CONTAMINATED SOILS  
 & ALL DRUMMED WASTES

**800-UST-SOIL**  
 NATIONWIDE  
 AARON ENVIRONMENTAL SERVICES CORP.

## Eichley Engineers Inc.

Environmental Services Group

Air Emissions Control	Solid Waste Management
Environmental Audits	Site Assessments
Facility Planning	Storm Water Management
Waste Minimization	Pollution Prevention
Wastewater Treatment	Permitting
Feasibility Studies	Remediation Services
Detailed Design	Tank Management

6585 Penn Avenue  
 Pittsburgh, Pennsylvania 15206-4407  
**412-365-3454**  
**Serving Industry Nationwide**

## NEW ENVIRONMENT, INC.

40-HOUR  
**HAZWOPER**  
 TRAINING

**\$350**

NEW REDUCED PRICE  
 CELEBRATING OUR 5TH ANNIVERSARY

**800-732-3073**  
 Call for Information

## ZENON ENVIRONMENTAL LABORATORIES

"Quality Assured — Delivery Guaranteed"

- Full service environmental lab
- Expertise in soils, water and air toxics
- US Army Corps of Engineers accredited
- Sample pickup from Buffalo, NY

Burlington Ontario - (905) 332-8788  
 Burnaby, B.C. - (604) 444-4808  
 Anjou Quebec - (514) 493-4733

**FAX US YOUR AD:**  
**817-751-5171**

## WE WANT YOUR SLUDGE (WASTE) DISPOSAL BUSINESS!

✓ Are you looking for a "Better Price" and/or a "Better Place" to dispose of your wastestreams?

**WSI Has Immediate Sites For:**

- ♦ Treated Sewage Sludge (For Beneficial Use Only - land application & compost production) & All Other Sewage Sludges (Landfills)
- ♦ Class "I" & Class "II" - Non-Hazardous Liquid (Food & Non-Food) Waste (Injection Wells, re-processing, etc.)
- ♦ Class "A" - Low Level Radioactive Waste Solutions (New landfill, all the latest technology)
- ♦ Dioxin, PCB's & Medical Wastes (Thermal Destruction)

✓ We can offer you contracts at our Facilities in North America & Mexico for 1, 5, 10 years and more!

✓ Call and Let Us Know, What It's Going to Take, to Get Your Waste Disposal Business!

**Please Call: 800-377-1724**  
**Waste Solutions, Inc. (WSI)**

# PROFESSIONAL DIRECTORY

**Environmental Remediation Systems, Inc.**

**EPA  
OSHA  
HELP!**

\$995 retainer fee provides 24 hours per year of Confidential Consultation and Project Service.

ERS is a national environmental firm with 6 years of experience specializing in EPA and OSHA Regulatory Compliance. Consultation Staff includes:

Ph.D., Environmental Law  
J.D., Attorney at Law  
Environmental Engineer  
Chemist, OSHA Instructor

Call 800-452-6996 To Begin Today

**HDR Engineering, Inc.**

Wastewater/Storm Water/Water Reuse  
Industrial Wastewater and Air Quality  
NPDES Permits  
Environmental  
Solid Waste Management

Telephone: 402 399-1000

**!! SALVAGE CHEMICALS BOUGHT !!  
35th ANNIVERSARY**

Chemicals, Freons, Resins, Solvents, Plastics, Exotic Metals, Borates, Ions, Carbons, Genesolves, Oils, Dyes, Nylons, Spool Ends, Oxides. Also: Advanced Composites (Kevlar, Nextel, Fiberglass, Carbon Fibers, Yarns)

**KEMSTAR CORP.**

West: (310) 390-0180 East: (914) 681-0126  
FAX: (310) 391-8143 Fax: (310) 391-8143

**Express**  
A Division of Clean Air Engineering

Equipment Sales and Service

- Custom Design and Manufacturing
- Technical Assistance
- Express Overnight Delivery

**CEM Equipment**

- Sample Probes
- Heated Sample Lines
- Dilution CEM Probe
- Extractive CEM Flow Control Panel
- Sample Gas Conditioners

**800-223-3977**

**ENVIRONMENTAL EDUCATION ENTERPRISES**

**Presenting 60 Advanced Technical Short Courses Annually**

**HYDROGEOLOGY, MICROBIOLOGY, GEOCHEMISTRY, GEOPHYSICS, RISK, REMEDIATION, COMPUTER MODELING, MATHEMATICS, STATISTICS AND MORE.**

- Your Friend Attends Free
- Special Government/Student Rates
- 2 Scholarships per course
- Continuing Education Credits
- \$100.00 Future use Rebate

For additional information contact Dr. Jay Lehr  
1-800-792-0005 or 614-792-0005  
or FAX 614-792-0006  
E3, 2764 Sawbury Blvd., Columbus, OH 43235

**Raising Education to a Higher Power for the Environment**

**CONTAINER BAG LINERS**



Leak Protection for Roll-Offs  
Dump Trailers and Railroad Cars

**PACKAGING RESEARCH & DESIGN CORP.**  
P. O. Box 678, Madison, Mississippi 39130-0678  
TOLL FREE 1-800-833-9364

**Site History Information**

We research historic city directories and other sources, for prior use and occupancy information (50 to 90 years), on sites throughout the United States. Please call for further information. M.L. River Group 1-800-200-0422.

**Laboratory Services**

Certified NPDES Testing  
Bioassay • Biomonitoring  
Analytical Chemistry

**800-522-6397**

**United States Testing Co., Inc.**

**FAX US YOUR AD**

**817-751-5171**

**SECONDARY CONTAINMENT  
SPILL KING**

FEATURES:

- Removable deck (by forklift) for easy access and cleaning.
- Chemical & corrosion resistant
- Recessed rings on deck pallet for secure drum storage
- One-piece molded sump construction
- Four-way entry for forklift
- Free Weather Shield provided with each unit



**SAFE ENVIRONMENTAL STORAGE CORP.**  
180 Devon Ave. • P.O. Box 36 • Bensenville, IL 60106  
PHONE (800) 593-SAFE (708) 595-0666

**ENVIRONMENTAL & SAFETY SERVICES, INC.**

**ENVIRONMENTAL HEALTH & SAFETY MANAGER CERTIFICATE COURSE**  
Independent Study Format

COURSE PACKAGE INCLUDES:

- Hazwoper • Hazcom • Confined-Space Entry
- Lockout/Tagout • Bloodborne Pathogens
- DOT HM128F • RCRA • CERCLA/SARA
- CWA • CAA • Contingency Plans • SPCC Plans • Emergency Action Plans • Site Safety & Health Plans • Emergency Response Plans
- Fire Prevention & Control Plans • Medical Surveillance • Environmental & Safety Assessments/Audits

Approved by the Institute of Hazardous Material Management for Certified Hazardous Material Manager (CHMM) and by the National Registry of Environmental Professionals for Registered Environmental Manager (REM)

PRICE \$595.00 (all materials included)  
CALL or WRITE FOR DETAILS (910)-763-6999  
Box 3394 Wilmington, NC 28406

**Environmental Certification Program**

A Business Degree is not enough to handle the task as an Environmental Mgr. But with our program you'll be ready for everything... even the EPA.

Learn in detail about:

- Environmental Laws
- Waste Reduction & Minimization
- Risk Assessment
- Toxic Substance
- Hazardous Waste

FREE Catalog  
**(800) 474-1705**

Envionwaste Management Program

**THE MTEE ADVANTAGE  
EQUIPMENT SPECIALISTS**

> REPAIRS

..... MANOMETERS  
. NEG. AIR MACHINES

> MANUFACTURING

..MICRO-MONITOR II  
FIREBREAKER SYSTEM

1300 W. STEEL ROAD - UNIT #2  
MORRISVILLE, PA. 19067  
(215) 295-8208 fax (215) 295-8761

Fax your ad — (817) 751-5171

# PROFESSIONAL DIRECTORY

## WINDSOCK/FRAME

Used by  
\*Environmental/Medical Facilities  
\*Highway Depts. \*Airports



Unique design with internal windsock support gives maximum accuracy. Bright orange nylon windsock with free-swiveling frame. Low Maintenance.

Long Life. Cat. No. M-083-400

13" Dia. Windsock and frame  
Only \$61.50

-Quantity pricing available-

-Additional sizes available-

Call Toll-Free 1-800-558-6868

Wag-Aero Group

Dept. 39394 Lyons, WI 53148

## HAZARDOUS WASTE DRUMS SPECIALIZING IN OVERPAKS

D.O.T. APPROVED DRUMS

New and Reconditioned

Steel • Plastic • Fiber • 5 to 110 Gallons

NO ORDER IS TOO SMALL

One Drum to Truck Loads Shipped

Anywhere Prices Depend on Quantity

If we do not stock a special drum,

we will get it for you.

JAMES T. WARRING SONS, INC.

4545 "S" Street, Capital Heights, MD

20743

(301) 322-5400 — (301) 925-8874 FAX

## IATL

International Asbestos Testing Laboratories

### ASBESTOS ANALYTICAL SERVICES

- Complete In-House Facilities
- PCM, PLM and TEM
- Air, Bulk, Dust and Water Samples
- NVLAP and NY-ELAP Accredited

### LEAD ANALYTICAL SERVICES

- Air, Paint, Soil, Dust and Water
- Flame and Graphite Furnace AAS
- AIHA - ELPAT Participants

IATL is an AIHA Accredited Industrial Hygiene Laboratory

CALL FOR PRICE QUOTES AND INFORMATION

(609) 231-9449

16000 Horizon Way, Unit 100  
Mt. Laurel, NJ 08054

## Portable Sludge Dewatering

- Pressure Filtration Unit • Belt Filter Press
- Centrifuge • Sludge Dryer
- Liquid Solid Concentrator • Dredging

J.D. Meagher, Inc.

P.O. Box 752 ■ Westboro, MA 10581 ■ 508 366-6606

## Safe-T-Tank

ABOVE GROUND DOUBLE CONTAINMENT

1-800-536-8910

## YSC York Services Corporation

Over 25 Years of Air Quality Services

- Source Testing — EPA Methods
- CEM Certification/Audits
- Ambient Air Monitoring
- Dispersion Modeling/Meteorology
- Total In-House Laboratory Capabilities

One Research Drive

Stamford, CT 06906

(203) 325-1371 FAX: (203) 357-0166



## Scott Specialty Gases, Inc.

The World Supplier of Gaseous Standards

- Interference-Free™ EPA Protocol Gases
- Acublend® Calibration Gases
- Micrograv™ ppt Gas Mixtures
- Ultra Zero Pure Gases
- Gas Delivery Systems and Handling Equipment
- Technical Assistance

6141 Easton Road, Plumsteadville, PA 18949

(800) 331-4953

SPECIALISTS IN:

## INDOOR AIR QUALITY

- Testing for Building Related Disease
- Inspection and Testing of HVAC Systems
- Employee Complaints
- Testing for Chemicals, Molds, Bacteria, Asbestos
- Rapid Response-Nationwide

ATLANTIC ENVIRONMENTAL INC.

2 E. BLACKWELL ST. DOVER, NJ 07801

201-366-4660

REGIONAL OFFICES: ATLANTA • CHICAGO

1-800-344-4414

## TCLP

### Agitators to ZHES

We Meet Your Equipment Needs  
Associated Design & Manufacturing

SAMPLING DEVICES

CUSTOM MFG. AVAILABLE

Alexandria, VA 22314

1-800-837-TCLP

## Are You Dealing with an Independent Lab?

You should be!

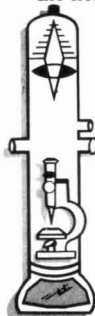

- Offering Analytical Services Nationwide
- No Conflict of Interest
- Fast, Dependable, Quality Service
- Competitive Prices
- No Hidden Costs
- Samples Archived

• NVLAP Accredited - Laboratory #1151

- TEM Air Bulk & Water
- RM-PCM-SEM
- AIHA - Lab #5206-001
- New York ELAP - Lab #C099
- SAME-DAY Results Available
- CEM Services Available
- Engineering and Consulting Services Available
- Materials Characterization by SEM

One of the Oldest, Most Reliable and Experienced Asbestos Laboratories in the United States



MICRO ANALYTICAL  
LABORATORIES, INC.  
Independent Asbestos Services Nationwide

3618 N.W. 97TH BLVD., GAINESVILLE, FL 32606  
(904) 332-1701 • (800) 358-3160 • FAX (904) 332-3572

## OFF CAMPUS

BS • MS • PHD

Environmental Engineering  
Occupational Safety & Health  
Health Sciences

## CERTIFICATIONS

CECM

Certified Environmental Compliance Manager

CECD

Certified Ergonomic Compliance Director



The University of  
Environmental Sciences

800-977-8449

The companies listed here  
are waiting to help you with  
your company's needs

Look for your 1995 Media Kit!

# PROFESSIONAL DIRECTORY

## INSURANCE AND BONDS

WEAKLEY  
and  
COMPANY



1-800-288-6099

P.O. Box 516065  
Dallas, Texas 75251

## New Patent Pending HAZARDOUS GAS SCRUBBER PROCESS

Scrub and destroy halogenated organic compounds i.e., vcm, chloroform, tri chlor, & per chlor ethylene, E.D.C., etc. from vent streams at ambient temperatures.

Demo system available  
for on-site trial.  
Call for a free video



**QUANTUM**  
TECHNOLOGIES, INC.

1632 Enterprise Pkwy., Unit F  
Twinsburg, Ohio 44087

800-248-4349

Fax: 216-425-0955

*Tell our advertisers  
you saw their ad in  
Environmental Protection!*

## NEED DRUMS TOMORROW? CALL TOLL-FREE TODAY! 1-800-366-7044

- STAINLESS STEEL DRUMS
- STEEL DRUMS
- POLYETHYLENE DRUMS
- SALVAGE & OVERPACK DRUMS
- PAILS AND CANS
- FIBER DRUMS
- HAZARDOUS WASTE DRUMS
- DRUM ACCESSORIES

**GENERAL  
CONTAINER  
CORP.**

620 Ramsey Ave. • P.O. Box 686  
Hillside, New Jersey 07205  
TEL: 908/687-8233 • FAX: 908/687-5437  
OUR REPUTATION IS STAINLESS.

## FILTER PRESSES

HIGHEST QUALITY  
PRICED RIGHT!

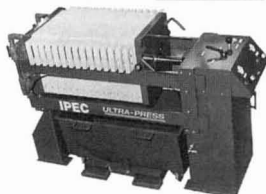

**IPEC**

TEL. (909) 270-0333  
FAX. (909) 270-0336

## GERAGHTY & MILLER, INC. Environmental Services Integrated Environmental Solutions



INVESTIGATION  
ENGINEERING  
CONSTRUCTION

Call (303) 294-1200

A HEIDEMIJ COMPANY

## QUALITY SAFETY SERVICES, INC.

### SAFETY TRAINING COURSES

Approved OSHA 1910 & 1926

40 & 24 Hour HAZWOPER

First Responder Training

DOT Hazardous Materials

Hazard Communication

Bloodborne Pathogens

Safety Management

and many others

San Antonio, Texas

(210) 633-0106 (800) 259-0016

## U.S. ENVIRONMENTAL ENGINEERING, INC.

### Custom Engineered Industrial Wastewater Treatment Systems

- Full Service: Treatability, Design, Permitting, Fabrication, Installation, & Training
- Redesign of Existing Systems
- Hundreds of Unit Processes in Unlimited Treatment Train Combinations
- Systems Installed Nationwide



CALL OR WRITE US FOR ADDITIONAL INFORMATION

1-(800) 989-0200

1100 Northmeadow Pkwy. • Suite 108 • Roswell, GA 30076

THE LEADING PROVIDER OF  
COMPLETE, INTEGRATED  
ENVIRONMENTAL SERVICES  
IN NORTH AMERICA

**Clayton**  
ENVIRONMENTAL  
CONSULTANTS

- ▼ Environmental Management
- ▼ Environmental Health
- ▼ Analytical Laboratory
- ▼ Risk Assessments
- ▼ Litigation Support

For more information, please call your nearest Clayton office.

Detroit 810-344-1770	New York 908-225-6040	Atlanta 404-499-7500	San Francisco 510-426-2600
Los Angeles 714-229-4806	Honolulu 808-531-6708	Minneapolis 612-854-0112	Cleveland 216-686-5100

## MILLIPORE

Immunoassay Field Tests

- Pesticides
- PCB, BTEX, TNT...MORE!

Widest selection  
more than 50 kits

Call Toll-Free  
1-800-MILLIPORE

If you would like to order reprints of any article in Environmental Protection magazine, please contact Cherie Chastain Production Manager (817) 776-9000.

# PROFESSIONAL DIRECTORY



## CRAM-A-LOT® SOLID WASTE AND RECYCLING EQUIPMENT

"helping manage America's trash"

- Horizontal and Vertical Balers
- Stationary and Self-Contained Compactors
- Receivers and Recycling Containers
- Transfer Stations

Built By The Company  
Dedicated To  
Quality Equipment  
Responsive Service  
Customer Satisfaction

### J.V. MANUFACTURING, INC.

501-751-7320 • Fax: 501-751-7774  
Hwy. 265-S • P.O. Box 229  
Springdale, AR 72765  
Marketing and servicing the United States,  
Canada, Mexico and Puerto Rico.

## SOLID WASTE HANDLING EQUIPMENT



- Knuckle boom loaders
- Specialized attachments

For details:

USA : ROTOBEC USA INC.  
Tel: (603) 444-2103

ROTOBEC-WEST USA INC.  
Tel: (206) 357-6480

CANADA : ROTOBEC INC.-HEAD OFFICE  
Tel: (418) 383-3002



ROTOBEC CANADA WEST INC.  
Tel: (204) 326-1403

rotobec

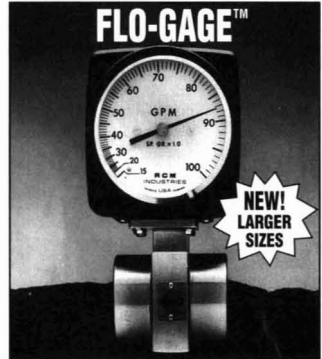

Direct Reading, Differential Pressure Flowmeter  
for Liquids, Gases and Compressed Air

- Calibrated for your temperature, pressure & viscosity
- Accuracy ±3% FS
- Rugged Industrial Construction
- Large 3.5" dial (270°)
- Transmitter and Limit Switch Options
- Reed Switches

**1-800-NOW-FLOW**

**-RCM Industries, Inc.**

P.O. Box 6554 Concord, CA 94524-6554  
Tel. (510)687-8363 Fax (510)671-9636



## Our Sludge Judge® Can Help You Judge

Sampling suspended solids is easy with NASCO's Sludge Judge®. Made of 1/4" clear noncorrosive plastic, it is ideal for sewage treatment, chemical plants, and other facilities where accurate samples of noncaustic materials are required. Comes in five foot sections (2 1/2 ft. top section also available), and the one foot markers give a quick indication of sample depth. For more information and a FREE Sampling Products Catalog, write Dept. WP501, or call our toll free number.

Free Phone Order Service:  
1-800-558-9595

FAX: 1-414-563-8296

*Nasco*

P.O. Box 901, Fort Atkinson, WI 53538-0901  
P.O. Box 3837, Modesto, CA 95352-3837  
NASCO PLASTICS, Ontario, Canada  
Phone: 519-662-2540

## THE GENERAL CARBON CORP.

ACTIVATED CARBON SINCE 1957

- Complete line of Carbons for Water and Air Purification made from Coal, Coconut Shell or Wood.
- Immediate Shipment from our Fully Stocked Warehouse.
- Low Cost 55 Gallon Purification Barrels.
- Vapor and Liquid Phase Vessels and Systems.
- Complete Carbon Change-out and Regeneration Service.
- Full Stack of Impregnated Carbons.
- Custom Made Carbon Panels.
- Complete Carbon Packaging Facilities on Site.

## ACTIVATED CARBON EQUIPMENT & CHANGEOUT SERVICES

33 Paterson Street  
Paterson, New Jersey 07501  
Phone: (201) 523-2223  
Fax: (201) 523-1494

## BALDWIN ENVIRONMENTAL ELECTRONIC WATER CONDENSERS

1. PROVEN TO HAVE BEST PERFORMANCE
2. SEALED HINGED DOORS
3. FIELD FRIENDLY
4. RELIABLE
5. THEY JUST PLAIN LOOK GOOD!!!



WHEN USED AS A SAMPLE  
CONDITIONING SYSTEM  
THEY ARE ALL OF THE  
ABOVE AND MORE!  
CALL FOR MORE INFORMATION:

**BALDWIN  
ENVIRONMENTAL INC.**  
5401 LONGLEY LANE #42  
RENO, NEVADA 89511 USA  
(702) 828-1300 (702) 828-1305

*Classified ads serve as a reference tool for your potential clients. Call to reserve your ad space today our representatives are waiting to hear from you.*

# AD INDEX

Circle #	Advertiser	Page #			
95	ABB Air Preheater Inc.	141	33	Hemco	31
92	Achieve! Technology Inc.	139	62	Hi-Q Environmental Products Co.	47
48	AdWest Technologies Inc.	36	58	Horiba Instruments Inc.	44
42	Aero Tec Laboratories Inc.	34	24	Hydrolab Corporation	22
37	American Safety Risk Retention Group Inc.	32	27	Information Handling Systems	25
101	Applied Automation	164	57	Jardine Environmental Services	44
68	Art's Manufacturing & Supply	53	14	Lancaster Laboratories	7
67	Auburn International	53	44	Liquid Waste Technology	35
12	Badger Meter Inc.	4	91	Logical Technology Inc.	138
79	Carylon Companies	66	73	Longyear	61
81	CAS	100,101	28	Met One Instruments	26
-	Century West	10a-b	55	Met Pro Corporation	43
29	Clamshell Buildings Inc.	27	76	Milco Safety Rental	64
43	Clements Associates Inc.	34	20	Milltronics	16
36	Colog Inc.	32	25	MMC International Corporation	23
77	Commercial Dexterity Ltd.	64	59	Mobile Process Technology	48
88	Computer Alli.	42	45	Mount Sopris	35
93	ConVault	140	21	National Technical Systems	17
19	Counterpoint Publishing	14	90	New Pig Corporation	138
64	CPI Electronic Publishing	48	-	New York State Dept of Economics	10a-b
39	Davis Instruments	33	65	Niro Inc.	51
103	Delta Cooling Towers	62	1	Omega Engineering Inc.	2
100	Desalination Systems Inc.	163	34	Osmonics Co.	31
75	Dieterich Standard	64	41	Pallflex	34
31	Diversified Well Products Inc.	30	98	Parker Hannifin Corporation	144
32	Dynecol	30	54	Photovac Monitoring Instruments	42
70	Eco Waste Solutions	55	74	The Powder Coating Institute	63
97	ECS	143	63	RM Young	47
66	Ejector Systems	52	5	Safety Storage	70
-	EM Science	18a-d	6	Safety Storage	70
17	Energy Efficiency Systems	11	7	Safety Storage	70
22	Environmental Restoration Systems Inc.	18	8	Safety Storage	70
104	Environmental Systems Engineering	62	87	Salem Engelhard	119
26	Epoleon Corporation	24	84	Schonstedt Instruments Co.	109
35	Fabric Building Systems Inc.	32	85	Schonstedt Instruments Co.	109
78	Foxboro	46	49	Shred Tech	38
69	Geo-Con Inc.	54	52	Solinst Canada Ltd.	39
53	Goodway USA	41	71	Stevens Compliance Library	56,57
40	Groundwater & Environmental Services Inc.	33	18	The Stevens Environmental Sourcebook Directory	12
94	Hazen Research Inc.	140	72	Stevens Publishing Corp Book Div	58,59
61	Hazmacon '95	49	46	Terra Consulting Group	35
51	Haz-Mat Containment Corporation Inc.	39	47	Terra Consulting Group	36
56	Haz-Safe	43	11	Tri-Rinse	3
96	Heath Consultants	142	60	Tymco	65
			16	Unipure Environmental	10
			102	Vertek	61
			30	Wallace & Tierman	29
			86	Water Pollution Control News	112,113
			23	Wheelabrator	19
			3	Wheelabrator Clean Air	136
			38	White Horse	33
			15	Williams Knowledge Systems Inc.	9
			50	Zero Enclosures	38
			82	Zurich-American Insurance Group	104,105
				<b>NEW PRODUCTS</b>	
			121	Barnaby & Stuccliffe	147
			122	Carbtrol	147
			112	CID Associates	146
			116	Columbus Instruments	146
			128	Controlotron	147
			120	Dohrmann	147
			132	EIT	148
			135	Environmental Instruments	148
			127	Gelok	147
			110	Hersey Measurement Co.	146
			125	Inter-Apparel	147
			124	Kinetico	147
			138	K-Tron Soder	149
			139	Lancaster Laboratories	149
			131	Met One Instruments	148
			111	Metrotech	146
			134	Microbics	148
			123	Milltronics	147
			113	Omega	146
			118	Omega	146
			114	Pace Inc.	146
			133	Paco Pumps	148
			136	Safe Environmental Storage Corp.	148
			115	Safety Storage	146
			137	Sierra Monitor	149
			119	SouthStar Systems	146
			129	Sybron	148
			117	Waid & Associates	146
			130	Wey Valve	148
			126	Xomox	147
				<b>PRODUCT LITERATURE</b>	
			145	Airborne Environmental Survey	137
			149	Cole-Parmer Instrument Co.	137
			148	Environmental Fuel Systems Inc.	137
			146	GasTech	137
			150	Morehouse-COWLES	137
			147	National Instruments	137
			151	SIMCO	137



NO POSTAGE  
NECESSARY  
IF MAILED  
IN THE  
UNITED STATES



**BUSINESS REPLY MAIL**  
FIRST CLASS PERMIT NO. 1791 WACO, TX

POSTAGE WILL BE PAID BY ADDRESSEE

Stevens Publishing  
**Environmental  
PROTECTION**  
Reader Service  
Management Department  
P.O. Box 2573  
Waco, TX 76702-9910



# Environmental PROTECTION

January 1995  
Card Expires March 1995  
**Reader Service Card**

For FREE information on products advertised in this issue, circle their Reader Service Number on the card below. Please type or print clearly and answer all the questions on the card.

352950150

**PLEASE SEND ME FREE INFORMATION ON THE FOLLOWING ITEMS:**

1	2	3	4	5	6	7	8	9	10	11	12	13	14	15	16	17	18	19	20
21	22	23	24	25	26	27	28	29	30	31	32	33	34	35	36	37	38	39	40
41	42	43	44	45	46	47	48	49	50	51	52	53	54	55	56	57	58	59	60
61	62	63	64	65	66	67	68	69	70	71	72	73	74	75	76	77	78	79	80
81	82	83	84	85	86	87	88	89	90	91	92	93	94	95	96	97	98	99	100
101	102	103	104	105	106	107	108	109	110	111	112	113	114	115	116	117	118	119	120
121	122	123	124	125	126	127	128	129	130	131	132	133	134	135	136	137	138	139	140
141	142	143	144	145	146	147	148	149	150	151	152	153	154	155	156	157	158	159	160
161	162	163	164	165	166	167	168	169	170	171	172	173	174	175	176	177	178	179	180
181	182	183	184	185	186	187	188	189	190	191	192	193	194	195	196	197	198	199	200

**For faster service—photocopy this side only and send to our FAX # (817) 662-7075**

PLEASE PRINT OR AFFIX LABEL HERE

NAME \_\_\_\_\_

COMPANY \_\_\_\_\_

ADDRESS \_\_\_\_\_  Home  Bus.

CITY \_\_\_\_\_ STATE \_\_\_\_\_ ZIP \_\_\_\_\_

- YES**, I would like to receive/continue to receive **Environmental Protection**.
- NO**, I'm not interested at this time.

Signature \_\_\_\_\_ **Signature Required For FREE Subscription** Date \_\_\_\_\_

Title \_\_\_\_\_

Business Phone ( \_\_\_\_\_ ) \_\_\_\_\_ FAX No. ( \_\_\_\_\_ ) \_\_\_\_\_

Home Phone ( \_\_\_\_\_ ) \_\_\_\_\_

- Function which best describes your activity in Pollution Control (check only one):
  - A  Corporate responsibility for Pollution Control
  - B  Manage all Pollution Control Operations at this location
  - C  Supervise sub-group in Pollution Control Operations
  - D  Provide professional consulting service on Pollution Control
  - E  Provide staff environmental service on Pollution Control
  - Z  Other (please specify) \_\_\_\_\_
- Type of Business (check only one):
  - A  **Manufacturing. If manufacturing, please check the appropriate SIC (check only one):**
    - (20) Food
    - (21) Tobacco
    - (22) Textile
    - (23) Apparel
    - (24) Lumber & Wood
    - (25) Furniture
    - (26) Paper
    - (27) Print/Publish
    - (28) Chemicals
    - (29) Petrol. & Coal
    - (30) Rubber/Plastic
    - (31) Leather
    - (32) Stone/Clay/Glass
    - (33) Primary Metal
    - (34) Fab. Metal
    - (35) Mach., except Elect.
    - (36) Elect. & Electron. Mach.
    - (37) Trans. Equip.
    - (38) Instru/meas/analyz/controlling
    - (39) Miscellaneous Mfg.
  - B  Mining
  - C  Agriculture
  - D  Engineering & Contracting
  - L  Consulting
  - M  Insurance
  - E  Utilities, public, private & cooperative
  - F  Govt. including municipal or district sanitary water or wastewater trmnt. sys. or plants
- Type of Govt:
  - G  City
  - H  County
  - I  State
  - J  Federal
  - K  Transportation
  - N  Labs
  - O  Training
  - P  Real Estate
  - Z  Misc. Services \_\_\_\_\_ (please specify)
3. Approximate number of employees at this address (check only one):
  - A  1-19
  - B  20-49
  - C  50-99
  - D  100-249
  - E  250-499
  - F  500-999
  - G  1000-1499
  - H  1500-2499
  - I  2500 and up
4. In your job function do you recommend, specify or purchase? (check all that apply):
  - A  Pollution Control Equipment
  - B  Instrumentation
  - C  Chemicals
  - D  Parts & equipment for maintenance operation and control
  - E  Services/Consulting
  - F  None of the above \_\_\_\_\_ (please specify)
5. What types of Pollution Control are you responsible for? (check all that apply):
  - A  Air
  - B  Water
  - C  Noise
  - D  Solid waste disposal
  - E  Industrial hygiene
  - F  Toxic & hazardous material
  - G  Energy control/energy conservation
  - H  None of the above \_\_\_\_\_ (please specify)
6. Which of the following publications do you receive personally addressed to you? (check all that apply):
  - A  Pollution Engineering
  - B  Environment Today
  - C  Hazmat World
  - D  Pollution Equipment News
  - E  The National Environmental Journal
  - F  Water Environment & Technology
  - G  None of the above \_\_\_\_\_ (please specify)



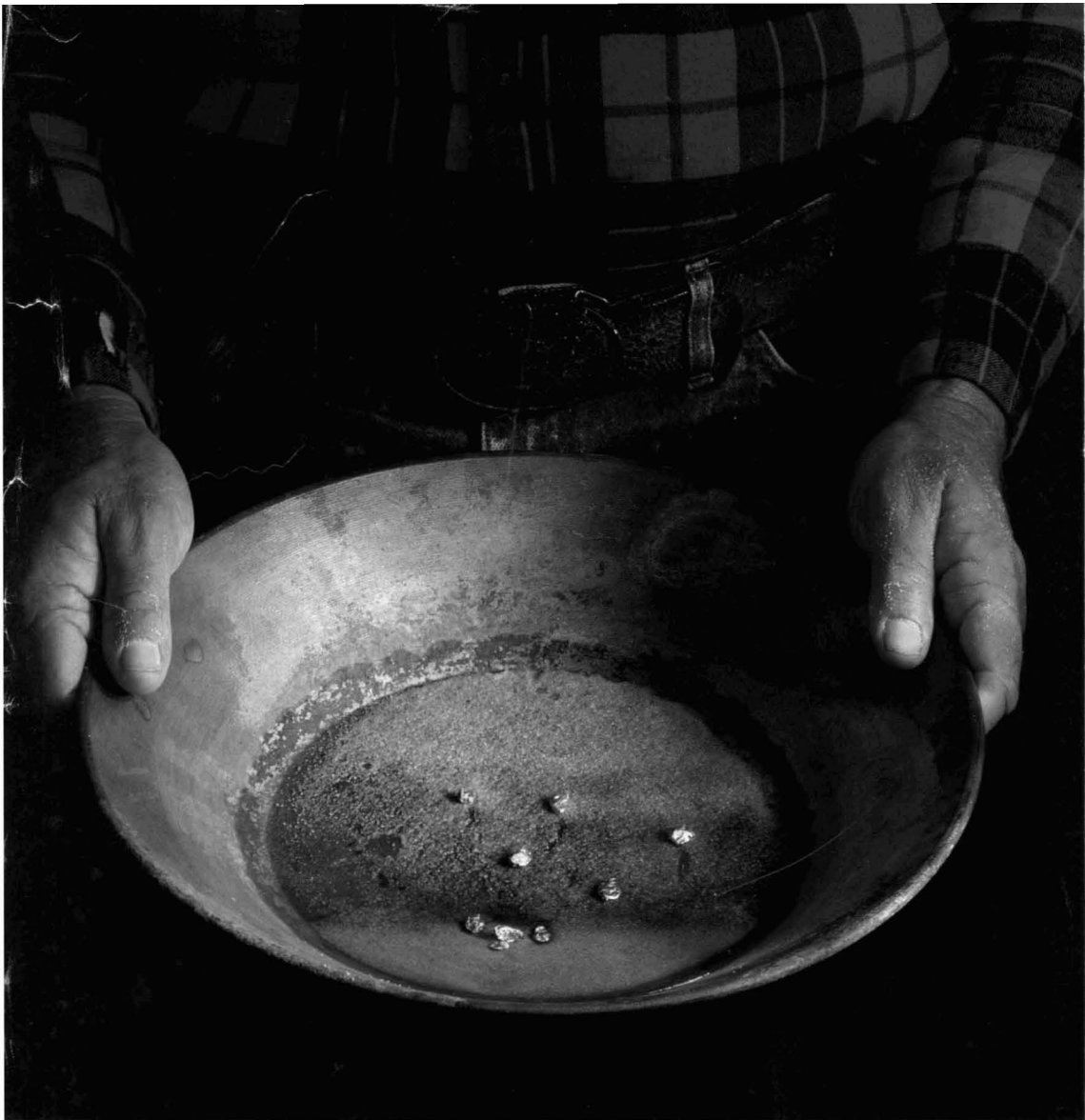

## Turn wastewater into a natural resource.

Desal spiral-wound elements make it possible to separate metals and minerals from a process stream as well as recirculate the water in industrial processes.

This enables you to reclaim nickel, copper, zinc and other valuable metals for reuse and satisfy govern-

ment regulations on pollution at the same time.

For more information call Desalination Systems, Inc. at (619) 746-4995 or fax your inquiries to (619) 747-8253. Let us be your natural resource for wastewater technology.

**DESAL**

MEMBRANE PRODUCTS

Circle 100 on card.



## When it comes to gas or liquid composition, our reputation for analysis is on the line

On-line analysis of process gas or liquid composition demands innovative analytical techniques, robust sampling systems, and durable instrument packaging. For decades, Applied Automation/Hartmann & Braun have provided thousands of process analytical measurement solutions to the hydrocarbon processing industry.

**We have the products and systems**—including process gas chromatograph, process FTIR, process infrared, ultraviolet, thermal conductivity, and paramagnetic oxygen analyzers, sample conditioning systems and shelters.

**We have the know-how**—to provide complete engineering for applications in product purity, fractionation control and emissions monitoring. Our solutions include motor fuels characterization, boiling point analysis, sulfurs in fuel gases, and oxygen measurement, to name but a few.

For more information, contact:

Applied Automation/ Hartmann & Braun  
P.O. Box 9999 Bartlesville, OK 74005  
Phone: (918) 662-7000  
FAX: (918) 662-7358